

STEERING SYSTEM (POWER STEERING)

PERIODIC MAINTENANCE SERVICES

25. Steering System (Power Steering)

A: INSPECTION

1. STEERING WHEEL

1) Set steering wheel in a straight-ahead position, and check wheel spokes to make sure they are correctly set in their specified positions.

2) Lightly turn steering wheel to the left and right to determine the point where front wheels start to move.

Measure the distance of the movement of steering wheel at the outer periphery of wheel.

Steering wheel free play:

0 — 17 mm (0 — 0.67 in)

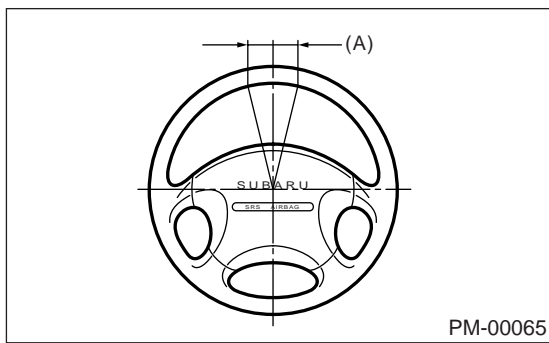

(A) Free play

Move steering wheel vertically toward the shaft to ascertain if there is play in the direction.

Maximum permissible play:

0.5 mm (0.020 in)

3) Drive vehicle and check the following items during operation.

(1) Steering force

The effort required for steering should be smooth and even at all points, and should not vary.

(2) Pull to one side

Steering wheel should not be pulled to either side while driving on a level surface.

(3) Wheel runout

Steering wheel should not show any sign of runout.

(4) Return factor

Steering wheel should return to its original position after it has been turned and then released.

2. STEERING SHAFT JOINT

1) When steering wheel free play is excessive, disconnect universal joint of steering shaft and check it for any play and yawing torque (at the point of the crossing direction). Also inspect for any damage to sealing or worn serrations. If the joint is loose, retighten the mounting bolts to the specified torque.

Tightening torque:

24 N·m (2.4 kgf·m, 17.4 ft·lb)

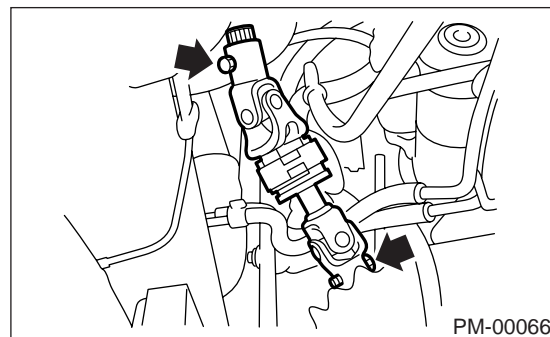

PM-00066

3. GEARBOX

1) With wheels placed on a level surface, turn steering wheel 90° in both the left and right directions.

While wheel is being rotated, reach under vehicle and check for looseness in gearbox.

Tightening torque:

59 N·m (6.0 kgf·m, 43.4 ft·lb)

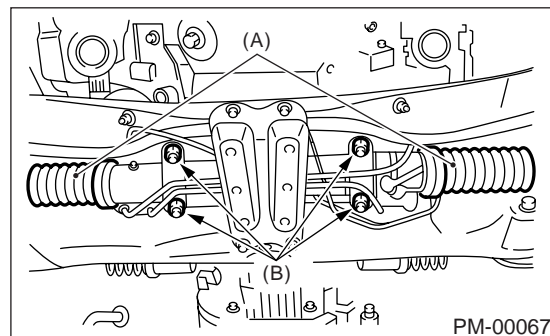

PM-00067

(A) Boot

(B) Gearbox mounting bolts

2) Check boot for damage, cracks or deterioration.
3) With vehicle on a level surface, quickly turn steering wheel to the left and right.

While steering wheel is being rotated, check the gear backlash. If any unusual noise is noticed, adjust the gear backlash in the following manner.

(1) Tighten adjusting screw to 7.4 N·m (0.75 kgf·m, 5.4 ft·lb) and then loosen. Repeat this operation twice.

(2) Retighten adjusting screw to 7.4 N·m (0.75 kgf·m, 5.4 ft·lb) and back off 25°.

STEERING SYSTEM (POWER STEERING)

PERIODIC MAINTENANCE SERVICES

- (3) Apply liquid packing to at least 1/3 of entire perimeter of adjusting screw thread.

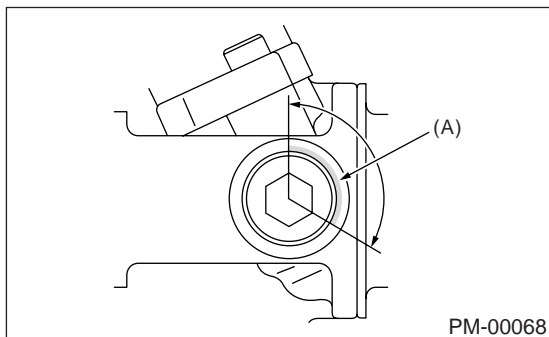

- (A) Apply liquid packing to at least 1/3 of entire perimeter.

- (4) Install lock nut. While holding adjusting screw with a wrench, tighten lock nut using ST 926230000 SPANNER

Tightening torque (Lock nut):
39 N·m (4.0 kgf-m, 29 ft-lb)

Hold the adjusting screw with a wrench to prevent it from turning while tightening the lock nut.

4. TIE-ROD

- 1) Check tie-rod and tie-rod ends for bends, scratches or other damage.

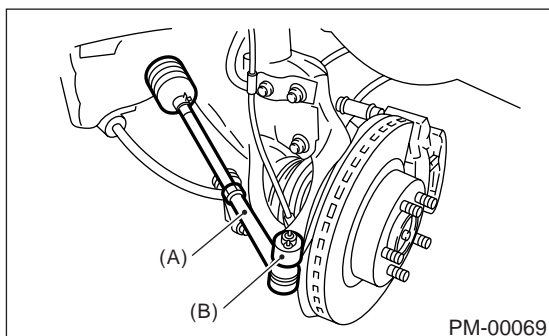

- (A) Tie-rod end
(B) Knuckle arm

- 2) Check connections of knuckle ball joints for play, inspect for damage on dust seals, and check free play of ball studs. If castle nut is loose, retighten it to the specified torque, then tighten further up to 60° until cotter pin hole is aligned.

Tightening torque:
27 N·m (2.75 kgf-m, 19.9 ft-lb)

- 3) Check lock nut on the tie-rod end for tightness. If it is loose, retighten it to the specified torque.

Tightening torque:
83 N·m (8.5 kgf-m, 61.5 ft-lb)

5. POWER STEERING FLUID LEVEL

NOTE:

The fluid level must be checked when the temperature of the reservoir tank surface is approximately 20°C (68°F).

- 1) Place vehicle with engine "off" on the flat and level surface.

- 2) Check the fluid level using the scale on the outside of the reservoir tank (A). If the level is below "MIN" (B), add fluid to bring it up to "MAX" (C).

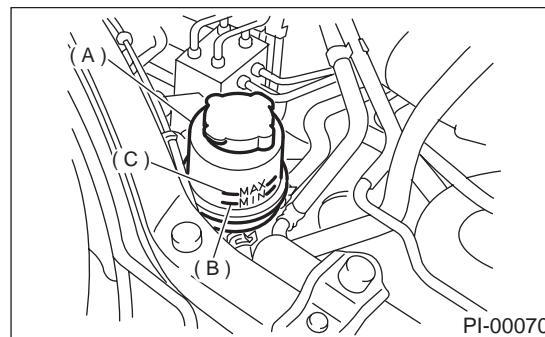

NOTE:

If fluid level is at MAX level or above, drain fluid to keep the level in the specified range of indicator by using a syringe or the like.

Recommended fluid:
Dexron III

Fluid capacity:
0.7 ℓ (0.7 US qt, 0.6 Imp qt)

6. POWER STEERING FLUID FOR LEAKS

Inspect the underside of oil pump and gearbox for power steering system, hoses, piping and their couplings for fluid leaks.

If fluid leaks are found, correct them by retightening their fitting bolts (or nuts) and/or replacing their parts.

NOTE:

- Wipe the leakage fluid off after correcting fluid leaks, or a wrong diagnosis is taken later.
- Also pay attention to clearances between hoses (or pipings) and other parts when inspecting fluid leaks.

STEERING SYSTEM (POWER STEERING)

PERIODIC MAINTENANCE SERVICES

7. HOSES OF OIL PUMP FOR DAMAGES

Check pressure hose and return hose of oil pump for crack, swell or damage. Replace hose with a new one if necessary.

NOTE:

Prevent hoses from revolving and/or turning when installing hoses.

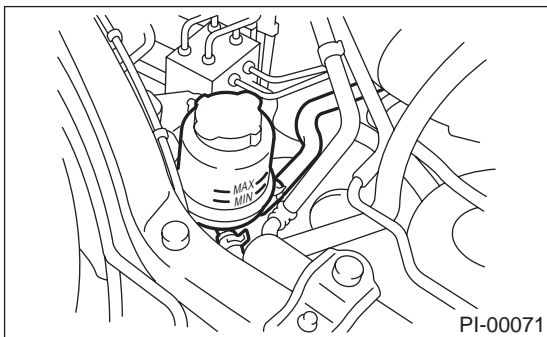

8. POWER STEERING PIPES FOR DAMAGE

Check power steering pipes for corrosion and damage.

Replace pipes with new ones if necessary.

9. GEARBOX BOOTS

Inspect both sides of gearbox boots as follows, and correct the defects if necessary.

- 1) (A) and (B) positions of gearbox boot are fitted correspondingly in (A) and (B) grooves of gearbox and the rod.
- 2) Clips are fitted outside of (A) and (B) positions of boot.
- 3) Boot does not have crack and hole.

NOTE:

Rotate (B) position of gearbox boot against twist of it produced by adjustment of toe-in, etc. Apply grease to the groove (C).

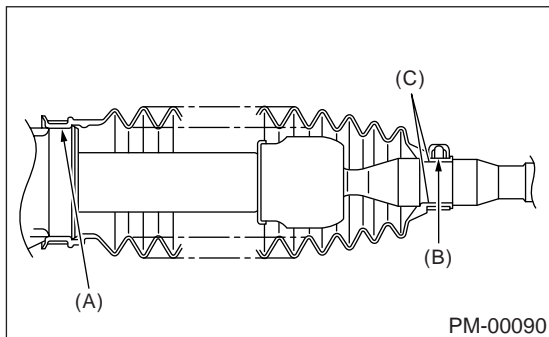

10. FITTING BOLTS AND NUTS

Inspect fitting bolts and nuts of oil pump and bracket for looseness, and retighten them if necessary. Inspect and/or retighten them when engine is cold.