

2-4 BRAKE

Automatic Transmission

4. 2-4 Brake

A: CONSTRUCTION

The 2-4 brake consists of a 2-4 brake piston, a return spring, a pressure plate, drive plates and driven plates.

This brake is engaged by the hydraulic pressure from the transmission control valve and locks the front sun gear when the 2nd gear is selected in the D, 3 or 2 range, or when the 4th gear is selected in the D range.

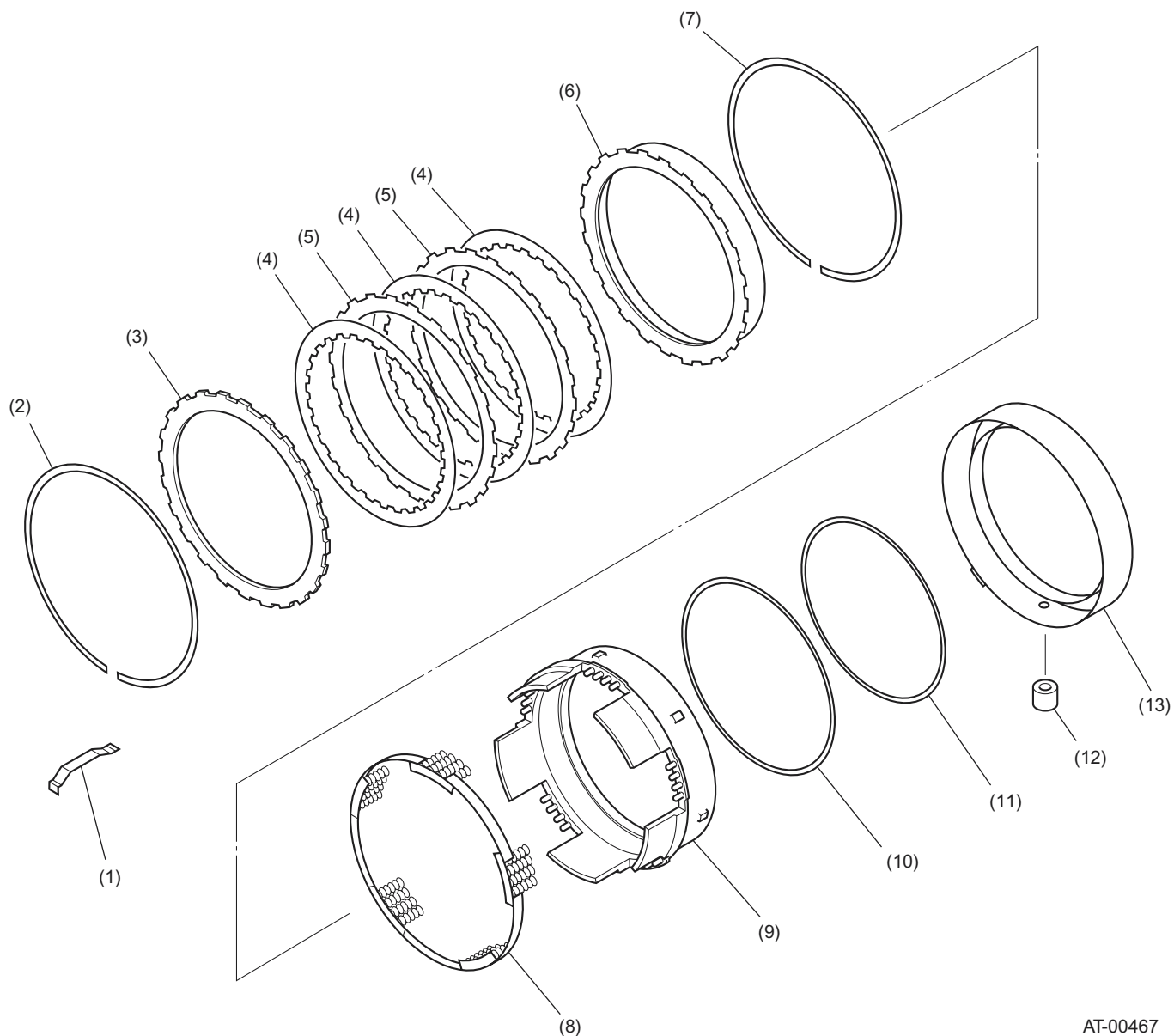

- (1) Leaf spring
- (2) Snap ring
- (3) Retaining plate
- (4) Drive plate
- (5) Driven plate

- (6) Pressure rear plate
- (7) Snap ring
- (8) Return spring
- (9) 2-4 brake piston

- (10) Lathe cut seal ring
- (11) Lathe cut seal ring
- (12) 2-4 brake piston seal
- (13) 2-4 brake piston retainer

AT-00467