

GEAR TRAIN

Automatic Transmission

9. Gear Train

A: CONSTRUCTION

The gear train consists of two sets of planetary gears, three sets of multi-plate clutches, two sets of multi-plate brakes and one set of one-way clutch.

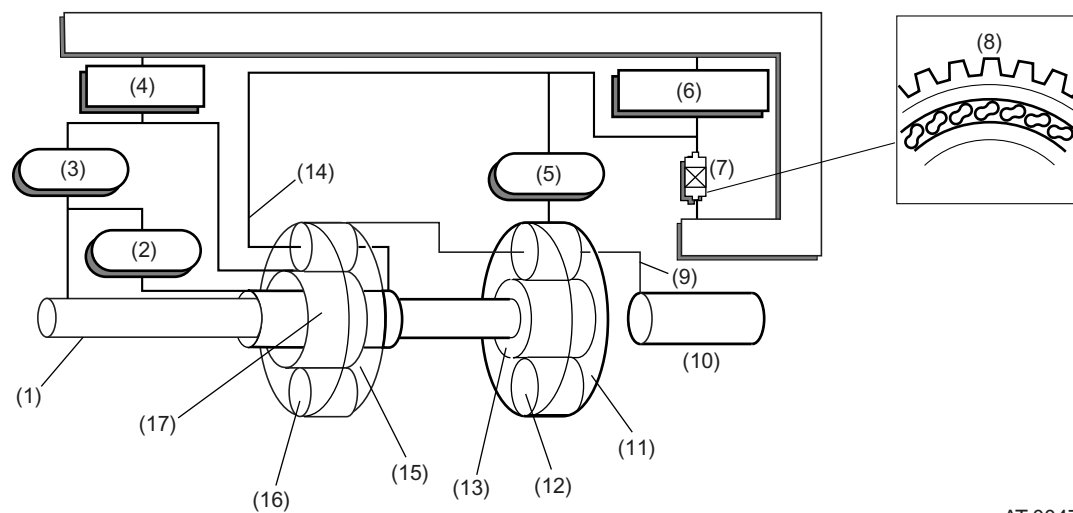

AT-00474

- | | | |
|---|--|------------------------------|
| (1) Input shaft | (7) One-way clutch | (13) Rear sun gear |
| (2) High clutch (Operates in 3rd and 4th speeds) | (8) Free/Locked | (14) Front planetary carrier |
| (3) Reverse clutch (Operates while moving in reverse) | (9) Rear planetary carrier | (15) Front internal gear |
| (4) 2-4 brake | (10) MPT models: Reduction drive shaft
VTD models: Intermediate shaft | (16) Front pinion gear |
| (5) Low clutch | (11) Rear internal gear | (17) Front sun gear |
| (6) Low & reverse brake | (12) Rear pinion gear | |

GEAR TRAIN

Automatic Transmission

B: OPERATION

1. OPERATION TABLE

		Reverse clutch	2-4 brake	High clutch	Low clutch	Low & reverse brake	One-way clutch	
Selector lever operation	P							
	R							
	N							
	D	1ST ↑↓						
		2ND ↑↓						
		3RD ↑↓						
		4TH ↑↓						
	3	1ST ↑↓						
		2ND ↑↓						
		3RD ↑↓						
		4TH ↑						
	2	1ST						
		2ND ↑						
		3RD ↑						
		4TH ↑						
	1	1ST ↑						
		2ND ↑						
		3RD ↑						
		4TH ↑						
	Sports shift	1ST ↑↓						
2ND ↑↓								
3RD ↑↓								
4TH ↑↓								

AT-00712

GEAR TRAIN

Automatic Transmission

2. N RANGE

Since the rear sun gear and the high clutch drum are in mesh with the input shaft, they rotate together with the input shaft.

The high clutch drum does not transmit the torque to the planetary unit since the reverse clutch and the high clutch are not engaged.

The torque of the rear sun gear is transmitted to the rear internal gear through the pinion gear.

However, the torque of the rear sun gear is not transmitted to the rear planetary carrier since the low clutch is disengaged and, therefore, the rear internal gear is freewheeling.

As a result, the torque of the input shaft is not transmitted to the reduction drive shaft.

Operating condition of components	Power flow (in acceleration)
All clutches and brakes : disengaged	<pre>graph TD; A[Input shaft] --> B[Rear sun gear]; B --> C[Rear pinion gear]; C --> D[Rear internal gear]; D --> E[Low clutch (free)];</pre> <p style="text-align: right;">AT-00476</p>

GEAR TRAIN

Automatic Transmission

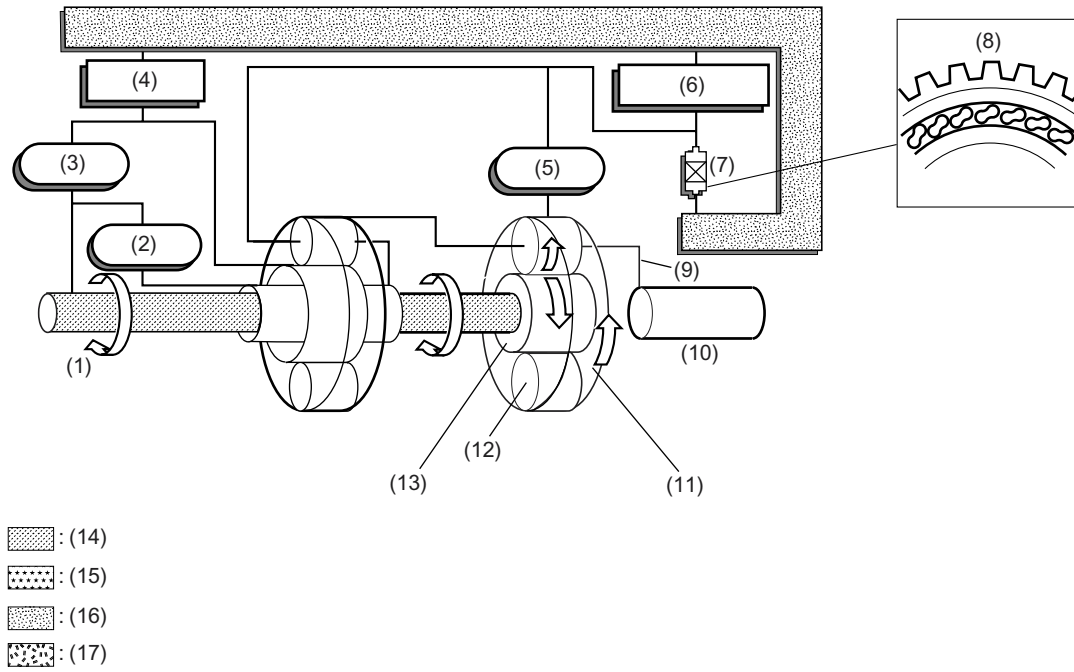

AT-00477

- | | | |
|-------------------------|--|--|
| (1) Input shaft | (7) One-way clutch | (13) Rear sun gear |
| (2) High clutch | (8) No effect | (14) Input |
| (3) Reverse clutch | (9) Rear planetary carrier | (15) Output |
| (4) 2-4 brake | (10) MPT models: Reduction drive shaft
VTD models: Intermediate shaft | (16) Locked |
| (5) Low clutch | (11) Rear internal gear | (17) Planetary gear components
involved in power transmission |
| (6) Low & reverse brake | (12) Rear pinion gear | |

GEAR TRAIN

Automatic Transmission

3. P RANGE

All the clutches and brakes are free, just as in the N range. The parking pawl engages with the parking gear which forms an integral part of the reduction drive gear, preventing the gear from rotating.

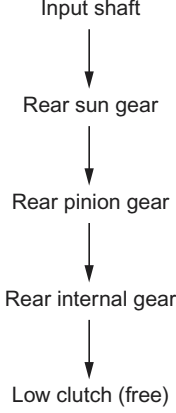
Operating condition of components	Power flow (in acceleration)
All clutches and brakes : disengaged	 <pre>graph TD; A[Input shaft] --> B[Rear sun gear]; B --> C[Rear pinion gear]; C --> D[Rear internal gear]; D --> E[Low clutch (free)];</pre> <p data-bbox="1251 1284 1348 1311">AT-00476</p>

GEAR TRAIN

Automatic Transmission

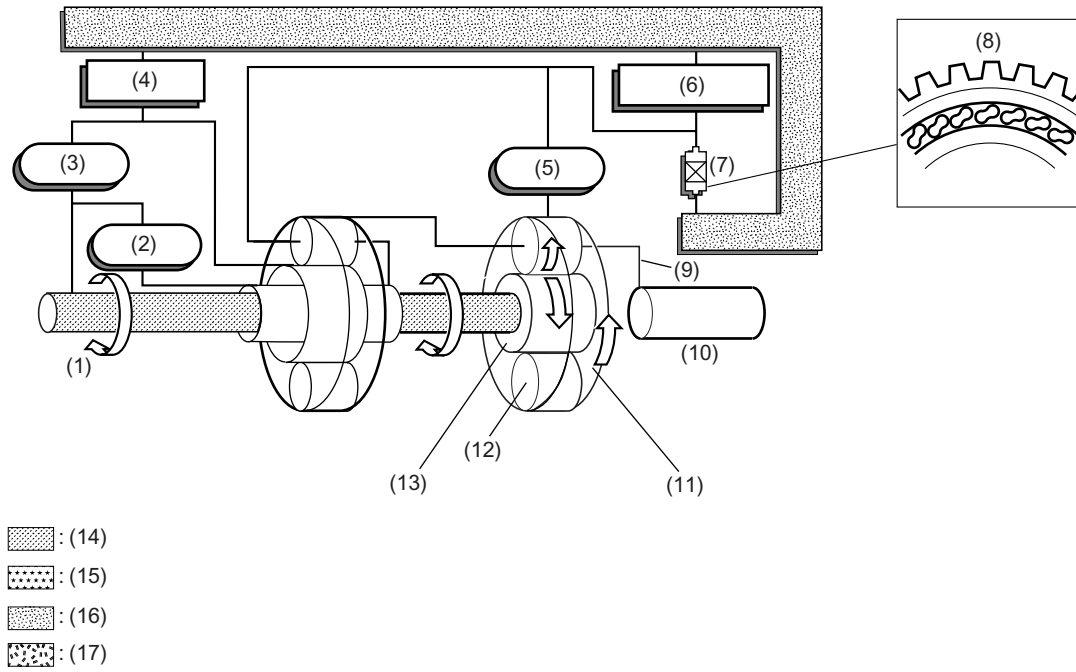

AT-00477

- | | | |
|-------------------------|--|--|
| (1) Input shaft | (7) One-way clutch | (13) Rear sun gear |
| (2) High clutch | (8) No effect | (14) Input |
| (3) Reverse clutch | (9) Rear planetary carrier | (15) Output |
| (4) 2-4 brake | (10) MPT models: Reduction drive shaft
VTD models: Intermediate shaft | (16) Locked |
| (5) Low clutch | (11) Rear internal gear | (17) Planetary gear components
involved in power transmission |
| (6) Low & reverse brake | (12) Rear pinion gear | |

GEAR TRAIN

Automatic Transmission

4. 1ST GEAR OF D OR 3 RANGE (D₁, 3₁)

When the 1st gear is selected in the D or 3 range, only the low clutch is engaged. In this state, the rear internal gear attempts to rotate counterclockwise but it is impossible by the action of the one-way clutch which locks the internal gear to the transmission case. As a result, rotation of the rear sun gear causes the pinion gears to rotate around the sun gear. This causes the planetary carrier to rotate. In this way, rotation of the input shaft is transmitted to the reduction drive shaft* after being subjected to speed reduction by the planetary gear train.

On the other hand, the rear internal gear rotates clockwise if the reverse driving force is applied to it by the reduction drive shaft* during coasting. This clockwise rotation of the internal gear causes the one-way clutch to freewheel. Since the power path between the reduction drive shaft* and the input shaft is lost as a result, no engine braking effect is available.

*: MPT models only. VTD models are equipped with an intermediate shaft.

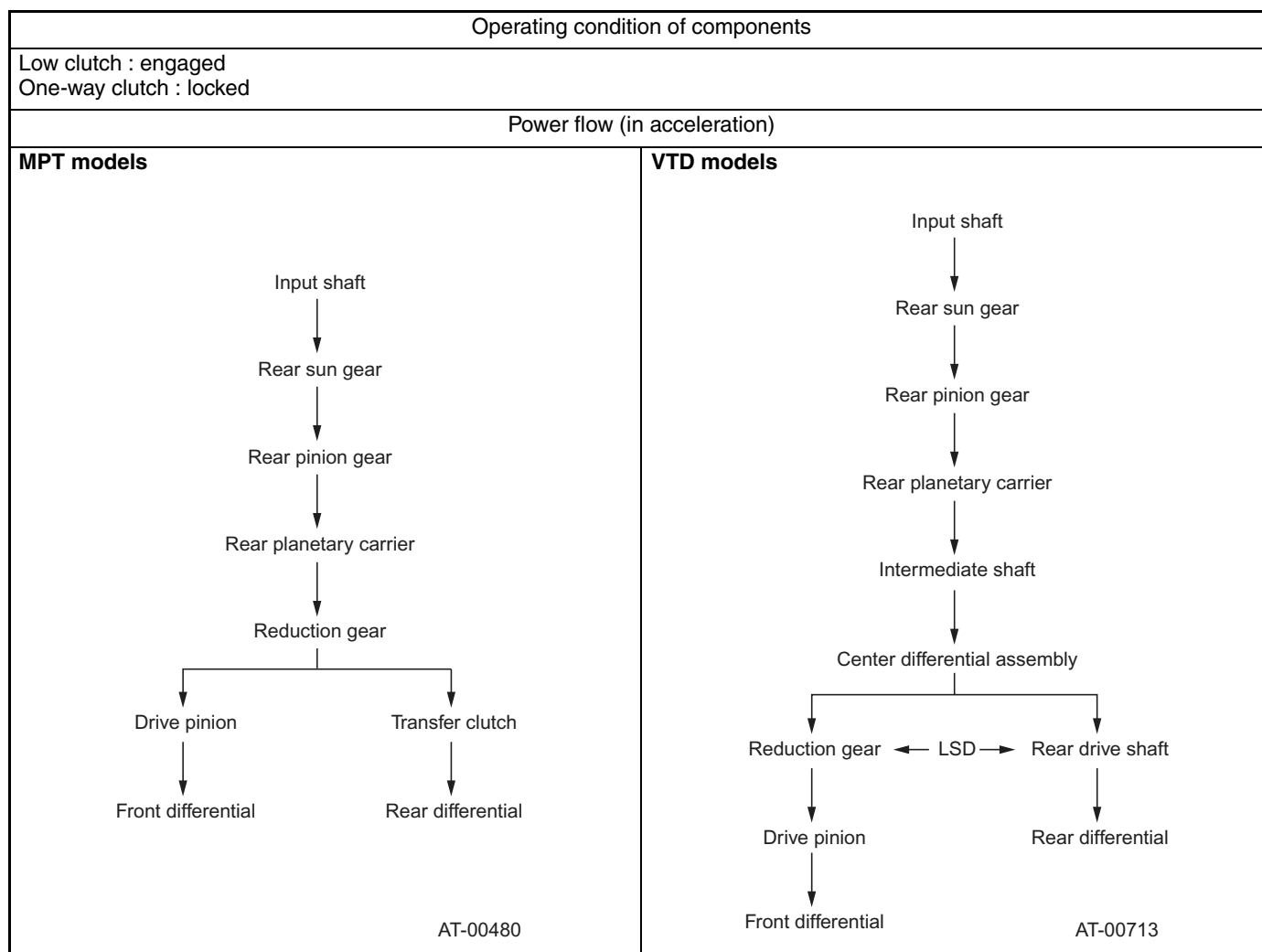

GEAR TRAIN

Automatic Transmission

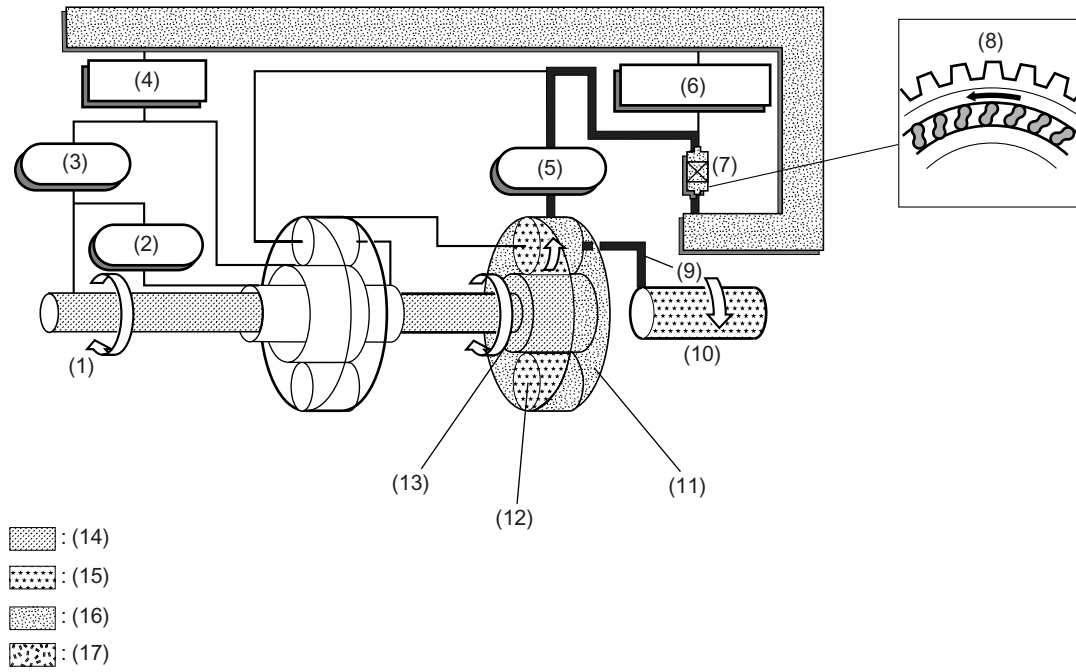

AT-00481

- | | | |
|-------------------------|--|--|
| (1) Input shaft | (7) One-way clutch | (13) Rear sun gear |
| (2) High clutch | (8) Locked | (14) Input |
| (3) Reverse clutch | (9) Rear planetary carrier | (15) Output |
| (4) 2-4 brake | (10) MPT models: Reduction drive shaft
VTD models: Intermediate shaft | (16) Locked |
| (5) Low clutch | (11) Rear internal gear | (17) Planetary gear components
involved in power transmission |
| (6) Low & reverse brake | (12) Rear pinion gear | |

GEAR TRAIN

Automatic Transmission

5. 2ND GEAR OF D, 3, 2 RANGE OR IN SPORTS SHIFT MODE (D_2 , 3_2 , 2_2 , S_2)

When the 2nd gear is selected in D, 3, 2 range or in sports shift mode, the 2-4 brake and the low clutch are engaged. The front sun gear is now locked to the transmission case due to engagement of the 2-4 brake. In this state, the torque of the rear sun gear is transmitted to the rear internal gear through the path of the front internal gear, front pinion gears, low clutch drum and low clutch. At this time, the one-way clutch is freewheeling since the low clutch drum is rotating clockwise.

In this power flow configuration, the rear pinion gears are rotated by the rear internal gear at a speed faster than that available from the configuration for the 1st gear, so the rotation speed of the reduction drive shaft* is higher than that of the 1st gear.

Since the drive power is transmitted without passing through the one-way clutch in the 2nd gear, the backward driving force from the wheels is transmitted through the reduction drive shaft* to the input shaft; this makes the engine braking effect available.



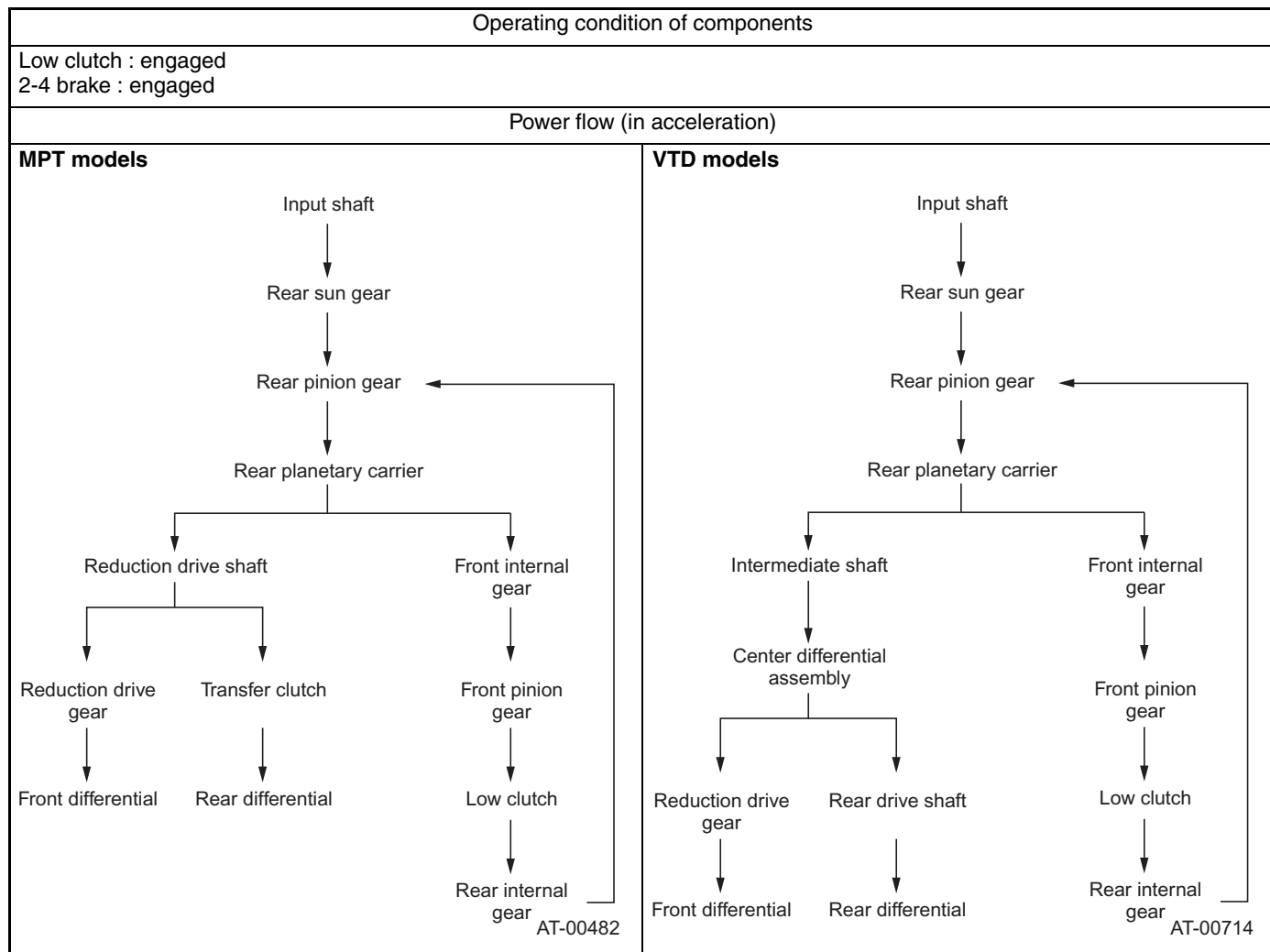

*: MPT models only. VTD models are equipped with an intermediate shaft.

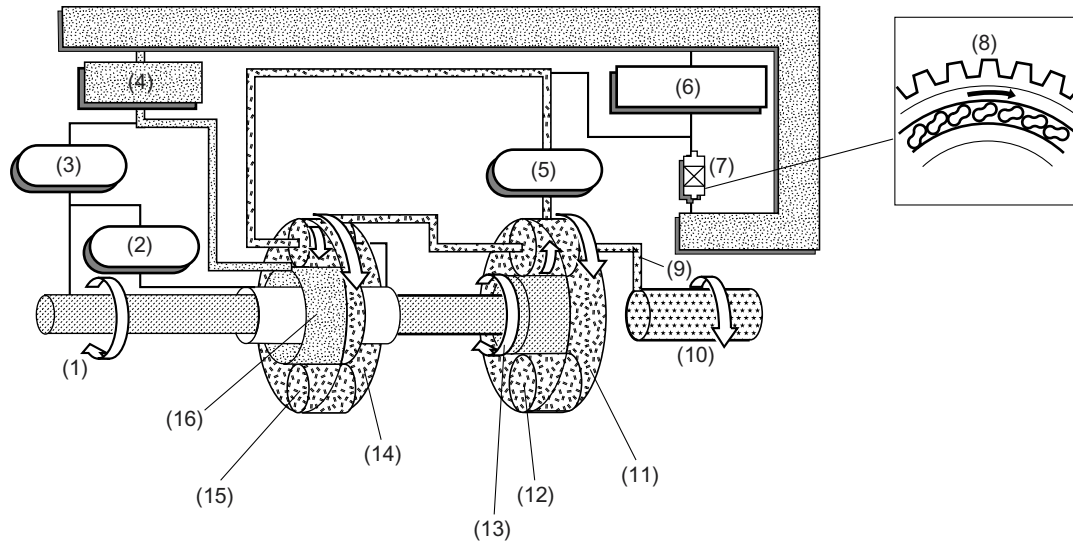

GEAR TRAIN

Automatic Transmission



-  : (17)
-  : (18)
-  : (19)
-  : (20)

AT-00483

- | | | |
|--------------------------|--|--|
| (1) Input shaft | (8) Free | (15) Front pinion gear |
| (2) High clutch | (9) Rear planetary carrier | (16) Front sun gear |
| (3) Reverse clutch | (10) MPT models: Reduction drive shaft
VTD models: Intermediate shaft | (17) Input |
| (4) 2-4 brake | (11) Rear internal gear | (18) Output |
| (5) Low clutch | (12) Rear pinion gear | (19) Locked |
| (6) Low & reverse clutch | (13) Rear sun gear | (20) Planetary gear components
involved in power transmission |
| (7) One-way clutch | (14) Front internal gear | |

GEAR TRAIN

Automatic Transmission

6. 3RD GEAR OF D, 3, RANGE OR IN SPORTS SHIFT MODE (D₃, 3₃, S₃)

When the 3rd gear is selected in the D or 3 range or in sports shift mode, the low clutch and the high clutch are engaged. The engaged high clutch rotates through its drum the front planetary carrier, and rotation of the carrier is transmitted to the rear internal gear through the engaged low clutch. In this power flow configuration, the rear sun gear and the rear internal gear rotate at the same speed since the rear pinion gears are solid on their axes and the whole planetary gear train rotates as a unit at the same speed as its sun gear. As a result, the input shaft and the reduction drive shaft* rotate at the same speed.

In the 3rd gear, the one-way clutch is freewheeling because the low clutch is rotating clockwise. Since the drive power is transmitted without passing through the one-way clutch, the backward driving force from the wheels is transmitted through the reduction drive shaft* to the input shaft; this makes the engine braking effect available.

*: MPT models only. VTD models are equipped with an intermediate shaft.

GEAR TRAIN

Automatic Transmission

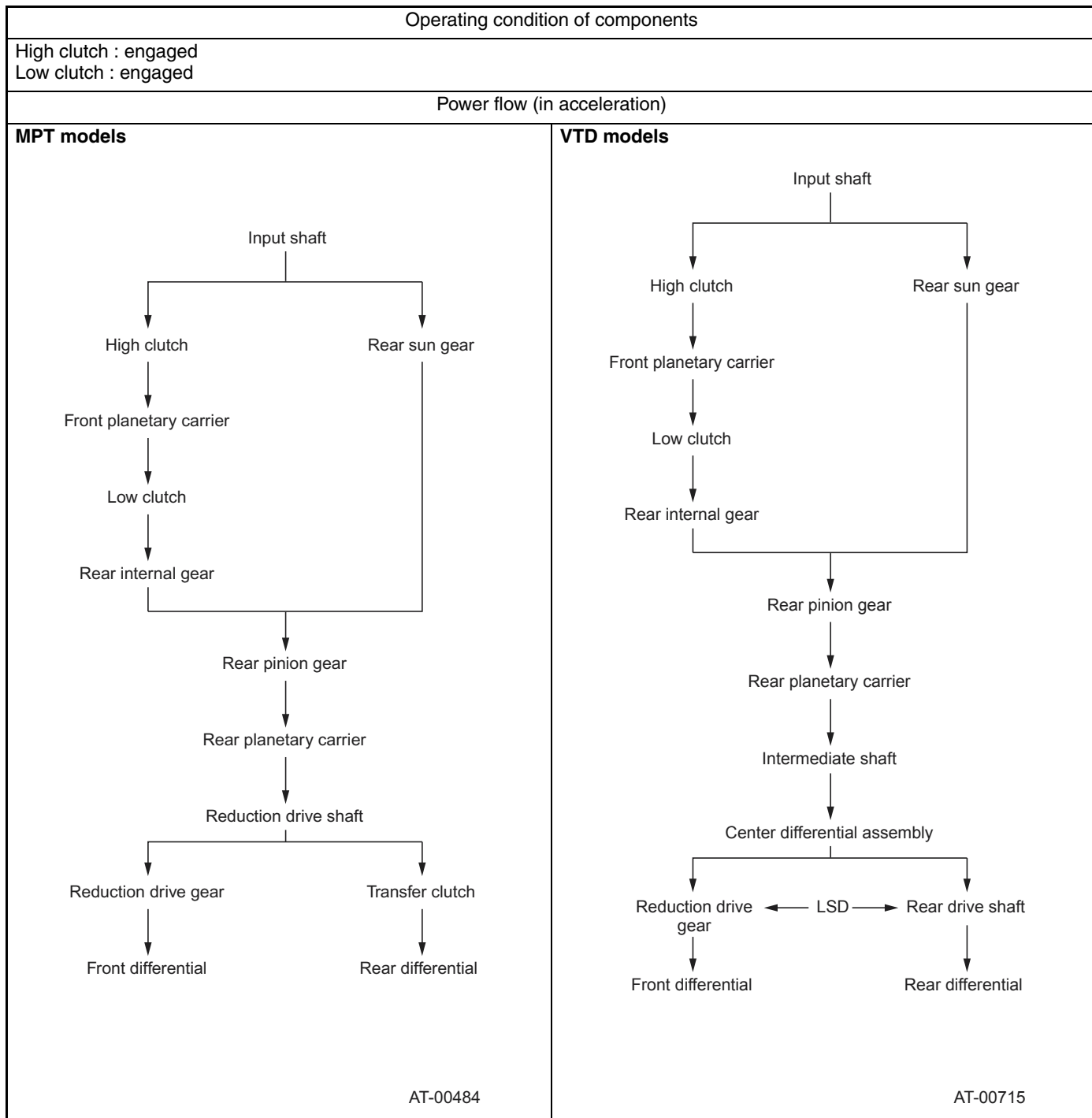

GEAR TRAIN

Automatic Transmission

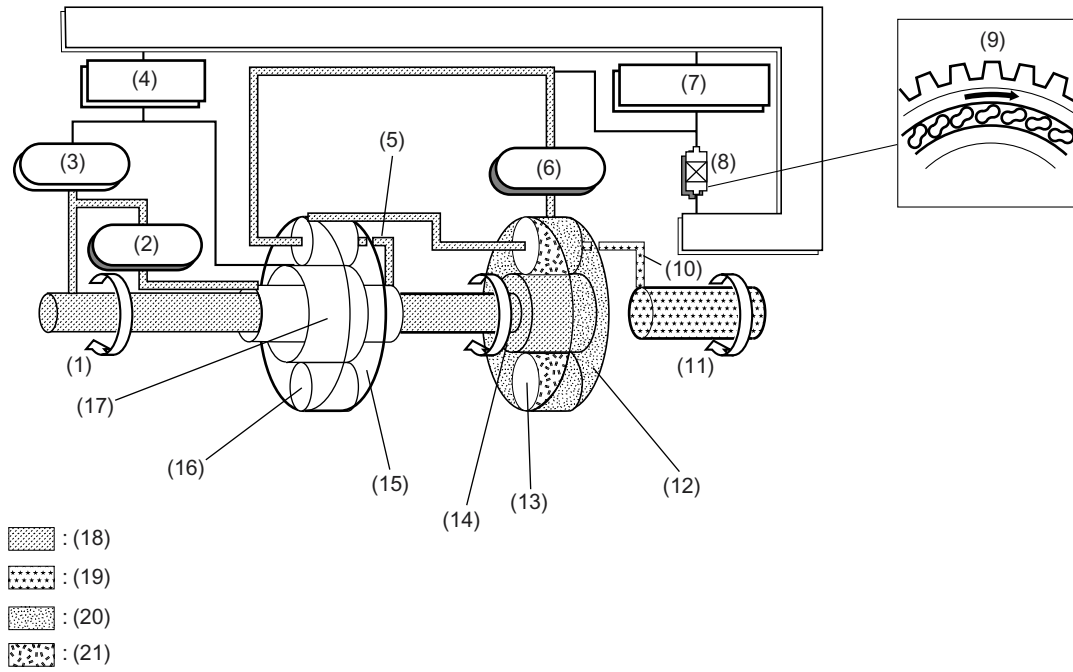

AT-00485

- | | | |
|-----------------------------|--|--|
| (1) Input shaft | (8) One-way clutch | (15) Front internal gear |
| (2) High clutch | (9) Free | (16) Front pinion gear |
| (3) Reverse clutch | (10) Rear planetary carrier | (17) Front sun gear |
| (4) 2-4 brake | (11) MPT models: Reduction drive shaft
VTD models: Intermediate shaft | (18) Input |
| (5) Front planetary carrier | (12) Rear internal gear | (19) Output |
| (6) Low clutch | (13) Rear pinion gear | (20) Locked |
| (7) Low & reverse brake | (14) Rear sun gear | (21) Planetary gear components
involved in power transmission |

GEAR TRAIN

Automatic Transmission

7. 4TH GEAR OF D RANGE OR IN SPORTS SHIFT MODE (D₄, S₄)

When the 4th gear is selected in the D range or in sports shift mode, the high clutch and the 2-4 brake are engaged. The engaged high clutch causes the front planetary carrier to rotate, whereas the engaged 2-4 brake causes the front sun gear to be locked to the transmission case.

The front planetary carrier rotates at the same speed as the input shaft. The rotation of the front planetary carrier causes the front pinion gears to revolve around the stationary front sun gear, which causes the front internal gear to rotate faster than the input shaft.

As a result, the reduction drive shaft* is driven at a higher speed than the input shaft.

In the 4th gear, the one-way clutch is freewheeling because the low clutch is rotating clockwise. Since the drive power is transmitted without passing through the one-way clutch, the backward driving force from the wheels is transmitted through the reduction drive shaft* to the input shaft; this makes the engine braking effect available.



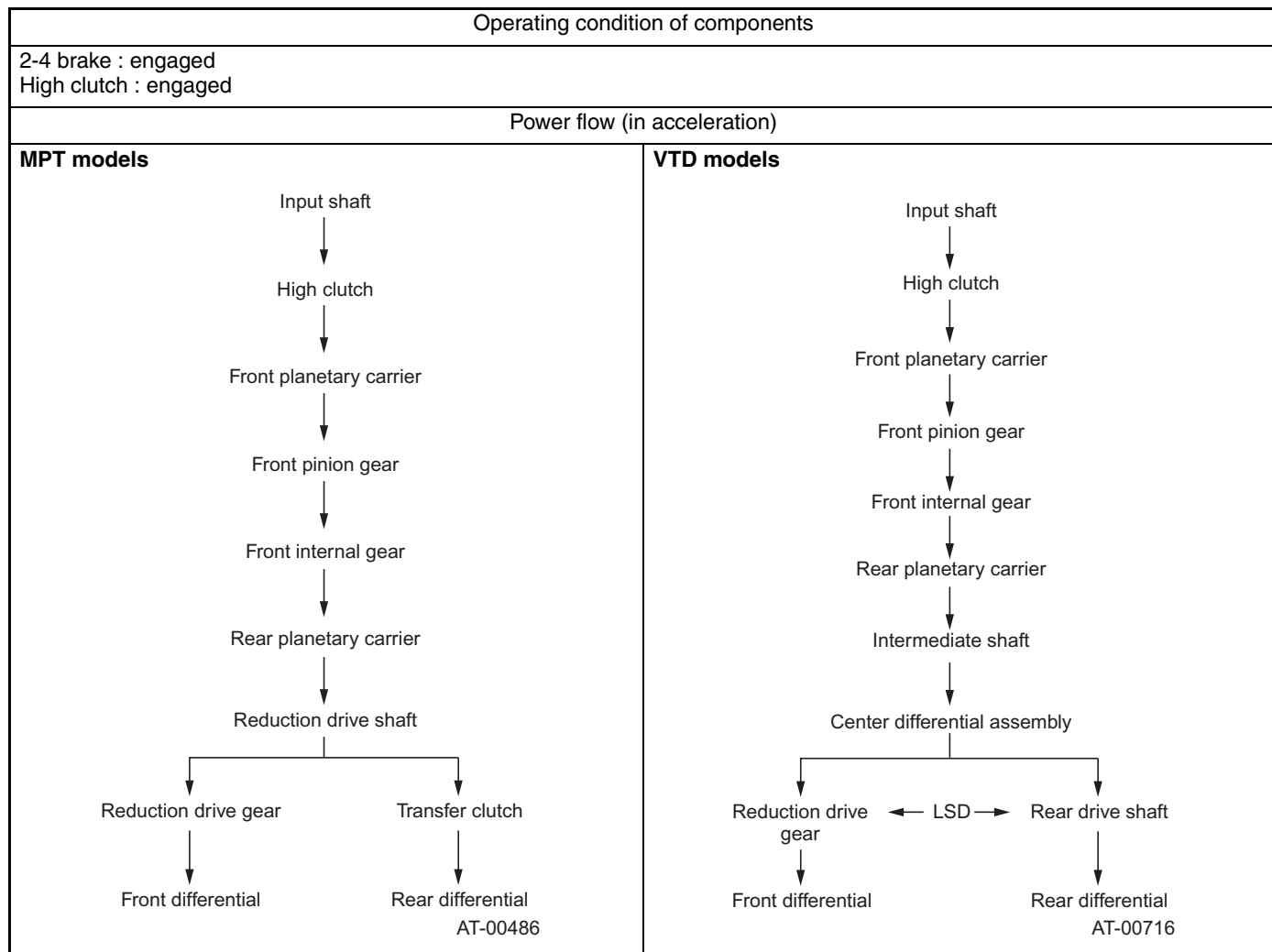

*: MPT models only. VTD models are equipped with an intermediate shaft.

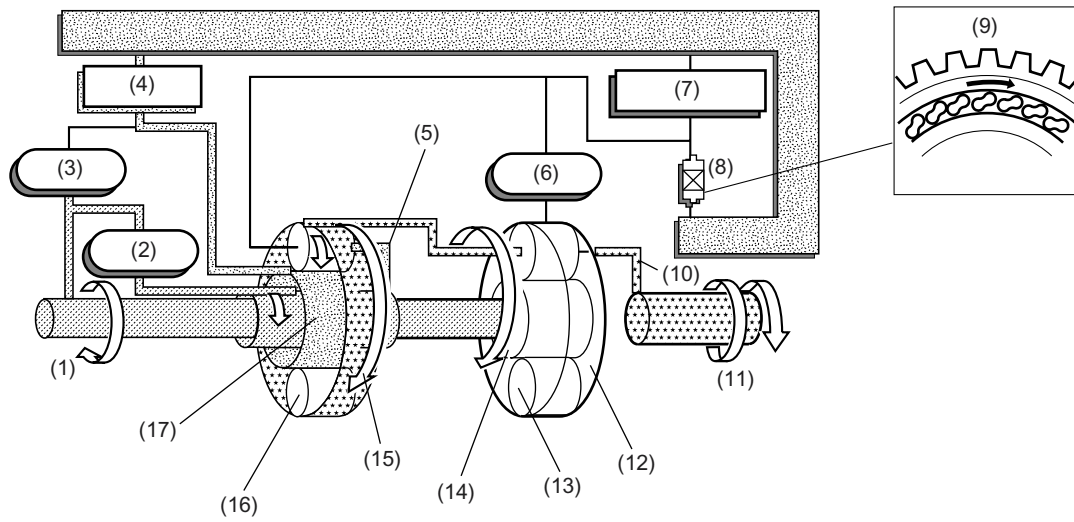

GEAR TRAIN

Automatic Transmission



-  : (18)
-  : (19)
-  : (20)
-  : (21)

AT-00487

- | | | |
|-----------------------------|--|--|
| (1) Input shaft | (8) One-way clutch | (15) Front internal gear |
| (2) High clutch | (9) Free | (16) Front pinion gear |
| (3) Reverse clutch | (10) Rear planetary carrier | (17) Front sun gear |
| (4) 2-4 brake | (11) MPT models: Reduction drive shaft
VTD models: Intermediate shaft | (18) Input |
| (5) Front planetary carrier | (12) Rear internal gear | (19) Output |
| (6) Low clutch | (13) Rear pinion gear | (20) Locked |
| (7) Low & reverse brake | (14) Rear sun gear | (21) Planetary gear components
involved in power transmission |

GEAR TRAIN

8. 1ST GEAR OF 1 RANGE OR IN SPORTS SHIFT MODE (1₁, S₁)

When the 1st gear is selected in the 1 range or in sports shift mode, both the low clutch and the low & reverse brake are engaged. Although the power flow configuration is the same as that with the 1st gear in the D or 3 range, the one-way clutch produces no freewheeling effect because the low & reverse brake is locking the rear internal gear always to the transmission case.

During coasting, therefore, the backward driving force from the wheels is transmitted through the reduction drive gear* to the input shaft. This means, unlike the 1st gear in D or 3 range, that the engine braking effect is available in this range.

* : MPT models only. VTD models are equipped with an intermediate shaft.

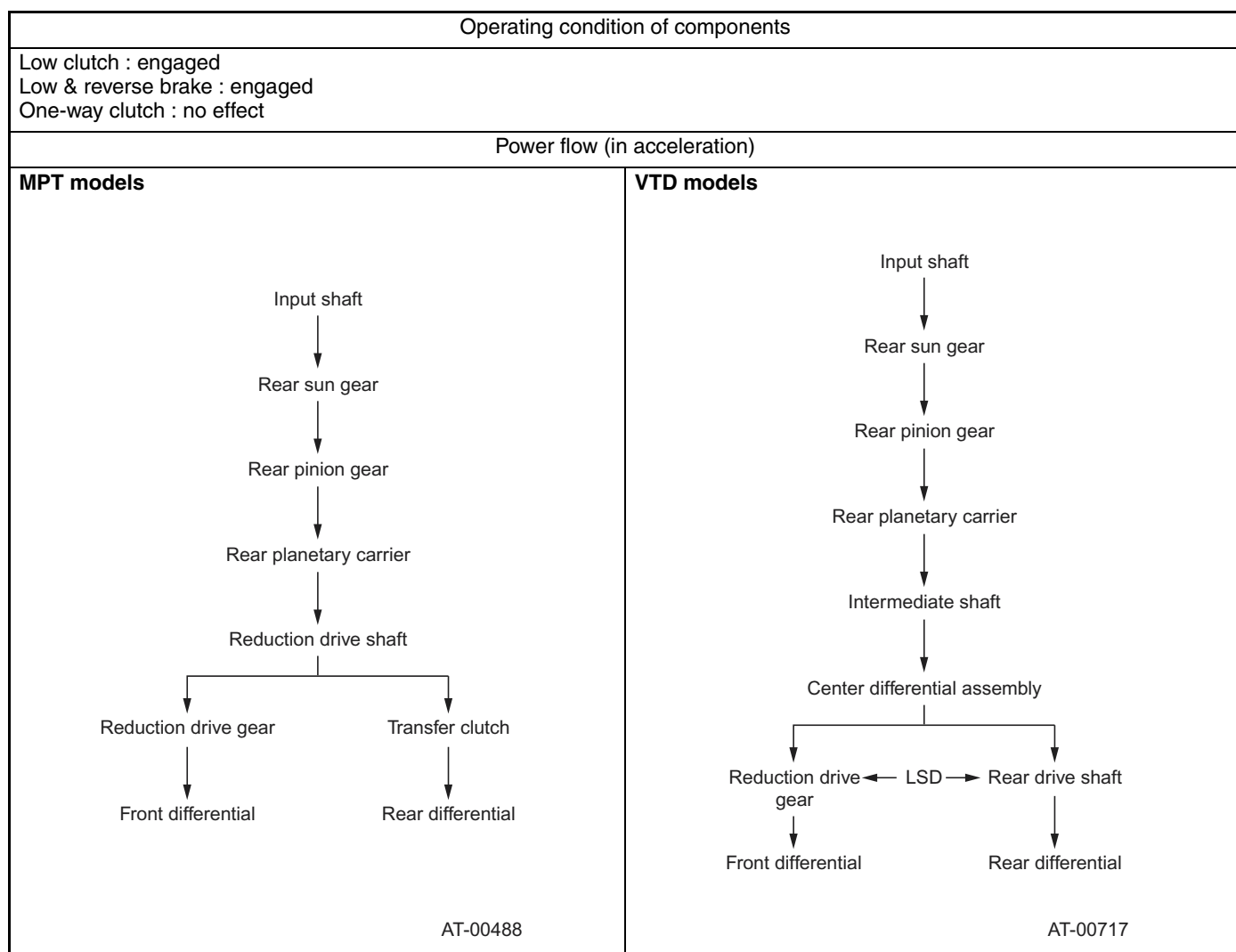

GEAR TRAIN

Automatic Transmission

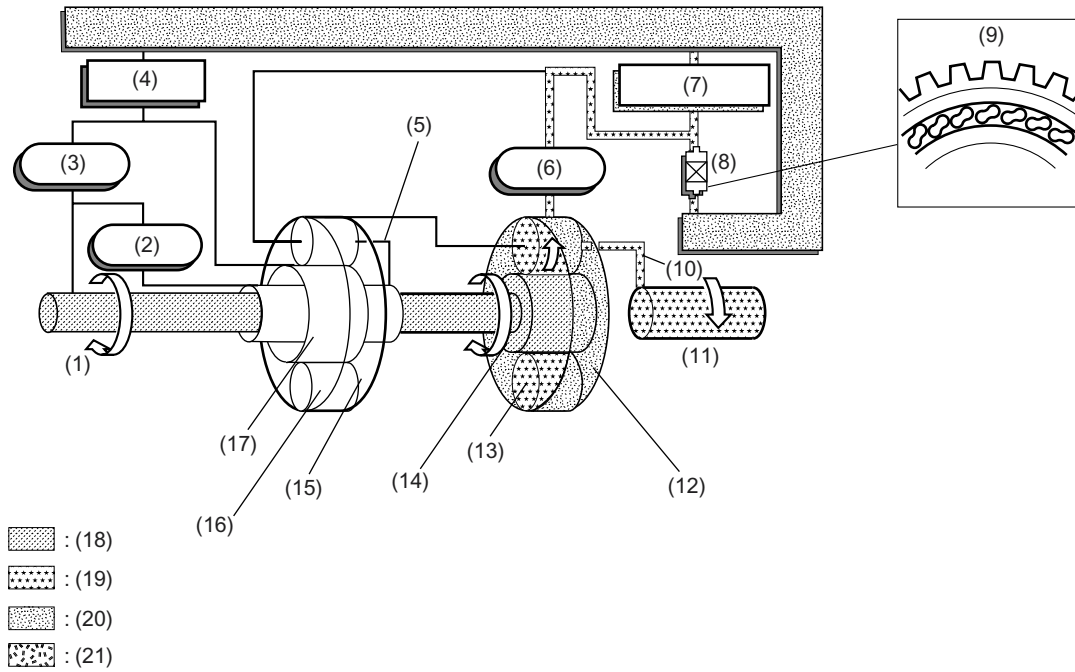

AT-00489

- | | | |
|-----------------------------|--|--|
| (1) Input shaft | (8) One-way clutch | (15) Front internal gear |
| (2) High clutch | (9) No effect | (16) Front pinion gear |
| (3) Reverse clutch | (10) Rear planetary carrier | (17) Front sun gear |
| (4) 2-4 brake | (11) MPT models: Reduction drive shaft
VTD models: Intermediate shaft | (18) Input |
| (5) Front planetary carrier | (12) Rear internal gear | (19) Output |
| (6) Low clutch | (13) Rear pinion gear | (20) Locked |
| (7) Low & reverse brake | (14) Rear sun gear | (21) Planetary gear components
involved in power transmission |

GEAR TRAIN

Automatic Transmission

9. R RANGE

When the selector lever is placed in the R position, the reverse clutch and the low & reverse brake are engaged. The reverse clutch allows the input shaft torque to be transmitted to the front sun gear, while the low & reverse brake allows the low clutch drum to be interlocked with the transmission case.

The rotation of the front sun gear causes the front pinion gear to rotate in the opposite direction and therefore the front internal gear rotates in the same direction.

At this time, the rotation speed transmitted to the front internal gear is reduced through gearing between the front sun gear and the front pinion gears.

The one-way clutch produces no freewheeling effect because the low & reverse brake is in engagement.

In this range, since the power transmission is made without passing through the one-way clutch, the driving force from the wheels is transmitted through the reduction drive shaft* to the input shaft; this makes the engine braking effect available.



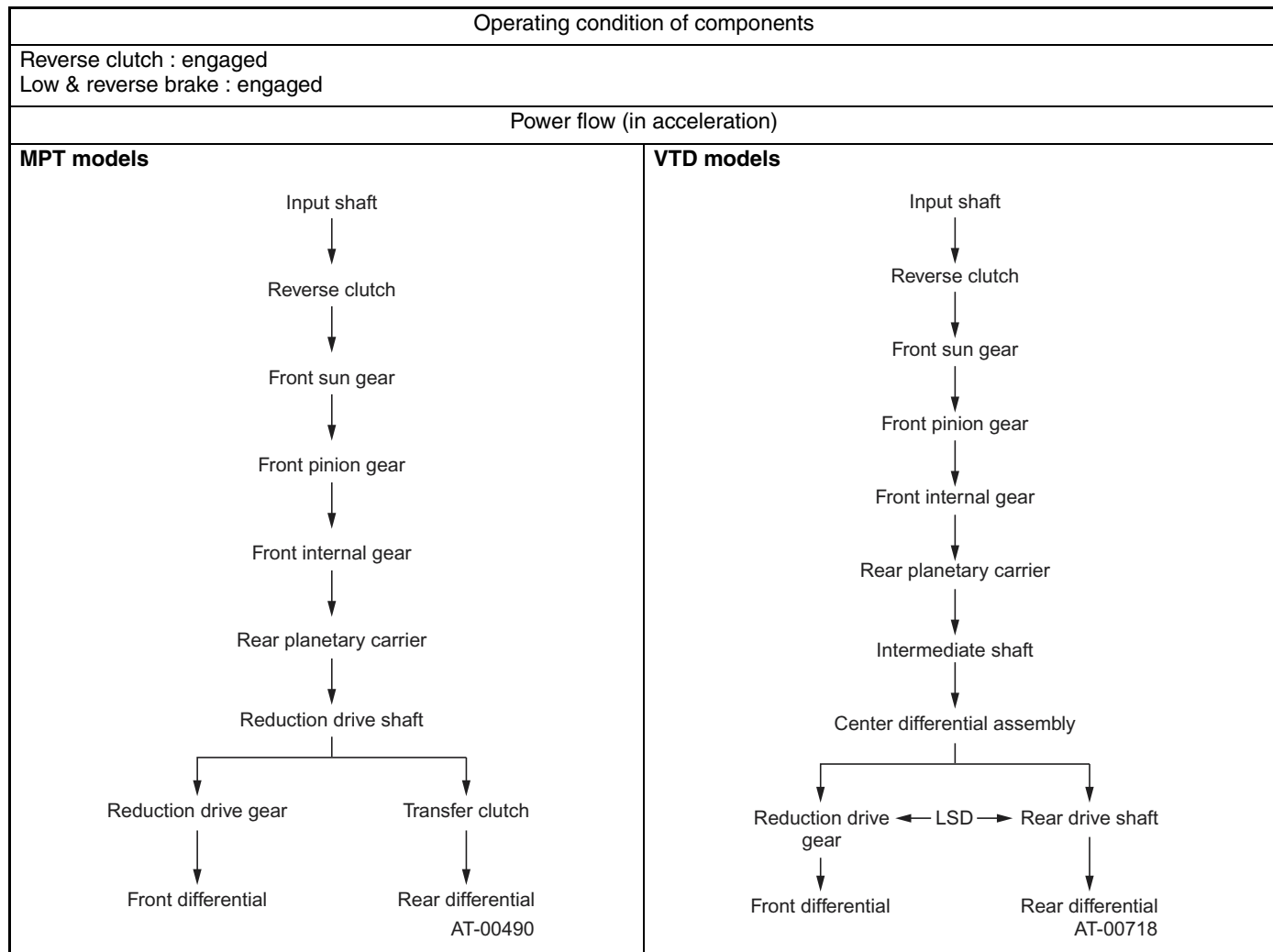

*: MPT models only. VTD models are equipped with an intermediate shaft.

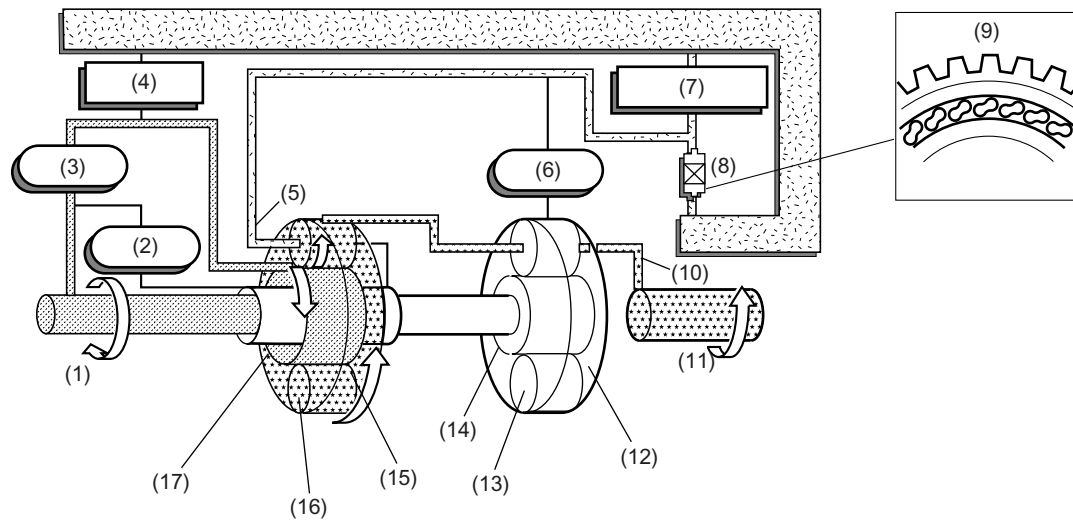

GEAR TRAIN

Automatic Transmission



-  : (18)
-  : (19)
-  : (20)
-  : (21)

AT-00491

- | | | |
|-----------------------------|--|--|
| (1) Input shaft | (8) One-way clutch | (15) Front internal gear |
| (2) High clutch | (9) No effect | (16) Front pinion gear |
| (3) Reverse clutch | (10) Rear planetary carrier | (17) Front sun gear |
| (4) 2-4 brake | (11) MPT models: Reduction drive shaft
VTD models: Intermediate shaft | (18) Input |
| (5) Front planetary carrier | (12) Rear internal gear | (19) Output |
| (6) Low clutch | (13) Rear pinion gear | (20) Locked |
| (7) Low & reverse brake | (14) Rear sun gear | (21) Planetary gear components
involved in power transmission |

GEAR TRAIN

Automatic Transmission

MEMO