

AWD TRANSFER SYSTEM

Automatic Transmission

11.AWD Transfer System

A: MPT MODELS

1. GENERAL

This all-wheel-drive (AWD) transfer system uses an electronically controlled multi-plate type transfer clutch. The clutch is controlled by the TCM through the transfer hydraulic pressure control unit which consists of a duty-cycle-controlled solenoid valve and is located at the rear of the automatic transmission section together with the vehicle speed sensor.

The TCM has in its memory a set of duty ratio data, each defining at what ratio the transfer clutch should transmit the torque for a particular driving condition. Based on the driving condition information it receives from the corresponding sensors (vehicle speed, throttle opening, gear range, slip of wheels, etc.), the TCM selects an appropriate duty ratio from the memory and uses it to control the solenoid valve. The solenoid valve then regulates the pilot pressure of the transfer control valve which creates the pressure to the clutch from the line pressure. The clutch is engaged to a degree determined by the transfer clutch pressure thus created. Through this process, the torque from the engine is distributed to the rear wheels optimally according to driving conditions.

AWD TRANSFER SYSTEM

Automatic Transmission

2. CONSTRUCTION

● Transfer clutch

The transfer clutch drum and rear drive shaft are joined to each other by welding. The rear drive shaft has drilled oil passages for transfer clutch control and also for lubrication of extension bushing and ball bearing in it.

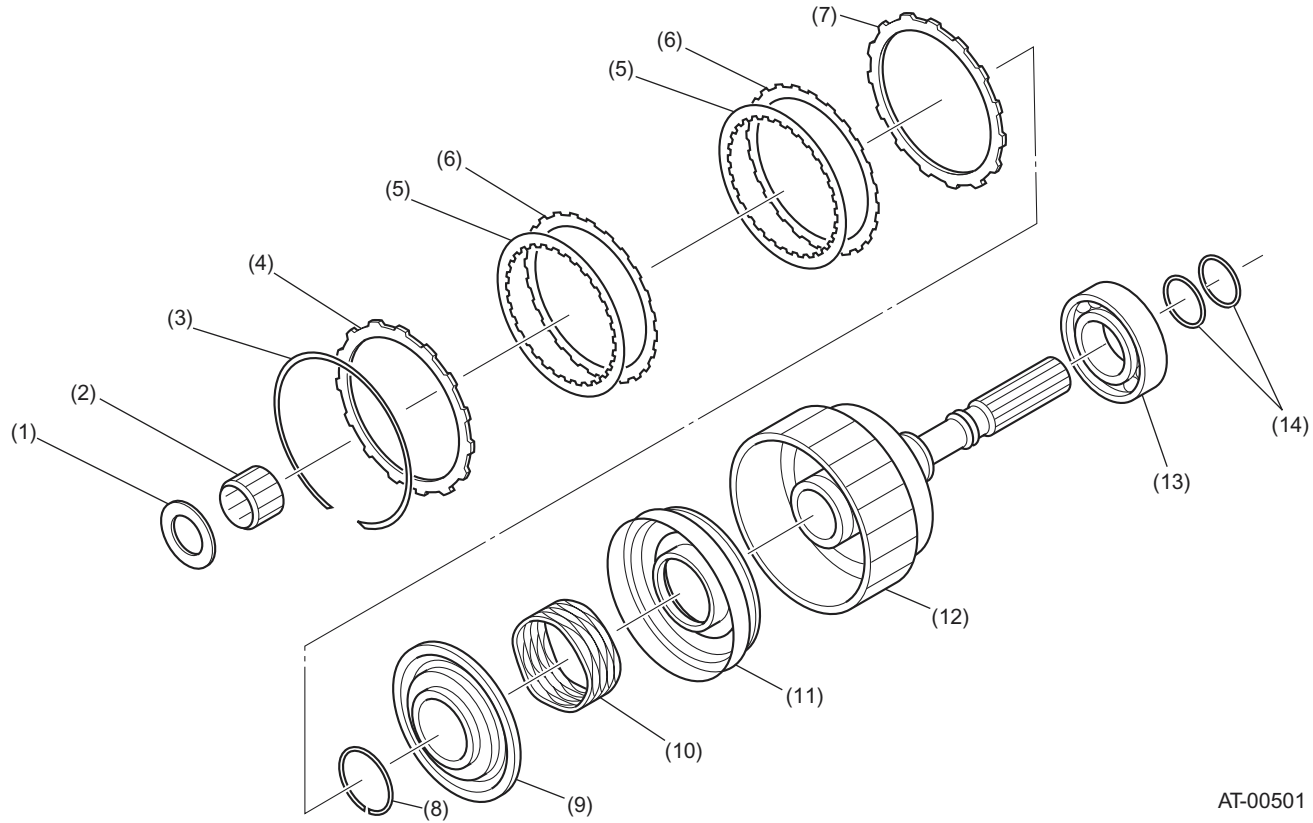

AT-00501

- (1) Thrust bearing
- (2) Needle bearing
- (3) Snap ring
- (4) Pressure plate
- (5) Drive plate

- (6) Driven plate
- (7) Pressure plate
- (8) Snap ring
- (9) Transfer piston seal
- (10) Return spring

- (11) Transfer clutch piston
- (12) Rear drive shaft
- (13) Ball bearing
- (14) Seal ring

AWD TRANSFER SYSTEM

Automatic Transmission

- Transfer hydraulic pressure control unit

The transfer hydraulic pressure control unit is bolted at the rear end of transmission case through the transfer valve plate.

The hydraulic pressures used for the transfer hydraulic pressure control unit (line pressure and pilot pressure) are supplied from the transmission's hydraulic control valve assembly through the passages formed in the transmission case.

The transfer duty solenoid adjusts the pilot pressure of the transfer clutch valve depending on the signals from the TCM. The transfer clutch valve in turn modulates the line pressure into the transfer clutch pressure before it is applied to the clutch piston.

The transfer clutch pressure adjusted in this way engages the clutch to different degrees according to driving conditions so that the optimum torque is distributed to the rear wheels.

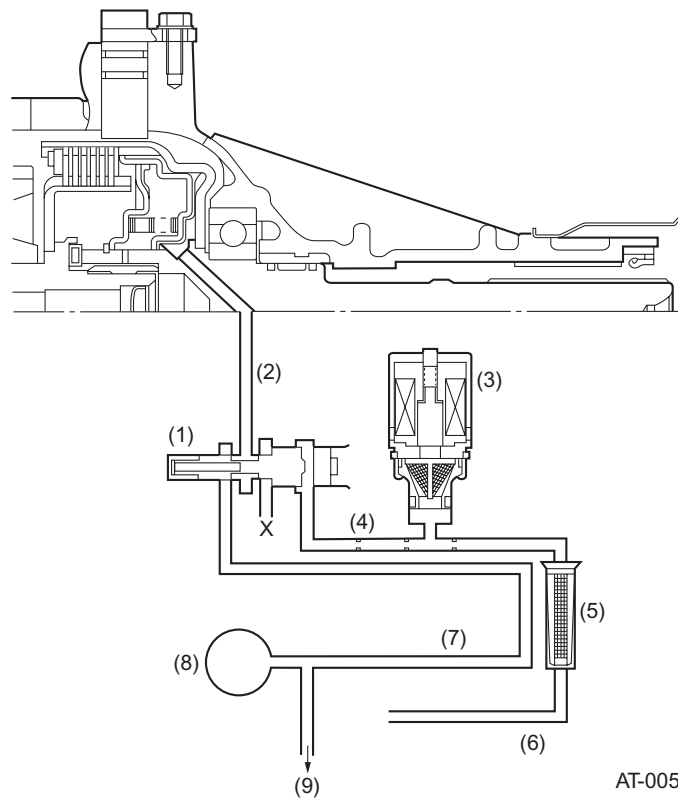

- (1) Transfer control valve
- (2) Transfer clutch pressure
- (3) Transfer duty solenoid

- (4) Transfer pressure
- (5) Filter
- (6) Pilot pressure

- (7) Line pressure
- (8) Oil pump
- (9) Transmission hydraulic control valve assembly

AWD TRANSFER SYSTEM

Automatic Transmission

B: VTD MODELS

1. GENERAL

Used in the transfer of the VTD models is the SUBARU drive power distribution system which combines a compound planetary gear type center differential installed in the transfer case behind the transmission and a hydraulically operated multi-plate differential action limiting device (LSD) located between the output components of the center differential. Differential action limiting control is performed by the TCM according to driving and road surface conditions. This system allows combining stability provided by the AWD design with good operability.

The input torque is transmitted to the 1st sun gear of the center differential through the intermediate shaft. From the 1st sun gear, the torque is transmitted through the 1st pinion to the output carrier in the front wheel output components, and through the 2nd pinion to the 2nd sun gear in the rear wheel output components.

The center differential performs the differential functions of absorbing the speed difference between the front and rear wheels and also distributes drive forces to the front and rear wheels at a predetermined ratio. In normal conditions (when there is almost no difference in the speed between the front and rear wheels), the drive force distribution ratio is 45.5 % to the front wheels and 54.5 % to the rear wheels. The hydraulic multi-plate clutch connected in parallel with the center differential between the carrier and 2nd sun gear functions as a differential action limiting device (LSD) and also as a device that controls torque distribution according to driving conditions.

The differential action limiting control is based on the parameters that include the throttle angle, engine speed, vehicle speed, and speed ratio of front and rear wheels. The LSD clutch piston is operated by the fluid whose pressure is adjusted by the duty solenoid and the transfer control valve in the transfer case. According to the pressure applied to the piston, the torque distribution ratio changes from the ratio set for the center differential to the direct AWD ratio.

The speed of the front and rear wheels determine the basic signals for the differential action limiting control. The rear wheel speed is detected by sensor installed above the rear drive shaft and the front wheel speed is detected by the sensor on the parking gear above the reduction drive shaft gear.

AWD TRANSFER SYSTEM

Automatic Transmission

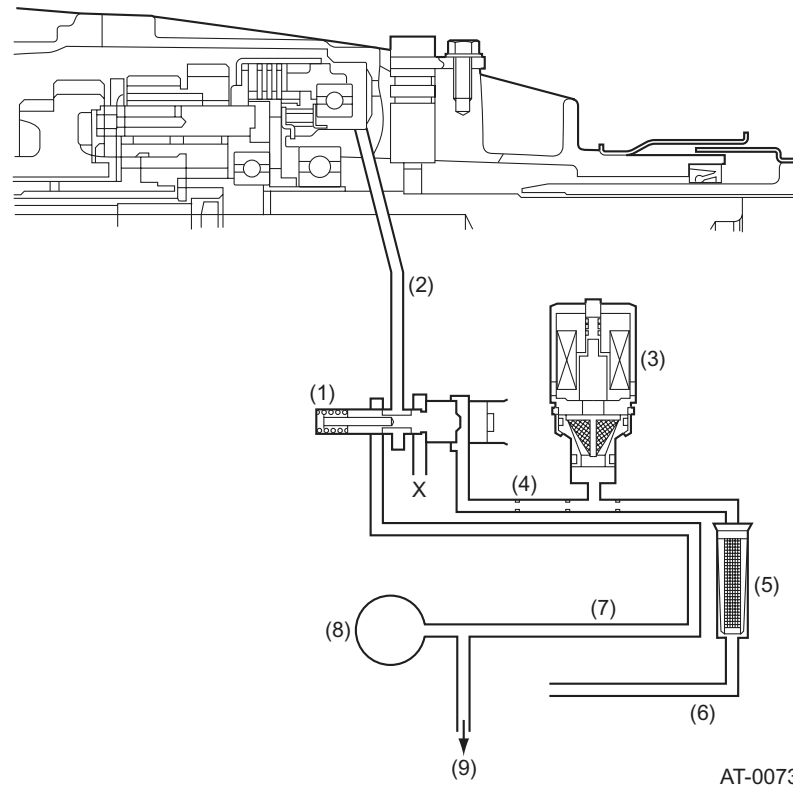

- | | | |
|------------------------------|-----------------------|---|
| (1) Transfer control valve | (4) Transfer pressure | (7) Line pressure |
| (2) Transfer clutch pressure | (5) Filter | (8) Oil pump |
| (3) Transfer duty solenoid | (6) Pilot pressure | (9) Transmission hydraulic control valve assembly |

AWD TRANSFER SYSTEM

Automatic Transmission

2. VARIABLE TORQUE DISTRIBUTION CENTER DIFFERENTIAL

The front-rear torque distribution ratio is basically determined by the gear tooth ratio of center differential's compound planetary gears and varied by changing the degree of engagement of the hydraulically operated multi-plate clutch that connects the center differential output elements according to driving conditions and road surface conditions. The torque distribution ratio is calculated using the following equations which include torque distribution coefficients (determined by number of gear teeth), input torque to the center differential, and torque capacity of the multi-plate clutch as factors.

1) When the front wheel speed is higher than the rear wheel speed:

$$T_R = 0.545 \times T_i + T_C$$

$$T_F = 0.455 \times T_i - T_C$$

where

T_R : Rear wheel output torque

T_i : Input torque to center differential

T_C : Torque capacity of multi-plate clutch

T_F : Front wheel output torque

0.545: Coefficient of rear wheel torque determined by number of gear teeth

0.455: Coefficient of front wheel torque determined by number of gear teeth

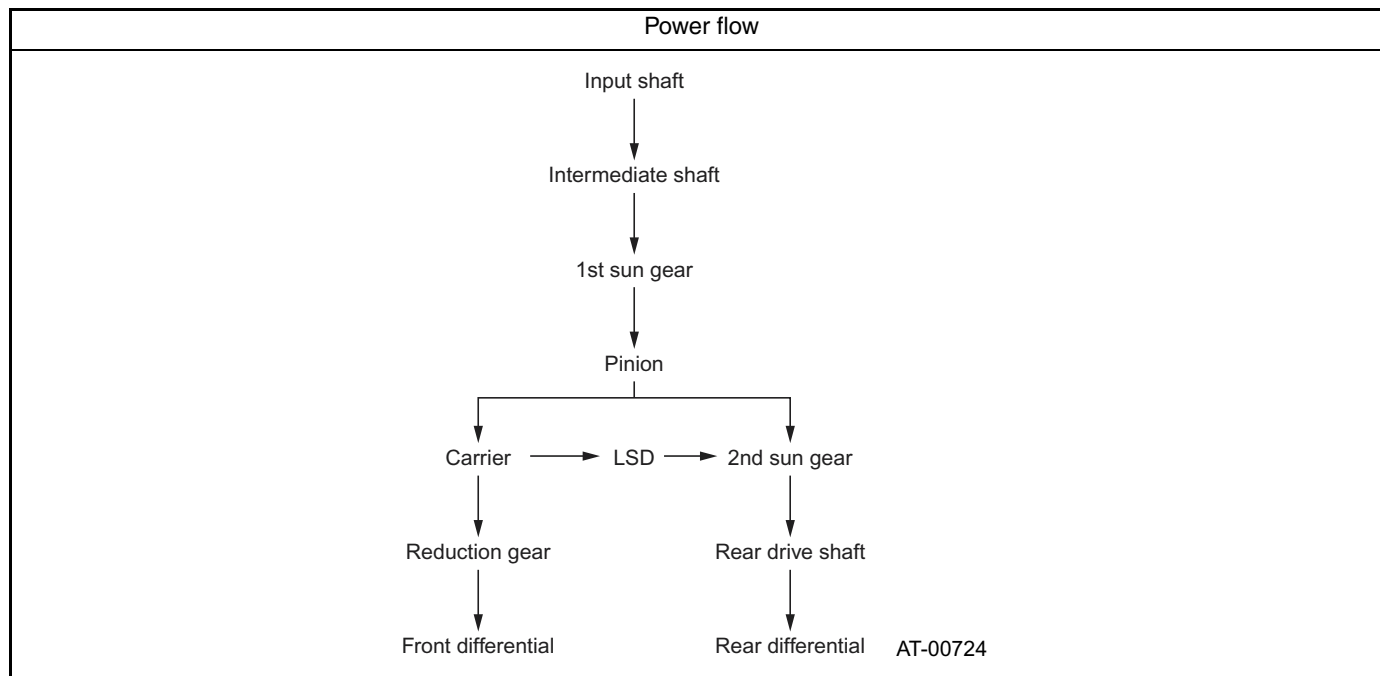

AWD TRANSFER SYSTEM

Automatic Transmission

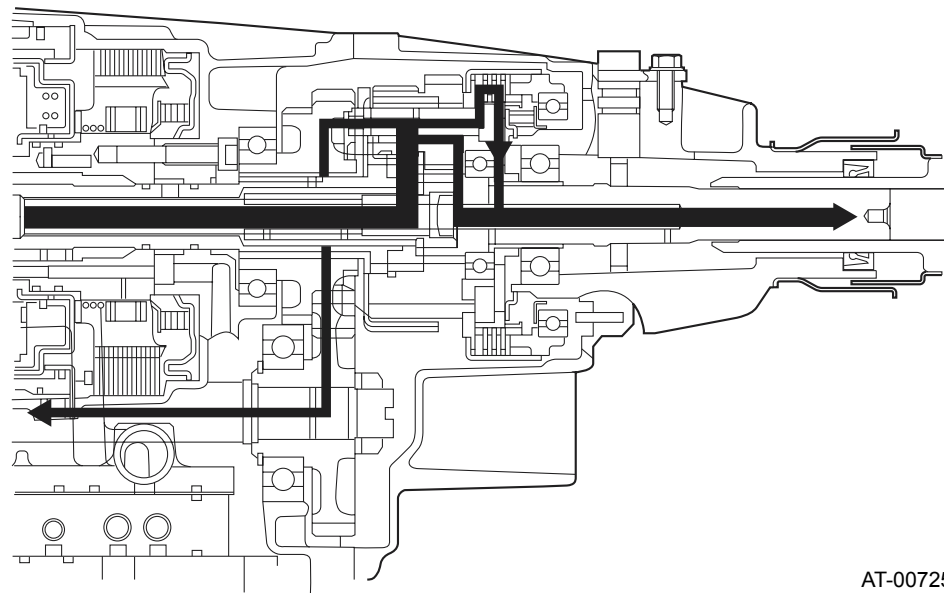

AT-00725

2) When the rear wheel speed is higher than the front wheel speed:

$$T_R = 0.545 \times T_i - T_C$$

$$T_F = 0.455 \times T_i + T_C$$

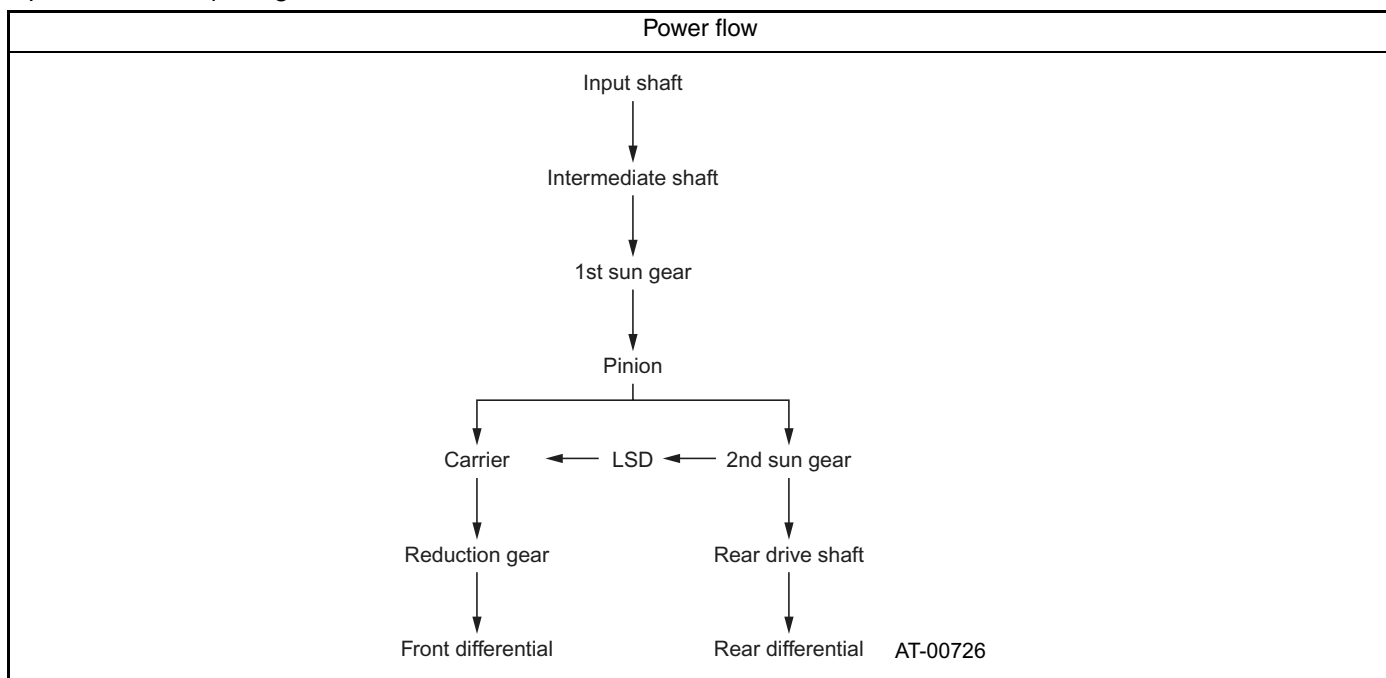

AWD TRANSFER SYSTEM

Automatic Transmission

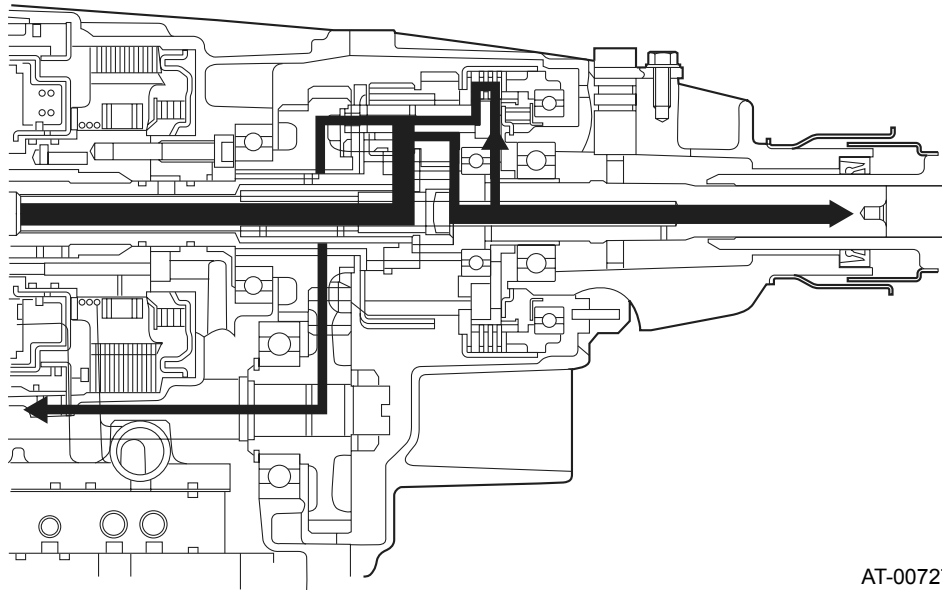

Calculation of front and rear wheel torques

If the frictional resistance resulting from meshing of the planetary gears and sliding of rotational components are ignored, the torques distributed to the front and rear wheels are expressed by the following equations:

$$T_R = [(Z_{P1} \times Z_{S2}) \div (Z_{S1} \times Z_{P2})] \times T_i$$
$$T_F = [1 - (Z_{P1} \times Z_{S2}) \div (Z_{S1} \times Z_{P2})] \times T_i$$

where

Z_{P1} : Number of teeth of 1st planetary gear

Z_{P2} : Number of teeth of 2nd planetary gear

Z_{S1} : Number of teeth of 1st sun gear

Z_{S2} : Number of teeth of 2nd sun gear

T_i : Input torque

If the number of teeth in each component is the same as that assumed in the equations on the previous page, the following ratios are the calculation results of the equations shown above.

$$T_R = 0.545 \times T_i$$

$$T_F = 0.455 \times T_i$$

As a result, the front-rear torque distribution ratio of the compound planetary gear set without an adjustment by the multi-plate clutch is 45.5 : 54.5.

AWD TRANSFER SYSTEM

Automatic Transmission

MEMO

AT-81

AWD TRANSFER SYSTEM

Automatic Transmission

3. CENTER DIFFERENTIAL ASSEMBLY

The center differential is a compound planetary gear set without internally-toothed gears. The input torque from the automatic transmission is transmitted to the input element of the center differential (1st sun gear). The front wheel output elements of the center differential are connected to the carrier and the rear wheel output elements are connected to the 2nd sun gear.

The compound planetary gears uses helical gears for quiet operation and strength. The three pinions are arranged to ensure the best motion balance during operation.

AWD TRANSFER SYSTEM

Automatic Transmission

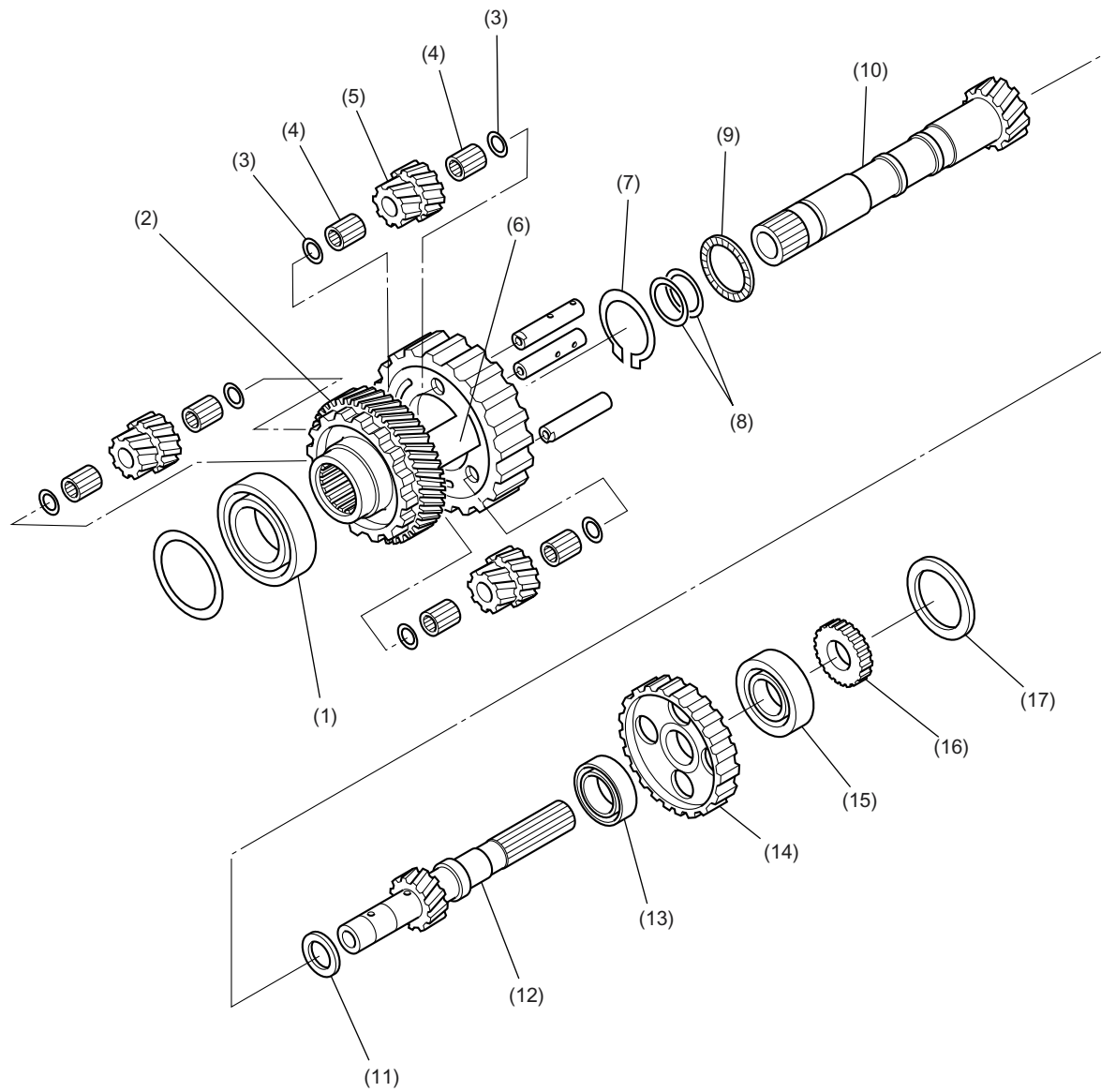

AT-00728

- | | | |
|--------------------------|---------------------------|-----------------------------|
| (1) Ball bearing | (7) Snap ring | (13) Ball bearing |
| (2) Reduction drive gear | (8) Seal ring | (14) Multi-plate clutch hub |
| (3) Washer | (9) Thrust needle bearing | (15) Ball bearing |
| (4) Needle bearing | (10) Intermediate shaft | (16) Revolution gear |
| (5) Pinion gear | (11) Thrust washer | (17) Rear drive shaft shim |
| (6) Carrier | (12) Rear drive shaft | |

AWD TRANSFER SYSTEM

Automatic Transmission

4. MULTI-PLATE CLUTCH (LSD)

The transfer's differential action limiting device (LSD) consists of a multi-plate clutch and a transfer hydraulic pressure control unit incorporating a transfer duty solenoid.

The transfer duty solenoid is an electromagnetic valve which is controlled by the TCM using various duty ratios stored in its memory as explained in "1. GENERAL".

The rear drive shaft has drilled oil passages for lubrication of multi-plate clutch and extension bushing and ball bearing in it.

AWD TRANSFER SYSTEM

Automatic Transmission

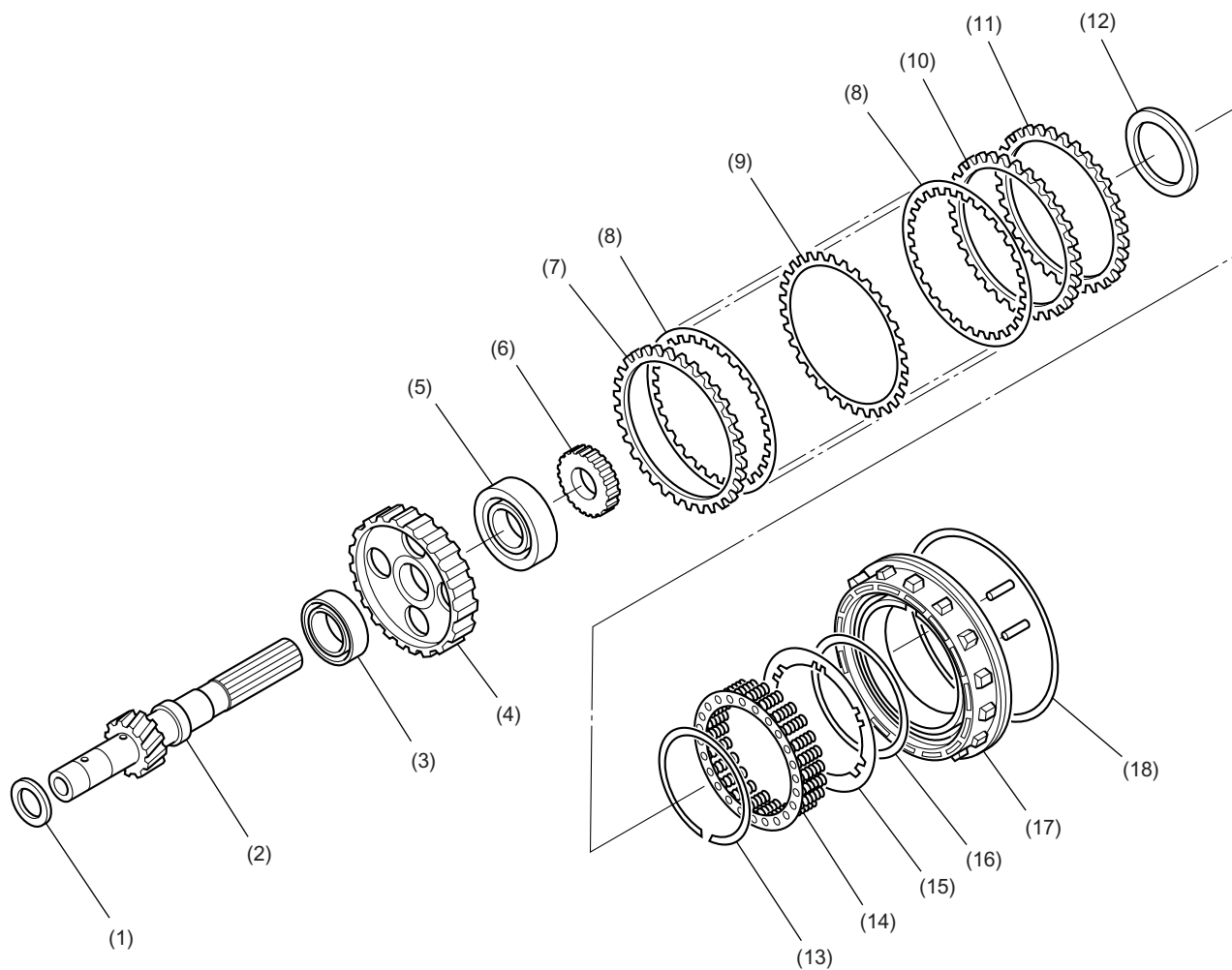

AT-00729

- | | | |
|----------------------------|-----------------------------|--------------------------------|
| (1) Thrust washer | (7) Driven plate (thicker) | (13) Snap ring |
| (2) Rear drive shaft | (8) Drive plate | (14) Spring retainer |
| (3) Ball bearing | (9) Driven plate (thinner) | (15) Plate |
| (4) Multi-plate clutch hub | (10) Driven plate (thicker) | (16) Lathe cut seal ring |
| (5) Ball bearing | (11) Adjust plate | (17) Multi-plate clutch piston |
| (6) Revolution gear | (12) Rear drive shaft shim | (18) Lathe cut seal ring |

AWD TRANSFER SYSTEM

Automatic Transmission

5. TRANSFER HYDRAULIC PRESSURE CONTROL UNIT

The transfer hydraulic pressure control unit is bolted at the rear end of transmission case through the transfer valve plate.

The hydraulic pressures used for the transfer hydraulic pressure control unit (line pressure and pilot pressure) are supplied from the transmission's hydraulic control valve assembly through the passages formed in the transmission case.

The transfer duty solenoid adjusts the pilot pressure of the transfer control valve depending on the signals from the TCM. The transfer control valve in turn modulates the line pressure into the transfer clutch pressure before it is applied to the clutch piston.

The transfer clutch pressure adjusted in this way engages the clutch to different degrees according to driving conditions so that the optimum torque is distributed to the rear wheels.

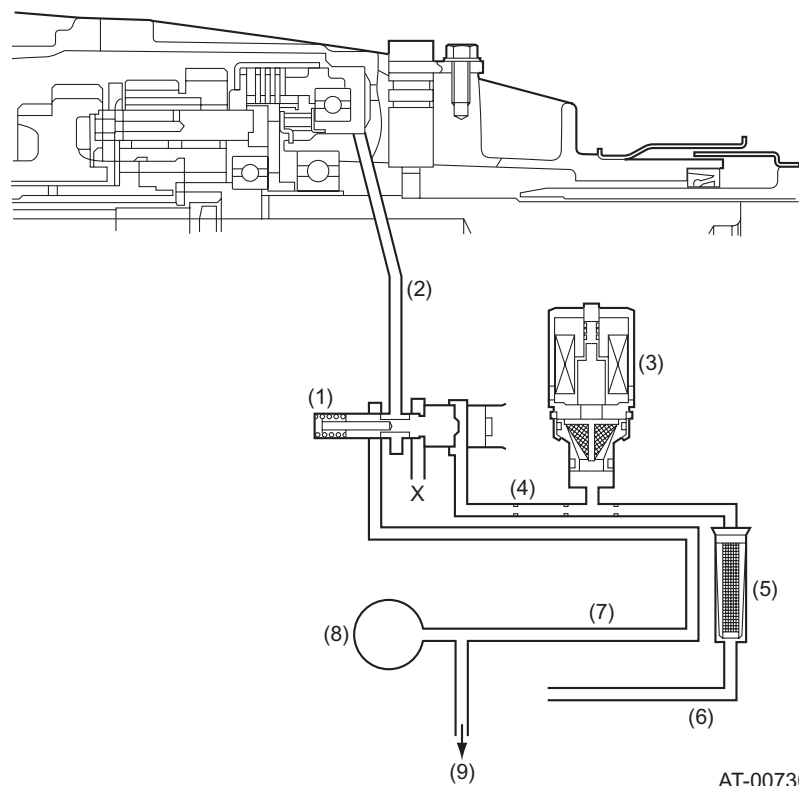

AT-00730

- | | | |
|------------------------------|-----------------------|---|
| (1) Transfer control valve | (4) Transfer pressure | (7) Line pressure |
| (2) Transfer clutch pressure | (5) Filter | (8) Oil pump |
| (3) Transfer duty solenoid | (6) Pilot pressure | (9) Transmission hydraulic control valve assembly |