

ON-BOARD DIAGNOSTICS SYSTEM

Automatic Transmission

14. On-board Diagnostics System

A: FUNCTION

The on-board diagnostics system detects and stores in the form of a code a fault that has occurred in any of the following input and output signal systems.

Rear vehicle speed sensor	Transfer duty solenoid	Low-clutch timing solenoid
Front vehicle speed sensor	ATF temperature sensor	Torque converter turbine speed sensor
Throttle position sensor	Engine speed signal circuit	Sports shift solenoid
Shift solenoid 1	Line pressure duty solenoid	VDC communication system
Shift solenoid 2	AT load signal circuit	—
2-4 brake timing solenoid	Torque control signal circuit	—
Lock-up duty solenoid	2-4 brake duty solenoid	—

If a fault has been detected, the system tells the fault by causing the AT OIL TEMP warning light to operate as follows:

- Repeated flashing at 4 Hz frequency ...Errors such as battery trouble
- Repeated flashing at 2 Hz frequency ...No faults in the system
- Flashing at different intervals and frequencies ...Diagnostic trouble codes of corresponding faults
- Continued illumination of light ...Fault in inhibitor switch, idle switch, or wiring

ON-BOARD DIAGNOSTICS SYSTEM

Automatic Transmission

B: OPERATION OF AT OIL TEMP WARNING LIGHT

On starting the engine, the AT OIL TEMP warning light illuminates and then goes out as shown in the "Normal" diagram below. If any problem exists, the warning light continues flashing as shown in the Abnormal diagram below.

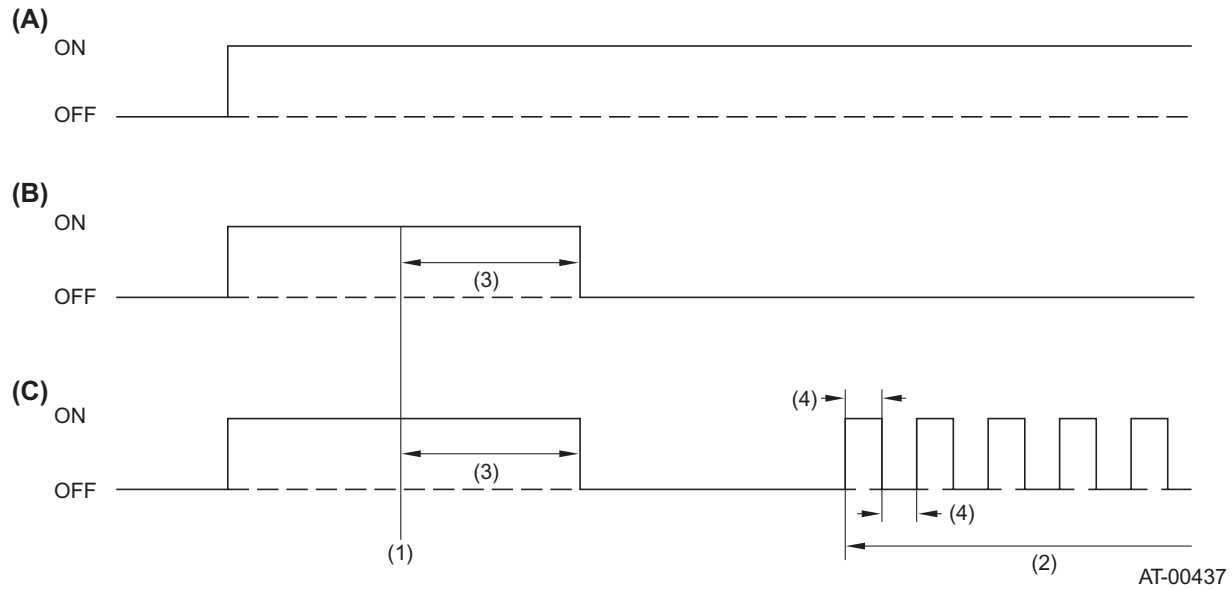

- (A) Ignition switch ON (engine OFF)
- (B) Normal
- (C) Abnormal

- (1) Engine cranking
- (2) Blink
- (3) 2 seconds
- (4) 0.3 seconds

ON-BOARD DIAGNOSTICS SYSTEM

Automatic Transmission

C: DIAGNOSTIC TROUBLE CODES

DTC	Faulty component
11	Engine speed signal circuit
27	ATF temperature sensor
31	Throttle position sensor
33	Front vehicle speed sensor
36	Torque converter turbine speed sensor
38	Torque control signal circuit
45	Intake manifold pressure signal circuit
71	Shift solenoid 1
72	Shift solenoid 2
73	Low-clutch timing solenoid
74	2-4 brake timing solenoid
75	Line pressure duty solenoid
76	2-4 brake duty solenoid
77	Lock-up duty solenoid
78	Sports shift solenoid
79	Transfer duty solenoid
86	VDC communication
93	Rear vehicle speed sensor

D: SELECT MONITOR

Various sensor and switch data as well as diagnostic trouble codes for faults that are currently present and occurred in the past can be monitored by connecting the select monitor to the select monitor terminal located under the instrument panel.