

FRONT AND REAR DISC BRAKES

Brakes

1. Front and Rear Disc Brakes

- The front disc brakes are of a ventilated disc type which features high heat dissipation and superb braking stability. In addition, the front brakes quickly restore their original braking performance even when they get wet.
- The rear brakes are disc brakes.
- Each disc rotor, which is fitted on the outside of the hub, is secured together with the wheel using the hub bolts. This facilitates its removal and installation.
- The inner brake pad is provided with a wear indicator.

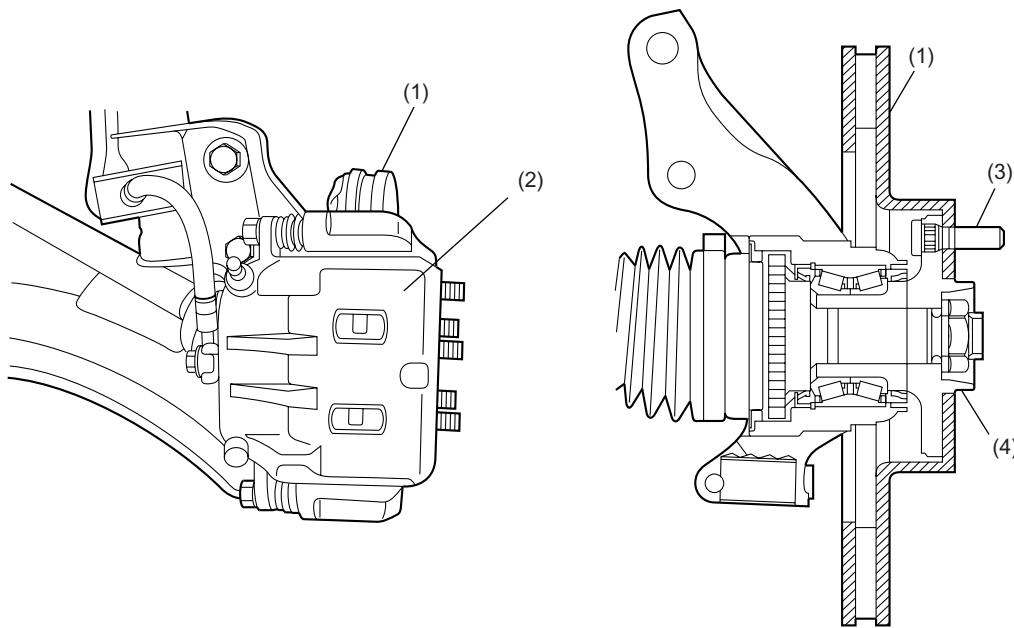

BR-00011

- (1) Disc rotor
- (2) Caliper body

- (3) Hub bolt
- (4) Hub

FRONT AND REAR DISC BRAKES

Brakes

A: PAD WEAR INDICATOR

A wear indicator is provided on the inner disc brake pads. When the pad wears down to 1.5 mm (0.059 in) the tip of the wear indicator comes into contact with the disc rotor, and makes a squeaking sound as the wheel rotates. This alerts the driver to the situation.

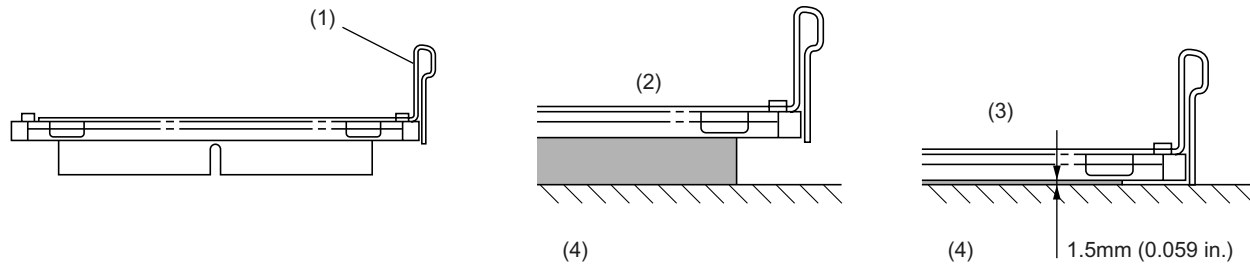

BR-00186

- (1) Wear indicator
- (2) New pad

- (3) Worn pad
- (4) Disc rotor

B: FRICTIONAL MATERIAL OF BRAKE PADS

The brake pads materials do not contain any asbestos which is harmful to human body.