

## WATER PUMP

Cooling

### 3. Water Pump

The water pump is fitted in a housing formed in the rear chain cover using an O-ring as a seal between the pump case and the housing. The pump is driven by the timing chain through a sprocket and rotation of the impeller in a volute chamber creates flow of coolant toward the cylinder block.

The pump case is made of aluminum die casting and the impeller is made of steel sheet. The impeller shaft is supported by a ball bearing and a roller bearing. Its end exposed to coolant is sealed by a mechanical seal and the other end exposed to engine oil is sealed by an oil seal.

The volute chamber is formed by the rear chain cover and the upper oil pan. A metal gasket is used at the joint between the chain cover and upper oil pan.

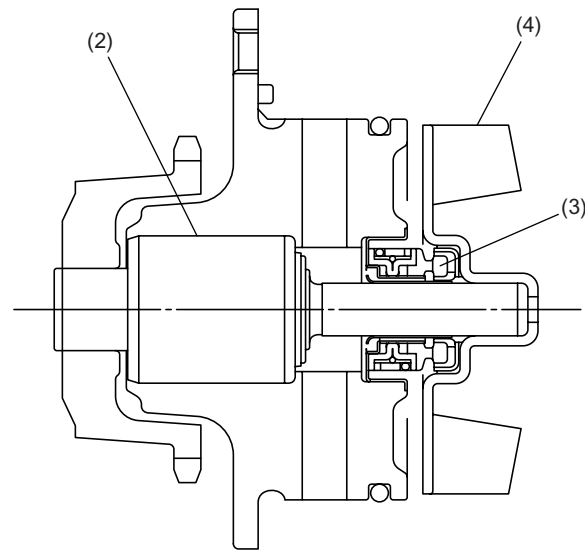
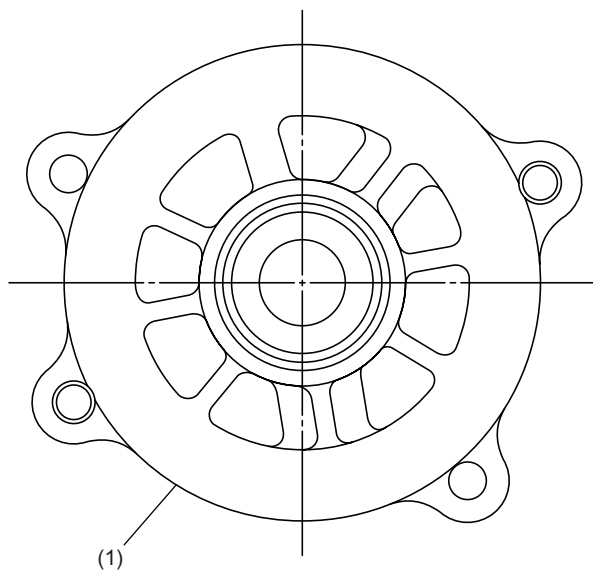

CO-00138

- (1) Pump case
- (2) Ball bearing
- (3) Mechanical seal

- (4) Impeller
- (5) O-ring