

CRUISE CONTROL

Cruise Control System

1. Cruise Control

A: OPERATION

- The cruise control system automatically controls the vehicle speed. It allows the vehicle to run at a constant speed without need for the driver to keep the accelerator pedal depressed.
- When the driver has activated the system and made a desired speed setting, the cruise control module compares the actual vehicle speed detected by the speed sensor (MT) or transmission control module (AT) with the preset speed in the memory, then generates a signal according to the difference between the two speeds. This signal is transmitted to the actuator located in the engine compartment. The actuator operates the throttle cam as necessary to keep the preset vehicle speed.

B: COMPONENT LOCATION

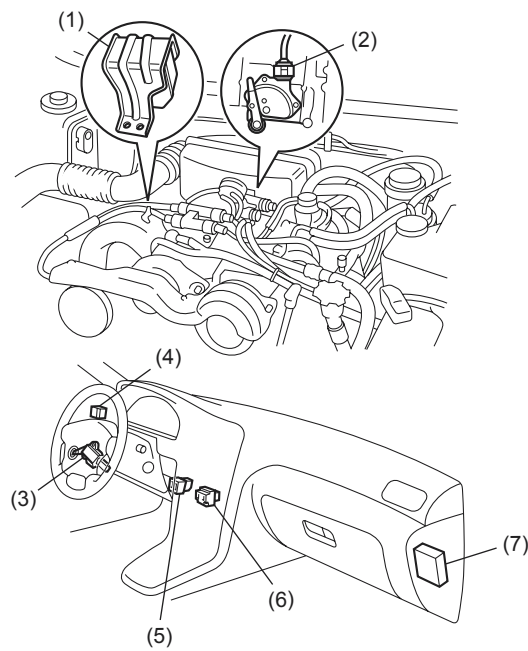

CC-00090

- | | |
|---|---------------------------|
| (1) Actuator | (5) Clutch switch (MT) |
| (2) Inhibitor switch (AT) | (6) Stop and brake switch |
| (3) Command switch (cruise control lever) | (7) Control module |
| (4) Main switch | |

CRUISE CONTROL

Cruise Control System

C: CONTROL AND OPERATION

Constant speed control	When actual vehicle speed is higher than the "set" speed, the motor in the actuator operates to move the throttle valve in the closing direction by the amount corresponding to the difference between the two speeds. When actual driving speed is lower than "set" speed, the motor operates to move the throttle valve in the opening enabling direction according to the difference in speed.
Speed setting control	When SET/COAST switch is pressed with main switch ON while the vehicle is being driven at a speed greater than 40 km/h (25 MPH), current flows to the actuator. This causes the clutch in the actuator to engage, enabling the motor to operate. The motor moves the throttle valve to the position corresponding to the accelerator pedal position. The vehicle is driven at the set speed.
Deceleration control	When SET/COAST switch is turned ON while the vehicle is cruising at a constant speed, the motor in the actuator rotates to move the throttle valve in the closing direction. This causes the vehicle to decelerate by a certain amount. When the switch is turned OFF, the vehicle speed is stored in memory and the vehicle maintains that speed thereafter.
Acceleration control	When RESUME/ACCEL switch is turned ON while the vehicle is cruising at a constant speed, the motor in the actuator rotates to move the throttle valve in the opening direction. This causes the vehicle to accelerate by a certain amount. When the switch is turned OFF, the vehicle speed is stored in memory and the vehicle maintains that speed thereafter.
Resume control	When RESUME/ACCEL switch is turned ON after the cruise control is temporarily cancelled, vehicle speed returns to that speed which was stored in memory just before the cruise control is cancelled. This occurs only when the vehicle is running at a speed greater than 32 km/h (20 MPH). In the following cases, however, the set vehicle speed is completely cleared. Therefore, no resume control is performed. (1) Ignition switch is turned OFF (2) Main switch is turned OFF
Manual cancel control	When any of the following signals is entered into the cruise control module, the clutch is disengaged and the cruise control is deactivated. (1) Stop light switch ON signal (brake pedal depressed)(2) Brake switch OFF signal (brake pedal depressed) (3) Clutch switch OFF signal (clutch pedal depressed – MT)(4) Inhibitor switch ON signal (selector lever set to "N" – AT)(5) CANCEL switch ON signal (command switch (cruise control lever) pulled)(6) Ignition switch OFF signal(7) Main switch OFF signal
Low speed limit control	When the vehicle speed drops below 32 km/h (20 MPH), the cruise control is automatically cancelled. Cruise control at any speed lower than 40 km/h (25 MPH) cannot be effected.
Motor control	When the vehicle speed becomes 10 km/h (6 MPH) or more higher than the memorized speed while vehicle is running utilizing the cruise control (in a downgrade, for example), the actuator's clutch is turned OFF so that the vehicle decelerates. When the vehicle's speed decreases by 8 km/h (5.0 MPH) or more from the memorized speed, the clutch is turned ON again so that the cruise control resumes.

CRUISE CONTROL

Cruise Control System

D: SCHEMATIC

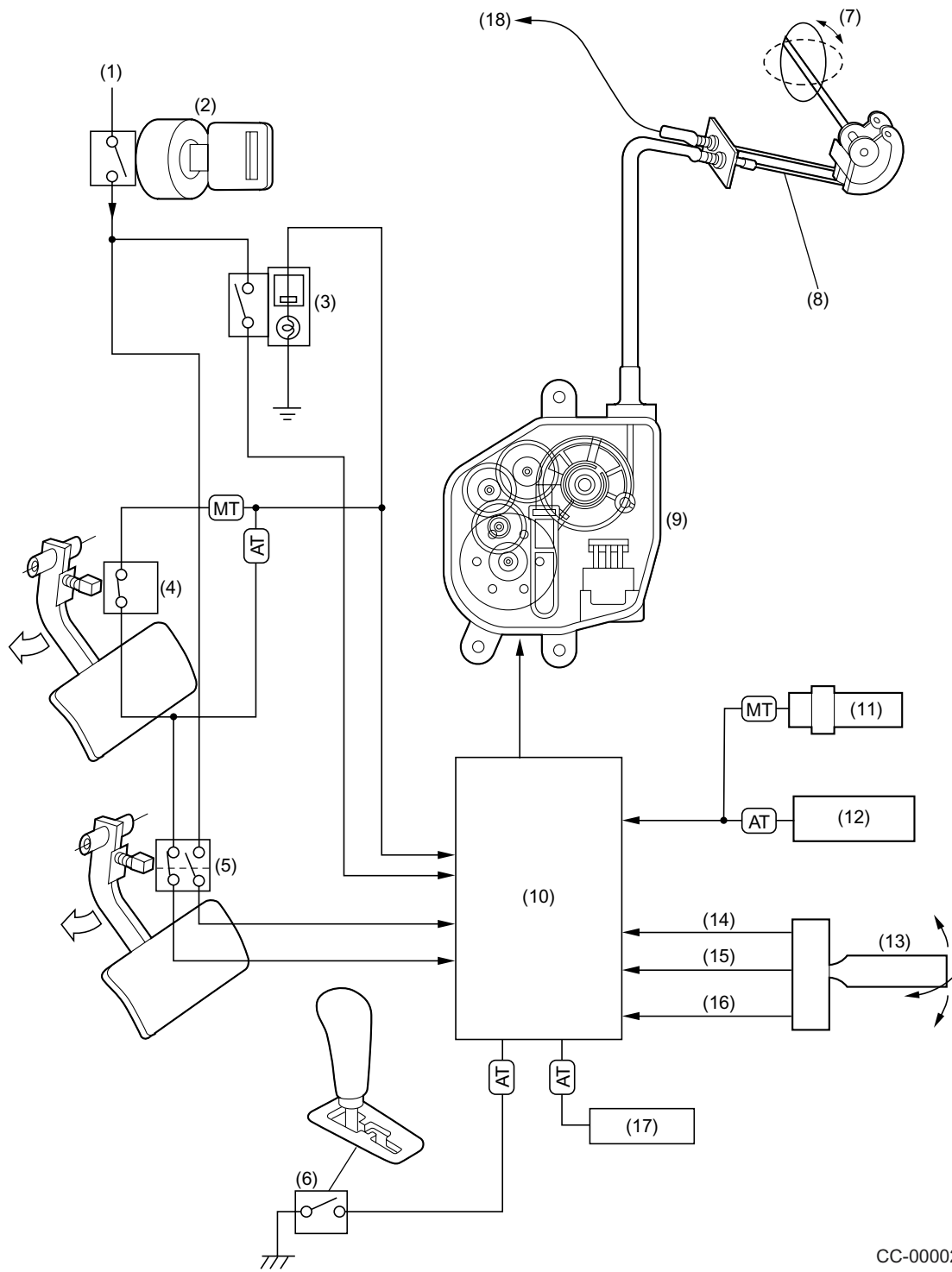

CC-00002

CRUISE CONTROL

Cruise Control System

- | | |
|---------------------------|--------------------------------|
| (1) Battery | (10) Cruise control module |
| (2) Ignition switch | (11) Vehicle speed sensor (MT) |
| (3) Main switch | (12) TCM (AT) |
| (4) Clutch switch (MT) | (13) Command switch |
| (5) Stop and brake switch | (14) RESUME/ ACCEL switch |
| (6) Inhibitor switch (AT) | (15) CANCEL switch |
| (7) Engine throttle valve | (16) SET/COAST switch |
| (8) Cruise control cable | (17) TCM (AT) |
| (9) Actuator | (18) To accelerator pedal |

CRUISE CONTROL

Cruise Control System

E: ACTUATOR

In response to a signal from the cruise control module, the clutch in the actuator is turned ON. This causes the stepping motor to operate, pulling the throttle cam for speed control.

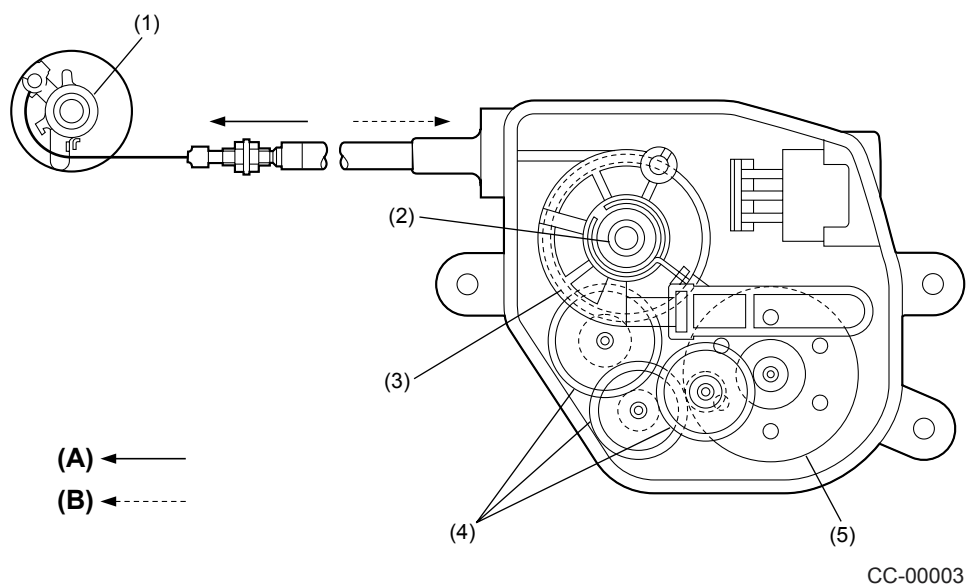

- | | | |
|------------------|--------------------|-------------|
| (1) Throttle cam | (4) Gear | (A) Release |
| (2) Clutch | (5) Stepping motor | (B) Pull |
| (3) Pulley | | |

F: MAIN SWITCH

- The main switch is the main power supply switch of the cruise control module. It has a built-in power indicator (A) and a night illumination light (B).
- When the ignition switch is placed in the OFF position with the main switch ON, the main switch is also turned OFF. Even if the ignition switch is turned ON again, the main switch will stay in the OFF state.

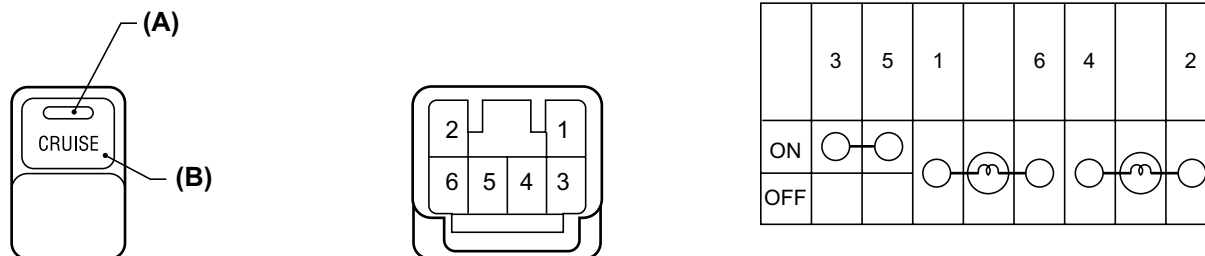

CC-00091

G: COMMAND SWITCH (CRUISE CONTROL LEVER)

- When the vehicle is driven with the cruise control activated, the command switch controls its operation. It inputs SET/COAST signal, RESUME/ACCEL signal or CANCEL signal to the cruise control module.

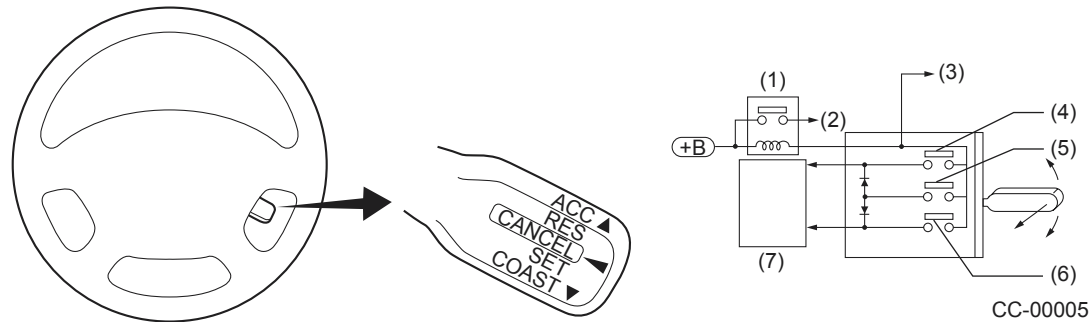

- | | |
|-----------------|--------------------|
| (1) Horn relay | (5) CANCEL |
| (2) Horn | (6) RESUME/ ACCEL |
| (3) Horn switch | (7) Control module |
| (4) SET/COAST | |

- The command switch is located on the right side of the steering wheel, so the driver can operate it without releasing hands from the steering wheel.
- The command switch is a self-returning lever type.

1. RESUME/ACCEL AND SET/COAST SWITCH

Each switch contact is held closed as long as the lever is kept pressed in the relevant direction and resulting current is applied as a signal to the control module.

2. CANCEL SWITCH

All the switch contacts are closed as long as the lever is pulled toward the CANCEL position (toward the driver). This causes the RESUME/ACCEL and SET/COAST ON signals to be sent to the control module simultaneously.

CRUISE CONTROL

Cruise Control System

H: CANCEL SIGNALS

The cancel signal deactivates the cruise control function. Operating any of the following switches results in generation of the cancel signal. On receiving the signal, the cruise control module cancels the cruise control function.

- Stop light switch
- Brake switch
- Clutch switch (MT model)
- Inhibitor switch (AT model)
- Main switch
- Command switch (CANCEL position)

I: VEHICLE SPEED SENSOR

Vehicle speed sensor is installed on the transmission, and sends signal to the cruise control module which uses it in controlling the cruise control function (MT model).

J: ENGINE THROTTLE

- The throttle body is equipped with two throttle cams. One is used during acceleration and the other during cruising in order to open or close the throttle valve.
- These cams operate independently of each other. In other words, when one cam operates, the other may not.

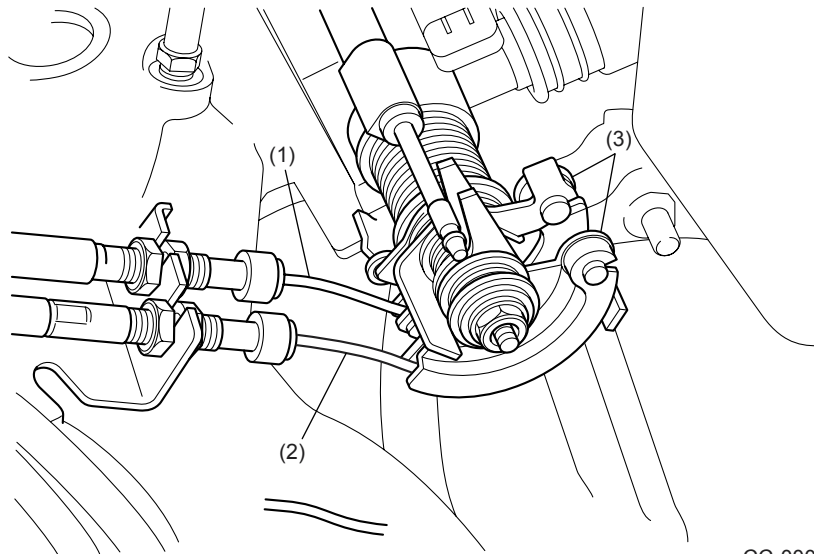

CC-00092

- (1) Accelerator cable
- (2) Cruise control cable
- (3) Throttle cam

CRUISE CONTROL

Cruise Control System

K: CONTROL MODULE

- Based on signals from the related switches and sensors, the cruise control module controls all the following control functions:

Constant speed control; speed setting control; deceleration control; acceleration control; resume control; manual cancel control; low speed limit control; stepping motor control; cruise control

- The control module (A) is located inside of the front pillar lower portion (passenger side).

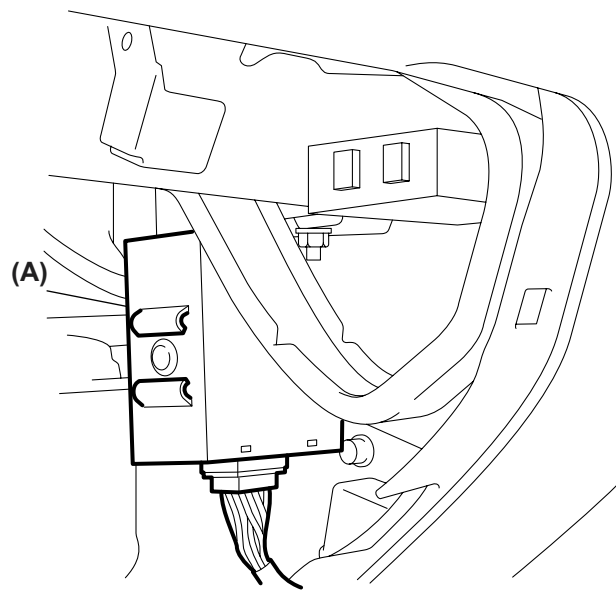

CC-00093

CRUISE CONTROL

Cruise Control System

L: FAIL-SAFE FUNCTION

The cruise control system has a fail-safe function that cancels the cruise control operation when any of the following conditions occurs.

1. CONFLICT BETWEEN CRUISE CONTROL SWITCHES AND CANCELLATION SIGNAL GENERATING SWITCHES

1) The cruise control system is deactivated if any of the cruise control switches (SET/COAST, RESUME/ACCEL, and CANCEL switches) is turned ON while any of the cancellation signal generating switches (brake, stop lamp, clutch, and inhibitor switches) is being operated. The system is re-activated when the cruise control switch is turned OFF and then turned ON again after the cancellation signal generating switch has been returned to its released position.

2) The cruise control system becomes deactivated if the ignition switch is turned ON with any of the cruise control switches in the ON position. The system deactivating function is retained until the ignition switch is turned OFF.

2. ABNORMALITIES IN ELECTRIC CIRCUITS

The cruise control system is deactivated and the set speed is also canceled if any of the following abnormalities occurs in the system's electric circuits.

The system deactivation function is retained until the ignition switch or the main switch is turned OFF.

1) The stepping motor terminal is grounded or disconnected; or the stepping motor drive circuit is broken due to a short-circuit.

2) The stepping motor clutch drive circuit is shorted.

3) Vehicle speed variation in a 350 ms period exceeds $\pm 10\text{km/h}$ ($\pm 16\text{ MPH}$).

4) Fusion has occurred in an internal relay and is detected while the vehicle is running with the cruise control deactivated.

5) The cruise control module becomes inoperative or its operation is faulty.

6) There is discrepancy between the values stored in the two RAMs of the control module.

7) An abnormality is detected as a result of the self-diagnosis performed after turning ON of the ignition switch.

3. ABNORMALITIES IN STEPPING MOTOR

The cruise control system is deactivated if either of the following abnormalities occurs in the stepping motor.

1) The stepping motor does not operate properly.

2) The stepping motor is energized for unduly long period and too frequently.

When the system is deactivated by any of these causes, it cannot be reactivated for 2 – 20 minutes after detection of the abnormal condition.