

## FRONT SUSPENSION

Front Suspension

---

### 1. Front Suspension

#### A: GENERAL

The front suspension is a strut-type independent suspension, with cylindrical double-acting, oil-filled dampers and coil springs. The top of each strut assembly is attached to the body through a rubber cushion. Used in combination with other rubber cushions, this rubber cushion effectively insulate vibration and shock and thus improves ride comfort. This type also maintains a wide distance between the upper and lower supporting points and makes adjustment of the caster unnecessary.

The transverse link is an "L" shaped arm design to increase steering stability and reduce road noise. The transverse link has a maintenance-free ball joint fitted by a castle nut at its outer end. The front of the link's inner end is fitted to the front crossmember through a rubber cushion and the rear of the inner end is bolted to the vehicle body through a fluid-filled bushing.

The front crossmember is bolted to the vehicle body.

The stabilizer is attached to the front crossmember through rubber cushions and its right and left ends are connected to the stabilizer links through rubber bushings.

The lower end of the stabilizer link is connected to the transverse link through rubber bushings.

A camber angle adjustment mechanism, which uses eccentric bolts, is provided at the joint of the damper strut and axle housing.

# FRONT SUSPENSION

Front Suspension

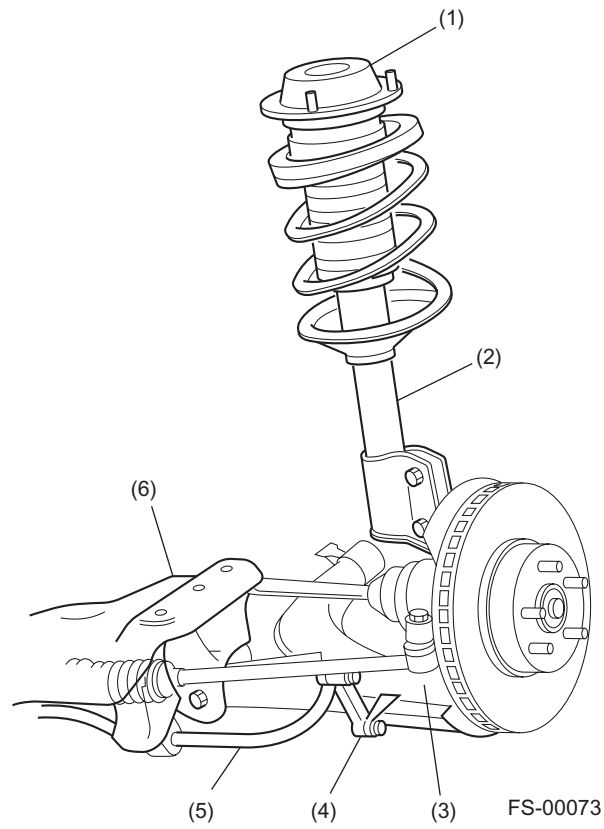

- (1) Strut mount
- (2) Strut
- (3) Transverse link

- (4) Stabilizer link
- (5) Stabilizer
- (6) Front crossmember

## FRONT SUSPENSION

Front Suspension

---

**MEMO**