

5. Control System

A: GENERAL

The ECM receives signals from various sensors, switches, and other control modules. Using these signals, it determines the engine operating conditions and if necessary, emits signals to one or more systems to control them for optimum operation.

Major control items of the ECM are as follow:

- Fuel injection control
- Ignition control
- Idle air control
- Canister purge control*¹
- Radiator fan control*²
- Fuel pump control
- On-board diagnosis function

*1: Canister purge control is described under “EC (H6) Emission Control (Aux. Emission Control Devices) Evaporative Emission Control System”.

*2: Radiator fan control is described under “CO (H6) Cooling”.

CONTROL SYSTEM

Fuel Injection (Fuel System)

B: INPUT AND OUTPUT SIGNALS

Signal	Unit	Function
Input signals	Intake manifold pressure sensor	Detects the amount of intake air (measures the absolute pressure).
	Intake air temperature sensor	Detects the temperature of intake air.
	Throttle position sensor	Detects the throttle valve position.
	Front oxygen (A/F) sensor	Detects the density of oxygen in exhaust gases at the upstream of the front catalytic converter.
	Rear oxygen sensor	Detects the density of oxygen in exhaust gases at the downstream of the rear catalytic converter.
	Crankshaft position sensor	Detects the crankshaft angular position.
	Camshaft position sensor	Detects the combustion cylinder.
	Engine coolant temperature sensor	Detects the engine coolant temperature.
	Knock sensor	Detects engine knocking.
	Front vehicle speed sensor	Detects the vehicle speed.
	Ignition switch	Detects operation of the ignition switch.
	Starter switch	Detects the condition of engine cranking.
	Inhibitor switch	Detects shift positions.
	Diagnostic of AT	Detects the self-diagnostics of AT
	Heater circuit of front and rear oxygen sensors	Detects abnormality in the heater circuit of the front and rear oxygen sensors.
	A/C switch	Detects ON-OFF operation of the A/C switch.
	Fuel temperature sensor	Detects the temperature of the fuel in the fuel tank.
	Fuel level sensor	Detects the level of the fuel in the fuel tank.
	Fuel tank pressure sensor	Detects the evaporation gas pressure in the fuel tank.
	Small light switch	Detects ON-OFF operation of the small light switch.
Blower fan switch	Detects ON-OFF operation of the blower fan switch.	
Rear defogger switch	Detects ON-OFF operation of the rear defogger switch.	
Output signals	Fuel Injector	Activates an injector.
	Ignition signal	Turns the primary ignition coil current ON or OFF.
	Fuel pump relay	Turns the fuel pump relay ON or OFF.
	Fuel pump controller	Controls the voltage supplied to the fuel pump.
	A/C control relay	Turns the A/C control relay ON or OFF.
	Radiator fan control relay	Turns the radiator fan control relay ON or OFF.
	Idle air control solenoid valve	Adjusts the amount of air flowing through the bypass line in the throttle body.
	Induction control solenoid valve	Controls induction control valve.
	EGR solenoid valve	Controls EGR valve.
	Malfunction indicator lamp	Indicates existence of abnormality.
	Purge control solenoid valve	Controls purge of evaporative gas absorbed by the canister.
	Power supply	Controls ON/OFF of the main power supply relay.
	Pressure control solenoid valve	Controls evaporation pressure in fuel tank.
	Drain valve	Closes the evaporation line between the fuel tank and canister to detect leakage of evaporation gases.

C: FUEL INJECTION CONTROL

- The ECM receives signals from various sensors and based on them, it determines the amount of fuel injected and the fuel injection timing. It performs the sequential fuel injection control over the entire engine operating range except during start-up of the engine.
- The amount of fuel injected depends upon the length of time the injector stays open. The fuel injection duration is determined according to varying operating condition of the engine. For the purpose of achieving highly responsive and accurate fuel injection duration control, the ECM performs a new feedback control that incorporates a learning feature as detailed later.
- The sequential fuel injection control is performed such that fuel is injected accurately at the time when the maximum air intake efficiency can be achieved for each cylinder (i.e., fuel injection is completed just before the intake valve begins to open).

1. FUEL INJECTION DURATION

Fuel injection duration is basically determined as indicated below:

- During engine start-up:

The duration defined below is used.

- Duration of fuel injection during engine start-up Determined according to the engine coolant temperature detected by the engine coolant temperature sensor.

- During normal operation:

The duration is determined as follows:

Basic duration of fuel injection × Correction factors + Voltage correction time

- Basic duration of fuel injection The basic length of time fuel is injected. This is determined by two factors the amount of intake air detected by the manifold pressure sensor and the engine speed monitored by the crankshaft position sensor.
- Correction factors See the next section.
- Voltage correction time This is added to compensate for the time lag before operation of injector that results from variation in the battery voltage.

CONTROL SYSTEM

Fuel Injection (Fuel System)

2. CORRECTION FACTORS

The following factors are used to correct the basic duration of fuel injection in order to make the air-fuel ratio meet the requirements of varying engine operating conditions:

- Air-fuel ratio feedback factor:

This factor is used to correct the basic duration of fuel injection in relation to the actual engine speed. (See the next section for more details.)

- Start increment factor:

This factor is used to increase the fuel injection duration only while the engine is being cranked to improve its startability.

- Coolant-temperature-dependent increment factor:

This factor is used to increase the fuel injection duration depending on engine coolant temperature signals to facilitate cold starting. The lower the coolant temperature, the greater the increment.

- After-start increment factor:

- This factor is used to increase the fuel injection duration for a certain period immediately after start of the engine to stabilize engine operation.

- The increment depends on the coolant temperature at the start of the engine.

- Wide-open-throttle increment factor:

This factor is used to increase the fuel injection duration depending on the relationship between the throttle position sensor signal and manifold pressure sensor signal.

- Acceleration increment factor:

This factor is used to increase the fuel injection duration to compensate for a time lag between air flow measurement and fuel injection control for better engine response to driver's pedal operation during acceleration.

CONTROL SYSTEM

Fuel Injection (Fuel System)

3. AIR-FUEL RATIO FEEDBACK FACTOR

The ECM creates this factor utilizing the front oxygen (A/F) sensor signal. When the signal current is low, the air-fuel ratio is richer than the stoichiometric ratio. The ECM then makes the fuel injection duration shorter by modifying the factor. When the current is high showing that the mixture is lean, the ECM modifies the factor to make the injection duration longer. In this way, the air-fuel ratio is maintained at a level close to the stoichiometric ratio at which the three-way catalyst acts most effectively.

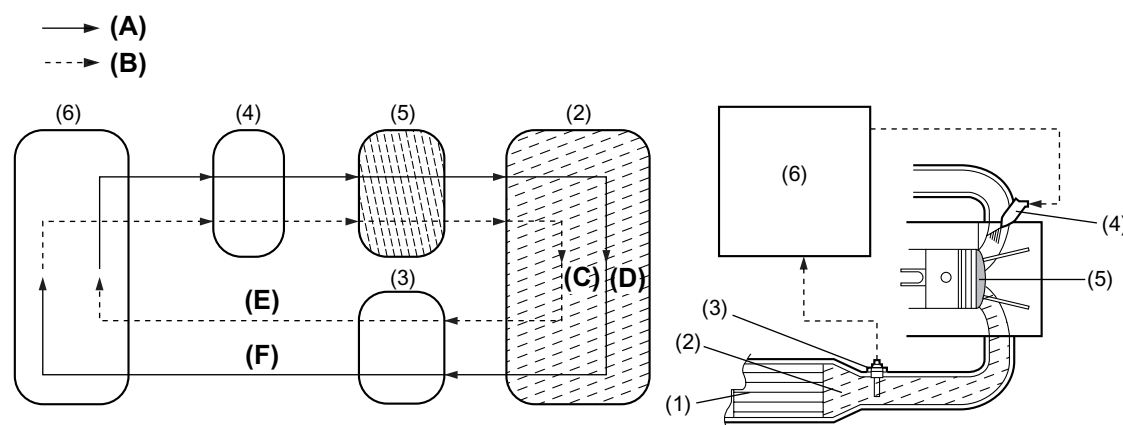

FU-00240

- (1) Front catalyst
- (2) Exhaust gas
- (3) Front oxygen (A/F) sensor
- (4) Fuel Injector
- (5) Combustion chamber
- (6) ECM

- (A) Injection duration increment signal
- (B) Injection duration decrement signal
- (C) High oxygen density
- (D) Low oxygen density
- (E) Lean signal
- (F) Rich signal

4. LEARNING FEATURE

The air-fuel ratio feedback control includes a learning feature which contributes to more accurate and responsive control.

- In the air-fuel ratio feedback control, the ECM calculates the necessary amount of correction based on data from the oxygen sensor and adds the result to the basic duration (which is stored in the ECM's memory for each condition defined by the engine speed and various loads.)
- Without a learning feature, the ECM carries out the above-mentioned process every time. This means that if the amount of necessary correction is large, the air-fuel ratio feedback control becomes less responsive and less accurate.
- The learning feature enables the ECM to store the amount of correction into memory and add it to the basic fuel injection duration to create a new reference fuel injection duration. Using the reference duration as the basic duration for the injection a few times later, the ECM can reduce the amount of correction and thus make its feedback control more accurate and responsive to changes in the air-fuel ratio due to difference in driving condition and sensor/actuator characteristics that may result from unit-to-unit variation or aging over time.

CONTROL SYSTEM

Fuel Injection (Fuel System)

D: IGNITION CONTROL SYSTEM

- The ECM determines operating condition of the engine based on signals from the pressure sensor, engine coolant temperature sensor, intake air temperature sensor, crankshaft position sensor and other sources. It then selects the ignition timing most appropriate for the condition thus determined from those stored in its memory and outputs at that timing a primary current OFF signal to the ignitor to initiate ignition.
- This control uses a quick-to-response learning feature by which the data stored in the ECM memory is processed in comparison with information from various sensors and switches.
- Thus, the ECM can always perform optimum ignition timing taking into account the output, fuel consumption, exhaust gas, and other factors for every engine operating condition.
- Ignition control during start-up
Engine speed fluctuates during start of the engine, so the ECM cannot control the ignition timing. During that period, the ignition timing is fixed at 10° BTDC by using the 10° signal from the crankshaft position sensor.

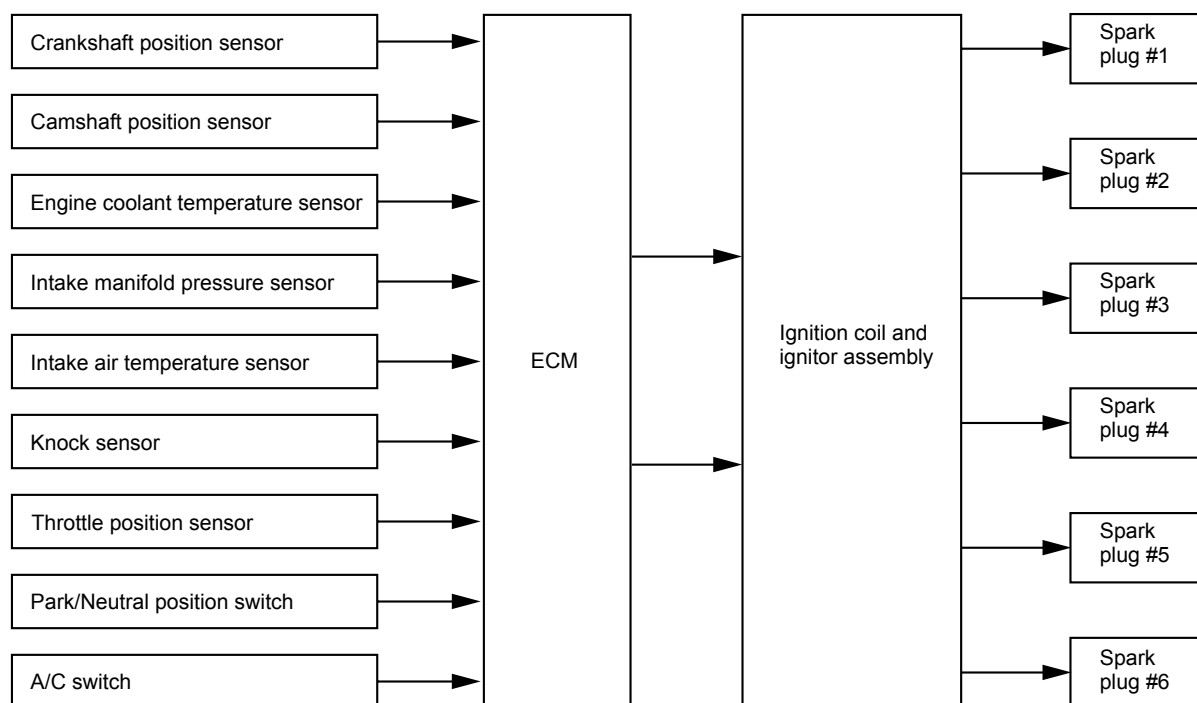

FU-00612

CONTROL SYSTEM

Fuel Injection (Fuel System)

- The ECM receives two types of crank angle signal pulse; one is generated every 10× of crankshaft rotation and the other, every 30× of crankshaft rotation. Using these two types of signal pulse, the ECM determines the position of each piston as follows:

The ECM interprets the pulses of range (A) shown below as the No. 1 and No. 2 cylinder pistons being at TDC, the pulses of range (B) as the No. 5 and No. 6 cylinder pistons being at TDC, and the pulses of range (C) as the No. 3 and No. 4 cylinder pistons being at TDC.

- The ECM outputs an ignition signal for the No. 1, No. 3 or No. 5 cylinder when it receives a camshaft angle pulse before a TDC signal and for the No. 2, No. 4 or No. 6 cylinder when it receives no camshaft angle pulse before a TDC signal.

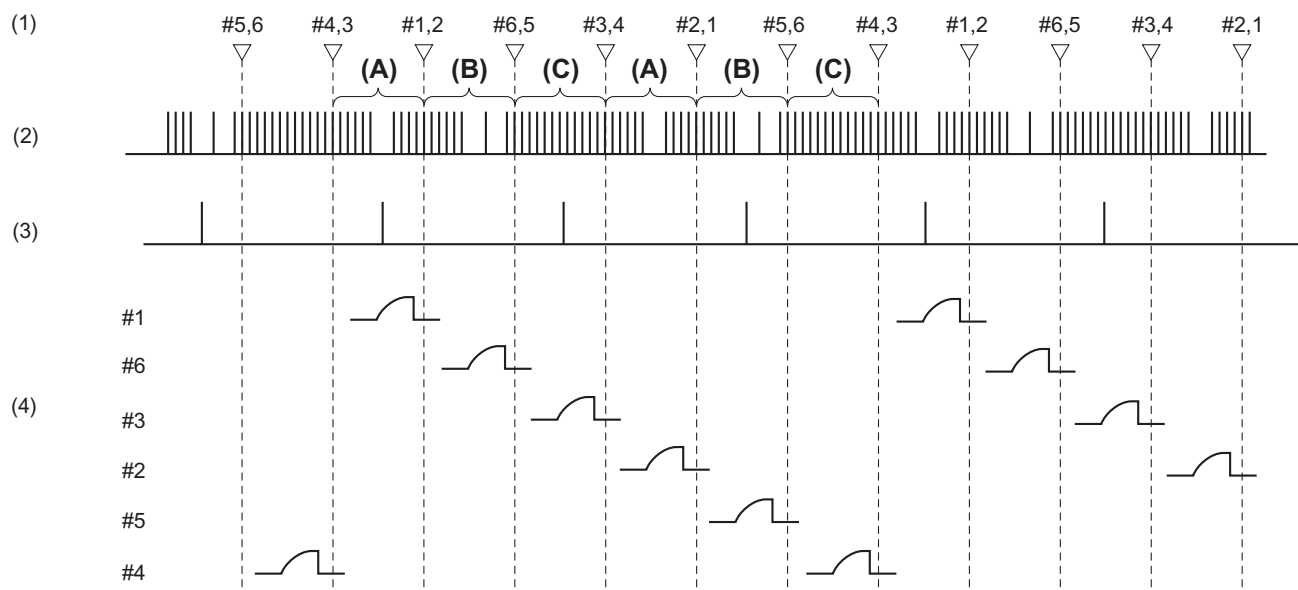

FU-00613

- (1) Cylinder number (TDC)
- (2) Crank angle pulse
- (3) Cam angle pulse
- (4) Ignition timing

CONTROL SYSTEM

Fuel Injection (Fuel System)

E: IDLE AIR CONTROL

- The ECM activates the idle air control solenoid valve to control the bypass air flowing through the bypass passage in the throttle body depending on signals from the crankshaft position sensor, engine coolant temperature sensor, pressure sensor and A/C switch so that the proper idle speed for each engine load is achieved.
- The idle air control solenoid valve uses a duty-ratio-controlled solenoid which can continuously vary the opening area of the rotary valve. As the ECM increases the duty ratio, opening of the rotary valve increases so that the bypass air flow increases, and the engine idling speed becomes higher as a result.
- The bypass air control is necessary for:
 - Increasing idling speed when the air conditioning system and/or electrical loads are turned on.
 - Increasing idling speed during early stage of warm up period.
 - Obtaining dashpot function when the throttle valve is quickly closed.
 - Prevention of engine speed variation during idling.

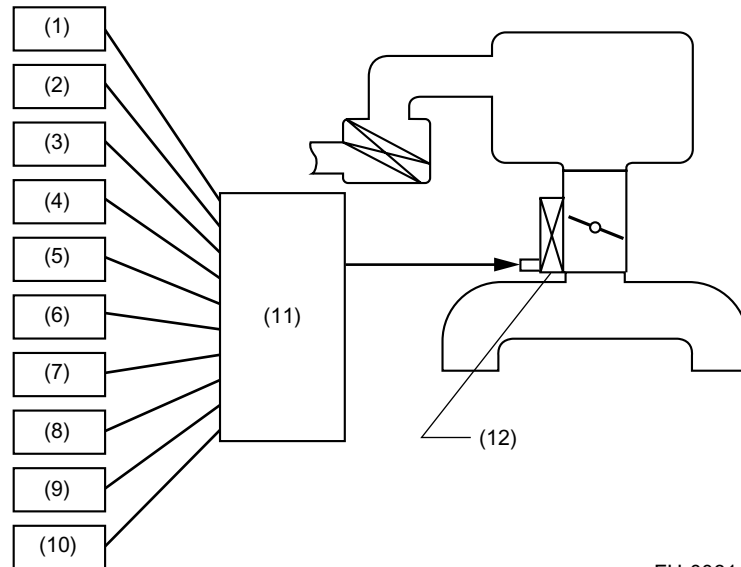

FU-00614

- | | |
|---------------------------------------|--------------------------------------|
| (1) Intake manifold pressure sensor | (7) Front vehicle speed sensor |
| (2) Intake air temperature sensor | (8) Ignition switch |
| (3) Crankshaft position sensor | (9) A/C switch |
| (4) Camshaft position sensor | (10) Inhibitor switch |
| (5) Throttle position sensor | (11) ECM |
| (6) Engine coolant temperature sensor | (12) Idle air control solenoid valve |

CONTROL SYSTEM

Fuel Injection (Fuel System)

F: FUEL PUMP CONTROL

- Using the signal from the crankshaft position sensor, the ECM controls operation of the fuel pump by turning its relay ON or OFF. To improve safety, the fuel pump is stopped if the engine stalls with the ignition switch ON.

Ignition switch ON	Fuel pump relay	Fuel pump
A certain period of time after ignition switch is turned ON	ON	Operates
While cranking the engine	ON	Operates
While engine is operating	ON	Operates
When engine stops	OFF	Does not operate

- Also, by controlling the voltage supplied to the fuel pump with the fuel pump controller, the fuel temperature is lowered and fuel consumption is reduced.