

IGNITION COIL

Ignition

1. Ignition Coil

The engine uses a direct ignition system with one ignition coil mounted for each cylinder (or spark plug).

The secondary terminal of the ignition coil is in contact with the spark plug terminal nut.

Since no spark plug cable is used, secondary voltage drop, leaks, or other problems that are inherent in a system using spark plug cables do not occur. The result is high performance and high reliability.

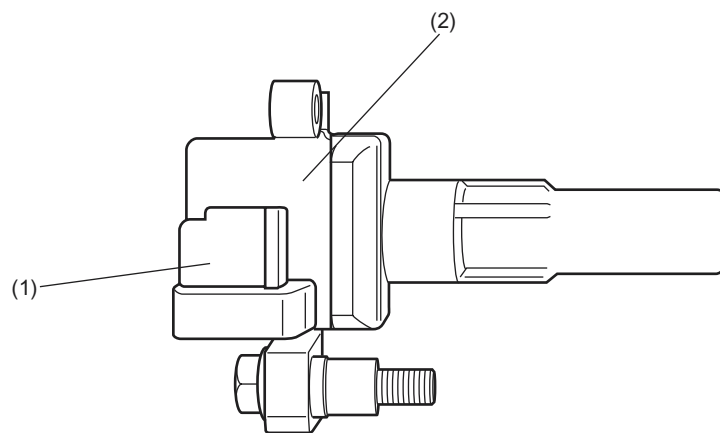

IG-00066

- (1) Connector
- (2) Ignition coil