

CYLINDER BLOCK

Mechanical

7. Cylinder Block

- The cylinder block of this horizontally-opposed-cylinder engine is made of aluminum die casting. It is split into right and left halves at its center where the crankshaft is supported. The cylinder liners are made of cast iron and are embedded as integral part of the cylinder block body during the casting process.
- The coolant passages of the right and left banks are independent of each other (parallel-flow type). The water jackets around the cylinder liners are open at the cylinder head side end of each bank (open-deck design).
- The cylinder block supports the crankshafts journals through seven main bearings rigidly and quietly. The #7 bearing is a flanged thrust bearing which controls the crankshafts end play.
- Rigid engine-to-transmission connection is ensured by 11 bolts (three more bolts than with the four-cylinder engine).
- The aluminum die-cast upper oil pan located below the cylinder block reinforces connection between the cylinder block banks and its special form provides a baffle effect to suppress large fluctuation of oil level. In addition, the upper oil pan constitutes part of the oil and cooling circuits as well as the water pump volute chamber and thermostat chamber.

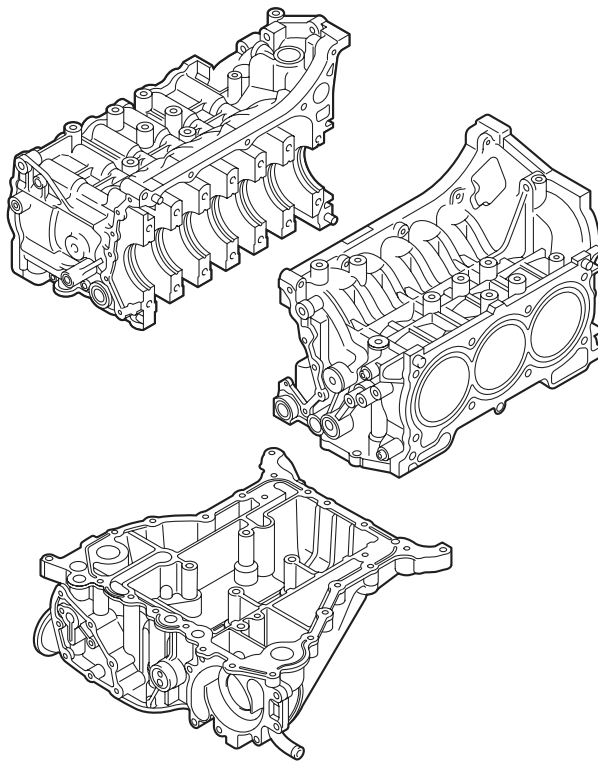

ME-00613