

# PISTON

Mechanical

## 9. Piston

- The pistons are of a slipper skirt design for reduced weight and friction. The oil control ring groove utilizes a thermal design.
- The piston pin is offset either downward (Nos. 1, 3 and 5 pistons) or upward (Nos. 2, 4 and 6 pistons).
- The piston crown is spherically concaved and has no recesses for valve head clearance. All the right and left bank pistons are the same in shape. Each piston has a location mark (mark indicating the front of engine) on its top.
- Three piston rings are used for each piston; two compression rings and one oil control ring. The top piston ring has inner bevels and the second piston ring has an interrupt (cut) on the bottom outside to reduce oil consumption.

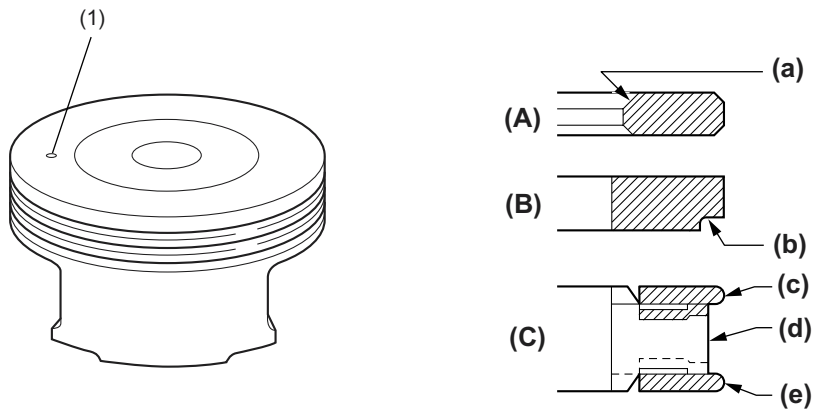

ME-00615

(1) Location mark (engine front side)

(A) Top ring  
(B) Second ring  
(C) Oil ring

(a) Inner-bevel  
(b) Cut  
(c) Upper rail  
(d) Expander  
(e) Lower rail