

GENERAL

Speed Control System

1. General

The accelerator outer cable is secured to the accelerator pedal bracket rather than to the toeboard. Securing the outer cable in this way has a merit of making the ratio of throttle valve movement to cable stroke less variable. This arrangement is also effective to prevent unsmooth cable return movement that may result from deformation of the toeboard or improper installation of the accelerator pedal and, therefore, to improve safety.

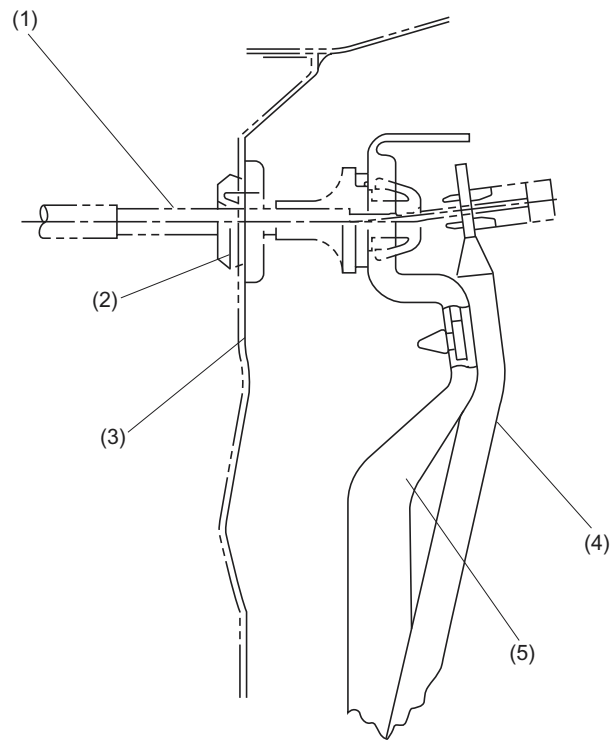

SP-00020

- (1) Accelerator cable
- (2) Grommet
- (3) Toeboard
- (4) Accelerator pedal
- (5) Bracket