

AT OIL TEMP WARNING LIGHT DISPLAY

AUTOMATIC TRANSMISSION (DIAGNOSTICS)

10.AT OIL TEMP Warning Light Display

A: INSPECTION

When any on-board diagnostics item is malfunctioning, the display on the AT OIL TEMP warning light blinks from the time the malfunction is detected after starting the engine until the ignition switch is turned OFF. The malfunctioning part or unit can be determined by a DTC during on-board diagnostics operation. Problems which occurred previously can also be identified through the memory function. If the AT OIL TEMP warning light does not show a problem (although a problem is occurring), the problem can be determined by checking the performance characteristics of each sensor using the select monitor. Indicator signal is as shown in the figure.

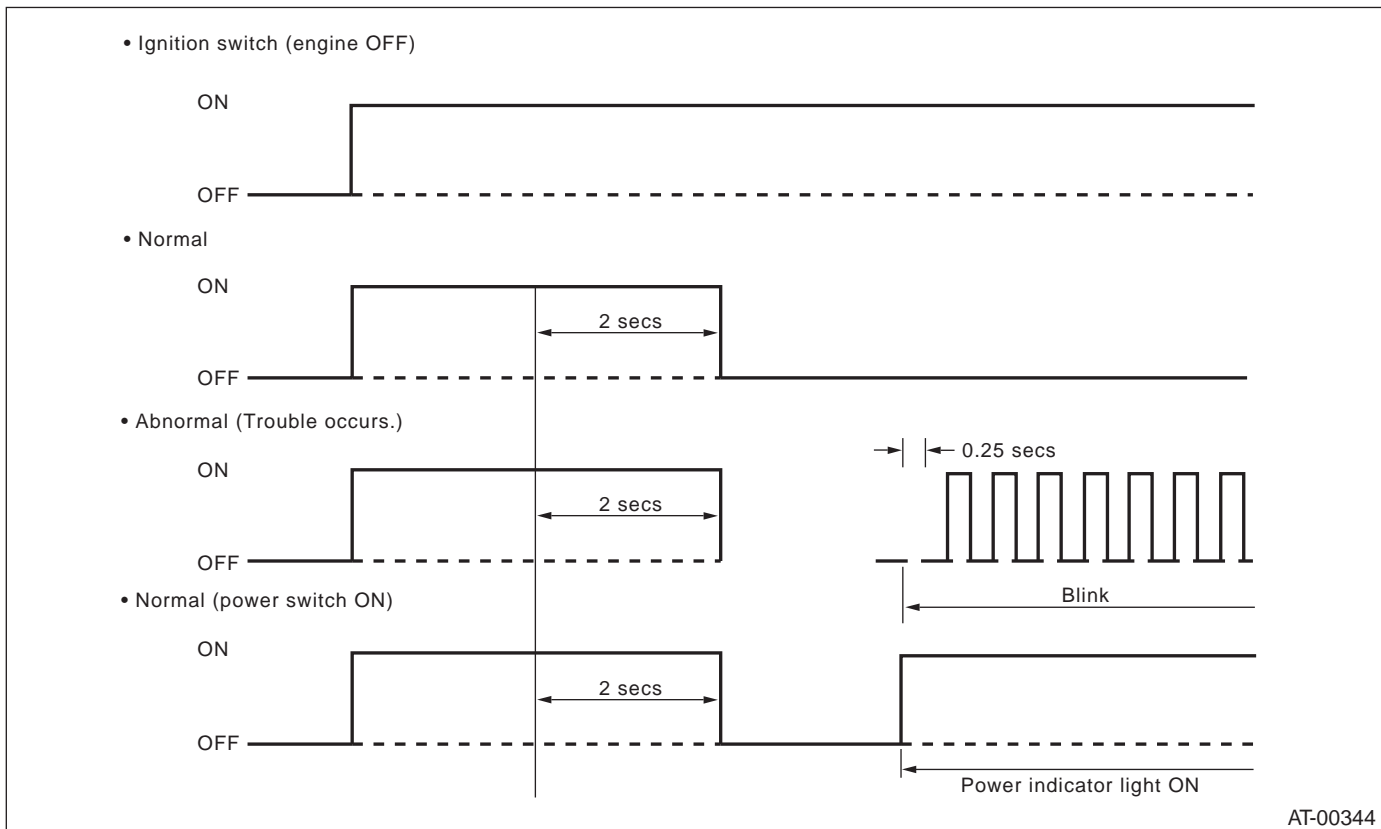

AT-30