

## TRANSMISSION CASE

### MANUAL TRANSMISSION AND DIFFERENTIAL

## 14. Transmission Case

### A: REMOVAL

- 1) Remove the manual transmission assembly from vehicle. <Ref. to MT-26, REMOVAL, Manual Transmission Assembly.>
- 2) Remove clutch release lever. <Ref. to CL-13, REMOVAL, Release Bearing and Lever.>
- 3) Remove transfer case with extension case assembly. <Ref. to MT-38, REMOVAL, Transfer Case and Extension Case Assembly.>
- 4) Remove bearing mounting bolts.

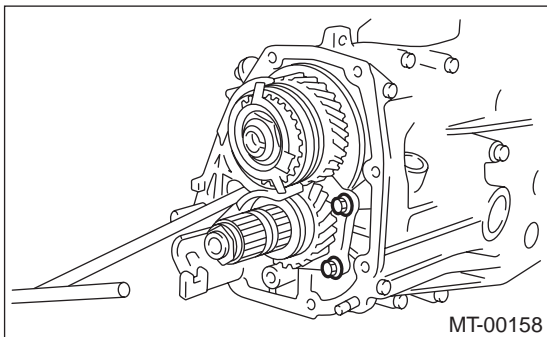

- 5) Remove main shaft rear plate.

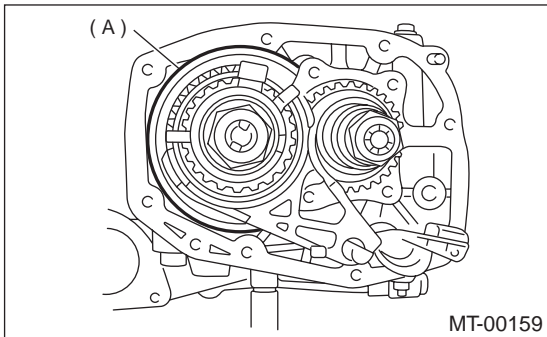

(A) Main shaft rear plate

- 6) Put vinyl tape around splines of right and left axle drive shafts to prevent damage to oil seal.

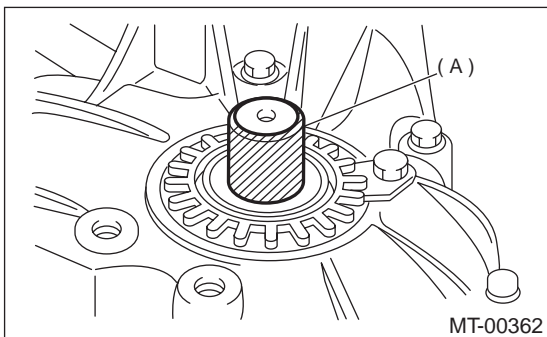

(A) Vinyl tape

- 7) Separate transmission case into right and left cases by loosening coupling bolts and nuts.

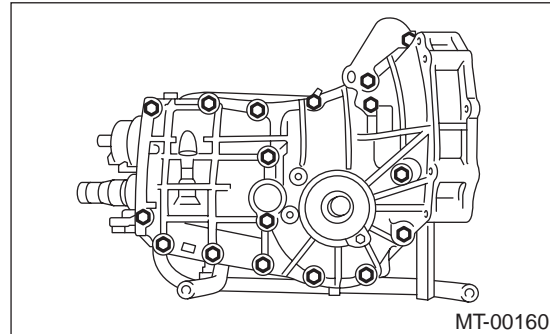

- 8) Remove drive pinion shaft assembly from left side transmission case.

#### NOTE:

Use a hammer handle, etc. to remove if too tight.

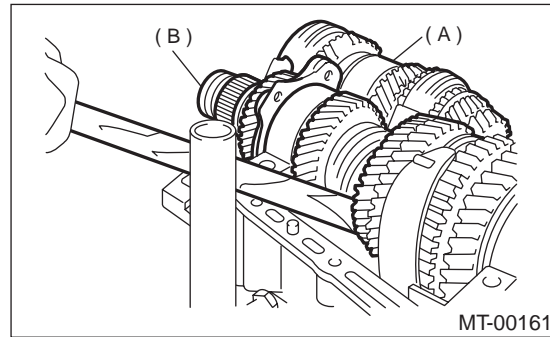

- (A) Main shaft assembly  
(B) Drive pinion shaft assembly

- 9) Remove main shaft assembly.
- 10) Remove differential assembly.

#### NOTE:

- Be careful not to confuse right and left roller bearing outer races.
- Be careful not to damage retainer oil seal.

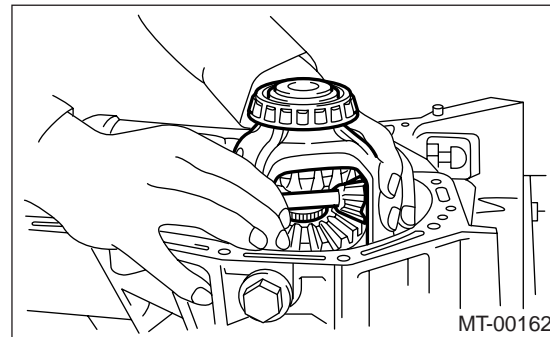

MT-50

## TRANSMISSION CASE

MANUAL TRANSMISSION AND DIFFERENTIAL

### B: INSTALLATION

- 1) Wipe off grease, oil and dust on the mating surfaces of transmission cases with white gasoline.
- 2) Install the front differential assembly.
- 3) Install the main shaft assembly.  
Install needle bearing knock pin hole into transmission case knock pin.
- 4) Install the drive pinion shaft assembly.  
Install roller bearing knock pin hole into transmission case knock pin.
- 5) Apply liquid gasket, and then put case right side and left side together.

#### Liquid gasket:

**THREE BOND 1215 (Part No. 004403007) or equivalent**

- 6) Tighten 17 bolts with bracket, clip, etc. as shown in the figure.

#### NOTE:

- Insert bolts from the bottom and tighten nuts at the top.
- Put cases together so that drive pinion shim and input shaft holder shim are not caught up in between.
- Confirm that speedometer gear is meshed.

#### Tightening torque:

**8 mm bolt**

**25 N·m (2.5 kgf-m, 18.1 ft-lb)**

**★ 10 mm bolt**

**39 N·m (4.0 kgf-m, 28.9 ft-lb)**

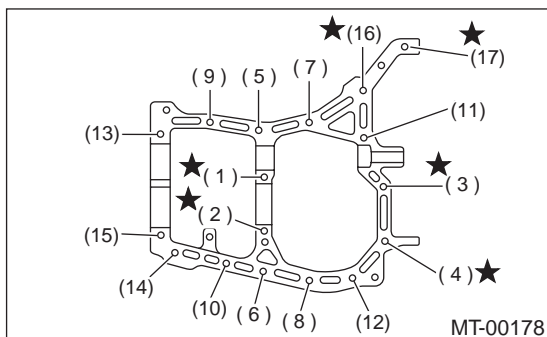

- 7) Tighten ball bearing attachment bolts.

#### Tightening torque:

**30 N·m (3.1 kgf-m, 22.4 ft-lb)**

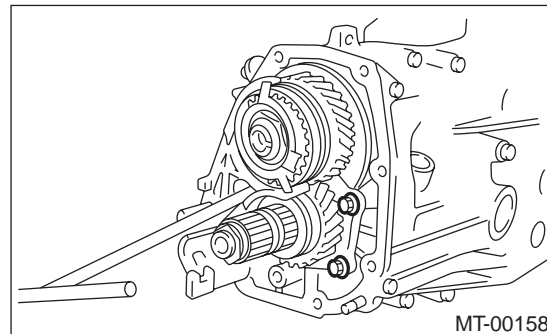

- 8) Backlash adjustment of hypoid gear and preload adjustment of roller bearing

#### NOTE:

Support drive pinion assembly with ST.

ST 498427100 STOPPER

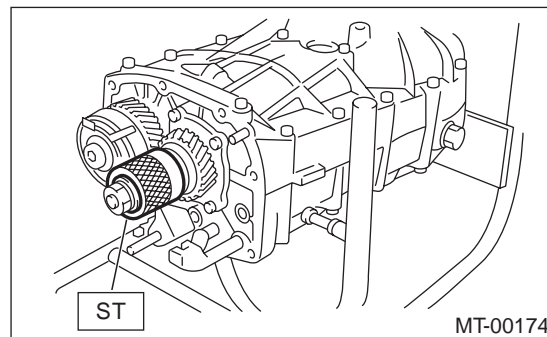

- 9) Place the transmission with case left side facing downward and put ST1 on bearing cup.

10) Screw retainer assembly into left case from the bottom with ST2. Fit ST3 on the transmission main shaft. Shift gear into 4th or 5th and turn the shaft several times. Screw in the retainer while turning ST3 until a slight resistance is felt on ST2. This is the contact point of hypoid gear and drive pinion shaft. Repeat the above sequence several times to ensure the contact point.

ST1 399780104 WEIGHT

ST2 499787000 WRENCH ASSY

ST3 499927100 HANDLE

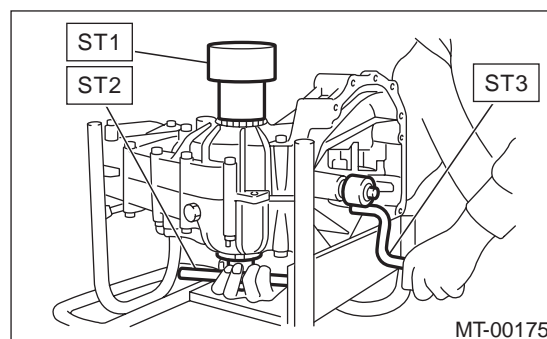

MT-51

## TRANSMISSION CASE

### MANUAL TRANSMISSION AND DIFFERENTIAL

11) Remove weight and screw in retainer without O-ring on the upper side and stop at the point where slight resistance is felt.

**NOTE:**

At this point, the backlash between the hypoid gear and drive pinion shaft is zero.

ST 499787000 WRENCH ASSY

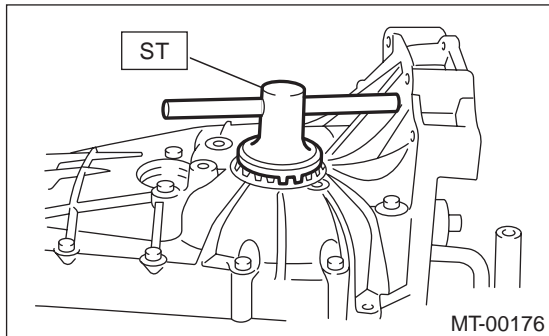

12) Fit lock plate. Loosen the retainer on the lower side by 1-1/2 notches of lock plate and turn in the retainer on the upper side by the same amount in order to obtain the backlash.

**NOTE:**

The notch on the lock plate moves by 1/2 notch if the plate is turned upside down.

13) Turn in the retainer on the upper side additionally by 1 notch in order to apply preload on taper roller bearing.

14) Tighten temporarily both the upper and lower lock plates and mark both holder and lock plate for later readjustment.

15) Turn transmission main shaft several times while tapping around retainer lightly with plastic hammer.

16) Inspect and adjust backlash and tooth contact of hypoid gear. <Ref. to MT-71, INSPECTION, Front Differential Assembly.>

17) After checking the tooth contact of hypoid gears, remove the lock plate. Then loosen retainer until the O-ring groove appears. Fit O-ring into the groove and tighten retainer into the position where retainer has been tightened in.

Tighten lock plate.

**NOTE:**

Carry out this job on both upper and lower retainers.

**Tightening torque:**

**T: 24.5 N·m (2.5 kgf-m, 18.1 ft-lb)**

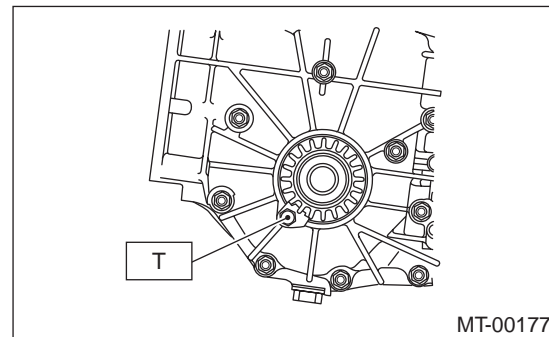

18) Selecting of main shaft rear plate <Ref. to MT-58, ADJUSTMENT, Main Shaft Assembly for Single-Range.>

19) Install clutch release lever and bearing. <Ref. to CL-13, INSTALLATION, Release Bearing and Lever.>

20) Install transfer case with extension case assembly. <Ref. to MT-38, INSTALLATION, Transfer Case and Extension Case Assembly.>

21) Install the manual transmission assembly into the vehicle. <Ref. to MT-28, INSTALLATION, Manual Transmission Assembly.>

### C: INSPECTION

Check the transmission case for cracks, damage, and oil leaks.

MT-52