

## SHIFTER FORK AND ROD

MANUAL TRANSMISSION AND DIFFERENTIAL

### 20. Shifter Fork and Rod

#### A: REMOVAL

- 1) Remove the manual transmission assembly from vehicle. <Ref. to MT-26, REMOVAL, Manual Transmission Assembly.>
- 2) Remove back-up light switch and neutral position switch. <Ref. to MT-34, REMOVAL, Switches and Harness.>
- 3) Remove transfer case with extension case assembly. <Ref. to MT-38, REMOVAL, Transfer Case and Extension Case Assembly.>
- 4) Remove transmission case. <Ref. to MT-50, REMOVAL, Transmission Case.>
- 5) Remove drive pinion shaft assembly. <Ref. to MT-59, REMOVAL, Drive Pinion Shaft Assembly.>
- 6) Remove main shaft assembly. <Ref. to MT-53, REMOVAL, Main Shaft Assembly for Single-Range.>
- 7) Remove differential assembly. <Ref. to MT-67, REMOVAL, Front Differential Assembly.>
- 8) Drive out straight pin with ST, and 5th shifter fork.

ST 398791700 STRAIGHT PIN REMOVER

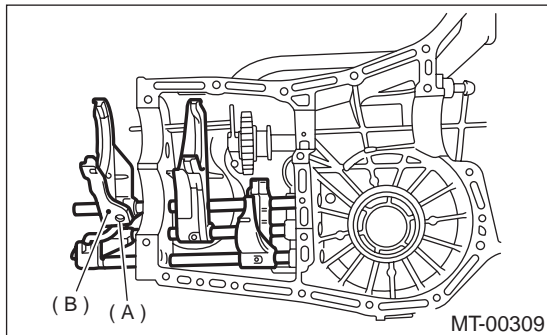

- (A) Straight pin  
(B) 5th shifter fork

- 9) Remove plugs, springs and checking balls.

- 10) Drive out straight pin, and pull out 3-4 fork rod and shifter fork.

#### NOTE:

When removing rod, keep other rods in neutral. Also, when pulling out straight pin, remove it toward the inside of the case so that it does not hit against the case.

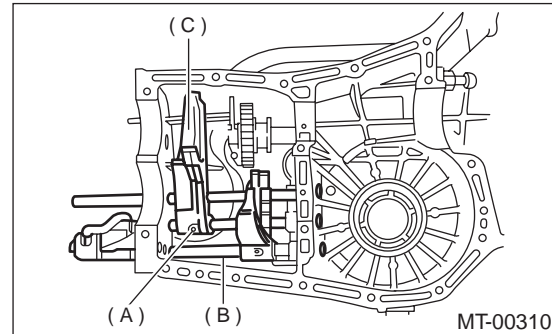

- (A) Straight pin  
(B) 3-4 fork rod  
(C) Shifter fork

- 11) Drive out straight pin, and pull out 1-2 fork rod and shifter fork.

- 12) Remove outer snap ring, and pull out reverse shifter rod arm from reverse fork rod. Then take out ball, spring and interlock plunger from rod. And then remove rod.

#### NOTE:

When pulling out reverse shifter rod arm, be careful not to let ball pop out of arm.

- 13) Remove reverse shifter lever.

MT-77

## SHIFTER FORK AND ROD

### MANUAL TRANSMISSION AND DIFFERENTIAL

#### B: INSTALLATION

1) Install reverse arm fork spring, ball and interlock plunger to reverse fork rod arm. Insert reverse fork rod into hole in reverse fork rod arm, and hold it with outer snap ring using ST.

##### NOTE:

Apply grease to plunger to prevent it from falling.

ST 399411700 ACCENT BALL INSTALLER

2) Position ball, spring and new gasket in reverse shifter rod hole, on left side transmission case, and tighten checking ball plug.

3) Install 1-2 fork rod into 1-2 shifter fork via the hole on the rear of the transmission case.

4) Align the holes in rod and fork, and new drive straight pin into these holes using ST.

##### NOTE:

- Set other rods to neutral.
- Make sure interlock plunger is on the 3-4 fork rod side.

ST 398791700 STRAIGHT PIN REMOVER

5) Install interlock plunger onto 3-4 fork rod.

##### NOTE:

Apply a coat of grease to plunger to prevent it from falling.

6) Install 3-4 fork rod into 3-4 shifter fork via the hole on the rear of transmission case.

7) Align the holes in rod and fork, and new drive straight pin into these holes.

##### NOTE:

- Set reverse fork rod to neutral.
- Make sure interlock plunger (installing before) is on the reverse fork rod side.

ST 398791700 STRAIGHT PIN REMOVER

8) Install 5th shifter fork onto the rear of reverse fork rod. Align holes in the two parts and new drive straight pin into place.

ST 398791700 STRAIGHT PIN REMOVER

9) Position balls, checking ball springs and new gaskets into 3-4 and 1-2 rod holes, and install plugs.

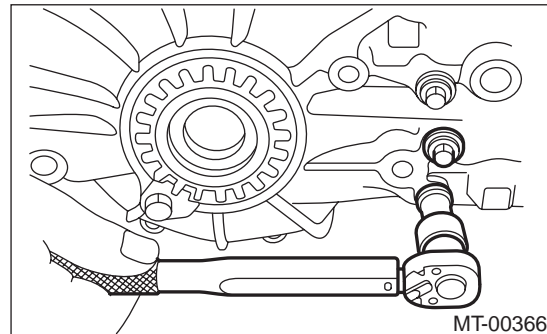

10) Install differential assembly. <Ref. to MT-67, INSTALLATION, Front Differential Assembly.>

11) Install main shaft assembly.

12) Install drive pinion shaft assembly. <Ref. to MT-59, INSTALLATION, Drive Pinion Shaft Assembly.>

13) Install transmission case. <Ref. to MT-51, INSTALLATION, Transmission Case.>

14) Install transfer case with extension case assembly. <Ref. to MT-38, INSTALLATION, Transfer Case and Extension Case Assembly.>

15) Install back-up light switch and neutral position switch. <Ref. to MT-34, INSTALLATION, Switches and Harness.>

16) Install the manual transmission assembly to vehicle. <Ref. to MT-28, INSTALLATION, Manual Transmission Assembly.>

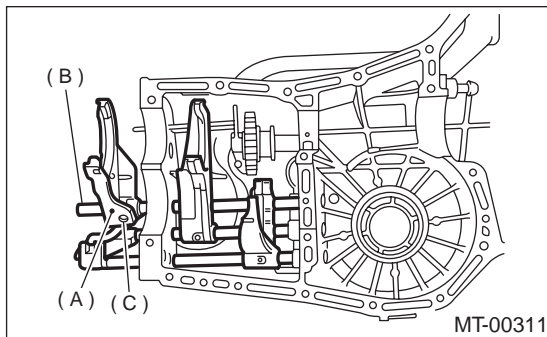

- (A) 5th shifter fork
- (B) Reverse fork rod
- (C) Straight pin

## MT-78

## SHIFTER FORK AND ROD

MANUAL TRANSMISSION AND DIFFERENTIAL

### C: INSPECTION

- 1) Check the shift shaft and shift rod for damage. Replace if damaged.
- 2) Gearshift mechanism  
Repair or replace the gearshift mechanism if excessively worn, bent, or defective in any way.
- 3) Inspect clearance between 1st, 2nd driven gear and reverse driven gear. If any clearance is not within specifications, replace shifter fork as required.

**Clearance (a) and (b):**  
**9.5 mm (0.374 in)**

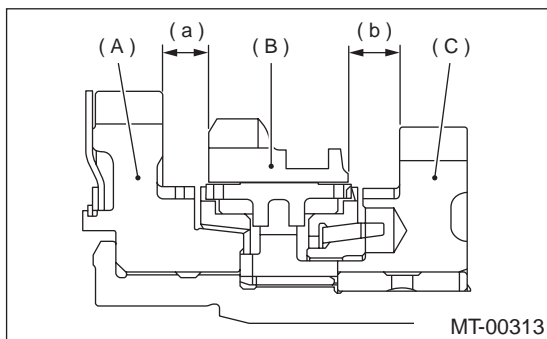

- (A) 1st driven gear
- (B) Reverse driven gear
- (C) 2nd driven gear

1st-2nd shifter fork		
Part No.	Mark	Remarks
32804AA060	1	Approach to 1st gear by 0.2 mm (0.008 in).
32804AA070	—	Standard
32804AA080	3	Become distant from 2nd gear by 0.2 mm (0.008 in).

- 4) Inspect clearance between 3rd, 4th drive gear and coupling sleeve. If any clearance is not within specifications, replace shifter fork as required.

**Clearance (a) and (b):**  
**9.3 mm (0.366 in)**

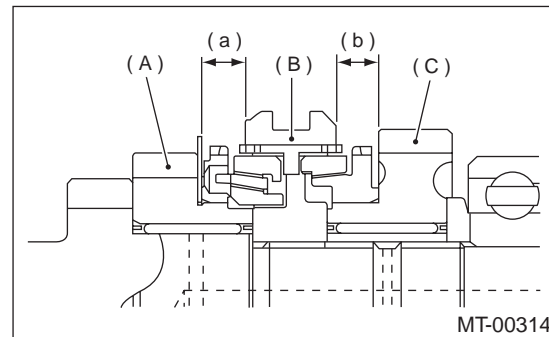

- (A) 3rd drive gear
- (B) Coupling sleeve
- (C) 4th drive gear

3rd-4th shifter fork		
Part No.	Mark	Remarks
32810AA061	1	Approach to 4th gear by 0.2 mm (0.008 in).
32810AA071	—	Standard
32810AA101	3	Become distant from 3rd gear by 0.2 mm (0.008 in).

- 5) Inspect clearance between 5th drive gear and coupling sleeve. If any clearance is not within specifications, replace shifter fork as required.

**Clearance (a):**  
**9.3 mm (0.366 in)**

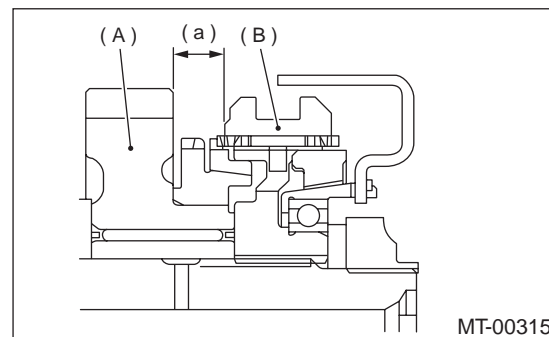

- (A) 5th drive gear
- (B) Coupling sleeve

MT-79

## SHIFTER FORK AND ROD

### MANUAL TRANSMISSION AND DIFFERENTIAL

5th shifter fork		
Part No.	Mark	Remarks
32812AA201	7	Approach to 5th gear by 0.2 mm (0.008 in).
32812AA211	—	Standard
32812AA221	9	Become distant from 5th gear by 0.2 mm (0.008 in).

6) Inspect rod end clearances (A) and (B). If any clearance is not within specifications, replace rod or fork as required.

**Clearance (A):**

**3rd — 4th to 5th:**

**0.5 — 1.3 mm (0.020 — 0.051 in)**

**Clearance (B):**

**1st — 2nd to 3rd — 4th:**

**0.4 — 1.4 mm (0.016 — 0.055 in)**

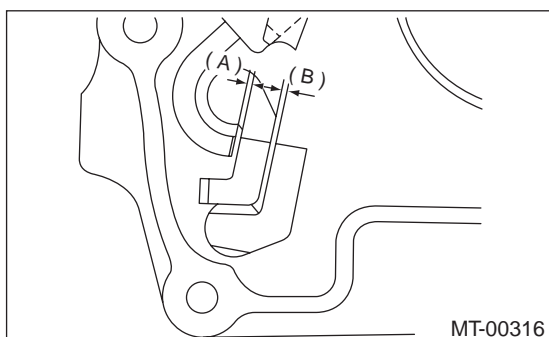

**MT-80**