

POWER SUPPLY ROUTING

WIRING SYSTEM

4. Power Supply Routing

A: SCHEMATIC

1. 4-CYLINDER ENGINE MODEL

P-SUP(H4)-01

P-SUP(H4)-01

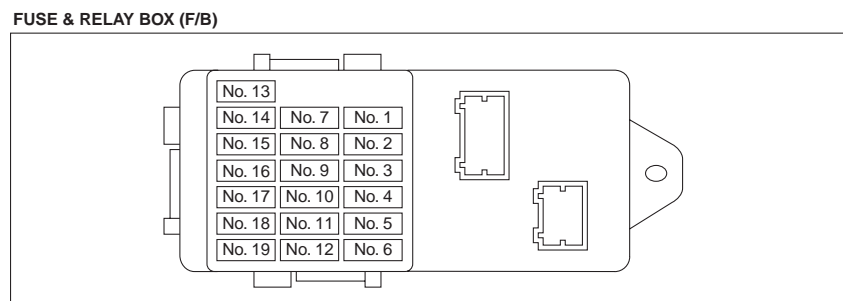
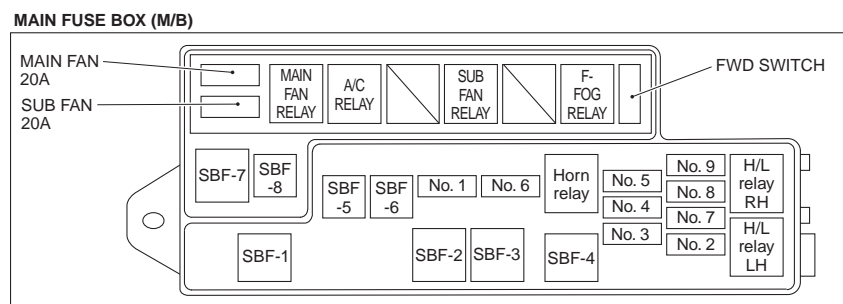

WI-00504

POWER SUPPLY ROUTING

WIRING SYSTEM

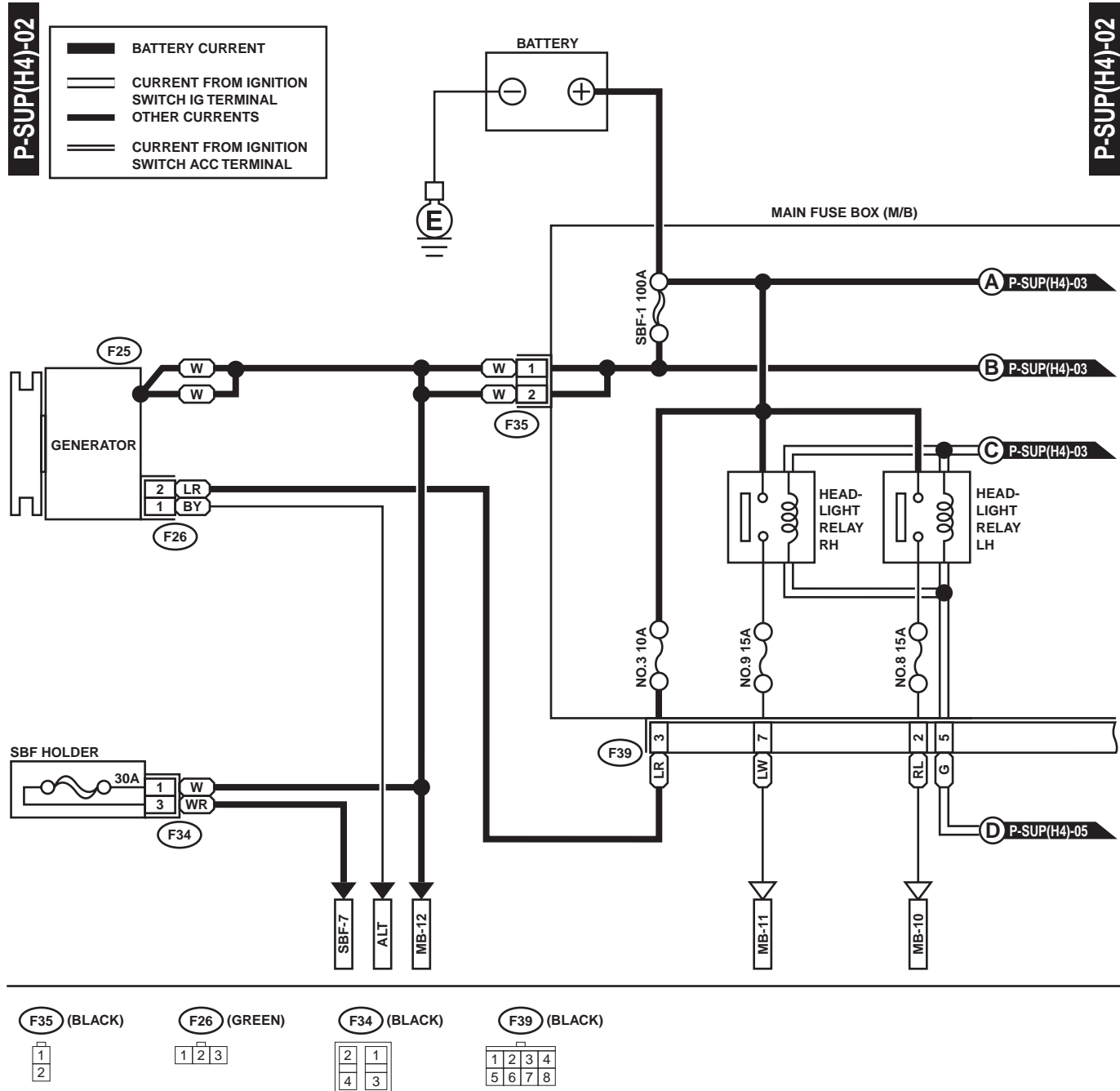

WI-01055

POWER SUPPLY ROUTING

WIRING SYSTEM

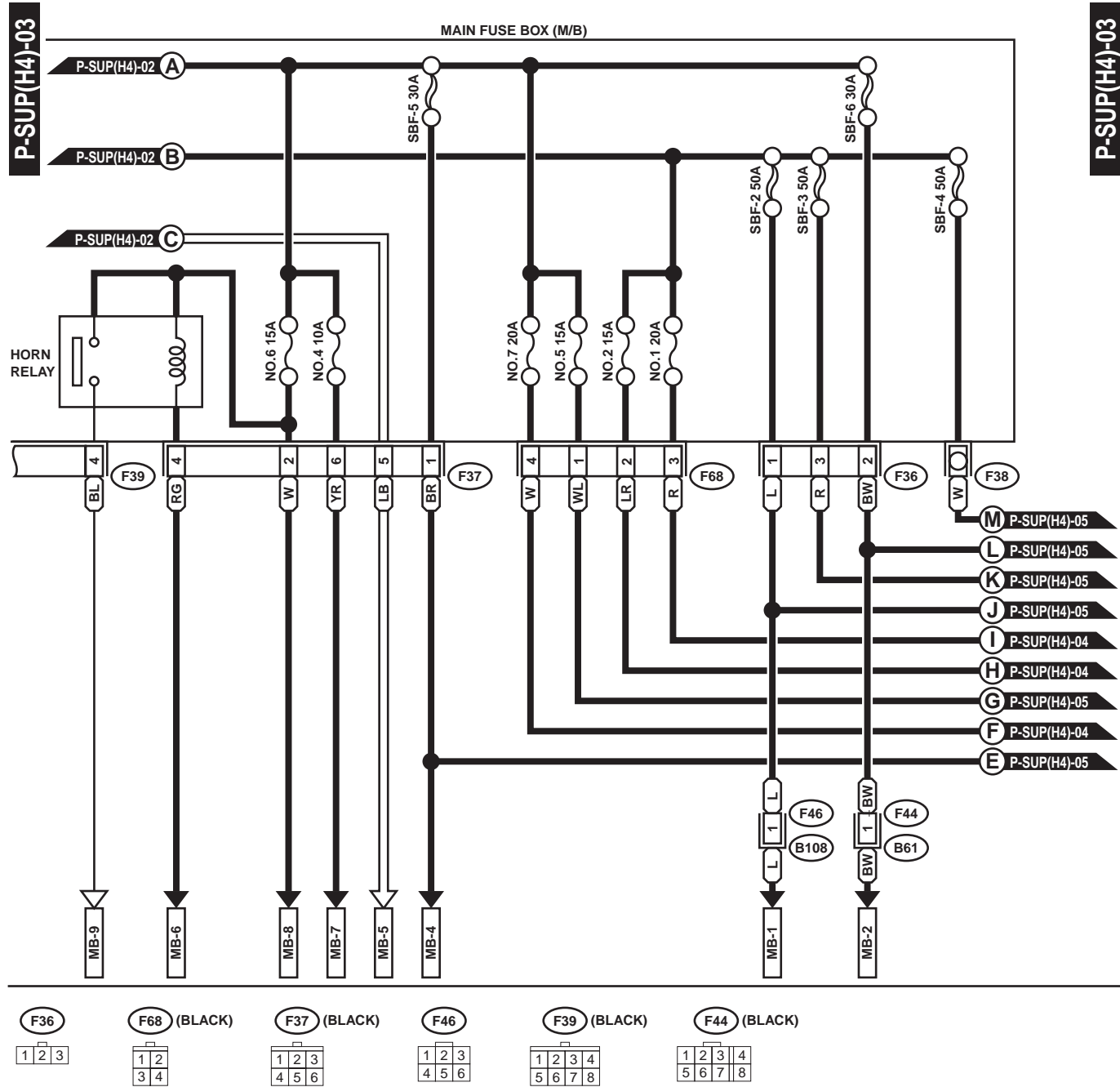

WI-00506

POWER SUPPLY ROUTING

WIRING SYSTEM

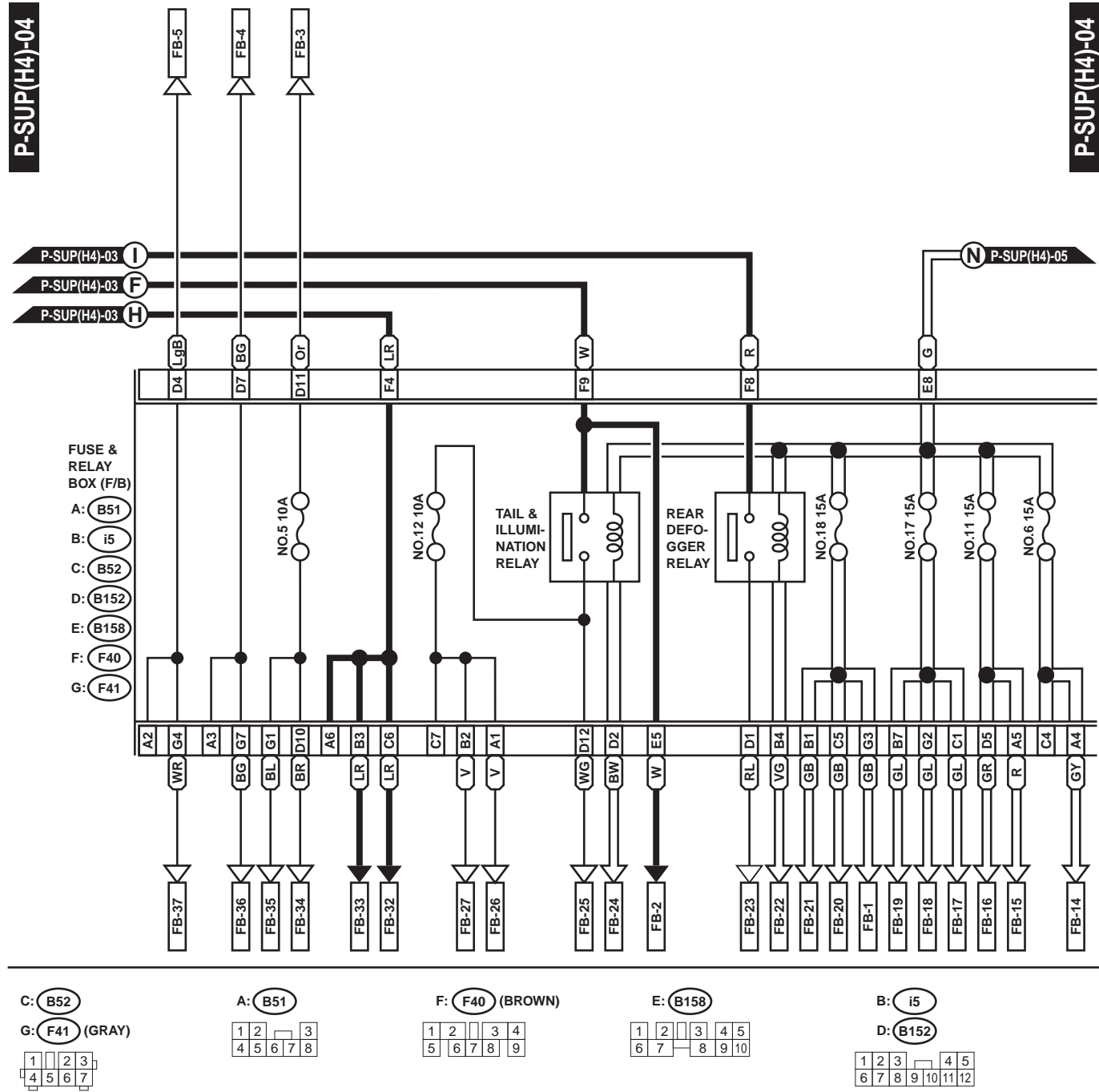

WI-00507

POWER SUPPLY ROUTING

WIRING SYSTEM

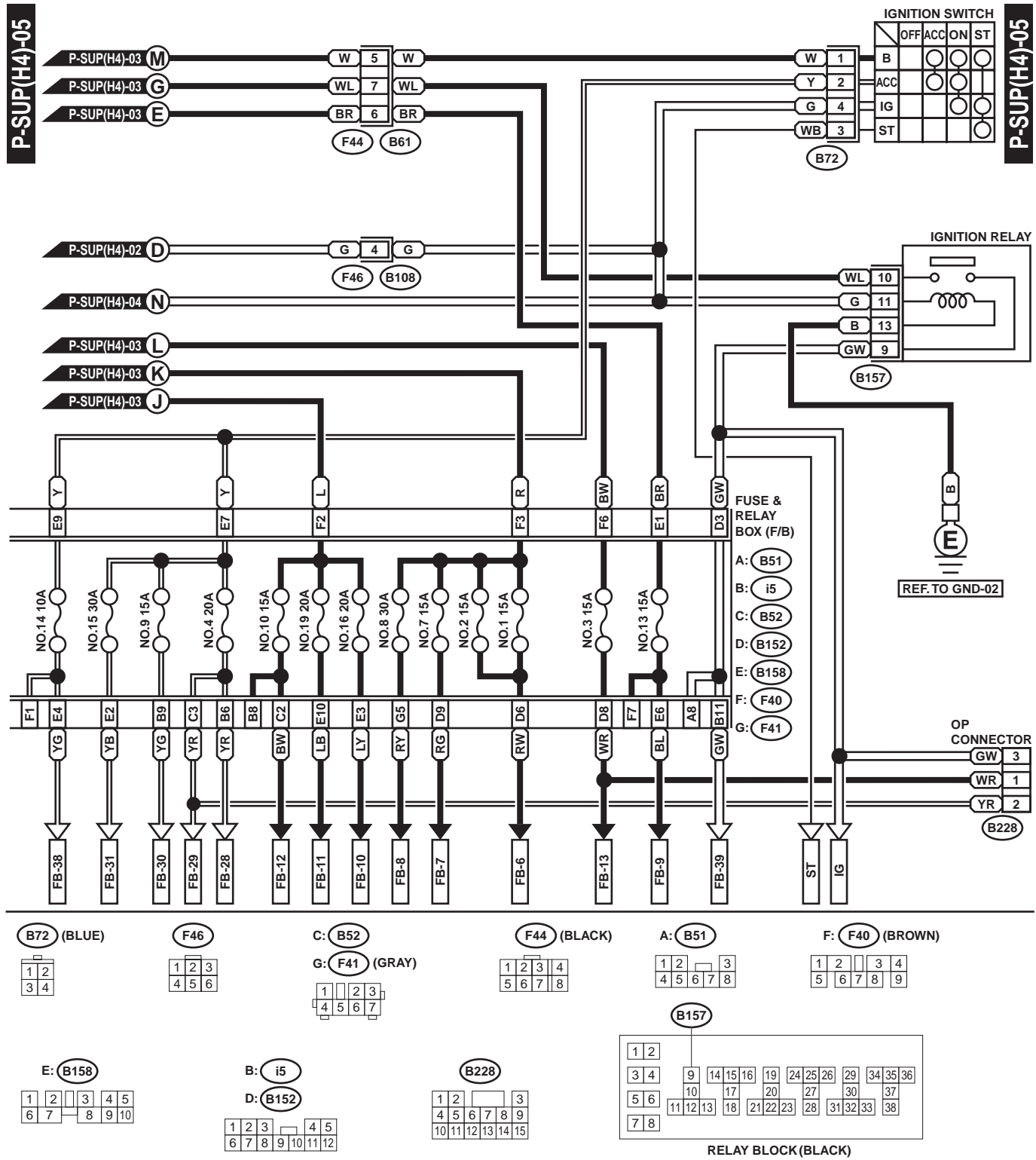

WI-00508

POWER SUPPLY ROUTING

WIRING SYSTEM

No.	Load
MB-1	Cargo Light Fuse (Seat heater/rear accessory power supply relay)
MB-2	Power window circuit breaker
MB-4	Data link connector Engine control module Main relay
MB-5	Cruise control sub switch Day time running light control module OP connector
MB-6	Horn switch Keyless entry control module Security horn relay Sports shift switch
MB-7	Transmission control module (AT)
MB-8	Hazard switch Keyless entry control module Key warning switch Stop & turn module (Pick-up)
MB-9	Horn
MB-10	Headlight LH
MB-11	Combination meter Headlight RH
MB-12	A/C relay holder SBF holder
SBF-7	ABS control module
ALT	Combination meter OP connector
IG	Check connector Ignition relay-2 Keyless entry control module OP connector Security control module Vehicle speed sensor (MT)
ST	Cruise control module Engine control module (AT) Inhibitor switch (AT) Interrupt relay Starter interlock relay
FB-1	ABS control module Main fan relay
FB-2	Parking switch Security control module
FB-3	Parking switch Security control module
FB-4	Combination meter Combination switch (Lighting) Hazard switch Keyless entry control module Rear combination light Stop & turn module (Pick-up) Trailer connector (Wagon)

No.	Load
FB-5	Combination meter Combination switch (Lighting) Hazard switch Keyless entry control module Rear combination light Stop & turn module (Pick-up) Trailer connector (Wagon)
FB-6	Blower motor relay
FB-7	Front fog light relay
FB-8	ABS control module
FB-9	Fuel pump relay
FB-10	Stop light switch
FB-11	Baja light relay (Pick-up) Wiper deicer relay
FB-12	Trailer connector (Wagon) (Pick-up)
FB-13	Integrated module Keyless buzzer Keyless entry control module OP connector
FB-14	Airbag control module
FB-15	Airbag control module
FB-16	Daytime running light control module Daytime running light relay Engine control module Fuel pump relay Ignition coil and ignitor Integrated module Transmission control module
FB-17	A/C pressure switch Blower motor relay
FB-18	A/C relay Sub fan relay
FB-19	Auto A/C control module Manual A/C control module
FB-20	Back-up light switch (MT) Cruise control module Inhibitor switch (AT) Power window relay Wiper deicer relay
FB-21	Cruise control main switch
FB-22	Auto A/C control module Engine control module Manual A/C control module
FB-23	Choke coil Rear defogger Rear defogger condenser
FB-24	Combination switch (Lighting) Engine control module OP connector
FB-25	Parking switch
FB-26	AT select lever illumination light Integrated module OP connector Power window main switch Seat heater switch

POWER SUPPLY ROUTING

WIRING SYSTEM

No.	Load
FB-27	Audio Auto A/C control module Ashtray illumination light Baja light switch CD illumination light Cigar lighter illumination light Combination meter Cruise control main switch Front fog switch Globe box light Hazard switch Manual A/C control module VDC off switch Wiper deicer switch
FB-28	Auto A/C control module Front accessory power supply socket Multiple power socket relay (Option)
FB-29	Compass mirror Integrated module Mirror heater LH Mirror heater RH OP connector Rear accessory power supply relay Remote control rearview mirror switch Vanity mirror illumination light
FB-30	Audio
FB-31	Combination switch (Washer) Front washer motor Front wiper motor
FB-32	Combination meter Integrated module Key illumination light Key warning and step light diode Luggage room light Room light Security control module Security horn relay Stop light Step light Trunk room light
FB-33	Audio Auto A/C control module Combination meter
FB-34	License plate light LH License plate light RH Rear combination light LH Rear combination light RH Rear finisher light LH Rear finisher light RH Trailer connector (Wagon) (Pick-up)
FB-35	Front clearance light LH Front clearance light RH
FB-36	Front turn signal light LH (Up, Lo)
FB-37	Front turn signal light RH (Up, Lo)
FB-38	Rear washer motor Rear wiper intermittent module Rear wiper motor
FB-39	Combination meter Hazard switch

POWER SUPPLY ROUTING

WIRING SYSTEM

2. 6-CYLINDER ENGINE MODEL

P-SUP(H6)-01

P-SUP(H6)-01

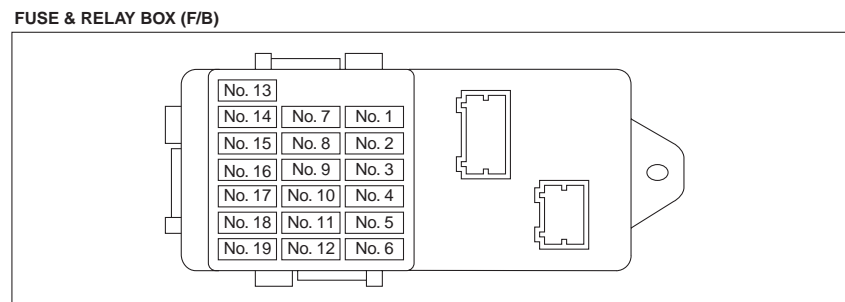
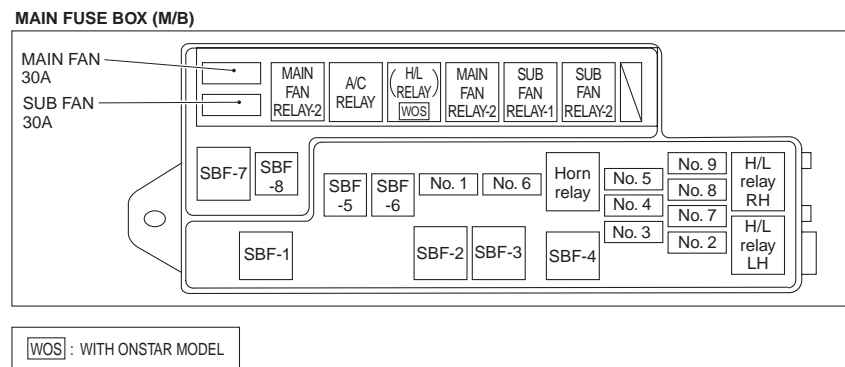

WI-00509

POWER SUPPLY ROUTING

WIRING SYSTEM

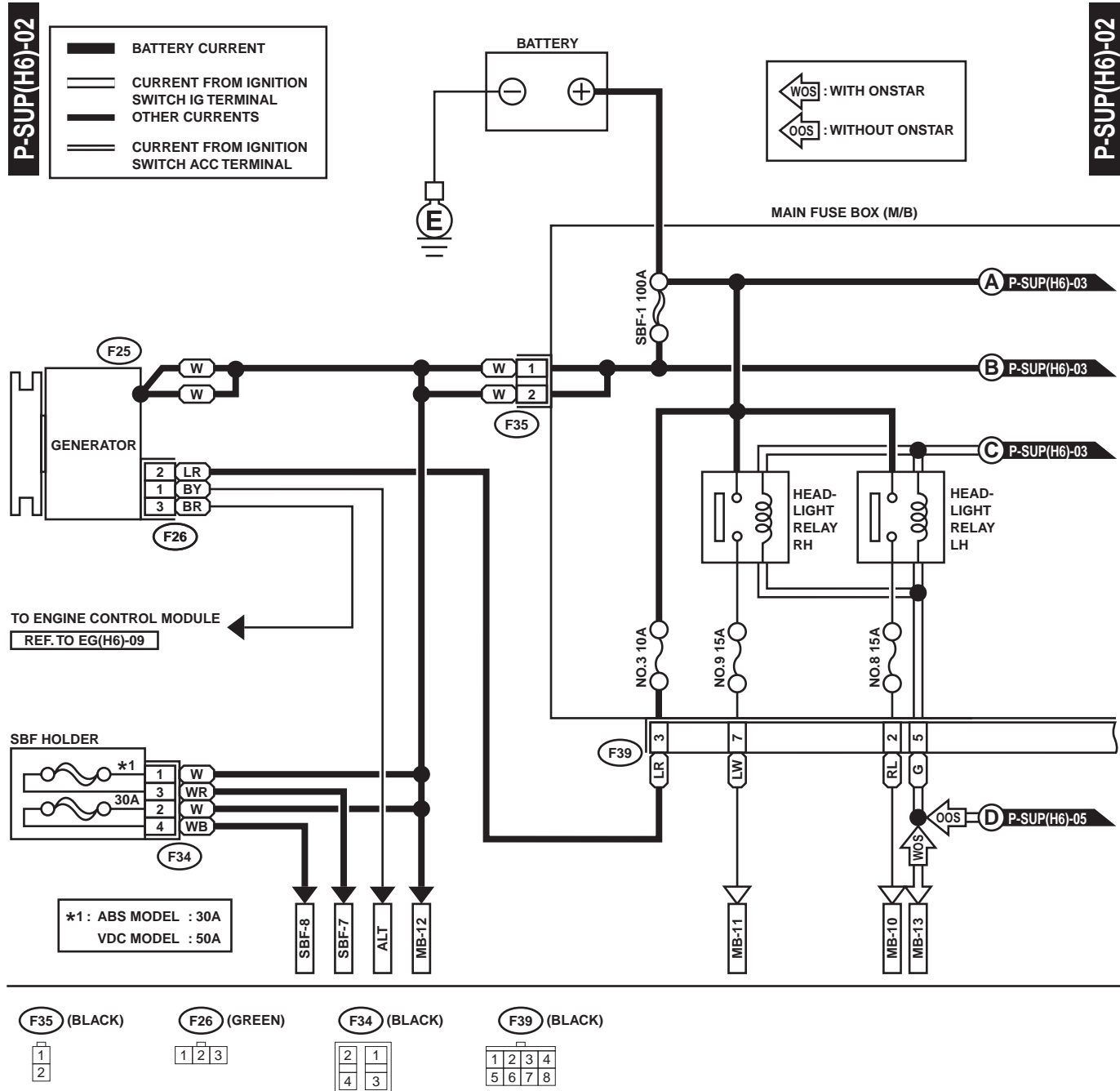

WI-00510

POWER SUPPLY ROUTING

WIRING SYSTEM

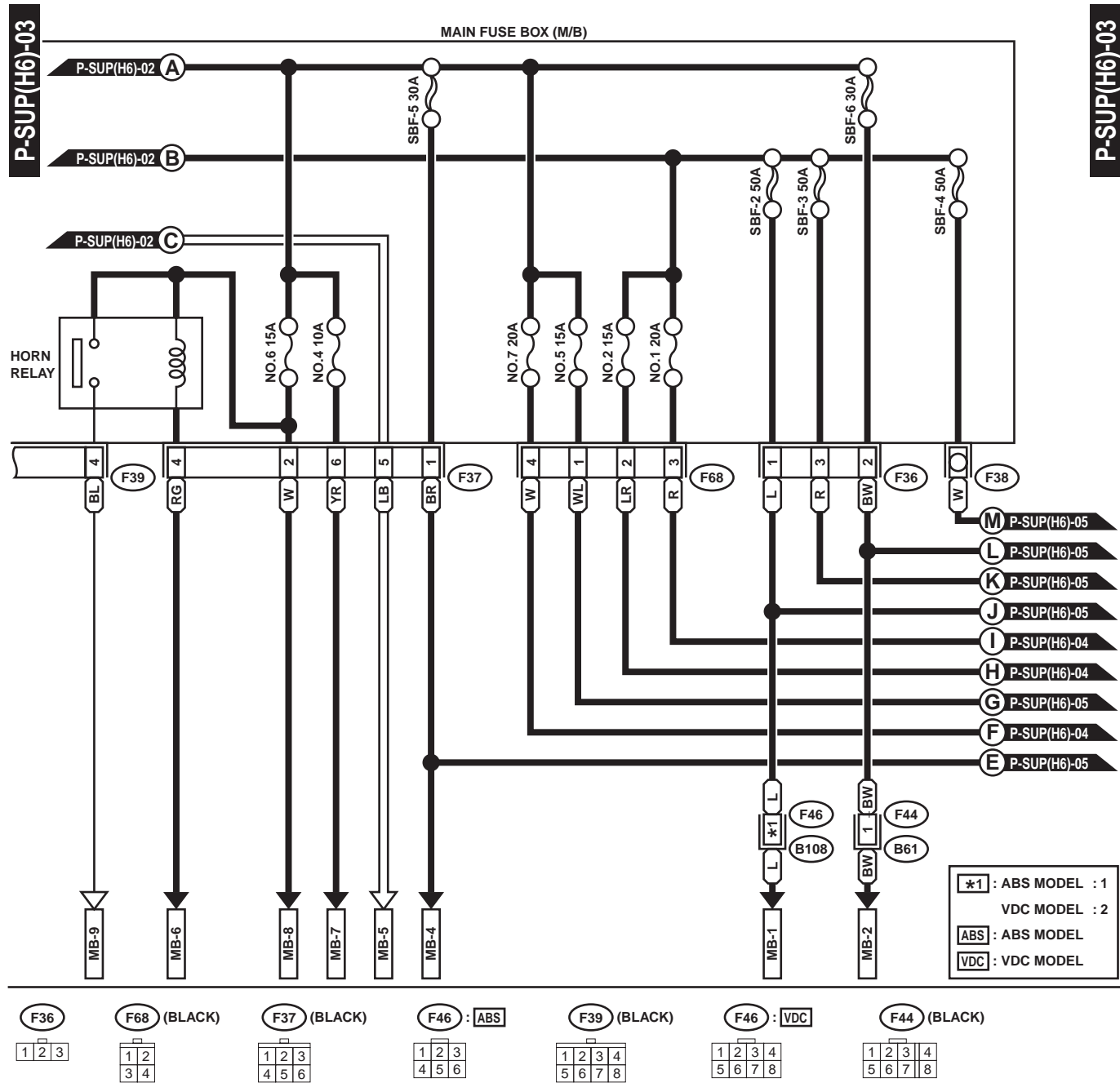

WI-00511

POWER SUPPLY ROUTING

WIRING SYSTEM

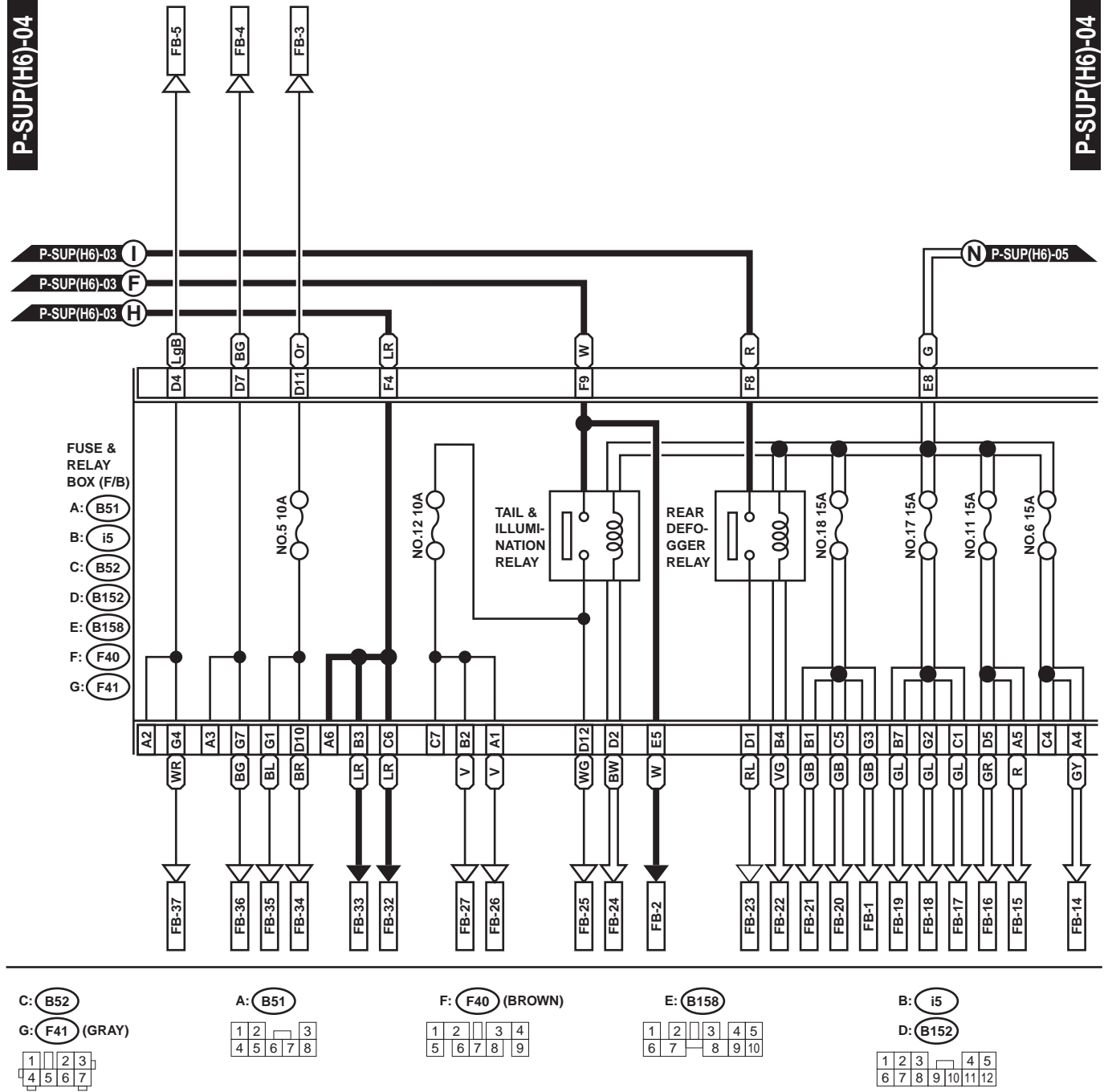

WI-00512

POWER SUPPLY ROUTING

WIRING SYSTEM

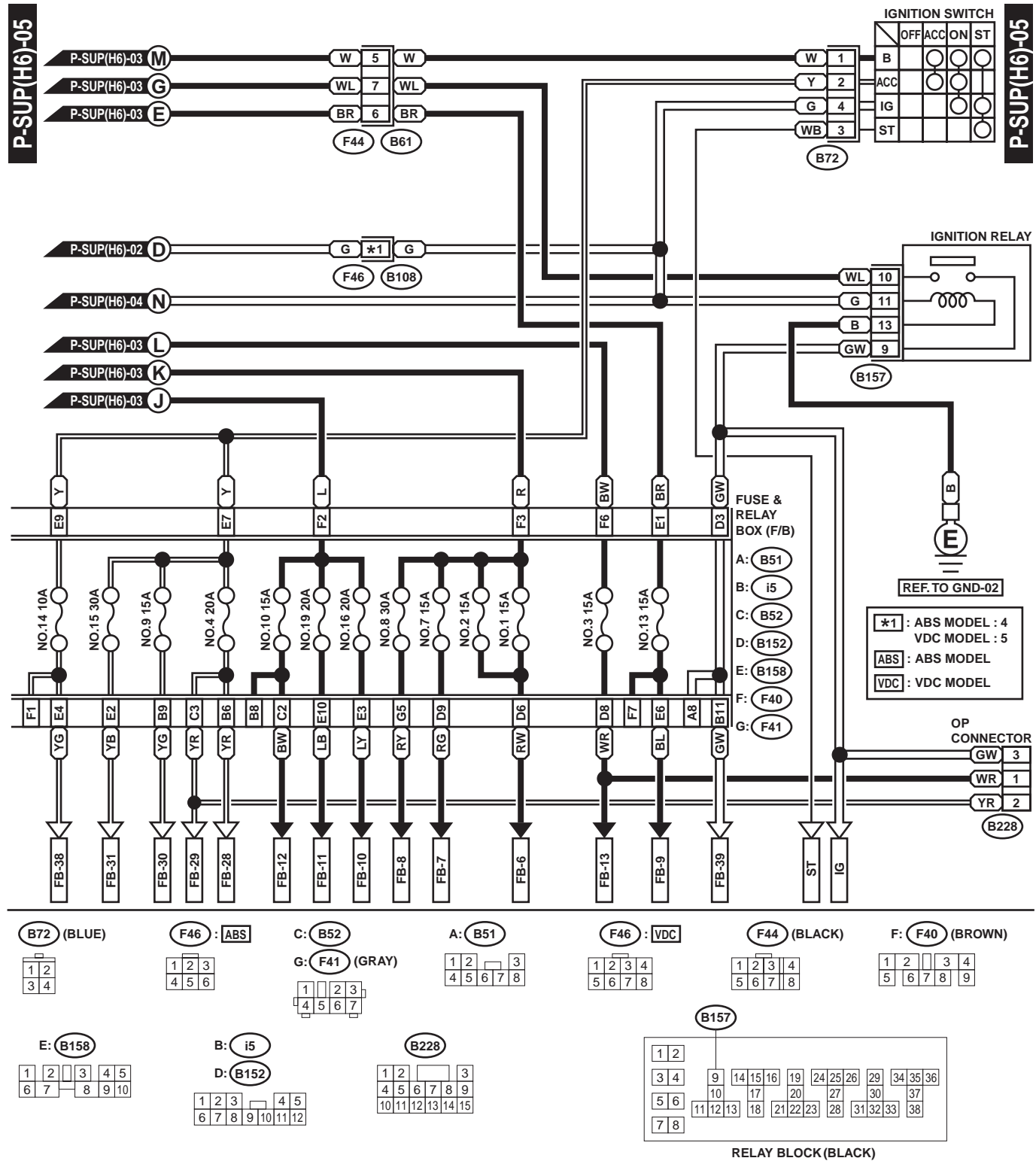

WI-00513

POWER SUPPLY ROUTING

WIRING SYSTEM

No.	Load
MB-1	Relay box
MB-2	Power window circuit breaker
MB-4	Data link connector Engine control module Main relay
MB-5	Daytime running light control module Daytime running light diode OP connector
MB-6	Horn switch Keyless entry control module Security horn relay Vehicle interface module
MB-7	Transmission control module
MB-8	Hazard switch Keyless entry control module Key warning switch
MB-9	Horn
MB-10	Headlight LH
MB-11	Combination meter Headlight RH
MB-12	A/C relay holder SBF holder
MB-13	Onstar relay-2
SBF-7	ABS control module
SBF-8	Relay box (VDC)
ALT	Combination meter
IG	Check connector Ignition relay-2 Keyless entry control module Security control module
ST	Cruise control module Engine control module Inhibitor switch (AT) Interrupt relay (Onstar) Key switch
FB-1	ABS control module Main fan relay-1 Main fan relay-2 VDC module
FB-2	Parking switch Security control module
FB-3	Parking switch Security control module
FB-4	Combination meter Combination switch (Lighting) Hazard switch Keyless entry control module Rear combination light LH Trailer connector (Wagon)
FB-5	Combination meter Combination switch (Lighting) Hazard switch Keyless entry control module Rear combination light RH Trailer connector (Wagon)
FB-6	Blower motor relay
FB-7	Front fog light relay

No.	Load
FB-8	ABS control module Relay box (VDC)
FB-9	Fuel pump relay Main fan relay-1
FB-10	Stop light switch
FB-11	Wiper deicer relay
FB-12	Trailer connector (Wagon)
FB-13	Integrated module Keyless buzzer Keyless entry control module OP connector
FB-14	Airbag control module
FB-15	Airbag control module
FB-16	Daytime running light control module Daytime running light relay Engine control module Fuel pump relay Ignition coil No. 1— 6 Integrated module Transmission control module
FB-17	A/C pressure switch Blower motor relay Fan relay
FB-18	A/C pressure switch Sub fan relay-1 Sub fan relay-2
FB-19	Auto A/C control module Manual A/C control module Vehicle interface module
FB-20	Cruise control module Inhibitor switch (AT) Power window relay Wiper deicer relay
FB-21	Cruise control main switch
FB-22	Auto A/C control module Engine control module
FB-23	Rear defogger Rear defogger condenser
FB-24	Combination switch (Lighting) Engine control module OP connector
FB-25	Parking switch
FB-26	AT select lever illumination light Integrated module Seat heater switch OP connector Power window main switch

POWER SUPPLY ROUTING

WIRING SYSTEM

No.	Load
FB-27	Audio Auto A/C control module Ashtray illumination light CD illumination light Cigar lighter illumination light Combination meter Cruise control main switch Front fog light switch Glove box light Hazard switch Manual A/C control module Wiper deicer switch
FB-28	Auto A/C control module Front accessory power supply relay Multiple power socket relay (Option)
FB-29	Compass mirror Integrated module Mirror heater LH Mirror heater RH Remote control rearview mirror switch Rear accessory power supply relay Vanity mirror illumination light
FB-30	Audio Vehicle interface module
FB-31	Combination switch (Wiper) Front washer motor Front wiper motor
FB-32	Auto A/C control module Combination meter Key switch illumination light Integrated module Luggage room light Onstar relay Room light Security control module Security horn relay Spot light Step light Trunk room light
FB-33	Audio Auto A/C control module Combination meter Vehicle interface module
FB-34	License plate light LH License plate light RH Rear finisher light LH Rear finisher light RH Rear combination light LH Rear combination light RH Trailer connector (Wagon)
FB-35	Front clearance light LH Front clearance light RH
FB-36	Front turn signal light LH (Up, Lo)
FB-37	Front turn signal light RH (Up, Lo)
FB-38	Rear washer motor Rear wiper intermittent module Rear wiper motor
FB-39	Combination meter Hazard switch