

# STOP LIGHT SYSTEM

WIRING SYSTEM

## 30. Stop Light System

### A: SCHEMATIC

#### 1. SEDAN MODEL

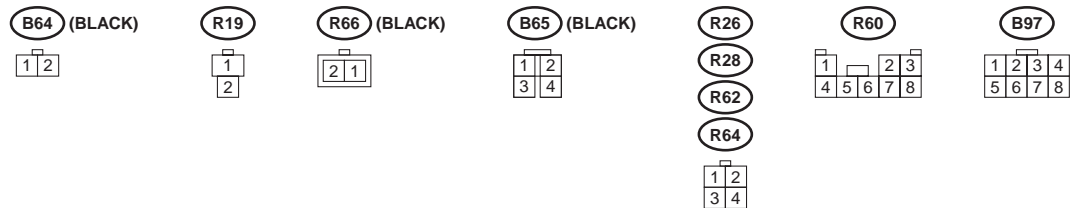
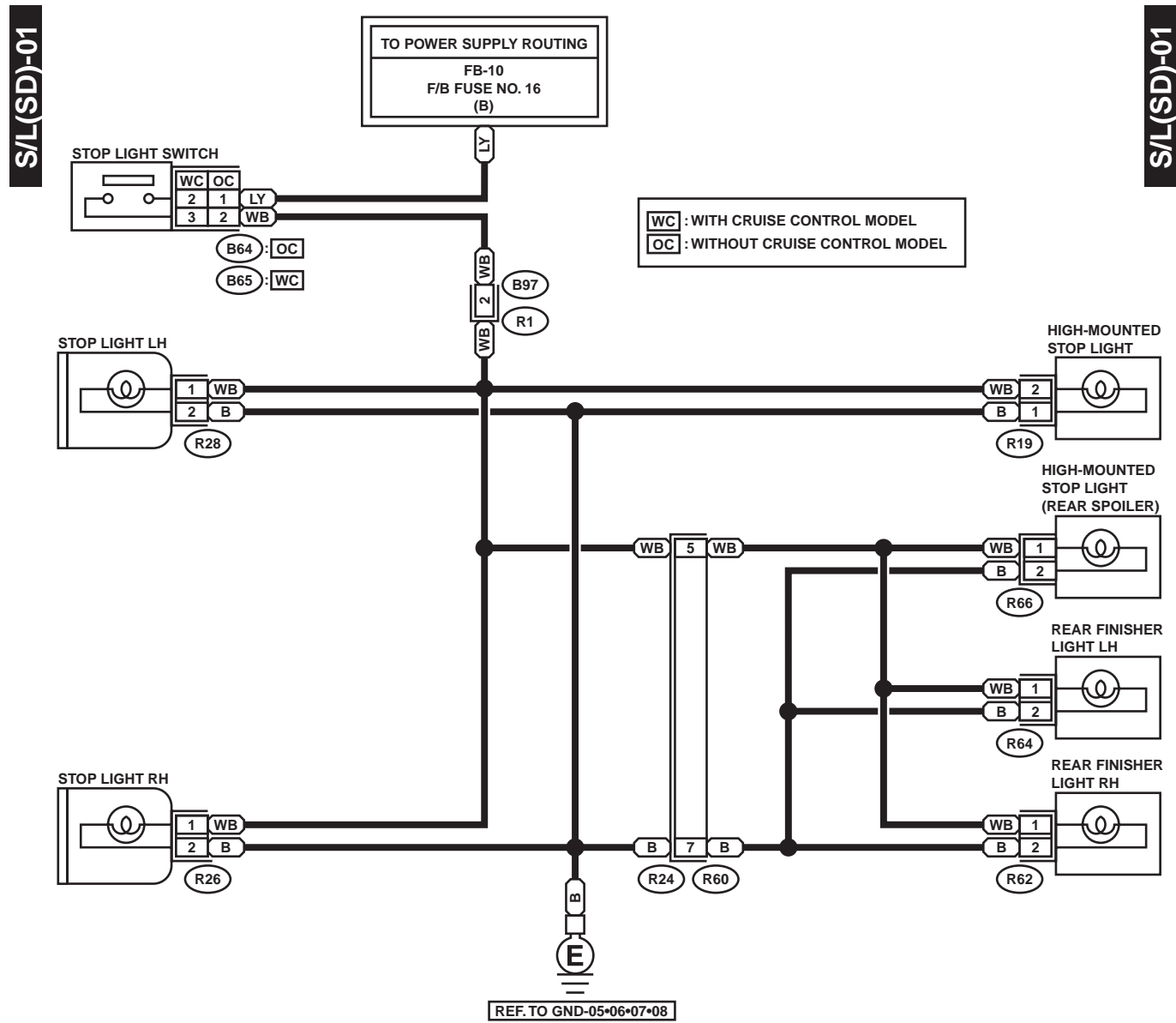

WI-00661

# STOP LIGHT SYSTEM

WIRING SYSTEM

## 2. WAGON MODEL

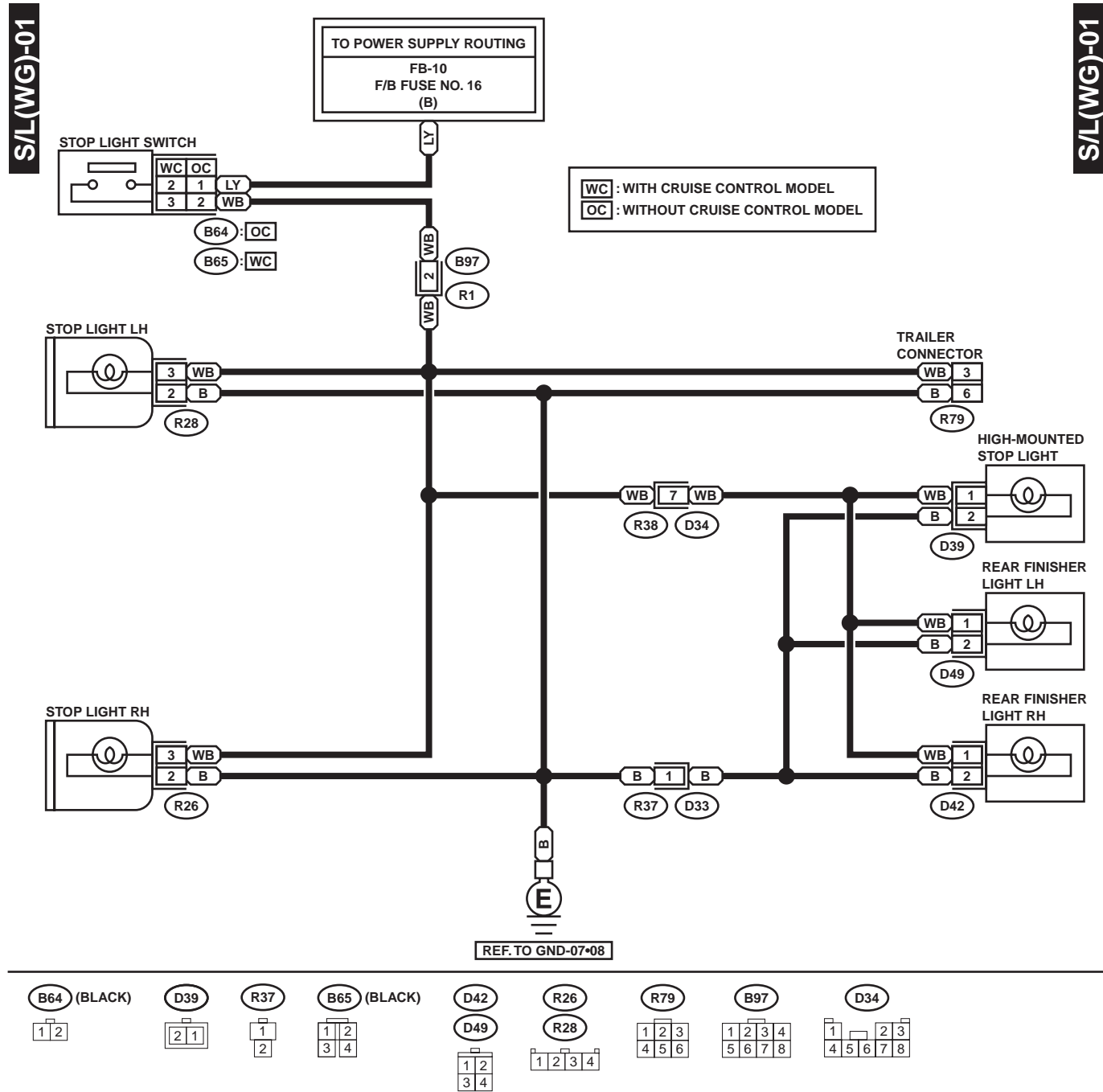

WI-00662

# STOP LIGHT SYSTEM

WIRING SYSTEM

## 3. PICK-UP MODEL

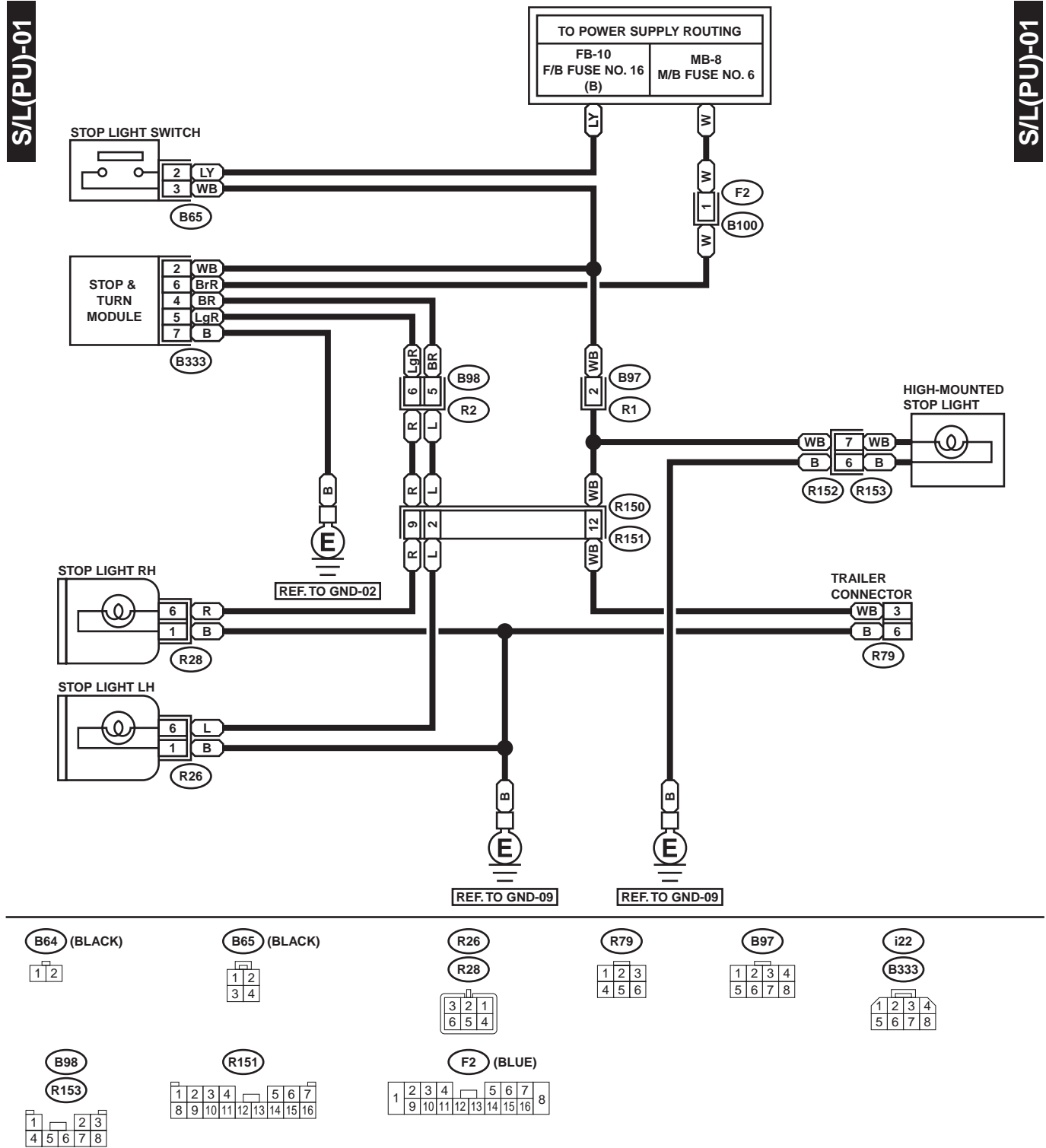

WI-00663

## STOP LIGHT SYSTEM

WIRING SYSTEM

---

MEMO: