

PERIODIC MAINTENANCE SERVICES

PM

	Page
1. General Description	2
2. Schedule	3
3. Engine Oil.....	6
4. Engine Oil Filter.....	8
5. Spark Plugs.....	10
6. Drive Belt(s)	11
7. Camshaft Drive Belt	14
8. Fuel Line	17
9. Fuel Filter	18
10. Air Cleaner Element.....	19
11. Cooling System	21
12. Coolant.....	22
13. Clutch System	24
14. Transmission Oil	25
15. ATF	26
16. Front & Rear Differential Oil	28
17. Brake Line	30
18. Brake Fluid.....	32
19. Disc Brake Pads and Discs.....	33
20. Parking Brake.....	34
21. Suspension	36
22. Wheel Bearing.....	38
23. Axle Boots & Joints	39
24. Tire Rotation.....	40
25. Steering System (Power Steering).....	41
26. Supplemental Restraint System.....	44

GENERAL DESCRIPTION

PERIODIC MAINTENANCE SERVICES

1. General Description

A: GENERAL

Be sure to perform periodic maintenance in order to maintain vehicle performance and find problems before they become serious.

SCHEDULE

PERIODIC MAINTENANCE SERVICES

2. Schedule

A: MAINTENANCE SCHEDULE 1

		MAINTENANCE INTERVAL																	Remarks
		[Number of months or km (miles), whichever occurs first]																	
		Months	3	7.5	15	22.5	30	37.5	45	52.5	60	67.5	75	82.5	90	97.5	105	112.5	
× 1,000 km	4.8	12	24	36	48	60	72	81.4	96	108	120	132	144	156	168	180	192		
× 1,000 miles	3	7.5	15	22.5	30	37.5	45	52.5	60	67.5	75	82.5	90	97.5	105	112.5	120		
1	Engine oil	R	R	R	R	R	R	R	R	R	R	R	R	R	R	R	R	R	
2	Engine oil filter	R	R	R	R	R	R	R	R	R	R	R	R	R	R	R	R	R	
3	Spark plugs					R				R				R				R	For 2.5 L
										R									For 2.5 L Turbo
											R								R
4	Drive belt(s)					I				I				I		R			
5	Camshaft Drive belt					I				I				I		R			For 2.5 L Note (1)
6	Fuel line					(I)				(I)				(I)				I	Note (2)
7	Fuel filter					(R)				(R)				(R)				R	Note (2)
8	Air cleaner element					R				R				R				R	Note (3)
9	Cooling system					I				I				I				I	
10	Coolant					R				R				R				R	
11	Clutch system			I		I		I		I		I		I		I		I	
12	Transmission oil					I				I				I				I	
13	ATF					I				I				I				I	Note (4)
14	Front & rear differential oil					I				I				I				I	
15	Brake line			I		I		I		I		I		I		I		I	
16	Brake fluid					R				R				R				R	
17	Disc brake pads & discs					I				I				I				I	
18	Parking brake			I		I		I		I		I		I		I		I	
19	Suspension			I		I		I		I		I		I		I		I	
20	Wheel bearing									(I)								(I)	
21	Axle boots & joints			I		I		I		I		I		I		I		I	
22	Tire rotation		I	I	I	I	I	I	I	I	I	I	I	I	I	I	I	I	Note (5)
23	Steering system (Power steering)			I		I		I		I		I		I		I		I	
24	Supplement restraint system	Inspect every 10 years.																	

SCHEDULE

PERIODIC MAINTENANCE SERVICES

Symbols used:

R: Replace

I: Inspection

(R) or (I): Recommended service for safe vehicle operation.

NOTE:

- (1) Periodic inspection and replacement of the camshaft drive chains on the 3.0 liter models are not required.
- (2) This inspection is not required to maintain emission warranty eligibility and it does not affect the manufacturer's obligations under EPA's in-use compliance program.
- (3) When the vehicle is used in extremely dusty conditions, the air cleaner element should be replaced more often.
- (4) ATF filter is maintenance free part. ATF filter needs replacement, when it has physically damaged or ATF leaked.
- (5) A tire should be replaced when the tread wear indicator appears as a solid band across the tread. The indicators appear when the remaining tread has been worn to 1.6 mm (0.063 in) or less.

SCHEDULE

PERIODIC MAINTENANCE SERVICES

B: MAINTENANCE SCHEDULE 2

Item	Every	Repeat short distance drive	Repeat rough/muddy road drive	Extremely cold weather area	Salt or other corrosive used or coastal area	High humidity or mountain area	Repeat towing trailer
Engine oil	3.75 months	R		R			R
	6,000 km						
	3,750 miles						
Engine oil filter	3.75 months	R		R			R
	6,000 km						
	3,750 miles						
Fuel filter	15 months						
	24,000 km						
	15,000 miles						
Fuel line	15 months				I		
	24,000 km						
	15,000 miles						
Transmission oil	15 months						R
	24,000 km						
	15,000 miles						
ATF	15 months						R
	24,000 km						
	15,000 miles						
Front & rear differential oil	15 months						R
	24,000 km						
	15,000 miles						
Brake line	15 months	I	I		I		I
	24,000 km						
	15,000 miles						
Brake fluid	15 months					R	
	24,000 km						
	15,000 miles						
Disc brake pads & discs	15 months	I	I		I		I
	24,000 km						
	15,000 miles						
Parking brake	15 months	I	I		I		I
	24,000 km						
	15,000 miles						
Suspension	7.5 months		I	I	I		I
	12,000 km						
	7,500 miles						
Axle boots & joints	7.5 months	I	I	I	I		I
	12,000 km						
	7,500 miles						
Steering system (Power steering)	7.5 months	I	I	I	I		I
	12,000 km						
	7,500 miles						

ENGINE OIL

PERIODIC MAINTENANCE SERVICES

3. Engine Oil

A: REPLACEMENT

NOTE:

Replace engine oil and engine oil filter at the same time.

1) Drain engine oil by loosening engine oil drain plug.

2.5 L model

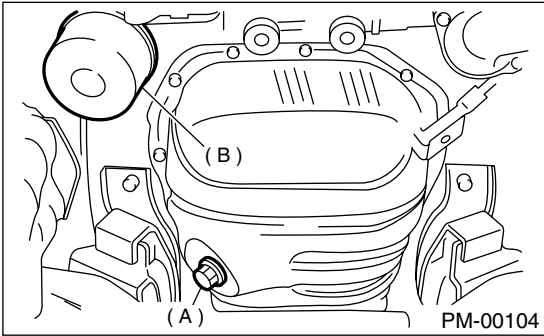

- (A) Drain plug
- (B) Oil filter

3.0 L model

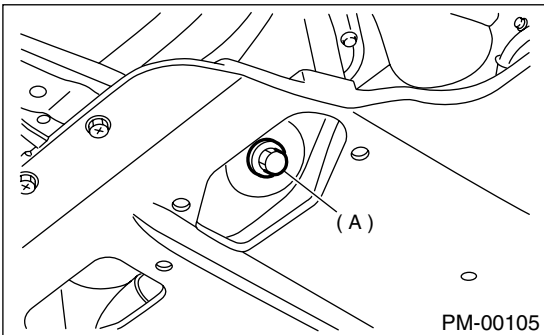

- (A) Drain plug

2) Open engine oil filler cap for quick draining of the engine oil.

2.5 L model

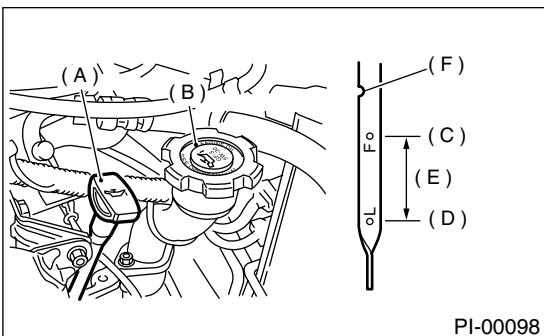

PI-00098

3.0 L model

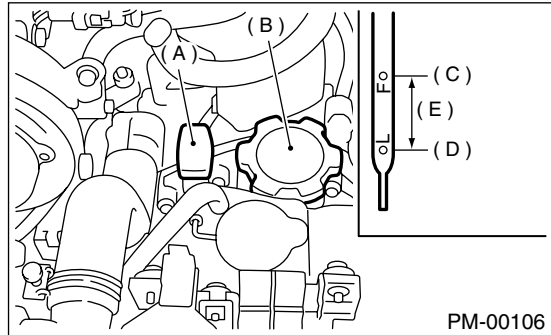

PM-00106

- (A) Oil level gauge
- (B) Engine oil filler cap
- (C) Upper level
- (D) Lower level
- (E) About 1.0 ℓ (1.1 US qt, 0.9 imp qt)
- (F) Notch

3) Replace drain plug gasket.

4) Tighten engine oil drain plug after draining engine oil.

Tightening torque:

44 N·m (4.5 kgf-m, 33 ft-lb)

5) Fill engine oil through filler pipe up to upper point on level gauge. Make sure that vehicle is placed level when checking oil level. Use engine oil of proper quality and viscosity, selected in accordance with the table in figure.

Engine oil amount for preparation:

2.5 L model

Approx. 4.0 ℓ (4.2 US qt, 3.5 Imp qt)

3.0 L model

Approx. 5.3 ℓ (5.6 US qt, 4.7 Imp qt)

SAE Viscosity No. and Applicable Temperature							
(°C)	-30	-20	-15	0	15	30	40
(°F)	-22	-4	5	32	59	86	104
LU-00248							

The proper viscosity helps vehicle get good cold and hot starting by reducing viscous friction and thus increasing cranking speed.

NOTE:

- When replenishing oil, it does not matter if the oil to be added is a different brand from that in the engine; however, use oil having the ILSAC or API classification, and SAE viscosity No. designated by SUBARU.

- If vehicle is used in desert areas with very high temperatures or for other heavy duty applications, the following viscosity oils may be used:

API classification: SL

ILSAC classification: GF-3

SAE Viscosity No.: 30, 40, 10W-50, 20W-40, 20W-50

- 6) Close engine oil filler cap.
 - 7) Start engine and warm it up for a time.
 - 8) After engine stops, recheck the oil level.
- If necessary, add engine oil up to upper level on level gauge.

2.5 L model

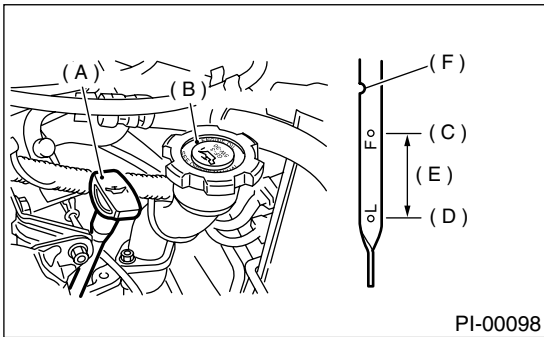

3.0 L model

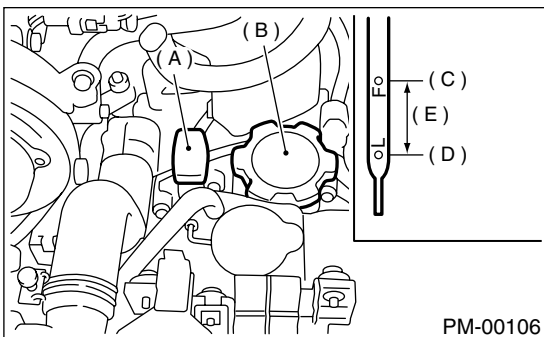

- (A) Oil level gauge
- (B) Engine oil filler cap
- (C) Upper level
- (D) Lower level
- (E) About 1.0 ℓ (1.1 US qt, 0.9 imp qt)
- (F) Notch mark

B: INSPECTION

- 1) Park vehicle on a level surface.
- 2) Remove oil level gauge and wipe it clean.
- 3) Reinsert the level gauge all the way. Be sure that the level gauge is correctly inserted and in the proper orientation.
- 4) Remove it again and note the reading. If the engine oil level is below the “L” line, add oil to bring the level up to the “F” line.
- 5) After turning off the engine, wait a few minutes for the oil to drain back into the oil pan before checking the level.
- 6) Just after driving or while the engine is warm, engine oil level may show in the range between the “F” line and the notch mark. This is caused by thermal expansion of the engine oil.
- 7) To prevent overfilling the engine oil, do not add oil above the “F” line when the engine is cold.

ENGINE OIL FILTER

PERIODIC MAINTENANCE SERVICES

4. Engine Oil Filter

A: REPLACEMENT

1. 2.5 L MODEL

1) Remove oil filter with ST.

ST 498547000	OIL FILTER WRENCH [O. D. 80 mm (3.15 in) for oil filter]
ST 18332AA000	OIL FILTER WRENCH [O. D. 68 mm (2.68 in) for oil filter]
ST 18332AA010	OIL FILTER WRENCH [O. D. 65 mm (2.56 in) for oil filter]

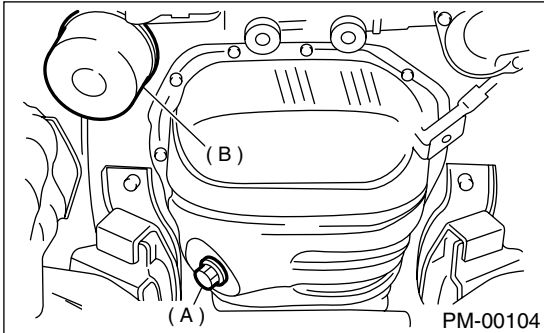

(A) Drain plug

(B) Oil filter

2) Get a new oil filter and apply a thin coat of engine oil to the seal rubber.

CAUTION:

Oil filter of O.D. 80 mm (3.15 in) is not available for TURBO model.

3) Be careful not to damage seal rubber when oil filter is turned by hand and installed.

- Oil filters with 80 mm (3.15 in) and 65 mm (2.56 in) outer diameter are further tightened (about 2/3 to 3/4 rotation) after seal rubber contacts a cylinder block or an oil cooler.
- Oil filter with 68 mm (2.68 in) outer diameter is further tightened (about 1 rotation) after seal rubber contacts a cylinder block or an oil cooler.

CAUTION:

Do not tighten excessively, or oil may leak.

4) Run engine and make sure that no oil is leaking around seal rubber.

NOTE:

The filter element and filter case are permanently joined; therefore, interior cleaning is impossible.

5) Check the engine oil level. <Ref. to PM-6, Engine Oil.>

2. 3.0 L MODEL

1) Drain engine oil by loosening engine oil drain plug.

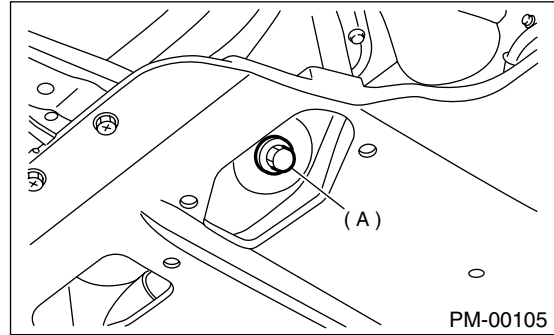

(A) Drain plug

2) Remove access lid.

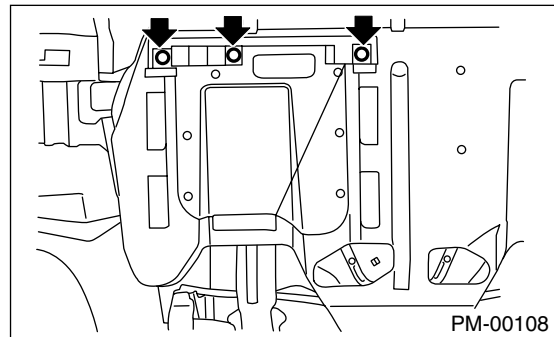

3) Remove oil filter with ST.

ST 498547000 OIL FILTER WRENCH

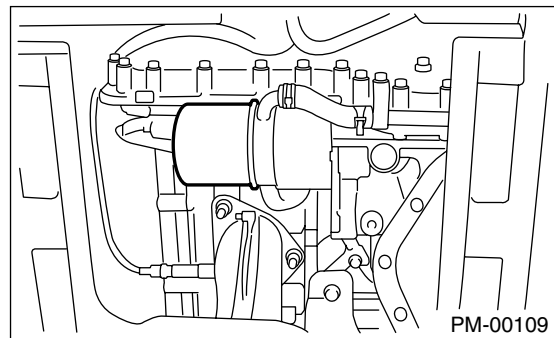

4) Clean mounting surface of oil cooler and oil filter.

5) Get a new oil filter and apply a thin coat of engine oil to the rubber seal.

6) Install oil filter by turning it by hand, being careful not to damage rubber seal.

7) Tighten more (approximately 2/3 to 3/4 turn) after the rubber seal contacts the oil cooler.

CAUTION:

Do not tighten excessively, or oil may leak.

8) Run engine and make sure that no oil is leaking around rubber seal.

NOTE:

The filter element and filter case are permanently jointed; therefore, interior cleaning is impossible.

9) Check the engine oil level. <Ref. to PM-6, Engine Oil.>

SPARK PLUGS

PERIODIC MAINTENANCE SERVICES

5. Spark Plugs

A: REPLACEMENT

1. 2.5 L MODEL

- 1) Disconnect battery ground cable.
- 2) Remove intake duct and intake chamber.
- 3) Remove washer tank and put it aside.
- 4) Disconnect spark plug cord.
- 5) Remove spark plug with a plug-wrench.

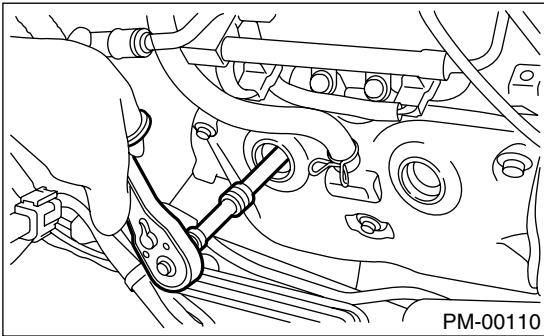

- 6) Set new spark plug.

Recommended spark plug:

Non-TURBO model (Except U5);

CHAMPION RC10YC4

NGK BKR5E-11

NGK BKR6E-11

Non-TURBO model (U5);

NGK FR5AP-11

Spark plug gap

1.0 — 1.1 mm (0.039 — 0.043 in)

TURBO model;

NGK PFR6G

Spark plug gap

0.7 — 0.8 mm (0.028 — 0.031 in)

- 7) Tighten spark plug lightly with hand, and then secure with a plug-wrench to the specified torque.

Tightening torque:

21 N·m (2.1 kgf·m, 15 ft·lb)

NOTE:

- Be sure to place the gasket between the cylinder head and spark plug.
- If torque wrench is not available, tighten spark plug until gasket contacts cylinder head; then tighten further 1/4 to 1/2 turns.

2. 3.0 L MODEL

- 1) Disconnect battery cables and then remove battery and battery carrier.
- 2) Remove washer tank and put it aside.
- 3) Remove air cleaner lower case.
- 4) Disconnect connector from ignition coil.
- 5) Remove ignition coil.

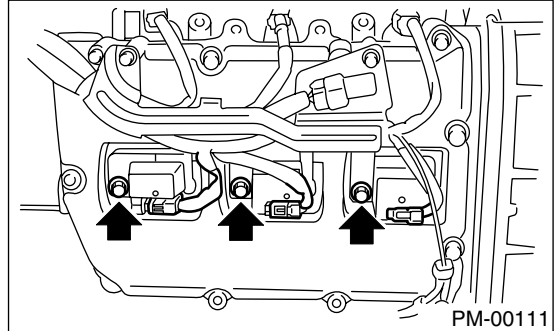

- 6) Remove spark plug with a spark plug socket.

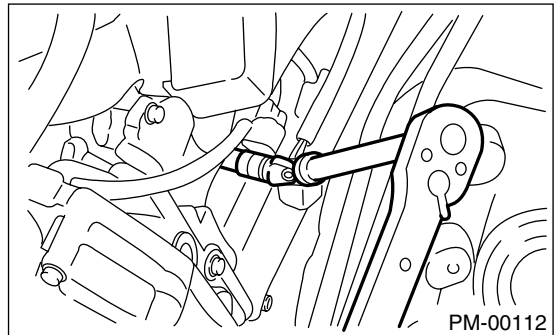

- 7) Set new spark plug.

Recommended spark plug:

NGK PLFR 6A-11

- 8) Tighten spark plug lightly with hand, and then secure with a plug-wrench to the specified torque.

Tightening torque:

21 N·m (2.1 kgf·m, 15 ft·lb)

- 9) Tighten ignition coil.

Tightening torque:

16 N·m (1.6 kgf·m, 11.7 ft·lb)

NOTE:

- Be sure to place the gasket between the cylinder head and spark plug.
- If torque wrench is not available, tighten spark plug until gasket contacts cylinder head: then tighten further 1/4 to 1/2 turn.

6. Drive Belt(s)

A: INSPECTION

1. 2.5 L MODEL

Without belt tension gauge

- 1) Replace belts, if cracks, fraying or wear is found.
- 2) Check drive belt tension and adjust it if necessary by changing generator installing position and/or idler pulley installing position.

Belt tension

(A)

New belt: 7.0 — 9.0 mm (0.276 — 0.354 in)

Reused: 9.0 — 11.0 mm (0.354 — 0.433 in)

(B)*

New belt: 7.5 — 8.5 mm (0.295 — 0.335 in)

Reused: 9.0 — 10.0 mm (0.354 — 0.394 in)

*: There is no belt (B) on models without an air conditioner.

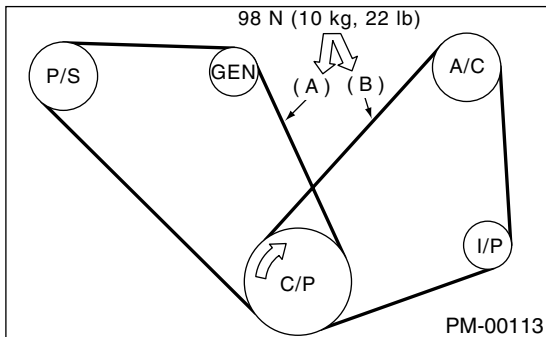

- C/P Crankshaft pulley
- GEN Generator
- P/S Power steering oil pump pulley
- A/C Air conditioning compressor pulley
- I/P Idler pulley

2. 2.5 L MODEL

With belt tension gauge

- 1) Replace belts, if cracks, fraying or wear is found.
- 2) Check drive belt tension and adjust it if necessary by changing generator installing position.

Belt tension

(A) 490 — 640 N (50 — 65 kgf, 110 — 144 lb)

(B) 350 — 450 N (36 — 46 kgf, 79 — 101 lb)

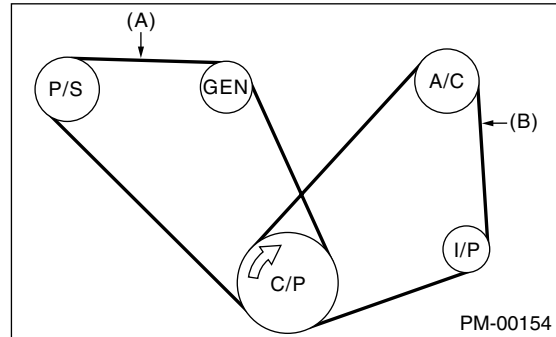

- C/P Crankshaft pulley
- GEN Generator
- P/S Power steering oil pump pulley
- A/C Air conditioning compressor pulley
- I/P Idler pulley

3. 3.0 L MODEL

- 1) Replace belts, if cracks, fraying or wear is found.
- 2) Check that the V-belt automatic tensioner indicator is within the range (D).

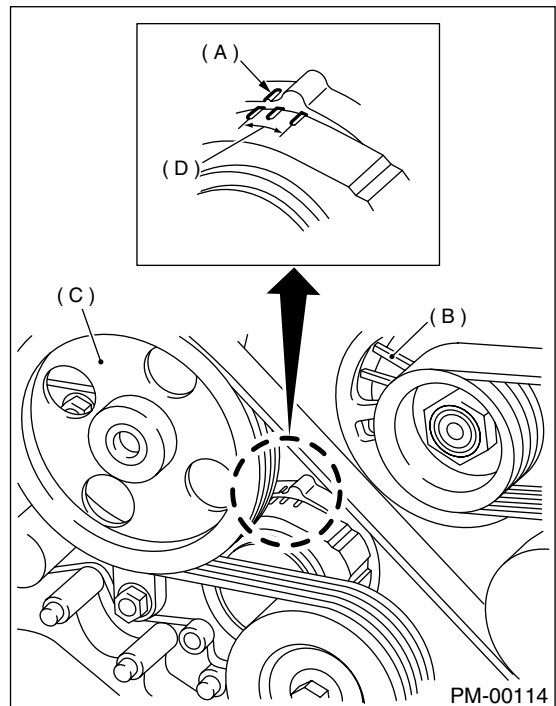

- (A) Indicator
- (B) Generator
- (C) Power steering oil pump
- (D) Service limit

DRIVE BELT(S)

PERIODIC MAINTENANCE SERVICES

B: REPLACEMENT

1. 2.5 L MODEL

1) Remove V-belt cover.

Non-TURBO model

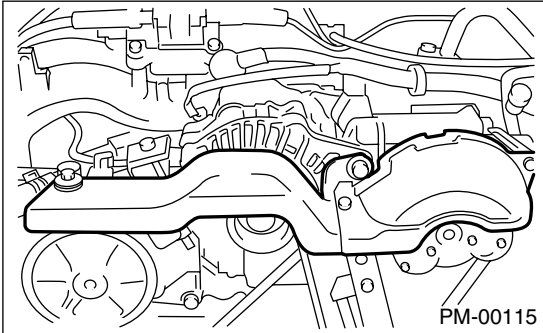

TURBO model

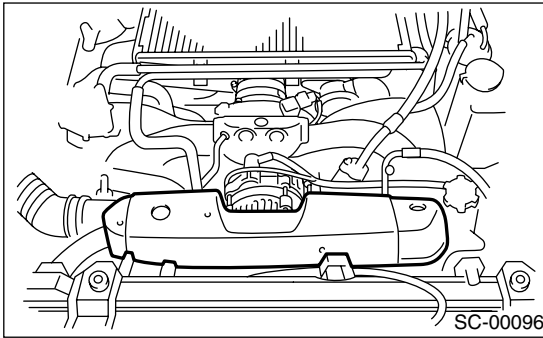

NOTE:

Wipe off any oil or water on the belt and pulley.

- 2) Loosen the lock bolt (A).
- 3) Loosen the slider bolt (B).
- 4) Remove the front side belt (C).

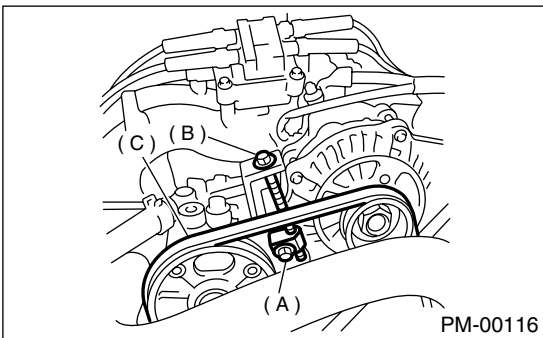

- 5) Loosen the lock nut (A).
- 6) Loosen the slider bolt (B).

7) Remove the rear side belt (C).

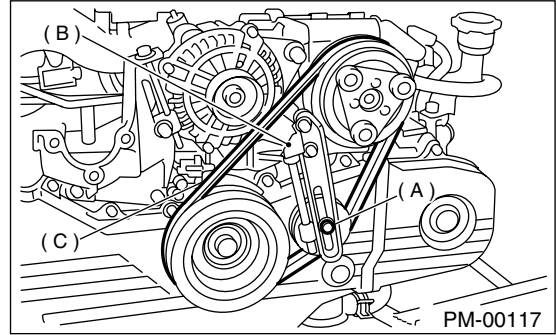

- 8) Install a new belt, and tighten the slider bolt so as to obtain the specified belt tension.
- 9) Tighten the slider bolt (B).
- 10) Tighten the lock nut (A).

Tightening torque:

22.6 N·m (2.3 kgf-m, 16.6 ft-lb)

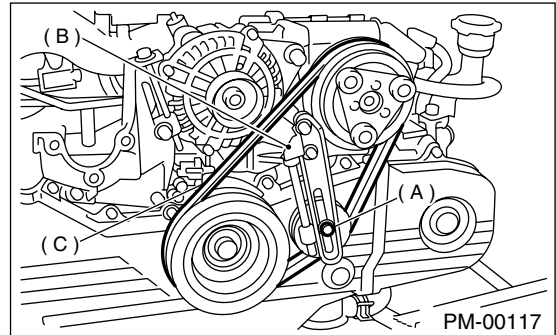

- 11) Install a new belt, and tighten the slider bolt so as to obtain the specified belt tension.
- 12) Tighten the lock bolt (A).
- 13) Tighten the slider bolt (B).

Tightening torque:

Lock bolt, through bolt:

25 N·m (2.5 kgf-m, 18 ft-lb)

Slider bolt:

8 N·m (0.8 kgf-m, 5.8 ft-lb)

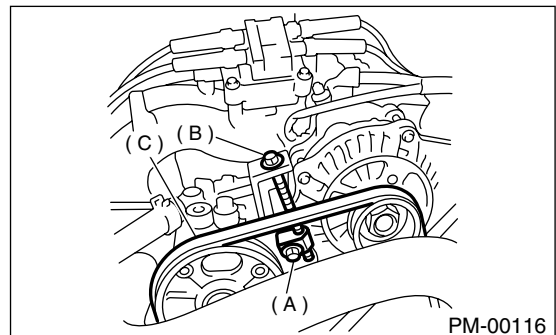

14) Install V-belt cover.

2. 3.0 L MODEL

- 1) Fit the tool to the belt tensioner mounting bolt.
- 2) Turn the tool clockwise, and loosen the V-belt to remove.

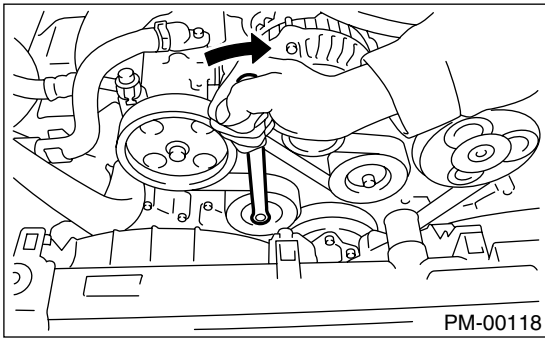

- 3) Install in the reverse order of removal.

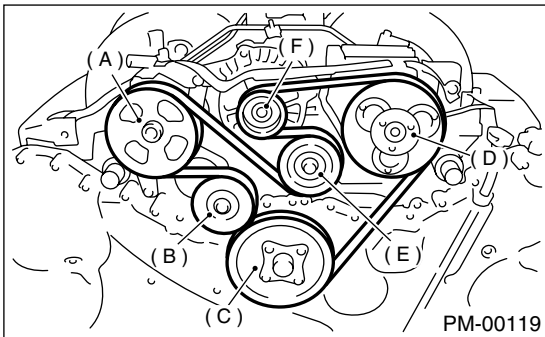

- (A) Power steering oil pump
- (B) Belt tension adjuster
- (C) Crankshaft pulley
- (D) A/C compressor
- (E) Belt idler
- (F) Generator

CAMSHAFT DRIVE BELT

PERIODIC MAINTENANCE SERVICES

7. Camshaft Drive Belt

A: REPLACEMENT

1. NON-TURBO MODEL

- 1) Remove radiator fan. <Ref. to CO(H4SO)-25, Radiator Main Fan and Fan Motor.> and <Ref. to CO(H4SO)-27, Radiator Sub Fan and Fan Motor.>
- 2) Remove V-belt cover.

Non-TURBO model

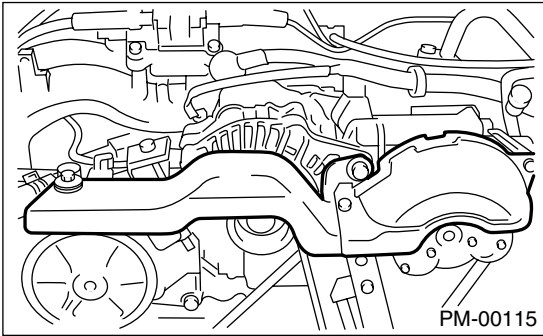

TURBO model

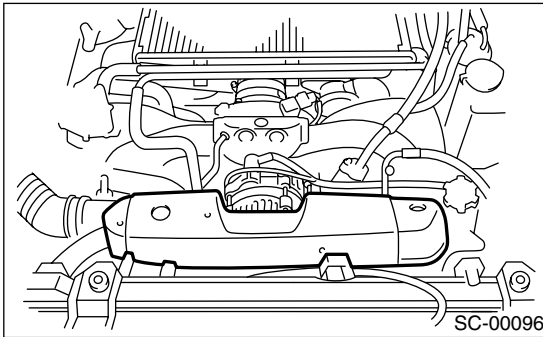

- 3) Remove V-belts. <Ref. to ME(H4SO)-43, V-belt.>
- 4) Remove air conditioning compressor drive belt tensioner.
- 5) Remove pulley bolt. To lock crankshaft use ST. ST 499977100 CRANKSHAFT PULLEY WRENCH

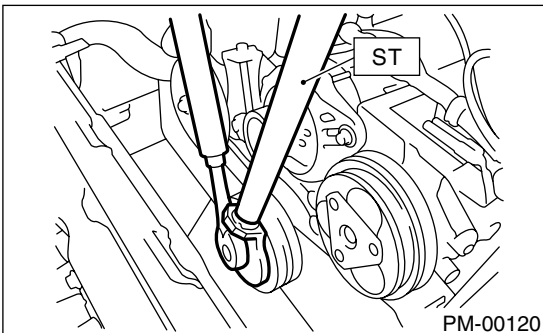

- 6) Remove crankshaft pulley.
- 7) Remove left side belt cover.
- 8) Remove front belt cover.

- 9) Turn crankshaft and align alignment marks on crankshaft, and left and right camshaft sprockets with notches of belt cover and cylinder block: ST 499987500 CRANKSHAFT SOCKET

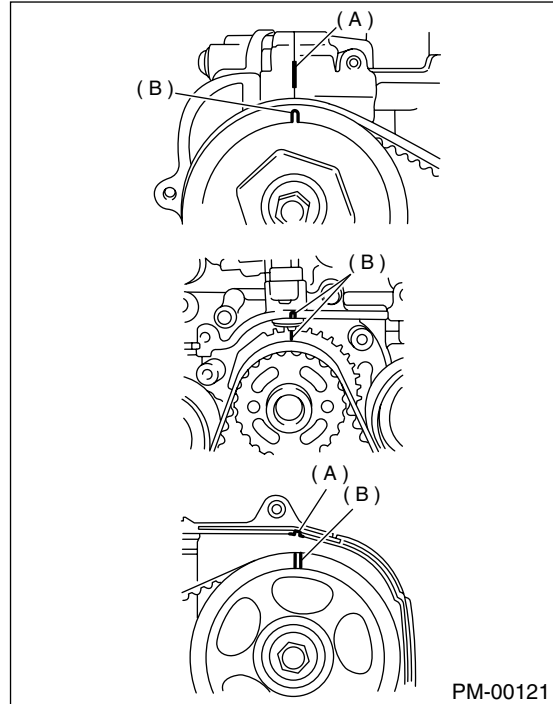

- (A) Notch
- (B) Alignment mark

- 10) Remove belt idler.
- 11) Remove belt idler (No. 2).

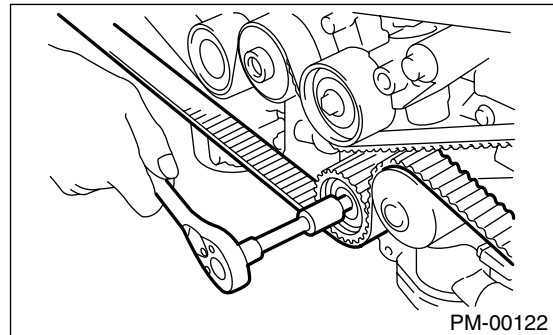

CAMSHAFT DRIVE BELT

PERIODIC MAINTENANCE SERVICES

- 12) Remove timing belt.
- 13) Remove automatic belt tension adjuster assembly.

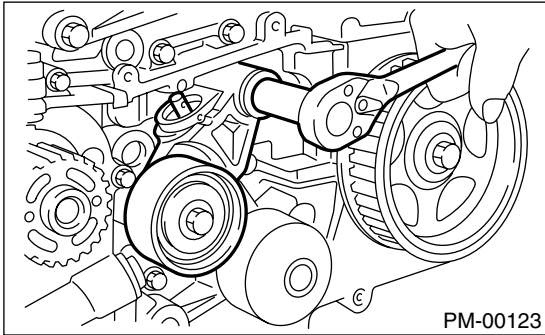

- 11) Turn the crankshaft and align the alignment marks on crankshaft, and left and right camshaft sprockets with notches of belt cover and cylinder block. To turn the crankshaft, use ST:
ST 499987500 CRANKSHAFT SOCKET

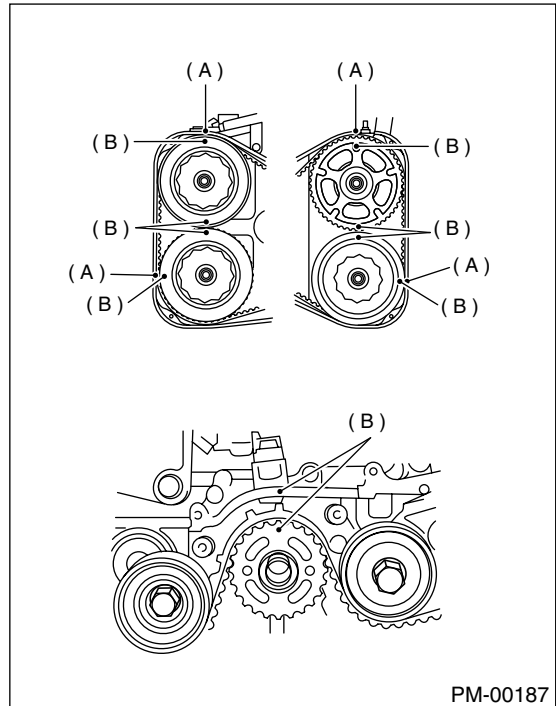

2. TURBO MODEL

- 1) Remove the radiator fan and air conditioner fan. <Ref. to CO(H4SO)-25, Radiator Main Fan and Fan Motor.>, <Ref. to CO(H4SO)-27, Radiator Sub Fan and Fan Motor.>
- 2) Use cardboard and blanket to protect the radiator.
- 3) Remove the V-belts. <Ref. to ME(H4SO)-43, V-belt.>
- 4) Remove the air conditioning compressor drive belt tensioner.
- 5) Remove the pulley bolt. To lock the crankshaft use ST.

ST 499977100 CRANKSHAFT PULLEY WRENCH

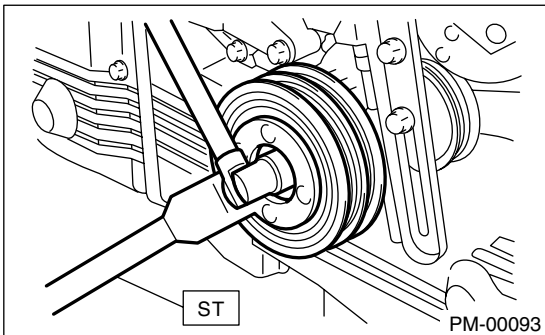

- (A) Notch
(B) Alignment mark

- 12) Remove the belt idler.

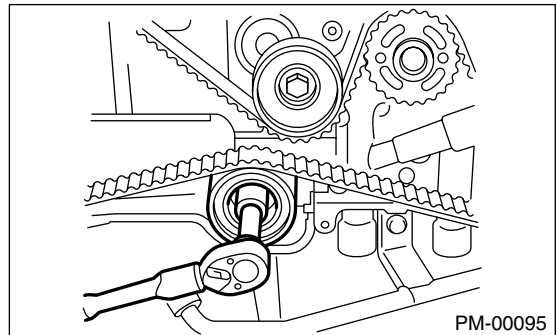

- 6) Remove the crankshaft pulley.
- 7) Remove the air conditioning compressor drive belt tensioner.
- 8) Remove the left side belt cover.
- 9) Remove the right side belt cover.
- 10) Remove the front belt cover.

- 13) Remove the timing belt.

CAMSHAFT DRIVE BELT

PERIODIC MAINTENANCE SERVICES

14) Remove the automatic belt tension adjuster assembly.

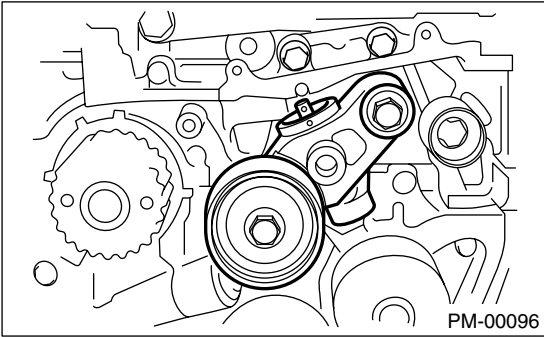

15) Install in the reverse order of removal.
<Ref. to ME(H4SO)-43, V-belt.>

CAUTION:

When installing the timing belt, be sure to align all alignment marks on the belt with corresponding marks on the sprockets.

B: INSTALLATION

Install in the reverse order of removal.

NOTE:

When installing the timing belt, be sure to align all alignment marks on the belt with corresponding marks on the sprockets. If incorrectly installed, interference between pistons and valves may occur.

C: INSPECTION

1. NON-TURBO MODEL

- 1) Remove front timing belt cover and timing belt cover (LH).
- 2) While cranking engine at least four rotations, check timing belt back surface for cracks or damage. Replace faulty timing belt as needed.
- 3) Measure timing belt width W . If it is less than 27 mm (1.06 in), check idlers, tensioner, water pump pulley and cam sprocket to determine idler alignment (squareness). Replace worn timing belt.

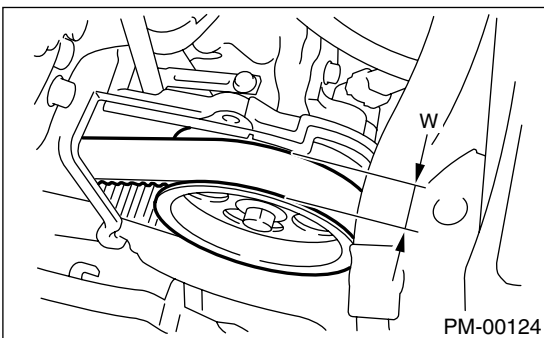

4) Install front timing belt cover and timing belt cover (LH).

2. TURBO MODEL

- 1) Remove the timing belt cover (LH).
- 2) While cranking the engine at least four rotations, check the timing belt back surface for cracks or damage. Replace the faulty timing belt as needed.
- 3) Measure the timing belt width W . If it is less than 30 mm (1.18 in), check the idlers, tensioner, water pump pulley and cam sprocket to determine idler alignment (squareness). Replace the worn timing belt.
- 4) Install the timing belt cover (LH).

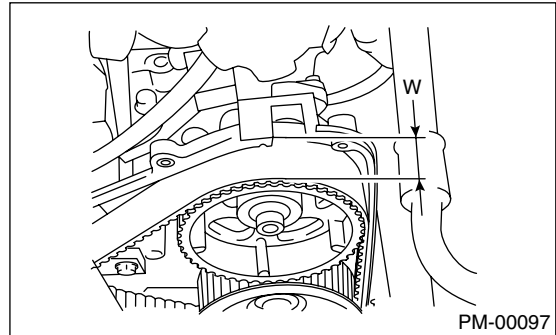

8. Fuel Line

A: INSPECTION

The fuel line is located mostly internally, so check pipes, areas near pipes, and engine compartment piping for rust, hose damage, loose bands, etc. If faulty parts are found, repair or replace them. <Ref. to FU(H4SO)-72, Fuel Delivery, Return and Evaporation Lines.> or <Ref. to FU(H6DO)-75, Fuel Delivery, Return and Evaporation Lines.>

FUEL FILTER

PERIODIC MAINTENANCE SERVICES

9. Fuel Filter

A: REPLACEMENT

WARNING:

- Place “NO FIRE” signs near the working area.
- Be careful not to spill fuel on the floor.

NOTE:

The fuel filter is built in fuel pump assembly.

- 1) Release the fuel pressure.
<Ref. to FU(H4SO)-48, OPERATION, Fuel.>
- 2) Remove the fuel pump assembly.
<Ref. to FU(H4SO)-66, REMOVAL, Fuel Pump.>
- 3) Disconnect the ground cable from filter holder.

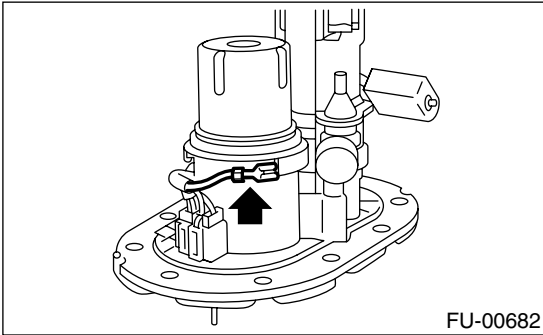

- 4) Remove the filter holder by turning it to the left from the body pawls, and then take out the filter.

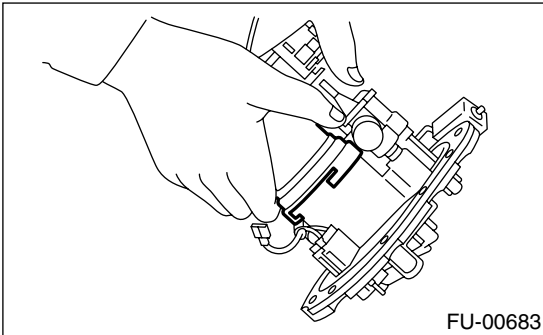

B: INSTALLATION

CAUTION:

- If the fuel hoses are damaged at the connecting portion, replace it with a new one.
- If the clamps are badly damaged, replace with new ones.
- Replace the o-ring with new ones.

- 1) Set the O-ring on the filter holder, and then install by turning to the right.

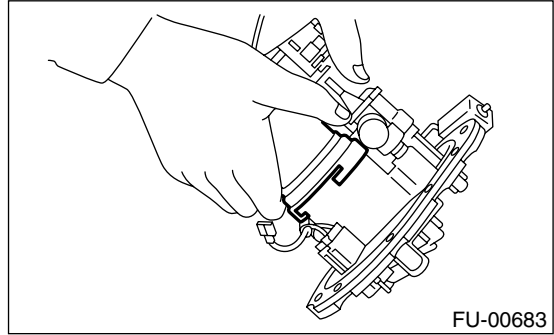

- 2) Connect the ground cable to filter holder.

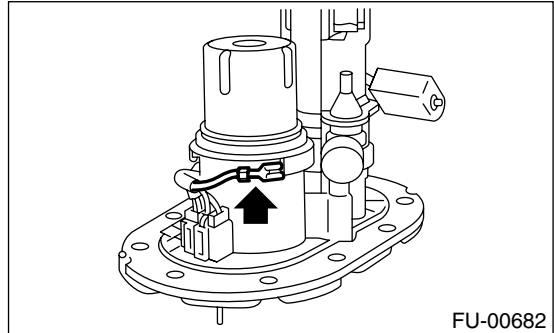

- 3) Install the fuel pump assembly.
<Ref. to FU(H4SO)-67, INSPECTION, Fuel Pump.>

C: INSPECTION

- 1) Check the inside of fuel filter for dirt and water sediment.
- 2) If it is clogged, or if replacement interval has been reached, replace it.

10. Air Cleaner Element

A: REPLACEMENT

1. 2.5 L NON-TURBO MODEL

Do not attempt to clean the air cleaner element. The filter paper of the element is wetted with a special non-inflammable slow-evaporating viscous liquid. It is resistant to cold weather and has a long service life. Dirt adhering to this filter paper forms porous laminations with the viscous liquid, which function as a filtration layer to reduce dust penetration into the filter paper. If this filter paper is cleaned, the filtration layer thus formed will be lost along with the viscous liquid.

- 1) Remove the air intake duct from air cleaner case.
- 2) Remove the bolt (A) which installs air cleaner case to stays.
- 3) Remove the clip (B) above the air cleaner case.

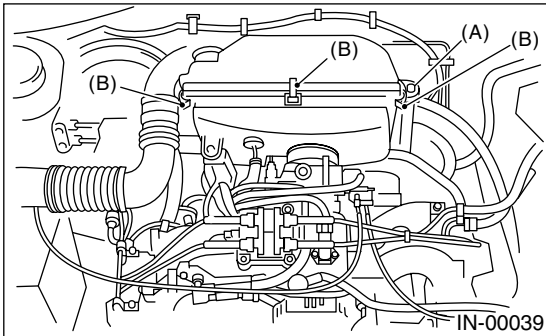

- 4) Remove the air cleaner element.

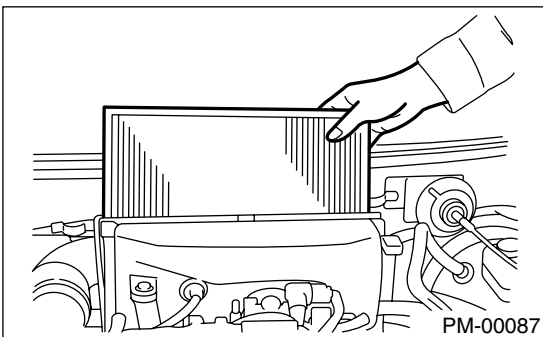

- 5) Install in the reverse order of removal.

CAUTION:
Fasten with a clip after inserting the lower tab of the case.

2. 2.5 L TURBO MODEL

- 1) Remove the clip (B) above the air cleaner upper cover.

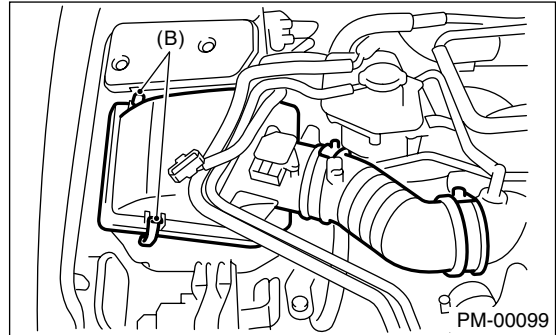

- 2) Remove air cleaner.

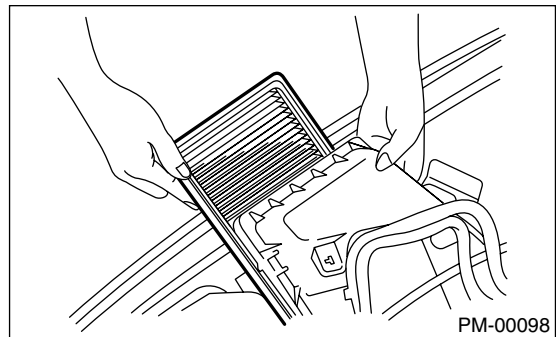

- 3) Install in the reverse order of removal.

CAUTION:
Align protruding portions of air cleaner upper cover with holes of air cleaner lower case, then secure upper cover to lower case.

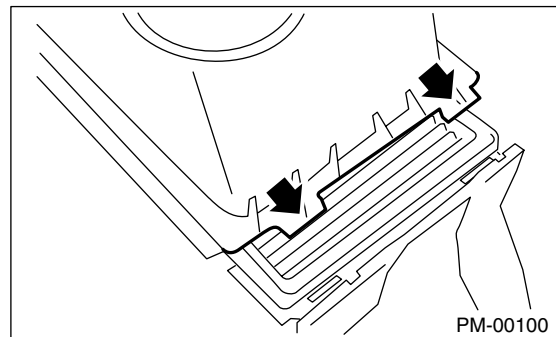

AIR CLEANER ELEMENT

PERIODIC MAINTENANCE SERVICES

3. 3.0 L MODEL

Do not attempt to clean the air cleaner element. The filter paper of the element is wetted with a special non-flammable slow-evaporating viscous liquid. It is resistant to cold weather and has a long service life. Dirt adhering to this filter paper forms porous laminations with the viscous liquid, which function as a filtration layer to reduce dust penetration into the filter paper. If this filter paper is cleaned, the filtration layer thus formed will be lost along with the viscous liquid.

- 1) Loosen clamp (A), and separate air cleaner upper cover and air intake boot.
- 2) Remove the clip (B) above the air cleaner upper cover.

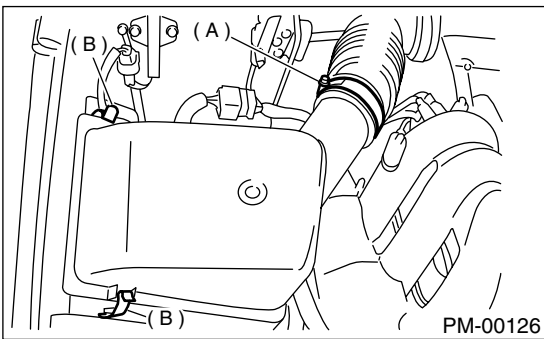

- 3) Remove air cleaner element.
- 4) Install in the reverse order of removal.

CAUTION:

Before installing air cleaner upper cover, align holes with protruding portions of air cleaner lower case, then secure upper cover to lower case.

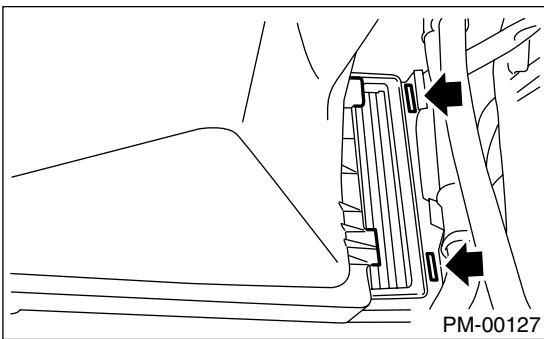

11. Cooling System

A: INSPECTION

1) Check radiator for leakage, filling it with coolant and attach radiator cap tester (A) to the filler neck. Then apply a pressure of 157 kPa (1.6 kg/cm², 23 psi) and check the following points:

- Each portion of radiator for leakage
- Hose joints and other connections for leakage

NOTE:

- When attaching or detaching tester and when operating tester, use special care not to deform radiator filler neck.

Non-TURBO model

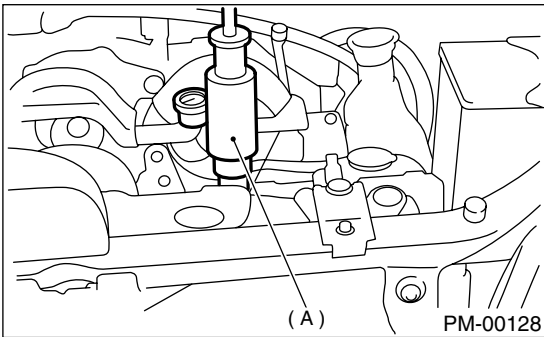

TURBO model

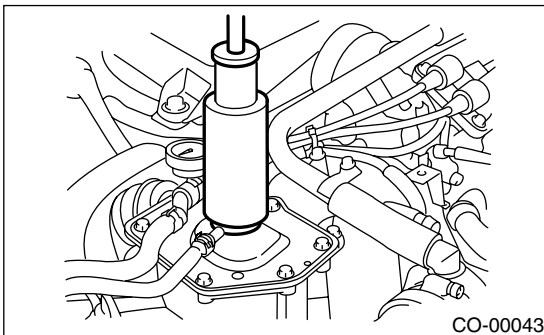

- When performing this check, be sure to keep the engine stationary and fill radiator with coolant.
- Wipe off check points before applying pressure.
- Use care not to spill coolant when detaching tester from radiator.

2) Check the radiator cap valve open pressure using radiator cap tester.

NOTE:

Rust or dirt on cap may prevent valve from functioning normally: be sure to clean cap before testing.

Raise the pressure until the needle of gauge stops and see if the pressure can be retained for five to six seconds. The radiator cap is normal if a pressure above the service limit value has been maintained for this period.

Radiator cap valve open pressure

Standard value:

93 — 123 kPa (0.95 — 1.25 kg/cm², 14 — 18 psi)

Service limit:

83 kPa (0.85 kg/cm², 12 psi)

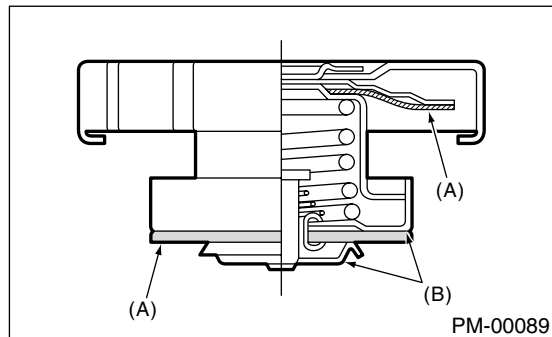
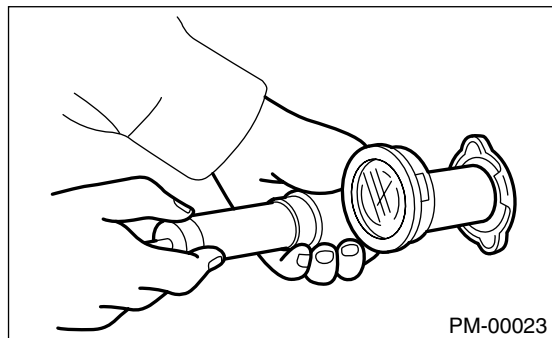

- (A) Check position for deformation
- (B) Check position for deformation, damage and rust.

3) If the coolant temperature exceeds 76.0 to 80.0°C (169 to 176°F) while radiator is not so hot, check thermostat. If thermostat does not open at 76.0 to 80.0°C (169 to 176°F), replace it with a new one.

4) If electric fan does not operate when coolant temperature exceeds 95°C (203°F), check the electric fan system.

12. Coolant

A: REPLACEMENT

1. REPLACEMENT OF COOLANT

WARNING:

The radiator is of the pressurized type. Do not attempt to open the radiator cap immediately after the engine has been stopped.

- 1) Lift up the vehicle.
- 2) Remove under cover.
- 3) Place a container under drain pipe.
- 4) Loosen and remove drain screw to drain engine coolant into container.

2.5 L model

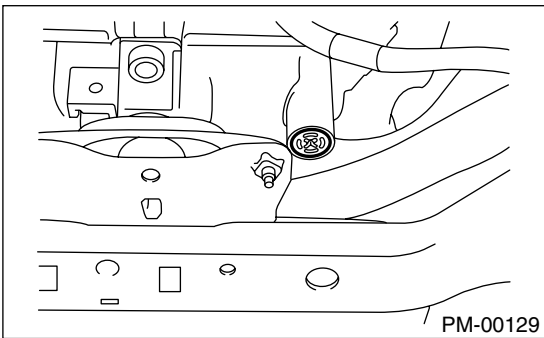

3.0 L model

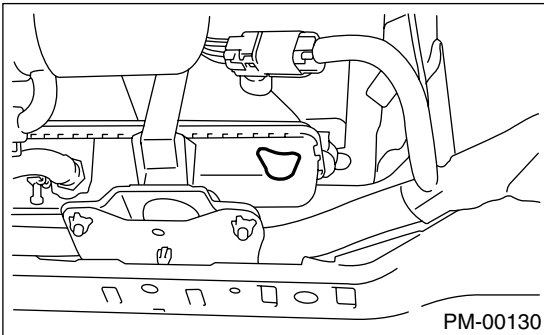

- 5) For quick draining, open radiator cap.

CAUTION:

Be careful not to spill coolant on the floor.

- 6) Drain coolant from reservoir tank.
- 7) Tighten radiator drain screw securely after draining coolant.

- 8) Slowly pour prepared coolant from radiator filler port to neck of filler, then pour into reservoir tank up to "FULL" level.

Coolant amount for preparation

2.5 L Non-TURBO model

MT model:

Approx. 6.8 ℓ (7.2 US qt, 6.0 Imp qt)

AT model:

Approx. 6.7 ℓ (7.1 US qt, 5.9 Imp qt)

2.5 L TURBO model

MT model:

Approx. 7.4 ℓ (7.8 US qt, 6.5 Imp qt)

AT model:

Approx. 7.3 ℓ (7.7 US qt, 6.4 Imp qt)

3.0 L model

Approx. 7.9 ℓ (8.4 US qt, 7.0 Imp qt)

NOTE:

The SUBARU Genuine Coolant containing anti-freeze and anti-rust agents is especially made for SUBARU engine, which has an aluminum crankcase. Always use SUBARU Genuine Coolant, since other coolant may cause corrosion.

- 9) Securely install radiator cap.

- 10) Run engine for more than five minutes at 2,000 to 3,000 rpm. (Run engine until radiator becomes hot in order to purge air trapped in cooling system.)

- 11) Stop engine and wait until coolant temperature lowers. Then open radiator cap to check coolant level and add coolant up to radiator filler neck. Next, add coolant into reservoir tank up to "FULL" level.

- 12) After adding coolant, securely install radiator and reservoir tank caps.

2. RELATIONSHIP OF SUBARU COOLANT CONCENTRATION AND FREEZING TEMPERATURE

The concentration and safe operating temperature of the SUBARU coolant is shown in the diagram. Measuring the temperature and specific gravity of the coolant will provide this information.

[Example]

If the coolant temperature is 25°C (77°F) and its specific gravity is 1.054, the concentration is 35% (point A), the safe operating temperature is -14°C (7°F) (point B), and the freezing temperature is -20°C (-4°F) (point C).

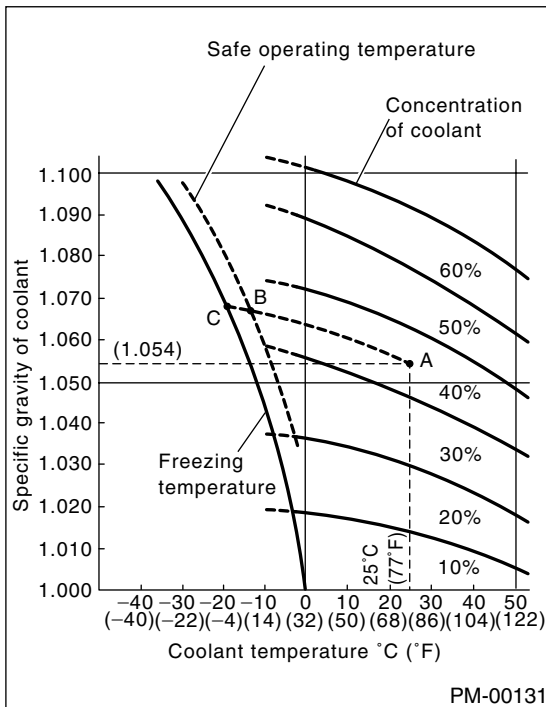

3. PROCEDURE TO ADJUST THE CONCENTRATION OF THE COOLANT

To adjust the concentration of the coolant according to temperature, find the proper fluid concentration in the above diagram and replace the necessary amount of coolant with an undiluted solution of SUBARU genuine coolant (concentration 50).

The amount of coolant that should be replaced can be determined using the diagram.

[Example]

Assume that the coolant concentration must be increased from 25% to 40%. Find point A, where the 25% line of coolant concentration intersects with the 40% curve of the necessary coolant concentration, and read the scale on the vertical axis of the graph at height A. The quantity of coolant to be drained is 2.1 liters (2.2 US qt, 1.8 Imp qt). Drain 2.1 liters (2.2 US qt, 1.8 Imp qt) of coolant from the cooling system and add 2.1 liters (2.2 US qt, 1.8 Imp qt) of the undiluted solution of SUBARU coolant.

If a coolant concentration of 50% is needed, drain all the coolant and refill with the undiluted solution only.

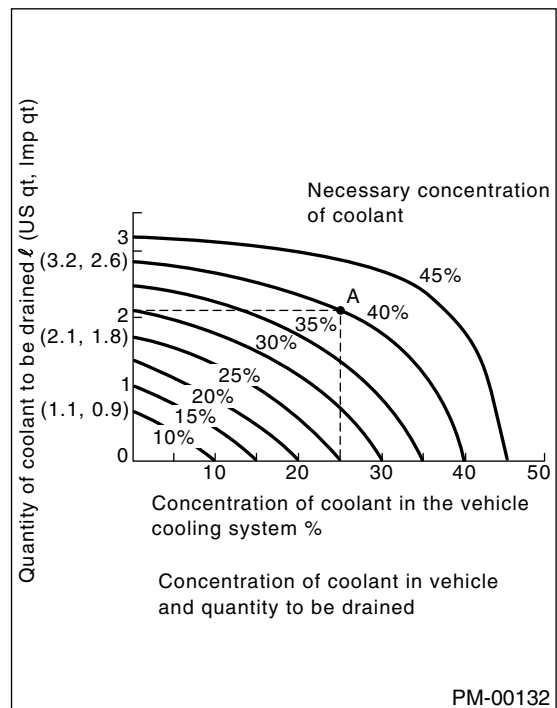

CLUTCH SYSTEM

PERIODIC MAINTENANCE SERVICES

13. Clutch System

A: INSPECTION AND ADJUSTMENT

1) Push the release lever to retract the push rod of the operating cylinder and check if the fluid level in the clutch reservoir tank rises or not.

Non-TURBO model

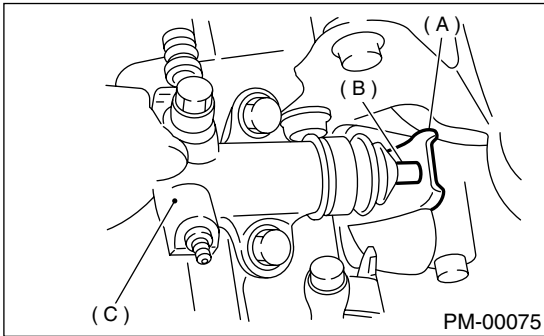

- (A) Release lever
- (B) Push rod
- (C) Operating cylinder

TURBO model

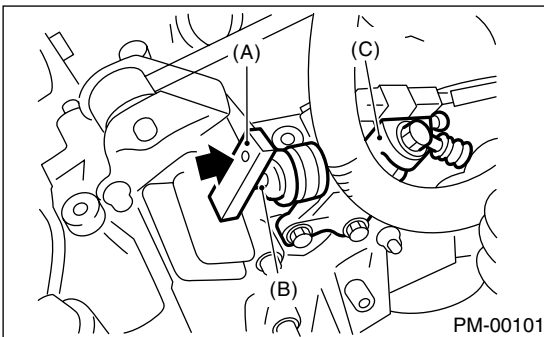

- (A) Release lever
- (B) Push rod
- (C) Operating cylinder

2) If the fluid level rises, pedal free play is correct.
3) If the fluid level does not rise, or the push rod cannot be retracted, adjust the clutch pedal. <Ref. to CL-28, Clutch Pedal.>
4) Inspect the underside of master cylinder, clutch damper and operating cylinder for clutch system, hoses, piping and their couplings for fluid leaks. If fluid leaks are found, correct them by retightening their fitting bolt and/or replacing their parts.

5) Check the fluid level using the scale on the outside of the clutch master cylinder tank (A). If the level is below "MIN" (B), add clutch fluid to bring it up to "MAX" (C).

Recommended clutch fluid:

FMVSS No. 116, fresh DOT3 or DOT4 brake fluid

NOTE:

- Avoid mixing different grades of brake fluid to prevent degradation of the fluid.
- Be careful not to allow dirt or dust to get into the reservoir tank.

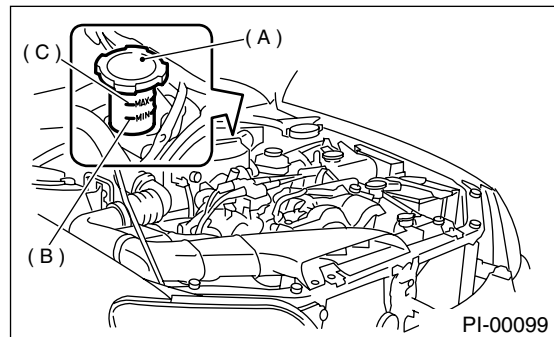

- (A) Reservoir tank
- (B) MIN. level
- (C) MAX. level

14. Transmission Oil

A: REPLACEMENT

1. MANUAL TRANSMISSION

1) Drain gear oil by removing drain plug after allowing the engine to cool for 3 to 4 hours.

NOTE:

- Before starting work, cool off the engine well.
- If transmission gear oil splashes on exhaust pipe, wipe it clean.

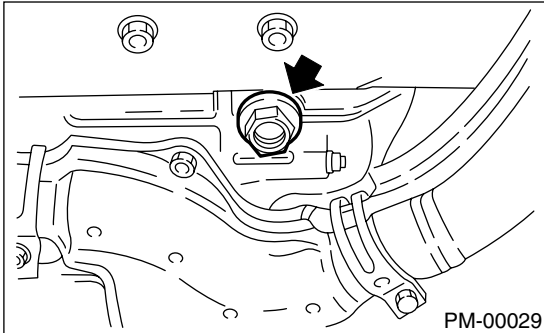

2) Reinstall drain plug after draining gear oil and tighten it to the specified torque.

Tightening torque:

44 N·m (4.5 kgf-m, 32.5 ft-lb)

NOTE:

- Replace the gasket with a new one.
 - Each oil manufacturer has its base oil and additives. Thus, do not mix two or more brands.
- 3) Fill transmission gear oil through the oil level gauge up to the upper point of level gauge.

Gear oil capacity:

3.5 ℓ (3.7 US qt, 3.1 Imp qt)

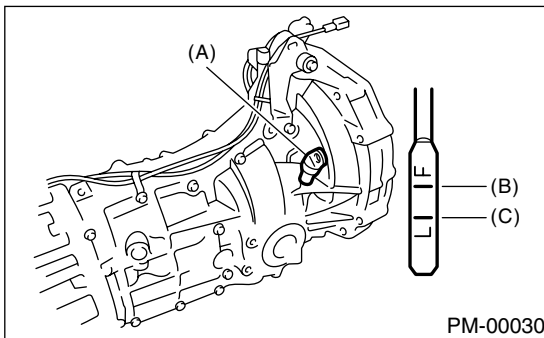

- (A) Oil level gauge
- (B) Upper level
- (C) Lower level

15.ATF

A: INSPECTION

1) Raise ATF temperature to 70 to 80°C (158 to 176°F) from 20 to 30°C (68 to 86°F) (when cold) by driving a distance of 5 to 10 km (3 to 6 miles).

NOTE:

The level of ATF varies with fluid temperature. Pay attention to the fluid temperature when checking oil level.

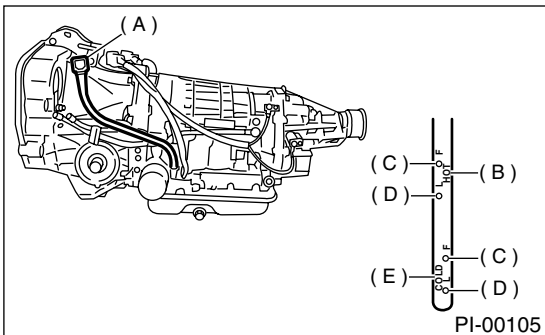

- (A) Level gauge
- (B) Check line, HOT condition
- (C) Upper level
- (D) Lower level
- (E) Check line, COLD condition

2) Make sure the vehicle is level. After selecting all positions (P, R, N, D, 3, 2, 1), set the select lever in "P" range. Measure fluid level with the engine idling.

NOTE:

After running, idle the engine for one or two minutes before measurement.

3) If the fluid level is below the center between upper and lower marks, add the recommended ATF until the fluid level is found within the specified range (above the center between upper and lower marks). When the transmission is hot, the level should be above the center of upper and lower marks, and when it is cold, the level should be found below the center of these two marks.

CAUTION:

- Use care not to exceed the upper limit level.
- ATF level varies with temperature. Remember that the addition of fluid to the upper limit mark when the transmission is cold will result in the overfilling of fluid.

4) Fluid temperature rising speed

- By idling the engine

Time for temperature rise to 60°C (140°F) with atmospheric temperature of 0°C (32°F): More than 25 minutes

<Reference>

Time for temperature rise to 30°C (86°F) with atmospheric temperature of 0°C (32°F): Approx. 8 minutes

- By running the vehicle

Time for temperature rise to 60°C (140°F) with atmospheric temperature of 0°C (32°F): More than 10 minutes

5) Method for checking fluid level upon delivery or at periodic inspection

Check fluid level after a warm-up run of approx. 10 minutes. During the warm-up period, the automatic transmission functions can also be checked.

B: REPLACEMENT

1. AUTOMATIC TRANSMISSION FLUID

1) Drain ATF (Automatic Transmission Fluid) by removing drain plug after allowing the engine to cool for 3 to 4 hours.

NOTE:

Before starting work, cool off the engine well.

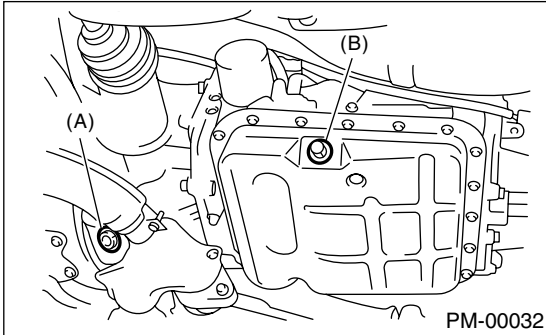

(A) Front differential drain plug

(B) ATF drain plug

2) Reinstall drain plug after draining ATF, and tighten it to the specified torque.

Tightening torque:

25 N·m (2.5 kgf-m, 18.1 ft-lb)

3) Pour ATF into the oil charge pipe.

Recommended fluid:

Dexron III type automatic transmission fluid

ATF amount:

Refill with the same amount of ATF that was drained.

4) Check the level of the ATF. Refer to "INSPECTION".

2. ATF FILTER

NOTE:

ATF filter is maintenance free part. ATF filter needs replacement, when it has physically damaged or ATF leaked.

For the replacement procedures of the ATF filter:
<Ref. to 4AT-77, ATF Filter.>

FRONT & REAR DIFFERENTIAL OIL

PERIODIC MAINTENANCE SERVICES

16. Front & Rear Differential Oil

A: REPLACEMENT

1. FRONT DIFFERENTIAL (MANUAL TRANSMISSION)

For M/T vehicle, manual transmission oil works as differential oil to lubricate differential. Refer to "Transmission Oil". <Ref. to PM-25, MANUAL TRANSMISSION, REPLACEMENT, Transmission Oil.>

2. FRONT DIFFERENTIAL (AUTOMATIC TRANSMISSION)

1) Drain differential gear oil by removing drain plug using TORX T70.

NOTE:

- Before starting work, cool off the engine well.
- If transmission gear oil splashes on exhaust pipe, wipe it clean.

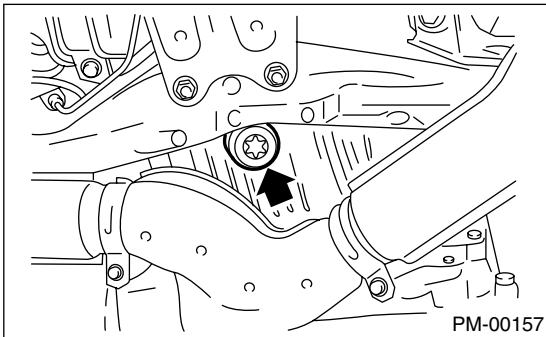

2) Reinstall drain plug after draining differential gear oil and tighten it to the specified torque.

Tightening torque:

70 N·m (7.1 kgf·m, 51.4 ft·lb)

NOTE:

- Be sure to place a gasket between the transmission case and drain plug.
 - Replace the gasket with a new one.
 - Each oil manufacturer has its base oil and additives. Thus, do not mix two or more brands.
- 3) Fill differential gear oil through the oil level gauge hole up to the upper point of level gauge.

Differential gear oil capacity:

1.1 — 1.3 ℓ (1.2 — 1.4 US qt, 1.0 — 1.1 Imp qt)

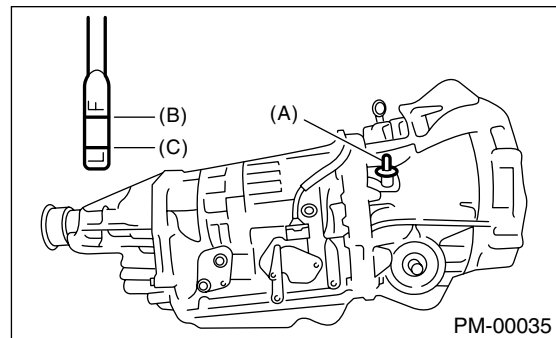

- (A) Oil level gauge
- (B) Upper level
- (C) Lower level

FRONT & REAR DIFFERENTIAL OIL

PERIODIC MAINTENANCE SERVICES

3. REAR DIFFERENTIAL

• AT model

- 1) Drain oil by removing drain plug.
- 2) Remove filler plug for quicker draining.
- 3) Replace drain plug gasket with a new one.
- 4) Tighten drain plug to the specified torque.

Tightening torque:

34 N·m (3.5 kgf-m, 25.3 ft-lb)

- 5) After installing drain plug, fill oil fully up to the mouth of filler plug.

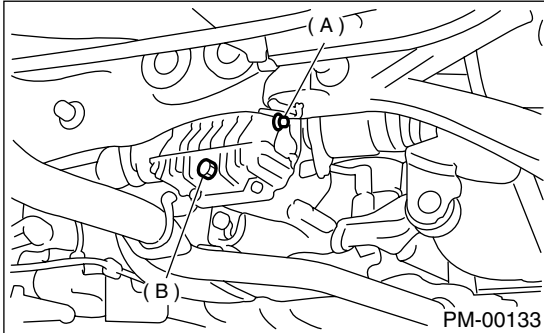

- (A) Filler plug
(B) Drain plug

Oil capacity:

0.8 ℓ (0.8 US qt, 0.7 Imp qt)

- 6) Replace filler plug gasket with a new one.
- 7) Install filler plug onto rear differential gear case.

Tightening torque:

34 N·m (3.5 kgf-m, 25.3 ft-lb)

• Except AT model

- 1) Drain oil by removing drain plug.
- 2) Remove filler plug for quicker draining.
- 3) Tighten drain plug after draining oil.

NOTE:

Apply fluid gasket to drain plug threads before installation.

Fluid gasket:

Three Bond 1105 (Part No. 004403010)

Tightening torque:

49.0 N·m (5.0 kgf-m, 36.2 ft-lb)

- 4) After installing drain plug onto rear differential gear case firmly, fill oil up fully to the mouth of filler plug.

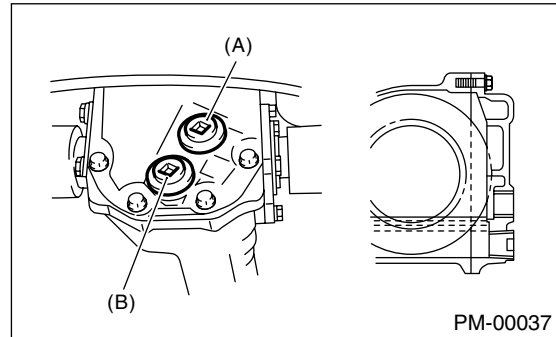

- (A) Filler plug
(B) Drain plug

Oil capacity:

0.8 ℓ (0.8 US qt, 0.7 Imp qt)

NOTE:

Each oil manufacturer has its base oil and additives. Thus, do not mix two or more brands.

- 5) Install filler plug onto rear differential gear case firmly.

NOTE:

Apply fluid packing to filler plug before installation.

Fluid packing:

Three Bond 1105 (Part No. 004403010)

Tightening torque:

49.0 N·m (5.0 kgf-m, 36.2 ft-lb)

BRAKE LINE

PERIODIC MAINTENANCE SERVICES

17. Brake Line

A: INSPECTION

1. BRAKE LINE

- 1) Check scratches, swelling, corrosion and/or traces of fluid leakage on brake hoses or pipe joints.
- 2) Check the possibility of adjacent parts interfering with brake pipes/hoses during driving, and loose connections/clamps.
- 3) Check any trace of fluid leakage, scratches, etc. on master cylinder, wheel cylinder and pressure control valve.

NOTE:

- When the brake fluid level in the reservoir tank is lower than the specified limit, the brake fluid warning light on the combination meter will come on.
- Visually check brake hose (using a mirror where it is difficult to see) for any damage.

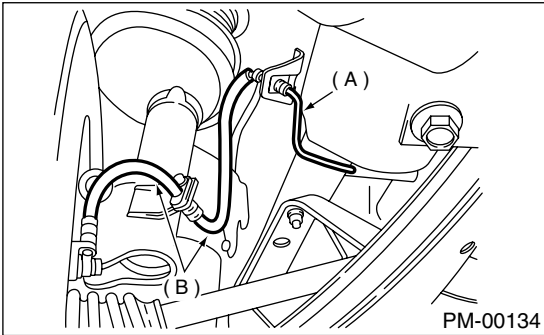

- (A) Front brake pipe
(B) Front brake hose

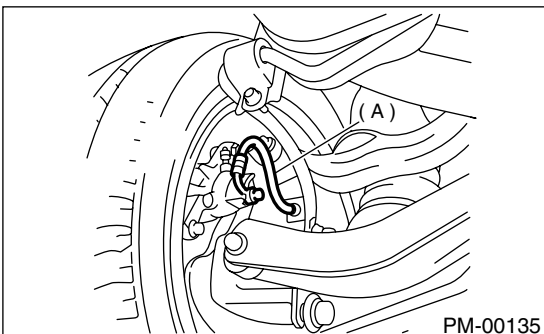

- (A) Rear brake hose

B: CHECKING

1. SERVICE BRAKE

- 1) Check the free play of brake pedal with a force of less than 10 N (1 kgf, 2 lb).

Brake pedal free play:

1 — 3 mm (0.04 — 0.12 in)

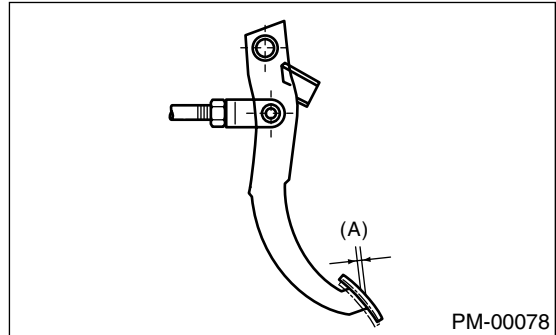

- (A) Pedal play

- 2) If the free play is out of specifications above, adjust the brake pedal as follows:

- (1) Be sure engine is off. (No vacuum is applied to brake booster.)
- (2) There should be play between brake booster clevis and pin at brake pedal installing portion.

[Depress brake pedal pad with a force of less than 10 N (1 kgf, 2 lb) to a stroke of 1 to 3 mm (0.04 to 0.12 in).]

- (3) Depress the surface of brake pad by hand.

(4) If there is no free play between clevis pin and clevis, turn brake switch adjusting nut until the clearance between stopper and screw of brake switch becomes 0.3 mm (0.012 in).

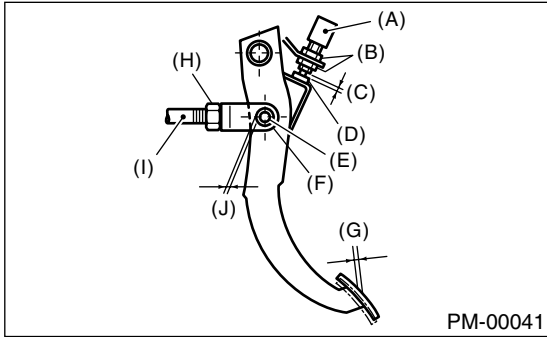

- (A) Brake switch
- (B) Adjusting nut
- (C) 0.3 mm (0.012 in)
- (D) Stopper
- (E) Clevis pin
- (F) Clevis
- (G) Pedal play
1 - 3 mm (0.04 - 0.12 in)
- (H) Lock nut
- (I) Brake booster operating nut
- (J) Play at pin

3) Check the pedal stroke.

While the engine is idling, depress the brake pedal with a 490 N (50 kgf, 110 lb) load and measure the distance between the brake pedal and steering wheel. With the brake pedal released, measure the distance between the pedal and steering wheel again. The difference between the two measurements must be less than 95 mm (3.74 in). If the distance is more than specified, there is a possibility air is in the inside of the hydraulic unit.

**Brake pedal reserve distance: A
less more than 95 mm (3.74 in)/ 490 N (50 kgf, 110 lb)**

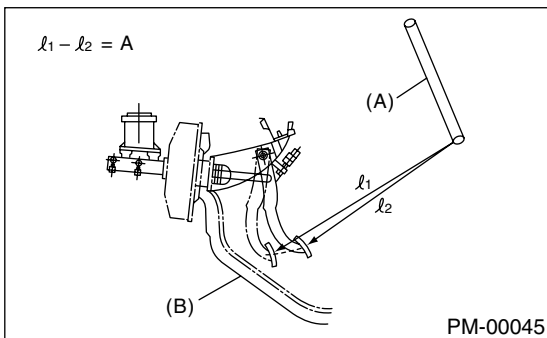

- (A) Steering wheel
- (B) Toe board

4) Check to see if air is in the hydraulic brake line by the feel of pedal operation. If air appears to exist in the line, bleed it from the system.

5) Check for even operation of all brakes, using a brake tester or by driving the vehicle for a short distance on a straight road.

2. BRAKE SERVO SYSTEM

1) With the engine off, depress the brake pedal several times applying the same pedal force: Make sure the travel distance should not change.

2) With the brake pedal depressed, start the engine: Make sure the pedal should move slightly toward the floor.

3) With the brake pedal depressed, stop the engine and keep the pedal depressed for 30 seconds: Make sure the pedal height should not change.

4) Check valve is built into vacuum hose. Disconnect vacuum hose to inspect function of check valve.

Blow air into vacuum hose from its brake booster side end: Air must flow out of engine side end of hose. Next blow air into hose from engine side: Air should not flow out of hose.

Replace both check valve and vacuum hose if check valve is faulty. Engine side of vacuum hose is indicated by marking "ENGINE" as shown.

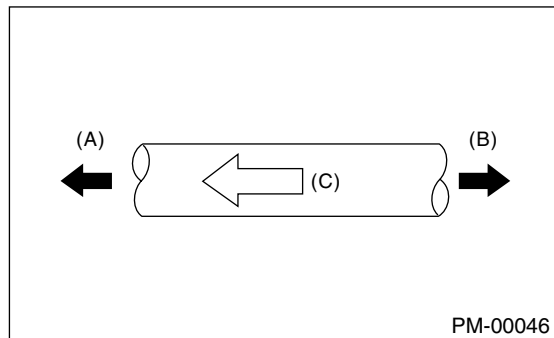

- (A) Engine side
- (B) Brake booster side
- (C) ENG

5) Check vacuum hose for cracks or other damage.

NOTE:

When installing the vacuum hose on the engine and brake booster, do not use soapy water or lubricating oil on their connections.

6) Check vacuum hose to make sure it is tight and secure.

BRAKE FLUID

PERIODIC MAINTENANCE SERVICES

18. Brake Fluid

A: REPLACEMENT

- 1) Either jack up vehicle and place a safety stand under it, or lift up vehicle.
- 2) Remove both front and rear wheels.
- 3) Draw out the brake fluid from master cylinder with syringe.
- 4) Refill reservoir tank with recommended brake fluid.

Recommended brake fluid:

FMVSS No. 116, fresh DOT3 or 4 brake fluid

NOTE:

- Avoid mixing different brands of brake fluid to prevent degrading the quality of the fluid.
- Be careful not to allow dirt or dust to get into the reservoir tank.

Bleeding sequence (1) → (2) → (3) → (4)

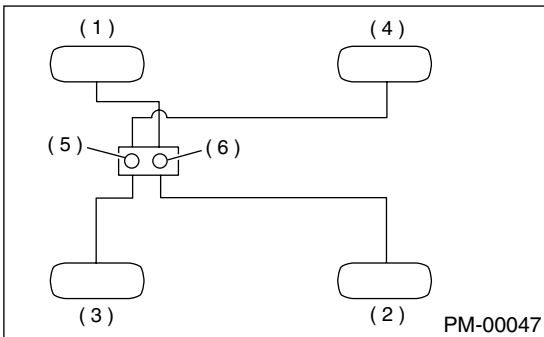

- (1) Front right
- (2) Rear left
- (3) Front left
- (4) Rear right
- (5) Secondary
- (6) Primary

- 5) Install one end of a vinyl tube onto the air bleeder and insert the other end of the tube into a container to collect the brake fluid.

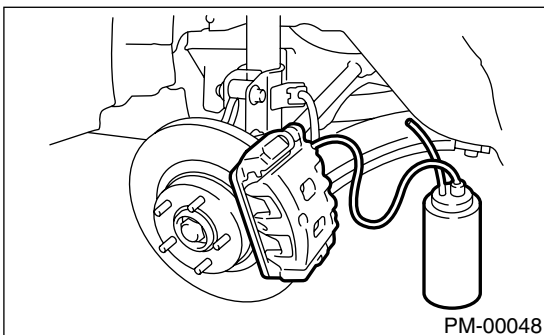

NOTE:

- Cover bleeder with waste cloth, when loosening it, to prevent brake fluid from being splashed over surrounding parts.
 - During bleeding operation, keep the brake reservoir tank filled with brake fluid to eliminate entry of air.
 - Brake pedal operation must be very slow.
 - For convenience and safety, it is advisable to have two men working.
 - The amount of brake fluid required is approximately 500 m^l (16.9 US fl oz, 17.6 Imp fl oz) for total brake system.
- 6) Instruct your co-worker to depress the brake pedal slowly two or three times and then hold it depressed.
 - 7) Loosen bleeder screw approximately 1/4 turn until a small amount of brake fluid drains into container, and then quickly tighten screw.
 - 8) Repeat steps 6) and 7) above until there are no air bubbles in drained brake fluid and new fluid flows through vinyl tube.

NOTE:

Add brake fluid as necessary while performing the air bleed operation, in order to prevent the tank from running short of brake fluid.

- 9) After completing the bleeding operation, hold brake pedal depressed and tighten screw and install bleeder cap.

Tightening torque:

8 N·m (0.8 kgf-m, 5.8 ft-lb)

- 10) Bleed air from each wheel cylinder by following the previous 5 steps.
- 11) Depress brake pedal with a force of approximately 294 N (30 kgf, 66 lb) and hold it there for approximately 20 seconds. At this time check pedal to see if it makes any unusual movement. Visually inspect bleeder screws and brake pipe joints to make sure that there is no fluid leakage.
- 12) Install wheels, and drive vehicle for a short distance between 2 to 3 km (1 to 2 miles) to make sure that brakes are operating properly.

19. Disc Brake Pads and Discs

A: INSPECTION

1. DISC BRAKE PAD AND DISC

- 1) Jack up vehicle and support with rigid racks. Then remove wheels.
- 2) Visually check pad thickness through inspection hole of disc brake assembly. Replace pad if necessary.

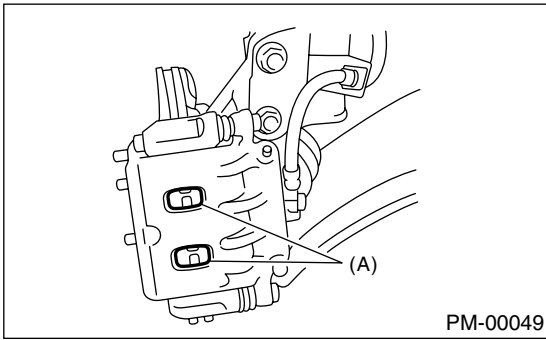

(A) Inspection hole

Pad thickness mm (in)		
	Front	Rear
Standard	11 (0.43)	9 (0.35)
Service limit	1.5 (0.059)	1.5 (0.059)

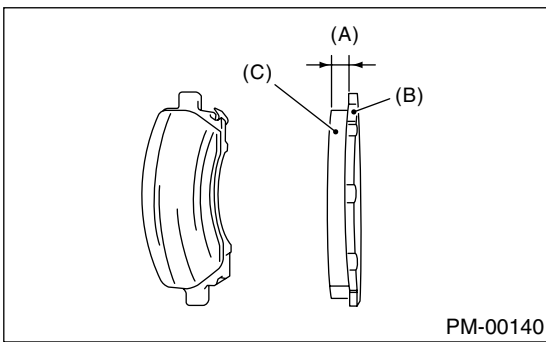

- (A) Thickness of pad
- (B) Back metal
- (C) Lining

- 3) Check the disc rotor, and correct or replace if it is damaged or worn.

Brake disc thickness mm (in)		
	Front	Rear
Standard	24 (0.94)	10 (0.39)
Wear limit	22 (0.87)	8.5 (0.335)

- 4) Measure the disc rotor runout at a point less than 10 mm (0.39 in) from the outer periphery of the rotor.

Disc rotor runout limit:

Front: 0.075 mm (0.0030 in)

Rear: 0.070 mm (0.0028 in)

NOTE:

When replacing a pad, always replace the pads for both the left and right wheels at the same time. Also replace pad clips if they are twisted or worn.

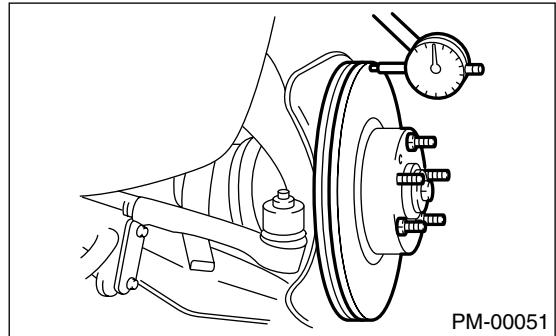

PARKING BRAKE

PERIODIC MAINTENANCE SERVICES

20. Parking Brake

A: INSPECTION

Inspect brake linings and drums of both sides of the rear brake at the same time by removing brake drums.

1) Inspect brake shoes for damage or deformation and check brake linings for wear.

NOTE:

Always replace both primary and secondary brake shoes for the left and right wheels at the same time.

Brake lining thickness excluding back metal

Standard value: 3.2 mm (0.126 in)

Wear limit: 1.5 mm (0.059 in)

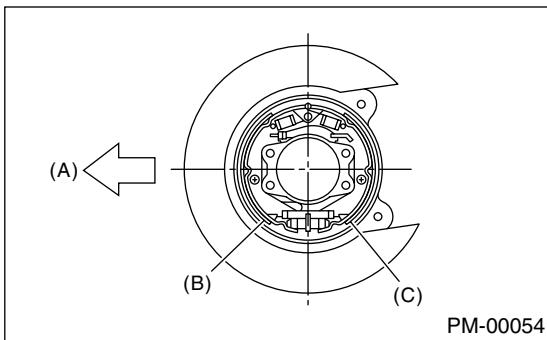

(A) Front

(B) Brake shoe (Primary)

(C) Brake shoe (Secondary)

2) Check brake drum for wear, dents or other damage. If the inside surface of brake drum is streaked, correct the surface with emery cloth (#200 or more). If it is unevenly worn, tapered, or the outside surface of brake drum is damaged, correct or replace it.

Brake drum inside diameter

Standard value: 170 mm (6.69 in)

Wear limit: 171 mm (6.73 in)

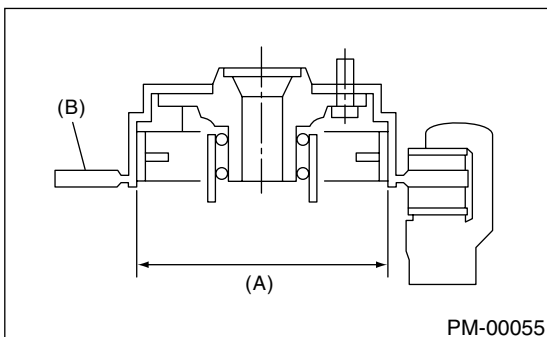

(A) Measuring inside diameter

(B) Disc

3) If the deformation or wear of back plate, shoe, etc. is noticeable, replace them.

4) When the shoe return spring tension is excessively weakened, replace it, taking care to identify upper and lower springs.

B: ADJUSTMENT

1. SHOE CLEARANCE

- 1) Remove adjusting hole cover from back plate.
- 2) Turn adjusting screw using a slot-type screwdriver until brake shoe is in close contact with disc rotor.

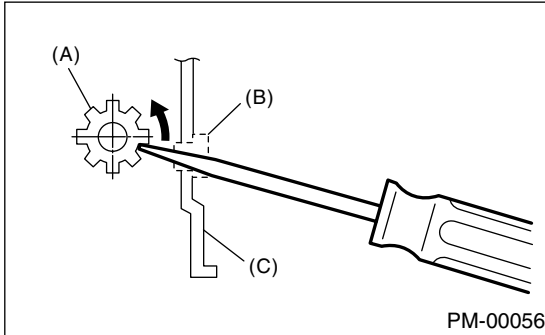

- (A) Adjusting screw
- (B) Cover (rubber)
- (C) Back plate

- 3) Turn back (downward) adjusting screw 3 or 4 notches.
- 4) Install adjusting hole cover to back plate.

2. LEVER STROKE

- 1) Remove console box lid.
- 2) Forcibly pull parking brake lever 3 to 5 times.
- 3) Adjust parking brake lever by turning adjuster until parking brake lever stroke is set at 6 notches with operating force of 196 N (20 kgf, 44 lb).

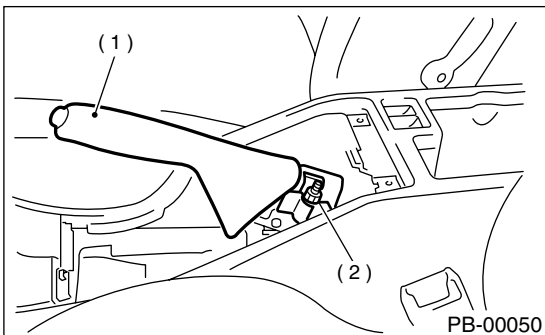

- (1) Parking brake lever
- (2) Adjusting nut (self-locking nut)

- 4) Install console box lid.

Lever stroke:

7 to 8 notches when pulled with a force of 196 N (20 kgf, 44 lb)

If self-locking nuts removed, replace them with new ones.

21. Suspension

A: INSPECTION

1. SUSPENSION BALL JOINT

- 1) Jack up vehicle until front wheels are off ground.
- 2) Next, grasp bottom of tire and move it in and out. If relative movement is observed between brake disc cover and end of transverse link, ball joint may be excessively worn.
- 3) Next, grasp end of transverse link and move it up and down. Relative movement between housing and transverse link boss indicates ball joint may be excessively worn.
- 4) If relative movement is observed in the immediately preceding two steps, remove and inspect ball joint. If free play exceeds standard, replace ball joint. <Ref. to FS-17, Front Ball Joint.>

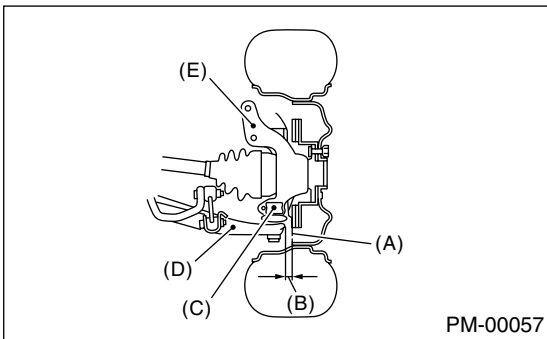

- (A) Disc cover
- (B) Relative movement
- (C) Ball joint
- (D) Transverse link
- (E) Housing

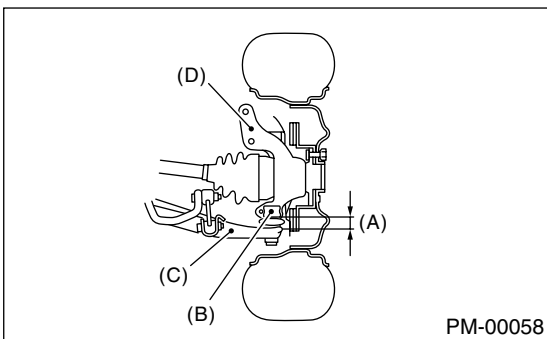

- (A) Relative movement
- (B) Ball joint
- (C) Transverse link
- (D) Housing

5) Damage of dust seal

Visually inspect ball joint dust seal. If it is damaged, remove transverse link. <Ref. to FS-14, Front Transverse Link.> And measure free play of ball joint. <Ref. to FS-17, Front Ball Joint.>

- (1) When looseness exceeds standard value, replace ball joint.
- (2) If the dust seal is damaged, replace with the new ball joint.

NOTE:

When transverse link ball joint has been removed or replaced, check toe-in of front wheel. If front wheel toe-in is not at tolerance value, adjust toe-in. <Ref. to FS-6, Wheel Alignment.>

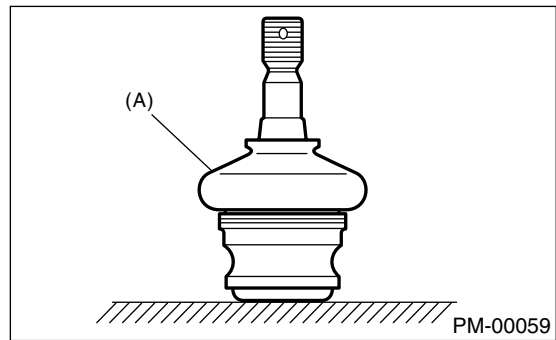

- (A) Dust seal

2. TRANSVERSE LINK'S REAR BUSHING

Check oil leaks at around liquid-filled bushing. If oil leaks, replace bushing.

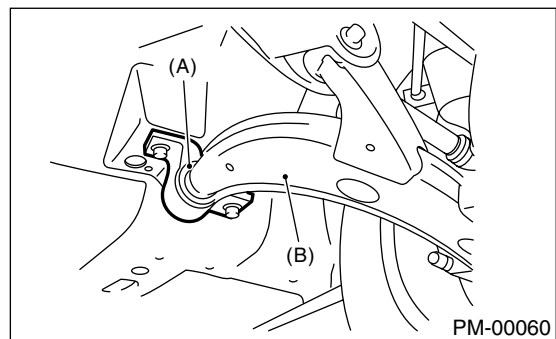

- (A) Rear bushing
- (B) Transverse link

3. WHEEL ARCH HEIGHT

- 1) Unload cargoes and set vehicle in curb weight (empty) condition.
- 2) Then, check wheel arch height of front and rear suspensions to ensure that they are within specified values.
- 3) When wheel arch height is out of tolerance value, visually inspect following components and replace deformed parts.
 - Suspension components [Front strut assembly and rear shock absorber assembly]
 - Body parts to which suspensions are installed.
- 4) When no components are deformed, adjust wheel arch height by replacing coil spring in the suspension whose wheel arch height is out of standard. <Ref. to FS-6, Wheel Alignment.> <Ref. to RS-8, Wheel Alignment.>

4. WHEEL ALIGNMENT OF FRONT SUSPENSION

- 1) Check alignment of front suspension to ensure that following items are within tolerance value.
 - Toe-in
 - Camber angle
 - Steering angle<Ref. to FS-6, Wheel Alignment.>
- 2) When toe-in and camber are out of tolerance value, adjust them so that they conform to respective adjustment standard value.
- 3) When right-and-left turning angles of tire are out of standard, adjust to standard value.

5. WHEEL ALIGNMENT OF REAR SUSPENSION

- 1) Check alignment of rear suspension to ensure that following items are within tolerance values.
 - Toe-in
 - Camber angle
 - Thrust angle<Ref. to RS-8, Wheel Alignment.>
- 2) When camber angle does not conform to tolerance value, visually inspect parts listed below. If deformation is observed, replace damaged parts.
 - Suspension components [Shock absorber, link F, link R, link UPR, arm R, sub frame, etc.]
 - Body parts to which suspensions are installed.
- 3) When toe-in and thrust angle are out of tolerance value, adjust them so that they conform to respective adjustment standard value.

6. OIL LEAKAGE OF STRUT AND SHOCK ABSORBER

Visually inspect front strut and rear shock absorber for oil leakage as instructed. Replace front strut and rear shock absorber if oil leaks excessively.

7. TIGHTNESS OF BOLTS AND NUTS

- Check bolts and nuts shown in the figure for looseness. Retighten bolts and nuts to specified torque. If self-lock nuts and bolts are removed, replace them with new ones.
- Front suspension: <Ref. to FS-3, COMPONENT, General Description.>
Rear suspension: <Ref. to RS-3, COMPONENT, General Description.>

8. DAMAGE TO SUSPENSION PARTS

- 1) Check the following parts and the fastening portion of the vehicle body for deformation or excessive rusting which impairs the suspension. If necessary, replace damaged parts with new ones. If minor rust formation, pitting, etc. are noted, remove rust and apply remedial anti-corrosion measures.
 - Front suspension
 - Transverse link
 - Crossmember
 - Strut
 - Rear suspension
 - Sub frame
 - Link F
 - Link R
 - Link UPR
 - Arm R
 - Shock absorber
- In the district where salt is sprayed to melt snow on a road in winter, check suspension parts for damage caused by rust every 12 months after lapse of 60 months. Take rust prevention measure as required.

WHEEL BEARING

PERIODIC MAINTENANCE SERVICES

22. Wheel Bearing

A: INSPECTION

1. FRONT WHEEL BEARING

NOTE:

Inspect the condition of front wheel bearing grease.

- 1) Jack up the front of vehicle.
- 2) While holding front wheel by hand, swing it in and out to check bearing free play.
- 3) Loosen wheel nuts and remove front wheel.
- 4) If bearing free play exists in step 2) above, attach a dial gauge to hub and measure axial displacement in axial direction.

Service limit:

Straight-ahead position within 0.05 mm (0.0020 in)

- 5) Remove bolts and self-locking nuts, and extract transverse link from front crossmember.
- 6) While lightly hammering spring pin which secures SFJ to transmission spindle, remove it.
- 7) Extract SFJ from transmission spindle. <Ref. to DS-18, Front Axle.>
- 8) While supporting front drive shaft horizontally with one hand, turn hub with the other to check for noise or binding.
If hub is noisy or binds, disassemble front axle and check condition of oil seals, bearing, etc.

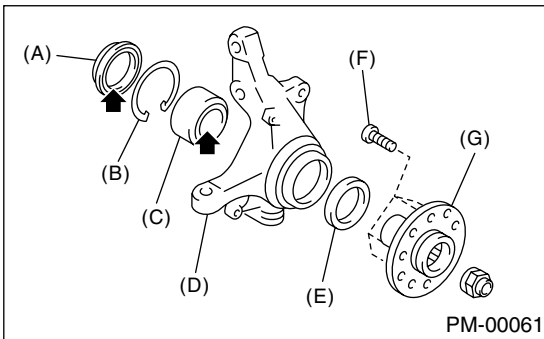

- (A) Inner oil seal
- (B) Snap ring
- (C) Bearing
- (D) Housing
- (E) Outer oil seal
- (F) Hub bolt
- (G) Hub

2. REAR WHEEL BEARING

- 1) Jack up the rear of vehicle.
- 2) While holding rear wheel by hand, swing it in and out to check bearing free play.
- 3) Loosen wheel nuts and remove rear wheel.
- 4) If bearing free play exists in step 2) above, attach a dial gauge to hub assembly and measure axial displacement in axial direction.

Service limit:

Straight-ahead position within 0.05 mm (0.0020 in)

- 5) Remove the DOJ of rear drive shaft from rear differential. <Ref. to DS-37, Rear Drive Shaft.>
- 6) While supporting rear drive shaft horizontally with one hand, turn hub assembly with the other to check for noise or binding.
If hub assembly is noisy or binds, disassemble rear axle and check condition of oil seals, bearings, etc.

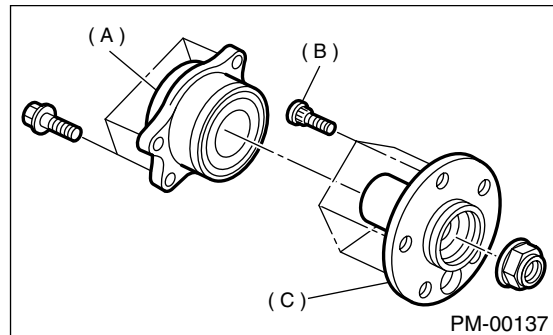

- (A) Hub unit
- (B) Hub bolt
- (C) Hub

23. Axle Boots & Joints

A: INSPECTION

1. FRONT AND REAR AXLE BOOTS

Inspect front axle boots (A) and rear axle boots (B) for deformation, damage or failure. If faulty, replace them with new ones. <Ref. to DS-29, Front Drive Shaft.> <Ref. to DS-37, Rear Drive Shaft.>

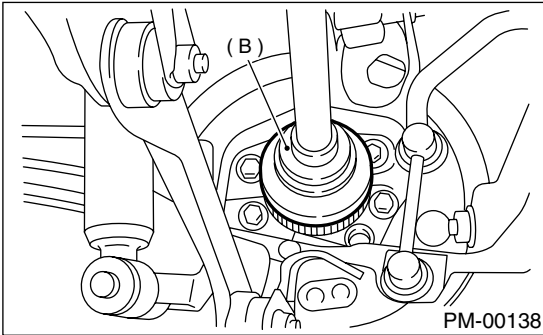
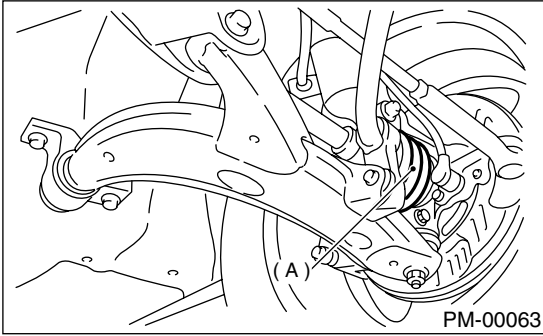

2. PROPELLER SHAFT

Inspect propeller shaft for damage or failure. If faulty, replace with a new one. <Ref. to DS-15, Propeller Shaft.>

24. Tire Rotation

A: INSPECTION

- 1) Replace the tire if the tread depth is less than 1.6 mm (0.063 in) or if wear indicators appear across the tire tread. (It is recommended that both right and left tires are replaced as a set.)
- 2) Adjust the wheel alignment if abnormally uneven tire wear is found.
- 3) Also, rotate the tires between the front and rear tires as illustrated, in order to ensure uniform tire wear.

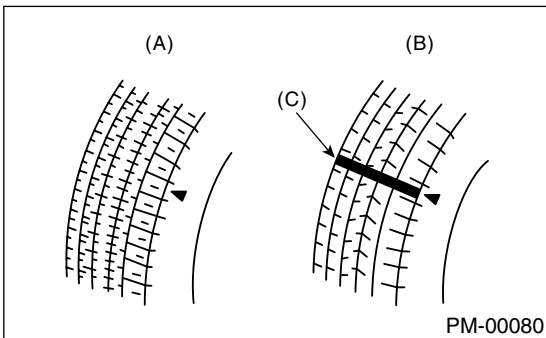
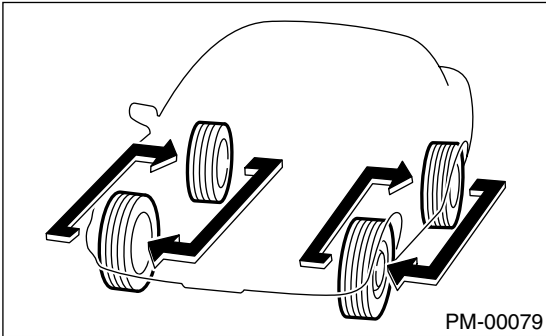

- (A) New tread
- (B) Worn tread
- (C) Tread wear indicator

25. Steering System (Power Steering)

A: INSPECTION

1. STEERING WHEEL

1) Set steering wheel in a straight-ahead position, and check wheel spokes to make sure they are correctly set in their specified positions.

2) Lightly turn steering wheel to the left and right to determine the point where front wheels start to move.

Measure the distance of the movement of steering wheel at the outer periphery of wheel.

Steering wheel free play:

0 — 17 mm (0 — 0.67 in)

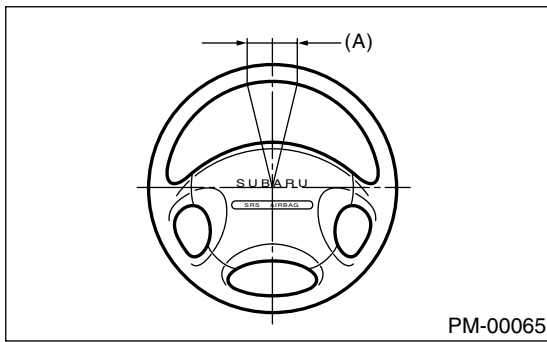

(A) Free play

Move steering wheel vertically toward the shaft to ascertain if there is play in the direction.

Maximum permissible play:

0.5 mm (0.020 in)

3) Drive vehicle and check the following items during operation.

(1) Steering force

The effort required for steering should be smooth and even at all points, and should not vary.

(2) Pull to one side

Steering wheel should not be pulled to either side while driving on a level surface.

(3) Wheel runout

Steering wheel should not show any sign of runout.

(4) Return factor

Steering wheel should return to its original position after it has been turned and then released.

2. STEERING SHAFT JOINT

1) When steering wheel free play is excessive, disconnect universal joint of steering shaft and check it for any play and yawing torque (at the point of the crossing direction). Also inspect for any damage to sealing or worn serrations. If the joint is loose, retighten the mounting bolts to the specified torque.

Tightening torque:

24 N·m (2.4 kgf·m, 17.4 ft·lb)

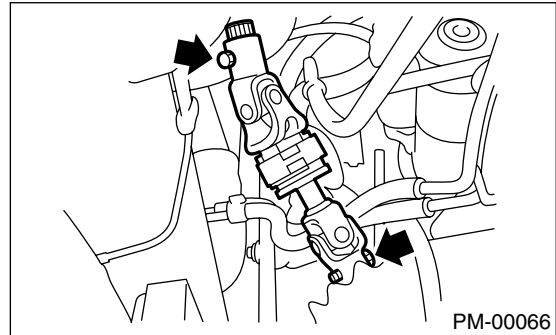

3. GEARBOX

1) With wheels placed on a level surface, turn steering wheel 90° in both the left and right directions.

While wheel is being rotated, reach under vehicle and check for looseness in gearbox.

Tightening torque:

59 N·m (6.0 kgf·m, 43.4 ft·lb)

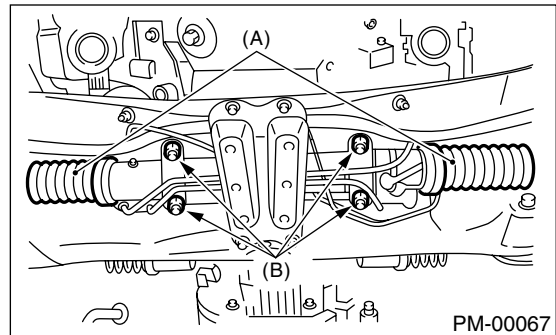

(A) Boot

(B) Gearbox mounting bolts

2) Check boot for damage, cracks or deterioration.
3) With vehicle on a level surface, quickly turn steering wheel to the left and right.

While steering wheel is being rotated, check the gear backlash. If any unusual noise is noticed, adjust the gear backlash in the following manner.

(1) Tighten adjusting screw to 7.4 N·m (0.75 kgf·m, 5.4 ft·lb) and then loosen. Repeat this operation twice.

(2) Retighten adjusting screw to 7.4 N·m (0.75 kgf·m, 5.4 ft·lb) and back off 25°.

STEERING SYSTEM (POWER STEERING)

PERIODIC MAINTENANCE SERVICES

- (3) Apply liquid packing to at least 1/3 of entire perimeter of adjusting screw thread.

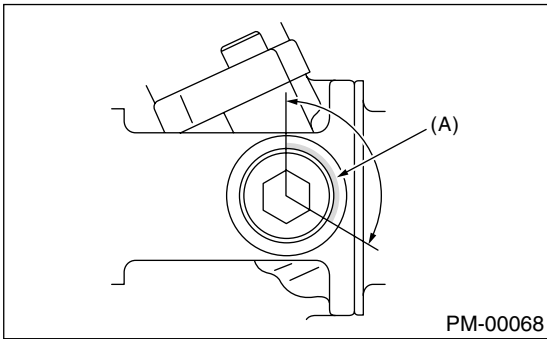

(A) Apply liquid packing to at least 1/3 of entire perimeter.

- (4) Install lock nut. While holding adjusting screw with a wrench, tighten lock nut using ST 926230000 SPANNER

Tightening torque (Lock nut):
39 N·m (4.0 kgf·m, 29 ft·lb)

Hold the adjusting screw with a wrench to prevent it from turning while tightening the lock nut.

4. TIE-ROD

- 1) Check tie-rod and tie-rod ends for bends, scratches or other damage.

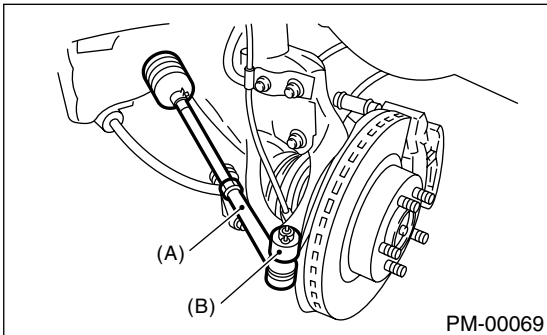

(A) Tie-rod end
(B) Knuckle arm

- 2) Check connections of knuckle ball joints for play, inspect for damage on dust seals, and check free play of ball studs. If castle nut is loose, retighten it to the specified torque, then tighten further up to 60° until cotter pin hole is aligned.

Tightening torque:
27 N·m (2.75 kgf·m, 19.9 ft·lb)

- 3) Check lock nut on the tie-rod end for tightness. If it is loose, retighten it to the specified torque.

Tightening torque:
83 N·m (8.5 kgf·m, 61.5 ft·lb)

5. POWER STEERING FLUID LEVEL

NOTE:

The fluid level must be checked when the temperature of the reservoir tank surface is approximately 20°C (68°F).

- 1) Place vehicle with engine "off" on the flat and level surface.
- 2) Check the fluid level using the scale on the outside of the reservoir tank (A). If the level is below "MIN" (B), add fluid to bring it up to "MAX" (C).

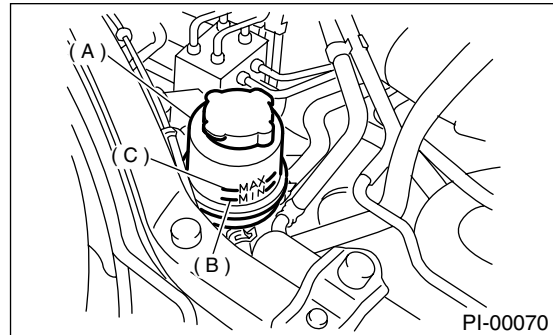

NOTE:

If fluid level is at MAX level or above, drain fluid to keep the level in the specified range of indicator by using a syringe or the like.

Recommended fluid:
Dexron III

Fluid capacity:
0.7 ℓ (0.7 US qt, 0.6 Imp qt)

6. POWER STEERING FLUID FOR LEAKS

Inspect the underside of oil pump and gearbox for power steering system, hoses, piping and their couplings for fluid leaks.

If fluid leaks are found, correct them by retightening their fitting bolts (or nuts) and/or replacing their parts.

NOTE:

- Wipe the leakage fluid off after correcting fluid leaks, or a wrong diagnosis is taken later.
- Also pay attention to clearances between hoses (or pipings) and other parts when inspecting fluid leaks.

7. HOSES OF OIL PUMP FOR DAMAGES

Check pressure hose and return hose of oil pump for crack, swell or damage. Replace hose with a new one if necessary.

NOTE:

Prevent hoses from revolving and/or turning when installing hoses.

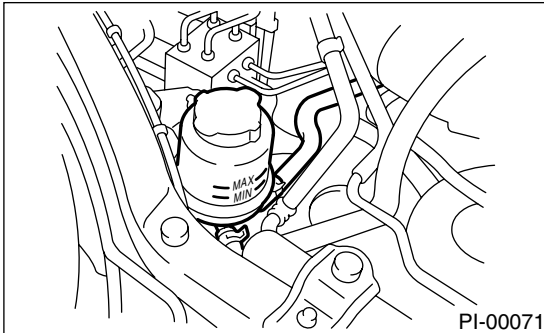

8. POWER STEERING PIPES FOR DAMAGE

Check power steering pipes for corrosion and damage.

Replace pipes with new ones if necessary.

9. GEARBOX BOOTS

Inspect both sides of gearbox boots as follows, and correct the defects if necessary.

1) (A) and (B) positions of gearbox boot are fitted correspondingly in (A) and (B) grooves of gearbox and the rod.

2) Clips are fitted outside of (A) and (B) positions of boot.

3) Boot does not have crack and hole.

NOTE:

Rotate (B) position of gearbox boot against twist of it produced by adjustment of toe-in, etc. Apply grease to the groove (C).

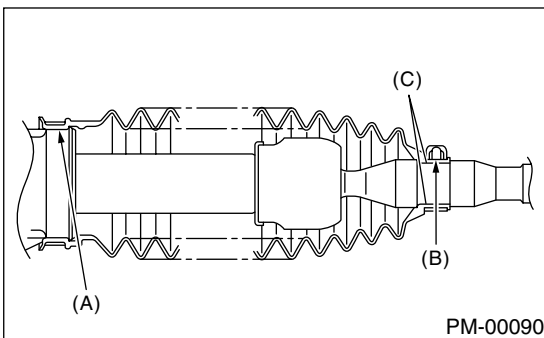

10. FITTING BOLTS AND NUTS

Inspect fitting bolts and nuts of oil pump and bracket for looseness, and retighten them if necessary.

Inspect and/or retighten them when engine is cold.

SUPPLEMENTAL RESTRAINT SYSTEM

PERIODIC MAINTENANCE SERVICES

26. Supplemental Restraint System

A: INSPECTION

Check the airbag system in accordance with the result of the self-diagnosis. <Ref. to AB-2, Basic Diagnostic Procedure.>

1) Ensure that airbag connectors are connected. If not, properly connect. When the ignition switch is turned ON with the connector(s) disconnected, the airbag warning light blinks to identify the fault.

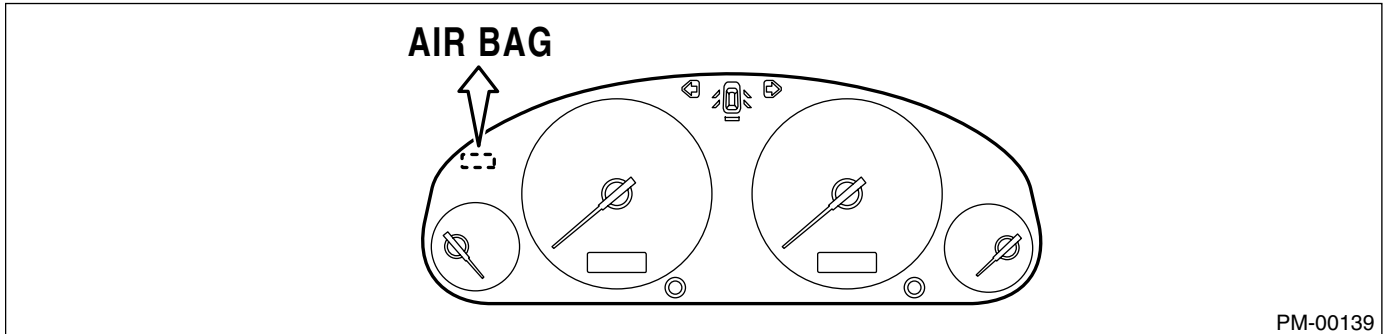

2) Turn the ignition switch ON, and connect the airbag diagnosis terminal of the service connector (located below lower cover) to the ground terminal.

3) The warning light blinks to indicate a trouble code (a fault is identified). When the airbag system is in good order (no trouble codes are stored in the memory), the warning light blinks on and off at 0.6 second intervals (as long as the diagnosis terminal is connected to the ground terminal).

4) When the warning light indicates a trouble code, check the airbag system in accordance with the troubleshooting procedure. <Ref. to AB-2, Basic Diagnostic Procedure.>