

STARTING/CHARGING SYSTEMS

SC(H4SO)

	Page
1. General Description	2
2. Starter	7
3. Generator	15
4. Battery	21



GENERAL DESCRIPTION

STARTING/CHARGING SYSTEMS

1. General Description

A: SPECIFICATIONS

Item		Designation		
		MT	AT	
Starter	Type	Reduction type		
	Model	228000-7131	228000-7141	
	Manufacturer	DENSO CORPORATION		
	Voltage and output	12 V — 1.0 kW	12 V — 1.4 kW	
	Direction of rotation	Counterclockwise (when observed from pinion)		
	Number of pinion teeth	9		
	No-load characteristics	Voltage	11 V	
		Current	90 A or less	
		Rotating speed	3,000 rpm or more	2,900 rpm or more
	Load characteristics	Voltage	8 V	
		Current	280 A or less	370 A or less
		Torque	9.8 N·m (1.0 kgf-m, 7.2 ft-lb)	13.7 N·m (1.4 kgf-m, 10.1 ft-lb)
		Rotating speed	900 rpm or more	880 rpm or more
	Lock characteristics	Voltage	5 V	
		Current	800 A or less	1,050 A or less
Torque		27.5 N·m (2.8 kgf-m, 20.3 ft-lb) or more		
Generator	Type	Rotating-field three-phase type, Voltage regulator built-in type		
	Model	A002TB2891ZC		
	Manufacturer	MITSUBISHI ELECTRIC		
	Voltage and output	12 V — 90 A		
	Polarity on ground side	Negative		
	Rotating direction	Clockwise (when observed from pulley side.)		
	Armature connection	3-phase Y-type		
	Output current	1,500 rpm — 36 A or more		
		2,500 rpm — 65A or more		
5,000 rpm — 86 A or more				
Regulated voltage	14.1 - 14.8 V [20°C (68°F)]			
Battery	Reserve capacity	amps min.	90	110
	Cold cranking	amp.	430	490

B: COMPONENT

1. STARTER

- MT VEHICLES

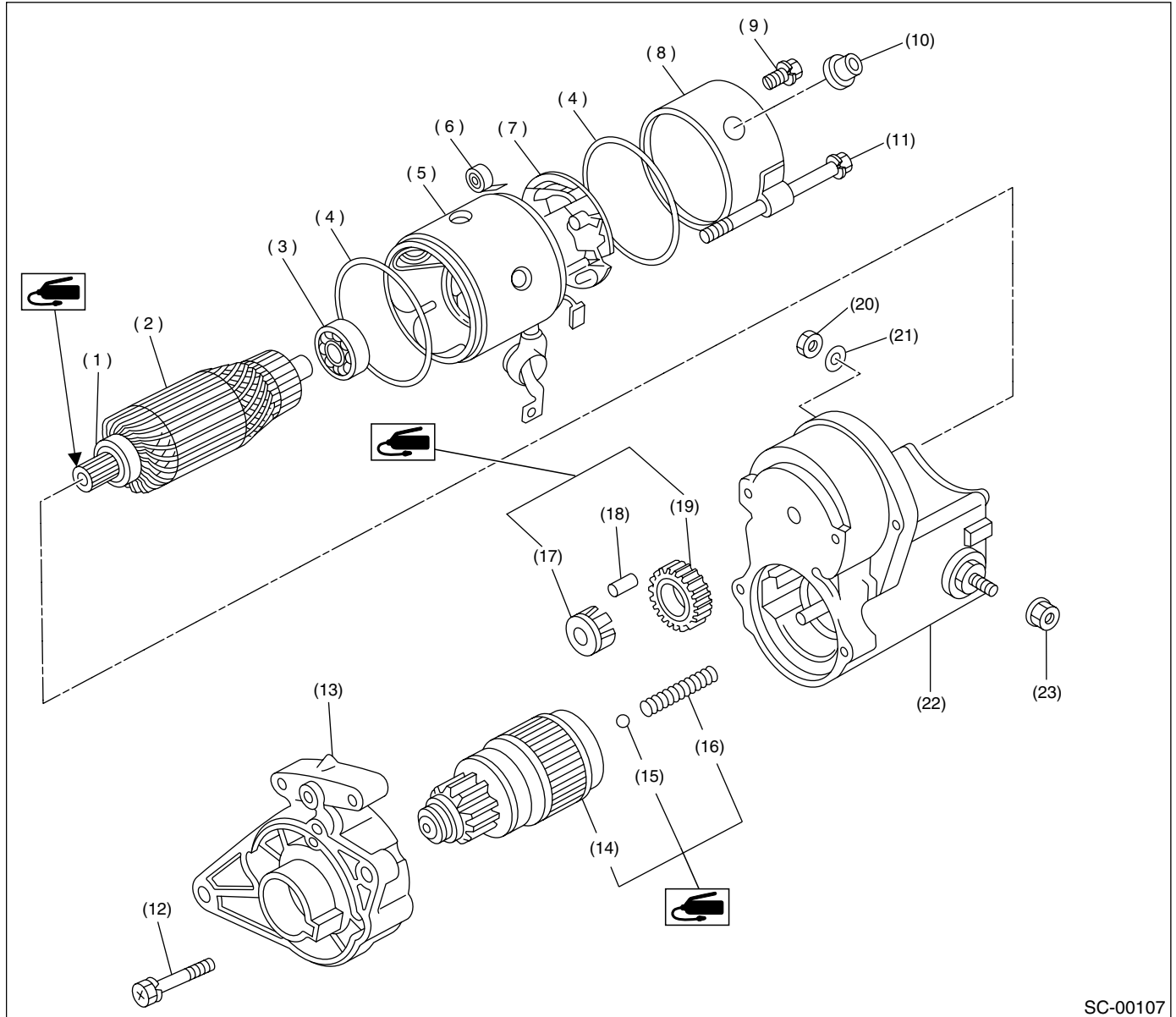

SC-00107

- | | | |
|------------------------|-------------------------|----------------------|
| (1) Front ball bearing | (9) Screw | (17) Retainer |
| (2) Armature | (10) Cover | (18) Roller |
| (3) Rear ball bearing | (11) Through bolt | (19) Idle gear |
| (4) O-ring | (12) Screw & washer | (20) Nut |
| (5) Yoke | (13) Starter housing | (21) Spring washer |
| (6) Brush spring | (14) Overrunning clutch | (22) Magnetic switch |
| (7) Brush holder | (15) Steel ball | (23) Nut |
| (8) End frame | (16) Spring | |

GENERAL DESCRIPTION

STARTING/CHARGING SYSTEMS

• AT VEHICLES

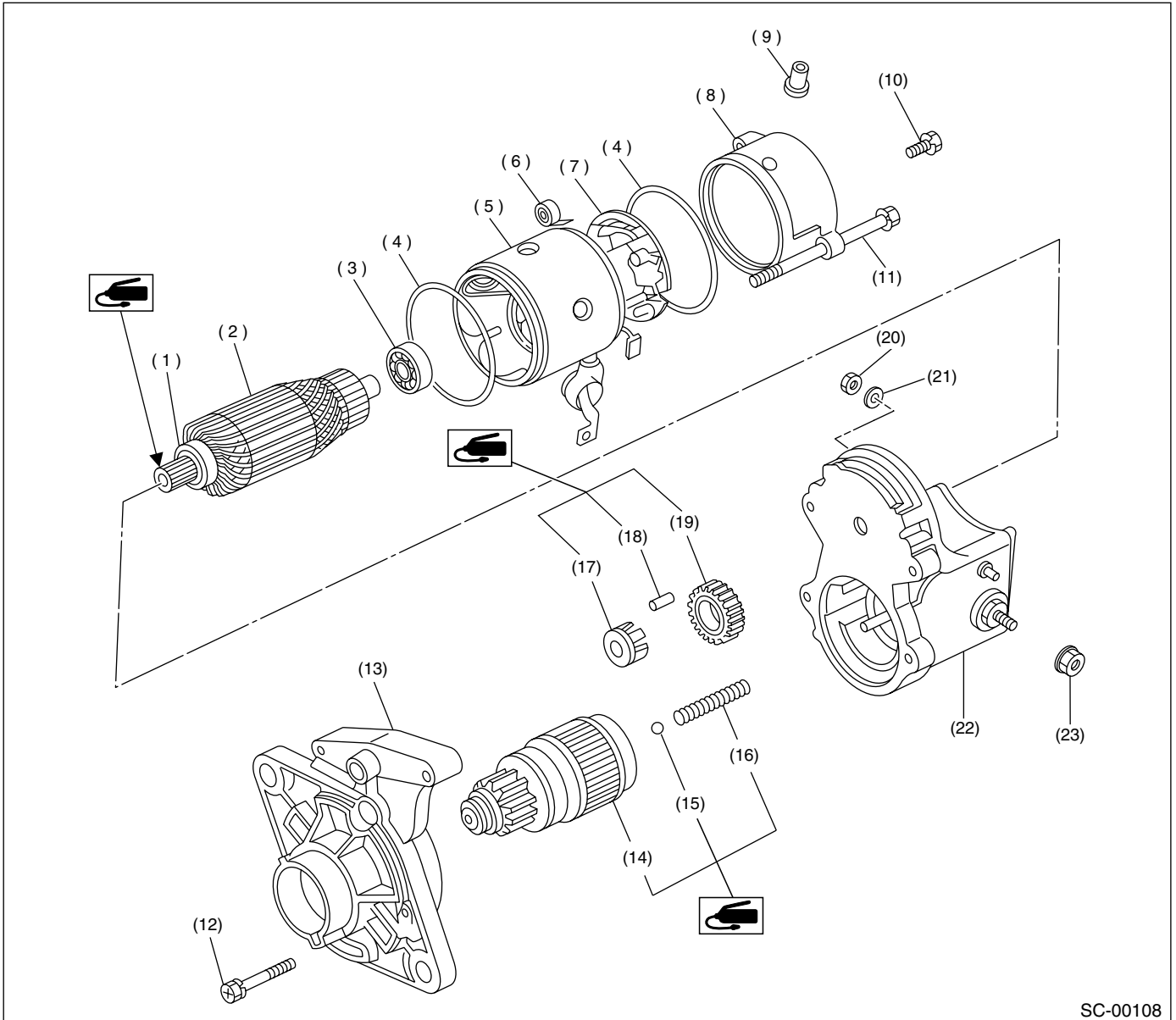

SC-00108

- | | | |
|------------------------|-------------------------|----------------------|
| (1) Front ball bearing | (9) Cover | (17) Retainer |
| (2) Armature | (10) Screw | (18) Roller |
| (3) Rear ball bearing | (11) Through-bolt | (19) Idle gear |
| (4) O-ring | (12) Screw & washer | (20) Nut |
| (5) Yoke | (13) Starter housing | (21) Spring washer |
| (6) Brush spring | (14) Overrunning clutch | (22) Magnetic switch |
| (7) Brush holder | (15) Steel ball | (23) Nut |
| (8) End frame | (16) Spring | |

2. GENERATOR

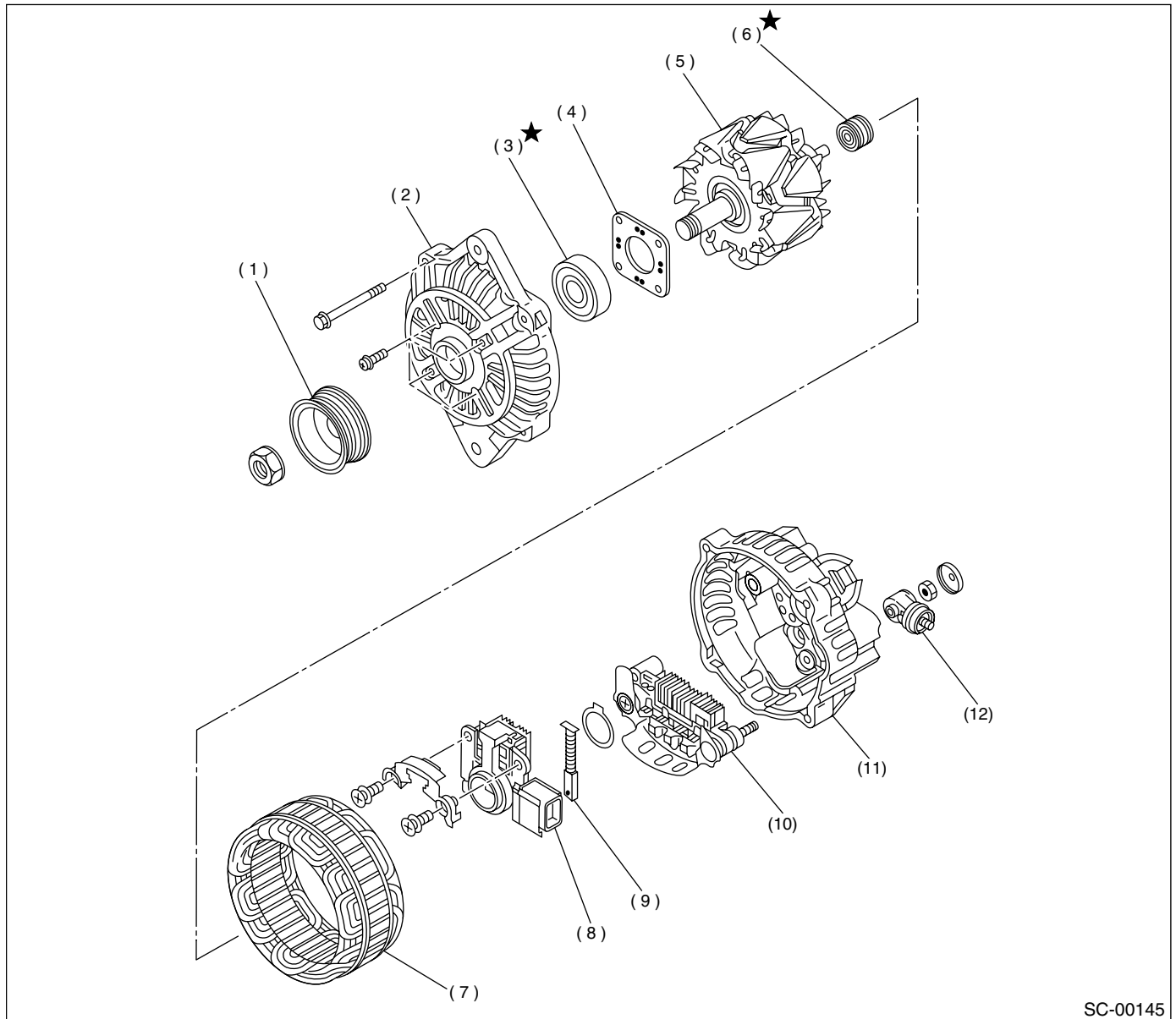

SC-00145

- (1) Pulley
- (2) Front cover
- (3) Ball bearing
- (4) Bearing retainer

- (5) Rotor
- (6) Bearing
- (7) Stator coil
- (8) IC regulator with brush

- (9) Brush
- (10) Rectifier
- (11) Rear cover
- (12) Terminal

GENERAL DESCRIPTION

STARTING/CHARGING SYSTEMS

C: CAUTION

- Wear working clothing, including a cap, protective goggles, and protective shoes during operation.
- Remove contamination including dirt and corrosion before removal, installation or disassembly.
- Keep the disassembled parts in order and protect them from dust or dirt.
- Before removal, installation or disassembly, be sure to clarify the failure. Avoid unnecessary removal, installation, disassembly, and replacement.
- Be careful not to burn your hands, because each part in the vehicle is hot after running.
- Be sure to tighten fasteners including bolts and nuts to the specified torque.
- Place shop jacks or safety stands at the specified points.
- Before disconnecting electrical connectors of sensors or units, be sure to disconnect ground cable from battery.

2. Starter

A: REMOVAL

1) Disconnect ground cable from battery.

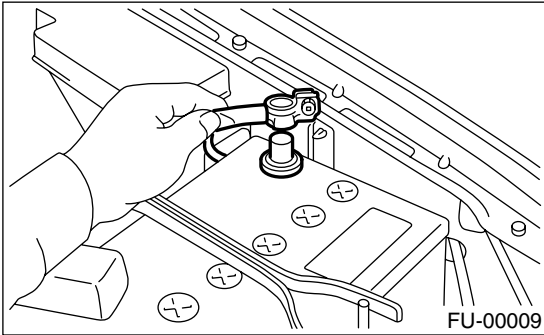

2) Remove air cleaner case. (Non-Turbo model)
<Ref. to IN(H4SO)-5, REMOVAL, Air Cleaner Case.>

3) Remove intercooler. (Turbo model)
<Ref. to IN(H4DOTC)-10, REMOVAL, Intercooler.>

4) Remove air cleaner case stay.

- MT vehicles

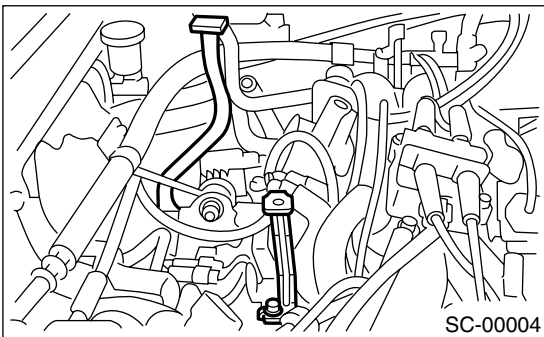

- AT vehicles

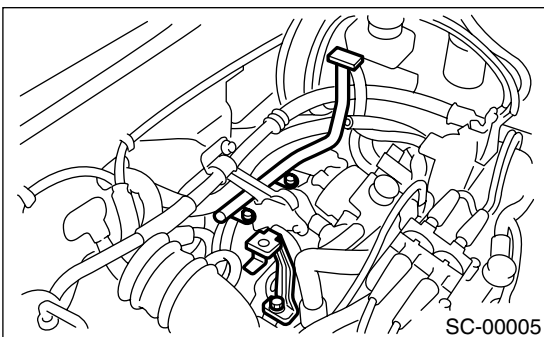

5) Disconnect connector and terminal from starter.

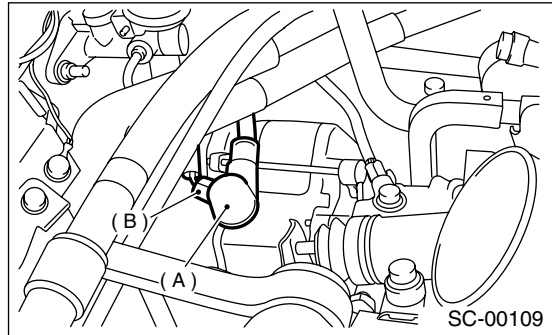

- (A) Terminal
- (B) Connector

6) Remove starter from transmission.

B: INSTALLATION

Install in the reverse order of removal.

Tightening torque:

50 N·m (5.1 kgf-m, 37 ft-lb)

C: DISASSEMBLY

1) Disconnect lead wire (A) from magnetic switch (B).

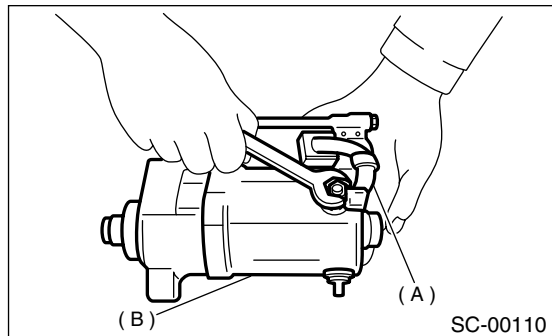

2) Remove through-bolts (A) from end frame (B).

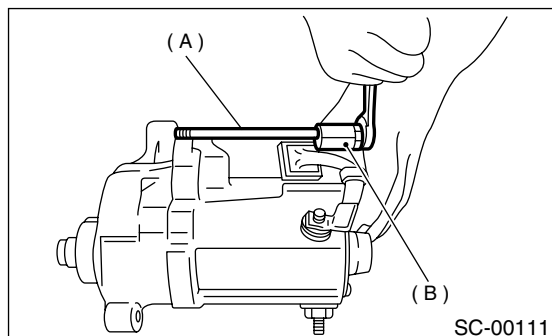

STARTER

STARTING/CHARGING SYSTEMS

3) Remove yoke (A) from magnetic switch (B).

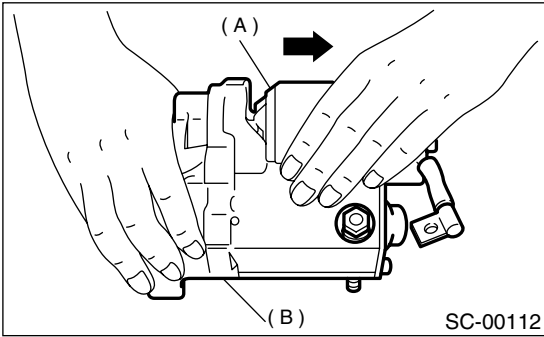

4) Remove screws (A) securing brush holder to end frame (B).

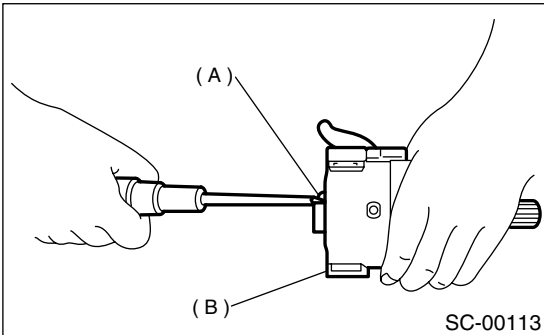

5) Separate yoke (A) from end frame (B).

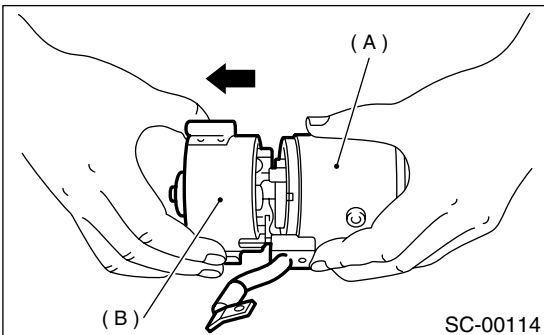

6) Remove brush (A) by lifting up positive (+) side brush spring (B) using long-nose pliers.

CAUTION:
Be careful not to damage brush and commutator.

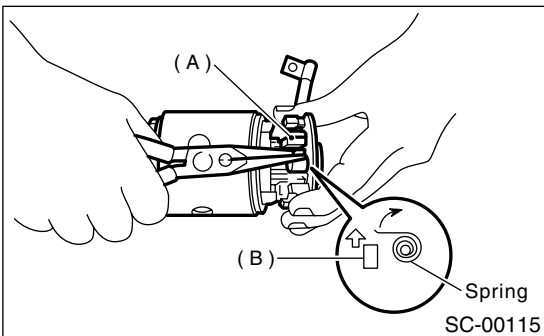

7) Remove armature (A) from yoke (B).

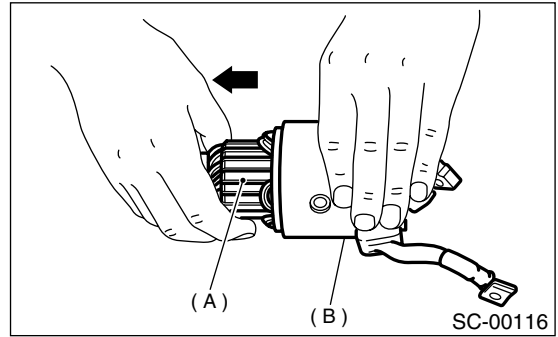

8) Remove screws securing magnetic switch (A) to housing (B).

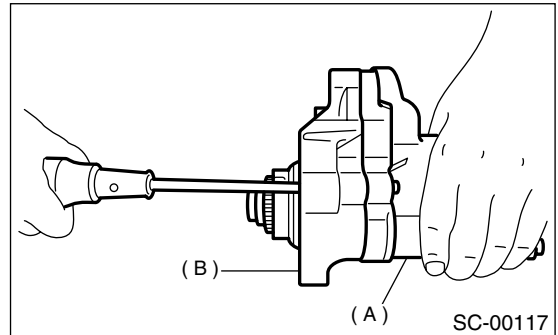

9) Remove housing (A) from magnetic switch (B).

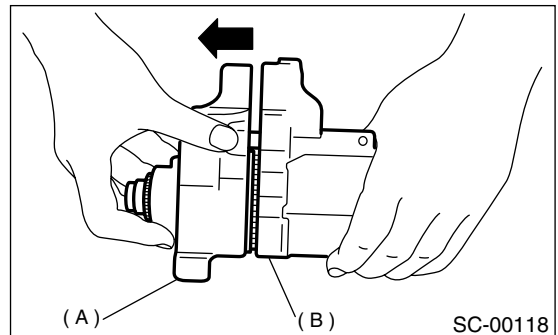

10) Remove clutch (A) from housing (B).

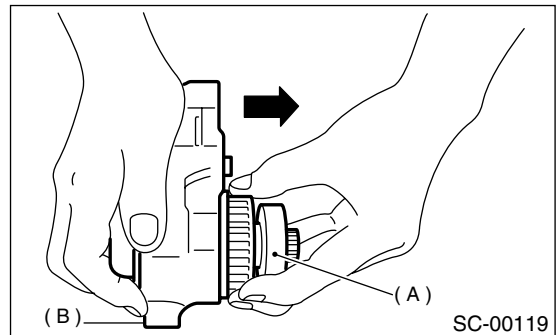

11) Take out steel ball (A) from clutch (B).

CAUTION:

Be careful not to lose steel ball.

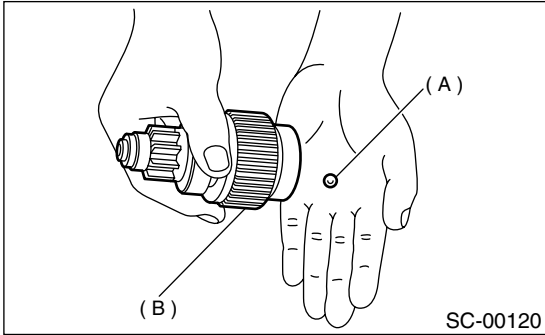

12) Remove idle gear (A) from housing.

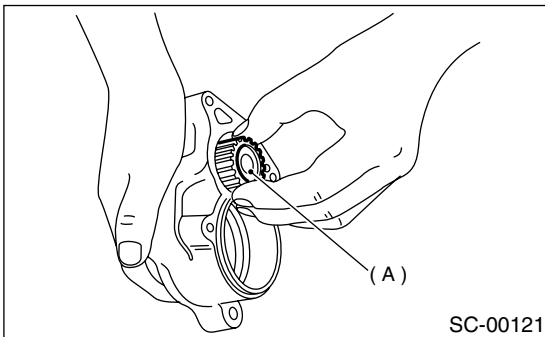

13) Remove retainer and roller (A) from housing.

CAUTION:

Be careful not to drop retainer and roller.

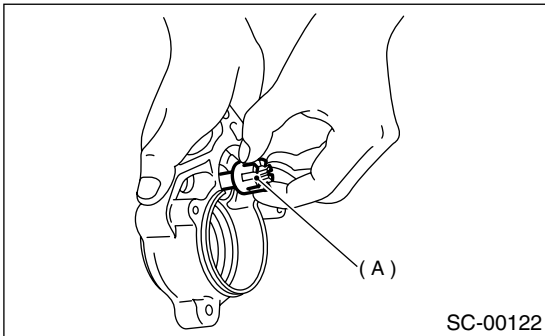

14) Remove coil spring (A) from magnetic switch (B).

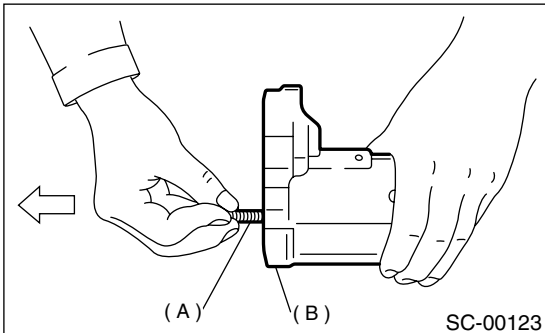

D: ASSEMBLY

Assemble in the reverse order of disassembly. Observe the following:

1) Before assembling, apply grease to the points shown in "COMPONENT PARTS". <Ref. to SC(H4SO)-3, COMPONENT, General Description.>

2) Assembling magnetic switch, clutch, and housing

To assemble, first install clutch to magnetic switch, then install idle gear, and finally install clutch.

CAUTION:

- Do not forget to install steel ball and coil spring to clutch.
- Attach bearing to idle gear beforehand.

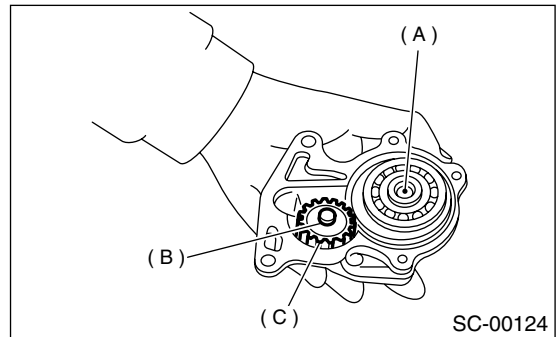

- (A) Steel ball
- (B) Retainer
- (C) Idle gear

3) Installing armature (A) to yoke (B)

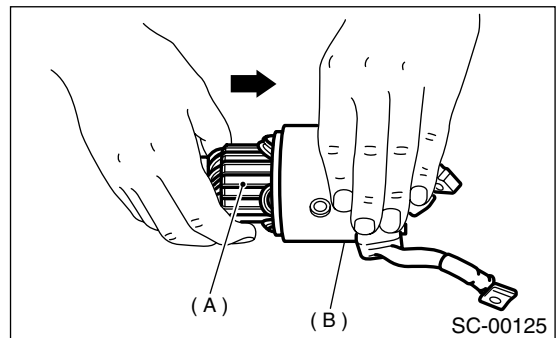

STARTER

STARTING/CHARGING SYSTEMS

4) Installing brushes

Assemble brush holder to yoke as shown, then assemble two yoke-side brushes to brush holder.

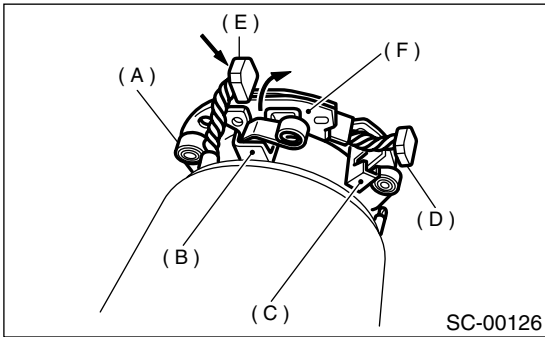

- (A) Brush spring
- (B) Brush holder hole (+)
- (C) Brush holder hole (-)
- (D) Brush (-)
- (E) Brush (+)
- (F) Insulator

5) Installing end frame

When assembling end frame to yoke, align notched portion (A) of end frame with lead wire grommet (B).

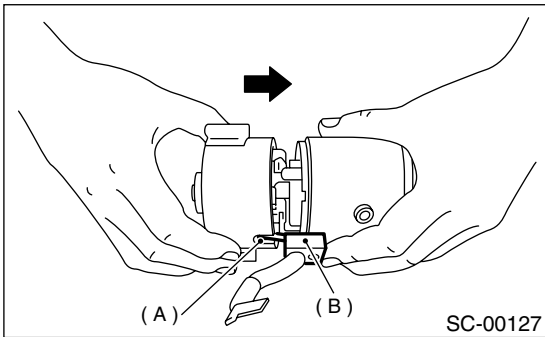

6) Installing yoke

When installing yoke to magnetic switch, align notch (A) of yoke with groove of magnetic switch.

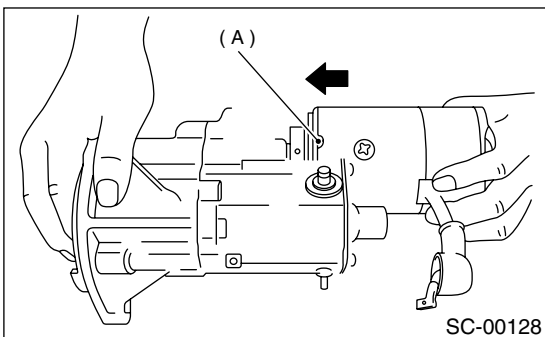

E: INSPECTION

1. ARMATURE

1) Check commutator for any sign of burns or rough surfaces or stepped wear. If wear is of a minor nature, correct it by using sand paper.

2) Run-out test

Check the commutator run-out and replace if it exceeds the limit.

Commutator run-out:

Standard

0.02 mm (0.0008 in), or less

Service limit

Less than 0.05 mm (0.0020 in)

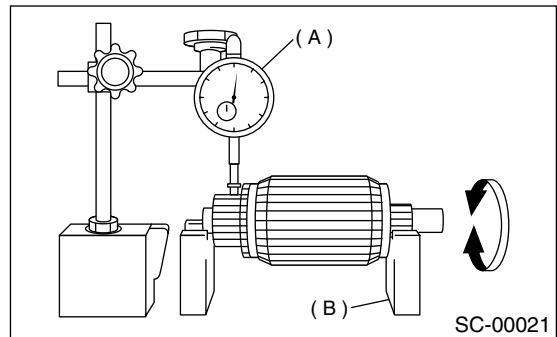

- (A) Dial gauge
- (B) V-block

3) Depth of segment mold

Check the depth of segment mold.

Depth of segment mold:

0.6 mm (0.024 in)

Limit

0.2 mm (0.008 in)

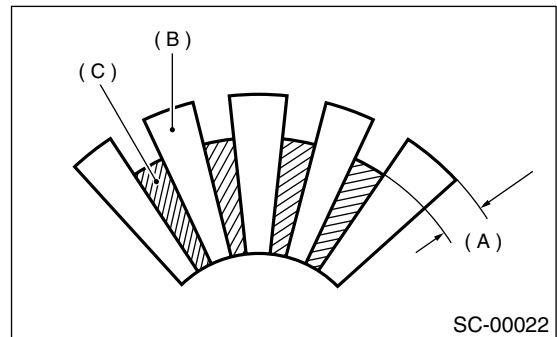

- (A) Depth of mold
- (B) Segment
- (C) Mold

4) Armature short-circuit test

Check armature for short-circuit by placing it on growler tester. Hold a iron sheet against armature core while slowly rotating armature. A short-circuited armature will cause the iron sheet to vibrate and to be attracted to core. If the iron sheet is attracted or vibrates, the armature, which is short-circuited, must be replaced or repaired.

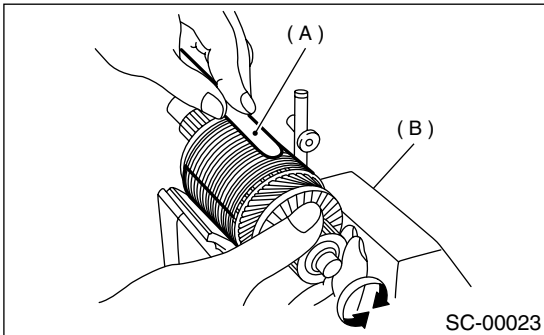

- (A) Iron sheet
- (B) Growler tester

5) Armature ground test

Using circuit tester, touch one probe to the commutator segment and the other to shaft. If there is no continuity, it is normal. If there is a continuity armature is grounded. Replace armature if it is grounded.

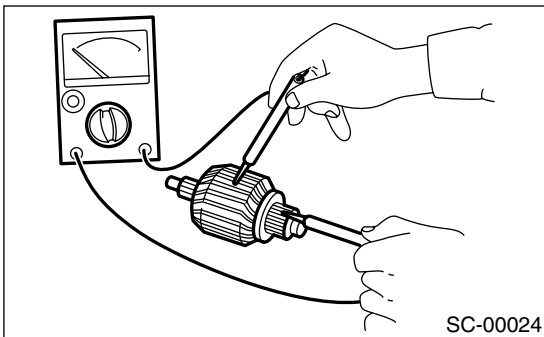

2. YOKE

Make sure pole is set in position.

3. OVERRUNNING CLUTCH

Inspect teeth of pinion for wear and damage. Replace if it is damaged. Rotate pinion in correct direction of rotation (counter clockwise). It should rotate smoothly. But in opposite direction, it should be locked.

CAUTION:

Do not clean overrunning clutch with oil to prevent grease from flowing out.

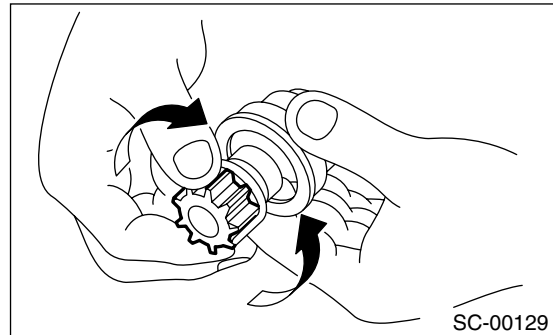

4. BRUSH AND BRUSH HOLDER

1) Brush length

Measure the brush length and replace if it exceeds the service limit.

Replace if abnormal wear or cracks are noticed.

Brush length:

Standard

15 mm (0.59 in)

Service limit

10 mm (0.39 in)

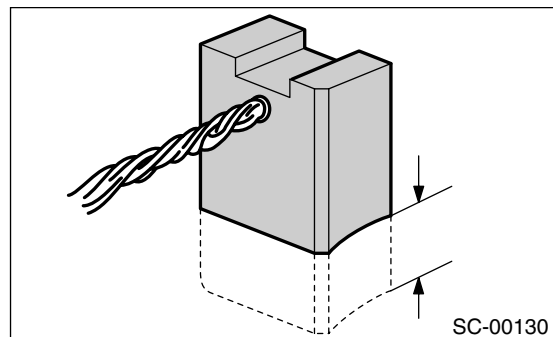

2) Brush movement

Be sure brush moves smoothly inside brush holder.

3) Insulation resistance of brush holder

Be sure there is no continuity between brush holder and its plate.

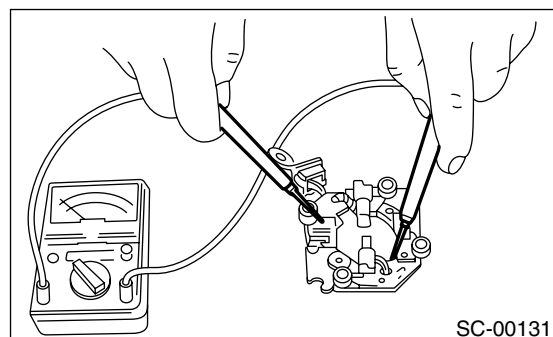

STARTER

STARTING/CHARGING SYSTEMS

- 4) Brush spring force
Measure brush spring force with a spring scale. If it is less than the service limit, replace brush spring.

Brush spring force:

Standard

18.6 N (1.9 kgf, 4.2 lb) (when new)

Service limit

6.9 N (0.7 kgf, 1.5 lb)

5. BEARING

- 1) Rotate bearing by hand; no binding should exist.
- 2) Rotate bearing rapidly; no abnormal noise should be heard.

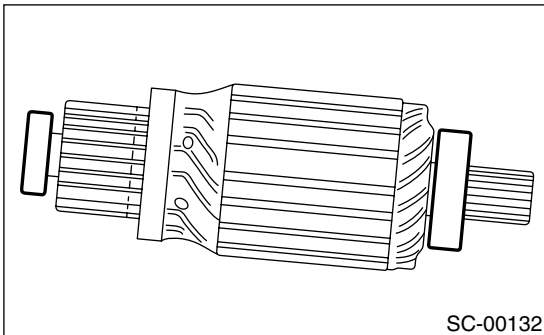

6. MAGNETIC SWITCH

CAUTION:

- The following magnetic switch tests should be performed with specified voltage applied.
- Each test should be conducted within 3 to 5 seconds. Power to be furnished should be one-half the rated voltage.

1) Pull-in test

Connect two battery negative leads onto magnetic switch body and terminal C respectively. Then connect battery positive lead onto terminal 50. Pinion should extend when lead connections are made.

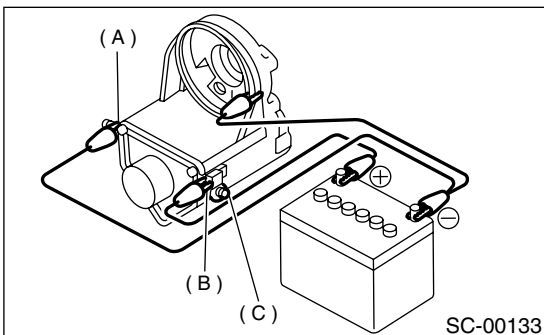

- (A) Terminal C
(B) Terminal 50
(C) Terminal M

2) Holding-in test

Disconnect lead from terminal C with pinion extended. Pinion should be held in the extended position.

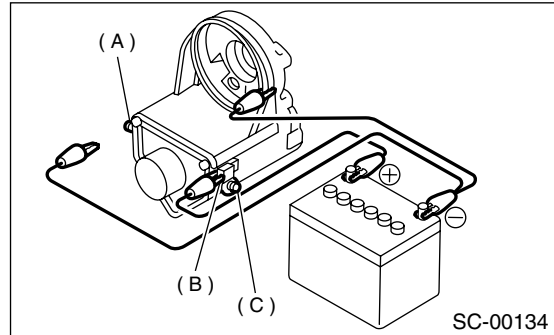

- (A) Terminal C
(B) Terminal 50
(C) Terminal M

3) Return test

Connect two battery negative leads onto terminal 50 and onto switch body respectively. Then connect battery positive lead onto terminal C. Next, disconnect lead from terminal 50. Pinion should return immediately.

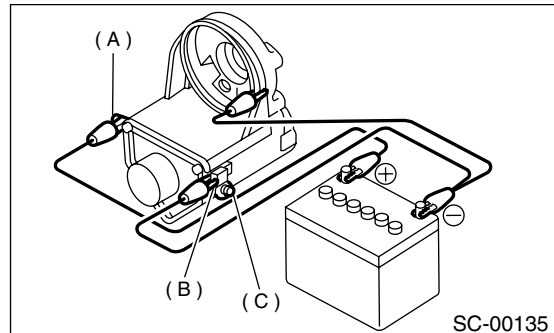

- (A) Terminal C
(B) Terminal 50
(C) Terminal M

7. PERFORMANCE TEST

The starter is required to produce a large torque and high rotating speed, but these starter characteristics vary with the capacity of the battery. It is therefore important to use a battery with the specified capacity whenever testing the starter.

The starter should be checked for the following three items:

• No-load test

Measure the maximum rotating speed and current under a no-load state.

• Load test

Measure the magnitude of current needed to generate the specified torque and rotating speed.

STARTER

- Stall test

Measure the torque and current when the armature is locked.

1) No-load test

Under no-load state, measure its rotating speed and current, using the specified battery. Measured values must meet the following standards:

No-load test (Standard):

Voltage/Current

11 V/90 A, or more

Rotating speed

228000-7131: 3,000 rpm, or more

228000-7141: 2,900 rpm, or more

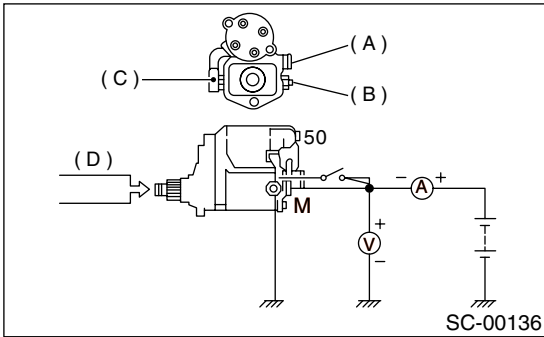

- (A) Terminal 50
- (B) Terminal M
- (C) Terminal C
- (D) Tachometer

2) Load test (For reference)

Perform this test to check maximum output of starter. Use test bench which is able to apply load (brake) to starter. Measure torque value and rotating speed under the specified voltage and current conditions while controlling braking force applied to starter.

CAUTION:

Change engagement position of overrunning clutch and make sure it is not slipping.

Load test (Standard):

228000-7131

Voltage/Load

8 V/9.8 N-m (1.0 kgf-m, 7.2 ft-lb)

Current/Speed

280 A, or less/900 rpm, or more

228000-7141

Voltage/Load

8 V/13.7 N-m (1.4 kgf-m, 10.1 ft-lb)

Current/Speed

370 A, or less/880 rpm, or more

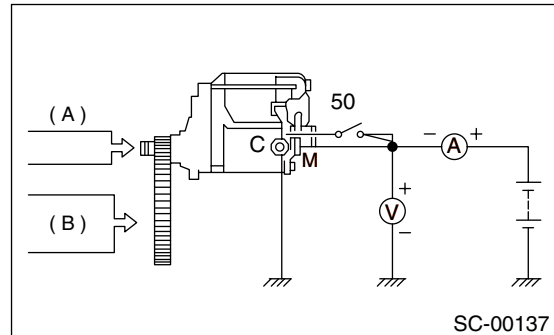

- (A) Tachometer
- (B) Torque gauge

3) Stall test

Using the same test equipment used for load test, apply brake to lock starter armature. Then measure voltage, current, and torque values.

Measured values must meet the following standard.

Stall test (Standard):

228000-7131

Voltage/Current

5 V/800 A, or less

Torque

27.5 N-m (2.8 kgf-m, 20.3 ft-lb), or more

228000-7141

Voltage/Current

5 V/1,050 A, or less

Torque

27.5 N-m (2.8 kgf-m, 20.3 ft-lb), or more

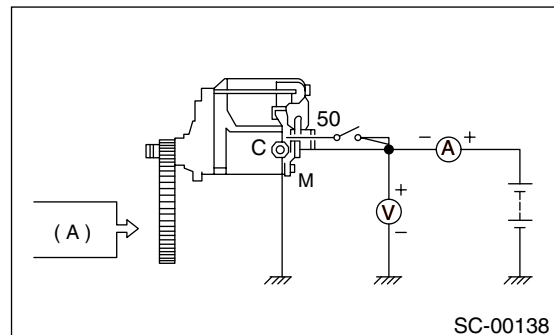

- (A) Torque gauge

STARTER

STARTING/CHARGING SYSTEMS

NOTE:

Low rotating speed or excessive current during no-load test may be attributable to high rotating resistance of starter due to improper assembling.

Small current and no torque during stall test may be attributable to excessive contact resistance between brush and commutator; whereas, normal current and insufficient torque may be attributable to shorted commutator or poor insulation.

Starter can be considered normal if it passes no-load and stall tests; therefore, load test may be omitted.

3. Generator

A: REMOVAL

1) Disconnect ground cable from battery.

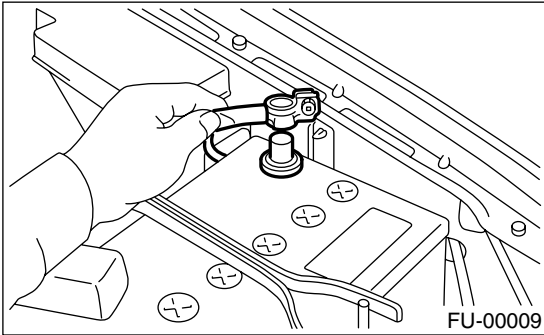

2) Disconnect the connector and terminal from generator.

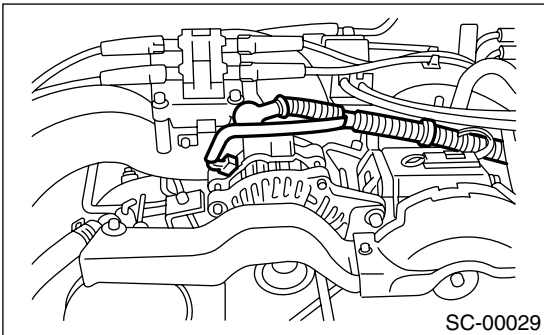

3) Remove the V-belt cover.

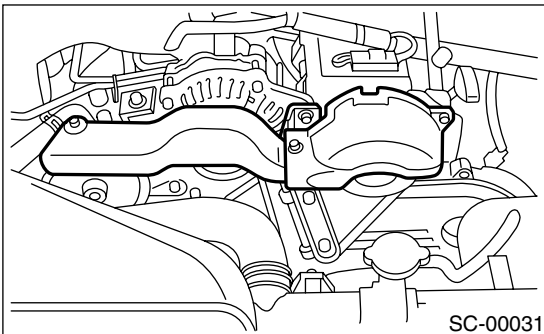

4) Remove the front side V-belt.
 <Ref. to ME(H4SO)-43, FRONT SIDE BELT, REMOVAL, V-belt.> or <Ref. to ME(H4DOTC)-45, FRONT SIDE BELT, REMOVAL, V-belt.>

5) Remove the bolts which install generator onto bracket.

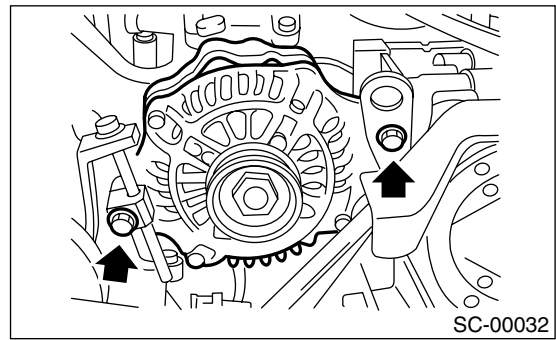

B: INSTALLATION

Install in the reverse order of removal.

CAUTION:

Check and adjust the V-belt tension. <Ref. to ME(H4SO)-44, INSPECTION, V-belt.> or <Ref. to ME(H4DOTC)-46, INSPECTION, V-belt.>

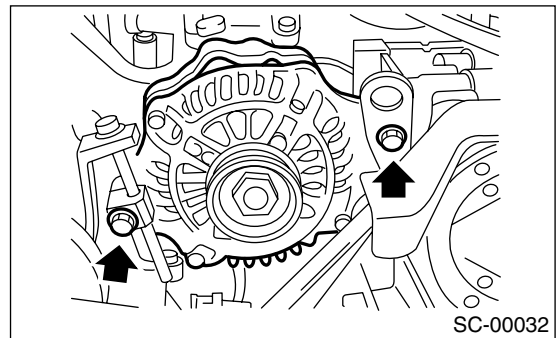

C: DISASSEMBLY

1) Remove the four through-bolts.

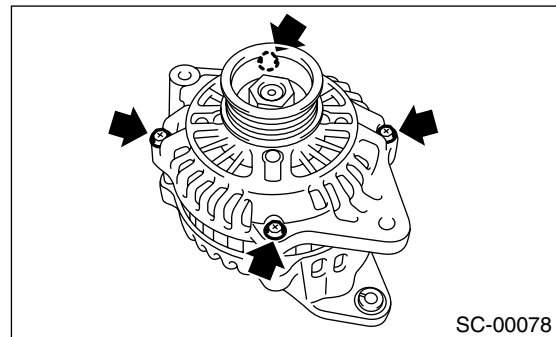

GENERATOR

STARTING/CHARGING SYSTEMS

2) Heat the portion (A) of rear cover to 50°C (122°F) with heater drier.

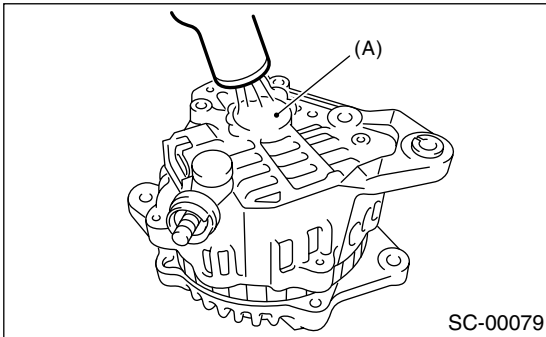

3) Then insert the tip of a flat tip screwdriver into the gap between stator core and front cover. Pry them apart to disassemble.

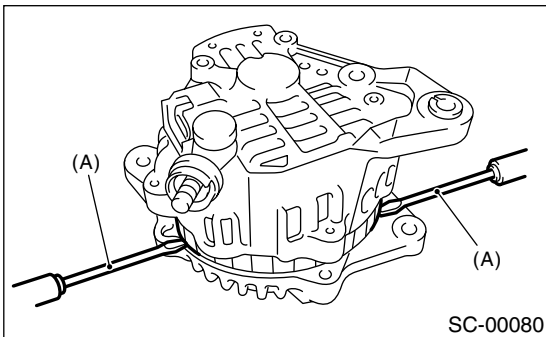

(A) Screwdriver

4) Hold the rotor with a vise and remove pulley nut.

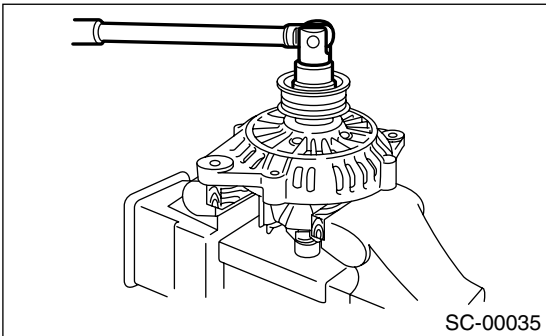

CAUTION:

When holding the rotor with vise, insert aluminum plates or wood pieces on the contact surfaces of vise to prevent rotor from damage.

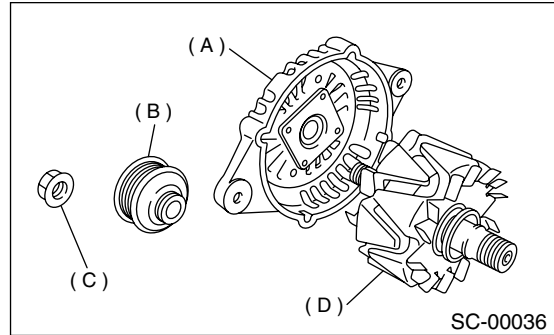

- (A) Front cover
- (B) Pulley
- (C) Nut
- (D) Rotor

5) Remove the ball bearing as follows.

(1) Remove the bolt, and then remove the bearing retainer.

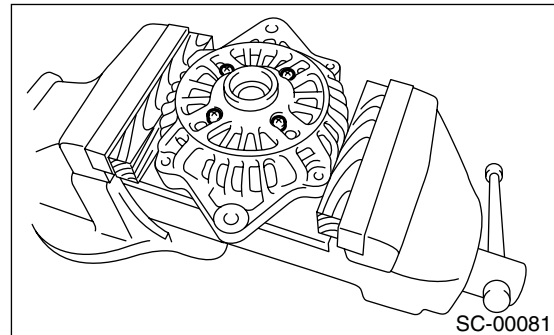

(2) Firmly install an appropriate tool (such as a fit socket wrench) to bearing inner race.

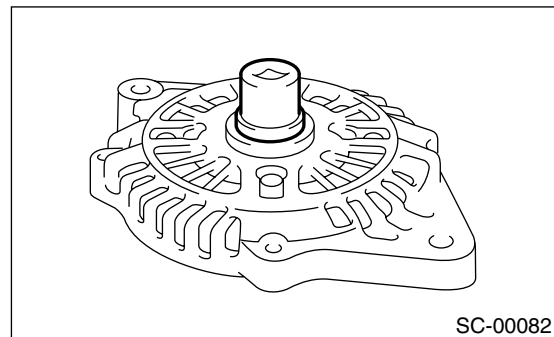

(3) Push the ball bearing off the front cover using a press.

GENERATOR

STARTING/CHARGING SYSTEMS

6) Remove the bearing from rotor using a bearing puller.

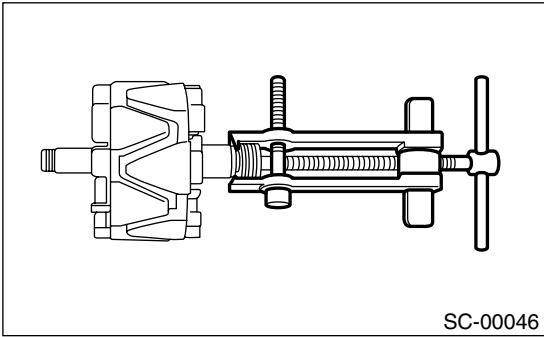

7) Unsolder connection between rectifier and stator coil to remove the stator coil.

CAUTION:

Do not allow the 180 — 270 W soldering bit to contact the terminals for more than 5 seconds at a time because the rectifier cannot withstand heat very well.

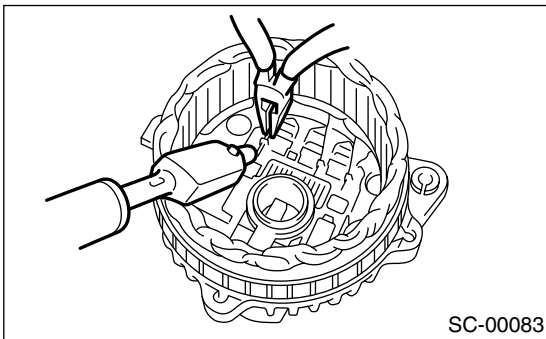

8) Remove the IC regulator as follows.

(1) Remove the screws which secure IC regulator to rear cover.

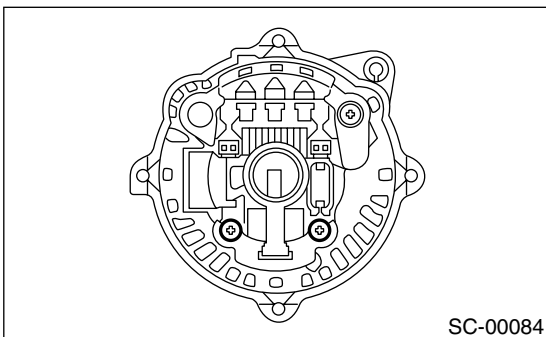

(2) Unsolder the connection between IC regulator and rectifier to remove the IC regulator.

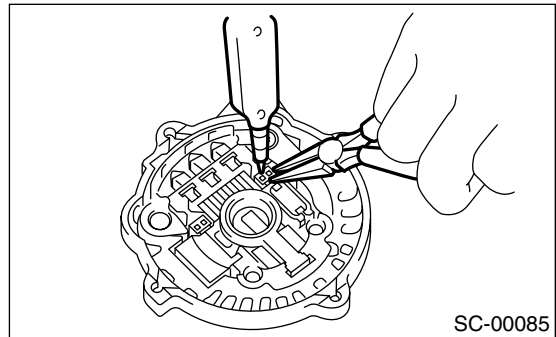

9) Remove the brush as follows.

(1) Remove cover A.

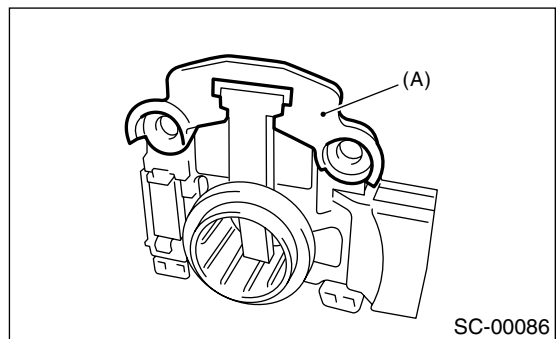

(A) Cover A

(2) Remove the cover B.

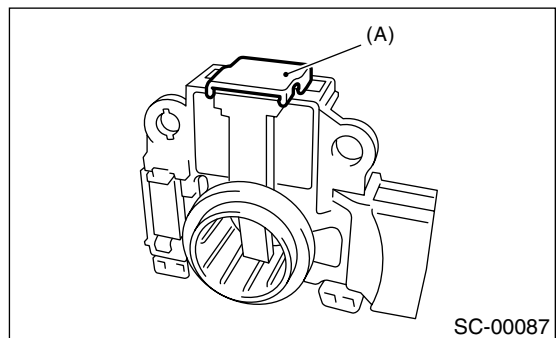

(A) Cover B

(3) Separate the brush from connection to remove.

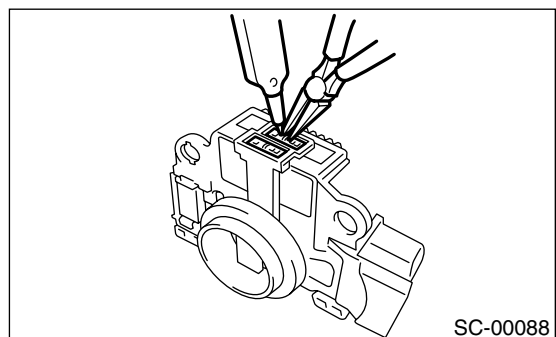

GENERATOR

STARTING/CHARGING SYSTEMS

10) Remove the rectifier as follows.

(1) Remove the bolts which secure the rectifier.

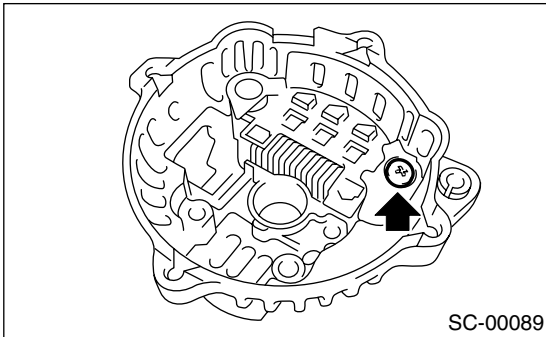

(2) Remove the cover of terminal B.

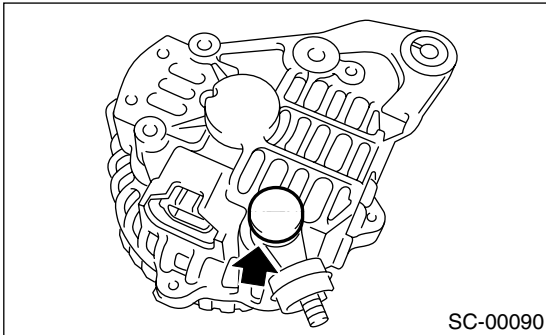

(3) Remove the nut of terminal B, and then remove the rectifier.

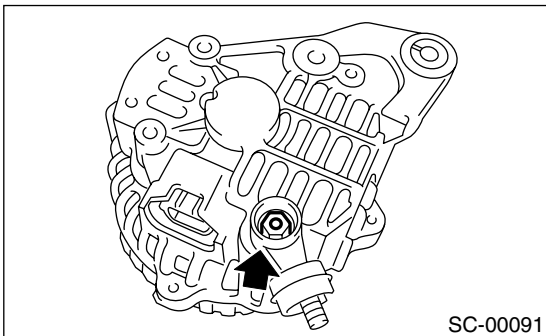

D: ASSEMBLY

To assemble, reverse order of disassembly.

1) Pulling up brush

Before assembling, press the brush down into brush holder, and then fix them in that position by passing a [1 mm (0.08 in) dia. length 4 to 5 cm (1.6 to 2.0 in)] wire through the hole shown in the figure.

CAUTION:

Be sure to remove the wire after reassembly.

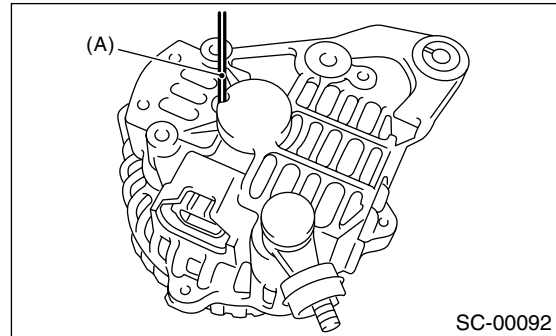

(A) Wire

2) Install the ball bearing.

(1) Set the ball bearing on the front cover, and then securely install an appropriate tool (such as a fit socket wrench) to the bearing outer race.

(2) Press the ball bearing into the specified position using a press.

(3) Install the bearing retainer.

3) Press the bearing (rear side) into the rotor shaft using a press to install.

4) Heat the bearing box in rear cover [50 to 60°C (122 to 140°F)], and then press the rear bearing into rear cover.

CAUTION:

Grease should not be applied to rear bearing. Remove the oil completely if it is found on bearing box.

5) After reassembly, turn the pulley by hand to check that rotor turns smoothly.

E: INSPECTION

1. DIODE

CAUTION:

Never use a mega tester (measuring use for high voltage) or any other similar measure for this test; otherwise, the diodes may be damaged.

1) Checking positive diode

Check for continuity between the diode lead and positive side heat sink. The positive diode is in good condition if resistance is $1\ \Omega$ or less only in the direction from the diode lead to heat sink.

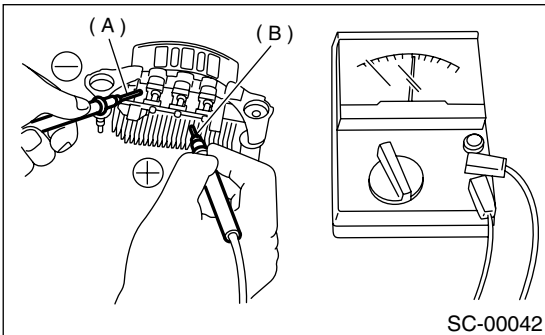

- (A) Diode lead
- (B) Heat sink (Positive side)

2) Checking negative diode

Check for continuity between the negative side heat sink and diode lead. The negative diode is in good condition if resistance is $1\ \Omega$ or less only in the direction from the heat sink to diode lead.

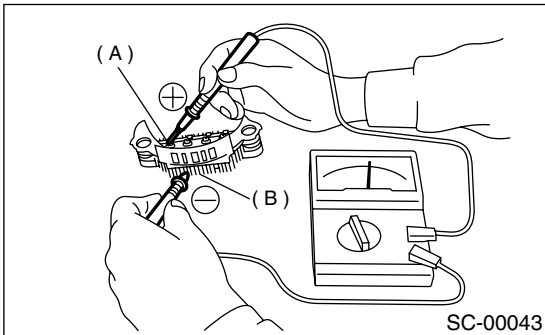

- (A) Diode lead
- (B) Heat sink (Negative side)

2. ROTOR

1) Slip ring surface

Inspect the slip rings for contamination or any roughness of the sliding surface. Repair the slip ring surface using a lathe or sand paper.

2) Slip ring outer diameter

Measure the slip ring outer diameter. If the slip ring is worn replace rotor assembly.

Slip ring outer diameter:

Standard

22.7 mm (0.894 in)

Limit

22.1 mm (0.870 in)

3) Continuity test

Check the resistance between slip rings using circuit tester.

If the resistance is not within specification, replace the rotor assembly.

Specified resistance:

Approx. 1.8 — 2.2 Ω

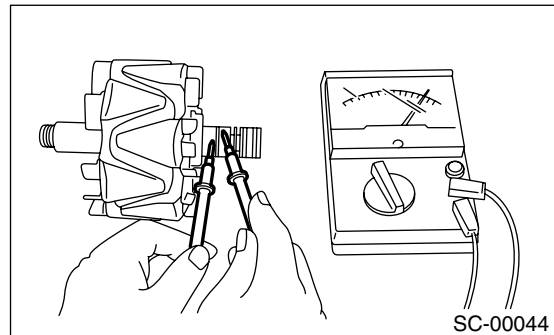

4) Insulation test

Check the continuity between slip ring and rotor core or shaft. If resistance is $1\ \Omega$ or less, the rotor coil is grounded, and so replace the rotor assembly.

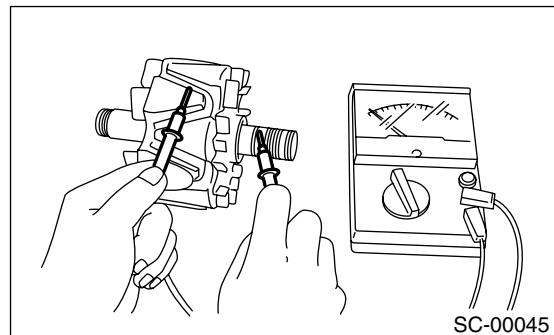

5) Ball bearing (rear side)

Check the rear ball bearing. Replace if it is noisy or if the rotor does not turn smoothly.

GENERATOR

STARTING/CHARGING SYSTEMS

3. STATOR

1) Continuity test

Inspect the stator coil for continuity between each end of the lead wires. If resistance is $1\text{ M}\Omega$ or more, the lead wire is broken, and so replace the stator assembly.

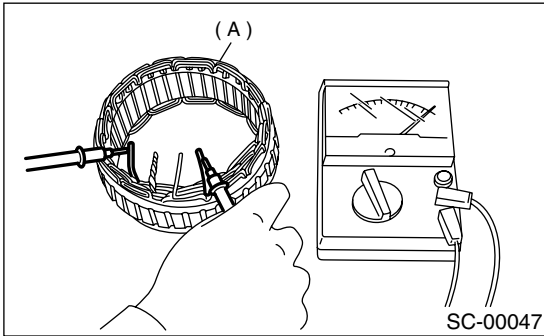

(A) Stator

2) Insulation test

Inspect the stator coil for continuity between stator core and each end of lead wire. If resistance is $1\ \Omega$ or less, the stator coil is grounded, and so replace the stator assembly.

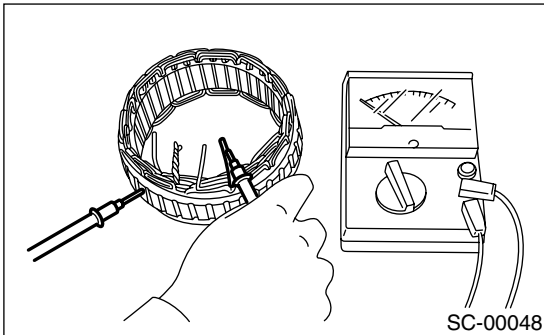

4. BRUSH

1) Measure the length of each brush. If wear exceeds the service limit, replace the brush. Each brush has the service limit mark (A) on it.

Brush length:

Standard

18.5 mm (0.728 in)

Service limit

5.0 mm (0.197 in)

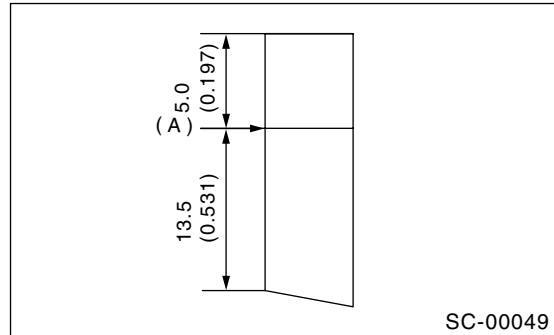

2) Checking brush spring for proper pressure

Using a spring pressure indicator, push the brush into the brush holder until its tip protrudes 2 mm (0.08 in). Then measure the pressure of brush spring. If the pressure is less than 2.2 N (224 g, 7.91 oz), replace the brush spring with a new one. The new spring must have a pressure of 4.8 to 6.0 N (489 to 612 g, 17.26 to 21.60 oz).

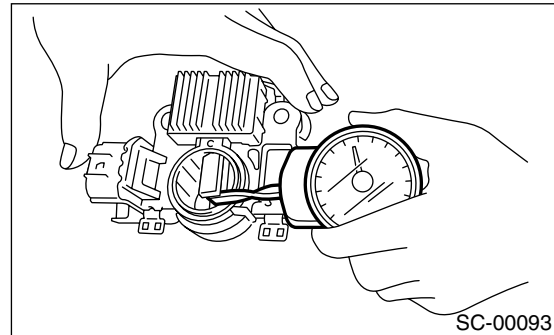

5. BEARING (FRONT SIDE)

Check the front ball bearing. If the resistance is felt while rotating, or if abnormal noise is heard, replace the ball bearing.

4. Battery

A: REMOVAL

1) Remove battery cable holder (A) from battery rod.

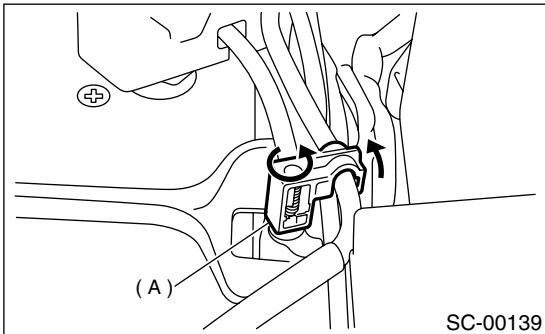

2) Disconnect the positive (+) cable after disconnecting the negative (-) cable of battery.
 3) Remove flange nuts from battery rods and take off battery holder.

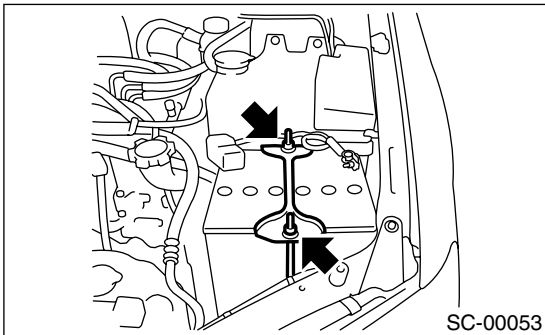

4) Remove battery.

B: INSTALLATION

Install in the reverse order of removal.

Tightening torque:

3.4 N·m (0.35 kgf·m, 2.5 ft·lb)

NOTE:

- Clean battery cable terminals and apply grease to prevent corrosion.
- Connect the positive (+) cable of battery and then the negative (-) cable of the battery.

C: INSPECTION

WARNING:

- Electrolyte has toxicity; be careful handling the fluid.
- Avoid contact with skin, eyes or clothing. Especially at contact with eyes, flush with water for 15 minutes and get prompt medical attention.
- Batteries produce explosive gases. Keep sparks, flame, cigarettes away.
- Ventilate when charging or using in enclosed space.

- For safety, in case an explosion does occur, wear eye protection or shield your eyes when working near any battery. Never lean over a battery.
- Do not let battery fluid contact eyes, skin, fabrics, or paint-work because battery fluid is corrosive acid.
- To lessen the risk of sparks, remove rings, metal watch-bands, and other metal jewelry. Never allow metal tools to contact the positive battery terminal and anything connected to it while you are at the same time in contact with any other metallic portion of the vehicle because a short circuit will be caused.

1. EXTERNAL PARTS:

Check for the existence of dirt or cracks on the battery case, top cover, vent plugs, and terminal posts. If necessary, clean with water and wipe with a dry cloth.

Apply a thin coat of grease on the terminal posts to prevent corrosion.

2. ELECTROLYTE LEVEL:

Check the electrolyte level in each cell. If the level is below MIN LEVEL, bring the level to MAX LEVEL by pouring distilled water into the battery cell. Do not fill beyond MAX LEVEL.

3. SPECIFIC GRAVITY OF ELECTROLYTE:

1) Measure specific gravity of electrolyte using a hydrometer and a thermometer.

Specific gravity varies with temperature of electrolyte so that it must be corrected at 20°C (68°F) using the following equation:

$$S_{20} = St + 0.0007 \times (t - 20)$$

S₂₀: Specific gravity corrected at electrolyte temperature of 20°C

St: Measured specific gravity

t: Measured temperature (°C)

Determine whether or not battery must be charged, according to corrected specific gravity.

Standard specific gravity: 1.220 — 1.290 [at 20°C (68°F)]

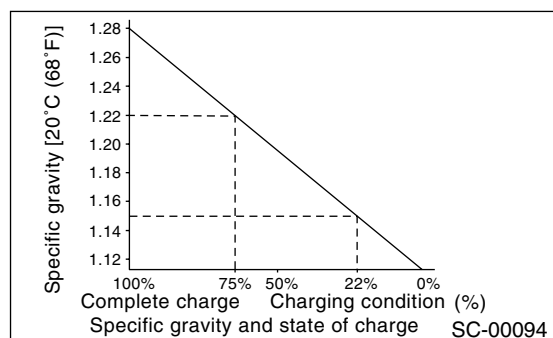

BATTERY

STARTING/CHARGING SYSTEMS

2) Measuring the specific gravity of the electrolyte in the battery will disclose the state of charge of the battery. The relation between the specific gravity and the state of charge is as shown in figure.

D: MEASUREMENT

WARNING:

• Do not bring an open flame close to the battery at this time.

CAUTION:

- Prior to charging, corroded terminals should be cleaned with a brush and common baking soda solution.
- Be careful since battery electrolyte overflows while charging the battery.
- Observe instructions when handling battery charger.
- Before charging the battery on vehicle, disconnect battery ground terminal. Failure to follow this rule may damage alternator's diodes or other electrical units.

1. JUDGMENT OF BATTERY IN CHARGED CONDITION

1) Specific gravity of electrolyte is held at a specific value in a range from 1.250 to 1.290 for more than one hour.

2) Voltage per battery cell is held at a specific value in a range from 2.5 to 2.8 volts for more than one hour.

2. CHECK HYDROMETER FOR STATE OF CHARGE

Hydrometer indicator	State of charge	Required action
Green dot	Above 65%	Load test
Dark dot	Below 65%	Charge battery
Clear dot	Low electrolyte	Replace battery* (If cranking complaint)

*: Check electrical system before replacement.

3. NORMAL CHARGING

Charge the battery at current value specified by manufacturer or at approximately 1/10 of battery's ampere-hour rating.

4. QUICK CHARGING

Quick charging is a method in which the battery is charged in a short period of time with a relatively large current by using a quick charger.

Since a large current flow raises electrolyte temperature, the battery is subject to damage if the large current is used for prolonged time. For this reason, the quick charging must be carried out within a current range that will not increase the electrolyte temperature above 40°C (104°F).

It should be also remembered that the quick charging is a temporary means to bring battery voltage up to a fair value and, as a rule, a battery should be charged slowly with a low current.

CAUTION:

Never use more than 10 amperes when charging the battery because that will shorten battery life.