

# GENERAL DESCRIPTION

# *GD(H4SO)*

---

	<b>Page</b>
1. List of Diagnostic Trouble Code (DTC) .....	2
2. Diagnostic Trouble Code (DTC) Detecting Criteria .....	10



# LIST OF DIAGNOSTIC TROUBLE CODE (DTC)

## GENERAL DESCRIPTION

### 1. List of Diagnostic Trouble Code (DTC)

#### A: List

DTC	Item	Index
P0030	HO2S Heater Control Circuit (Bank 1 Sensor 1)	<Ref. to GD(H4SO)-10, DTC P0030 — HO2S HEATER CONTROL CIRCUIT (BANK 1 SENSOR 1) —, Diagnostic Trouble Code (DTC) Detecting Criteria.>
P0031	HO2S Heater Control Circuit Low (Bank 1 Sensor 1)	<Ref. to GD(H4SO)-12, DTC P0031 — HO2S HEATER CONTROL CIRCUIT LOW (BANK 1 SENSOR 1) —, Diagnostic Trouble Code (DTC) Detecting Criteria.>
P0032	HO2S Heater Control Circuit High (Bank 1 Sensor 1)	<Ref. to GD(H4SO)-14, DTC P0032 — HO2S HEATER CONTROL CIRCUIT HIGH (BANK 1 SENSOR 1) —, Diagnostic Trouble Code (DTC) Detecting Criteria.>
P0037	HO2S Heater Control Circuit Low (Bank 1 Sensor 2)	<Ref. to GD(H4SO)-16, DTC P0037 — HO2S HEATER CONTROL CIRCUIT LOW (BANK 1 SENSOR 2) —, Diagnostic Trouble Code (DTC) Detecting Criteria.>
P0038	HO2S Heater Control Circuit High (Bank 1 Sensor 2)	<Ref. to GD(H4SO)-18, DTC P0038 — HO2S HEATER CONTROL CIRCUIT HIGH (BANK 1 SENSOR 2) —, Diagnostic Trouble Code (DTC) Detecting Criteria.>
P0065	Air Assisted Injector Control Range/Performance	<Ref. to GD(H4SO)-20, DTC P0065 — AIR ASSISTED INJECTOR CONTROL RANGE/PERFORMANCE —, Diagnostic Trouble Code (DTC) Detecting Criteria.>
P0066	Air Assisted Injector Control Circuit or Circuit Low	<Ref. to GD(H4SO)-24, DTC P0066 — AIR ASSISTED INJECTOR CONTROL CIRCUIT OR CIRCUIT LOW —, Diagnostic Trouble Code (DTC) Detecting Criteria.>
P0067	Air Assisted Injector Control Circuit High	<Ref. to GD(H4SO)-26, DTC P0067 — AIR ASSISTED INJECTOR CONTROL CIRCUIT HIGH —, Diagnostic Trouble Code (DTC) Detecting Criteria.>
P0068	Manifold Pressure Sensor Range/Performance	<Ref. to GD(H4SO)-28, DTC P0068 — MANIFOLD PRESSURE SENSOR RANGE/PERFORMANCE —, Diagnostic Trouble Code (DTC) Detecting Criteria.>
P0107	Manifold Absolute Pressure/Barometric Pressure Circuit Low Input	<Ref. to GD(H4SO)-30, DTC P0107 — MANIFOLD ABSOLUTE PRESSURE/BAROMETRIC PRESSURE CIRCUIT LOW INPUT —, Diagnostic Trouble Code (DTC) Detecting Criteria.>
P0108	Manifold Absolute Pressure/Barometric Pressure Circuit High Input	<Ref. to GD(H4SO)-32, DTC P0108 — MANIFOLD ABSOLUTE PRESSURE/BAROMETRIC PRESSURE CIRCUIT HIGH INPUT —, Diagnostic Trouble Code (DTC) Detecting Criteria.>
P0111	Intake Air Temperature Circuit Range/Performance	<Ref. to GD(H4SO)-34, DTC P0111 — INTAKE AIR TEMPERATURE CIRCUIT RANGE/PERFORMANCE —, Diagnostic Trouble Code (DTC) Detecting Criteria.>
P0112	Intake Air Temperature Circuit Low Input	<Ref. to GD(H4SO)-36, DTC P0112 — INTAKE AIR TEMPERATURE CIRCUIT LOW INPUT —, Diagnostic Trouble Code (DTC) Detecting Criteria.>
P0113	Intake Air Temperature Circuit High Input	<Ref. to GD(H4SO)-38, DTC P0113 — INTAKE AIR TEMPERATURE CIRCUIT HIGH INPUT —, Diagnostic Trouble Code (DTC) Detecting Criteria.>
P0117	Engine Coolant Temperature Circuit Low Input	<Ref. to GD(H4SO)-40, DTC P0117 — ENGINE COOLANT TEMPERATURE CIRCUIT LOW INPUT —, Diagnostic Trouble Code (DTC) Detecting Criteria.>
P0118	Engine Coolant Temperature Circuit High Input	<Ref. to GD(H4SO)-42, DTC P0118 — ENGINE COOLANT TEMPERATURE CIRCUIT HIGH INPUT —, Diagnostic Trouble Code (DTC) Detecting Criteria.>
P0121	Throttle/Pedal Position Sensor/Switch "A" Circuit Range/Performance	<Ref. to GD(H4SO)-44, DTC P0121 — THROTTLE/PEDAL POSITION SENSOR/SWITCH "A" CIRCUIT RANGE/PERFORMANCE —, Diagnostic Trouble Code (DTC) Detecting Criteria.>
P0122	Throttle/Pedal Position Sensor/Switch "A" Circuit Low Input	<Ref. to GD(H4SO)-48, DTC P0122 — THROTTLE/PEDAL POSITION SENSOR/SWITCH "A" CIRCUIT LOW INPUT —, Diagnostic Trouble Code (DTC) Detecting Criteria.>

# LIST OF DIAGNOSTIC TROUBLE CODE (DTC)

GENERAL DESCRIPTION

DTC	Item	Index
P0123	Throttle/Pedal Position Sensor/ Switch "A" Circuit High Input	<Ref. to GD(H4SO)-50, DTC P0123 — THROTTLE/PEDAL POSITION SENSOR/SWITCH "A" CIRCUIT HIGH INPUT —, Diagnostic Trouble Code (DTC) Detecting Criteria.>
P0125	Insufficient Coolant Temperature For Closed Loop Fuel Control	<Ref. to GD(H4SO)-52, DTC P0125 — INSUFFICIENT COOLANT TEMPERATURE FOR CLOSED LOOP FUEL CONTROL —, Diagnostic Trouble Code (DTC) Detecting Criteria.>
P0128	Coolant Thermostat (Coolant Tem- perature Below Thermostat Regulat- ing Temperature)	<Ref. to GD(H4SO)-54, DTC P0128 — COOLANT THERMOSTAT (COOLANT TEMPERATURE BELOW THERMOSTAT REGULATING TEMPERATURE) —, Diagnostic Trouble Code (DTC) Detecting Criteria.>
P0129	Barometric Pressure Too Low	<Ref. to GD(H4SO)-56, DTC P0129 — BAROMETRIC PRESSURE TOO LOW —, Diagnostic Trouble Code (DTC) Detecting Criteria.>
P0130	O <sub>2</sub> Sensor Circuit (Bank 1 Sensor 1)	<Ref. to GD(H4SO)-58, DTC P0130 — O <sub>2</sub> SENSOR CIRCUIT (BANK 1 SENSOR 1) —, Diagnostic Trouble Code (DTC) Detecting Criteria.>
P0131	O <sub>2</sub> Sensor Circuit Low Voltage (Bank 1 Sensor 1)	<Ref. to GD(H4SO)-60, DTC P0131 — O <sub>2</sub> SENSOR CIRCUIT LOW VOLTAGE (BANK 1 SENSOR 1) —, Diagnostic Trouble Code (DTC) Detecting Criteria.>
P0132	O <sub>2</sub> Sensor Circuit High Voltage (Bank 1 Sensor 1)	<Ref. to GD(H4SO)-62, DTC P0132 — O <sub>2</sub> SENSOR CIRCUIT HIGH VOLTAGE (BANK 1 SENSOR 1) —, Diagnostic Trouble Code (DTC) Detecting Criteria.>
P0133	O <sub>2</sub> Sensor Circuit Slow Response (Bank 1 Sensor 1)	<Ref. to GD(H4SO)-64, DTC P0133 — O <sub>2</sub> SENSOR CIRCUIT SLOW RESPONSE (BANK 1 SENSOR 1) —, Diagnostic Trouble Code (DTC) Detecting Criteria.>
P0134	O <sub>2</sub> Sensor Circuit No Activity Detected (Bank 1 Sensor 1)	<Ref. to GD(H4SO)-68, DTC P0134 — O <sub>2</sub> SENSOR CIRCUIT NO ACTIVITY DETECTED (BANK 1 SENSOR 1) —, Diagnostic Trouble Code (DTC) Detecting Criteria.>
P0137	O <sub>2</sub> Sensor Circuit Low Voltage (Bank 1 Sensor 2)	<Ref. to GD(H4SO)-70, DTC P0137 — O <sub>2</sub> SENSOR CIRCUIT LOW VOLTAGE (BANK 1 SENSOR 2) —, Diagnostic Trouble Code (DTC) Detecting Criteria.>
P0138	O <sub>2</sub> Sensor Circuit High Voltage (Bank 1 Sensor 2)	<Ref. to GD(H4SO)-72, DTC P0138 — O <sub>2</sub> SENSOR CIRCUIT HIGH VOLTAGE (BANK 1 SENSOR 2) —, Diagnostic Trouble Code (DTC) Detecting Criteria.>
P0139	O <sub>2</sub> Sensor Circuit Slow Response (Bank 1 Sensor 2)	<Ref. to GD(H4SO)-74, DTC P0139 — O <sub>2</sub> SENSOR CIRCUIT SLOW RESPONSE (BANK 1 SENSOR 2) —, Diagnostic Trouble Code (DTC) Detecting Criteria.>
P0171	System Too Lean (Bank 1)	<Ref. to GD(H4SO)-78, DTC P0171 — SYSTEM TOO LEAN (BANK 1) —, Diagnostic Trouble Code (DTC) Detecting Criteria.>
P0172	System Too Rich (Bank 1)	<Ref. to GD(H4SO)-80, DTC P0172 — SYSTEM TOO RICH (BANK 1) —, Diagnostic Trouble Code (DTC) Detecting Criteria.>
P0181	Fuel Temperature Sensor "A" Circuit Range/Performance	<Ref. to GD(H4SO)-82, DTC P0181 — FUEL TEMPERATURE SENSOR "A" CIRCUIT RANGE/PERFORMANCE —, Diagnostic Trouble Code (DTC) Detecting Criteria.>
P0182	Fuel Temperature Sensor "A" Circuit Low Input	<Ref. to GD(H4SO)-84, DTC P0182 — FUEL TEMPERATURE SENSOR "A" CIRCUIT LOW INPUT —, Diagnostic Trouble Code (DTC) Detecting Criteria.>
P0183	Fuel Temperature Sensor "A" Circuit High Input	<Ref. to GD(H4SO)-86, DTC P0183 — FUEL TEMPERATURE SENSOR "A" CIRCUIT HIGH INPUT —, Diagnostic Trouble Code (DTC) Detecting Criteria.>
P0301	Cylinder 1 Misfire Detected	<Ref. to GD(H4SO)-88, DTC P0301 — CYLINDER 1 MISFIRE DETECTED —, Diagnostic Trouble Code (DTC) Detecting Criteria.>
P0302	Cylinder 2 Misfire Detected	<Ref. to GD(H4SO)-94, DTC P0302 — CYLINDER 2 MISFIRE DETECTED —, Diagnostic Trouble Code (DTC) Detecting Criteria.>
P0303	Cylinder 3 Misfire Detected	<Ref. to GD(H4SO)-94, DTC P0303 — CYLINDER 3 MISFIRE DETECTED —, Diagnostic Trouble Code (DTC) Detecting Criteria.>
P0304	Cylinder 4 Misfire Detected	<Ref. to GD(H4SO)-94, DTC P0304 — CYLINDER 4 MISFIRE DETECTED —, Diagnostic Trouble Code (DTC) Detecting Criteria.>

# LIST OF DIAGNOSTIC TROUBLE CODE (DTC)

## GENERAL DESCRIPTION

DTC	Item	Index
P0327	Knock Sensor 1 Circuit Low Input (Bank 1 or Single Sensor)	<Ref. to GD(H4SO)-96, DTC P0327 — KNOCK SENSOR 1 CIRCUIT LOW INPUT (BANK 1 OR SINGLE SENSOR) —, Diagnostic Trouble Code (DTC) Detecting Criteria.>
P0328	Knock Sensor 1 Circuit High Input (Bank 1 or Single Sensor)	<Ref. to GD(H4SO)-98, DTC P0328 — KNOCK SENSOR 1 CIRCUIT HIGH INPUT (BANK 1 OR SINGLE SENSOR) —, Diagnostic Trouble Code (DTC) Detecting Criteria.>
P0335	Crankshaft Position Sensor “A” Circuit	<Ref. to GD(H4SO)-100, DTC P0335 — CRANKSHAFT POSITION SENSOR “A” CIRCUIT —, Diagnostic Trouble Code (DTC) Detecting Criteria.>
P0336	Crankshaft Position Sensor “A” Circuit Range/Performance	<Ref. to GD(H4SO)-102, DTC P0336 — CRANKSHAFT POSITION SENSOR “A” CIRCUIT RANGE/PERFORMANCE —, Diagnostic Trouble Code (DTC) Detecting Criteria.>
P0340	Camshaft Position Sensor “A” Circuit (Bank 1 or Single Sensor)	<Ref. to GD(H4SO)-104, DTC P0340 — CAMSHAFT POSITION SENSOR “A” CIRCUIT (BANK 1 OR SINGLE SENSOR) —, Diagnostic Trouble Code (DTC) Detecting Criteria.>
P0341	Camshaft Position Sensor “A” Circuit Range/Performance (Bank 1 or Single Sensor)	<Ref. to GD(H4SO)-106, DTC P0341 — CAMSHAFT POSITION SENSOR “A” CIRCUIT RANGE/PERFORMANCE (BANK 1 OR SINGLE SENSOR) —, Diagnostic Trouble Code (DTC) Detecting Criteria.>
P0400	EGR System	<Ref. to GD(H4SO)-108, DTC P0400 — EXHAUST GAS RECIRCULATION FLOW —, Diagnostic Trouble Code (DTC) Detecting Criteria.>
P0420	Catalyst System Efficiency Below Threshold (Bank 1)	<Ref. to GD(H4SO)-112, DTC P0420 — CATALYST SYSTEM EFFICIENCY BELOW THRESHOLD (BANK 1) —, Diagnostic Trouble Code (DTC) Detecting Criteria.>
P0442	Evaporative Emission Control System Leak Detected (Small Leak)	<Ref. to GD(H4SO)-116, DTC P0442 — EVAPORATIVE EMISSION CONTROL SYSTEM LEAK DETECTED (SMALL LEAK) —, Diagnostic Trouble Code (DTC) Detecting Criteria.>
P0447	Evaporative Emission Control System Vent Control Circuit Open	<Ref. to GD(H4SO)-140, DTC P0447 — EVAPORATIVE EMISSION CONTROL SYSTEM VENT CONTROL CIRCUIT OPEN —, Diagnostic Trouble Code (DTC) Detecting Criteria.>
P0448	Evaporative Emission Control System Vent Control Circuit Shorted	<Ref. to GD(H4SO)-142, DTC P0448 — EVAPORATIVE EMISSION CONTROL SYSTEM VENT CONTROL CIRCUIT SHORTED —, Diagnostic Trouble Code (DTC) Detecting Criteria.>
P0451	Evaporative Emission Control System Pressure Sensor Range/Performance	<Ref. to GD(H4SO)-144, DTC P0451 — EVAPORATIVE EMISSION CONTROL SYSTEM PRESSURE SENSOR RANGE/PERFORMANCE —, Diagnostic Trouble Code (DTC) Detecting Criteria.>
P0452	Evaporative Emission Control System Pressure Sensor Low Input	<Ref. to GD(H4SO)-148, DTC P0452 — EVAPORATIVE EMISSION CONTROL SYSTEM PRESSURE SENSOR LOW INPUT —, Diagnostic Trouble Code (DTC) Detecting Criteria.>
P0453	Evaporative Emission Control System Pressure Sensor High Input	<Ref. to GD(H4SO)-150, DTC P0453 — EVAPORATIVE EMISSION CONTROL SYSTEM PRESSURE SENSOR HIGH INPUT —, Diagnostic Trouble Code (DTC) Detecting Criteria.>
P0456	Evaporative Emission Control System Leak Detected (Very Small Leak)	<Ref. to GD(H4SO)-152, DTC P0456 — EVAPORATIVE EMISSION CONTROL SYSTEM LEAK DETECTED (VERY SMALL LEAK) —, Diagnostic Trouble Code (DTC) Detecting Criteria.>
P0457	Evaporative Emission Control System Leak Detected (Fuel Cap Loose/Off)	<Ref. to GD(H4SO)-152, DTC P0457 — EVAPORATIVE EMISSION CONTROL SYSTEM LEAK DETECTED (FUEL CAP LOOSE/OFF) —, Diagnostic Trouble Code (DTC) Detecting Criteria.>
P0458	Evaporative Emission Control System Purge Control Valve Circuit Low	<Ref. to GD(H4SO)-154, DTC P0458 — EVAPORATIVE EMISSION CONTROL SYSTEM PURGE CONTROL VALVE CIRCUIT —, Diagnostic Trouble Code (DTC) Detecting Criteria.>
P0459	Evaporative Emission Control System Purge Control Valve Circuit High	<Ref. to GD(H4SO)-156, DTC P0459 — EVAPORATIVE EMISSION CONTROL SYSTEM PURGE CONTROL VALVE CIRCUIT HIGH —, Diagnostic Trouble Code (DTC) Detecting Criteria.>
P0461	Fuel Level Sensor Circuit Range/Performance	<Ref. to GD(H4SO)-158, DTC P0461 — FUEL LEVEL SENSOR CIRCUIT RANGE/PERFORMANCE —, Diagnostic Trouble Code (DTC) Detecting Criteria.>
P0462	Fuel Level Sensor Circuit Low Input	<Ref. to GD(H4SO)-160, DTC P0462 — FUEL LEVEL SENSOR CIRCUIT LOW INPUT —, Diagnostic Trouble Code (DTC) Detecting Criteria.>

# LIST OF DIAGNOSTIC TROUBLE CODE (DTC)

GENERAL DESCRIPTION

DTC	Item	Index
P0463	Fuel Level Sensor Circuit High Input	<Ref. to GD(H4SO)-162, DTC P0463 — FUEL LEVEL SENSOR CIRCUIT HIGH INPUT —, Diagnostic Trouble Code (DTC) Detecting Criteria.>
P0464	Fuel Level Sensor Circuit Intermittent	<Ref. to GD(H4SO)-164, DTC P0464 — FUEL LEVEL SENSOR CIRCUIT INTERMITTENT —, Diagnostic Trouble Code (DTC) Detecting Criteria.>
P0483	Cooling Fan Rationality Check	<Ref. to GD(H4SO)-168, DTC P0483 — COOLING FAN RATIONALITY CHECK —, Diagnostic Trouble Code (DTC) Detecting Criteria.>
P0502	Vehicle Speed Sensor Circuit Low Input	<Ref. to GD(H4SO)-170, DTC P0502 — VEHICLE SPEED SENSOR CIRCUIT LOW INPUT —, Diagnostic Trouble Code (DTC) Detecting Criteria.>
P0503	Vehicle Speed Sensor Intermittent/Erratic/High	<Ref. to GD(H4SO)-171, DTC P0503 — VEHICLE SPEED SENSOR INTERMITTENT/ERRATIC/HIGH —, Diagnostic Trouble Code (DTC) Detecting Criteria.>
P0506	Idle Control System RPM Lower Than Expected	<Ref. to GD(H4SO)-172, DTC P0506 — IDLE CONTROL SYSTEM RPM LOWER THAN EXPECTED —, Diagnostic Trouble Code (DTC) Detecting Criteria.>
P0507	Idle Control System RPM Higher Than Expected	<Ref. to GD(H4SO)-174, DTC P0507 — IDLE CONTROL SYSTEM RPM HIGHER THAN EXPECTED —, Diagnostic Trouble Code (DTC) Detecting Criteria.>
P0512	Starter Request Circuit	<Ref. to GD(H4SO)-176, DTC P0512 — STARTER REQUEST CIRCUIT —, Diagnostic Trouble Code (DTC) Detecting Criteria.>
P0519	Idle Control System Malfunction (Fail-Safe)	<Ref. to GD(H4SO)-177, DTC P0519 — IDLE CONTROL SYSTEM MALFUNCTION (FAIL-SAFE) —, Diagnostic Trouble Code (DTC) Detecting Criteria.>
P0565	Cruise Control On Signal	<Ref. to GD(H4SO)-178, DTC P0565 — CRUISE CONTROL ON SIGNAL —, Diagnostic Trouble Code (DTC) Detecting Criteria.>
P0604	Internal Control Module Random Access Memory (RAM) Error	<Ref. to GD(H4SO)-179, DTC P0604 — INTERNAL CONTROL MODULE RANDOM ACCESS MEMORY (RAM) ERROR —, Diagnostic Trouble Code (DTC) Detecting Criteria.>
P0691	Cooling Fan 1 Control Circuit Low	<Ref. to GD(H4SO)-180, DTC P0691 — COOLING FAN 1 CONTROL CIRCUIT LOW —, Diagnostic Trouble Code (DTC) Detecting Criteria.>
P0692	Cooling Fan 1 Control Circuit High	<Ref. to GD(H4SO)-181, DTC P0692 — COOLING FAN 1 CONTROL CIRCUIT HIGH —, Diagnostic Trouble Code (DTC) Detecting Criteria.>
P0703	Torque Converter/Brake Switch “B” Circuit	<Ref. to GD(H4SO)-182, DTC P0703 — TORQUE CONVERTER/BRAKE SWITCH “B” CIRCUIT —, Diagnostic Trouble Code (DTC) Detecting Criteria.>
P0705	Transmission Range Sensor Circuit (PRNDL Input)	<Ref. to GD(H4SO)-183, DTC P0705 — TRANSMISSION RANGE SENSOR CIRCUIT (PRNDL INPUT) —, Diagnostic Trouble Code (DTC) Detecting Criteria.>
P0710	Transmission Fluid Temperature Sensor Circuit	<Ref. to GD(H4SO)-185, DTC P0710 — TRANSMISSION FLUID TEMPERATURE SENSOR CIRCUIT —, Diagnostic Trouble Code (DTC) Detecting Criteria.>
P0716	Input/Turbine Speed Sensor Circuit Range/Performance	<Ref. to GD(H4SO)-186, DTC P0716 — INPUT/TURBINE SPEED SENSOR CIRCUIT RANGE/PERFORMANCE —, Diagnostic Trouble Code (DTC) Detecting Criteria.>
P0720	Output Speed Sensor Circuit	<Ref. to GD(H4SO)-187, DTC P0720 — OUTPUT SPEED SENSOR CIRCUIT —, Diagnostic Trouble Code (DTC) Detecting Criteria.>
P0726	Engine Speed Input Circuit Range/Performance	<Ref. to GD(H4SO)-188, DTC P0726 — ENGINE SPEED INPUT CIRCUIT RANGE/PERFORMANCE —, Diagnostic Trouble Code (DTC) Detecting Criteria.>
P0731	Gear 1 Incorrect Ratio	<Ref. to GD(H4SO)-189, DTC P0731 — GEAR 1 INCORRECT RATIO —, Diagnostic Trouble Code (DTC) Detecting Criteria.>
P0732	Gear 2 Incorrect Ratio	<Ref. to GD(H4SO)-190, DTC P0732 — GEAR 2 INCORRECT RATIO —, Diagnostic Trouble Code (DTC) Detecting Criteria.>
P0733	Gear 3 Incorrect Ratio	<Ref. to GD(H4SO)-191, DTC P0733 — GEAR 3 INCORRECT RATIO —, Diagnostic Trouble Code (DTC) Detecting Criteria.>
P0734	Gear 4 Incorrect Ratio	<Ref. to GD(H4SO)-192, DTC P0734 — GEAR 4 INCORRECT RATIO —, Diagnostic Trouble Code (DTC) Detecting Criteria.>

# LIST OF DIAGNOSTIC TROUBLE CODE (DTC)

## GENERAL DESCRIPTION

DTC	Item	Index
P0741	Torque Converter Clutch Circuit Performance or Stuck Off	<Ref. to GD(H4SO)-193, DTC P0741 — TORQUE CONVERTER CLUTCH CIRCUIT PERFORMANCE OR STUCK OFF —, Diagnostic Trouble Code (DTC) Detecting Criteria.>
P0743	Torque Converter Clutch Circuit Electrical	<Ref. to GD(H4SO)-194, DTC P0743 — TORQUE CONVERTER CLUTCH CIRCUIT ELECTRICAL —, Diagnostic Trouble Code (DTC) Detecting Criteria.>
P0748	Pressure Control Solenoid "A" Electrical	<Ref. to GD(H4SO)-195, DTC P0748 — PRESSURE CONTROL SOLENOID "A" ELECTRICAL —, Diagnostic Trouble Code (DTC) Detecting Criteria.>
P0753	Shift Solenoid "A" Electrical	<Ref. to GD(H4SO)-196, DTC P0753 — SHIFT SOLENOID "A" ELECTRICAL —, Diagnostic Trouble Code (DTC) Detecting Criteria.>
P0758	Shift Solenoid "B" Electrical	<Ref. to GD(H4SO)-197, DTC P0758 — SHIFT SOLENOID "B" ELECTRICAL —, Diagnostic Trouble Code (DTC) Detecting Criteria.>
P0771	Shift Solenoid "E" Performance or Stuck Off	<Ref. to GD(H4SO)-198, DTC P0771 — SHIFT SOLENOID "E" PERFORMANCE OR STUCK OFF —, Diagnostic Trouble Code (DTC) Detecting Criteria.>
P0778	Pressure Control Solenoid "B" Electrical	<Ref. to GD(H4SO)-199, DTC P0778 — PRESSURE CONTROL SOLENOID "B" ELECTRICAL —, Diagnostic Trouble Code (DTC) Detecting Criteria.>
P0785	Shift/Timing Solenoid	<Ref. to GD(H4SO)-200, DTC P0785 — SHIFT/TIMING SOLENOID —, Diagnostic Trouble Code (DTC) Detecting Criteria.>
P0851	Neutral Switch Input Circuit Low	<Ref. to GD(H4SO)-201, DTC P0851 — NEUTRAL SWITCH INPUT CIRCUIT LOW —, Diagnostic Trouble Code (DTC) Detecting Criteria.>
P0852	Neutral Switch Input Circuit High	<Ref. to GD(H4SO)-204, DTC P0852 — NEUTRAL SWITCH INPUT CIRCUIT HIGH —, Diagnostic Trouble Code (DTC) Detecting Criteria.>
P0864	TCM Communication Circuit Range/Performance	<Ref. to GD(H4SO)-206, DTC P0864 — TCM COMMUNICATION CIRCUIT RANGE/PERFORMANCE —, Diagnostic Trouble Code (DTC) Detecting Criteria.>
P0865	TCM Communication Circuit Low	<Ref. to GD(H4SO)-207, DTC P0865 — TCM COMMUNICATION CIRCUIT LOW —, Diagnostic Trouble Code (DTC) Detecting Criteria.>
P0866	TCM Communication Circuit High	<Ref. to GD(H4SO)-208, DTC P0866 — TCM COMMUNICATION CIRCUIT HIGH —, Diagnostic Trouble Code (DTC) Detecting Criteria.>
P1110	Atmospheric Pressure Sensor Circuit Malfunction (Low Input)	<Ref. to GD(H4SO)-209, DTC P1110 — ATMOSPHERIC PRESSURE SENSOR CIRCUIT MALFUNCTION (LOW INPUT) —, Diagnostic Trouble Code (DTC) Detecting Criteria.>
P1111	Atmospheric Pressure Sensor Circuit Malfunction (High Input)	<Ref. to GD(H4SO)-210, DTC P1111 — ATMOSPHERIC PRESSURE SENSOR CIRCUIT MALFUNCTION (HIGH INPUT) —, Diagnostic Trouble Code (DTC) Detecting Criteria.>
P1134	A/F Sensor Micro-Computer Problem	<Ref. to GD(H4SO)-212, DTC P1134 — A/F SENSOR MICRO-COMPUTER PROBLEM —, Diagnostic Trouble Code (DTC) Detecting Criteria.>
P1137	O <sub>2</sub> Sensor Circuit Low Voltage (Bank 1 Sensor 2)	<Ref. to GD(H4SO)-214, DTC P1137 — O <sub>2</sub> SENSOR CIRCUIT LOW VOLTAGE (BANK 1 SENSOR 2) —, Diagnostic Trouble Code (DTC) Detecting Criteria.>
P1400	Fuel Tank Pressure Control Solenoid Valve Circuit Low	<Ref. to GD(H4SO)-216, DTC P1400 — FUEL TANK PRESSURE CONTROL SOLENOID VALVE CIRCUIT LOW —, Diagnostic Trouble Code (DTC) Detecting Criteria.>
P1420	Fuel Tank Pressure Control Sol. Valve Circuit High	<Ref. to GD(H4SO)-218, DTC P1420 — FUEL TANK PRESSURE CONTROL SOLENOID VALVE CIRCUIT HIGH —, Diagnostic Trouble Code (DTC) Detecting Criteria.>
P1443	Vent Control Solenoid Valve Function Problem	<Ref. to GD(H4SO)-220, DTC P1443 — VENT CONTROL SOLENOID VALVE FUNCTION PROBLEM —, Diagnostic Trouble Code (DTC) Detecting Criteria.>
P1446	Fuel Tank Sensor Control Valve Circuit Low	<Ref. to GD(H4SO)-222, DTC P1446 — FUEL TANK SENSOR CONTROL VALVE CIRCUIT LOW —, Diagnostic Trouble Code (DTC) Detecting Criteria.>

# LIST OF DIAGNOSTIC TROUBLE CODE (DTC)

GENERAL DESCRIPTION

DTC	Item	Index
P1447	Fuel Tank Sensor Control Valve Circuit High	<Ref. to GD(H4SO)-224, DTC P1447 — FUEL TANK SENSOR CONTROL VALVE CIRCUIT HIGH —, Diagnostic Trouble Code (DTC) Detecting Criteria.>
P1448	Fuel Tank Sensor Control Valve Range/Performance	<Ref. to GD(H4SO)-226, DTC P1448 — FUEL TANK SENSOR CONTROL VALVE RANGE/PERFORMANCE—, Diagnostic Trouble Code (DTC) Detecting Criteria.>
P1492	EGR solenoid valve signal #1 circuit malfunction (low input)	<Ref. to GD(H4SO)-230, DTC P1492 — EGR SOLENOID VALVE SIGNAL #1 CIRCUIT MALFUNCTION (LOW INPUT) —, Diagnostic Trouble Code (DTC) Detecting Criteria.>
P1493	EGR solenoid valve signal #1 circuit malfunction (high input)	<Ref. to GD(H4SO)-232, DTC P1493 — EGR SOLENOID VALVE SIGNAL #1 CIRCUIT MALFUNCTION (HIGH INPUT) —, Diagnostic Trouble Code (DTC) Detecting Criteria.>
P1494	EGR solenoid valve signal #2 circuit malfunction (low input)	<Ref. to GD(H4SO)-234, DTC P1494 — EGR SOLENOID VALVE SIGNAL #2 CIRCUIT MALFUNCTION (LOW INPUT) —, Diagnostic Trouble Code (DTC) Detecting Criteria.>
P1495	EGR solenoid valve signal #2 circuit malfunction (high input)	<Ref. to GD(H4SO)-236, DTC P1495 — EGR SOLENOID VALVE SIGNAL #2 CIRCUIT MALFUNCTION (HIGH INPUT) —, Diagnostic Trouble Code (DTC) Detecting Criteria.>
P1496	EGR solenoid valve signal #3 circuit malfunction (low input)	<Ref. to GD(H4SO)-238, DTC P1496 — EGR SOLENOID VALVE SIGNAL #3 CIRCUIT MALFUNCTION (LOW INPUT) —, Diagnostic Trouble Code (DTC) Detecting Criteria.>
P1497	EGR solenoid valve signal #3 circuit malfunction (high input)	<Ref. to GD(H4SO)-240, DTC P1497 — EGR SOLENOID VALVE SIGNAL #3 CIRCUIT MALFUNCTION (HIGH INPUT) —, Diagnostic Trouble Code (DTC) Detecting Criteria.>
P1498	EGR solenoid valve signal #4 circuit malfunction (low input)	<Ref. to GD(H4SO)-242, DTC P1498 — EGR SOLENOID VALVE SIGNAL #4 CIRCUIT MALFUNCTION (LOW INPUT) —, Diagnostic Trouble Code (DTC) Detecting Criteria.>
P1499	EGR solenoid valve signal #4 circuit malfunction (high input)	<Ref. to GD(H4SO)-244, DTC P1499 — EGR SOLENOID VALVE SIGNAL #4 CIRCUIT MALFUNCTION (HIGH INPUT) —, Diagnostic Trouble Code (DTC) Detecting Criteria.>
P1510	ISC Solenoid Valve Signal #1 Circuit Malfunction (Low Input)	<Ref. to GD(H4SO)-246, DTC P1510 — ISC SOLENOID VALVE SIGNAL #1 CIRCUIT MALFUNCTION (LOW INPUT) —, Diagnostic Trouble Code (DTC) Detecting Criteria.>
P1511	ISC Solenoid Valve Signal #1 Circuit Malfunction (High Input)	<Ref. to GD(H4SO)-248, DTC P1511 — ISC SOLENOID VALVE SIGNAL #1 CIRCUIT MALFUNCTION (HIGH INPUT) —, Diagnostic Trouble Code (DTC) Detecting Criteria.>
P1512	ISC Solenoid Valve Signal #2 Circuit Malfunction (Low Input)	<Ref. to GD(H4SO)-250, DTC P1512 — ISC SOLENOID VALVE SIGNAL #2 CIRCUIT MALFUNCTION (LOW INPUT) —, Diagnostic Trouble Code (DTC) Detecting Criteria.>
P1513	ISC Solenoid Valve Signal #2 Circuit Malfunction (High Input)	<Ref. to GD(H4SO)-252, DTC P1513 — ISC SOLENOID VALVE SIGNAL #2 CIRCUIT MALFUNCTION (HIGH INPUT) —, Diagnostic Trouble Code (DTC) Detecting Criteria.>
P1514	ISC Solenoid Valve Signal #3 Circuit Malfunction (Low Input)	<Ref. to GD(H4SO)-254, DTC P1514 — ISC SOLENOID VALVE SIGNAL #3 CIRCUIT MALFUNCTION (LOW INPUT) —, Diagnostic Trouble Code (DTC) Detecting Criteria.>
P1515	ISC Solenoid Valve Signal #3 Circuit Malfunction (High Input)	<Ref. to GD(H4SO)-256, DTC P1515 — ISC SOLENOID VALVE SIGNAL #3 CIRCUIT MALFUNCTION (HIGH INPUT) —, Diagnostic Trouble Code (DTC) Detecting Criteria.>
P1516	ISC Solenoid Valve Signal #4 Circuit Malfunction (Low Input)	<Ref. to GD(H4SO)-258, DTC P1516 — ISC SOLENOID VALVE SIGNAL #4 CIRCUIT MALFUNCTION (LOW INPUT) —, Diagnostic Trouble Code (DTC) Detecting Criteria.>
P1517	ISC Solenoid Valve Signal #4 Circuit Malfunction (High Input)	<Ref. to GD(H4SO)-260, DTC P1517 — ISC SOLENOID VALVE SIGNAL #4 CIRCUIT MALFUNCTION (HIGH INPUT) —, Diagnostic Trouble Code (DTC) Detecting Criteria.>
P1518	Starter Switch Circuit Low Input	<Ref. to GD(H4SO)-262, DTC P1518 — STARTER SWITCH CIRCUIT LOW INPUT —, Diagnostic Trouble Code (DTC) Detecting Criteria.>

# LIST OF DIAGNOSTIC TROUBLE CODE (DTC)

## GENERAL DESCRIPTION

DTC	Item	Index
P1560	Back-Up Voltage Circuit Malfunction	<Ref. to GD(H4SO)-263, DTC P1560 — BACK-UP VOLTAGE CIRCUIT MALFUNCTION —, Diagnostic Trouble Code (DTC) Detecting Criteria.>
P1698	Engine Torque Control Cut Signal Circuit Malfunction (Low Input)	<Ref. to GD(H4SO)-264, DTC P1698 — ENGINE TORQUE CONTROL CUT SIGNAL CIRCUIT MALFUNCTION (LOW INPUT) —, Diagnostic Trouble Code (DTC) Detecting Criteria.>
P1699	Engine Torque Control Cut Signal Circuit Malfunction (High Input)	<Ref. to GD(H4SO)-265, DTC P1699 — ENGINE TORQUE CONTROL CUT SIGNAL CIRCUIT MALFUNCTION (HIGH INPUT) —, Diagnostic Trouble Code (DTC) Detecting Criteria.>
P1700	Throttle Position Sensor Circuit Malfunction For AT	<Ref. to GD(H4SO)-266, DTC P1700 — THROTTLE POSITION SENSOR CIRCUIT MALFUNCTION FOR AT —, Diagnostic Trouble Code (DTC) Detecting Criteria.>
P1711	Engine Torque Control Signal #1 Circuit Malfunction	<Ref. to GD(H4SO)-268, DTC P1711 — ENGINE TORQUE CONTROL SIGNAL #1 CIRCUIT MALFUNCTION —, Diagnostic Trouble Code (DTC) Detecting Criteria.>
P1712	Engine Torque Control Signal #2 Circuit Malfunction	<Ref. to GD(H4SO)-269, DTC P1712 — ENGINE TORQUE CONTROL SIGNAL #2 CIRCUIT MALFUNCTION —, Diagnostic Trouble Code (DTC) Detecting Criteria.>
P2096	Post Catalyst Fuel Trim System Too Lean Bank 1	<Ref. to GD(H4SO)-270, DTC P2096 — POST CATALYST FUEL TRIM SYSTEM TOO LEAN BANK 1 —, Diagnostic Trouble Code (DTC) Detecting Criteria.>
P2097	Post Catalyst Fuel Trim System Too Rich Bank 1	<Ref. to GD(H4SO)-272, DTC P2097 — POST CATALYST FUEL TRIM SYSTEM TOO RICH BANK 1 —, Diagnostic Trouble Code (DTC) Detecting Criteria.>



# LIST OF DIAGNOSTIC TROUBLE CODE (DTC)

GENERAL DESCRIPTION

---

MEMO:

# DIAGNOSTIC TROUBLE CODE (DTC) DETECTING CRITERIA

## GENERAL DESCRIPTION

## 2. Diagnostic Trouble Code (DTC) Detecting Criteria

### A: DTC P0030 — HO2S HEATER CONTROL CIRCUIT (BANK 1 SENSOR 1) —

#### 1. OUTLINE OF DIAGNOSIS

Detect the malfunction of front oxygen (A/F) sensor heater.

Diagnosis is performed using A/F microcomputer, and communication is established between A/F microcomputer and main microcomputer. Judge NG when the data of heater malfunction NG is transmitted.

Judge NG when the front oxygen (A/F) sensor element impedance is out of the standard value.

#### 2. COMPONENT DESCRIPTION

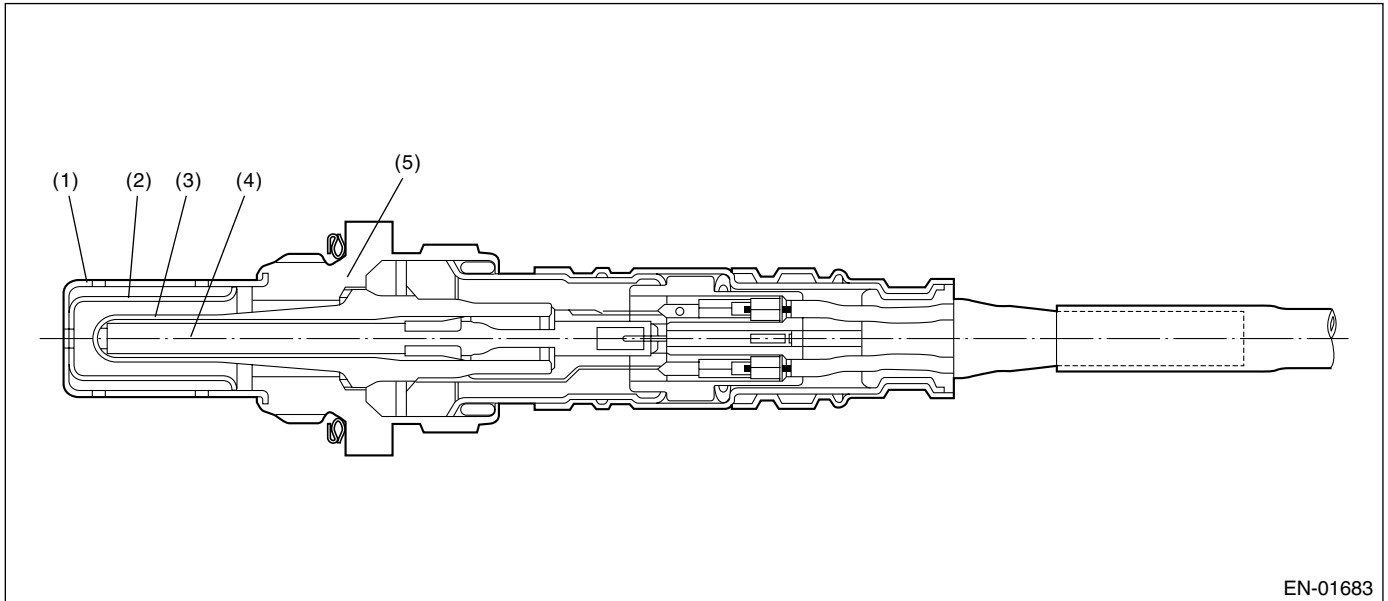

(1) Element cover (outer)

(2) Element cover (inner)

(3) Sensor element

(4) Ceramic heater

(5) Sensor housing

#### 3. ENABLE CONDITIONS

Secondary Parameters	Enable Conditions
Battery voltage	> 10.9 V
After heater control starting	More than 30 seconds
After fuel shut-off	More than 20 seconds

#### 4. GENERAL DRIVING CYCLE

Perform the diagnosis continuously in 30 seconds after the heater continuity starting, and complete the diagnosis if making a NG judgment.

# DIAGNOSTIC TROUBLE CODE (DTC) DETECTING CRITERIA

GENERAL DESCRIPTION

## 5. DIAGNOSTIC METHOD

### • Abnormality Judgment

Judge NG when one of the malfunction criteria below is completed.

### • Judgment Value

Malfunction Criteria	Threshold Value
Impedance of front oxygen (A/F) sensor	< 10 $\Omega$ or > 40 $\Omega$

**Time Needed for Diagnosis:** 10 seconds

**Malfunction Indicator Light Illumination:** Illuminates when malfunction occurs in 2 continuous driving cycles.

### • Normality Judgment

Judge OK when all of the malfunction criteria below is completed.

### • Judgment Value

Malfunction Criteria	Threshold Value
Impedance of front oxygen (A/F) sensor	10 $\Omega$ — 40 $\Omega$

## 6. DTC CLEAR CONDITION

- When the OK idling cycle was completed 40 times in a row
- When "Clear Memory" was performed

## 7. MALFUNCTION INDICATOR LIGHT CLEAR CONDITION

- When the OK driving cycle was completed 3 times in a row
- When "Clear Memory" was performed

## 8. FAIL SAFE

None

## 9. ECM OPERATION AT DTC SETTING

Memorize the freeze frame data. (For test mode \$02)

# DIAGNOSTIC TROUBLE CODE (DTC) DETECTING CRITERIA

## GENERAL DESCRIPTION

### B: DTC P0031 — HO<sub>2</sub>S HEATER CONTROL CIRCUIT LOW (BANK 1 SENSOR 1)

#### 1. OUTLINE OF DIAGNOSIS

Detect the open or short circuit of front oxygen (A/F) sensor heater.

Diagnosis is performed using A/F microcomputer, and communication is established between A/F microcomputer and main microcomputer. Judge NG when the data of open circuit and shortage NG is transmitted.

#### 2. COMPONENT DESCRIPTION

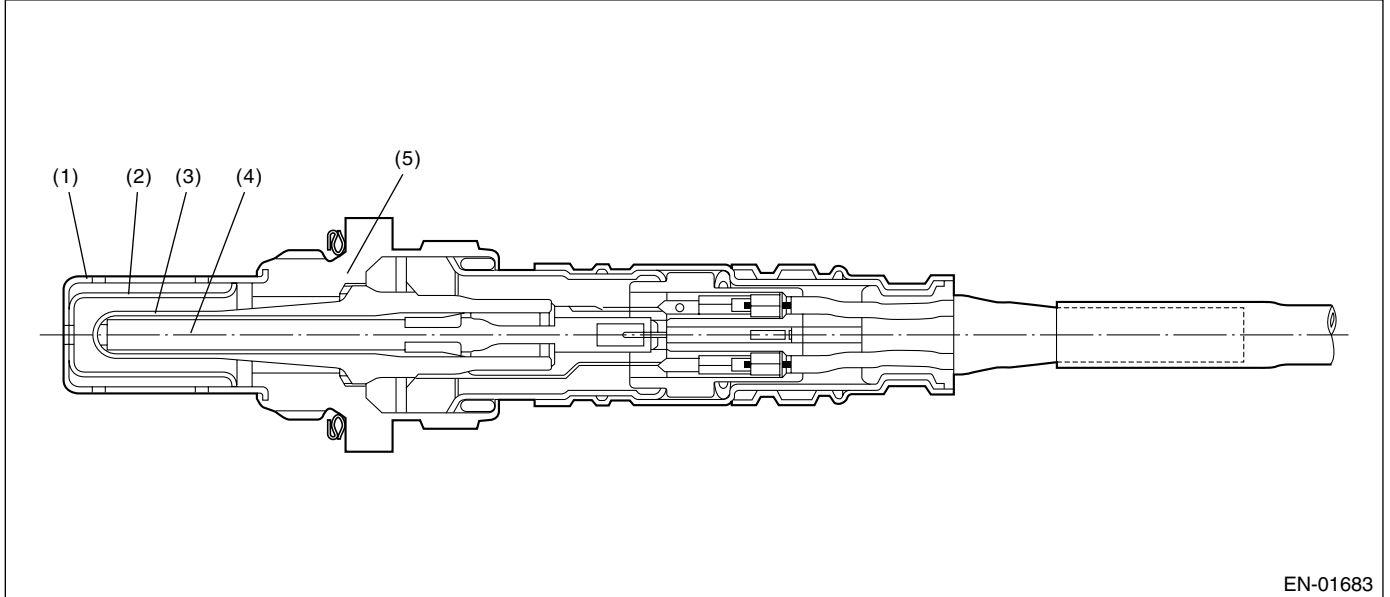

- |                           |                    |                    |
|---------------------------|--------------------|--------------------|
| (1) Element cover (outer) | (3) Sensor element | (5) Sensor housing |
| (2) Element cover (inner) | (4) Ceramic heater |                    |

#### 3. ENABLE CONDITION

Secondary Parameters	Enable Conditions
Battery voltage	10.9 V or more
Heater control	In operation

#### 4. GENERAL DRIVING CYCLE

Terminate the diagnosis if the open or short circuit becomes NG once by performing diagnosis continuously.

#### 5. DIAGNOSTIC METHOD

Judge NG when the continuous time of completing all the malfunction criteria below becomes more than 4.5 seconds.

##### Judgment Value

Malfunction Criteria	Threshold Value
Heater circuit	ON
Heater both edge voltage	< 5 V
Heater current	< 1.5 A

**Time Needed for Diagnosis:** 10 seconds

**Malfunction Indicator Light Illumination:** Illuminates as soon as malfunction occurs.

#### 6. DTC CLEAR CONDITION

- When the OK idling cycle was completed 40 times in a row
- When "Clear Memory" was performed

# DIAGNOSTIC TROUBLE CODE (DTC) DETECTING CRITERIA

GENERAL DESCRIPTION

---

## 7. MALFUNCTION INDICATOR LIGHT CLEAR CONDITION

- When the OK driving cycle was completed 3 times in a row
- When "Clear Memory" was performed

## 8. FAIL SAFE

None

## 9. ECM OPERATION AT DTC SETTING

Memorize the freeze frame data. (For test mode \$02)

# DIAGNOSTIC TROUBLE CODE (DTC) DETECTING CRITERIA

## GENERAL DESCRIPTION

### C: DTC P0032 — HO2S HEATER CONTROL CIRCUIT HIGH (BANK 1 SENSOR 1) —

#### 1. OUTLINE OF DIAGNOSIS

Detect the open or short circuit of front oxygen (A/F) sensor heater.

Diagnosis is performed using A/F microcomputer, and communication is established between A/F microcomputer and main microcomputer. Judge NG when the data of open circuit and shortage NG is transmitted.

#### 2. COMPONENT DESCRIPTION

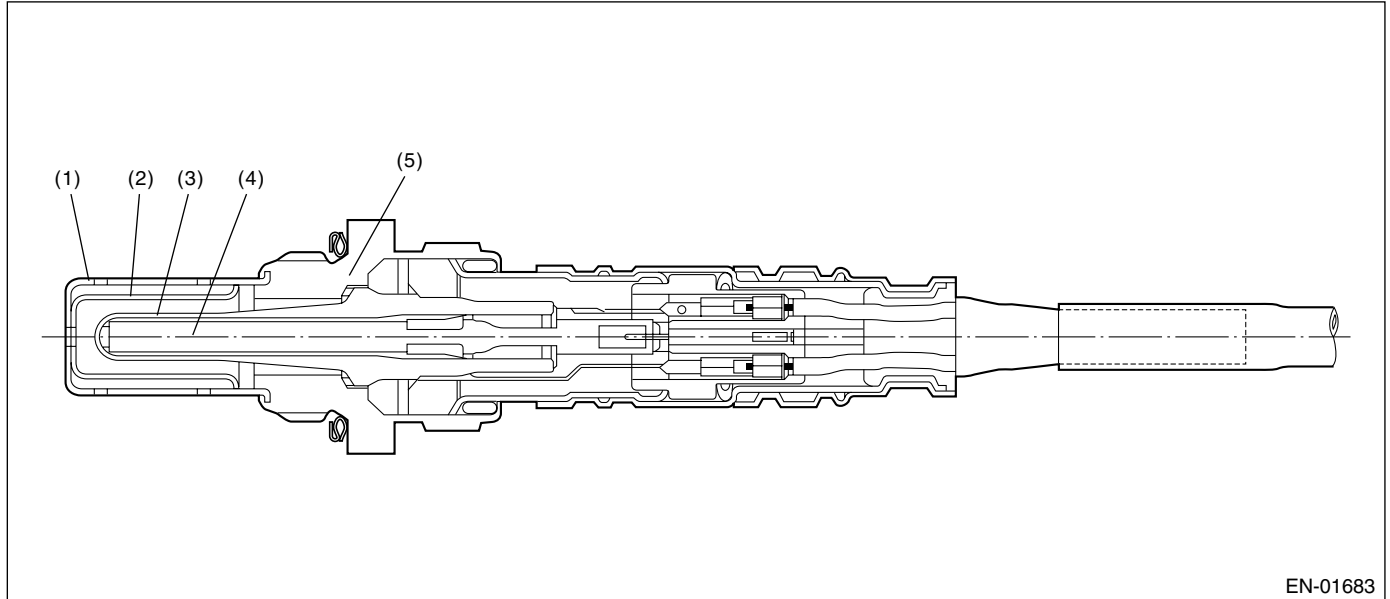

- |                           |                    |                    |
|---------------------------|--------------------|--------------------|
| (1) Element cover (outer) | (3) Sensor element | (5) Sensor housing |
| (2) Element cover (inner) | (4) Ceramic heater |                    |

#### 3. ENABLE CONDITION

Secondary Parameters	Enable Conditions
Battery voltage	10.9 V or more
Heater control	In operation

#### 4. GENERAL DRIVING CYCLE

Terminate the diagnosis if the open or short circuit becomes NG once by performing diagnosis continuously.

#### 5. DIAGNOSTIC METHOD

Judge NG when one of the malfunction criteria below are completed.

##### Judgment Value

Malfunction Criteria	Threshold Value
Heater circuit	ON
Heater both edge voltage	< 5 V
Heater current	< 1.5 A
Heater current	≥ 23 A

**Time Needed for Diagnosis:** 4.5 seconds

**Malfunction Indicator Light Illumination:** Illuminates as soon as malfunction occurs.

#### 6. DTC CLEAR CONDITION

- When the OK idling cycle was completed 40 times in a row
- When "Clear Memory" was performed

# DIAGNOSTIC TROUBLE CODE (DTC) DETECTING CRITERIA

GENERAL DESCRIPTION

---

## 7. MALFUNCTION INDICATOR LIGHT CLEAR CONDITION

- When the OK driving cycle was completed 3 times in a row
- When "Clear Memory" was performed

## 8. FAIL SAFE

None

## 9. ECM OPERATION AT DTC SETTING

Memorize the freeze frame data. (For test mode \$02)

# DIAGNOSTIC TROUBLE CODE (DTC) DETECTING CRITERIA

## GENERAL DESCRIPTION

### D: DTC P0037 — HO<sub>2</sub>S HEATER CONTROL CIRCUIT LOW (BANK 1 SENSOR 2)

#### 1. OUTLINE OF DIAGNOSIS

Detect the open or short circuit of rear oxygen sensor heater.  
Judge NG when out of the standard value.

#### 2. COMPONENT DESCRIPTION

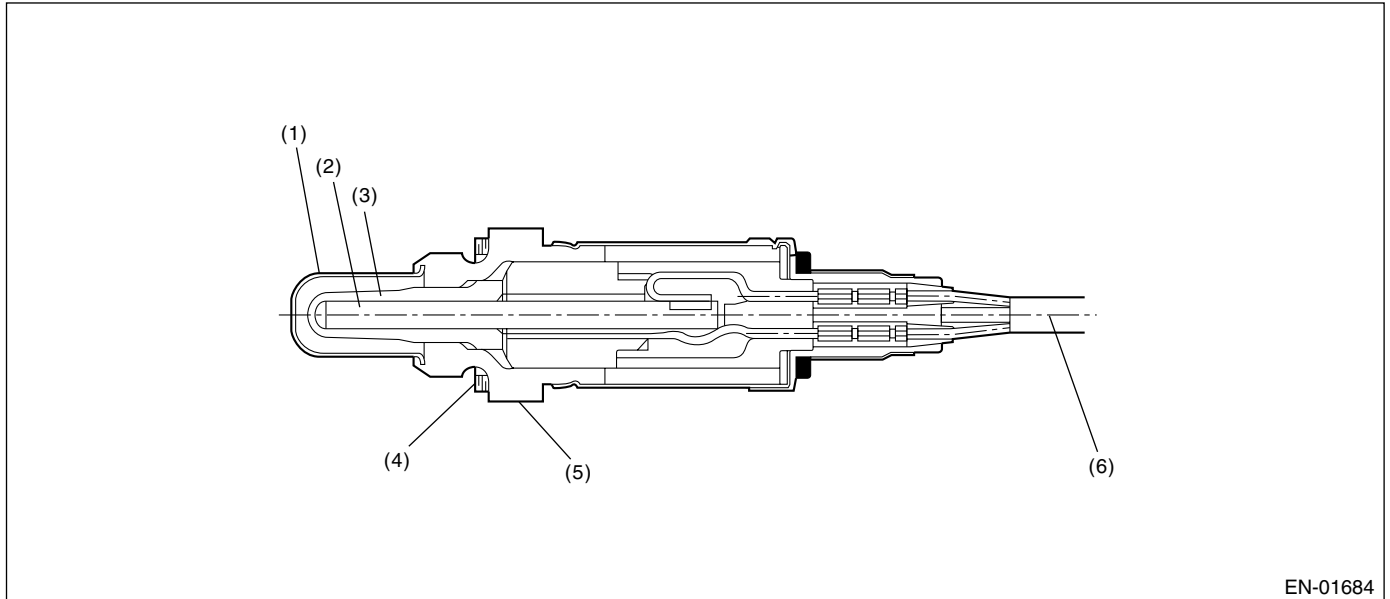

EN-01684

(1) Protection tube  
(2) Ceramic heater

(3) Zirconium tube  
(4) Gasket

(5) Sensor housing  
(6) Harness

#### 3. ENABLE CONDITION

Secondary Parameters	Enable Conditions
Ignition switch	ON
Engine speed	$\geq 500$ rpm
After engine starting	10 seconds or more
Battery voltage	$\geq 8$ V

#### 4. GENERAL DRIVING CYCLE

In 10 seconds after starting the engine, perform the diagnosis just once.

#### 5. DIAGNOSTIC METHOD

Judge NG when the continuous time until completing the malfunction criteria below becomes 10 seconds or more. Judge OK when the continuous time until completing none of the malfunction criteria below becomes 10 seconds or more.

##### Judgment Value

Malfunction Criteria	Threshold Value
Calculated electric power	$< 6$ W

**Time needed for diagnosis:** 10 seconds

**Malfunction Indicator Light Illumination:** Illuminates when malfunction occurs in 2 continuous driving cycles.



# DIAGNOSTIC TROUBLE CODE (DTC) DETECTING CRITERIA

GENERAL DESCRIPTION

---

## 6. DTC CLEAR CONDITION

- When the OK idling cycle was completed 40 times in a row
- When "Clear Memory" was performed

## 7. MALFUNCTION INDICATOR LIGHT CLEAR CONDITION

- When the OK driving cycle was completed 3 times in a row
- When "Clear Memory" was performed

## 8. FAIL SAFE

None

## 9. ECM OPERATION AT DTC SETTING

- Memorize the freeze frame data. (For test mode \$02)
- Memorize the diagnostic value and trouble standard value. (For test mode \$06)

# DIAGNOSTIC TROUBLE CODE (DTC) DETECTING CRITERIA

## GENERAL DESCRIPTION

### E: DTC P0038 — HO2S HEATER CONTROL CIRCUIT HIGH (BANK 1 SENSOR 2) —

#### 1. OUTLINE OF DIAGNOSIS

Detect the open or short circuit of rear oxygen sensor heater.  
Judge NG when out of the standard value.

#### 2. COMPONENT DESCRIPTION

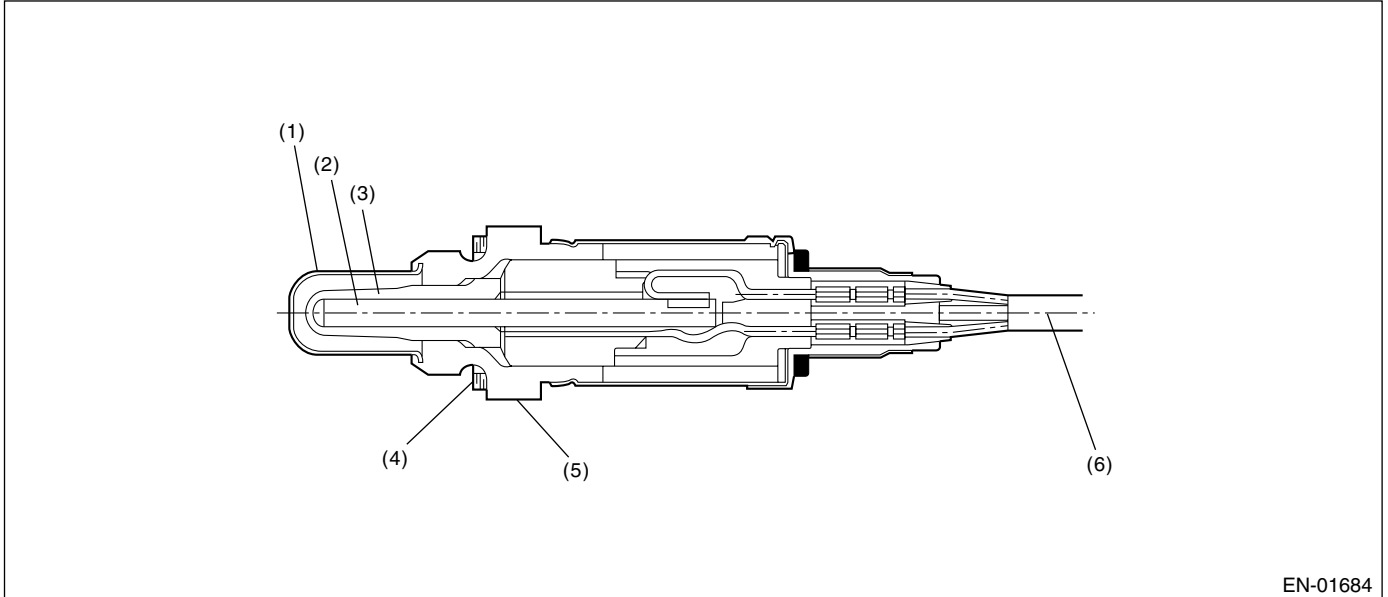

EN-01684

(1) Protection tube  
(2) Ceramic heater

(3) Zirconium tube  
(4) Gasket

(5) Sensor housing  
(6) Harness

#### 3. ENABLE CONDITION

Secondary Parameters	Enable Conditions
Ignition switch	ON
Engine speed	$\geq 500$ rpm
After engine starting	10 seconds or more
Battery voltage	$\geq 8$ V

#### 4. GENERAL DRIVING CYCLE

In 10 seconds after starting the engine, perform the diagnosis just once.

#### 5. DIAGNOSTIC METHOD

Judge NG when the continuous time until completing the malfunction criteria below becomes 10 seconds or more. Judge OK when the continuous time until completing none of the malfunction criteria below becomes 10 seconds or more.

##### Judgment Value

Malfunction Criteria	Threshold Value
Calculated electric power	$\geq 50$ W

**Time needed for diagnosis:** 10 seconds

**Malfunction Indicator Light Illumination:** Illuminates when malfunction occurs in 2 continuous driving cycles.

# DIAGNOSTIC TROUBLE CODE (DTC) DETECTING CRITERIA

GENERAL DESCRIPTION

---

## 6. DTC CLEAR CONDITION

- When the OK idling cycle was completed 40 times in a row
- When "Clear Memory" was performed

## 7. MALFUNCTION INDICATOR LIGHT CLEAR CONDITION

- When the OK driving cycle was completed 3 times in a row
- When "Clear Memory" was performed

## 8. FAIL SAFE

None

## 9. ECM OPERATION AT DTC SETTING

- Memorize the freeze frame data. (For test mode \$02)
- Memorize the diagnostic value and trouble standard value. (For test mode \$06)

# DIAGNOSTIC TROUBLE CODE (DTC) DETECTING CRITERIA

## GENERAL DESCRIPTION

### F: DTC P0065 — AIR ASSISTED INJECTOR CONTROL RANGE/PERFORMANCE —

#### 1. OUTLINE OF DIAGNOSIS

Detect the malfunction of AAI solenoid valve.

Intake manifold pressure (negative pressure) is constant because the throttle valve is fully closed during fuel cut at deceleration. At this time, opening AAI solenoid valve makes the intake manifold pressure larger. For AAI solenoid valve function diagnosis, judge OK or NG by the amount of change of intake manifold pressure when opening and closing the AAI solenoid valve.

**Max. value with the valve open - Min. value with the valve closed < Threshold value → NG**

**Max. value with the valve open - Min. value with the valve closed ≥ Threshold value → OK**

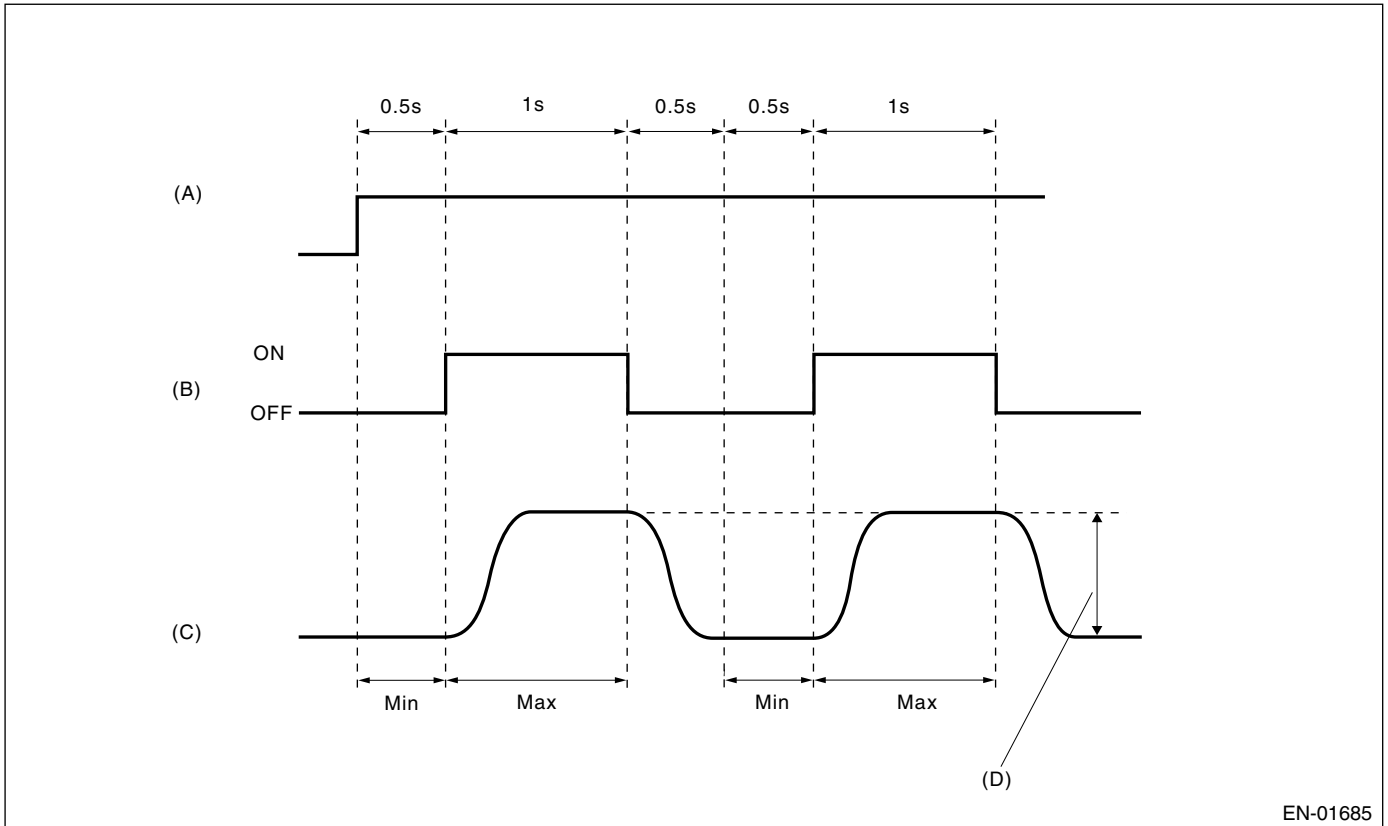

EN-01685

(A) Conditions executed for diagnosis

(C) Intake manifold pressure (At normal condition)

(D) Diagnostic value

(B) AAI solenoid valve

# DIAGNOSTIC TROUBLE CODE (DTC) DETECTING CRITERIA

GENERAL DESCRIPTION

## 2. COMPONENT DESCRIPTION

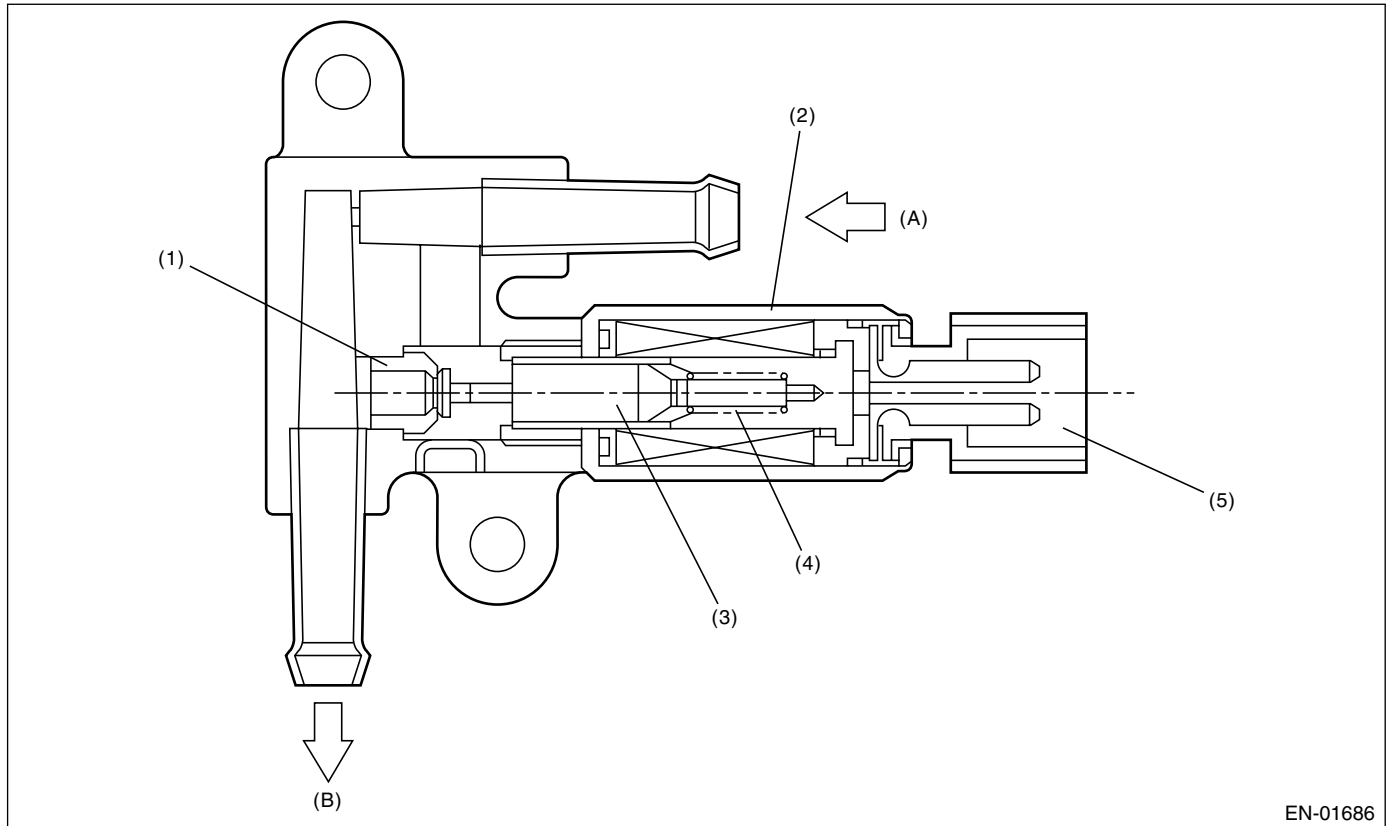

EN-01686

- (1) Valve seat
- (2) Solenoid
- (3) Plunger and valve

- (4) Spring
- (5) Connector

- (A) From idle air control solenoid valve
- (B) To injector

## 3. ENABLE CONDITION

Secondary Parameters	Enable Conditions
Engine coolant temperature	$\geq 75^{\circ}\text{C}$ ( $167^{\circ}\text{F}$ )
Engine speed	1300 $\leftrightarrow$ 2300 rpm
Vehicle speed	$\geq 60$ km/h (37 MPH)
Atmospheric pressure	$\geq 86$ kPa (642 mmHg, 25 inHg)
Atmospheric-MAP	$\geq 53$ kPa (400 mmHg, 16 inHg)
Fuel cut event by coasting	In operation
AAI solenoid valve position	OFF (closed)

## 4. GENERAL DRIVING CYCLE

Conduct a serial diagnosis during fuel cut at deceleration from approx. 100 km/h (62 MPH). Be careful for vehicle speed and engine speed. (Diagnosis may not finish if the vehicle speed and engine speed conditions become out of specification.)

# DIAGNOSTIC TROUBLE CODE (DTC) DETECTING CRITERIA

## GENERAL DESCRIPTION

---

### 5. DIAGNOSTIC METHOD

Judge NG when the malfunction criteria below are completed 2 times in a row. Judge OK and clear the NG if not completed once

#### Judgment Value

Malfunction Criteria	Threshold Value
Paai1 – Paai2	
Paai1; max. MAP value during AAI solenoid valve ON signal	0.7 kPa (5 mmHg, 0.2 inHg) [101 kPa (760 mmHg, 30 inHg) in atmospheric pressure]
Paai2; min. MAP value during 0.5 seconds just before changing the valve from OFF to ON	0.05 kPa (0.4mm, 0.016 inHg) [86 kPa (642 mmHg, 25 inHg) in atmospheric pressure]

**Time needed for diagnosis:** 9 seconds

**Malfunction Indicator Light Illumination:** Illuminates when malfunction occurs in 2 continuous driving cycles.

### 6. DTC CLEAR CONDITION

- When the OK idling cycle is completed 40 times in a row
- When “Clear Memory” was performed

### 7. MALFUNCTION INDICATOR LIGHT CLEAR CONDITION

- When the OK driving cycle is completed 3 times in a row
- When “Clear Memory” was performed

### 8. FAIL SAFE

None

### 9. ECM OPERATION AT DTC SETTING

Memorize the freeze frame data. (For test mode \$02)

# DIAGNOSTIC TROUBLE CODE (DTC) DETECTING CRITERIA

GENERAL DESCRIPTION

---

MEMO:

# DIAGNOSTIC TROUBLE CODE (DTC) DETECTING CRITERIA

## GENERAL DESCRIPTION

### G: DTC P0066 — AIR ASSISTED INJECTOR CONTROL CIRCUIT OR CIRCUIT LOW —

#### 1. OUTLINE OF DIAGNOSIS

Detect the open or short circuit of AAI solenoid valve. Judge NG when the ECM output level is different from actual terminal level.

#### 2. COMPONENT DESCRIPTION

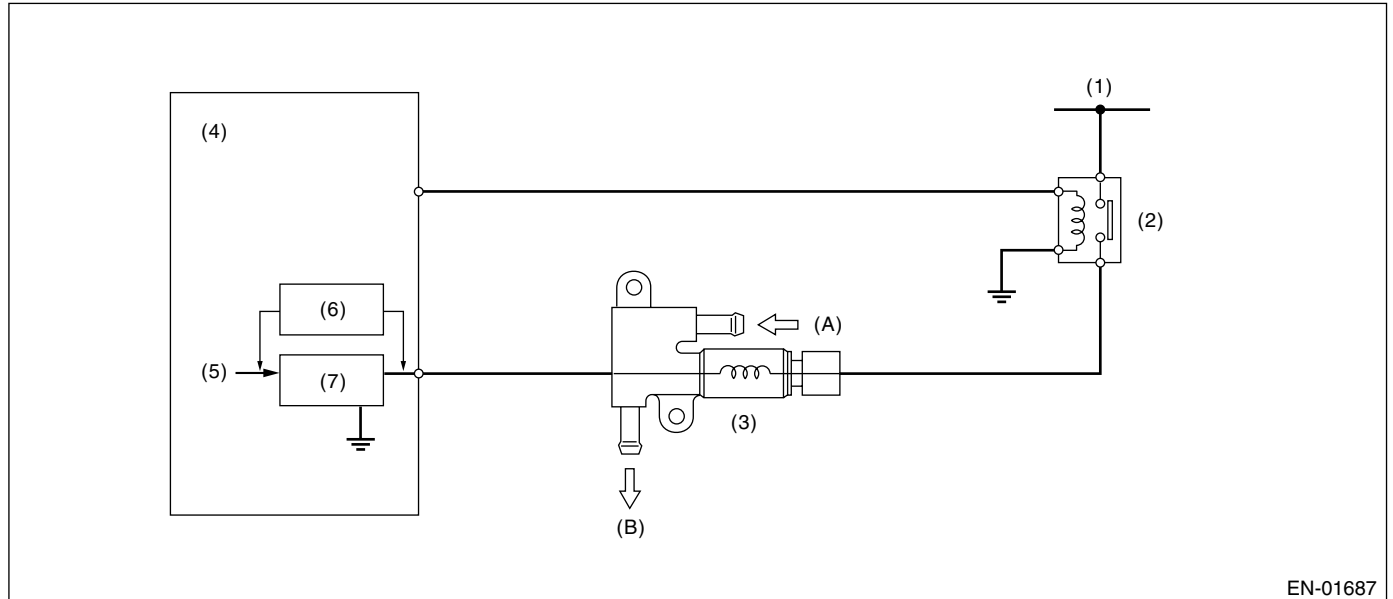

EN-01687

- |                                 |                       |  |
|---------------------------------|-----------------------|--|
| (1) Battery                     | (5) CPU               | (A) From idle air control solenoid valve |
| (2) Main relay                  | (6) Detecting circuit | (B) To injector                          |
| (3) AAI solenoid valve          | (7) Switching circuit |  |
| (4) Engine control module (ECM) |                       |  |

#### 3. ENABLE CONDITION

Secondary Parameters	Enable Conditions
Engine speed	$\geq 500$ rpm
Battery voltage	$\geq 10.9$ V
After engine starting	2 seconds or more
Ignition switch	ON

#### 4. GENERAL DRIVING CYCLE

Perform the diagnosis continuously in 2 seconds after starting the engine.



# DIAGNOSTIC TROUBLE CODE (DTC) DETECTING CRITERIA

GENERAL DESCRIPTION

## 5. DIAGNOSTIC METHOD

### • Abnormality Judgment

Judge NG when the cumulative time until completing the malfunction criteria below becomes more than the time needed for diagnosis (2.5 seconds).

### • Judgment Value

Malfunction Criteria	Threshold Value
Terminal voltage level while ECM sent OFF signal	Low level

**Time Needed for Diagnosis:** 2.5 seconds

**Malfunction Indicator Light Illumination:** Illuminates when malfunction occurs in 2 continuous driving cycles.

### • Normality Judgment

Judge OK and clear the NG when the malfunction criteria below are completed.

### • Judgment Value

Malfunction Criteria	Threshold Value
Terminal voltage level while ECM sent OFF signal	High level

## 6. DTC CLEAR CONDITION

- When the OK idling cycle is completed 40 times in a row
- When "Clear Memory" was performed

## 7. MALFUNCTION INDICATOR LIGHT CLEAR CONDITION

- When the OK driving cycle is completed 3 times in a row
- When "Clear Memory" was performed

## 8. FAIL SAFE

None

## 9. ECM OPERATION AT DTC SETTING

Memorize the freeze frame data. (For test mode \$02)

# DIAGNOSTIC TROUBLE CODE (DTC) DETECTING CRITERIA

## GENERAL DESCRIPTION

### H: DTC P0067 — AIR ASSISTED INJECTOR CONTROL CIRCUIT HIGH —

#### 1. OUTLINE OF DIAGNOSIS

Detect the open or short circuit of AAI solenoid valve. Judge NG when the ECM output level is different from actual terminal level.

#### 2. COMPONENT DESCRIPTION

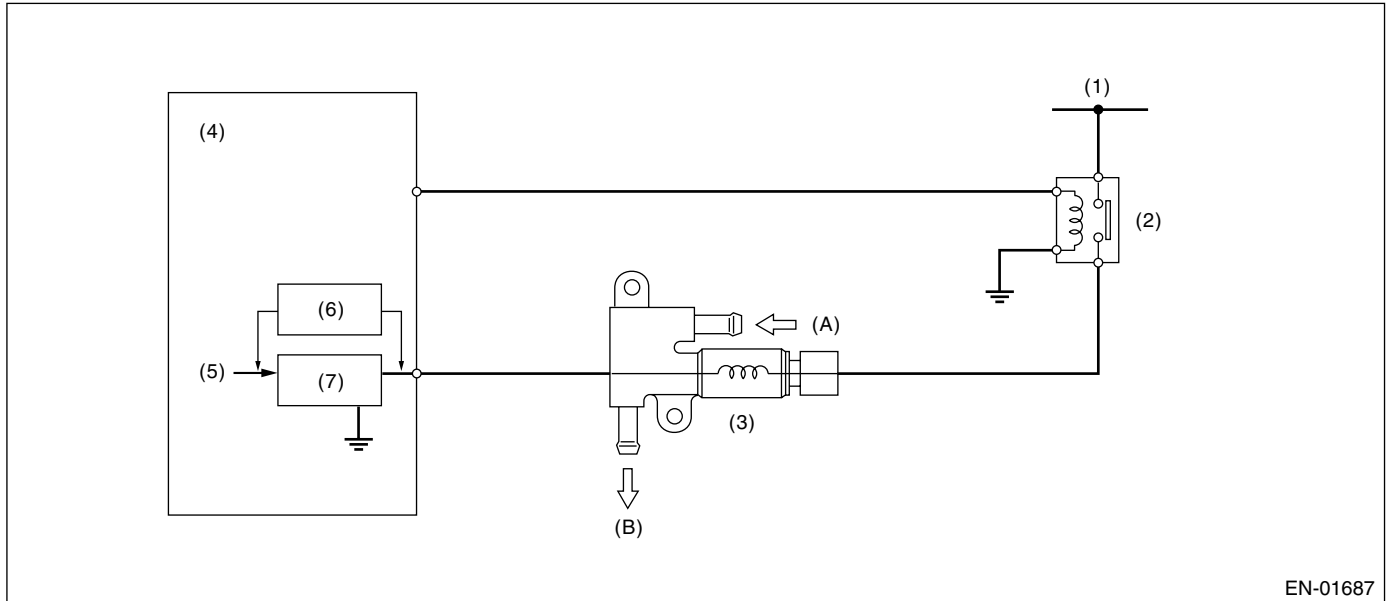

- (1) Battery
- (2) Main relay
- (3) AAI solenoid valve
- (4) Engine control module (ECM)
- (5) CPU
- (6) Detecting circuit
- (7) Switching circuit
- (A) From idle air control solenoid valve
- (B) To injector

#### 3. ENABLE CONDITION

Secondary Parameters	Enable Conditions
Engine speed	≥ 500 rpm
Battery voltage	≥ 10.9 V
After engine starting	2 seconds or more
Ignition switch	ON

#### 4. GENERAL DRIVING CYCLE

Perform the diagnosis continuously in 2 seconds after starting the engine.

# DIAGNOSTIC TROUBLE CODE (DTC) DETECTING CRITERIA

GENERAL DESCRIPTION

## 5. DIAGNOSTIC METHOD

### • Abnormality Judgment

Judge NG when the cumulative time until completing the malfunction criteria below becomes more than the time needed for diagnosis.

### • Judgment Value

Malfunction Criteria	Threshold Value
Terminal voltage level while ECM sent OFF signal	High level

**Time Needed for Diagnosis:** 2.5 seconds

**Malfunction Indicator Light Illumination:** Illuminates when malfunction occurs in 2 continuous driving cycles.

### • Normality Judgment

Judge OK and clear the NG when the malfunction criteria below are completed.

### • Judgment Value

Malfunction Criteria	Threshold Value
Terminal voltage level while ECM sent OFF signal	Low level

## 6. DTC CLEAR CONDITION

- When the OK idling cycle is completed 40 times in a row
- When "Clear Memory" was performed

## 7. MALFUNCTION INDICATOR LIGHT CLEAR CONDITION

- When the OK driving cycle is completed 3 times in a row
- When "Clear Memory" was performed

## 8. FAIL SAFE

None

## 9. ECM OPERATION AT DTC SETTING

Memorize the freeze frame data. (For test mode \$02)

# DIAGNOSTIC TROUBLE CODE (DTC) DETECTING CRITERIA

## GENERAL DESCRIPTION

### I: DTC P0068 — MANIFOLD PRESSURE SENSOR RANGE/PERFORMANCE —

#### 1. OUTLINE OF DIAGNOSIS

Detect the malfunction of intake manifold pressure sensor output property.

Judge NG when the intake manifold pressure is small (voltage is low) regardless of the driving situation that the intake manifold pressure may be thought larger than engine speed and throttle opening. (Low side)

On the other hand, judge NG when the intake manifold pressure is large (voltage is high) regardless of the driving situation that the intake manifold pressure may be thought smaller than engine speed and throttle opening. (High side)

#### 2. COMPONENT DESCRIPTION

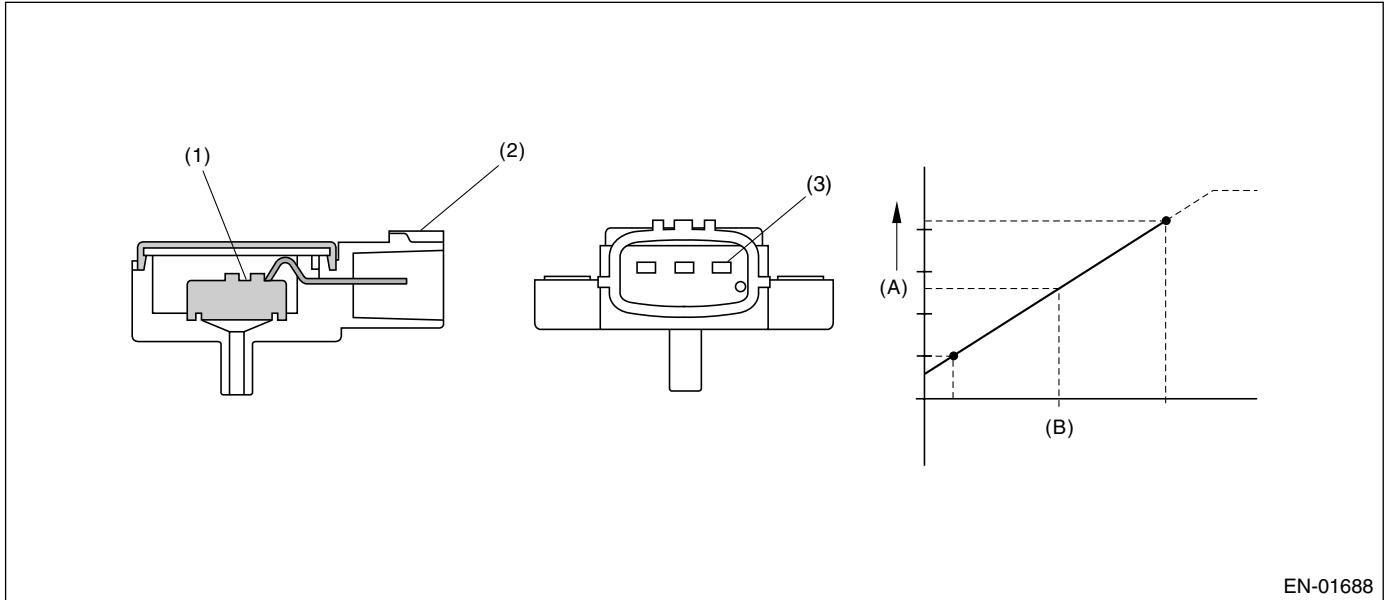

EN-01688

(1) Pressure detecting part  
(2) Connector

(3) Terminal

(A) Output voltage  
(B) Input voltage

#### 3. ENABLE CONDITION

Secondary Parameters	Enable Conditions
Engine coolant temperature	$\geq 75^{\circ}\text{C}$ ( $167^{\circ}\text{F}$ )

#### 4. GENERAL DRIVING CYCLE

Perform the diagnosis continuously after idling.

#### 5. DIAGNOSTIC METHOD

##### • Abnormality Judgment

Judge NG when the continuous time of completing all the malfunction criteria of Low side or High side below becomes more than the time (3 seconds) needed for diagnosis.

# DIAGNOSTIC TROUBLE CODE (DTC) DETECTING CRITERIA

GENERAL DESCRIPTION

## • Judgment Value

Malfunction Criteria	Threshold Value
(Low side)	
Engine speed	> 2500 rpm
Throttle position	> 15°
Output voltage	≤ 0.985 V
(High side)	
Engine speed	600 ←→ 900 rpm
Throttle position	≤ 2°
Output voltage	> 2.81 V

**Time Needed for Diagnosis:** 3 seconds

**Malfunction Indicator Light Illumination:** Illuminates when malfunction occurs in 2 continuous driving cycles.

## • Normality Judgment

Judge OK and clear the NG when all the malfunction criteria of Low side or High side are completed.

## • Judgment Value

Malfunction Criteria	Threshold Value
(Low side)	
Engine speed	> 2500 rpm
Throttle position	> 15°
Output voltage	> 0.985 V
(High side)	
Engine speed	600 ←→ 900 rpm
Throttle position	≤ 2°
Output voltage	≤ 2.81 V

## 6. DTC CLEAR CONDITION

- When the OK idling cycle is completed 40 times in a row
- When "Clear Memory" was performed

## 7. MALFUNCTION INDICATOR LIGHT CLEAR CONDITION

- When the OK driving cycle is completed 3 times in a row
- When "Clear Memory" was performed

## 8. FAIL SAFE

None

## 9. ECM OPERATION AT DTC SETTING

Memorize the freeze frame data. (For test mode \$02)

# DIAGNOSTIC TROUBLE CODE (DTC) DETECTING CRITERIA

## GENERAL DESCRIPTION

### J: DTC P0107 — MANIFOLD ABSOLUTE PRESSURE/BAROMETRIC PRESSURE CIRCUIT LOW INPUT —

#### 1. OUTLINE OF DIAGNOSIS

Detect the open or short circuit of intake manifold pressure sensor.  
Judge NG when out of the standard value.

#### 2. COMPONENT DESCRIPTION

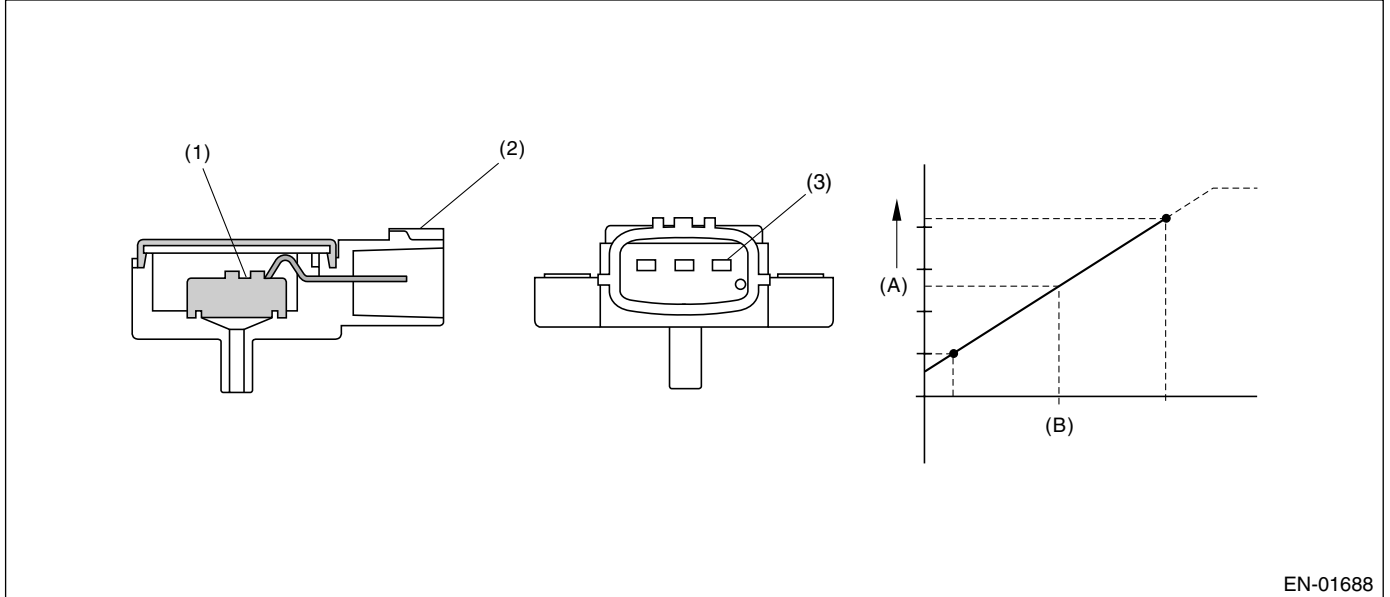

EN-01688

(1) Pressure detecting part  
(2) Connector

(3) Terminal

(A) Output voltage  
(B) Input voltage

#### 3. ENABLE CONDITION

Secondary Parameters	Enable Conditions
None	

#### 4. GENERAL DRIVING CYCLE

Always perform the diagnosis continuously.

#### 5. DIAGNOSTIC METHOD

Judge NG when the continuous time until completing the malfunction criteria below becomes more than the time (2.5 seconds) needed for diagnosis. Judge fail safe NG when the continuous time until completing the malfunction criteria below becomes more than time (0.1 seconds) needed for diagnosis. Judge OK and clear the NG when the malfunction criteria below are not completed.

##### Judgment Value

Malfunction Criteria	Threshold Value
Output voltage	$\leq 0.14$ V

**Time Needed for Diagnosis:** 2.5 seconds

**Malfunction Indicator Light Illumination:** Illuminates as soon as malfunction occurs.

#### 6. DTC CLEAR CONDITION

- When the OK idling cycle is completed 40 times in a row
- When "Clear Memory" was performed

# DIAGNOSTIC TROUBLE CODE (DTC) DETECTING CRITERIA

GENERAL DESCRIPTION

---

## 7. MALFUNCTION INDICATOR LIGHTCLEAR CONDITION

- When the OK driving cycle is completed 3 times in a row
- When "Clear Memory" was performed

## 8. FAIL SAFE

Calculate the manifold absolute pressure using the map figured by engine speed and throttle opening grid.

## 9. ECM OPERATION AT DTC SETTING

Memorize the freeze frame data. (For test mode \$02)

# DIAGNOSTIC TROUBLE CODE (DTC) DETECTING CRITERIA

## GENERAL DESCRIPTION

### K: DTC P0108 — MANIFOLD ABSOLUTE PRESSURE/BAROMETRIC PRESSURE CIRCUIT HIGH INPUT —

#### 1. OUTLINE OF DIAGNOSIS

Detect the open or short circuit of intake manifold pressure sensor.  
Judge NG when out of the standard value.

#### 2. COMPONENT DESCRIPTION

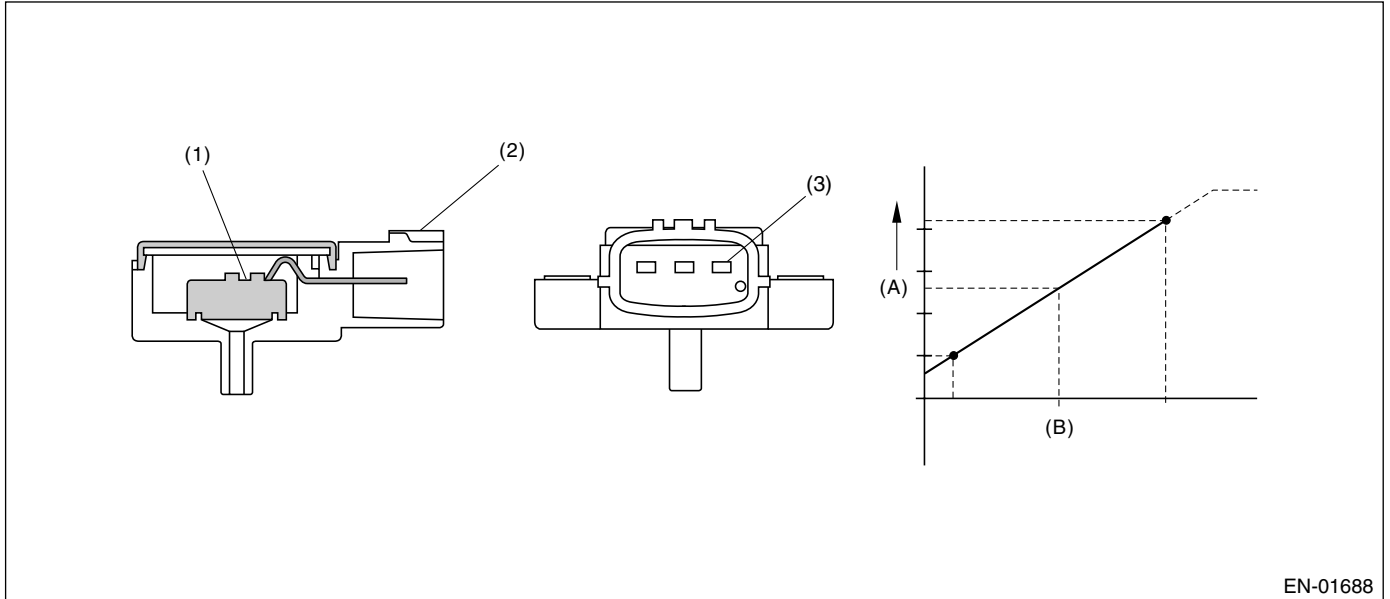

EN-01688

(1) Pressure detecting part  
(2) Connector

(3) Terminal

(A) Output voltage  
(B) Input voltage

#### 3. ENABLE CONDITION

Secondary Parameters	Enable Conditions
None	

#### 4. GENERAL DRIVING CYCLE

Always perform the diagnosis continuously.

#### 5. DIAGNOSTIC METHOD

Judge NG when the continuous time until completing the malfunction criteria below becomes more than the time (2.5 seconds) needed for diagnosis. Judge fail safe NG when the continuous time until completing the malfunction criteria below becomes more than time (0.1 seconds) needed for diagnosis. Judge OK and clear the NG when the malfunction criteria below are not completed.

##### Judgment value

Malfunction Criteria	Threshold Value
Output voltage	$\geq 4.88$ V

**Time Needed for Diagnosis:** 2.5 seconds

**Malfunction Indicator Light Illumination:** Illuminates as soon as malfunction occurs.

#### 6. DTC CLEAR CONDITION

- When the OK idling cycle is completed 40 times in a row
- When "Clear Memory" was performed



# DIAGNOSTIC TROUBLE CODE (DTC) DETECTING CRITERIA

GENERAL DESCRIPTION

---

## 7. MALFUNCTION INDICATOR LIGHT CLEAR CONDITION

- When the OK driving cycle is completed 3 times in a row
- When "Clear Memory" was performed

## 8. FAIL SAFE

Calculate the intake manifold pressure using the map figured by engine speed and throttle opening grid.

## 9. ECM OPERATION AT DTC SETTING

Memorize the freeze frame data. (For test mode \$02)

# DIAGNOSTIC TROUBLE CODE (DTC) DETECTING CRITERIA

## GENERAL DESCRIPTION

### L: DTC P0111 — INTAKE AIR TEMPERATURE CIRCUIT RANGE/PERFORMANCE —

#### 1. OUTLINE OF DIAGNOSIS

Detect the malfunction of intake air temperature sensor output property.

Judge NG when the intake air temperature is high regardless of the driving condition that the intake air temperature may be low.

#### 2. COMPONENT DESCRIPTION

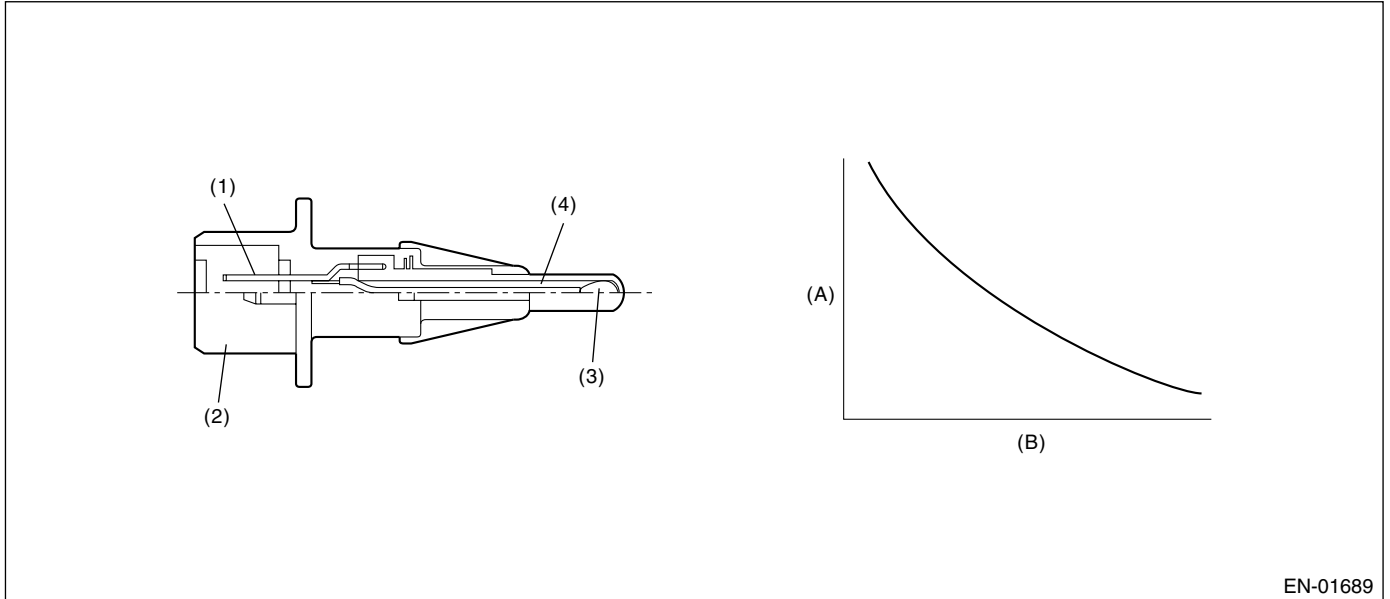

EN-01689

(1) Terminal  
(2) Connector

(3) Thermistor  
(4) Housing

(A) Resistance value ( $\Omega$ )  
(B) Intake air temperature  $^{\circ}\text{C}$  ( $^{\circ}\text{F}$ )

#### 3. ENABLE CONDITION

Secondary Parameters	Enable Conditions
Ignition switch	ON

#### 4. GENERAL DRIVING CYCLE

Always perform the diagnosis continuously.

# DIAGNOSTIC TROUBLE CODE (DTC) DETECTING CRITERIA

GENERAL DESCRIPTION

## 5. DIAGNOSTIC METHOD

### • Abnormality Judgment

Judge NG when the continuous time until completing all the malfunction criteria below becomes more than the time (3 seconds) needed for diagnosis.

### • Judgment Value

Malfunction Criteria	Threshold Value
Engine coolant temperature	< 40°C (104°F)
Fuel temperature	< 40°C (104°F)
Fuel level	10 ℓ (2.6 US gal, 2.2 Imp gal)
Intake air temperature	≥ 80°C (176°F)

**Time Needed for Diagnosis:** 3 seconds

**Malfunction Indicator Light Illumination:** Illuminates when malfunction occurs in 2 continuous driving cycles.

### • Normality Judgment

Judge OK and clear the NG when the malfunction criteria below are completed.

### • Judgment Value

Malfunction Criteria	Threshold Value
Intake air temperature	< 80°C (176°F)

## 6. DTC CLEAR CONDITION

- When the OK idling cycle is completed 40 times in a row
- When "Clear Memory" was performed

## 7. MALFUNCTION INDICATOR LIGHT CLEAR CONDITION

- When the OK driving cycle is completed 3 times in a row
- When "Clear Memory" was performed

## 8. FAIL SAFE

Make the intake air temperature 40°C (104°F).

## 9. ECM OPERATION AT DTC SETTING

Memorize the freeze frame data. (For test mode \$02)

# DIAGNOSTIC TROUBLE CODE (DTC) DETECTING CRITERIA

## GENERAL DESCRIPTION

### M: DTC P0112 — INTAKE AIR TEMPERATURE CIRCUIT LOW INPUT —

#### 1. OUTLINE OF DIAGNOSIS

Detect the open or short circuit of intake air temperature sensor.  
Judge NG when out of the standard value.

#### 2. COMPONENT DESCRIPTION

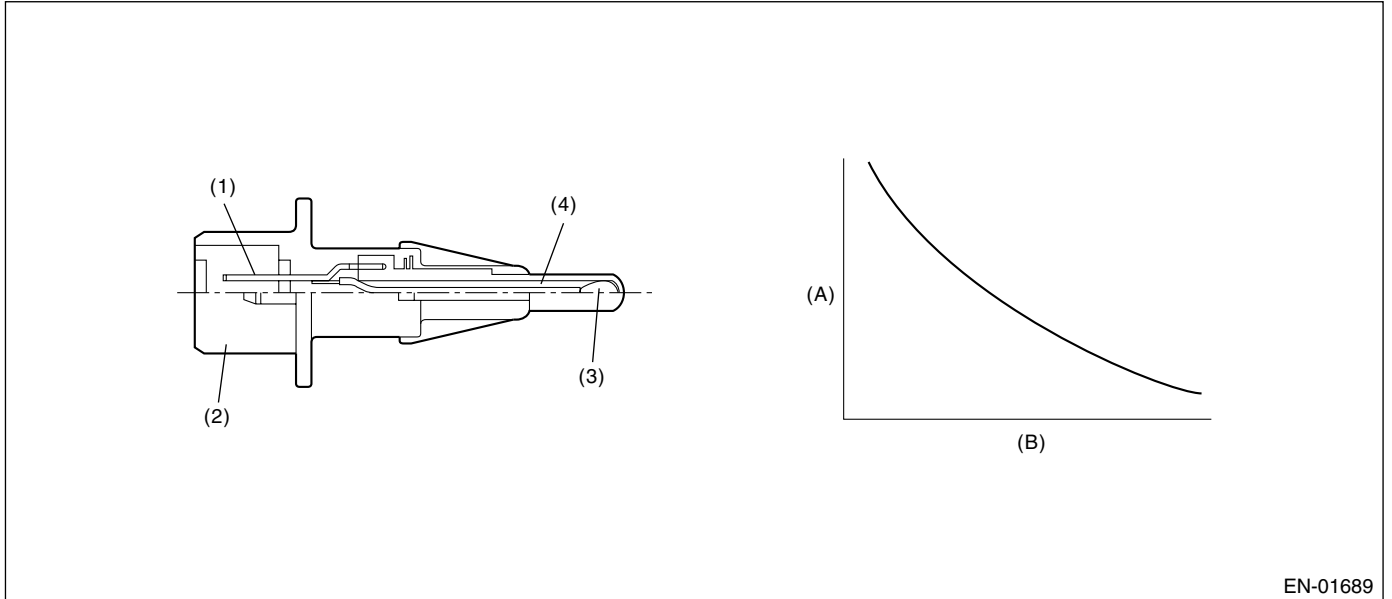

EN-01689

(1) Terminal  
(2) Connector

(3) Thermistor  
(4) Housing

(A) Resistance value ( $\Omega$ )  
(B) Intake air temperature °C (°F)

#### 3. ENABLE CONDITION

Secondary Parameters	Enable Conditions
Ignition switch	ON

#### 4. GENERAL DRIVING CYCLE

Always perform the diagnosis continuously.

#### 5. DIAGNOSTIC METHOD

Judge NG when the continuous time until completing the malfunction criteria below becomes more than the time (2.5 seconds) needed for diagnosis. Judge fail safe NG when the continuous time until completing the malfunction criteria below becomes more than the time (0.1 seconds) needed for diagnosis. Judge OK and clear the NG when the malfunction criteria below are not completed.

##### Judgment Value

Malfunction Criteria	Threshold Value
Output voltage	$\leq 0.1$ V

**Time Needed for Diagnosis:** 2.5 seconds

**Malfunction Indicator Light Illumination:** Illuminates as soon as malfunction occurs.

#### 6. DTC CLEAR CONDITION

- When the OK idling cycle is completed 40 times in a row
- When "Clear Memory" was performed

# DIAGNOSTIC TROUBLE CODE (DTC) DETECTING CRITERIA

GENERAL DESCRIPTION

---

## 7. MALFUNCTION INDICATOR LIGHT CLEAR CONDITION

- When the OK driving cycle is completed 3 times in a row
- When "Clear Memory" was performed

## 8. FAIL SAFE

Make the intake air temperature 40°C (104°F).

## 9. ECM OPERATION AT DTC SETTING

Memorize the freeze frame data. (For test mode \$02)

# DIAGNOSTIC TROUBLE CODE (DTC) DETECTING CRITERIA

## GENERAL DESCRIPTION

### N: DTC P0113 — INTAKE AIR TEMPERATURE CIRCUIT HIGH INPUT —

#### 1. OUTLINE OF DIAGNOSIS

Detect the open or short circuit of intake air temperature sensor.  
Judge NG when out of the standard value.

#### 2. COMPONENT DESCRIPTION

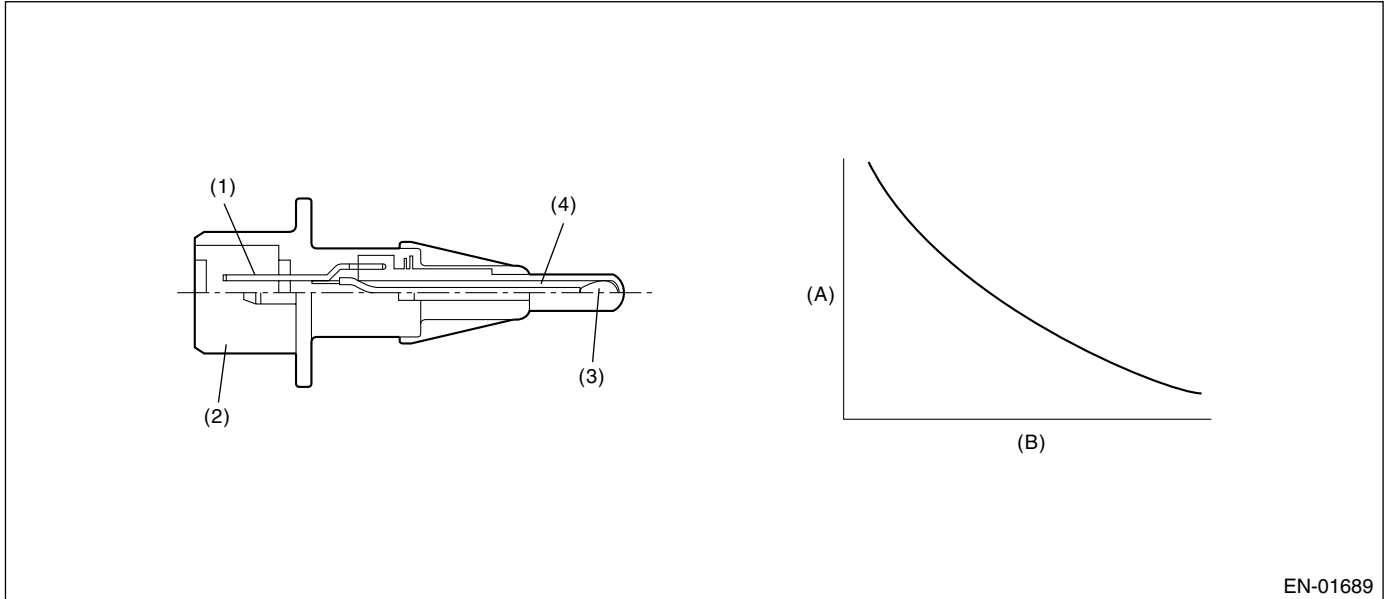

EN-01689

(1) Terminal  
(2) Connector

(3) Thermistor  
(4) Housing

(A) Resistance value (Ω)  
(B) Intake air temperature °C (°F)

#### 3. ENABLE CONDITION

Secondary Parameters	Enable Conditions
Ignition switch	ON

#### 4. GENERAL DRIVING CYCLE

Always perform the diagnosis continuously.

#### 5. DIAGNOSTIC METHOD

Judge NG when the continuous time until completing the malfunction criteria below becomes more than the time (2.5 seconds) needed for diagnosis. Judge fail safe NG when the continuous time until completing the malfunction criteria below becomes more than the time (0.1 seconds) needed for diagnosis. Judge OK and clear the NG when the malfunction criteria below are not completed.

##### Judgment Value

Malfunction Criteria	Threshold Value
Output voltage	> 4.85 V

**Time Needed for Diagnosis:** 2.5 seconds

**Malfunction Indicator Light Illumination:** Illuminates as soon as malfunction occurs.

#### 6. DTC CLEAR CONDITION

- When the OK idling cycle is completed 40 times in a row
- When "Clear Memory" was performed

# DIAGNOSTIC TROUBLE CODE (DTC) DETECTING CRITERIA

GENERAL DESCRIPTION

---

## 7. MALFUNCTION INDICATOR LIGHT CLEAR CONDITION

- When the OK driving cycle is completed 3 times in a row
- When "Clear Memory" was performed

## 8. FAIL SAFE

Make the intake air temperature 40°C (104°F).

## 9. ECM OPERATION AT DTC SETTING

Memorize the freeze frame data. (For test mode \$02)

# DIAGNOSTIC TROUBLE CODE (DTC) DETECTING CRITERIA

## GENERAL DESCRIPTION

### O: DTC P0117 — ENGINE COOLANT TEMPERATURE CIRCUIT LOW INPUT —

#### 1. OUTLINE OF DIAGNOSIS

Detect the open or short circuit of engine coolant temperature sensor.  
Judge NG when out of the standard value.

#### 2. COMPONENT DESCRIPTION

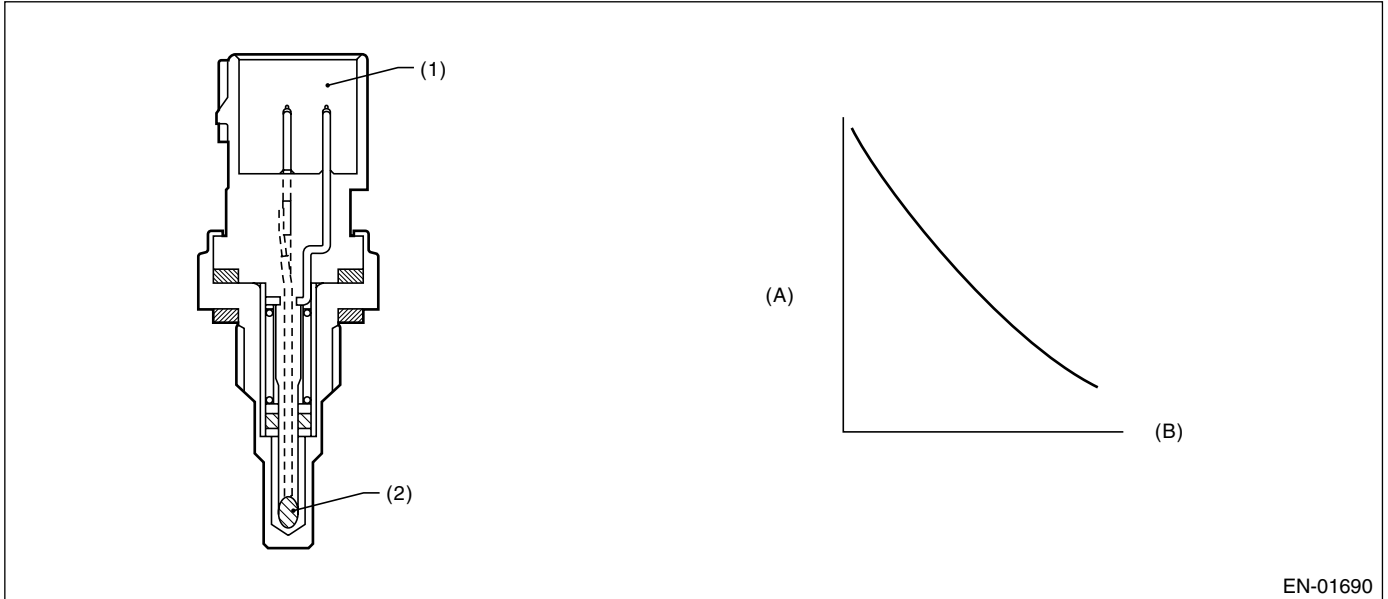

EN-01690

- (1) Connector
- (2) Thermistor element
- (A) Resistance value (k $\Omega$ )
- (B) Temperature °C (°F)

#### 3. ENABLE CONDITION

Secondary Parameters	Enable Conditions
None	

#### 4. GENERAL DRIVING CYCLE

Always perform the diagnosis continuously.

#### 5. DIAGNOSTIC METHOD

Judge NG when the continuous time until completing the malfunction criteria below becomes more than the time (2.5 seconds) needed for diagnosis.

Judge fail safe NG when the continuous time until completing the malfunction criteria below becomes more than the time (0.2 seconds) needed for diagnosis. Judge OK and clear the NG when the malfunction criteria below are not completed.

##### Judgment Value

Malfunction Criteria	Threshold Value
Output voltage	$\leq 0.1$ V

**Time Needed for Diagnosis:** 2.5 seconds

**Malfunction Indicator Light Illumination:** Illuminates as soon as malfunction occurs.

#### 6. DTC CLEAR CONDITION

- When the OK idling cycle was completed 40 times in a row
- When "Clear Memory" was performed



# DIAGNOSTIC TROUBLE CODE (DTC) DETECTING CRITERIA

GENERAL DESCRIPTION

---

## 7. MALFUNCTION INDICATOR LIGHT CLEAR CONDITION

- When the OK driving cycle was completed 3 times in a row
- When "Clear Memory" was performed

## 8. FAIL SAFE

Keep the engine coolant temperature at 70°C (158°F).

## 9. ECM OPERATION AT DTC SETTING

Memorize the freeze frame data. (For test mode \$02)

# DIAGNOSTIC TROUBLE CODE (DTC) DETECTING CRITERIA

## GENERAL DESCRIPTION

### P: DTC P0118 — ENGINE COOLANT TEMPERATURE CIRCUIT HIGH INPUT —

#### 1. OUTLINE OF DIAGNOSIS

Detect the open or short circuit of engine coolant temperature sensor.  
Judge NG when out of the standard value.

#### 2. COMPONENT DESCRIPTION

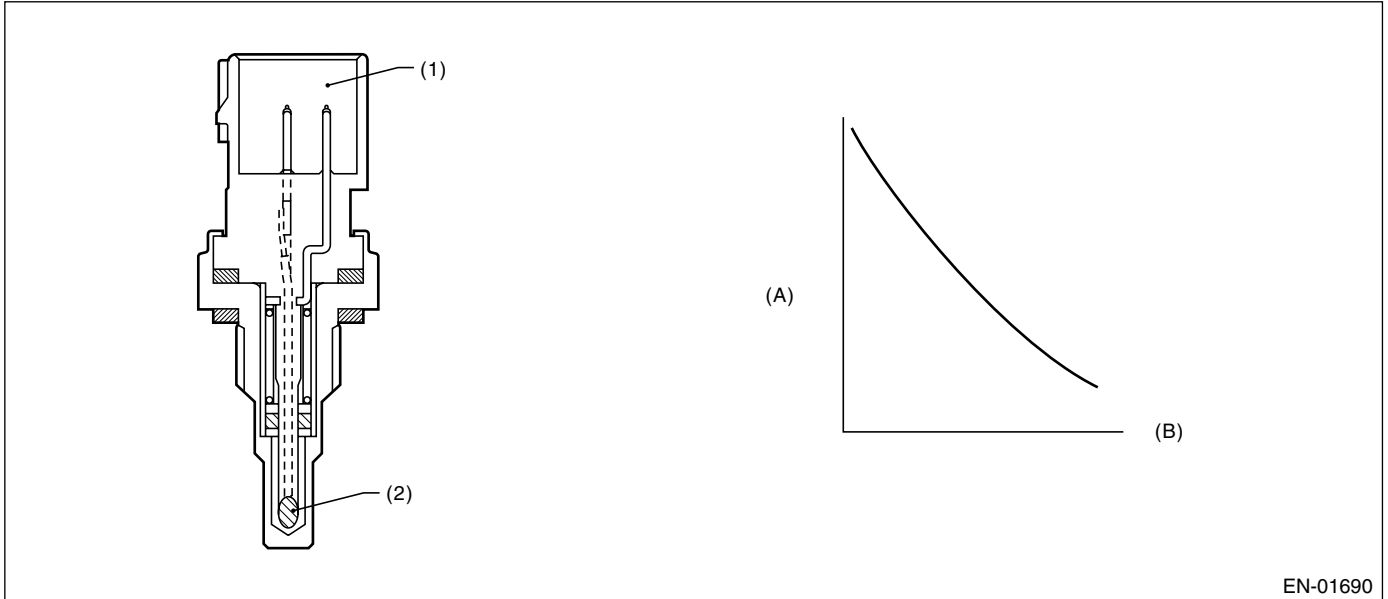

EN-01690

- (1) Connector
- (2) Thermistor element
- (A) Resistance value (k $\Omega$ )
- (B) Temperature °C (°F)

#### 3. ENABLE CONDITION

Secondary Parameters	Enable Conditions
None	

#### 4. GENERAL DRIVING CYCLE

Always perform the diagnosis continuously after starting the engine.

#### 5. DIAGNOSTIC METHOD

Judge NG when the continuous time until completing the malfunction criteria below becomes more than the time (2.5 seconds) needed for diagnosis.

Judge fail safe NG when the continuous time until completing the malfunction criteria below becomes more than the time (0.2 seconds) needed for diagnosis. Judge OK and clear the NG when the malfunction criteria below are not completed.

##### Judgment Value

Malfunction Criteria	Threshold Value
Output voltage	$\geq 4.85$ V

**Time Needed for Diagnosis:** 2.5 seconds

**Malfunction Indicator Light Illumination:** Illuminates as soon as malfunction occurs.

#### 6. DTC CLEAR CONDITION

- When the OK idling cycle was completed 40 times in a row
- When "Clear Memory" was performed

# DIAGNOSTIC TROUBLE CODE (DTC) DETECTING CRITERIA

GENERAL DESCRIPTION

---

## 7. MALFUNCTION INDICATOR LIGHT CLEAR CONDITION

- When the OK driving cycle was completed 3 times in a row
- When "Clear Memory" was performed

## 8. FAIL SAFE

Keep the engine coolant temperature at 70°C (158°F).

## 9. ECM OPERATION AT DTC SETTING

Memorize the freeze frame data. (For test mode \$02)

# DIAGNOSTIC TROUBLE CODE (DTC) DETECTING CRITERIA

## GENERAL DESCRIPTION

### Q: DTC P0121 — THROTTLE/PEDAL POSITION SENSOR/SWITCH “A” CIRCUIT RANGE/PERFORMANCE —

#### 1. OUTLINE OF DIAGNOSIS

Detect the malfunction of throttle position sensor output property.

Judge NG when the throttle position value is low in spite of the driving condition that accelerator pedal seems to be depressed, or when the throttle position value is high in spite of the driving condition that accelerator pedal seems to be released from engine appearance.

#### 2. COMPONENT DESCRIPTION

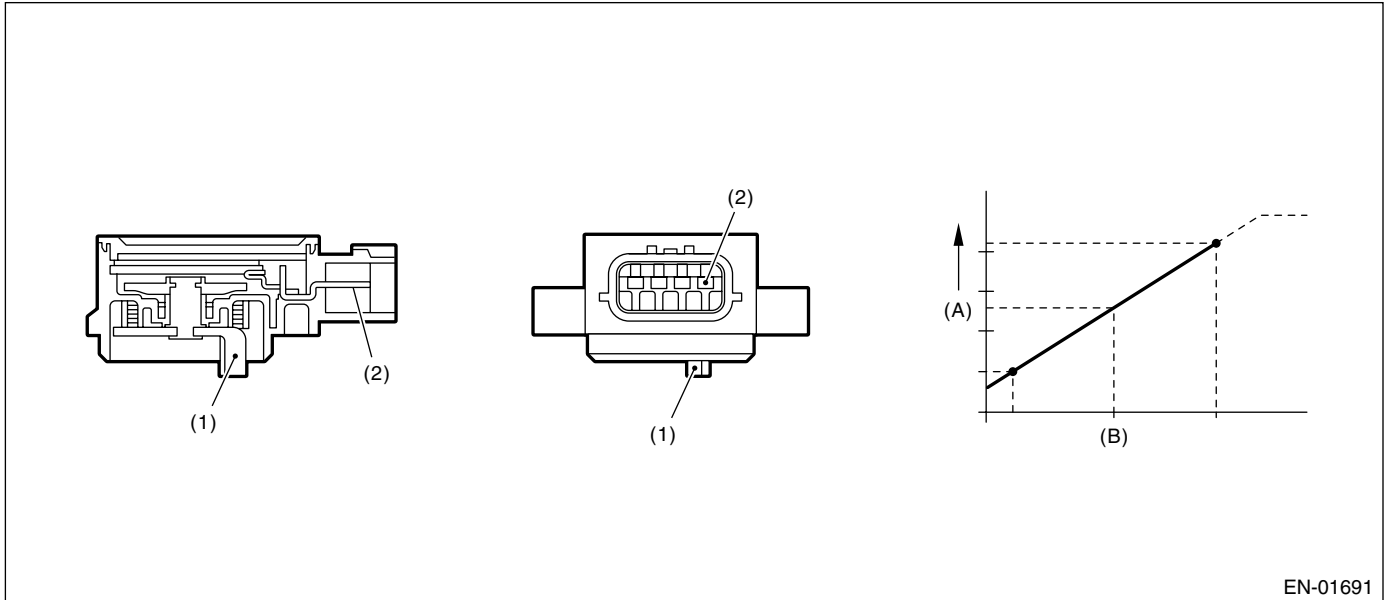

EN-01691

- (1) Lever
- (2) Terminal

- (A) Output voltage
- (B) Throttle angle

#### 3. ENABLE CONDITION

Secondary Parameters	Enable Conditions
Coolant temperature	$\geq 75^{\circ}\text{C}$ ( $167^{\circ}\text{F}$ )

#### 4. GENERAL DRIVE CYCLE

Perform the diagnosis continuously after starting engine.

# DIAGNOSTIC TROUBLE CODE (DTC) DETECTING CRITERIA

GENERAL DESCRIPTION

## 5. DIAGNOSTIC METHOD

### • Abnormality Judgment

Judge NG when the continuous time of completing the malfunction criteria of Low side or High side below becomes more than time needed for diagnosis.

### • Judgment Value

Malfunction Criteria	Threshold Value
(Low side)	
Output voltage	$\leq 0.75$ V
Engine speed	$\geq 1000$ rpm
Amount of intake air	$\geq 90$ kg (198 lb)/h
Intake manifold pressure	$\geq 80$ kPa (600 mmHg, 24 inHg)
(High side)	
Output voltage	$\geq 1.6$ V
Engine speed	600 — 1500 rpm
Amount of intake air	$\leq 25$ kg (55 lb)/h
Intake manifold pressure	$\leq 47$ kPa (352 mmHg, 14 inHg)

### • Time Needed for Diagnosis:

Low side	3 seconds
High side	10 seconds

**Malfunction Indicator Light Illumination:** Illuminates when malfunction occurs in 2 continuous driving cycles.

### • Normality Judgment

Judge OK and clear the NG when the malfunction criteria below are completed.

### • Judgment Value

Malfunction Criteria	Threshold Value
(Low side)	
Output voltage	$> 0.75$ V
Engine speed	$\geq 1000$ rpm
Amount of intake air	$\geq 90$ kg (198 lb)/h
Intake manifold pressure	$\geq 80$ kPa (600 mmHg, 24 inHg)
(High side)	
Output voltage	$\leq 1.6$ V
Engine speed	600 — 1500 rpm
Amount of intake air	$\leq 25$ kg (55 lb)/h
Intake manifold pressure	$\leq 47$ kPa (352 mmHg, 14 inHg)

## 6. DTC CLEAR CONDITION

- When the OK idling cycle is completed 40 times in a row
- When "Clear Memory" was performed

## 7. MALFUNCTION INDICATOR LIGHT CLEAR CONDITION

- When the OK driving cycle was completed 3 times in a row
- When "Clear Memory" was performed

## 8. FAIL SAFE

Fix the throttle position to 6.4°.

# DIAGNOSTIC TROUBLE CODE (DTC) DETECTING CRITERIA

## GENERAL DESCRIPTION

---

### 9. ECM OPERATION AT DTC SETTING

Memorize the freeze frame data. (For test mode \$02)

# DIAGNOSTIC TROUBLE CODE (DTC) DETECTING CRITERIA

GENERAL DESCRIPTION

---

MEMO:

# DIAGNOSTIC TROUBLE CODE (DTC) DETECTING CRITERIA

## GENERAL DESCRIPTION

### R: DTC P0122 — THROTTLE/PEDAL POSITION SENSOR/SWITCH “A” CIRCUIT LOW INPUT —

#### 1. OUTLINE OF DIAGNOSIS

Detect the open or short circuit of throttle position sensor.  
Judge NG when out of the standard value.

#### 2. COMPONENT DESCRIPTION

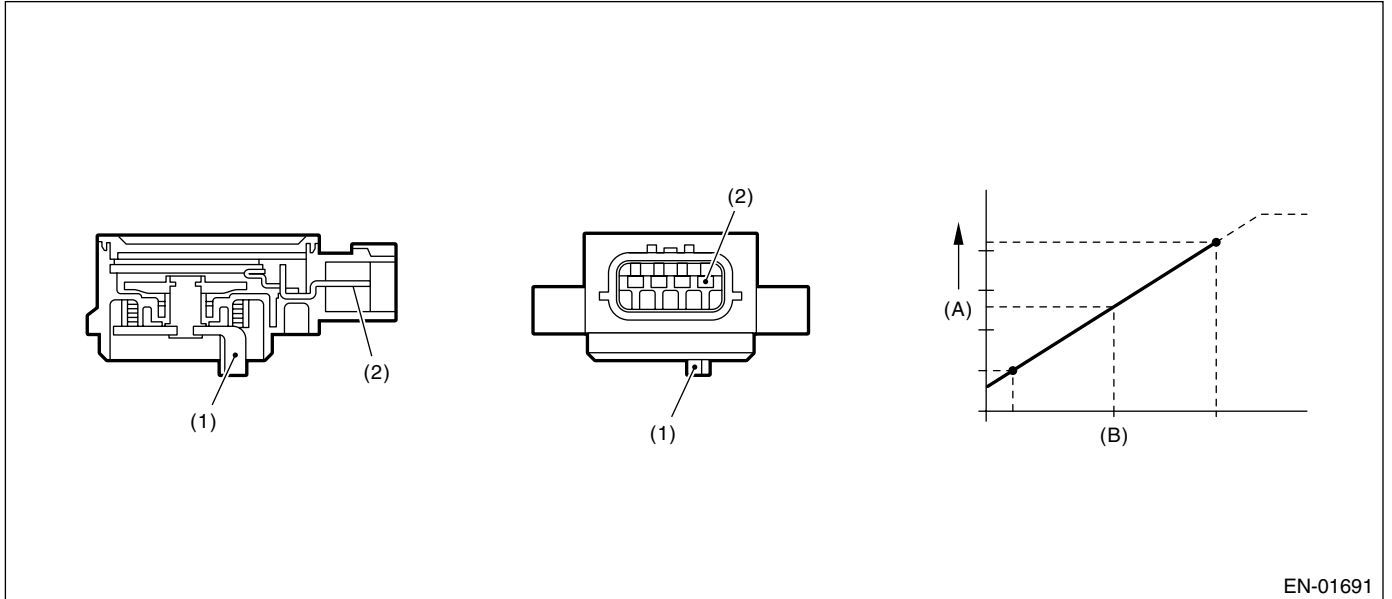

EN-01691

- (1) Lever
- (2) Terminal

- (A) Output voltage
- (B) Throttle angle

#### 3. ENABLE CONDITION

Secondary Parameters	Enable Conditions
Ignition switch	ON

#### 4. GENERAL DRIVE CYCLE

Always perform the diagnosis continuously.

#### 5. DIAGNOSTIC METHOD

Judge NG when the continuous time until completing the malfunction criteria below becomes more than the time (2.5 seconds) needed for diagnosis.

Judge fail safe NG when the continuous time until completing the malfunction criteria below becomes more than the time (0.1 seconds) needed for diagnosis. Judge OK and clear the NG when the malfunction criteria below are completed.

##### Judgment Value

Malfunction Criteria	Threshold Value
Output voltage — closed	$\leq 0.1$ V

**Time Needed for Diagnosis:** 2.5 seconds

**Malfunction Indicator Light Illumination:** Illuminates as soon as malfunction occurs.

#### 6. DTC CLEAR CONDITION

- When the OK idling cycle is completed 40 times in a row
- When “Clear Memory” was performed



# DIAGNOSTIC TROUBLE CODE (DTC) DETECTING CRITERIA

GENERAL DESCRIPTION

---

## 7. MALFUNCTION INDICATOR LIGHT CLEAR CONDITION

- When the OK driving cycle was completed 3 times in a row
- When "Clear Memory" was performed

## 8. FAIL SAFE

Fix the throttle position to 6.4°.

## 9. ECM OPERATION AT DTC SETTING

Memorize the freeze frame data. (For test mode \$02)

# DIAGNOSTIC TROUBLE CODE (DTC) DETECTING CRITERIA

## GENERAL DESCRIPTION

### S: DTC P0123 — THROTTLE/PEDAL POSITION SENSOR/SWITCH “A” CIRCUIT HIGH INPUT —

#### 1. OUTLINE OF DIAGNOSIS

Detect the open or short circuit of throttle position sensor.  
Judge NG when out of the standard value.

#### 2. COMPONENT DESCRIPTION

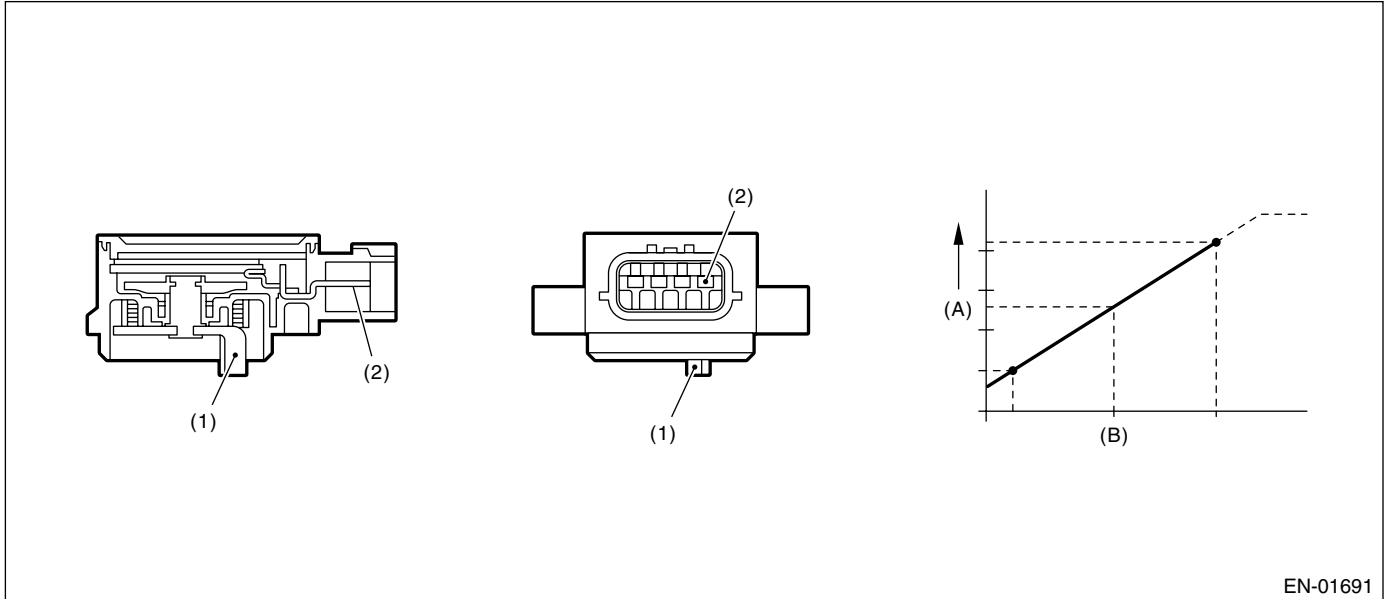

EN-01691

- (1) Lever
- (2) Terminal

- (A) Output voltage
- (B) Throttle angle

#### 3. ENABLE CONDITION

Secondary Parameters	Enable Conditions
Ignition switch	ON

#### 4. GENERAL DRIVE CYCLE

Always perform the diagnosis continuously.

#### 5. DIAGNOSTIC METHOD

Judge NG when the continuous time until completing the malfunction criteria below becomes more than the time (2.5 seconds) needed for diagnosis.

Judge fail safe NG when the continuous time until completing the malfunction criteria below becomes more than the time (0.1 seconds) needed for diagnosis. Judge OK and clear the NG when the malfunction criteria below are completed.

##### Judgment Value

Malfunction Criteria	Threshold Value
Output voltage — WOT	$\geq 4.9$ V

**Time Needed for Diagnosis:** 2.5 seconds

**Malfunction Indicator Light Illumination:** Illuminates as soon as malfunction occurs.

#### 6. DTC CLEAR CONDITION

- When the OK idling cycle is completed 40 times in a row
- When “Clear Memory” was performed

# DIAGNOSTIC TROUBLE CODE (DTC) DETECTING CRITERIA

GENERAL DESCRIPTION

---

## 7. MALFUNCTION INDICATOR LIGHT CLEAR CONDITION

- When the OK driving cycle was completed 3 times in a row
- When "Clear Memory" was performed

## 8. FAIL SAFE

Fix the throttle position to 6.4°.

## 9. ECM OPERATION AT DTC SETTING

Memorize the freeze frame data. (For test mode \$02)

# DIAGNOSTIC TROUBLE CODE (DTC) DETECTING CRITERIA

## GENERAL DESCRIPTION

### T: DTC P0125 — INSUFFICIENT COOLANT TEMPERATURE FOR CLOSED LOOP FUEL CONTROL —

#### 1. OUTLINE OF DIAGNOSIS

Detect the malfunction of engine coolant temperature sensor output property. Judge NG when the engine coolant temperature does not increase after engine starting in spite of the driving condition that it seems to increase.

#### 2. ENABLE CONDITION

Secondary Parameters	Enable Conditions
None	

#### 3. GENERAL DRIVE CYCLE

Always perform the diagnosis until the engine coolant temperature becomes 20°C (68°F) after starting engine with cooled condition or until NG is judged once.

#### 4. DIAGNOSTIC METHOD

Judge NG when the malfunction criteria below are completed. Judge OK and clear NG when the engine coolant temperature is more than 20°C (68°F) or more.

##### Judgment Value

Malfunction Criteria	Threshold Value
Output voltage	$\leq 0.38$ V
Timer after starting the engine except fuel cut	$\geq$ Judgment time
a) Timer OFF of fuel cut mode.	
b) The timer is counted more than 50ms + TWCNT milliseconds per 50 milliseconds under driving condition without above. TWCNT is determined as following.	
• Idle switch ON: TWCNT = 0	
• Idle switch OFF: Refer to Map 1	

##### Map 1

	Vehicle speed 10 km/h (6 MPH)	Vehicle speed 24 km/h (15 MPH)	Vehicle speed 40 km/h (25 MPH)	Vehicle speed 56 km/h (35 MPH)
Temperature -20°C (-4°F)	0 ms	5 ms	10 ms	20 ms
Temperature -7°C (19°F)	0 ms	30 ms	60 ms	60 ms
Temperature 10°C (50°F)	0 ms	90 ms	180 ms	180 ms
Temperature 20°C (68°F)	0 ms	90 ms	180 ms	180 ms

##### Judgment time: Find from minimum engine coolant temperature.

Minimum engine coolant temperature °C (°F)	-30 (- 22)	0 (32)	30 (86)	60 (140)	64.25 (147.65)
Judgment time (second)	630.05	429.5	228.95	28.4	0

**Time Needed for Diagnosis:** Change at minimum engine coolant temperature.

**Malfunction Indicator Light Illumination:** Illuminates when malfunction occurs in 2 continuous driving cycles.

#### 5. DTC CLEAR CONDITION

- When the OK idling cycle was completed 40 times in a row
- When "Clear Memory" was performed

# DIAGNOSTIC TROUBLE CODE (DTC) DETECTING CRITERIA

GENERAL DESCRIPTION

---

## 6. MALFUNCTION INDICATOR LIGHT CLEAR CONDITION

- When the OK driving cycle was completed 3 times in a row
- When "Clear Memory" was performed

## 7. FAIL SAFE

Keep engine coolant temperature at 70°C (158°F).

## 8. ECM OPERATION AT DTC SETTING

Memorize the freeze frame data. (For test mode \$02)

# DIAGNOSTIC TROUBLE CODE (DTC) DETECTING CRITERIA

## GENERAL DESCRIPTION

### U: DTC P0128 — COOLANT THERMOSTAT (COOLANT TEMPERATURE BELOW THERMOSTAT REGULATING TEMPERATURE) —

#### 1. OUTLINE OF DIAGNOSIS

Detect the malfunction of thermostat.

Thermostat open fixing may result in overcooling. Therefore, engine coolant temperature becomes low and the control is unable under theoretical air fuel ratio, so the exhaust deteriorate. Furthermore, it is impossible to perform the other diagnosis if the engine coolant temperature does not rise. For these reasons, thermostat open fixing diagnosis should be conducted.

Judge NG when the estimated engine coolant temperature is higher than engine coolant temperature and the difference between them is large. Judge OK when the engine coolant temperature becomes 75°C (167°F) before judging NG.

#### 2. COMPONENT DESCRIPTION

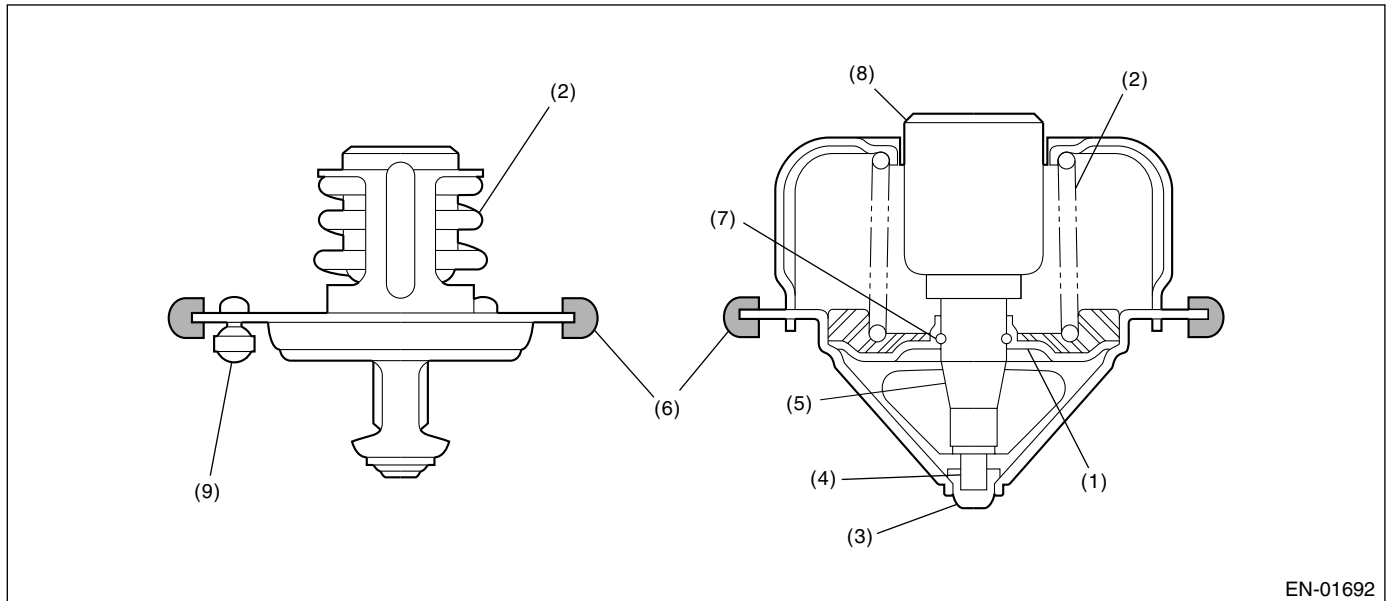

- |             |                    |                  |
|-------------|--------------------|------------------|
| (1) Valve   | (4) Piston         | (7) Stop ring    |
| (2) Spring  | (5) Guide          | (8) Wax element  |
| (3) Stopper | (6) Rubber packing | (9) Jiggle valve |

#### 3. ENABLE CONDITION

Secondary Parameters	Enable Conditions
Ambient air temperature	$\geq -7^{\circ}\text{C}$ (19°F)
Engine coolant temperature at engine starting	$< 55^{\circ}\text{C}$ (131°F)

#### 4. GENERAL DRIVING CYCLE

After starting the engine at cool condition, always perform the diagnosis until the engine coolant temperature becomes more than 75°C (167°F).

# DIAGNOSTIC TROUBLE CODE (DTC) DETECTING CRITERIA

GENERAL DESCRIPTION

## 5. DIAGNOSTIC METHOD

Judge NG when the estimated engine coolant temperature comes to 75°C (167°F) before the engine coolant temperature becomes 75°C (167°F) and the difference between them becomes more than 30°C (86°F). Judge OK when the engine coolant temperature comes to 75°C (167°F) before judging NG.

### • Abnormality Judgment

Judge NG when the cumulative time becomes more than 30 seconds after completing all the malfunction criteria below.

### • Judgment Value

Malfunction Criteria	Threshold Value
(Estimated-measured) coolant temperature	> 30°C (86°F)
Engine coolant temperature	< 75°C (167°F)
Estimated coolant temperature	≥ 75°C (167°F)
Vehicle speed	≥ 40 km/h (25 MPH)
Injector pulse	≥ 1.92 milliseconds

**Time Needed for Diagnosis:** 30 seconds

**Malfunction Indicator Light Illumination:** Illuminates when malfunction occurs in 2 continuous driving cycles.

### • Normality Judgment

Judge OK and clear the NG when all the malfunction criteria below are completed.

### • Judgment Value

Malfunction Criteria	Threshold Value
(Estimated-measured) coolant temperature	≤ 30°C (86°F)
Engine coolant temperature	≥ 75°C (167°F)

## 6. DTC CLEAR CONDITION

- When the OK idling cycle is completed 40 times in a row
- When "Clear Memory" was performed

## 7. MALFUNCTION INDICATOR LIGHT CLEAR CONDITION

- When the OK driving cycle is completed 3 times in a row
- When "Clear Memory" was performed

## 8. FAIL SAFE

None

## 9. ECM OPERATION AT DTC SETTING

- Memorize the freeze frame data. (For test mode \$02)
- Memorize the diagnostic value and trouble standard value. (For test mode \$06)

# DIAGNOSTIC TROUBLE CODE (DTC) DETECTING CRITERIA

## GENERAL DESCRIPTION

### V: DTC P0129 — BAROMETRIC PRESSURE TOO LOW —

#### 1. OUTLINE OF DIAGNOSIS

Detect the malfunction of atmospheric pressure sensor output property.

Intake manifold pressure and atmospheric pressure are the same from turning the IG key to ON to turning the start SW to ON. Therefore, compare the pressure from intake manifold pressure and atmospheric pressure sensors, and then judge NG when their difference is large.

#### 2. COMPONENT DESCRIPTION

Atmospheric pressure sensor is built in ECM.

#### 3. ENABLE CONDITION

Secondary Parameters	Enable Conditions
Ignition switch	ON
Neutral switch	ON
Engine speed	< 500 rpm
Vehicle speed	< 2 km/h (1 MPH)
(Max-min) manifold absolute pressure output	< 1.2 kPa (9 mmHg, 0.4 inHg)

#### 4. GENERAL DRIVING CYCLE

Perform the diagnosis only once from the IG key turned to ON to the start SW turned to ON.

#### 5. DIAGNOSTIC METHOD

Judge NG when the continuous time until completing the malfunction criteria below becomes more than the time (0.2 seconds) needed for diagnosis. Judge OK when the malfunction criteria below are not completed.

##### Judgment Value

Malfunction Criteria	Threshold Value
Atmospheric-manifold absolute pressure	≥ 27 kPa (200 mmHg, 8 inHg)

**Time Needed for Diagnosis:** 0.2 seconds

**Malfunction Indicator Light Illumination:** Illuminates when malfunction occurs in 2 continuous driving cycles.

#### 6. DTC CLEAR CONDITION

- When the OK idling cycle is completed 40 times in a row
- When "Clear Memory" was performed

#### 7. MALFUNCTION INDICATOR LIGHT CLEAR CONDITION

- When the OK driving cycle is completed 3 times in a row
- When "Clear Memory" was performed

#### 8. FAIL SAFE

Make the atmospheric pressure 101 kPa (760 mmHg, 29.8 inHg).

#### 9. ECM OPERATION AT DTC SETTING

Memorize the freeze frame data. (For test mode \$02)



# DIAGNOSTIC TROUBLE CODE (DTC) DETECTING CRITERIA

GENERAL DESCRIPTION

---

MEMO:

# DIAGNOSTIC TROUBLE CODE (DTC) DETECTING CRITERIA

## GENERAL DESCRIPTION

### W: DTC P0130 — O<sub>2</sub> SENSOR CIRCUIT (BANK 1 SENSOR 1) —

#### 1. OUTLINE OF DIAGNOSIS

Detect the malfunction of front oxygen (A/F) sensor output property.  
Judge NG when the front oxygen (A/F) sensor output continues to be lean.

#### 2. COMPONENT DESCRIPTION

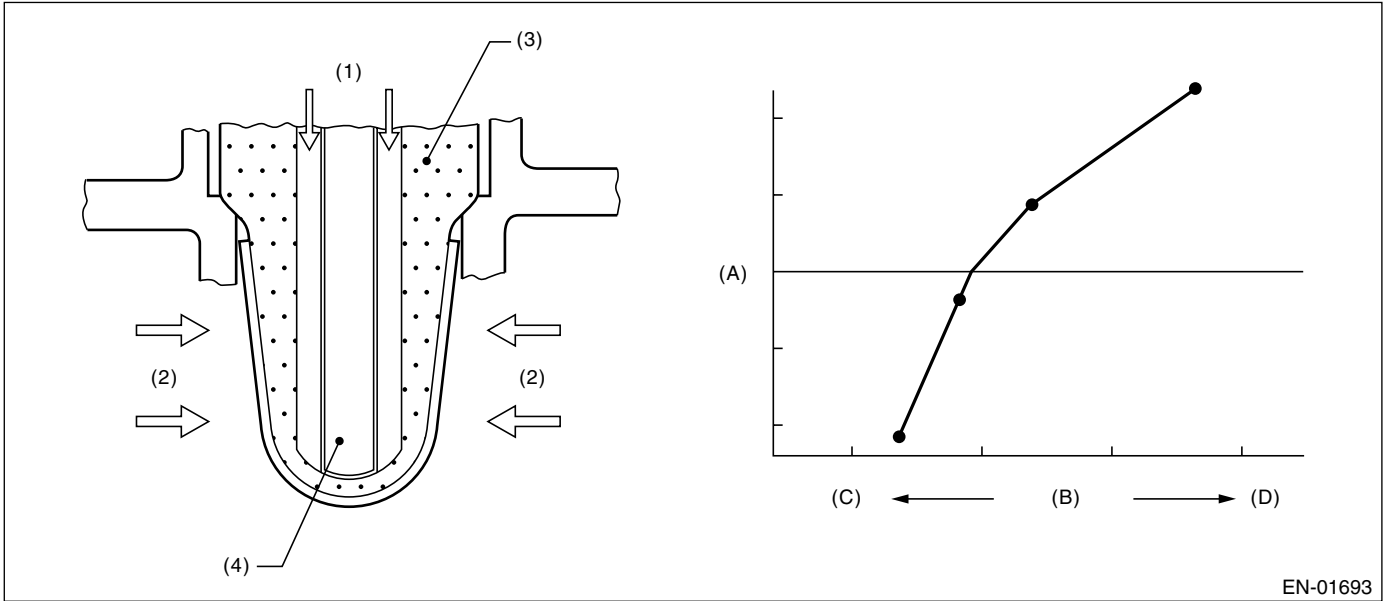

EN-01693

- |                      |                         |
|----------------------|-------------------------|
| (1) Atmosphere       | (A) Electromotive force |
| (2) Exhaust gas      | (B) Air fuel ratio      |
| (3) ZrO <sub>2</sub> | (C) Lean                |
| (4) Ceramic heater   | (D) Rich                |

#### 3. ENABLE CONDITION

Secondary Parameters	Enable Conditions
Closed loop control	In operation
Fuel shut-off event	Not in operation
Misfire rate during 200 engine revs.	≤ 1.0%
After engine starting	230 seconds or more
Engine coolant temperature	≥ 75°C (167°F)

#### 4. GENERAL DRIVING CYCLE

Perform the diagnosis continuously in 230 seconds after engine starting.

# DIAGNOSTIC TROUBLE CODE (DTC) DETECTING CRITERIA

GENERAL DESCRIPTION

## 5. DIAGNOSTIC METHOD

### • Abnormality Judgment

Judge NG when the continuous time of completing all the malfunction criteria below becomes more than the time (10 seconds) needed for diagnosis

### • Judgment Value

Malfunction Criteria	Threshold Value
A/F sensor output (VAF)	> 2.3 V (lean)
Lambda fudge factor (LAMBDA)	= Rich clamp at MAX limiter (1.375)

**Time Needed for Diagnosis:** 10 seconds

**Malfunction Indicator Light Illumination:** Illuminates as soon as malfunction occurs.

### • Normality Judgment

Judge OK when the cumulative time until completing all the malfunction criteria below becomes more than the time (10 seconds) needed for diagnosis

### • Judgment Value

Malfunction Criteria	Threshold Value
A/F sensor output (VAF)	$\leq 2.3$ V

## 6. DTC CLEAR CONDITION

- When the OK idling cycle was completed 40 times in a row
- When "Clear Memory" was performed

## 7. MALFUNCTION INDICATOR LIGHT CLEAR CONDITION

- When the OK driving cycle was completed 3 times in a row
- When "Clear Memory" was performed

## 8. FAIL SAFE

None

## 9. ECM OPERATION AT DTC SETTING

Memorize the freeze frame data. (For test mode \$02)

# DIAGNOSTIC TROUBLE CODE (DTC) DETECTING CRITERIA

## GENERAL DESCRIPTION

### X: DTC P0131 — O<sub>2</sub> SENSOR CIRCUIT LOW VOLTAGE (BANK 1 SENSOR 1) —

#### 1. OUTLINE OF DIAGNOSIS

Detect the low voltage short circuit of front oxygen (A/F) sensor.

Diagnosis is performed using A/F microcomputer, and communication is established between A/F microcomputer and main microcomputer. Judge NG when the data of low voltage short circuit NG is transmitted.

#### 2. COMPONENT DESCRIPTION

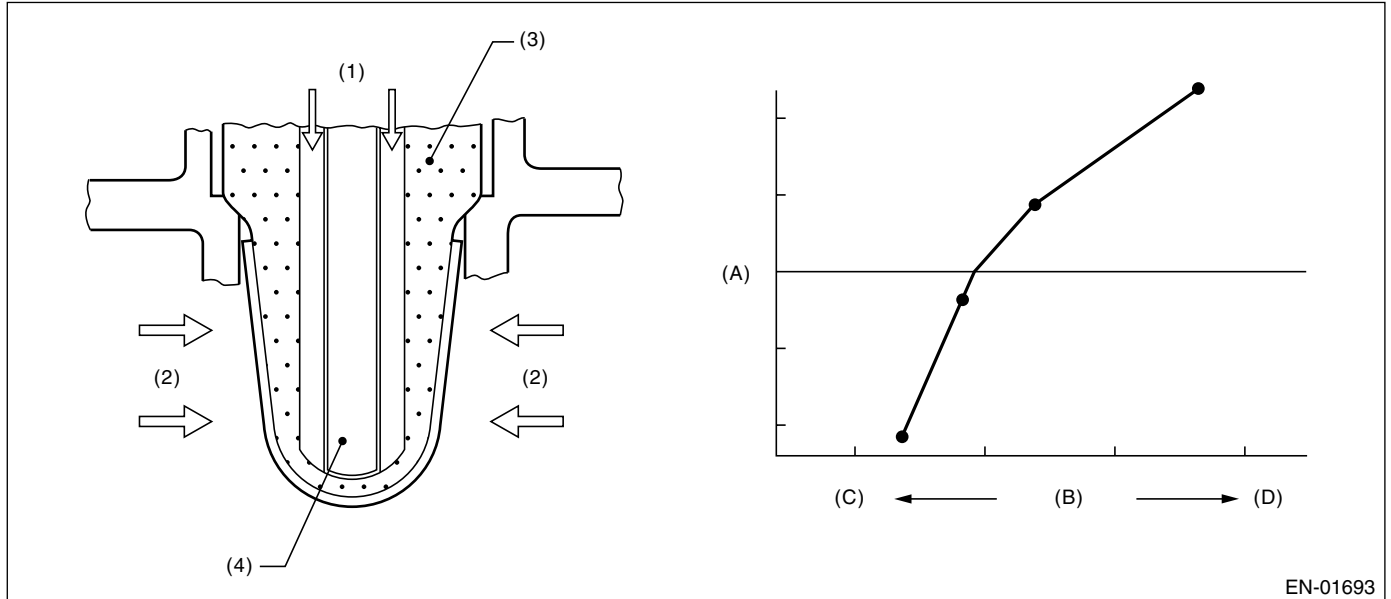

EN-01693

- |                      |                         |
|----------------------|-------------------------|
| (1) Atmosphere       | (A) Electromotive force |
| (2) Exhaust gas      | (B) Air fuel ratio      |
| (3) ZrO <sub>2</sub> | (C) Lean                |
| (4) Ceramic heater   | (D) Rich                |

#### 3. ENABLE CONDITION

Secondary Parameters	Enable Conditions
None	

#### 4. GENERAL DRIVING CYCLE

Terminate the diagnosis if the open circuit, low voltage short circuit or high voltage short circuit becomes NG once by performing diagnosis continuously.

#### 5. DIAGNOSTIC METHOD

Judge NG when the malfunction criteria below is completed.

##### Judgment Value

Malfunction Criteria	Threshold Value
AFC voltage	< 3.5 V
AFV voltage	< 2.5 V

**Time Needed for Diagnosis:** 5 seconds

**Malfunction Indicator Light Illumination:** Illuminates as soon as malfunction occurs.

#### 6. DTC CLEAR CONDITION

- When the OK idling cycle was completed 40 times in a row
- When "Clear Memory" was performed

# DIAGNOSTIC TROUBLE CODE (DTC) DETECTING CRITERIA

GENERAL DESCRIPTION

---

## 7. MALFUNCTION INDICATOR LIGHT CLEAR CONDITION

- When the OK driving cycle was completed 3 times in a row
- When "Clear Memory" was performed

## 8. FAIL SAFE

None

## 9. ECM OPERATION AT DTC SETTING

Memorize the freeze frame data. (For test mode \$02)

# DIAGNOSTIC TROUBLE CODE (DTC) DETECTING CRITERIA

## GENERAL DESCRIPTION

### Y: DTC P0132 — O<sub>2</sub> SENSOR CIRCUIT HIGH VOLTAGE (BANK 1 SENSOR 1) —

#### 1. OUTLINE OF DIAGNOSIS

Detect the high voltage short circuit of front oxygen (A/F) sensor.

Diagnosis is performed using A/F microcomputer, and communication is established between A/F microcomputer and main microcomputer. Judge NG when the data of high voltage short circuit NG is transmitted.

#### 2. COMPONENT DESCRIPTION

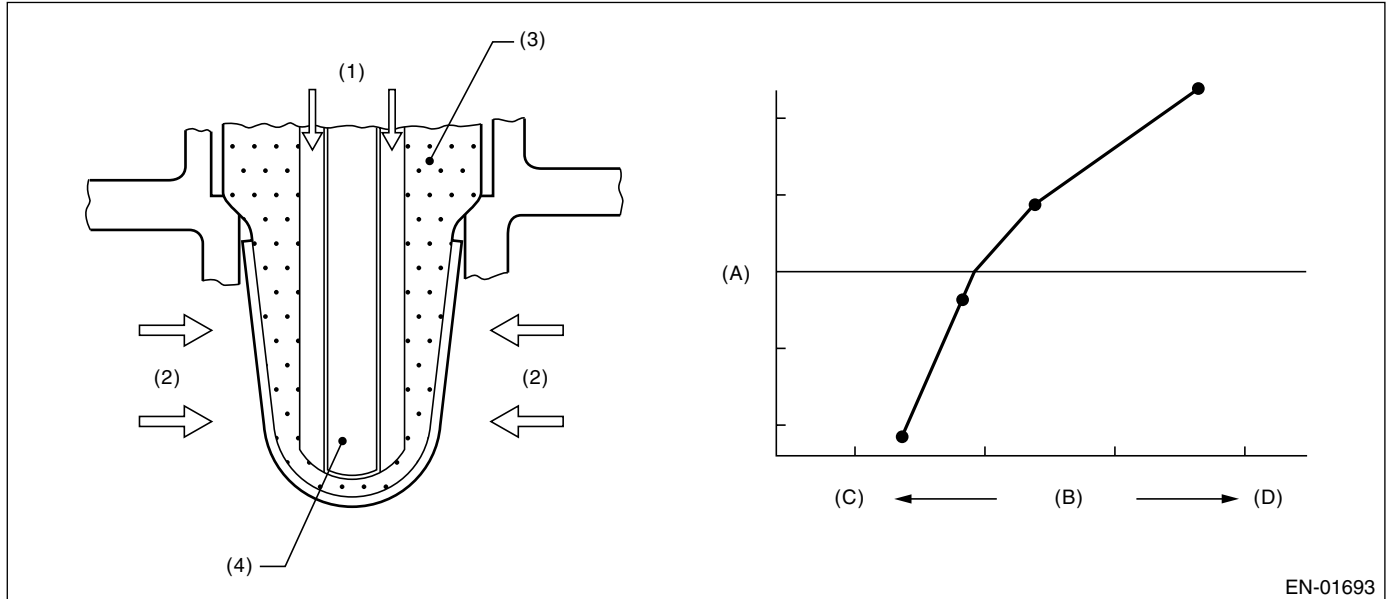

EN-01693

- |                      |                         |
|----------------------|-------------------------|
| (1) Atmosphere       | (A) Electromotive force |
| (2) Exhaust gas      | (B) Air fuel ratio      |
| (3) ZrO <sub>2</sub> | (C) Lean                |
| (4) Ceramic heater   | (D) Rich                |

#### 3. ENABLE CONDITION

Secondary Parameters	Enable Conditions
None	

#### 4. GENERAL DRIVING CYCLE

Terminate the diagnosis if the open circuit, low voltage short circuit or high voltage short circuit becomes NG once by performing diagnosis continuously.

#### 5. DIAGNOSTIC METHOD

Judge NG when the continuous time of completing the malfunction criteria below becomes more than the time (5 seconds) needed for diagnosis.

##### Judgment Value

Malfunction Criteria	Threshold Value
AFC voltage	> 4.5 V
AFV voltage	> 5.0 V

**Time Needed for Diagnosis:** 5 seconds

**Malfunction Indicator Light Illumination:** Illuminates as soon as malfunction occurs.

#### 6. DTC CLEAR CONDITION

- When the OK idling cycle was completed 40 times in a row
- When "Clear Memory" was performed

# DIAGNOSTIC TROUBLE CODE (DTC) DETECTING CRITERIA

GENERAL DESCRIPTION

---

## 7. MALFUNCTION INDICATOR LIGHT CLEAR CONDITION

- When the OK driving cycle was completed 3 times in a row
- When "Clear Memory" was performed

## 8. FAIL SAFE

None

## 9. ECM OPERATION AT DTC SETTING

Memorize the freeze frame data. (For test mode \$02)

# DIAGNOSTIC TROUBLE CODE (DTC) DETECTING CRITERIA

## GENERAL DESCRIPTION

### Z: DTC P0133 — O<sub>2</sub> SENSOR CIRCUIT SLOW RESPONSE (BANK 1 SENSOR 1)

#### 1. OUTLINE OF DIAGNOSIS

Detect the slow response of front oxygen (A/F) sensor.

Front oxygen (A/F) sensor cover has some ventilation holes for exhaust gas. Clogged ventilation holes are diagnosed.

When the holes are clogged, the A/F output variation becomes slow comparing with the actual A/F variation because oxygen which reaches the zirconia layer is insufficient. Therefore, if the cover has clogged holes, the rich to lean judgment in ECM is delayed when the change from rich to lean is caused.

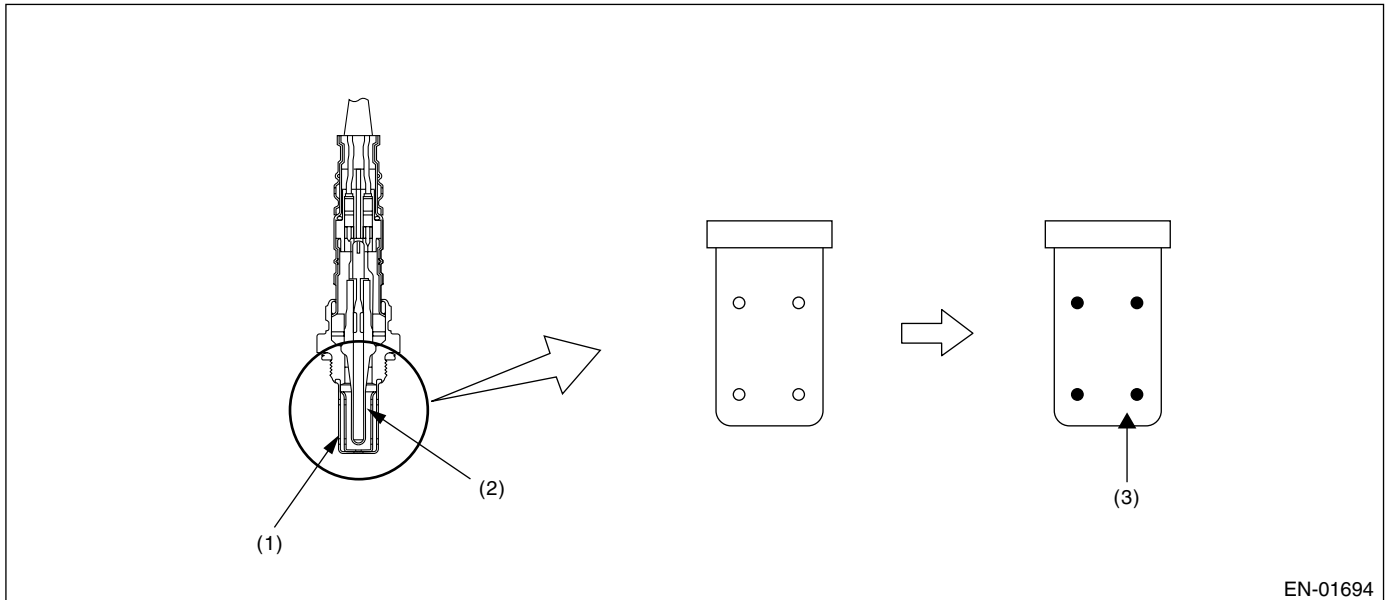

EN-01694

(1) Cover

(2) Zirconia

(3) Clogging



# DIAGNOSTIC TROUBLE CODE (DTC) DETECTING CRITERIA

GENERAL DESCRIPTION

When abnormal, the variation period from rich to lean is longer than when normal, as shown in the figure below.

When the condition is completed, the variation time from rich to lean and vice versa is calculated by varying the desired A/F value. Judge NG when the period is long.

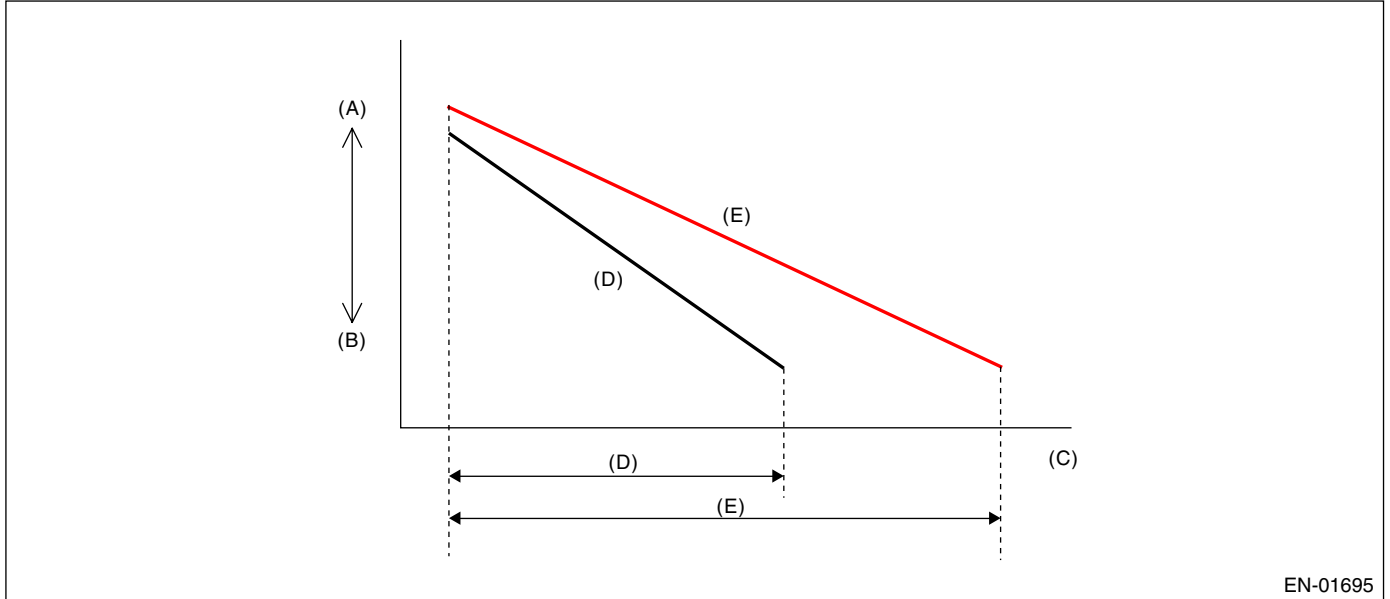

EN-01695

- (A) Rich
- (B) Lean
- (C) Time
- (D) Normal
- (E) Malfunction

## 2. COMPONENT DESCRIPTION

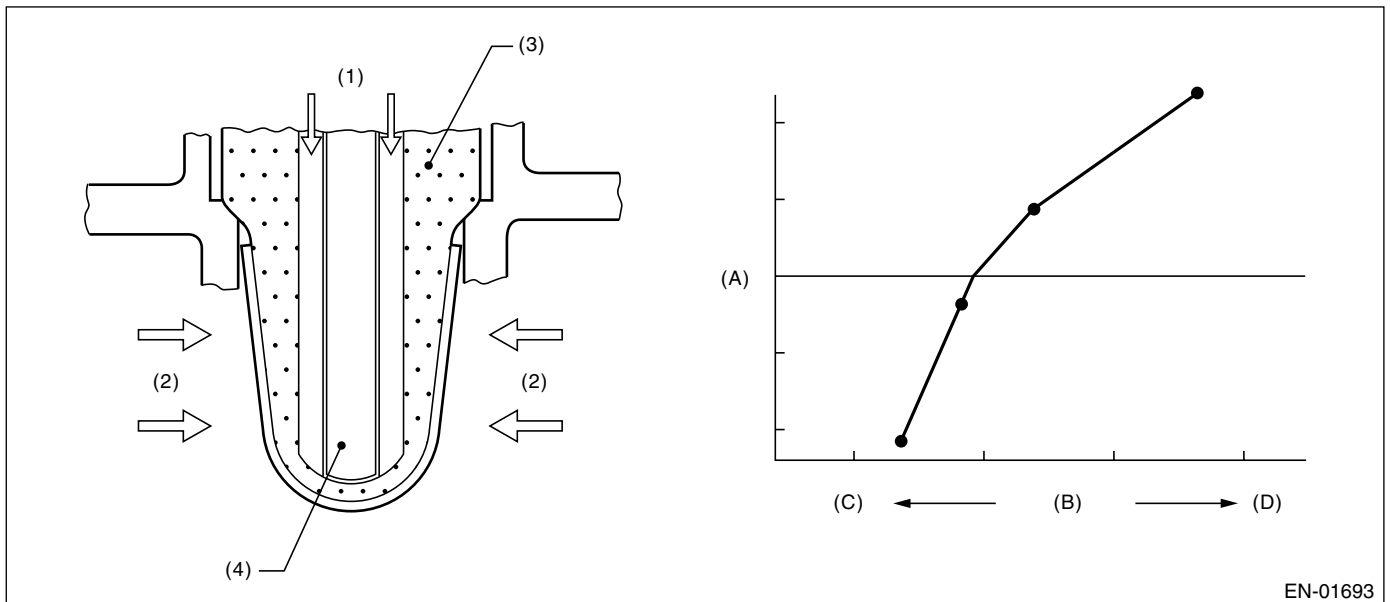

EN-01693

- (1) Atmosphere
- (2) Exhaust gas
- (3) ZrO<sub>2</sub>
- (4) Ceramic heater
- (A) Electromotive force
- (B) Air fuel ratio
- (C) Lean
- (D) Rich

# DIAGNOSTIC TROUBLE CODE (DTC) DETECTING CRITERIA

## GENERAL DESCRIPTION

### 3. ENABLE CONDITION

Secondary Parameter	Enable Condition
Closed loop control	In operation
Average lambda	0.703 ←→ 1.375
After starting the engine	225 seconds or more
Engine coolant temperature	≥ 75°C (167°F)
Injector pulse	1.792 ←→ 4.032 milliseconds
Engine speed	1800 ←→ 3000 rpm
Vehicle speed	≥ 76 km/h (47 MPH)
Atmospheric air pressure	≥ 76 kPa (568 mmHg, 22 inHg)
Throttle position change for 90 milliseconds	< 1.60°
Impedance of lambda sensor	10 ←→ 40 Ω
Misfire rate at engine 200 rev.	≤ 1.0%

### 4. GENERAL DRIVING CYCLE

Perform diagnosis constantly at greater than 76 km/h (47 MPH) just once in 225 seconds after starting the engine.

### 5. DIAGNOSTIC METHOD

When enable conditions are completed, measure the A/F sensor output A/F value variation period by changing air fuel ratio desired value to lean and rich. Judge NG when this period is long. Judge OK when this period is short.

Judge NG when the malfunction criteria below is completed. Judge OK when the malfunction criteria below is not completed.

#### Judgment Value

Malfunction Criteria	Threshold Value
Average time of 5 changes from rich to lean, and from lean to rich	> See Map 5
Response time when noise is detected is not used as data.	

#### Map 5

Engine Speed (Ne) (rpm)	1.75 — 2.25 (milliseconds)	2.25 — 2.75 (milliseconds)	2.75 — 3.19 (milliseconds)	3.19 — (milliseconds)
1800 ≤ Ne < 2100	1828	1825	1828	1828
2100 ≤ Ne < 2500	1167	976	976	911
2500 ≤ Ne < 3000	1095	976	976	911
3000 ≤ Ne	1095	872	825	825

**Time Needed for Diagnosis:** 2 to 12 seconds

**Malfunction Indicator Light Illumination:** Illuminates when malfunction occurs in 2 continuous driving cycles.

### 6. DTC CLEAR CONDITION

- When the OK idling cycle was completed 40 times in a row
- When "Clear Memory" was performed

### 7. MALFUNCTION INDICATOR LIGHT CLEAR CONDITION

- When the OK driving cycle was completed 3 times in a row
- When "Clear Memory" was performed

### 8. FAIL SAFE

None

# DIAGNOSTIC TROUBLE CODE (DTC) DETECTING CRITERIA

GENERAL DESCRIPTION

---

## 9. ECM OPERATION AT DTC SETTING

- Memorize the freeze frame data. (For test mode \$02)
- Memorize the diagnostic value and trouble standard value. (For test mode \$06)

# DIAGNOSTIC TROUBLE CODE (DTC) DETECTING CRITERIA

## GENERAL DESCRIPTION

### AA: DTC P0134 — O<sub>2</sub> SENSOR CIRCUIT NO ACTIVITY DETECTED (BANK 1 SENSOR 1) —

#### 1. OUTLINE OF DIAGNOSIS

Detect the open circuit of front oxygen (A/F) sensor.

Diagnosis is performed using A/F microcomputer, and communication is established between A/F microcomputer and main microcomputer. Judge NG when the data of open circuit NG is transmitted.

#### 2. COMPONENT DESCRIPTION

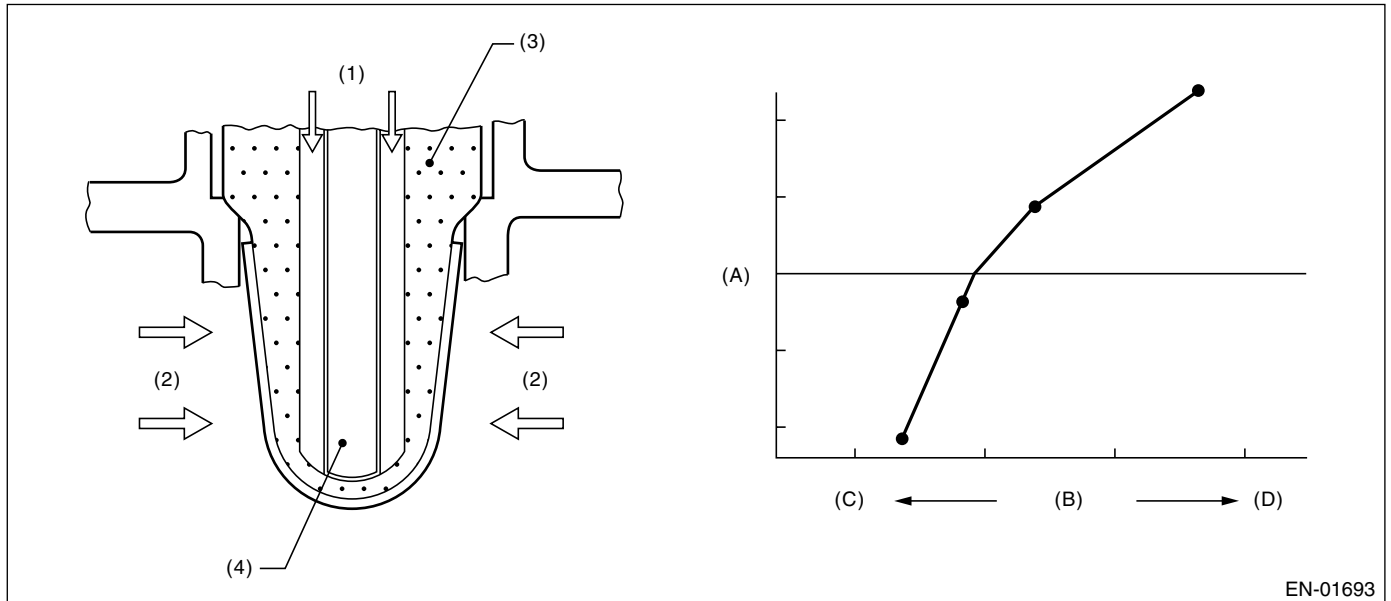

EN-01693

- |                      |                         |
|----------------------|-------------------------|
| (1) Atmosphere       | (A) Electromotive force |
| (2) Exhaust gas      | (B) Air fuel ratio      |
| (3) ZrO <sub>2</sub> | (C) Lean                |
| (4) Ceramic heater   | (D) Rich                |

#### 3. ENABLE CONDITION

Secondary Parameters	Enable Conditions
None	

#### 4. GENERAL DRIVING CYCLE

Terminate the diagnosis if the open circuit, low voltage short circuit or high voltage short circuit becomes NG once by performing diagnosis continuously.

#### 5. DIAGNOSTIC METHOD

Judge NG when the continuous time of completing all the malfunction criteria below becomes more than the time (5 seconds) needed for diagnosis.

##### Judgment Value

Malfunction Criteria	Threshold Value
Heater control	In operation
Resistance of front oxygen (A/F) sensor	> 500 Ω

**Time Needed for diagnosis:** 5 seconds

**Malfunction Indicator Light Illumination:** Illuminates as soon as malfunction occurs.

# DIAGNOSTIC TROUBLE CODE (DTC) DETECTING CRITERIA

GENERAL DESCRIPTION

---

## 6. DTC CLEAR CONDITION

- When the OK idling cycle was completed 40 times in a row
- When "Clear Memory" was performed

## 7. MALFUNCTION INDICATOR LIGHT CLEAR CONDITION

- When the OK driving cycle was completed 3 times in a row
- When "Clear Memory" was performed

## 8. FAIL SAFE

None

## 9. ECM OPERATION AT DTC SETTING

Memorize the freeze frame data. (For test mode \$02)

# DIAGNOSTIC TROUBLE CODE (DTC) DETECTING CRITERIA

## GENERAL DESCRIPTION

### AB:DTC P0137 — O<sub>2</sub> SENSOR CIRCUIT LOW VOLTAGE (BANK 1 SENSOR 2) —

#### 1. OUTLINE OF DIAGNOSIS

Detect the open or short circuit of rear oxygen sensor.  
Judge NG when out of the standard value.

#### 2. COMPONENT DESCRIPTION

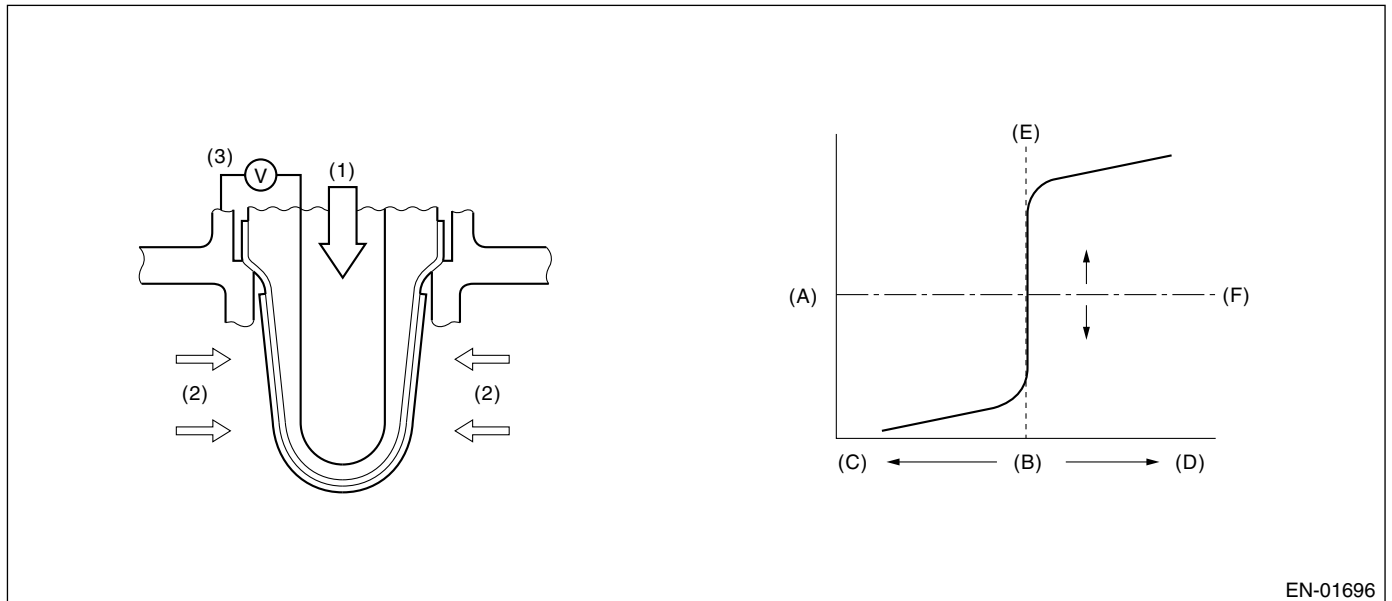

EN-01696

- (1) Atmosphere
- (2) Exhaust gas
- (3) Electromotive force

- (A) Electromotive force
- (B) Air fuel ratio
- (C) Lean

- (D) Rich
- (E) Theoretical air fuel ratio
- (F) Comparative voltage

#### 3. ENABLE CONDITION

Secondary Parameters	Enable Conditions
Closed loop control	In operation

#### 4. GENERAL DRIVING CYCLE

Perform the diagnosis only once during the closed loop.

# DIAGNOSTIC TROUBLE CODE (DTC) DETECTING CRITERIA

GENERAL DESCRIPTION

## 5. DIAGNOSTIC METHOD

Judge NG when the cumulative time of completing the malfunction criteria below becomes more than time needed for diagnosis.

### Judgment Value

Malfunction Criteria	Threshold Value
Maximum output voltage	< 490 mV
Coolant temperature	≥ 75°C (167°F)
Injector pulse	≥ 2.24 milliseconds
Engine speed	≥ 1500 rpm
2 seconds or more fuel shut-off in decel.	Experienced
Vehicle speed	≥ 32 km/h (20 MPH)
Engine misfire	None

**Time Needed for Diagnosis:** 200 seconds

**Malfunction Indicator Light Illumination:** Illuminates when malfunction occurs in 2 continuous driving cycles.

Judge OK and clear the NG when the malfunction criteria below are completed.

### Judgment Value

Malfunction Criteria	Threshold Value
maximum output voltage	≥ 490 mV

## 6. DTC CLEAR CONDITION

- When the OK driving cycle was completed 40 times in a row
- When "Clear Memory" was performed

## 7. MALFUNCTION INDICATOR LIGHT CLEAR CONDITION

- When the OK driving cycle was completed 3 times in a row
- When "Clear Memory" was performed

## 8. FAIL SAFE

None

## 9. ECM OPERATION AT DTC SETTING

- Memorize the freeze frame data. (For test mode \$02)
- Memorize the diagnostic value and trouble standard value. (For test mode \$06)

# DIAGNOSTIC TROUBLE CODE (DTC) DETECTING CRITERIA

## GENERAL DESCRIPTION

### AC:DTC P0138 — O<sub>2</sub> SENSOR CIRCUIT HIGH VOLTAGE (BANK 1 SENSOR 2) —

#### 1. OUTLINE OF DIAGNOSIS

Detect the open or short circuit of rear oxygen sensor.  
Judge NG when out of the standard value.

#### 2. COMPONENT DESCRIPTION

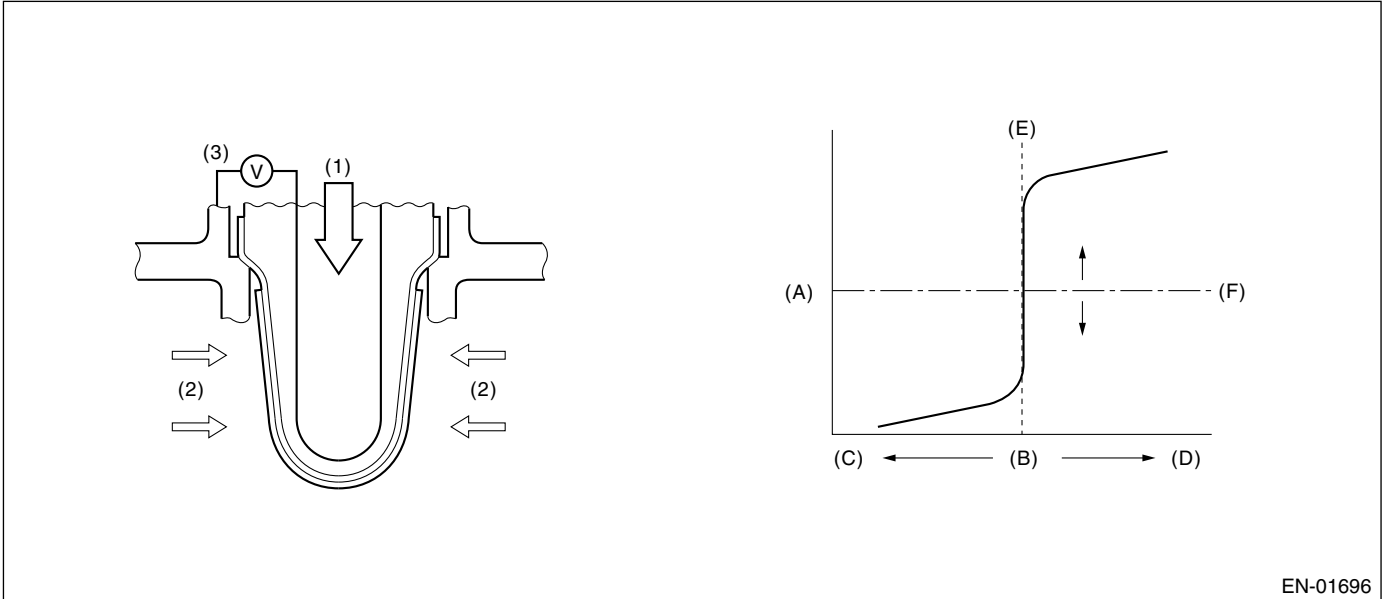

EN-01696

- (1) Atmosphere
- (2) Exhaust gas
- (3) Electromotive force

- (A) Electromotive force
- (B) Air fuel ratio
- (C) Lean

- (D) Rich
- (E) Theoretical air fuel ratio
- (F) Comparative voltage

#### 3. ENABLE CONDITION

Secondary Parameters	Enable Conditions
Closed loop control	In operation

#### 4. GENERAL DRIVING CYCLE

Perform the diagnosis only once during the closed loop.



# DIAGNOSTIC TROUBLE CODE (DTC) DETECTING CRITERIA

GENERAL DESCRIPTION

## 5. DIAGNOSTIC METHOD

### • Abnormality Judgment

Judge NG when the cumulative time of completing all the malfunction criteria below becomes more than time needed for diagnosis.

### • Judgment Value

Malfunction Criteria	Threshold Value
Minimum output voltage	> 250 mV
Coolant temperature	≥ 75°C (167°F)
Injector pulse	≥ 2.24 milliseconds
Engine speed	≥ 1500 rpm
2 seconds or more fuel shut-off in decel.	Experienced
Vehicle speed	≥ 32 km/h (20 MPH)
Engine misfire	None

**Time Needed for Diagnosis:** 200 seconds

**Malfunction Indicator Light Illumination:** Illuminates when malfunction occurs in 2 continuous driving cycles.

### • Normality Judgment

Judge OK and clear the NG when the malfunction criteria below are completed.

### • Judgment Value

Malfunction Criteria	Threshold Value
Minimum output voltage	≤ 250 mV

## 6. DTC CLEAR CONDITION

- When the OK driving cycle was completed 40 times in a row
- When "Clear Memory" was performed

## 7. MALFUNCTION INDICATOR LIGHT CLEAR CONDITION

- When the OK driving cycle was completed 3 times in a row
- When "Clear Memory" was performed

## 8. FAIL SAFE

None

## 9. ECM OPERATION AT DTC SETTING

- Memorize the freeze frame data. (For test mode \$02)
- Memorize the diagnostic value and trouble standard value. (For test mode \$06)

# DIAGNOSTIC TROUBLE CODE (DTC) DETECTING CRITERIA

## GENERAL DESCRIPTION

### AD:DTC P0139 — O<sub>2</sub> SENSOR CIRCUIT SLOW RESPONSE (BANK 1 SENSOR 2)

#### 1. OUTLINE OF DIAGNOSIS

Detect the slow response of rear oxygen sensor.

Calculate the response time of the output change of the rear oxygen sensor when the A/F ratio changes from rich to lean. And carry out the diagnosis comparing the calculated response time with the threshold value.

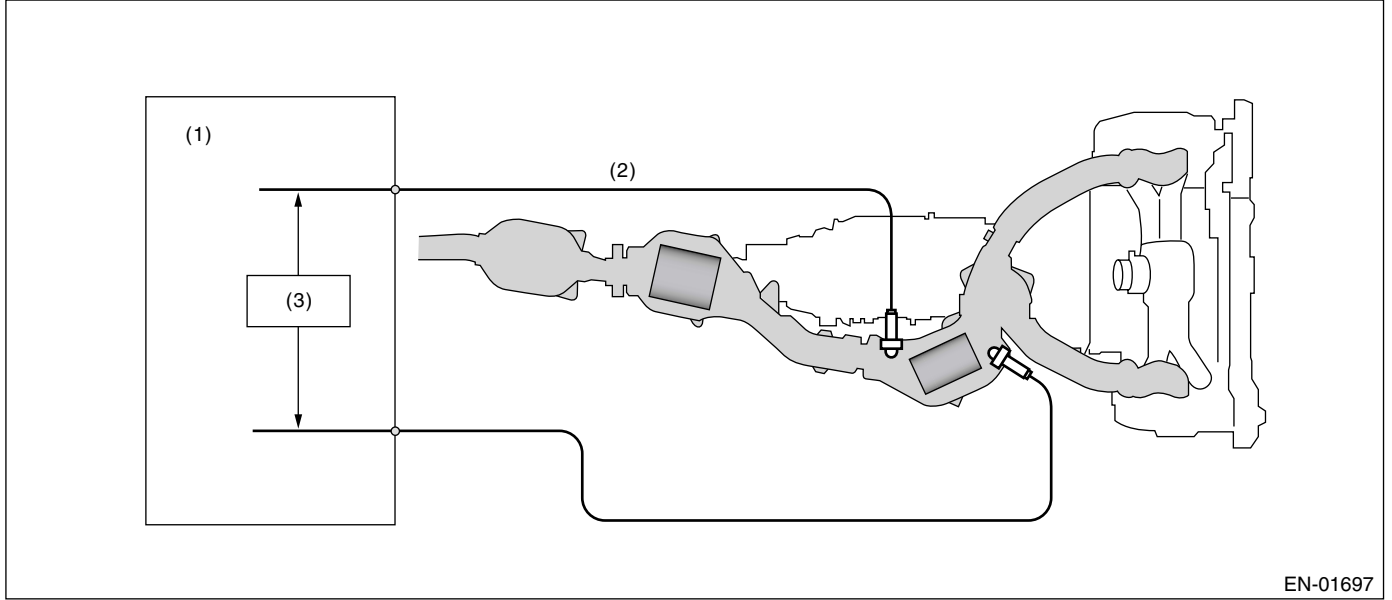

EN-01697

(1) Engine control module (ECM)

(2) Rear oxygen sensor

(3) Diagnosis circuit

#### 2. COMPONENT DESCRIPTION

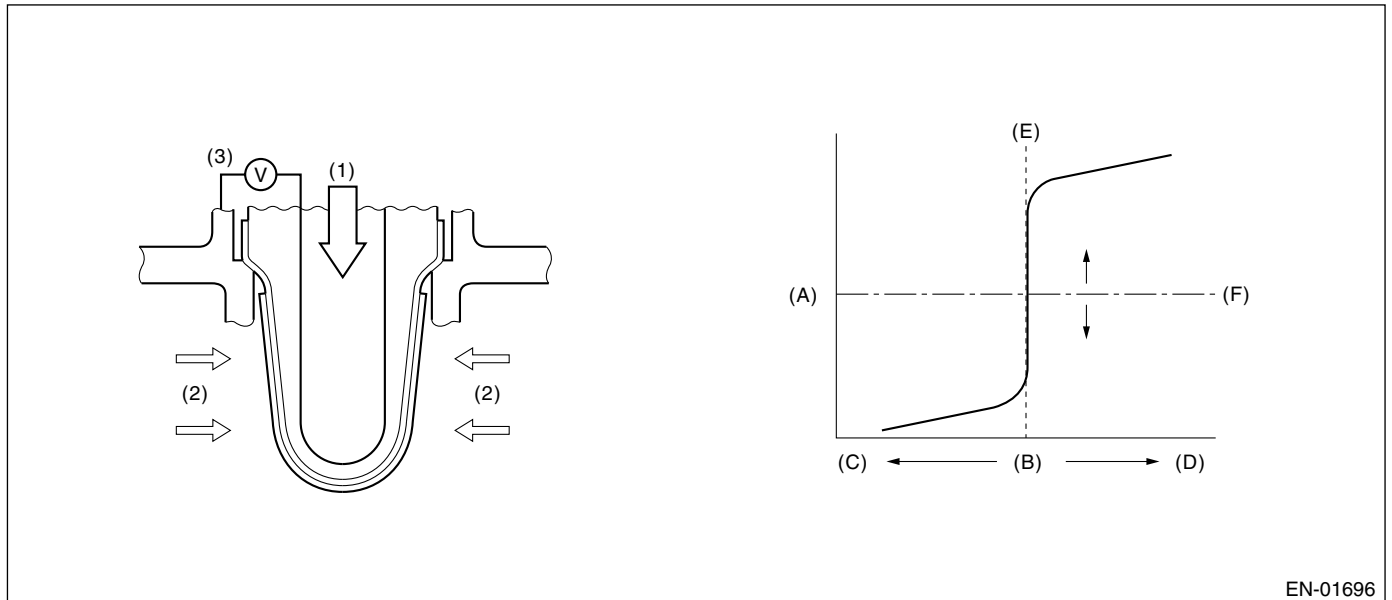

EN-01696

(1) Atmosphere

(2) Exhaust gas

(3) Electromotive force

(A) Electromotive force

(B) Air fuel ratio

(C) Lean

(D) Rich

(E) Theoretical air fuel ratio

(F) Comparative voltage

# DIAGNOSTIC TROUBLE CODE (DTC) DETECTING CRITERIA

GENERAL DESCRIPTION

## 3. ENABLE CONDITION

Secondary Parameters	Enable Conditions
Closed loop control with rear oxygen sensor	In operation

## 4. GENERAL DRIVING CYCLE

Perform the diagnosis only once during fuel cut at deceleration from the rapid acceleration. (Pay attention to oxygen sensor voltage when deciding the deceleration timing to calculate the diagnostic value.)

## 5. DIAGNOSTIC METHOD

When the rear oxygen sensor output voltage changes from 0.5 V (rich) to 0.15 V (lean), carry out calculation regarding the response time of the output change from 0.45 V to 0.2 V as diagnostic value. When the rear oxygen sensor output voltage does not change from 0.5 V to 0.15 V, do not carry out calculation even if the output changes from 0.45 V to 0.2 V.

### • Abnormality Judgment

Judge NG when the rear oxygen sensor output change response time (diagnostic value) exceeds the threshold value.

Response time > 2 seconds (threshold value) → Abnormal

Judge NG when all of the malfunction criteria below is completed.

### • Judgment Value

Malfunction Criteria	Threshold Value
Shortest time change from rich (450 mV oxygen output) to lean (200 mV) if voltage reduces from 500 mV to 150 mV	≥ 0.53 seconds
2 seconds or more fuel shut-off in decel. After fuel shut-off	Experienced 2 seconds or more

**Time Needed for Diagnosis:** 4 seconds

**Malfunction Indicator Light Illumination:** Illuminates when malfunction occurs in 2 continuous driving cycles.

### • Normality Judgment

Judge OK when the rear oxygen sensor output change response time (diagnostic value) is below the threshold value.

Response time ≤ 2 seconds (threshold value) → Normal

Judge NG when the malfunction criteria below is completed.

### • Judgment Value

Malfunction Criteria	Threshold Value
Shortest time change	≤ 0.53 seconds

### NOTE:

Response time is calculated during the deceleration fuel cut in case of abnormal judgment. However, in order to make a normal judgment quickly, diagnosis is performed without deceleration fuel cut.

# DIAGNOSTIC TROUBLE CODE (DTC) DETECTING CRITERIA

## GENERAL DESCRIPTION

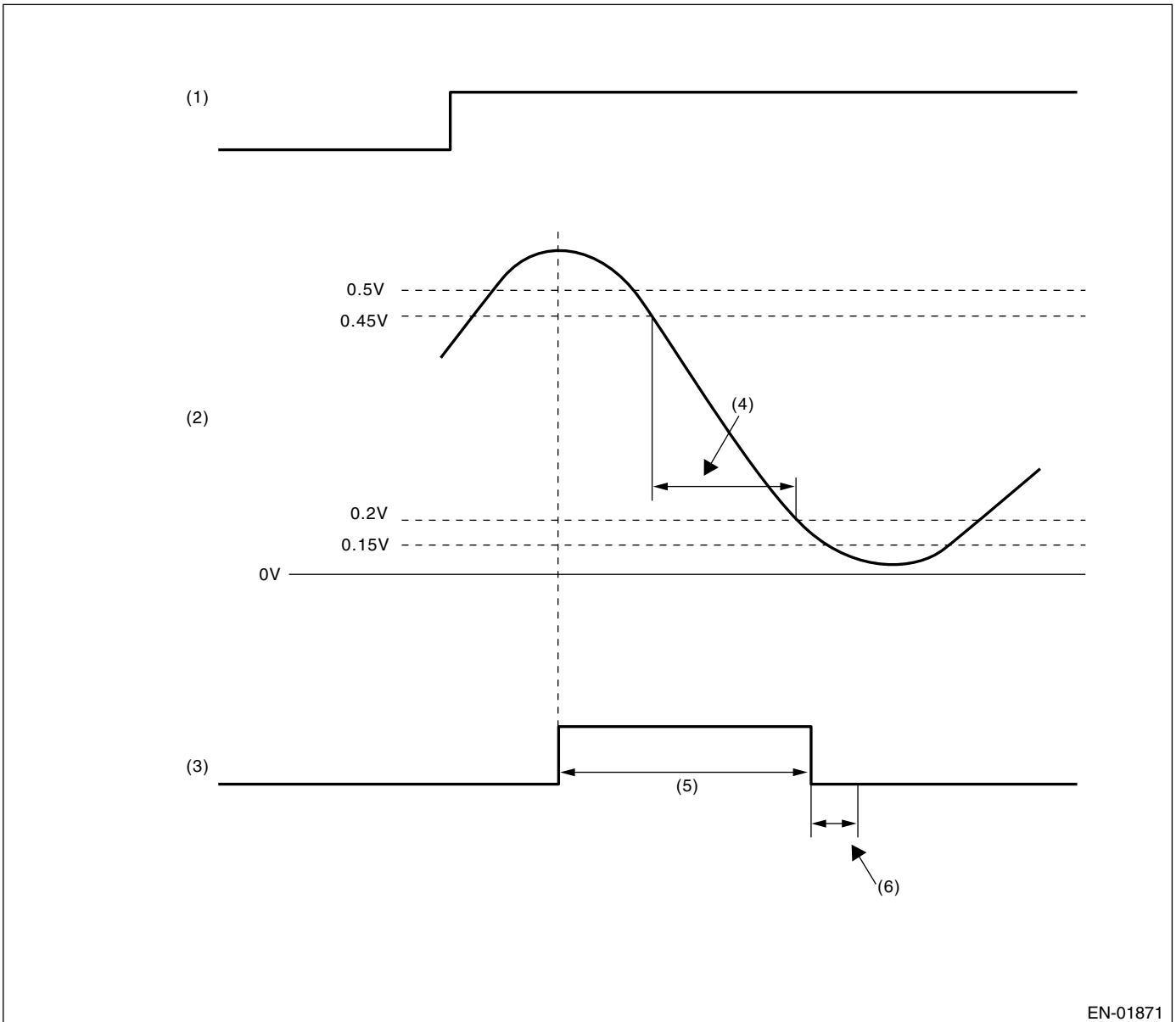

- (1) Diagnosis execution condition
- (2) Rear oxygen sensor (V)
- (3) Fuel cut on deceleration

- (4) Measure the response time
- (5) More than 2 seconds

- (6) Execute the malfunction judgment in 2 seconds from the recovery of fuel cut on deceleration.

## 6. DTC CLEAR CONDITION

- When the OK idling cycle was completed 40 times in a row
- When "Clear Memory" was performed

## 7. MALFUNCTION INDICATOR LIGHT CLEAR CONDITION

- When the OK driving cycle was completed 3 times in a row
- When "Clear Memory" was performed

## 8. FAIL SAFE

None

# DIAGNOSTIC TROUBLE CODE (DTC) DETECTING CRITERIA

GENERAL DESCRIPTION

---

## 9. ECM OPERATION AT DTC SETTING

- Memorize the freeze frame data. (For test mode \$02)
- Memorize the diagnostic value and trouble standard value. (For test mode \$06)

# DIAGNOSTIC TROUBLE CODE (DTC) DETECTING CRITERIA

## GENERAL DESCRIPTION

### AE:DTC P0171 — SYSTEM TOO LEAN (BANK 1) —

#### 1. OUTLINE OF DIAGNOSIS

Detect the malfunction of fuel system by the amount of main feedback control.

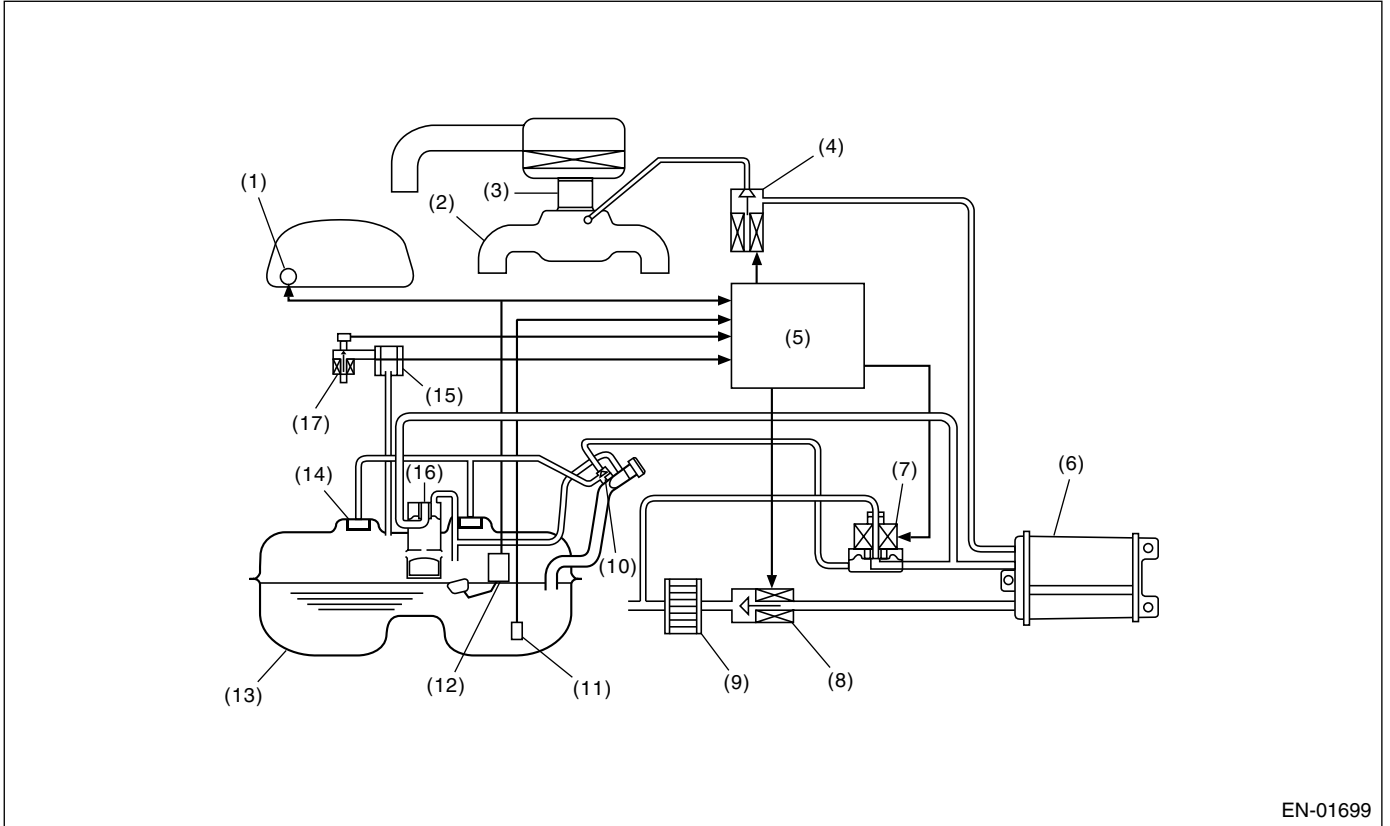

EN-01699

- |                                  |                                     |   |
|----------------------------------|-------------------------------------|---|
| (1) Fuel meter                   | (7) Pressure control solenoid valve | (13) Fuel tank                              |
| (2) Intake manifold              | (8) Drain valve                     | (14) Fuel cut valve                         |
| (3) Throttle body                | (9) Drain filter                    | (15) Fuel tank pressure sensor              |
| (4) Purge control solenoid valve | (10) Shut-off valve                 | (16) Vent valve                             |
| (5) Engine control module (ECM)  | (11) Fuel temperature sensor        | (17) Tank pressure switching solenoid valve |
| (6) Canister                     | (12) Fuel level sensor              |   |

Fuel system is diagnosed by comparing the target air fuel ratio calculated by ECM with the actual air fuel ratio measured by sensor.

#### 2. ENABLE CONDITION

Secondary Parameters	Enable Conditions
Fuel learning system	In operation
Engine coolant temperature	75 ↔ 110°C (167 ↔ 230°F)
Intake manifold pressure change during 50 msec	≤ 1.95 kPa (14.6 mmHg, 0.575 inHg)
Learning value of EVAP conc. during purge	≤ 1.0
Cumulative time of canister purge after engine start	20 seconds or more
Continuous period after canister purge starting	10 seconds or more
Intake air pressure	≥ Map 3

# DIAGNOSTIC TROUBLE CODE (DTC) DETECTING CRITERIA

GENERAL DESCRIPTION

## Map 3

Engine speed (rpm)	idle	800	1200	1600	2000	2400	2800	3200	3600	4000	4400
Pressure kPa (mmHg, inHg)	ha	24.0 (180, 7.09)	27.2 (204, 8.03)	27.2 (204, 8.03)	28.3 (212, 8.35)	29.9 (224, 8.82)	32.5 (244, 9.61)	34.1 (256, 10.08)	34.1 (256, 10.08)	33.1 (248, 9.76)	33.1 (248, 9.76)

## 3. GENERAL DRIVING CYCLE

Perform the serial diagnoses with idling or a constant vehicle speed after engine starting.

## 4. DIAGNOSTIC METHOD

Judge that the malfunction occurred in fuel system when the malfunction criteria are completed for 50 seconds or more by comparing the diagnostic value (fsobd) with threshold value.

### Judgment Value

Malfunction Criteria	Threshold Value
fsobd = aflmd + lambda + kblrc aflmd = measured lambda lambda = short term fuel trim kblrc = long term fuel trim	≥ fsobdL1 See Map 2 fsobdL1 = lean side threshold value of fsobd

### Map 2: Threshold value for fuel system malfunction criteria

Amount of air (g (oz)/s)	0 (0)	3.2 (0.113)	6.4 (0.226)	9.6 (0.339)	12.8 (0.451)	16 (0.564)	19.2 (0.677)
fsobdL1 (%)	40	40	33.2	26.5	26.5	26.5	26.5

**Time Needed for Diagnosis:** 10 seconds × 5 times

**Malfunction Indicator Light Illumination:** 2 continuous driving cycles.

Judge OK when the malfunction criteria below are completed for 10 seconds or more.

### Judgment Value

Malfunction Criteria	Threshold Value
fsobd = aflmd + lambda + kblrc	< 19%

## 5. DTC CLEAR CONDITION

- When the OK idling cycle is completed 40 times in a row
- When "Clear Memory" was performed

## 6. MALFUNCTION INDICATOR LIGHT CLEAR CONDITION

- When diagnosed OK with the similar driving for 3 driving cycles in a row
- When "Clear Memory" was performed

## 7. FAIL SAFE

None

## 8. ECM OPERATION AT DTC SETTING

Memorize the freeze frame data. (For test mode \$02)

# DIAGNOSTIC TROUBLE CODE (DTC) DETECTING CRITERIA

## GENERAL DESCRIPTION

### AF:DTC P0172 — SYSTEM TOO RICH (BANK 1) —

#### 1. OUTLINE OF DIAGNOSIS

Detect the malfunction of fuel system by the amount of main feedback control.

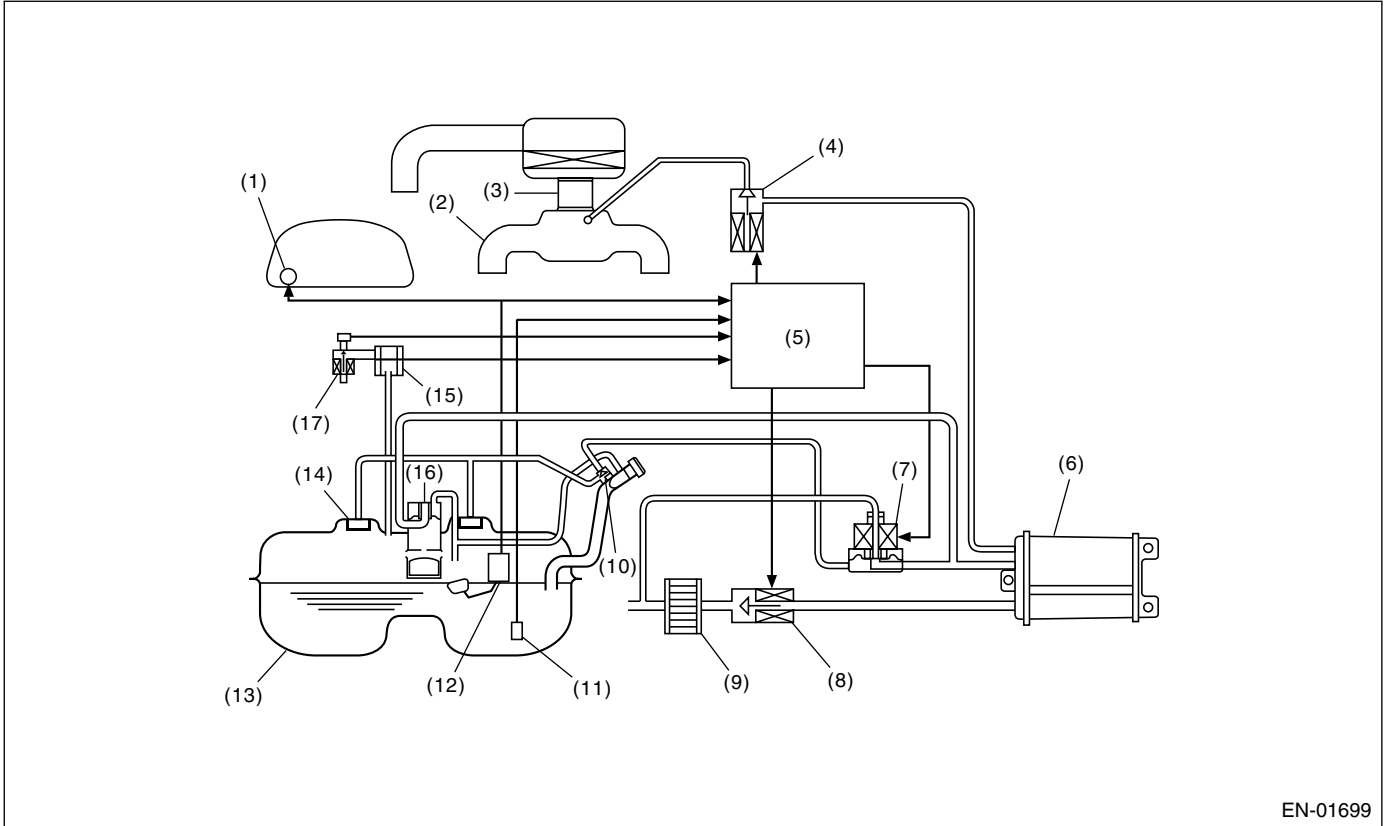

EN-01699

- |                                  |                                     |   |
|----------------------------------|-------------------------------------|---|
| (1) Fuel meter                   | (7) Pressure control solenoid valve | (13) Fuel tank                              |
| (2) Intake manifold              | (8) Drain valve                     | (14) Fuel cut valve                         |
| (3) Throttle body                | (9) Drain filter                    | (15) Fuel tank pressure sensor              |
| (4) Purge control solenoid valve | (10) Shut-off valve                 | (16) Vent valve                             |
| (5) Engine control module (ECM)  | (11) Fuel temperature sensor        | (17) Tank pressure switching solenoid valve |
| (6) Canister                     | (12) Fuel level sensor              |   |

Fuel system is diagnosed by comparing the target air fuel ratio calculated by ECM with the actual air fuel ratio measured by sensor.

#### 2. ENABLE CONDITION

Secondary Parameters	Enable Conditions
Fuel learning system	In operation
Engine coolant temperature	75 ↔ 110°C (167 ↔ 230°F)
Intake manifold pressure change during 50 msec	≤ 1.95 kPa (14.6 mmHg, 0.575 inHg)
Learning value of EVAP conc. during purge	≤ 1.0
Cumulative time of canister purge after engine start	20 seconds or more
Continuous period after canister purge starting	10 seconds or more



# DIAGNOSTIC TROUBLE CODE (DTC) DETECTING CRITERIA

GENERAL DESCRIPTION

## Map 3

Engine speed (rpm)	idle	800	1200	1600	2000	2400	2800	3200	3600	4000	4400
Pressure kPa (mmHg, inHg)	ha	24.0 (180, 7.09)	27.2 (204, 8.03)	27.2 (204, 8.03)	28.3 (212, 8.35)	29.9 (224, 8.82)	32.5 (244, 9.61)	34.1 (256, 10.08)	34.1 (256, 10.08)	33.1 (248, 9.76)	33.1 (248, 9.76)

## 3. GENERAL DRIVING CYCLE

Perform the serial diagnoses.

## 4. DIAGNOSTIC METHOD

Judge that the malfunction occurred in fuel system when the malfunction criteria are completed for 50 seconds or more by comparing the diagnostic value (fsobd) with threshold value.

### Judgment Value

Malfunction Criteria	Threshold Value
fsobd = aflmd + lambda + kblrc aflmd = measured lambda lambda = short term fuel trim kblrc = long term fuel trim	≤ fsobdR1 See Map 2 fsobdR1 = rich side threshold value of fsobd

### Map 2: Threshold value for fuel system malfunction criteria

Amount of air (g/s)	0 (0)	3.2 (0.113)	6.4 (0.226)	9.6 (0.339)	12.8 (0.451)	16 (0.564)	19.2 (0.677)
fsobdR1 (%)	-45	-45	-36	-26.5	-26.5	-26.5	-26.5

**Time Needed for Diagnosis:** 10 seconds × 5 times

**Malfunction Indicator Light Illumination:** 2 continuous driving cycles.

Judge OK when the malfunction criteria below are completed for 10 seconds or more.

### Judgment Value

Malfunction Criteria	Threshold Value
fsobd = aflmd + lambda + kblrc	≥ -20%

## 5. DTC CLEAR CONDITION

- When the OK idling cycle is completed 40 times in a row
- When "Clear Memory" was performed

## 6. MALFUNCTION INDICATOR LIGHT CLEAR CONDITION

- When diagnosed OK with the similar driving for 3 driving cycles in a row
- When "Clear Memory" was performed

## 7. FAIL SAFE

None

## 8. ECM OPERATION AT DTC SETTING

Memorize the freeze frame data. (For test mode \$02)

# DIAGNOSTIC TROUBLE CODE (DTC) DETECTING CRITERIA

## GENERAL DESCRIPTION

### AG:DTC P0181 — FUEL TEMPERATURE SENSOR “A” CIRCUIT RANGE/PERFORMANCE —

#### 1. OUTLINE OF DIAGNOSIS

Detect the malfunction of fuel temperature sensor output property.  
Diagnosis is performed in two methods; namely, drift diagnosis and stuck diagnosis.

#### 2. COMPONENT DESCRIPTION

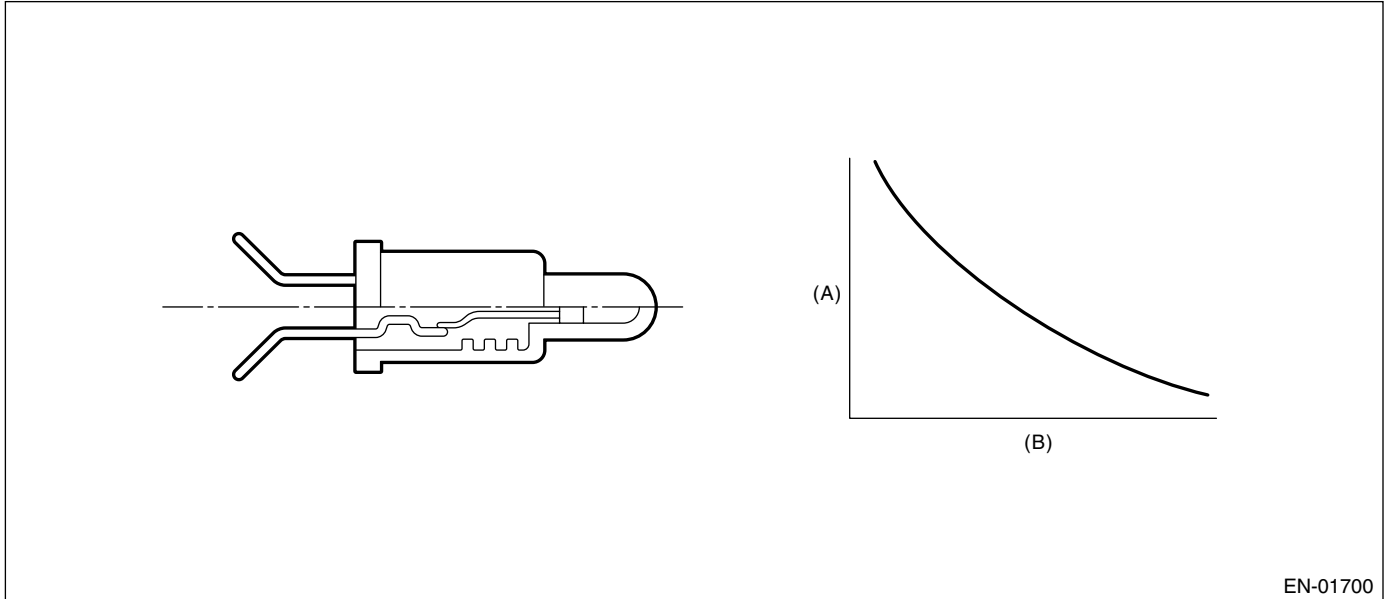

EN-01700

(A) Resistance value (Ω)

(B) Fuel temperature °C (°F)

#### • Drift Diagnosis

Normally fuel temperature is lower than engine coolant temperature. When the fuel temperature becomes higher than the engine coolant temperature, the range is considered to be shifted, and NG judgment is done.

#### 3. ENABLE CONDITION

Secondary Parameters	Enable Conditions
Fuel level	≥ 10 l (2.6 US gal, 2.2 Imp gal)
After engine starting	20 seconds or more
Engine coolant temperature difference from engine start	> -8°C (18°F)

#### 4. GENERAL DRIVING CYCLE

Perform the diagnosis continuously when the engine coolant temperature increases more than -8 degrees (18 degrees of Fahrenheit) from the temperature of engine starting in 20 seconds after starting the engine.

# DIAGNOSTIC TROUBLE CODE (DTC) DETECTING CRITERIA

GENERAL DESCRIPTION

## 5. DIAGNOSTIC METHOD

Judge NG when the continuous time until completing the malfunction criteria below becomes more than the time (120 seconds) needed for diagnosis. Also, judge OK when the malfunction criteria below is not completed. And then, clear the NG.

### Judgment Value

Malfunction Criteria	Threshold Value
Fuel temperature-engine coolant temperature	$\geq 10^{\circ}\text{C}$ (50°F)

**Time Needed for Diagnosis:** 120 seconds

**Malfunction Indicator Light Illumination:** Illuminates when malfunction occurs in 2 continuous driving cycles.

Stuck Diagnosis

If the fuel temperature which must increase along with engine idling does not increase, the engine is considered to be stuck and NG judgment is done.

## 6. ENABLE CONDITION

Secondary Parameters	Enable Conditions
After engine starting	20 seconds or more

## 7. GENERAL DRIVING CYCLE

Perform the diagnosis continuously in 20 seconds and more after starting the engine.

## 8. DIAGNOSTIC METHOD

### • Abnormality Judgment

Judge NG when all of the malfunction criteria below is completed.

Malfunction Criteria	Threshold Value
Accumulated amount of intake air	$\geq 550$ kg (1213 lb)
Fuel temperature difference between max and min	$< 3^{\circ}\text{C}$ (37°F)

### • Normality Judgment

Judge OK and clear the NG when the malfunction criteria below are completed.

Malfunction Criteria	Threshold Value
Fuel temperature difference between max. and min.	$\geq 3^{\circ}\text{C}$ (37°F)

**Time Needed for Diagnosis:** Not fixed

**Malfunction Indicator Light Illumination:** Illuminates when malfunction occurs in 2 continuous driving cycles.

## 9. DTC CLEAR CONDITION

- When the OK idling was completed 40 times in a row
- When "Clear Memory" was performed

## 10. MALFUNCTION INDICATOR LIGHT CLEAR CONDITION

- When the OK driving cycle was completed 3 times in a row
- When "Clear Memory" was performed

## 11. FAIL SAFE

Fix the fuel temperature at 40°C (104°F).

## 12. ECM OPERATION AT DTC SETTING

Memorize the freeze frame data. (For test mode \$02)

# DIAGNOSTIC TROUBLE CODE (DTC) DETECTING CRITERIA

## GENERAL DESCRIPTION

### AH:DTC P0182 — FUEL TEMPERATURE SENSOR “A” CIRCUIT LOW INPUT —

#### 1. OUTLINE OF DIAGNOSIS

Detect the open or short circuit of fuel temperature sensor.  
Judge NG when out of the standard value.

#### 2. COMPONENT DESCRIPTION

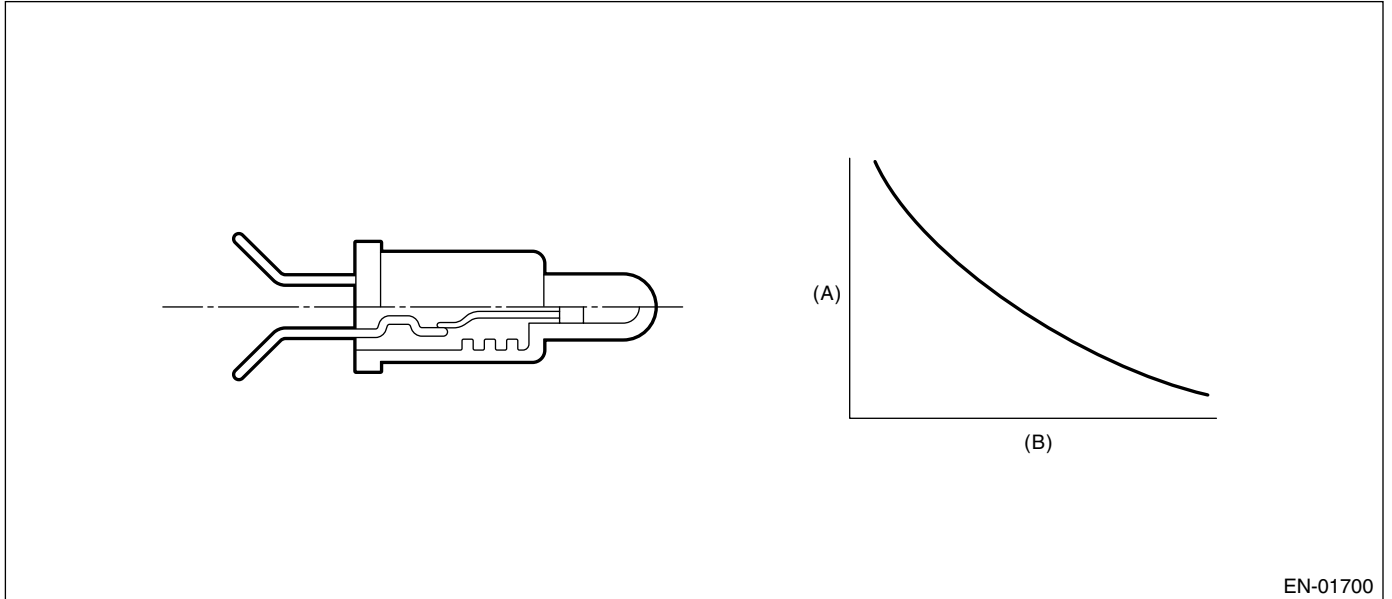

EN-01700

(A) Resistance value (Ω)

(B) Fuel temperature °C (°F)

#### 3. ENABLE CONDITION

Secondary Parameters	Enable Conditions
None	

#### 4. GENERAL DRIVING CYCLE

Always perform the diagnosis continuously.

#### 5. DIAGNOSTIC METHOD

Judge NG when the continuous time of completing the malfunction criteria below becomes more than the time (2.5 seconds) needed for diagnosis. Judge OK and clear NG when the malfunction criteria below are not completed.

##### Judgment Value

Malfunction Criteria	Threshold Value
Output voltage	$\leq 0.1$ V

**Time Needed for Diagnosis:** 2.5 seconds

**Malfunction Indicator Light Illumination:** Illuminates as soon as malfunction occurs.

#### 6. DTC CLEAR CONDITION

- When the OK idling cycle was completed 40 times in a row
- When “Clear Memory” was performed

#### 7. MALFUNCTION INDICATOR LIGHT CLEAR CONDITION

- When the OK driving cycle was completed 3 times in a row
- When “Clear Memory” was performed

# DIAGNOSTIC TROUBLE CODE (DTC) DETECTING CRITERIA

GENERAL DESCRIPTION

---

## 8. FAIL SAFE

Fix the fuel temperature for control at 40°C (104°F).

## 9. ECM OPERATION AT DTC SETTING

Memorize the freeze frame data. (For test mode \$02)

# DIAGNOSTIC TROUBLE CODE (DTC) DETECTING CRITERIA

## GENERAL DESCRIPTION

### AI: DTC P0183 — FUEL TEMPERATURE SENSOR “A” CIRCUIT HIGH INPUT —

#### 1. OUTLINE OF DIAGNOSIS

Detect the open or short circuit of fuel temperature sensor.  
Judge NG when out of the standard value.

#### 2. COMPONENT DESCRIPTION

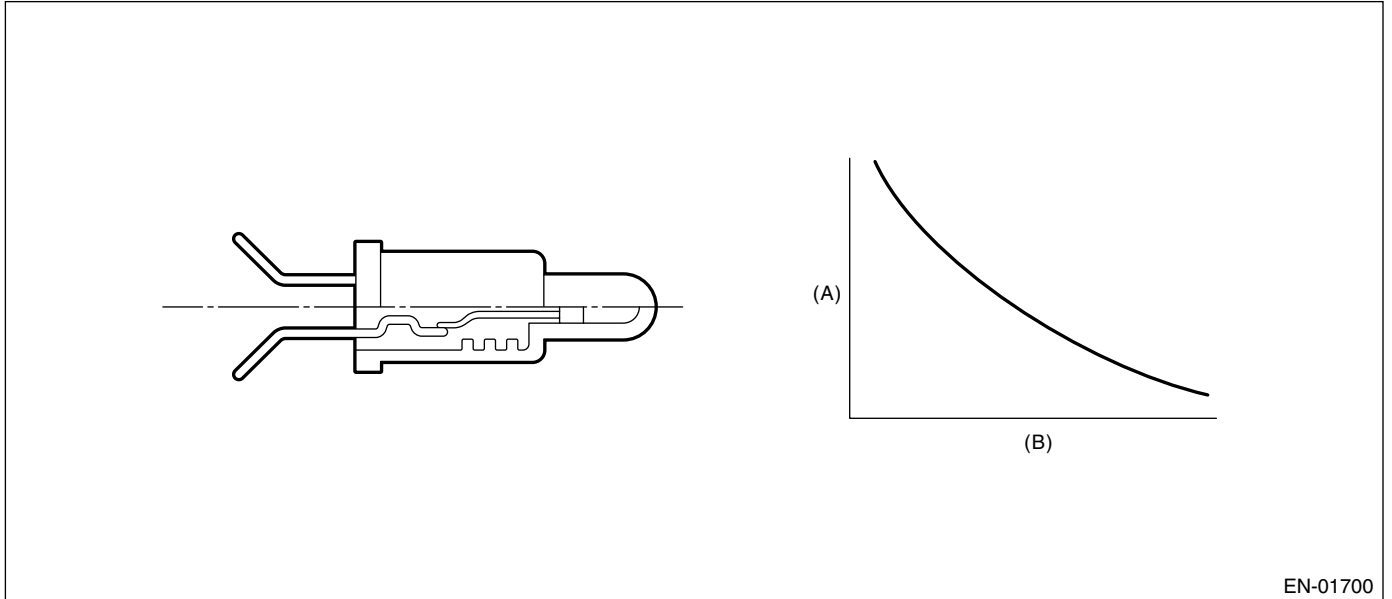

EN-01700

(A) Resistance value ( $\Omega$ )

(B) Fuel temperature  $^{\circ}\text{C}$  ( $^{\circ}\text{F}$ )

#### 3. ENABLE CONDITION

Secondary Parameters	Enable Conditions
None	

#### 4. GENERAL DRIVING CYCLE

Always perform the diagnosis continuously.

#### 5. DIAGNOSTIC METHOD

Judge NG when the cumulative time of completing the malfunction criteria below becomes more than time (2.5 seconds) needed for diagnosis. Judge OK when the malfunction criteria below are not completed.

##### Judgment Value

Malfunction Criteria	Threshold Value
Output voltage	$\geq 4.85 \text{ V}$

**Time Needed for Diagnosis:** 2.5 seconds

**Malfunction Indicator Light Illumination:** Illuminates as soon as malfunction occurs.

#### 6. DTC CLEAR CONDITION

- When the OK idling cycle was completed 40 times in a row
- When “Clear Memory” was performed

#### 7. MALFUNCTION INDICATOR LIGHT CLEAR CONDITION

- When the OK driving cycle was completed 3 times in a row
- When “Clear Memory” was performed

#### 8. FAIL SAFE

Fix the fuel temperature for control at  $40^{\circ}\text{C}$  ( $104^{\circ}\text{F}$ ).

# DIAGNOSTIC TROUBLE CODE (DTC) DETECTING CRITERIA

GENERAL DESCRIPTION

---

## 9. ECM OPERATION AT DTC SETTING

Memorize the freeze frame data. (For test mode \$02)

# DIAGNOSTIC TROUBLE CODE (DTC) DETECTING CRITERIA

## GENERAL DESCRIPTION

### AJ:DTC P0301 — CYLINDER 1 MISFIRE DETECTED —

#### 1. OUTLINE OF DIAGNOSIS

Detect the presence of misfire occurrence.

Monitoring Misfire which influences exhaust deterioration (1.5 times of FTP) and catalyst damage is made obligatory by the law. Misfire affecting these two has three patterns below.

- Intermittent misfire (Different cylinders misfire intermittently.): FTP 1.5 times misfire
- Every time misfire (The same cylinder misfires every time.): Catalyst damage misfire, FTP 1.5 times misfire
- Opposed misfire (Dual ignition equipped model as #1, #2 simultaneously ignite. NA model only.): Catalyst damage misfire, FTP 1.5 times misfire

The following detecting methods are adopted for these detection.

- (1) Intermittent misfire: FTP 1.5 times misfire
  - 180° Interval Difference Method (3,550 rpm or less)
  - 720° Interval Difference Method (2,950 rpm or less)
- (2) Every time misfire: Catalyst damage misfire, FTP 1.5 times misfire
  - 180° Interval Difference Method (3,550 rpm or less)
  - Pattern Recognition Method (2,950 rpm or more)
- (3) Opposed misfire: Catalyst damage misfire, FTP 1.5 times misfire
  - 180° Interval Difference Method (3,550 rpm or less)
  - Pattern Recognition Method (2,950 rpm or more)

#### 2. ENABLE CONDITION

Secondary Parameters	Enable Conditions
Injector pulse	≥ 1.00 milliseconds
Engine speed	450 — 6200 rpm
Fuel shut-off function	Not in operation
Fuel parameter determination	Not as extremely low volatility
Engine speed change	≥ Misfire level × -4.00
After fuel shut-off finished	15 revs. or more
(Weighted avg. value / given amount) of intake air -1.0	-0.5 ↔ 1.9
Fuel level	≥ 9 ℓ (2.4 US gal, 2.0 Imp gal)
Crankshaft position learning	Complete
Intake manifold pressure	> Value from Map 4
The change in torque during shifting	Not in operation
Throttle position change during 30 milliseconds	-20° ↔ 20°
Engine speed (Misfire detection by oxygen sensor)	> 4600 rpm

#### Map 4

rpm	0	400	800	1200	1600	2000	2400	2800
MT (V. Speed < 64 km/h (40 MPH))	21.9 (164, 6.46)	21.9 (164, 6.46)	21.9 (164, 6.46)	19.2 (144, 5.67)	18.7 (140, 5.51)	19.2 (144, 5.67)	18.7 (140, 5.51)	19.7 (148, 5.83)
(V. Speed ≥ 64 km/h (40 MPH)) kPa (mmHg, inHg)	21.9 (164, 6.46)	21.9 (164, 6.46)	21.9 (164, 6.46)	25.6 (192, 7.56)	25.1 (188, 7.40)	25.6 (192, 7.56)	24.5 (184, 7.24)	31.5 (236, 9.29)
AT kPa (mmHg, inHg)	22.9 (172, 6.77)	22.9 (172, 6.77)	22.9 (172, 6.77)	20.3 (152, 5.98)	20.3 (152, 5.98)	21.3 (160, 6.30)	20.3 (152, 5.98)	21.9 (164, 6.46)



# DIAGNOSTIC TROUBLE CODE (DTC) DETECTING CRITERIA

GENERAL DESCRIPTION

rpm	3200	3600	4000	4400	4800	5200	5600	6000
MT (V. Speed < 64 km/h (40 MPH))	22.9 (172, 6.77)	25.1 (188, 7.40)	28.3 (212, 8.35)	31.5 (236, 9.29)	34.7 (260, 10.24)	38.4 (288, 11.34)	41.6 (312, 12.28)	44.8 (336, 13.23)
(V. Speed ≥ 64 km/h (40 MPH)) kPa (mmHg, inHg)	32.5 (244, 9.61)	31.5 (236, 9.59)	31.5 (236, 9.59)	31.5 (236, 9.59)	34.7 (260, 10.24)	38.4 (288, 11.34)	41.6 (312, 12.28)	44.8 (336, 13.23)
AT kPa (mmHg, inHg)	25.1 (188, 7.40)	28.8 (216, 8.50)	32.0 (240, 9.45)	35.2 (264, 10.39)	37.9 (284, 11.18)	41.1 (308, 12.13)	44.3 (332, 13.07)	47.5 (356, 14.02)

### 3. GENERAL DRIVING CYCLE

If the condition matched, detecting misfire is possible in the engine speed of idling to high revolution.

### 4. DIAGNOSTIC METHOD

When the misfire occurred, the engine speed is decreased and the crankshaft position speed will change. Calculate the interval difference value (diagnostic value) from crankshaft position speed, and judge whether the misfire occurs or not comparing the calculated result with judgment value.

- |   |   |  |
|---|---|--|
| Calculate the diagnostic value (from crankshaft position speed) | → Misfire detection every single ignition (Compare diagnostic value with judgment value) <ul style="list-style-type: none"> <li>• 180° Interval Difference Method</li> <li>• 720° Interval Difference Method</li> <li>• Pattern Recognition Method</li> </ul> | → NG judgment (Judge misfire occurrence required by the law) (Compare number of misfire with judgment) <ul style="list-style-type: none"> <li>• FTP1.5 times misfire NG judgment</li> <li>• Catalyst damage misfire NG judgment</li> </ul> |
|---|---|--|

For misfire detection, there are three methods such as 180° Interval Difference Method, 720° Interval Difference Method and Pattern Recognition Method.

#### • 180° Interval Difference Method, 720° Interval Difference Method

Transform the time needed for crankshaft movement from BTDC65° to BTDC10° into revolution. As the following, regard the revolution as MNX0. And then regard the former revolution as MNX1, the second former revolution as MNX2, and the third as MNX3, etc.

Use the detecting method below for misfire patterns, and judge misfire occurrence when the result calculated from the formula is out of threshold value.

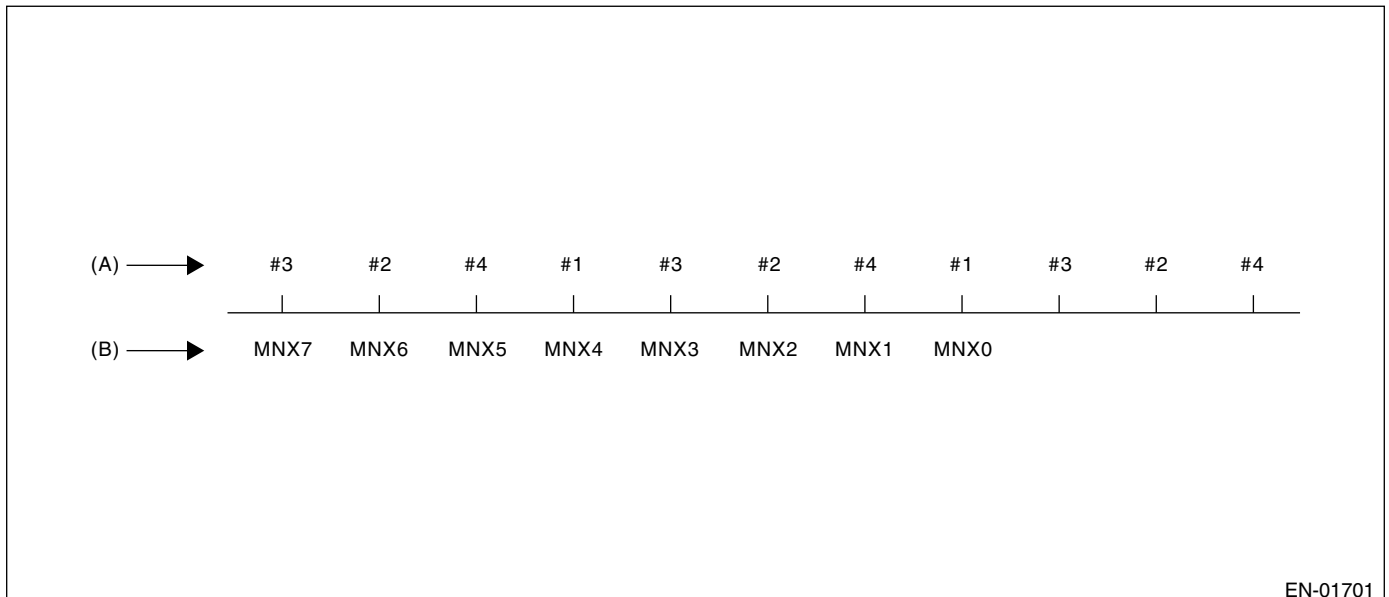

EN-01701

(A) Ignition order

(B) Engine speed (rpm)

# DIAGNOSTIC TROUBLE CODE (DTC) DETECTING CRITERIA

## GENERAL DESCRIPTION

### 180° Interval Difference Method (DDNCON0)

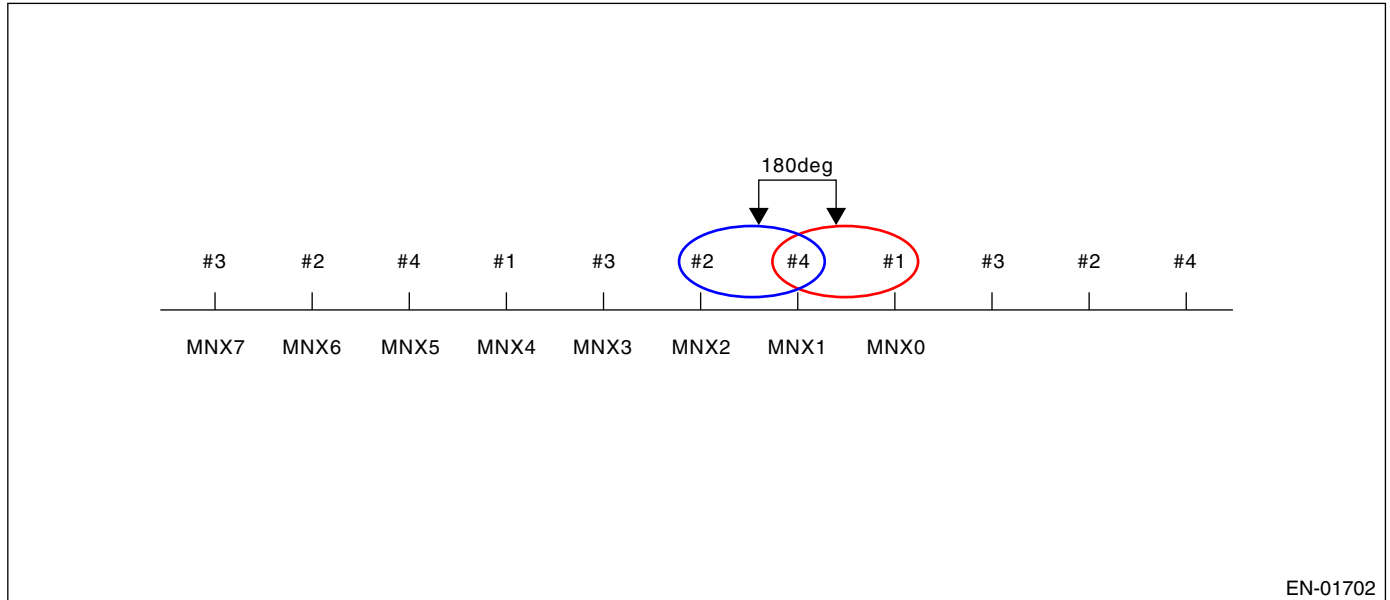

EN-01702

(1)  $DDNCON1 = (MNX\ 1 - MNX\ 2) - (MNX\ 2 - MNX\ 3) \leq \text{Threshold value}$

(2)  $DDNCON0 = (MNX\ 0 - MNX\ 1) - (MNX\ 1 - MNX\ 2) \geq \text{Threshold value}$

Judge misfire when the (1) and (2) above are completed.

### 720° Interval Difference Method (DDNCYL0)

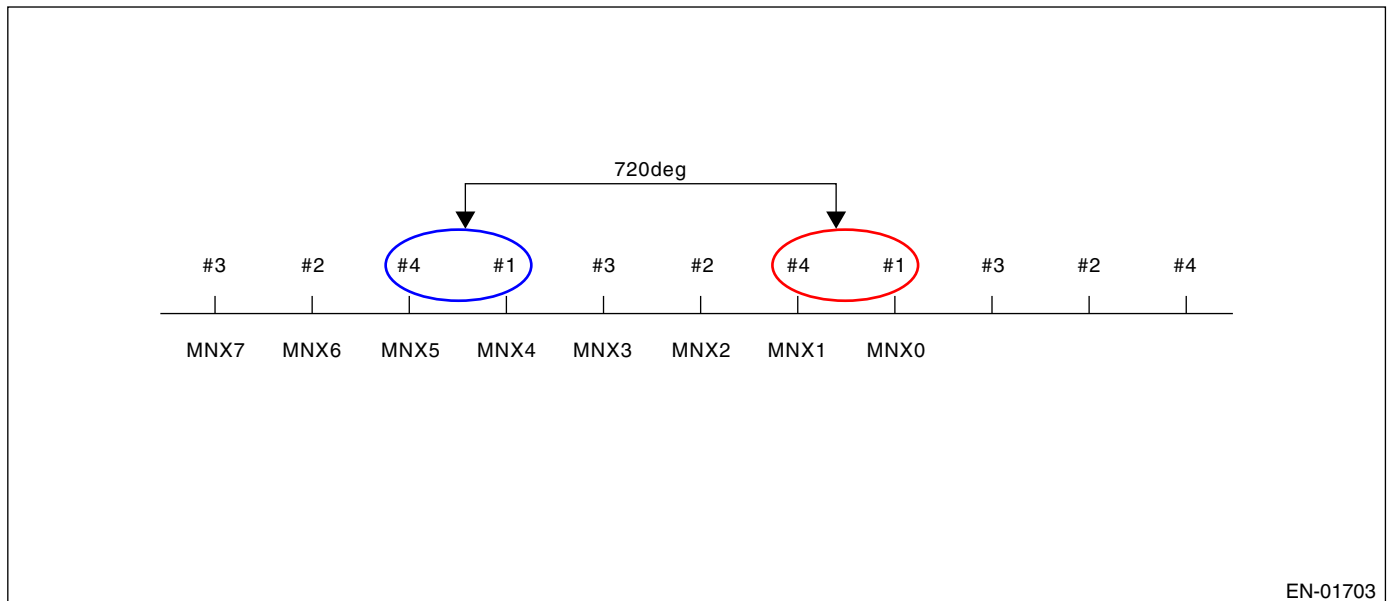

EN-01703

(1)  $DDNCYL4 = (MNX\ 4 - MNX\ 5) - (MNX\ 8 - MNX\ 9) \leq \text{Threshold value}$

(2)  $DDNCYL0 = (MNX\ 0 - MNX\ 1) - (MNX\ 4 - MNX\ 5) \geq \text{Threshold value}$

Judge misfire when the (1) and (2) above are completed.

# DIAGNOSTIC TROUBLE CODE (DTC) DETECTING CRITERIA

GENERAL DESCRIPTION

## • Pattern Recognition Method

Pattern Recognition Method has two patterns such as every time misfire on one cylinder and continuous misfire on two cylinders.

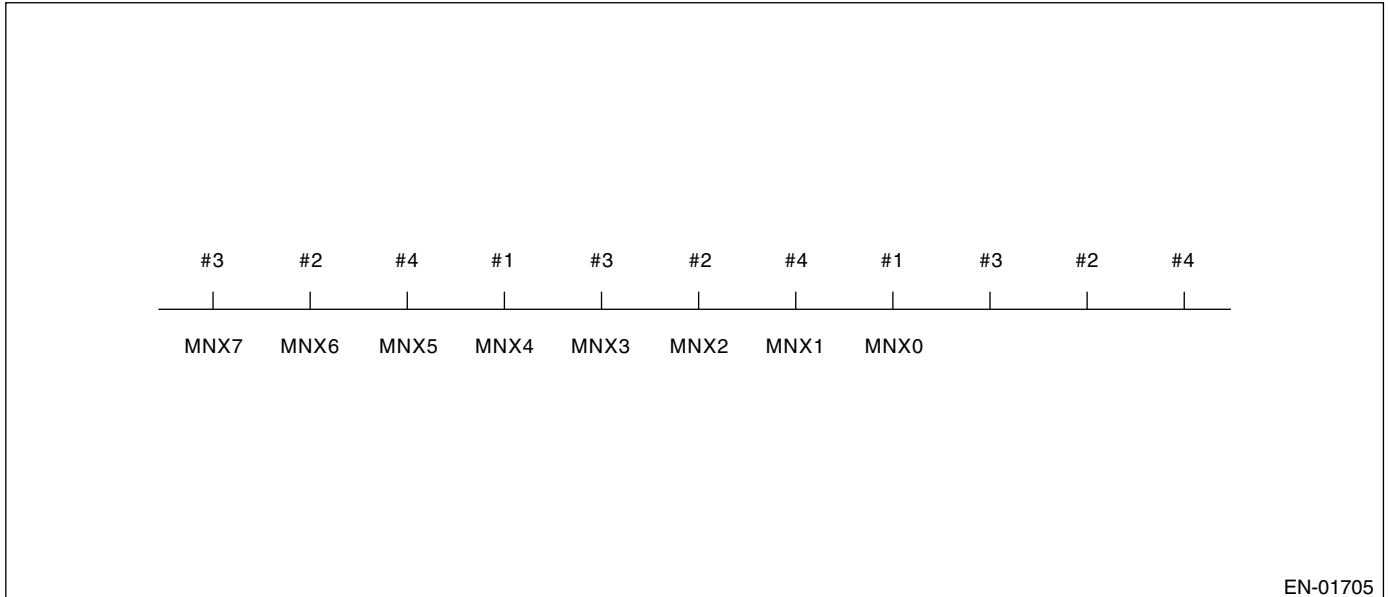

### Every time misfire on one cylinder

Calculate the simple average (calculate MNX 0 – MNX 1) per one hundred ignitions for one cylinder (per four hundred ignitions for four cylinder).

Regard the value calculated for #1 cylinder as AVE1, #2 cylinder as AVE2, and as AVE3, AVE4 like the same way. Judge misfire occurrence when the value calculated from the following formula is larger than threshold value.

(Max. value of AVE1 to AVE4) – AVE<sub>n</sub> (n=1,2,3,4) ≥ threshold value → Judge that misfire occurs.

### Continuous misfire on two cylinders

(1) Two continuous ignitions with “MNX 0 – MNX 1 ≥ threshold value” occurs.

(2) Two continuous ignitions with “MNX 0 – MNX 1 ≤ – (threshold value)” occurs.

Judge misfire occurrence on continuous two cylinders when the judgment criteria (1) and (2) above repeated for four hundred ignition.

## • FTP 1.5 times Misfire (Misfire occurrence level which influences exhaust gas)

### • Judgment Value

Judge malfunction when the misfire rate in 1000 revs. is large.

Malfunction Criteria	Threshold Value
FTP emission	> 1.2% in 1000 revs.

**Time Needed for Diagnosis:** 1000 engine revs.

**Malfunction Indicator Light Illumination:** 2 continuous driving cycles.

## • Catalyst Damage Misfire (Misfire occurrence level which results in catalyst damage)

### • Judgment Value

Judge malfunction when the misfire rate in 200 revs (400 ignitions) is large.

Malfunction Criteria	Threshold Value
Catalyst damage	> See Map 1

# DIAGNOSTIC TROUBLE CODE (DTC) DETECTING CRITERIA

## GENERAL DESCRIPTION

### • Map 1 Fault criteria limit for misfire which would result in catalyst damage

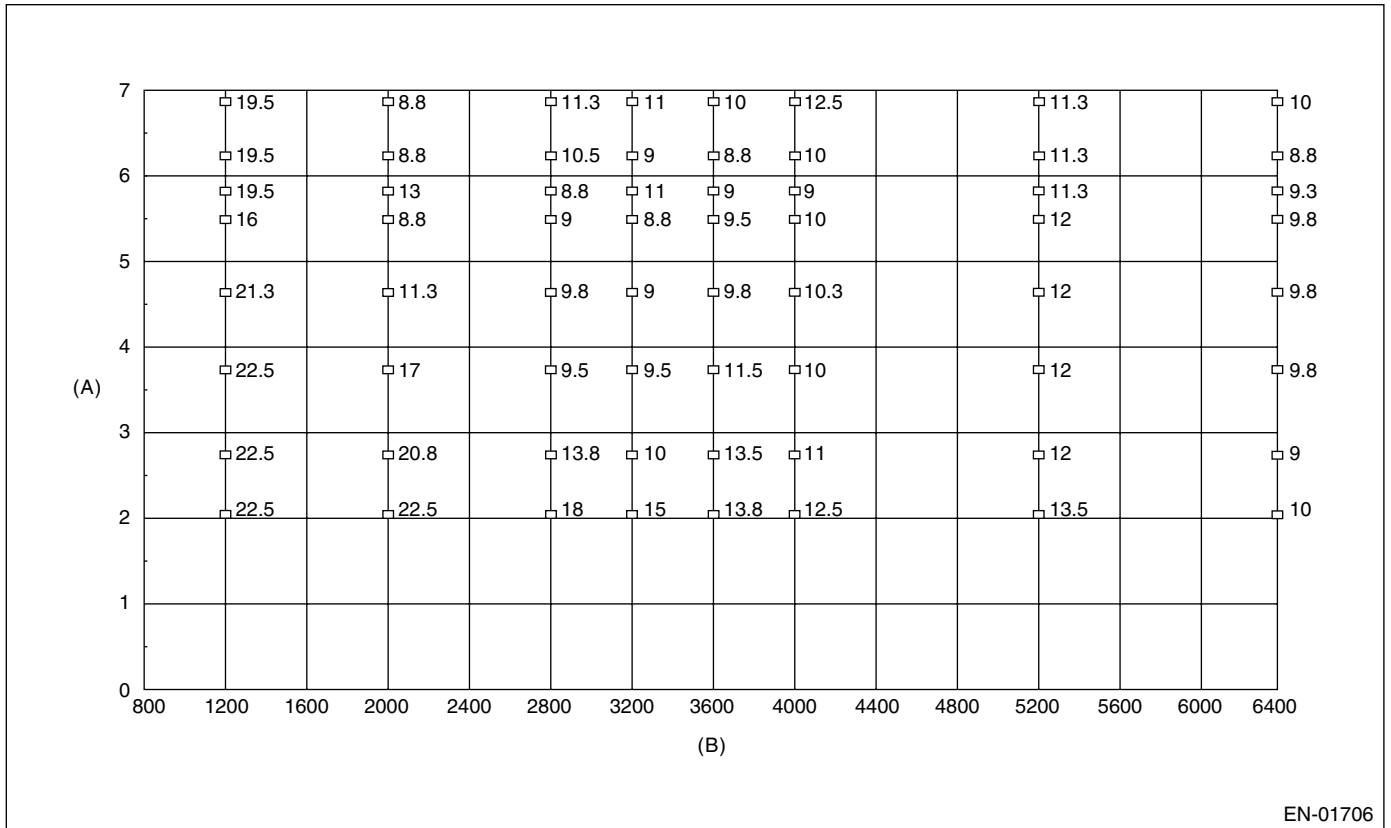

EN-01706

(A) Basic injection pulse (millisecond)      (B) Engine speed (rpm)

**Time Needed for Diagnosis:** 200 engine revs.

**Malfunction Indicator Light Illumination:** Illuminates as soon as malfunction occurs.

### 5. DTC CLEAR CONDITION

- When the OK idling cycle is completed 40 times in a row
- When "Clear Memory" was performed

### 6. MALFUNCTION INDICATOR LIGHT CLEAR CONDITION

- When diagnosed OK with the similar driving for 3 driving cycles in a row
- When "Clear Memory" was performed

### 7. FAIL SAFE

None

### 8. ECM OPERATION AT DTC SETTING

Memorize the freeze frame data. (For test mode \$02)

# DIAGNOSTIC TROUBLE CODE (DTC) DETECTING CRITERIA

GENERAL DESCRIPTION

---

MEMO:

# DIAGNOSTIC TROUBLE CODE (DTC) DETECTING CRITERIA

## GENERAL DESCRIPTION

---

### **AK:DTC P0302 — CYLINDER 2 MISFIRE DETECTED —**

#### **1. OUTLINE OF DIAGNOSIS**

For detecting criteria, refer to DTC P0301 — CYLINDER 1 MISFIRE DETECTED —. <Ref. to GD(H4SO)-88, DTC P0301 — CYLINDER 1 MISFIRE DETECTED —, Diagnostic Trouble Code (DTC) Detecting Criteria.>

### **AL:DTC P0303 — CYLINDER 3 MISFIRE DETECTED —**

#### **1. OUTLINE OF DIAGNOSIS**

For detecting criteria, refer to DTC P0301 — CYLINDER 1 MISFIRE DETECTED —. <Ref. to GD(H4SO)-88, DTC P0301 — CYLINDER 1 MISFIRE DETECTED —, Diagnostic Trouble Code (DTC) Detecting Criteria.>

### **AM:DTC P0304 — CYLINDER 4 MISFIRE DETECTED —**

#### **1. OUTLINE OF DIAGNOSIS**

For detecting criteria, refer to DTC P0301 — CYLINDER 1 MISFIRE DETECTED —. <Ref. to GD(H4SO)-88, DTC P0301 — CYLINDER 1 MISFIRE DETECTED —, Diagnostic Trouble Code (DTC) Detecting Criteria.>

**DIAGNOSTIC TROUBLE CODE (DTC) DETECTING CRITERIA**

GENERAL DESCRIPTION

---

MEMO:

# DIAGNOSTIC TROUBLE CODE (DTC) DETECTING CRITERIA

## GENERAL DESCRIPTION

### AN:DTC P0327 — KNOCK SENSOR 1 CIRCUIT LOW INPUT (BANK 1 OR SINGLE SENSOR) —

#### 1. OUTLINE OF DIAGNOSIS

Detect the open or short circuit of knock sensor.  
Judge NG when out of the standard value.

#### 2. COMPONENT DESCRIPTION

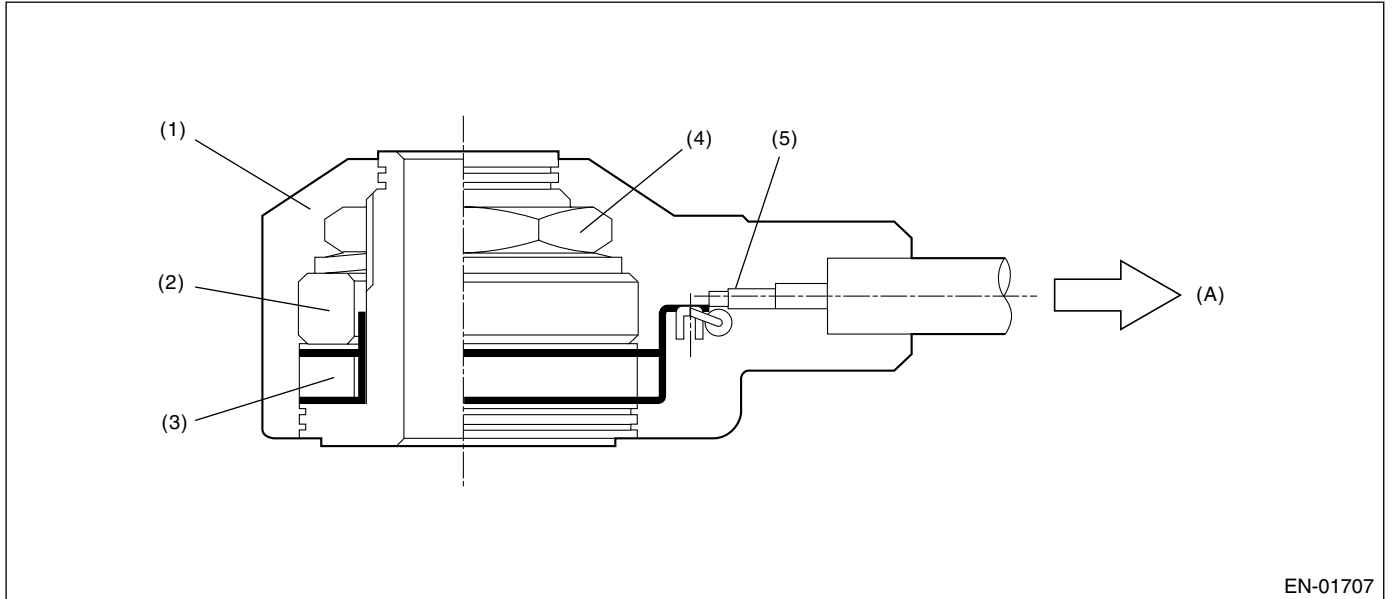

- (1) Case
- (2) Weight
- (3) Piezoelectric element

- (4) Nut
- (5) Resistance

- (A) To knock sensor harness

#### 3. ENABLE CONDITION

Secondary Parameters	Enable Conditions
Ignition switch	ON

#### 4. GENERAL DRIVE CYCLE

Always perform the diagnosis continuously.

#### 5. DIAGNOSTIC METHOD

Judge NG when the continuous time until completing the malfunction criteria below becomes more than the time (1 second) needed for diagnosis. Judge OK when the malfunction criteria below are not completed.

##### Judgment Value

Malfunction Criteria	Threshold Value
Output voltage	< 0.6 V

**Time Needed for Diagnosis:** 1 second

**Malfunction Indicator Light Illumination:** Illuminates as soon as malfunction occurs.

#### 6. DTC CLEAR CONDITION

- When the OK idling cycle is completed 40 times in a row
- When "Clear Memory" was performed



# DIAGNOSTIC TROUBLE CODE (DTC) DETECTING CRITERIA

GENERAL DESCRIPTION

---

## 7. MALFUNCTION INDICATOR LIGHT CLEAR CONDITION

- When the OK driving cycle was completed 3 times in a row
- When "Clear Memory" was performed

## 8. FAIL SAFE

- (1) Stop whole compensation, partial compensation, knock cancel compensation in ignition timing calculation at normal.
- (2) Knock cancel compensation of low engine coolant temperature is fixed value (7°C).
- (3) Stop partial compensation calculation of ignition leaning.

## 9. ECM OPERATION AT DTC SETTING

Memorize the freeze frame data. (For test mode \$02)

# DIAGNOSTIC TROUBLE CODE (DTC) DETECTING CRITERIA

## GENERAL DESCRIPTION

### AO:DTC P0328 — KNOCK SENSOR 1 CIRCUIT HIGH INPUT (BANK 1 OR SINGLE SENSOR) —

#### 1. OUTLINE OF DIAGNOSIS

Detect the open or short circuit of knock sensor.  
Judge NG when out of the standard value.

#### 2. COMPONENT DESCRIPTION

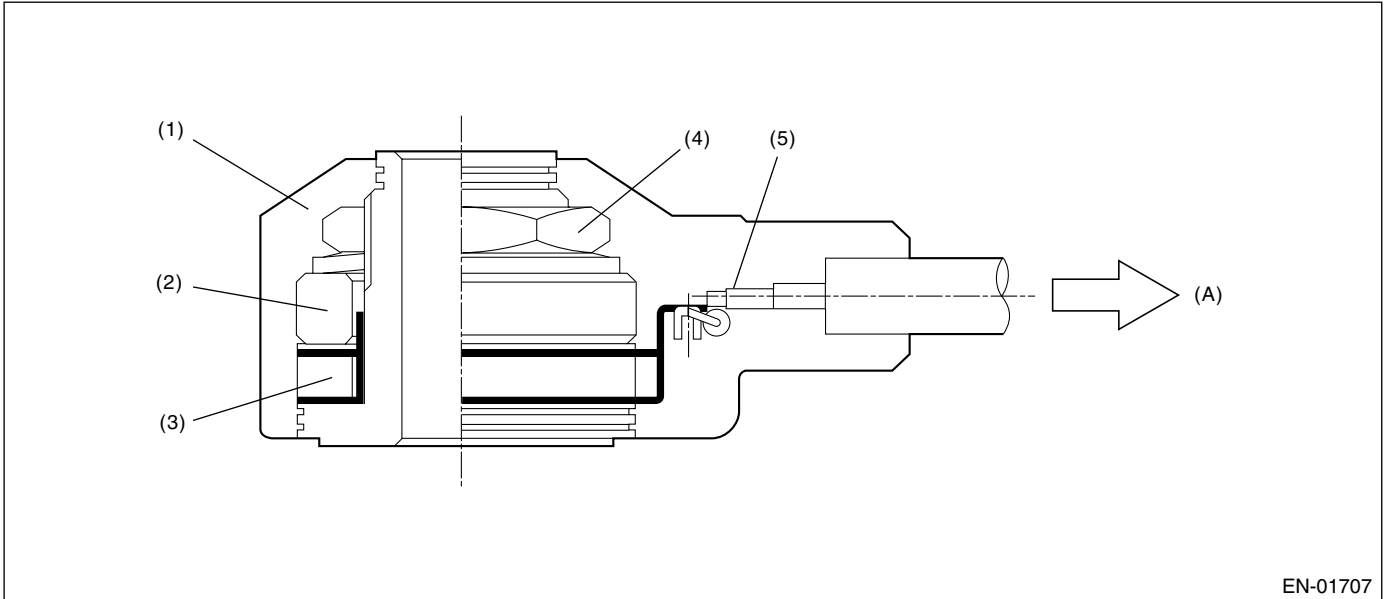

- (1) Case
- (2) Weight
- (3) Piezoelectric element

- (4) Nut
- (5) Resistance

- (A) To knock sensor harness

#### 3. ENABLE CONDITION

Secondary Parameters	Enable Conditions
Ignition switch	ON

#### 4. GENERAL DRIVE CYCLE

Always perform the diagnosis continuously.

#### 5. DIAGNOSTIC METHOD

Judge NG when the continuous time of completing the malfunction criteria below becomes more than the time (1 second) needed for diagnosis. Judge OK when the malfunction criteria below are not completed.

##### Judgment Value

Malfunction Criteria	Threshold Value
Output voltage	> 3.5 V

**Time Needed for Diagnosis:** 1 second

**Malfunction Indicator Light Illumination:** Illuminates as soon as malfunction occurs.

#### 6. DTC CLEAR CONDITION

- When the OK idling cycle is completed 40 times in a row
- When "Clear Memory" was performed

# DIAGNOSTIC TROUBLE CODE (DTC) DETECTING CRITERIA

GENERAL DESCRIPTION

---

## 7. MALFUNCTION INDICATOR LIGHT CLEAR CONDITION

- When the OK driving cycle was completed 3 times in a row
- When "Clear Memory" was performed

## 8. FAIL SAFE

- (1) Stop whole compensation, partial compensation, knock cancel compensation in ignition timing calculation at normal.
- (2) Knock cancel compensation of low engine coolant temperature is fixed value (7°C).
- (3) Stop partial compensation calculation of ignition leaning.

## 9. ECM OPERATION AT DTC SETTING

Memorize the freeze frame data. (For test mode \$02)

# DIAGNOSTIC TROUBLE CODE (DTC) DETECTING CRITERIA

## GENERAL DESCRIPTION

### AP:DTC P0335 — CRANKSHAFT POSITION SENSOR “A” CIRCUIT —

#### 1. OUTLINE OF DIAGNOSIS

Detect the open or short circuit of crankshaft position sensor.

Normally, the crankshaft position sensor signal and camshaft position sensor signal are input as shown below. But judge NG when continuing not to input the crankshaft position sensor signal.

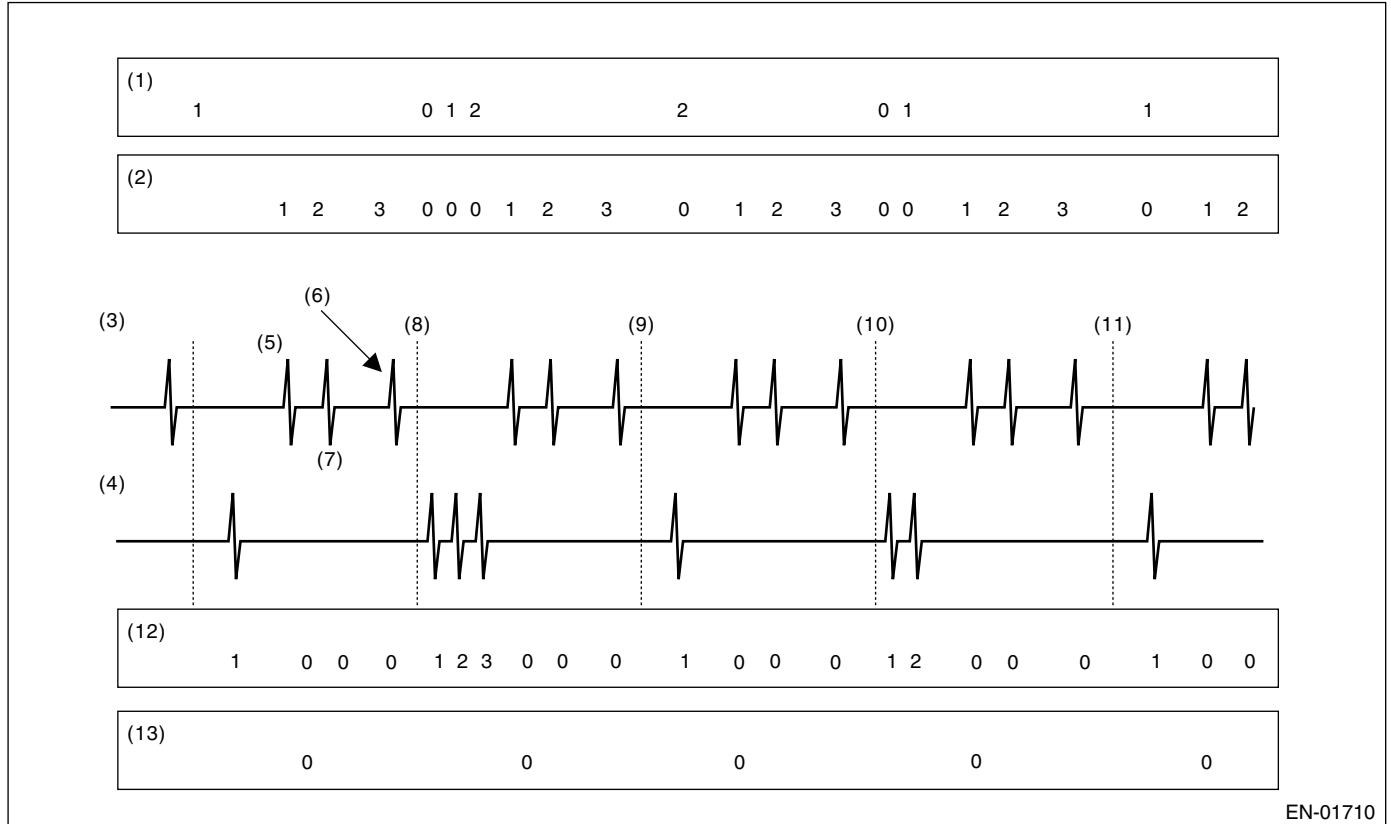

EN-01710

- |  |                         |   |
|--|-------------------------|---|
| (1) NG counter of crankshaft position sensor   | (5) BTDC 97° CA         | (11) #4 compression TDC                       |
| (2) Signal count of crankshaft position sensor | (6) BTDC 10° CA         | (12) Signal count of camshaft position sensor |
| (3) Crankshaft position sensor signal          | (7) BTDC 65° CA         | (13) NG counter of relative position          |
| (4) Camshaft position sensor signal            | (8) #1 compression TDC  |   |
|  | (9) #3 compression TDC  |   |
|  | (10) #2 compression TDC |   |

#### • Cylinder judgment method

When inputting BTDC97°CA crankshaft position sensor signal, judge what cylinder piston is brought to the top dead center of compression by camshaft position sensor signal number.

Camshaft position sensor signal number	Next top dead center of compression
3	#3
1	#2
2	#4
1	#1

# DIAGNOSTIC TROUBLE CODE (DTC) DETECTING CRITERIA

GENERAL DESCRIPTION

## 2. COMPONENT DESCRIPTION

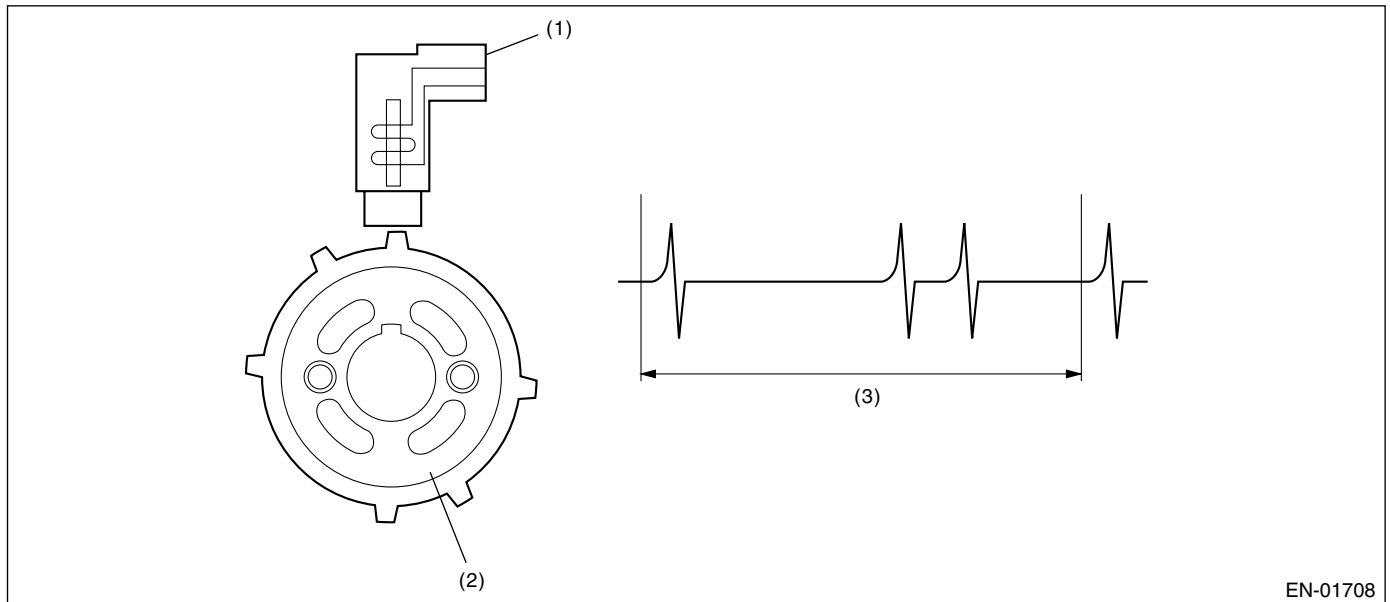

EN-01708

(1) Crankshaft position sensor

(2) Crankshaft sprocket

(3) Crankshaft half-turn

## 3. ENABLE CONDITION

Perform the diagnosis without condition.

## 4. GENERAL DRIVING CYCLE

Always perform the diagnosis continuously.

## 5. DIAGNOSTIC METHOD

Judge OK and clear the NG when the malfunction criteria below are completed.

### Judgment Value

Malfunction Criteria	Threshold Value
Camshaft position sensor signal	$\geq 24$
Crankshaft position sensor signal	Detect in warm-up condition

When the crankshaft position sensor signal is input, clear the above camshaft position sensor signal.

**Time Needed for Diagnosis:** 7 revs.

**Malfunction Indicator Light Illumination:** Illuminates as soon as malfunction occurs.

## 6. DTC CLEAR CONDITION

- When the OK idling cycle was completed 40 times in a row
- When "Clear Memory" was performed

## 7. MALFUNCTION INDICATOR LIGHT CLEAR CONDITION

- When the OK driving cycle was completed 3 times in a row
- When "Clear Memory" was performed

## 8. FAIL SAFE

None

## 9. ECM OPERATION AT DTC SETTING

Memorize the freeze frame data. (For test mode \$02)

# DIAGNOSTIC TROUBLE CODE (DTC) DETECTING CRITERIA

## GENERAL DESCRIPTION

### AQ:DTC P0336 — CRANKSHAFT POSITION SENSOR “A” CIRCUIT RANGE/ PERFORMANCE —

#### 1. OUTLINE OF DIAGNOSIS

Detect the malfunction of crankshaft position sensor output property.

Compare the normal crankshaft position sensor signal with normal camshaft position sensor signal. When each input number does not correspond, judge NG.

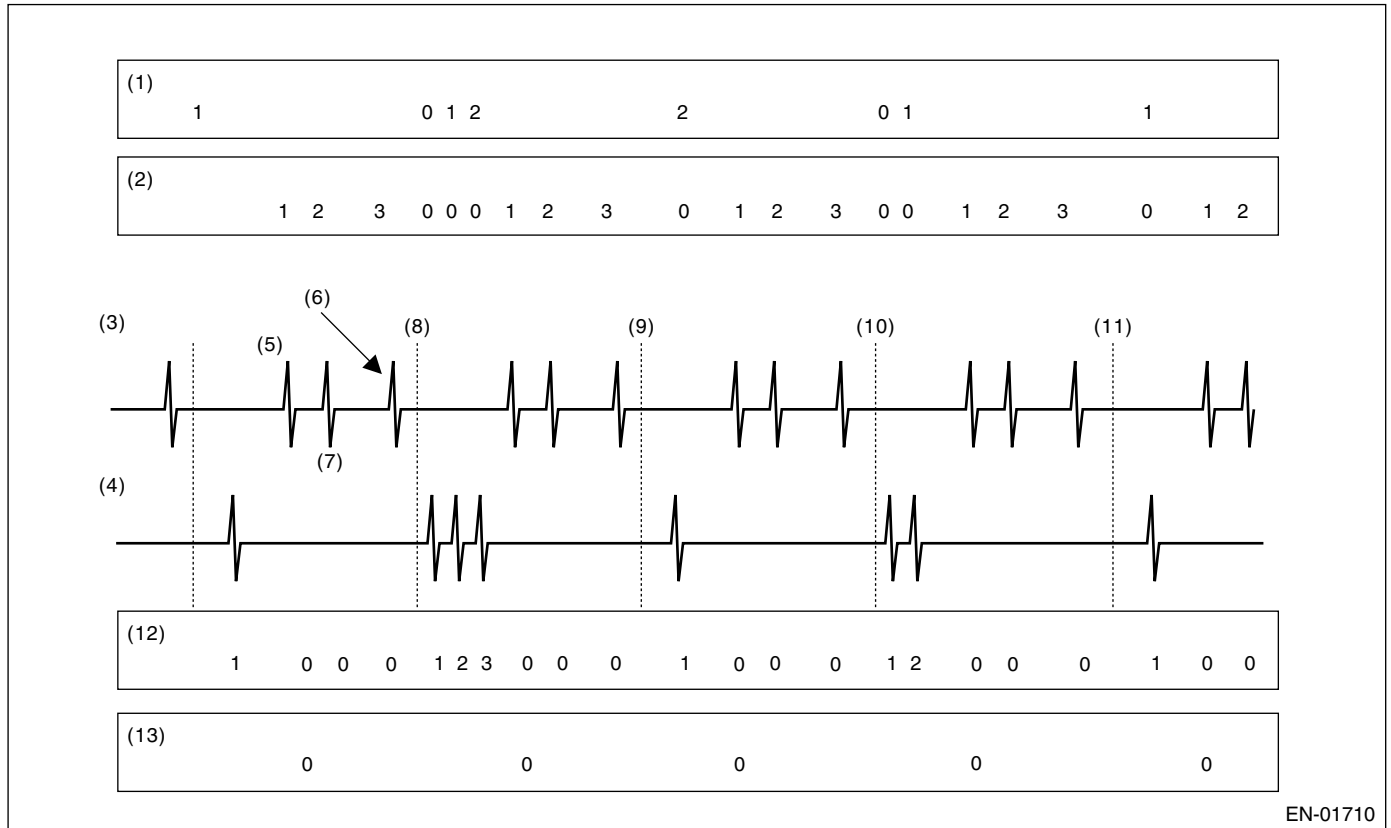

EN-01710

- |  |                         |   |
|--|-------------------------|---|
| (1) NG counter of crankshaft position sensor   | (5) BTDC 97° CA         | (11) #4 compression TDC                       |
| (2) Signal count of crankshaft position sensor | (6) BTDC 10° CA         | (12) Signal count of camshaft position sensor |
| (3) Crankshaft position sensor signal          | (7) BTDC 65° CA         | (13) NG counter of relative position          |
| (4) Camshaft position sensor signal            | (8) #1 compression TDC  |   |
|  | (9) #3 compression TDC  |   |
|  | (10) #2 compression TDC |   |

#### • Cylinder judgment method

When BTDC97°CA crankshaft position sensor signal is input, judge what cylinder piston is brought to the top dead center of compression by camshaft position sensor signal number.

Camshaft position sensor signal number	Next top dead center of compression
3	#3
1	#2
2	#4
1	#1

## 2. COMPONENT DESCRIPTION

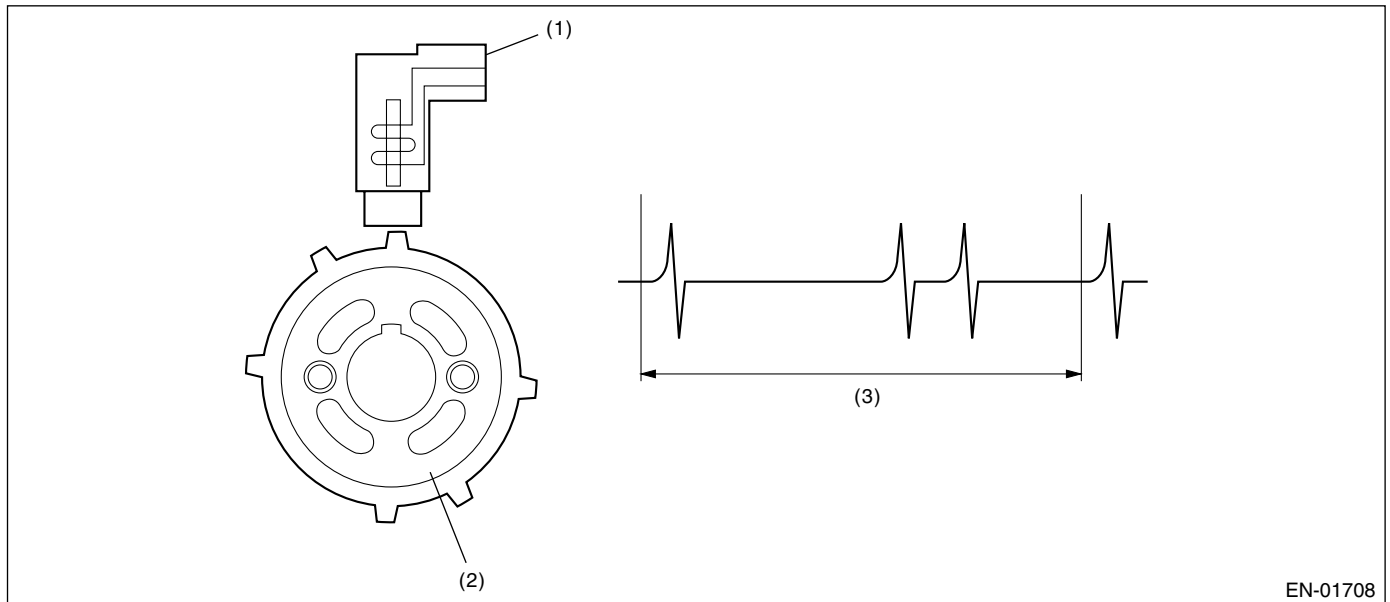

EN-01708

(1) Crankshaft position sensor

(2) Crankshaft sprocket

(3) Crankshaft half-turn

## 3. ENABLE CONDITION

Perform the diagnosis without condition.

## 4. GENERAL DRIVE CYCLE

Always perform the diagnosis continuously.

## 5. DIAGNOSTIC METHOD

When the camshaft position sensor signal is input, compare the total crankshaft position sensor signal number from occasion of previous camshaft position sensor signal input to now with crankshaft position sensor signal number at normal. Increase NG judgment counter when each number does not correspond at once. Judge NG when each number does not correspond sequentially (NG counter  $\geq 32$ ). Judge OK and clear NG when the crankshaft position sensor signal number corresponds (NG counter = 0).

### Judgment Value

Malfunction Criteria	Threshold Value
Fault counter	$\geq 32$

**Time Needed for Diagnosis:** 10 revs.

**Malfunction Indicator Light Illumination:** Illuminates as soon as malfunction occurs.

## 6. DTC CLEAR CONDITION

- When the OK idling cycle was completed 40 times in a row
- When "Clear Memory" was performed

## 7. MALFUNCTION INDICATOR LIGHT CLEAR CONDITION

- When the OK driving cycle was completed 3 times in a row
- When "Clear Memory" was performed

## 8. FAIL SAFE

None

## 9. ECM OPERATION AT DTC SETTING

Memorize the freeze frame data. (For test mode \$02)

# DIAGNOSTIC TROUBLE CODE (DTC) DETECTING CRITERIA

## GENERAL DESCRIPTION

### AR:DTC P0340 — CAMSHAFT POSITION SENSOR “A” CIRCUIT (BANK 1 OR SINGLE SENSOR) —

#### 1. OUTLINE OF DIAGNOSIS

Detect the malfunction of crankshaft position sensor output property.

Judge NG when continuing not to input the camshaft position sensor signal.

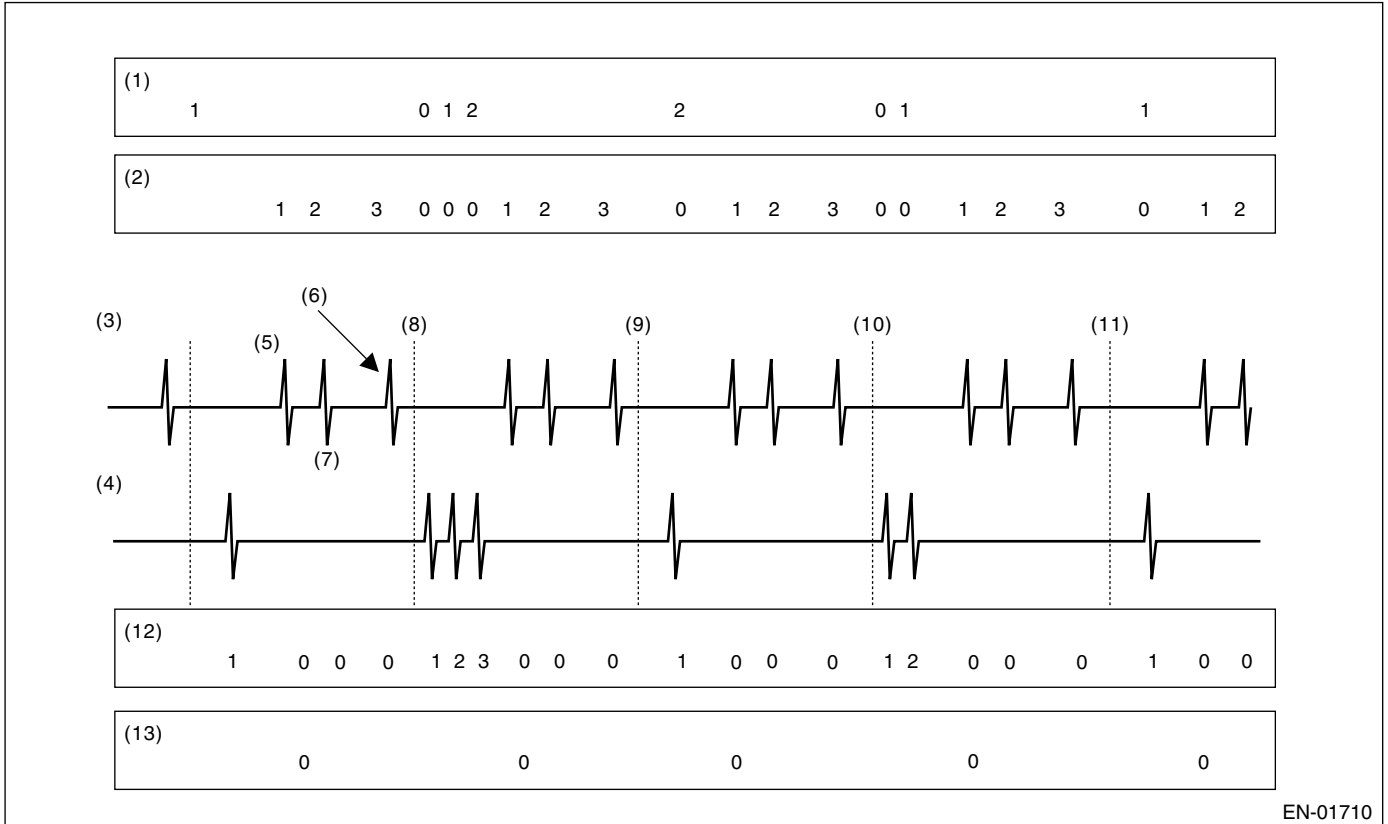

EN-01710

- |  |                         |   |
|--|-------------------------|---|
| (1) NG counter of crankshaft position sensor   | (5) BTDC 97° CA         | (11) #4 compression TDC                       |
| (2) Signal count of crankshaft position sensor | (6) BTDC 10° CA         | (12) Signal count of camshaft position sensor |
| (3) Crankshaft position sensor signal          | (7) BTDC 65° CA         | (13) NG counter of relative position          |
| (4) Camshaft position sensor signal            | (8) #1 compression TDC  |   |
|  | (9) #3 compression TDC  |   |
|  | (10) #2 compression TDC |   |

#### • Cylinder judgment method

When BTDC97°CA crankshaft position sensor signal is input, judge what cylinder piston is brought to the top dead center of compression by camshaft position sensor signal number.

Camshaft position sensor signal number	Next top dead center of compression
3	#3
1	#2
2	#4
1	#1



# DIAGNOSTIC TROUBLE CODE (DTC) DETECTING CRITERIA

GENERAL DESCRIPTION

## 2. COMPONENT DESCRIPTION

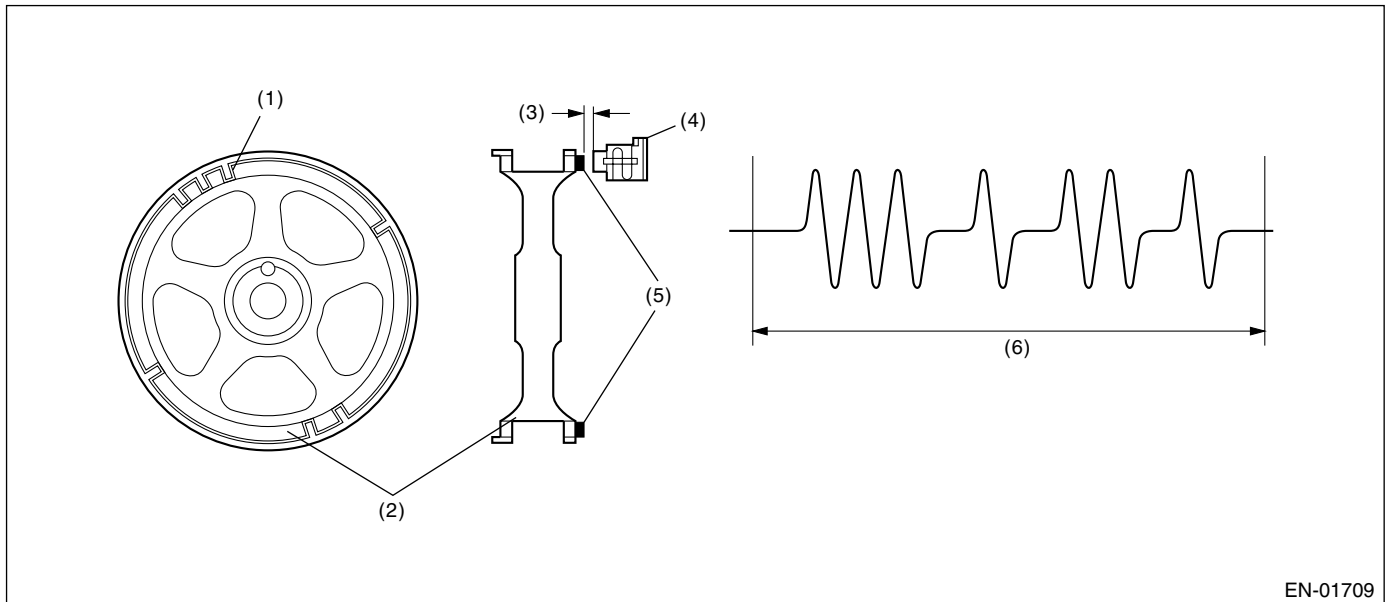

EN-01709

- |                       |                              |  |
|-----------------------|------------------------------|--|
| (1) Boss              | (4) Camshaft position sensor | (6) Camshaft one turn (Crankshaft two turns) |
| (2) Camshaft sprocket | (5) Boss                     |  |
| (3) Air gap           |                              |  |

## 3. ENABLE CONDITION

Perform the diagnosis without condition.

## 4. GENERAL DRIVING CYCLE

Always perform the diagnosis continuously.

## 5. DIAGNOSTIC METHOD

When many crankshaft position sensor signals were input without camshaft position sensor signal input, judge OK and clear NG.

### Judgment Value

Malfunction Criteria	Threshold Value
Crankshaft position sensor signal	$\geq 36$
Camshaft position sensor signal	Detect in warm-up condition

**Time Needed for Diagnosis:** 6 revs.

**Malfunction Indicator Light Illumination:** Illuminates as soon as malfunction occurs.

## 6. DTC CLEAR CONDITION

- When the OK idling cycle was completed 40 times in a row
- When "Clear Memory" was performed

## 7. MALFUNCTION INDICATOR LIGHT CLEAR CONDITION

- When the OK driving cycle was completed 3 times in a row
- When "Clear Memory" was performed

## 8. FAIL SAFE

None

## 9. ECM OPERATION AT DTC SETTING

Memorize the freeze frame data. (For test mode \$02)

# DIAGNOSTIC TROUBLE CODE (DTC) DETECTING CRITERIA

## GENERAL DESCRIPTION

### AS:DTC P0341 — CAMSHAFT POSITION SENSOR “A” CIRCUIT RANGE/PERFORMANCE (BANK 1 OR SINGLE SENSOR) —

#### 1. OUTLINE OF DIAGNOSIS

Detect the malfunction of crankshaft position sensor output property.

Compare the normal crankshaft position sensor signal with normal camshaft position sensor signal. When each input number does not correspond, judge NG.

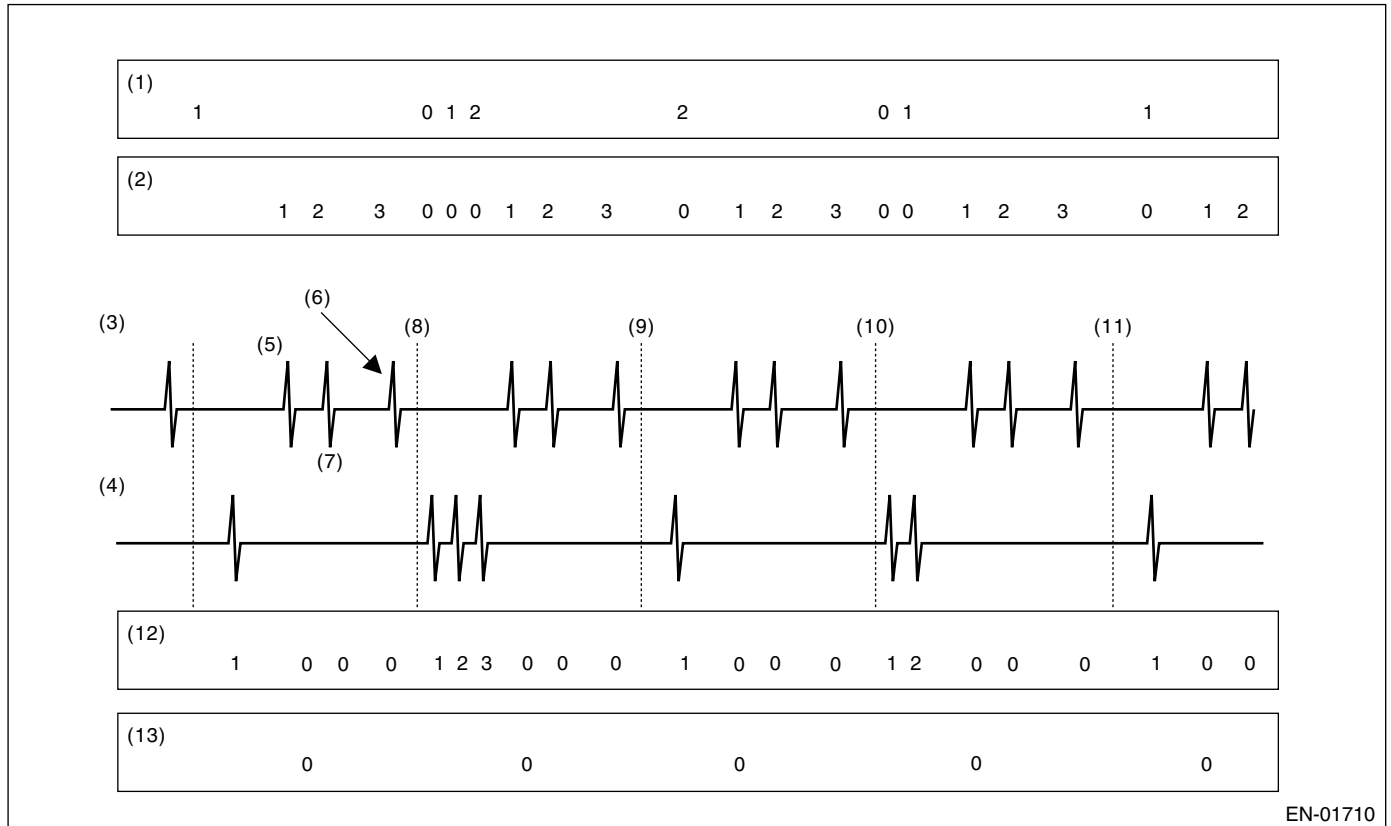

EN-01710

- |  |                         |   |
|--|-------------------------|---|
| (1) NG counter of crankshaft position sensor   | (5) BTDC 97° CA         | (11) #4 compression TDC                       |
| (2) Signal count of crankshaft position sensor | (6) BTDC 10° CA         | (12) Signal count of camshaft position sensor |
| (3) Crankshaft position sensor signal          | (7) BTDC 65° CA         | (13) NG counter of relative position          |
| (4) Camshaft position sensor signal            | (8) #1 compression TDC  |   |
|  | (9) #3 compression TDC  |   |
|  | (10) #2 compression TDC |   |

#### • Cylinder judgment method

When BTDC97°CA crankshaft position sensor signal is input, judge what cylinder piston is brought to the top dead center of compression by camshaft position sensor signal number.

Camshaft position sensor signal number	Next top dead center of compression
3	#3
1	#2
2	#4
1	#1

# DIAGNOSTIC TROUBLE CODE (DTC) DETECTING CRITERIA

GENERAL DESCRIPTION

## 2. COMPONENT DESCRIPTION

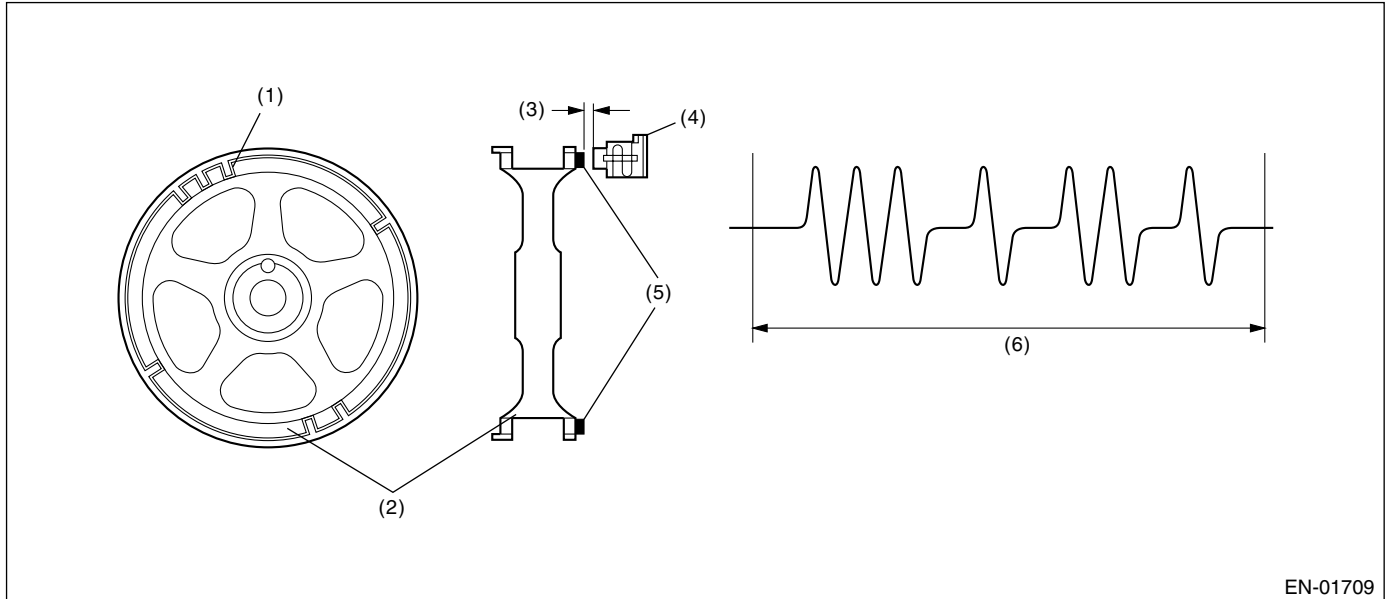

EN-01709

- (1) Boss  
(2) Camshaft sprocket  
(3) Air gap  
(4) Camshaft position sensor  
(5) Boss  
(6) Camshaft one turn (Crankshaft two turns)

## 3. ENABLE CONDITION

Perform the diagnosis without condition.

## 4. GENERAL DRIVE CYCLE

Always perform the diagnosis continuously.

## 5. DIAGNOSTIC METHOD

When BTDC97°CA crankshaft position sensor signal is input, compare the camshaft position sensor signal number in past 4 times with camshaft position sensor signal number at normal. Increase NG judgment counter when each number does not correspond at once, judge OK and clear NG when the camshaft position sensor signal is normal.

### Judgment Value

Malfunction Criteria	Threshold Value
Fault counter	≥ 32

**Time Needed for Diagnosis:** 6 revs.

**Malfunction Indicator Light Illumination:** Illuminates as soon as malfunction occurs.

## 6. DTC CLEAR CONDITION

- When the OK idling cycle was completed 40 times in a row
- When "Clear Memory" was performed

## 7. MALFUNCTION INDICATOR LIGHT CLEAR CONDITION

- When the OK driving cycle was completed 3 times in a row
- When "Clear Memory" was performed

## 8. FAIL SAFE

None

## 9. ECM OPERATION AT DTC SETTING

Memorize the freeze frame data. (For test mode \$02)

# DIAGNOSTIC TROUBLE CODE (DTC) DETECTING CRITERIA

## GENERAL DESCRIPTION

### AT:DTC P0400 — EXHAUST GAS RECIRCULATION FLOW —

#### 1. OUTLINE OF DIAGNOSIS

Detect the malfunction of EGR system.

Intake manifold pressure (negative pressure) is stable because the throttle valve is fully closed during the fuel shut-off in deceleration. In this case, the intake manifold pressure changes when EGR valve is opened or closed. Judge EGR system is OK or NG according to intake manifold pressure change amount.

#### 2. COMPONENT DESCRIPTION

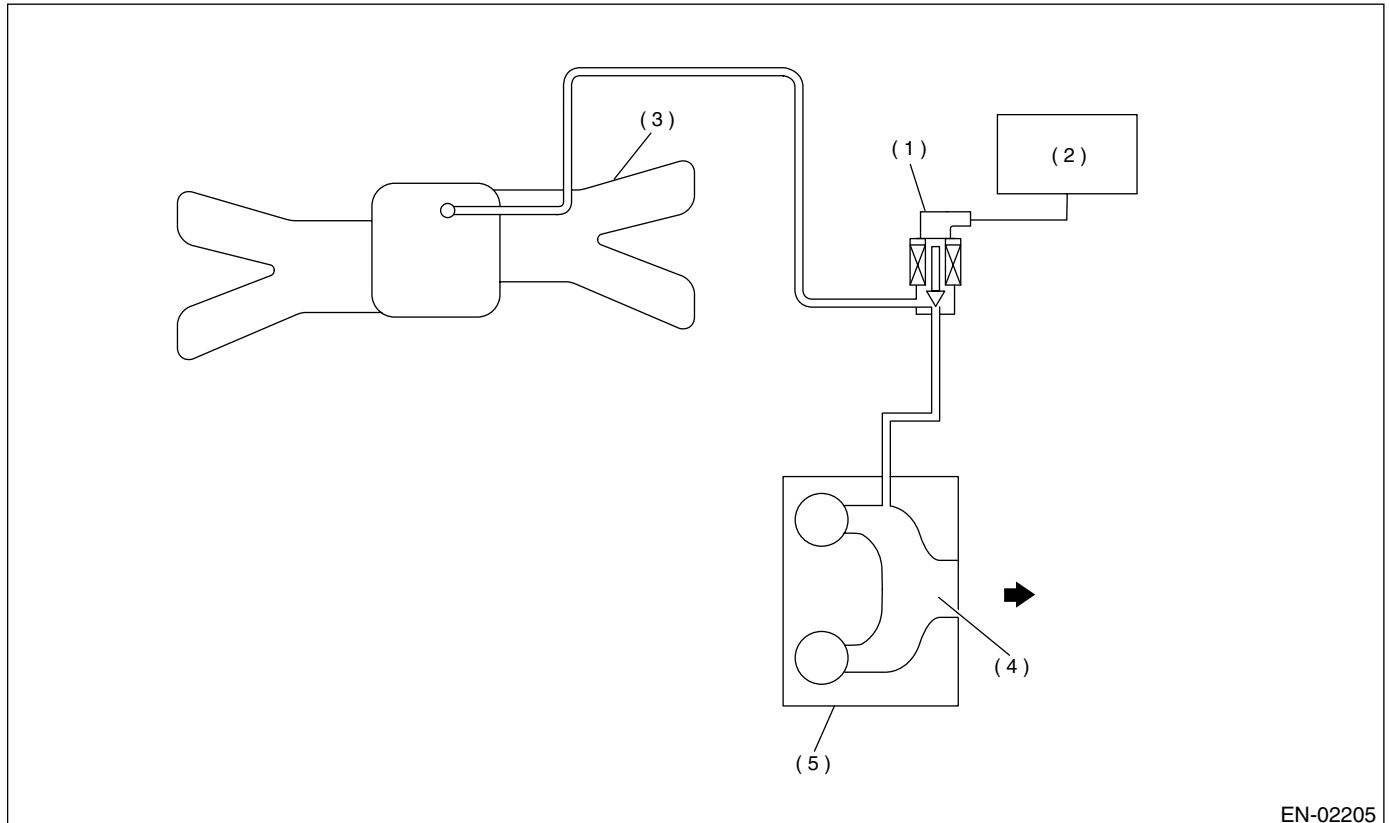

- (1) EGR valve
- (2) Engine control module (ECM)

- (3) Intake manifold
- (4) Export port

- (5) Cylinder head LH

# DIAGNOSTIC TROUBLE CODE (DTC) DETECTING CRITERIA

GENERAL DESCRIPTION

## 3. ENABLE CONDITION

Secondary Parameters	Enable Conditions
After engine starting	40 secs. or more
Engine coolant temperature	≥ 75°C (167°F)
Engine speed	1,200 — 3,000 rpm
Intake manifold pressure	13.3 — 36.0 kPa (100 — 270 mmHg, 3.94 — 10.63 inHg)
Estimated ambient temperature	≥ 5°C (41°F)
Throttle position	< 0.25°
Battery voltage	> 10.9 V
Atmospheric pressure	≥ 75.7 kPa (568 mmHg, 22.36 inHg)
Vehicle speed	≥ 53 km/h (33 MPH)
Fuel shut-off function	In operation
Neutral switch	OFF or 1 seconds changing from "ON" to "OFF"
After load input switch operation (air conditioner, power steering, lights, rear defroster, heater fan and radiator fan)	5 secs. or more

## 4. GENERAL DRIVING CYCLE

Perform the diagnosis only once at the fuel shut-off in deceleration in vehicle speed more than 40 km/h (25 MPH). Pay attention to vehicle speed and engine speed. (The diagnosis is not completed if vehicle speed and engine speed are out of condition due to deceleration.)

# DIAGNOSTIC TROUBLE CODE (DTC) DETECTING CRITERIA

## GENERAL DESCRIPTION

### 5. DIAGNOSTIC METHOD

Measure the pressure in the following procedures when the enable conditions are completed, and then diagnosis by calculating the result.

- (1) PMOF1 is equal to the intake manifold pressure at enable condition completed, and EGR target step is set to 50 steps (almost fully opened).
- (2) PMON is equal to the intake manifold pressure in 1 second after EGR target step is set 50 steps (when enable conditions are completed), and EGR target step is set to 0 step.
- (3) PMOF2 is equal to the intake manifold pressure in 1 second after EGR target step is set to 0 step (in 2 seconds after enable conditions are completed).

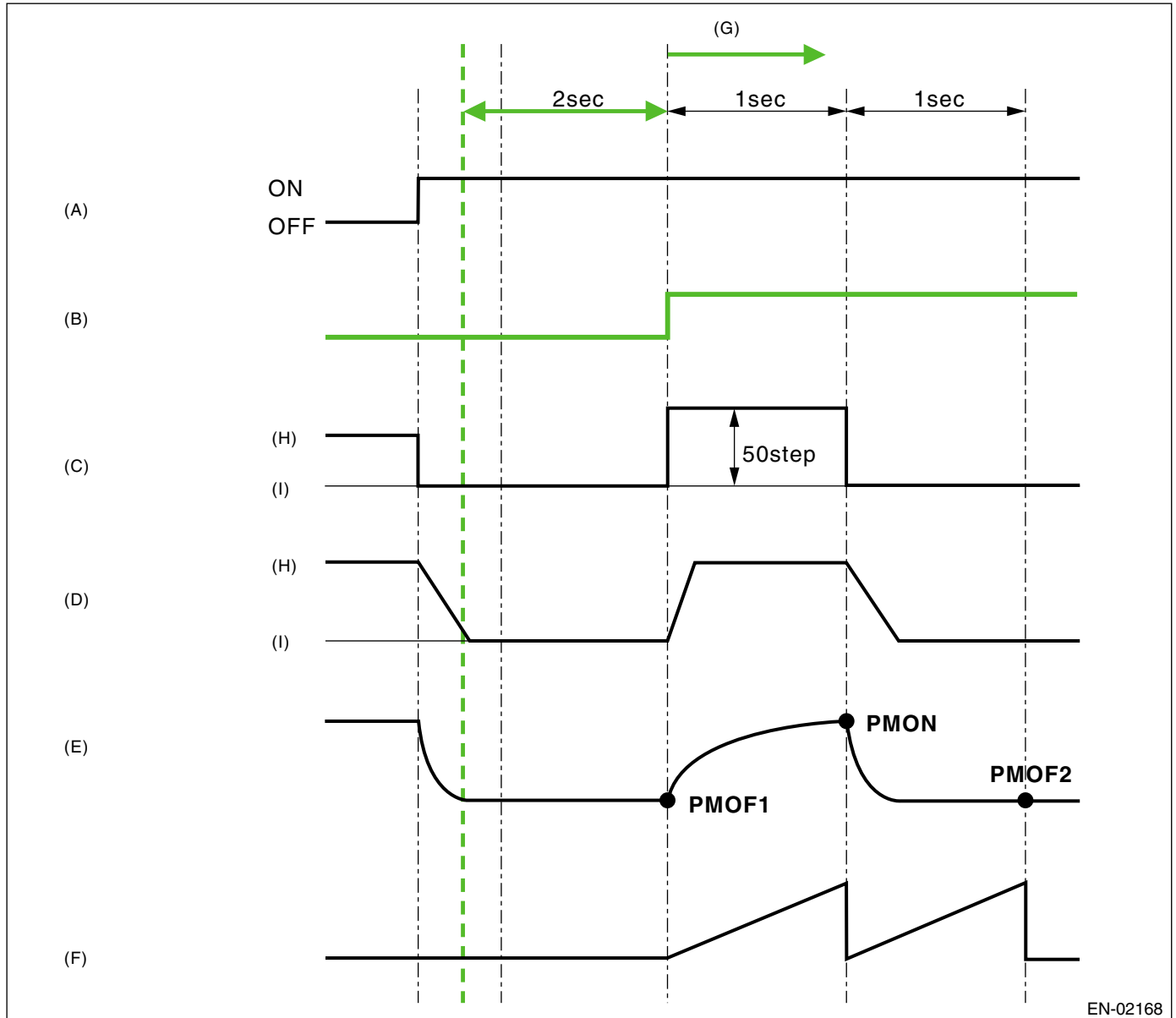

EN-02168

- (A) Fuel shut-off in deceleration
- (B) Diagnosis enable condition
- (C) EGR target step
- (D) EGR actual step

- (E) Intake manifold pressure (At normal condition)
- (F) Diagnosis mode timer
- (G) Diagnosis starts.

- (H) Open
- (I) Close

# DIAGNOSTIC TROUBLE CODE (DTC) DETECTING CRITERIA

GENERAL DESCRIPTION

(4) Calculate the judged value using the following formula.

$$\text{Judged value} = [\text{PMON} - (\text{PMOF1} + \text{PMOF2})/2]$$

Judge NG when the malfunction criteria bellows are completed. Judge OK and clear NG when the malfunction criteria bellows are not completed.

## Judgment Value

Malfunction Criteria	Threshold Value	DTC
Judged value	< 2.48 kPa (18.63 mmHg, 0.733 inHg) ≥ 146.6 kPa (1,100 mmHg, 43.31 inHg)	P0400

**Time Needed for Diagnosis:** 3 seconds

**Malfunction Indicator Light Illumination:** 2 continuous driving cycles.

## 6. DTC CLEAR CONDITION

- When the OK idling cycle was completed 40 times in a row
- When "Clear Memory" was performed

## 7. MALFUNCTION INDICATOR LIGHT CLEAR CONDITION

- When the OK driving cycle was completed 3 times in a row
- When "Clear Memory" was performed

## 8. FAIL SAFE

None

## 9. ECM OPERATION AT DTC SETTING

- Memorize the freeze frame data. (For test mode \$02)
- Memorize the diagnosis value and trouble standard value. (For test mode \$06)

# DIAGNOSTIC TROUBLE CODE (DTC) DETECTING CRITERIA

## GENERAL DESCRIPTION

### AU:DTC P0420 — CATALYST SYSTEM EFFICIENCY BELOW THRESHOLD (BANK 1) —

#### 1. OUTLINE OF DIAGNOSIS

Check the catalyst efficiency deterioration.

Generally, the catalytic converter exhaust gas conversion efficiency and oxygen absorbing/removing function are inter-related. The front A/F sensor and rear oxygen sensor are therefore utilized to monitor the oxygen absorbing/removing function, and the results are used to monitor the conversion efficiency.

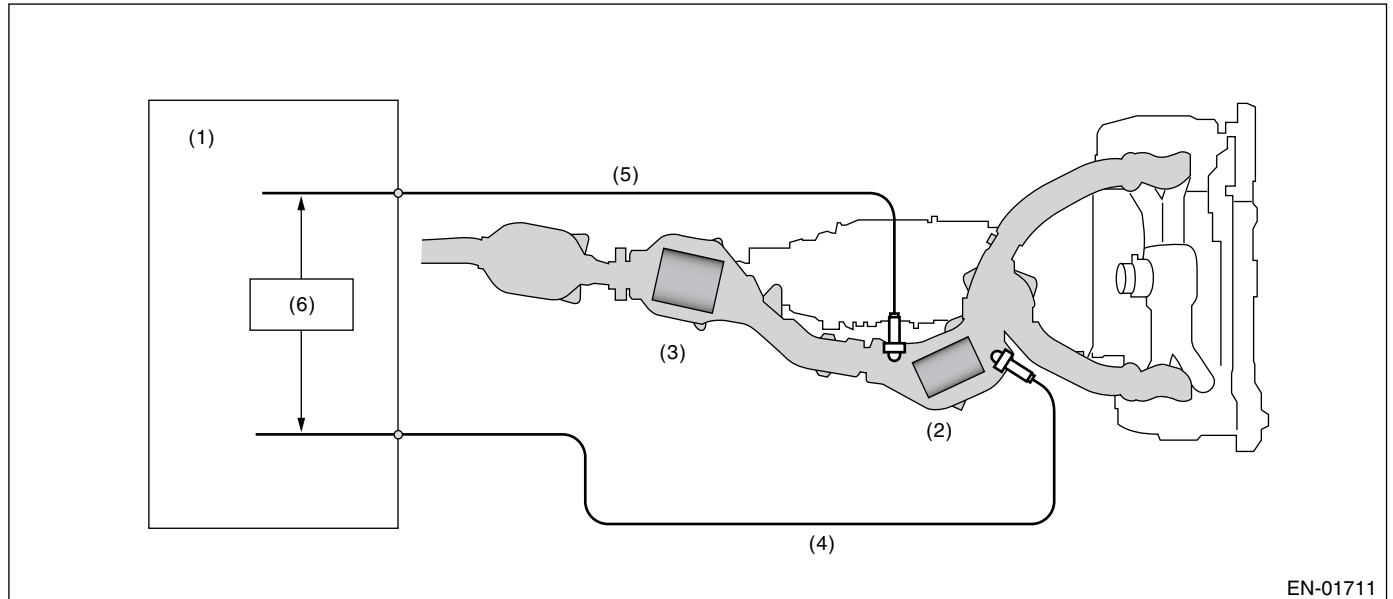

EN-01711

(1) Engine control module (ECM)

(3) Rear catalyst converter

(5) Rear oxygen sensor

(2) Front catalyst converter

(4) Front oxygen (A/F) sensor

(6) Diagnosis circuit



# DIAGNOSTIC TROUBLE CODE (DTC) DETECTING CRITERIA

GENERAL DESCRIPTION

Oil adherence to the catalytic metal (an alloy of platinum and rhodium, or an alloy of platinum, rhodium and palladium) in catalyst converter or metal melting by extraordinary high temperature result in the decrease of metal surface area contacting exhaust gas. Eventually, catalytic conversion efficiency blunted and oxygen density of catalyst downstream may change.

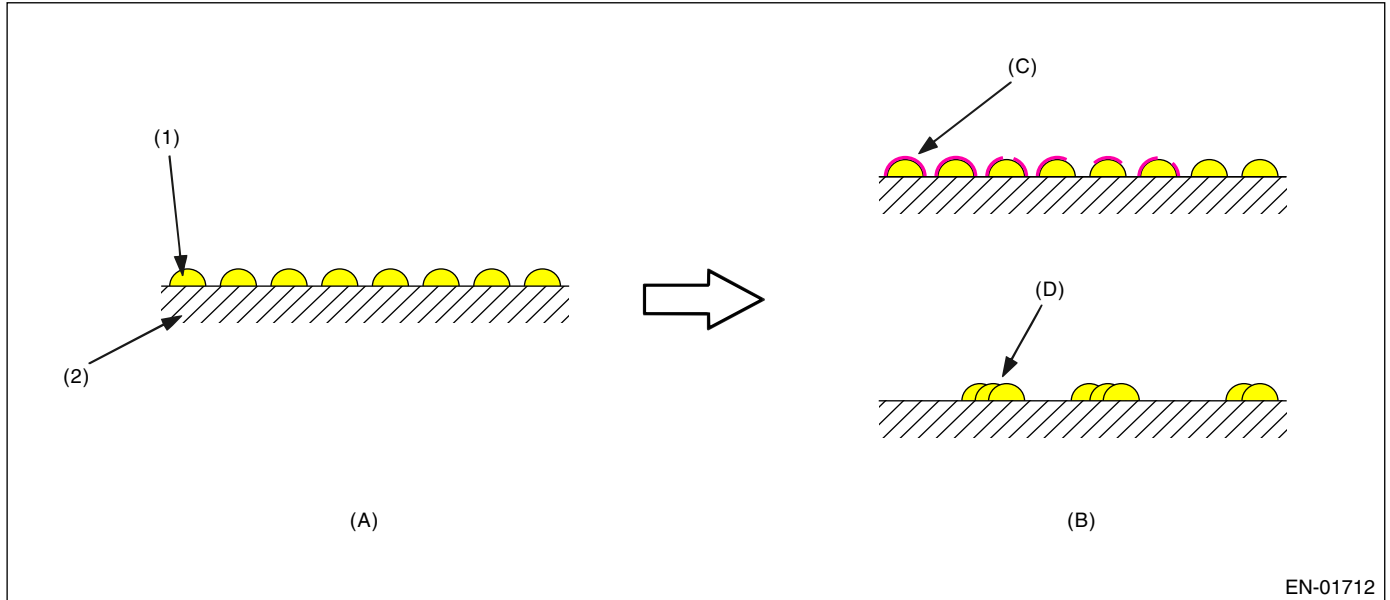

EN-01712

- (1) Metal (catalytic function)
- (2) Monolith

- (A) Normal
- (B) Deterioration

- (C) Oil adherence
- (D) Metal melting by high temperature

Output of rear oxygen sensor changes gradually with a new catalyst, but the blunted catalyst efficiency mentioned above makes sensor output larger and inverse time shorter.

Therefore, catalyst diagnosis is conducted by monitoring the rear oxygen sensor output and comparing its output with the front A/F sensor output.

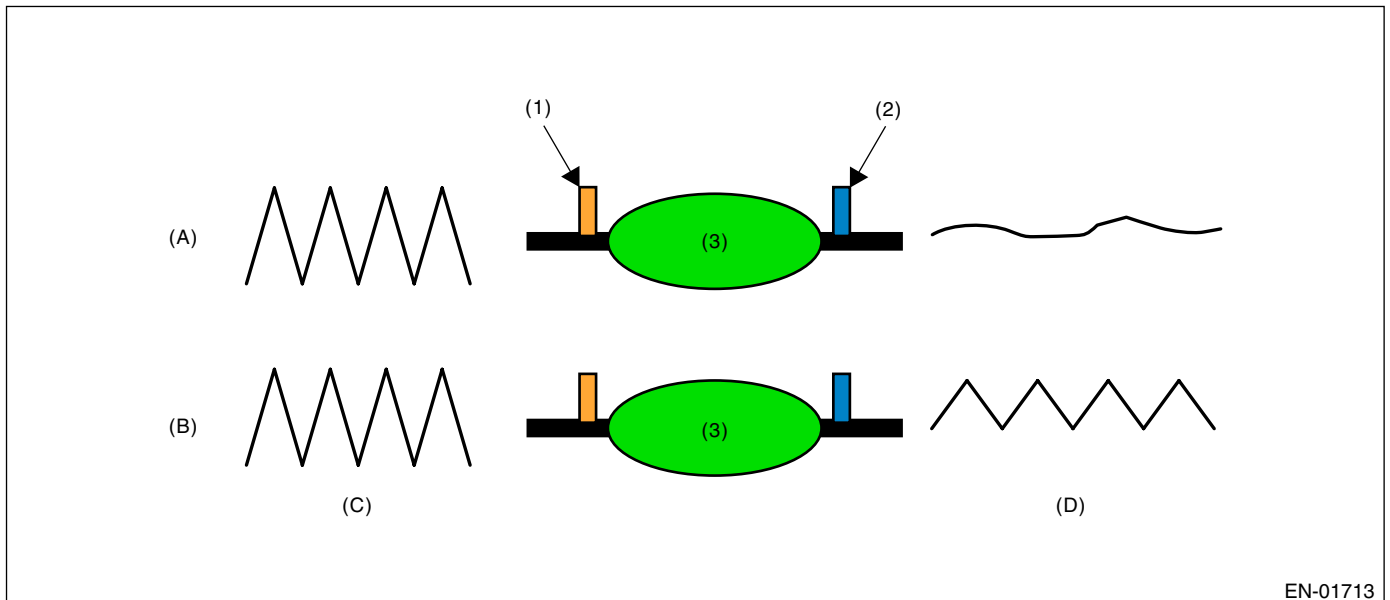

EN-01713

- (1) Front oxygen (A/F) sensor
- (2) Rear catalyst converter
- (3) Catalytic converter

- (A) Normal
- (B) Deterioration
- (C) Output waveform from the front oxygen (A/F) sensor

- (D) Output waveform from the rear oxygen sensor

# DIAGNOSTIC TROUBLE CODE (DTC) DETECTING CRITERIA

## GENERAL DESCRIPTION

### 2. ENABLE CONDITION

Secondary Parameters	Enable Conditions
Idle switch off after coolant temp 71°C (160°F)	180 seconds
Closed loop control continuous 5 seconds	Not in standstill
Vehicle speed	24 — 140 km/h (15 — 87 MPH)
Injector pulse (AT)	0.832 — 4.096 milliseconds
(MT)	0.384 — 3.840 milliseconds
Closed loop control rear oxygen sensor	In operation
Engine misfire during 400 ignitions	≤ 5 times
Lambda	0.625 — 1.375
Engine speed (AT)	600 — 3000 rpm
(MT)	1000 — 3300 rpm
Neutral position	OFF
Engine coolant temperature	≥ 75°C (167°F)
Throttle position (AT)	< 14.72°
(MT)	< 17.60°
Average AIA during diagnosis	≥ 27.0 kg (60 lb)/h
Integrated fluctuating AIA during diagnosis	> 160 kg (353 lb)/h
After fuel shut-off finished	1 seconds or more
Accumulated amount of intake air (AIA) (start condition)	0.84 kg (1.85 lb)/60 seconds
Vehicle speed (continuous 80 seconds) (start condition)	≥ 20 km/h (12 MPH)
Injector pulse (continuous 40 seconds) (start condition)	1.34 — 4.22 milliseconds
Vehicle speed (continuous 70 seconds) (start condition)	≥ 74 km/h (46 MPH)

### 3. GENERAL DRIVING CYCLE

Perform the diagnosis once with a constant vehicle speed 74 km/h (40 MPH).

### 4. DIAGNOSTIC METHOD

#### • Output fluctuation accumulate method

The accumulated value of front A/F sensor output changes and the accumulated value of rear oxygen sensor output changes are determined, and the diagnostic value is calculated using the following formula.

Diagnostic value = Accumulated value of rear oxygen sensor output changes / Accumulated value of front A/F sensor output changes

# DIAGNOSTIC TROUBLE CODE (DTC) DETECTING CRITERIA

GENERAL DESCRIPTION

• For example

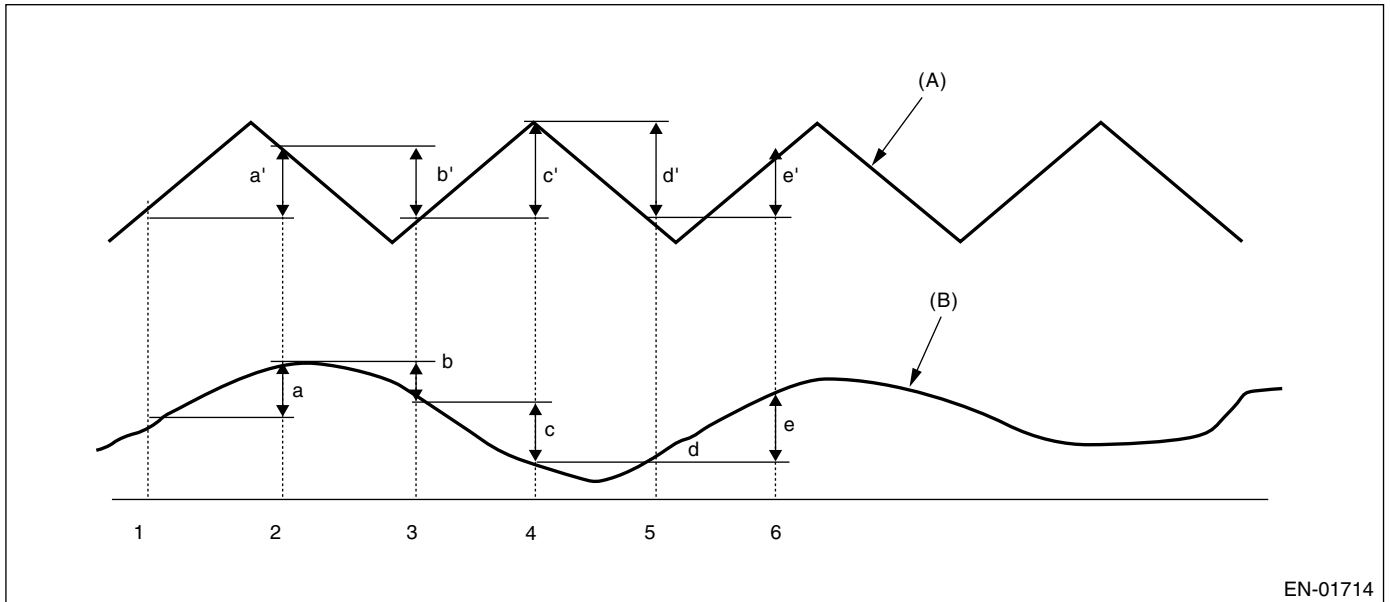

EN-01714

(A) Front oxygen (A/F) sensor output waveform

(B) Rear oxygen sensor output waveform

Judge NG when the malfunction criteria below are completed, and judge OK when they are not completed.

• Judgment Value

Malfunction Criteria	Threshold Value
Accumulated variation of output Voltage of rear oxygen sensor per 50 milliseconds divided by accumulated Variation of output voltage of front lambda sensor per 50 milliseconds	$\geq 1.4$

**Time Needed for Diagnosis:** 45 seconds

**Malfunction Indicator Light Illumination:** 2 continuous driving cycles.

## 5. DTC CLEAR CONDITION

- When the OK idling cycle is completed 40 times in a row
- When "Clear Memory" was performed

## 6. MALFUNCTION INDICATOR LIGHT CLEAR CONDITION

- When the OK driving cycle is completed 3 times in a row
- When "Clear Memory" was performed

## 7. FAIL SAFE

None

## 8. ECM OPERATION AT DTC SETTING

- Memorize the freeze frame data. (For test mode \$02)
- Memorize the diagnosis value and trouble standard value. (For test mode \$06)

# DIAGNOSTIC TROUBLE CODE (DTC) DETECTING CRITERIA

## GENERAL DESCRIPTION

### AV:DTC P0442 — EVAPORATIVE EMISSION CONTROL SYSTEM LEAK DETECTED (SMALL LEAK) —

#### 1. OUTLINE OF DIAGNOSIS

Check if there is a leakage in fuel system or not, and perform the function diagnosis of valve.

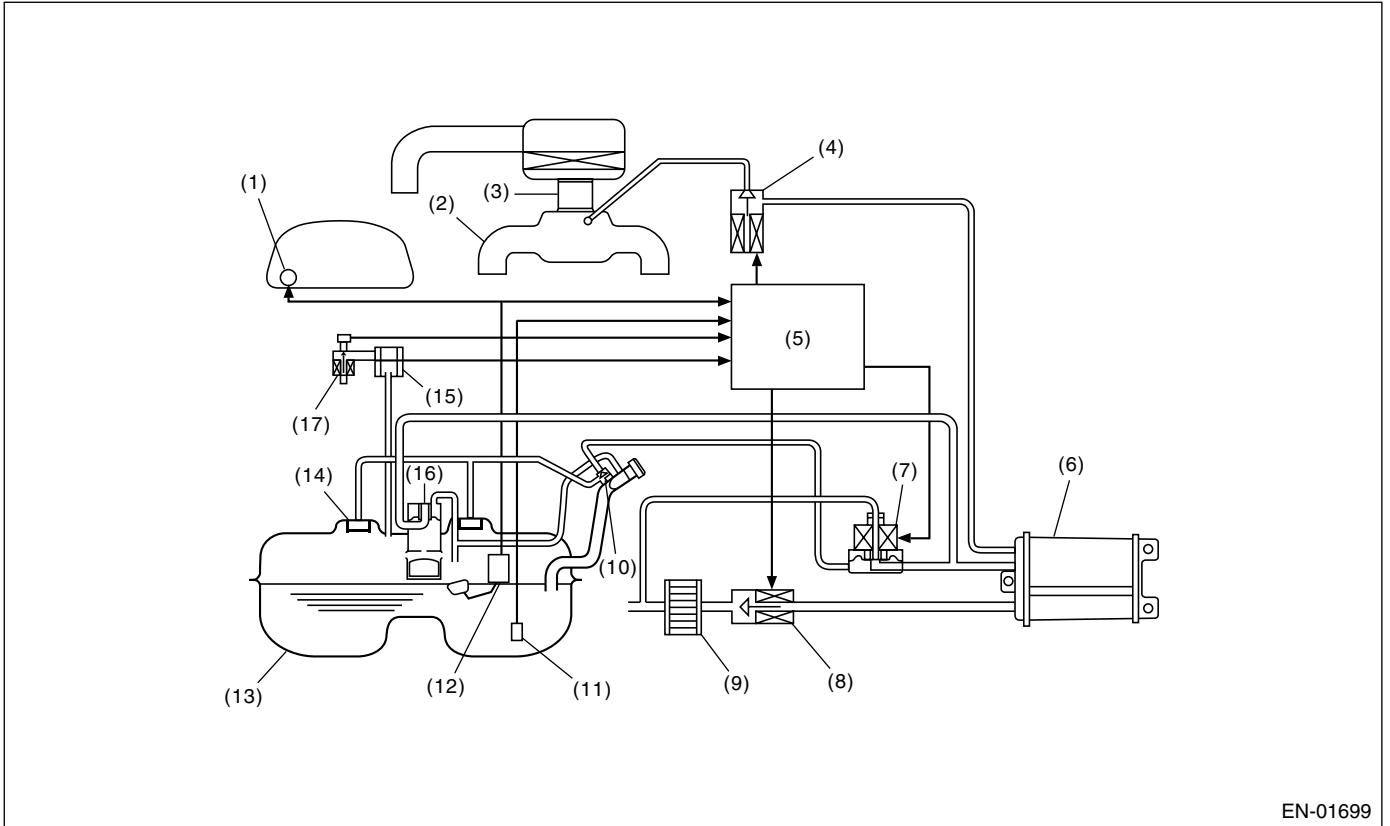

- |                                  |                                     |   |
|----------------------------------|-------------------------------------|---|
| (1) Fuel gauge                   | (7) Pressure control solenoid valve | (13) Fuel tank                              |
| (2) Intake manifold              | (8) CCV                             | (14) Fuel cut valve                         |
| (3) Throttle body                | (9) Drain filter                    | (15) Fuel tank pressure sensor              |
| (4) Purge control solenoid valve | (10) Shut-off valve                 | (16) Vent valve                             |
| (5) Engine control module (ECM)  | (11) Fuel temperature sensor        | (17) Tank pressure switching solenoid valve |
| (6) Canister                     | (12) Fuel level sensor              |   |

In this system diagnosis, checking for leakage and valve function is conducted by changing the fuel tank pressure, and monitoring the pressure change using the fuel tank pressure sensor. 0.04 inch diagnosis is performed in the order of mode Z, mode A, mode B, mode C, mode D and mode E, and 0.02 inch diagnosis is performed in the order of mode Y, mode A, mode B, mode C, mode D and mode E.

# DIAGNOSTIC TROUBLE CODE (DTC) DETECTING CRITERIA

GENERAL DESCRIPTION

## • 0.04-inch Diagnosis

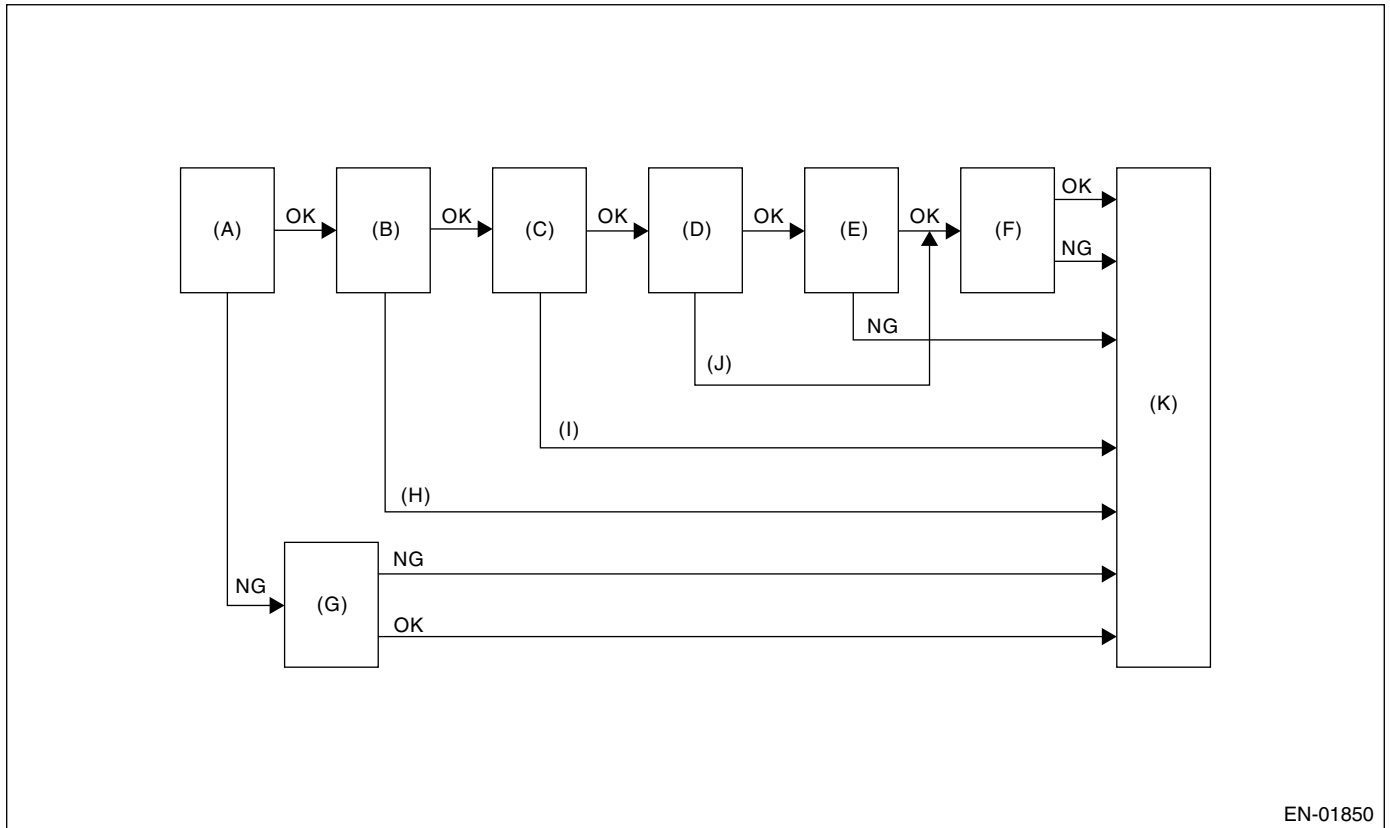

EN-01850

- |            |                   |                             |
|------------|-------------------|-----------------------------|
| (A) Mode Z | (E) Mode D        | (I) Large leakage judgement |
| (B) Mode A | (F) Mode E        | (J) Early OK                |
| (C) Mode B | (G) Mode Z Extend | (K) END                     |
| (D) Mode C | (H) Cancel        |                             |

Mode	Mode Description	Diagnosis Period
Mode Z (CCV abnormal close diagnosis)	Carry out CCV close trouble diagnosis according to tank pressure change amount after the diagnosis has started.	3 — 16 seconds
Mode A (Estimated evaporation amount)	Calculate the tank pressure change amount (P1).	7 — 15.5 seconds
Mode B (Sealed negative pressure, large leakage judgment)	Introduce the intake manifold pressure to the fuel tank and reduce the tank pressure to the desired value. If the tank pressure cannot be reduced, it is diagnosed as large leakage.	5 — 35 seconds
Mode C (Pressure increase check, advanced OK judgment)	Wait until the tank pressure becomes P2 calculation start pressure. If the tank pressure does not become the value, make advanced OK judgment.	4 — 16 seconds
Mode D (Negative pressure variation measurement, evaporation leakage diagnosis)	Calculate the tank pressure variation (P2), and obtain the diagnostic value using P1 of Mode 1. Perform the evaporation leakage diagnosis using the diagnostic value.	7 — 15.5 seconds
Mode E (CCV property abnormal diagnosis)	Perform the CCV property abnormal diagnosis according to the tank pressure change amount after the leakage diagnosis has finished.	4 seconds

# DIAGNOSTIC TROUBLE CODE (DTC) DETECTING CRITERIA

## GENERAL DESCRIPTION

### • 0.02-inch Diagnosis

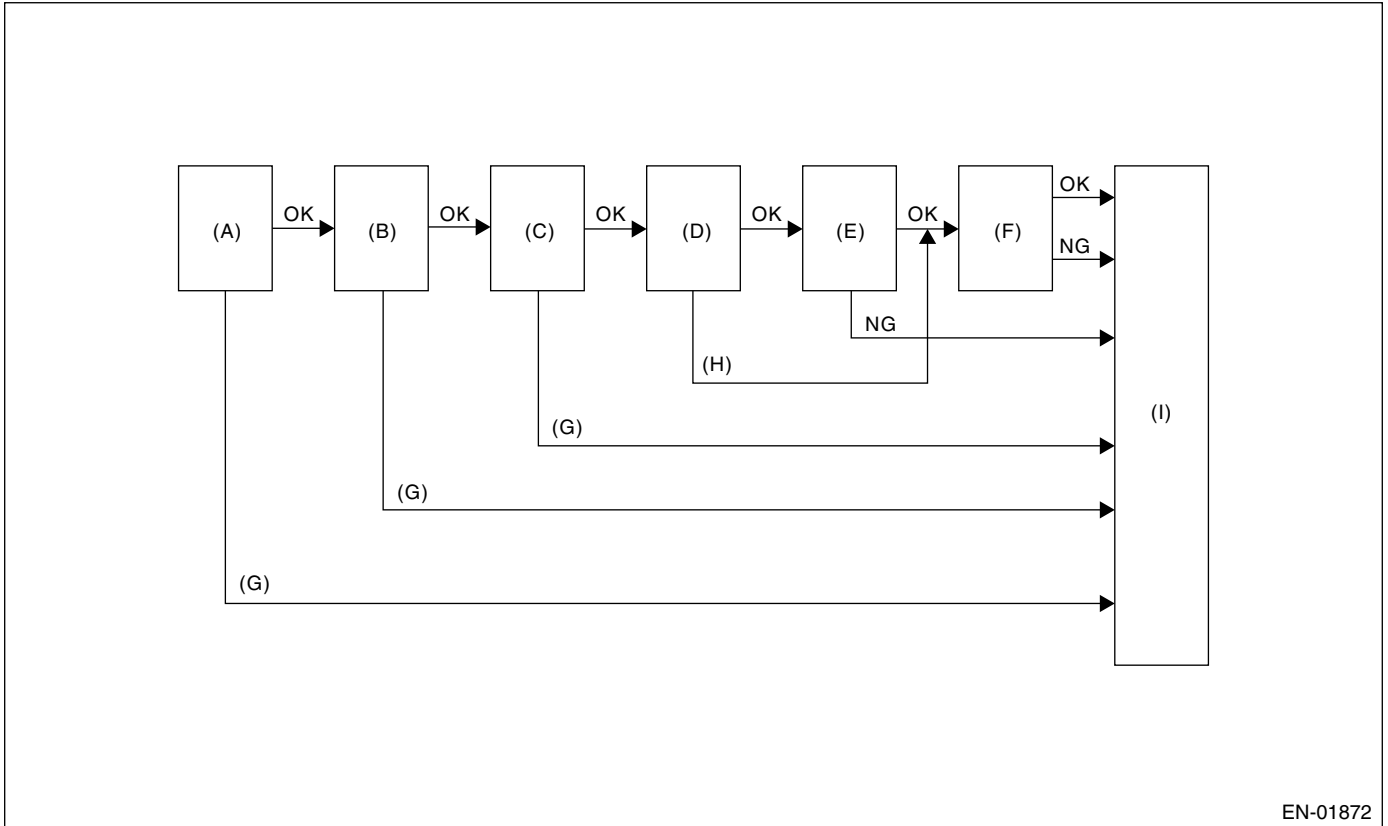

EN-01872

(A) Mode Y  
(B) Mode A  
(C) Mode B

(D) Mode C  
(E) Mode D  
(F) Mode E

(G) Cancel  
(H) Early OK  
(I) END

Mode	Mode Description	Diagnosis Period
Mode Y (Tank pressure stabilization)	Return the tank pressure to atmosphere.	0.1 seconds
Mode A (Estimated evaporation amount)	Calculate the tank pressure change amount (P1).	26 seconds
Mode B (Negative pressure sealed)	Introduce the intake manifold pressure to the fuel tank and reduce the tank pressure to the desired value.	10 — 62 seconds
Mode C (Pressure increase check, advanced OK judgment)	Wait until the tank pressure becomes P2 calculation start pressure. If the tank pressure does not become the value, make advanced OK judgment.	5 — 20 seconds
Mode D (Negative pressure variation measurement, evaporation leakage diagnosis)	Calculate the tank pressure variation (P2), and obtain the diagnostic value using P1 of Mode 1. Perform the evaporation leakage diagnosis using the diagnostic value.	22 seconds
Mode E (CCV property abnormal diagnosis)	Perform the CCV property abnormal diagnosis according to the tank pressure change amount after the leak diagnosis has finished.	4 seconds

# DIAGNOSTIC TROUBLE CODE (DTC) DETECTING CRITERIA

GENERAL DESCRIPTION

## • Mode Table for Evaporative Emission Control System Diagnosis

### • 0.04-inch Diagnosis

Mode	Behavior of tank internal pressure under normal conditions	Diagnostic item	DTC
Mode Z	Nearly same as atmospheric pressure (equivalent pressure of 0 kPa (0 mmHg, 0 inHg))	CCV is judged to be stuck closed.	P1443
Mode A	Pressure is in proportion to amount of evaporation gas occurrence.		
Mode B	Negative pressure is formed due to intake manifold negative pressure	Large leakage judgment	P0457
Mode C	Target pressure is reached.		
Mode D	Pressure change is small.	Evaporation system is judged to have large leak [1.0 mm (0.04 in)].	P0442
Mode E	Return to atmosphere	CCV property judgment	P1443

### • 0.02-inch Diagnosis

Mode	Behavior of tank internal pressure under normal conditions	Diagnostic item	DTC
Mode Y	Return to atmosphere		
Mode A	Pressure is in proportion to amount of evaporation gas occurrence.		
Mode B	Negative pressure is formed due to intake manifold negative pressure		
Mode C	Target pressure is reached.		
Mode D	Pressure change is small.	P2 measurement of small leak in system. Evaporation system is judged to have small leak [0.5 mm (0.02 in)].	P0456
Mode E	Return to atmosphere	CCV property judgment	P1443

# DIAGNOSTIC TROUBLE CODE (DTC) DETECTING CRITERIA

## GENERAL DESCRIPTION

### 2. COMPONENT DESCRIPTION

#### • Pressure Control Solenoid Valve

PCV controls the fuel tank pressure to be equal to the atmospheric air pressure.

Normally, the solenoid is set to OFF. And the valve opens and closes mechanically in accordance with the pressure difference between tank and atmospheric air, or tank and canister.

Also the valve is able to forcibly opened by setting the solenoid to ON.

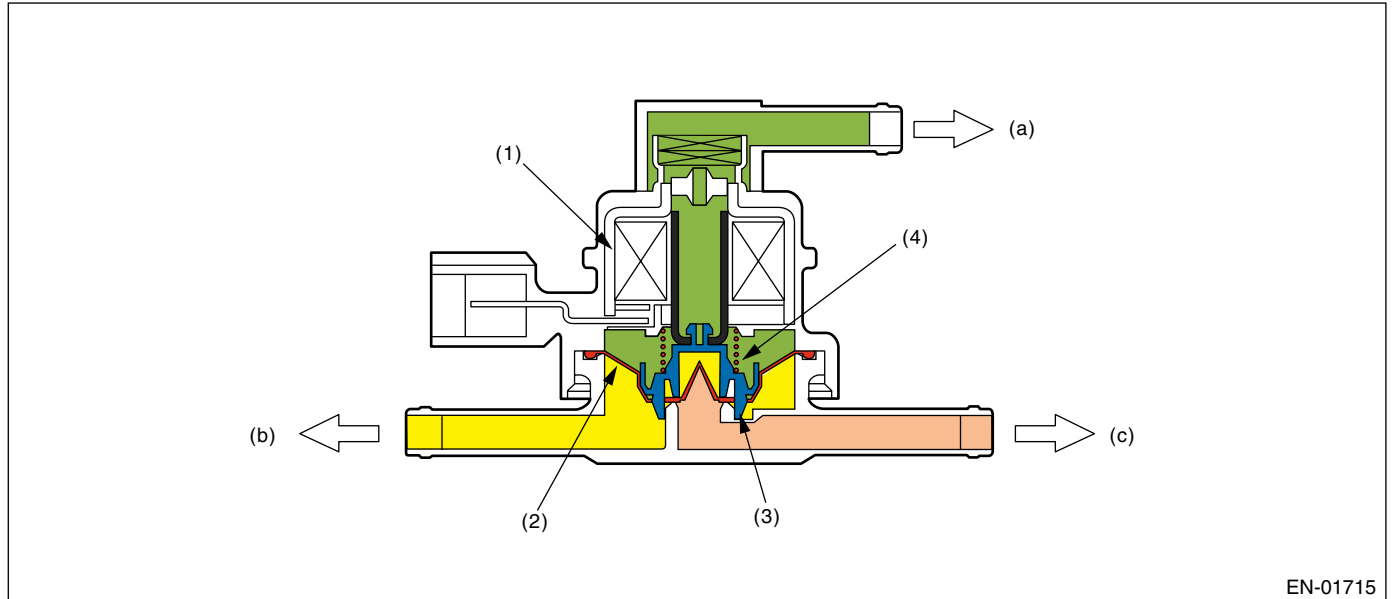

(1) Solenoid  
(2) Diaphragm

(3) Valve  
(4) Spring

(a) Atmospheric pressure  
(b) Fuel tank  
(c) Canister



# DIAGNOSTIC TROUBLE CODE (DTC) DETECTING CRITERIA

GENERAL DESCRIPTION

## • Valve Operation and Air Flow

In the figure below, divided by the diaphragm, the part above X is charged with atmospheric air pressure, and the part below X is charged with tank pressure. Also, the part above Y is charged with tank pressure, and the part below Y is charged with canister pressure.

If the atmospheric air pressure port is A, tank pressure port is B, and canister pressure port is C, the air flows according to pressure difference from each port as shown in the table below.

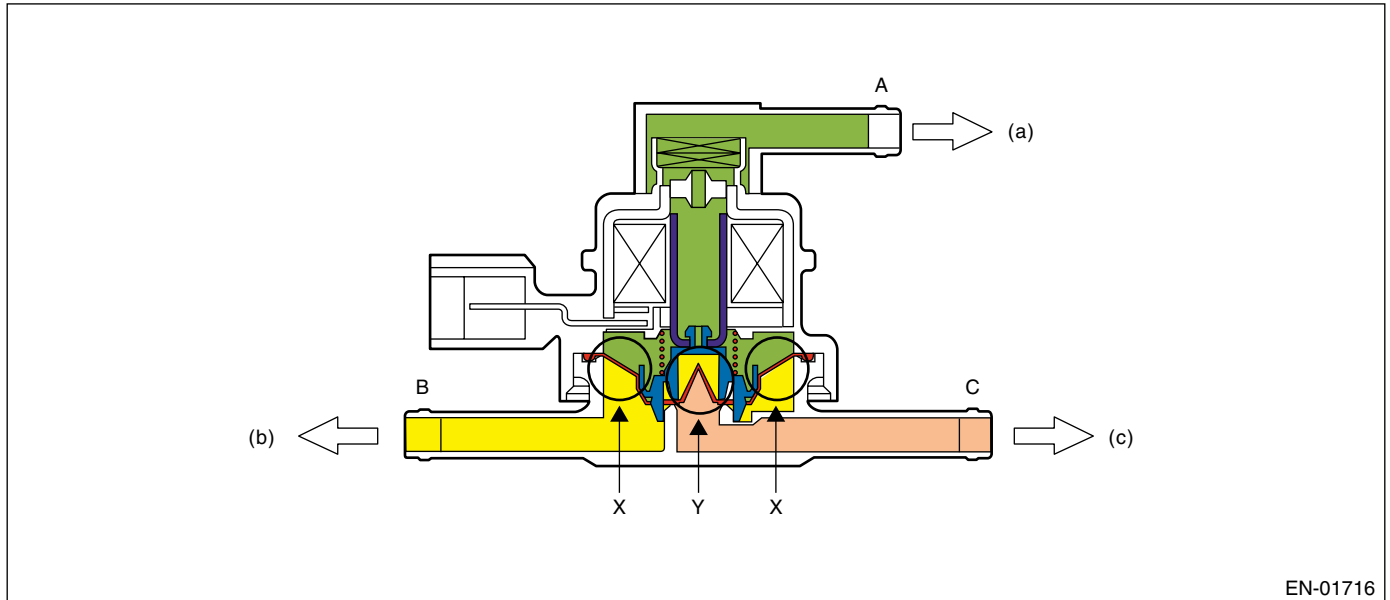

EN-01716

(a) Atmospheric pressure

(b) Fuel tank

(c) Canister

Condition of pressure	Flow
$A < B$ (solenoid OFF)	$B \rightarrow C$
$B < C$ (solenoid OFF)	$C \rightarrow B$
Solenoid ON	$B \leftrightarrow C$

## • When $A < B$ (Solenoid OFF)

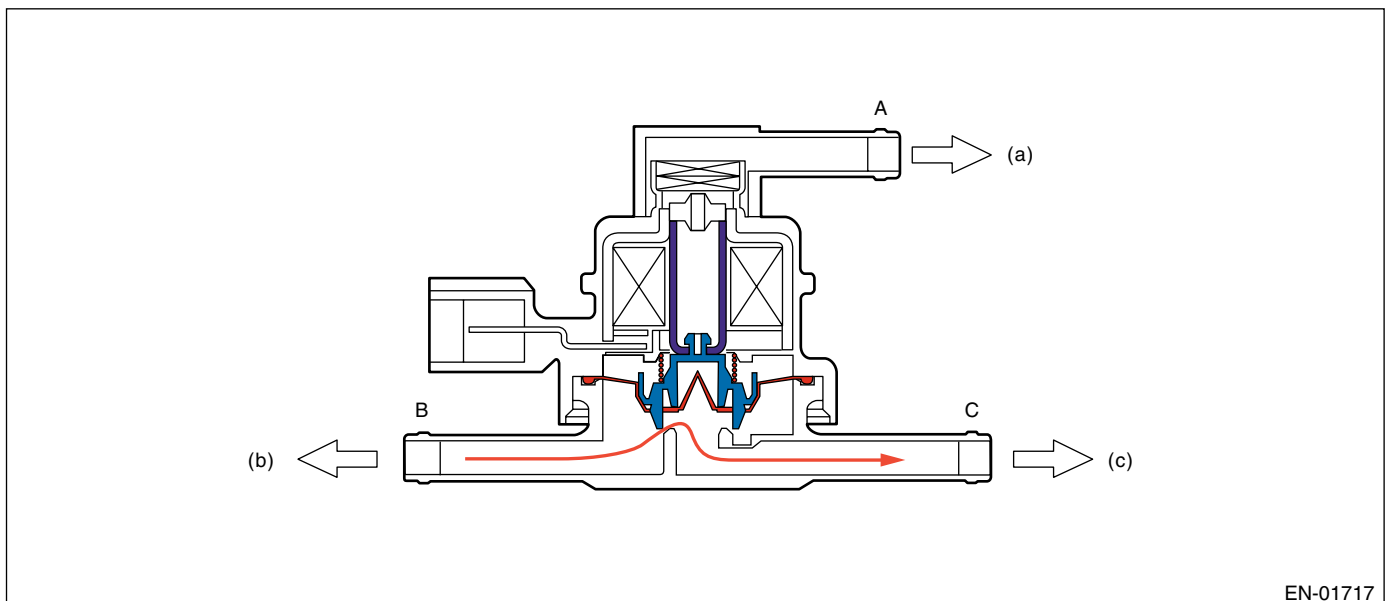

EN-01717

(a) Atmospheric pressure

(b) Fuel tank

(c) Canister

# DIAGNOSTIC TROUBLE CODE (DTC) DETECTING CRITERIA

## GENERAL DESCRIPTION

### • When $B < C$ (Solenoid OFF)

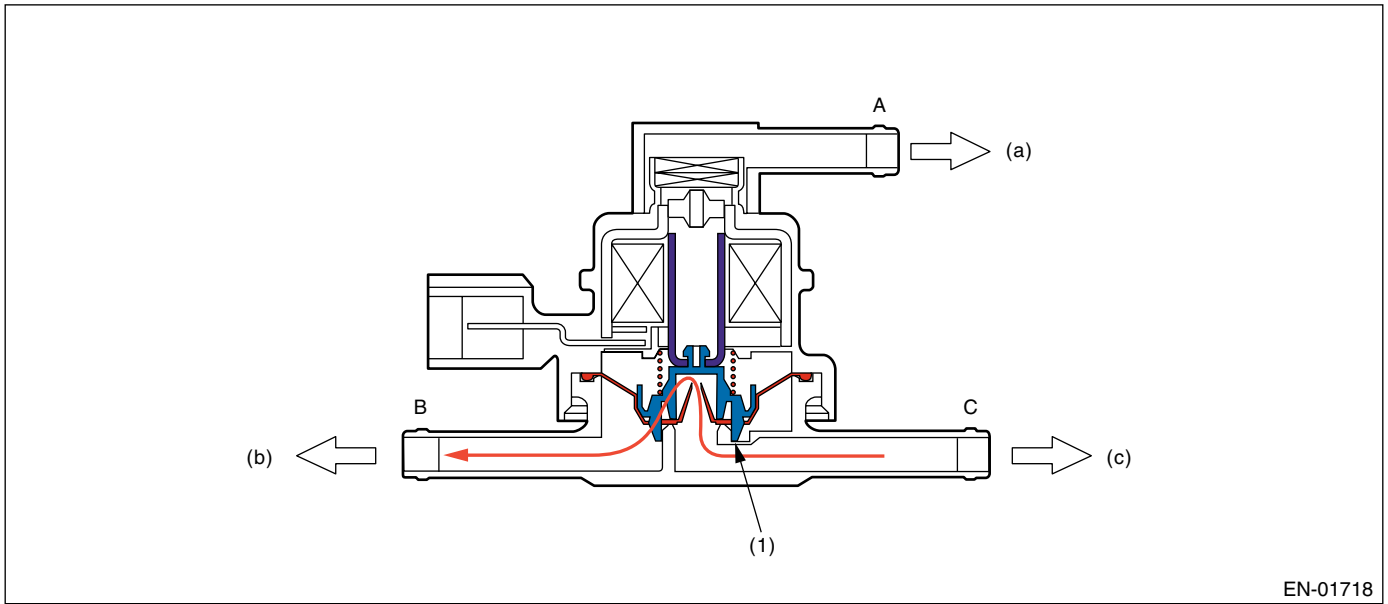

(1) Atmospheric pressure

(a) Atmospheric pressure

(b) Fuel tank

(c) Canister

### • When Solenoid is ON

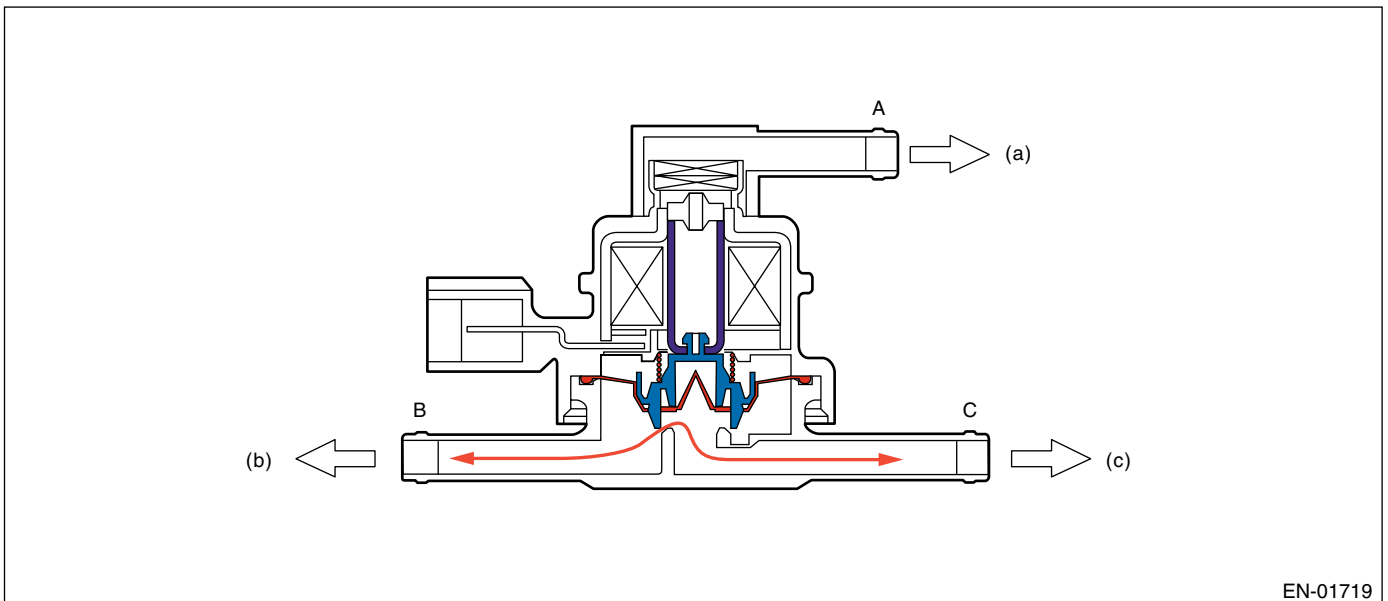

(a) Atmospheric pressure

(b) Fuel tank

(c) Canister

# DIAGNOSTIC TROUBLE CODE (DTC) DETECTING CRITERIA

GENERAL DESCRIPTION

## • CCV

In normal condition, drain valve opens when solenoid is turning OFF, and the solenoid is turned ON when diagnosis and the valve close.

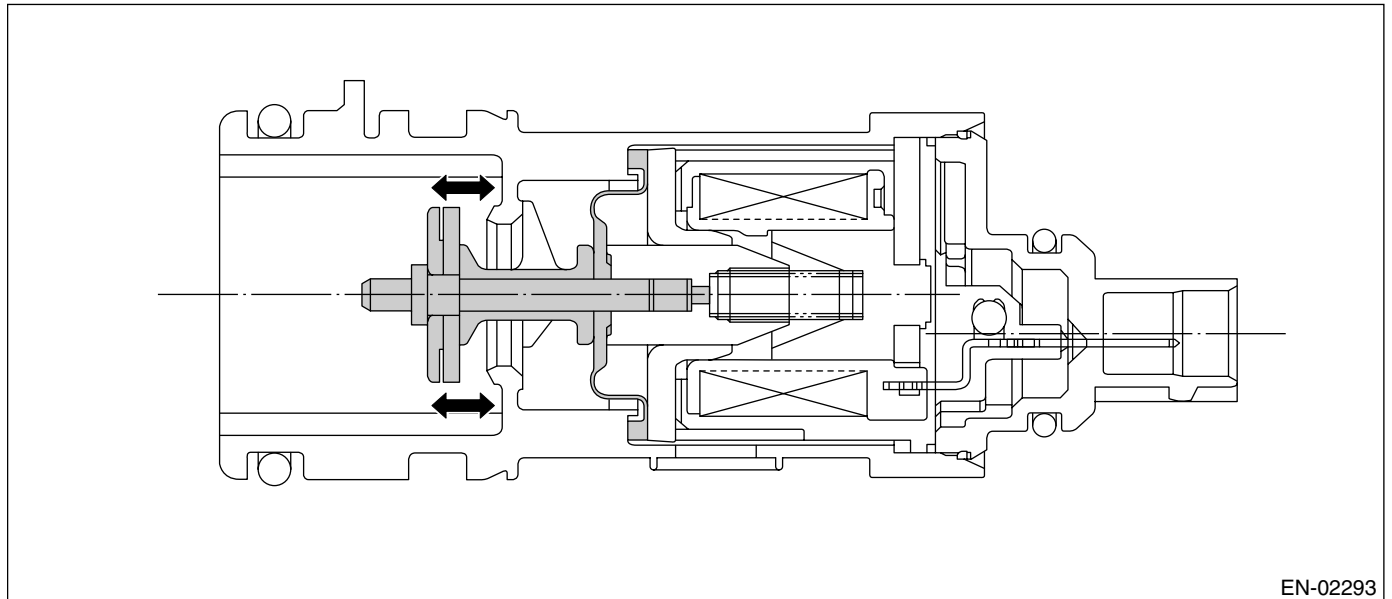

## • Tank Pressure Switching Solenoid

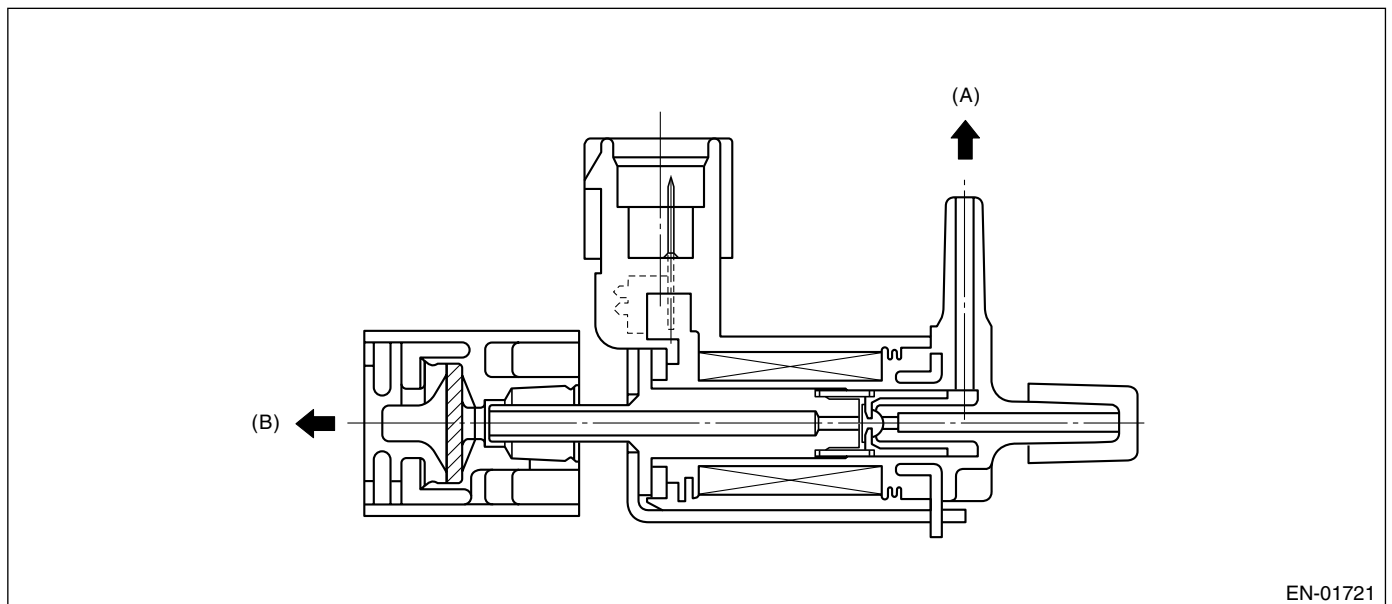

(A) Fuel tank pressure sensor

(B) Atmosphere

# DIAGNOSTIC TROUBLE CODE (DTC) DETECTING CRITERIA

## GENERAL DESCRIPTION

### • Purpose of this solenoid

Fuel tank pressure sensor detects the difference between the atmospheric air pressure and the tank pressure and the ECM monitors the pressure difference.

Even if the tank pressure is constant, the atmospheric air pressure varies depending on the driving height, and the pressure signal transmitted to ECM will change.

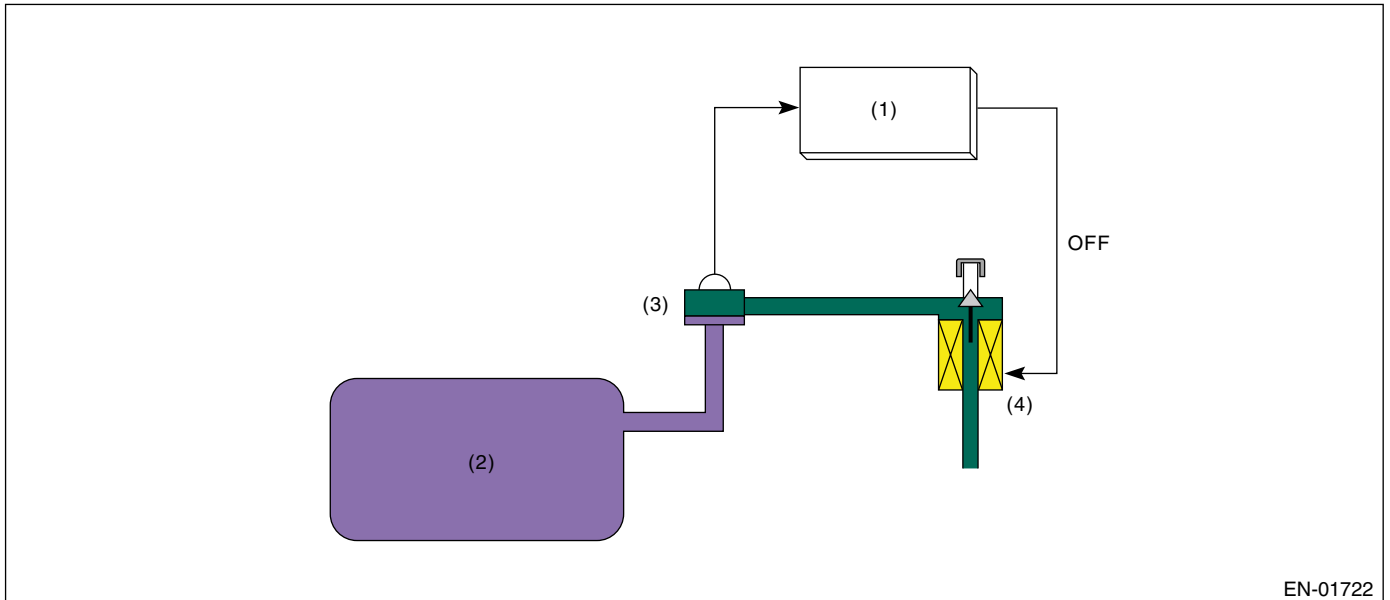

EN-01722

- (1) Engine control module (ECM)
- (2) Fuel tank
- (3) Fuel tank pressure sensor

- (4) Atmospheric pressure switching solenoid

# DIAGNOSTIC TROUBLE CODE (DTC) DETECTING CRITERIA

GENERAL DESCRIPTION

Especially, in the small leakage [0.5 mm (0.02 in)], minute change in the tank pressure has to be detected. This diagnosis period is long (approx. 29 seconds). And if the driving height changes during the diagnosis, the atmospheric air pressure changes. In this case, it becomes difficult to precisely detect the tank pressure variation, causing erroneous diagnosis. Therefore, using the atmospheric pressure switching solenoid, atmospheric air is sealed between the fuel tank pressure sensor and atmospheric pressure switching solenoid, maintaining the air pressure constant and enabling the detection of minute variation of tank pressure.

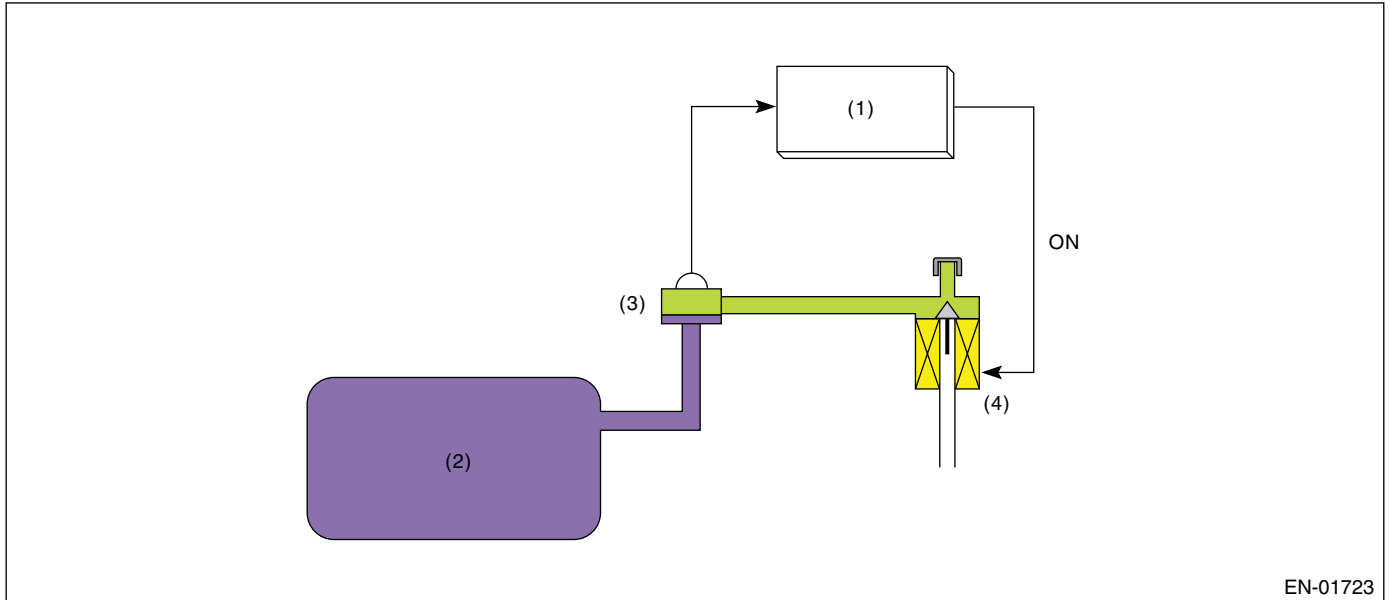

EN-01723

- |                                 |   |
|---------------------------------|---|
| (1) Engine control module (ECM) | (3) Fuel tank pressure sensor               |
| (2) Fuel tank                   | (4) Atmospheric pressure switching solenoid |

## NOTE:

ECM also has the atmospheric air pressure sensor, and always monitors atmospheric air. However, as the monitoring range is large, that is, 53 to 107 kPa (400 to 800 mmHg, 16 to 32 inHg) it is not suitable for detection of minute pressure variation.

In the case of small leakage diagnosis, the tank pressure variation is very small, that is, 0.13 to 0.27 kPa (1 to 2 mmHg, 0.04 to 0.08 inHg) and the fuel tank pressure sensor is equipped.

# DIAGNOSTIC TROUBLE CODE (DTC) DETECTING CRITERIA

## GENERAL DESCRIPTION

### 3. ENABLE CONDITION

#### 0.04-inch Diagnosis

Secondary Parameters	Enable Conditions
Closed air fuel ratio	In operation
Throttle angle	0.96 — 14.08°
Canister purge cumulative time	≥ 120 seconds
Engine speed	≥ 1500 rpm
Fuel tank pressure at Evap. monitoring starting	≥ -1.0 — 1.6 kPa (-7.5 — 12 mmHg, -0.295 — 0.472 inHg)
Intake manifold relative pressure	≤ -26.7 kPa (-200 mmHg, -7.87 inHg)
Vehicle speed	≥ 48 km/h (30 MPH)
Fuel level	9.6 — 48 ℓ (2.54 — 10.68 US gal, 2.11 — 10.56 Imp gal)
After engine started	More than 454 seconds
Barometric pressure	≥ 75.7 kPa (568 mmHg, 22.36 inHg)
Fuel temperature	-10 — 45°C (14 — 113°F)

#### Cancel Conditions

Secondary Parameters	Enable Conditions
Change of fuel level	≥ 5 ℓ (1.3 US gal, 1.1 Imp gal)/200 milliseconds
Throttle angle	≤ 0.640°
Engine speed	≤ 1300 rpm
Intake manifold relative pressure	≤ -16 kPa (-120 mmHg, -4.7 inHg)
Vehicle speed	≤ 48 km/h (30 MPH)
Compensation factor of air fuel ratio	≤ -30%
Tank pressure variation amount	≥ 0.1 kPa (0.75 mmHg, 0.03 inHg)
Pressure difference between max. and min. per 1 second while monitoring	< 0.09 kPa (0.656 mmHg, 0.026 inHg)
Time after finishing the previous 0.04-inch leakage diagnosis	> 180 seconds

# DIAGNOSTIC TROUBLE CODE (DTC) DETECTING CRITERIA

GENERAL DESCRIPTION

## 0.02-inch Diagnosis

Secondary Parameters	Enable Conditions
Continuous time of completing the all conditions below.	≥ 5 seconds
Fuel tank pressure at vacuum starting	0 — 1.26 kPa (0 — 9.45 mmHg, 0 — 0.0372 inHg)
Since last incomplete diagnosis event of 0.02 inches leak	> 180 seconds
Total time of operating canister purge	More than 120 seconds
After engine started	More than 325 seconds
Fuel tank pressure below -3050 Pa (-22.87 mmHg, -0.9007 inHg) during same driving cycle	< 2 times
Fuel temperature	-10 — 35°C (14 — 95°F)
After engine start with coolant temperature of 40°C or below	< 2400 seconds
Fuel level	96 — 48 ℓ (2.54 — 10.68 US gal, 2.11 — 10.56 Imp gal)
Atmospheric pressure	≥ 75.7 kPa (568 mmHg, 22.3 inHg)
Ambient temperature	≥ -10°C (14°F)
(Ambient-fuel) temperature	< 1°C (34°F)
Closed air fuel ratio control	In operation

## Cancel Conditions

Secondary Parameters	Enable Conditions
Lambda factor	< 0.75
P1	≥ 125 Pa (0.94 mmHg, 0.04 inHg)
P1	< -87.5 kPa (-0.66 mmHg, -0.03 inHg)
Change of fuel level	≥ 3.5 ℓ (3.7 US gal, 3.1 Imp gal)
Pressure difference between max. and min. per 1 second while monitoring	≥ 87.5 Pa (0.62 mmHg, 0.024 inHg)
Change of atmospheric pressure during calculation of P1	≥ 137.5 kPa (0.97 mmHg, 0.038 inHg)
Change of atmospheric pressure during calculation of P2	≥ 225 Pa (1.58 mmHg, 0.062 inHg)
Change of fuel level after engine starting (8 ℓ or more)	≤ 0 times
Change of engine speed after starting the diagnosis	≥ 600 rpm
Change of manifold absolute pressure after starting the diagnosis	≥ 40.0 kPa (300 mmHg, 11.81 inHg)

# DIAGNOSTIC TROUBLE CODE (DTC) DETECTING CRITERIA

## GENERAL DESCRIPTION

---

### 4. GENERAL DRIVING CYCLE

#### • 0.04-inch Diagnosis

- Perform the diagnosis only once in more than 454 seconds after the engine start at the constant driving speed of 48 km/h (30 MPH) or more.
- Pay attention to the fuel temperature and fuel level.

#### • 0.02-inch Diagnosis

- Perform diagnosis in more than 325 seconds after engine start at the constant speed of 68 km/h (42 MPH) or more, and then terminate the diagnosis when judged OK or NG.
- If not judged OK or NG, repeat the diagnosis until judged OK or NG.
- Pay attention to the fuel temperature and fuel level.

### 5. DIAGNOSTIC METHOD

#### • MODE Y (Tank pressure stabilization)

Perform the diagnosis under the conditions, and return the tank pressure to atmosphere.

Tank pressure > 0.9 kPa (67.5 mmHg, 2.7 inHg) after 0.1 seconds:

Cancel the leak check. (Change to Mode A, Tank pressure ≤ 0.9 kPa (67.5 mmHg, 2.7 inHg).)

#### • MODE Z (Purge control solenoid valve open malfunction diagnosis, CPC close malfunction diagnosis)

DTC P0457

DTC P1443

#### • Purpose of Mode Z

When performing the leakage diagnosis of EVAP system, CCV and CPC have to operate normally. Therefore, mode Z is used to diagnose the CCV close fixation and CPC open fixation.

If the CCV closed fixation trouble or CPC open fixation trouble is detected, the EVAP system leakage diagnosis is cancelled.

If the CCV closed fixation trouble occurred, negative pressure is generated from the engine to pressure control solenoid valve when pressure control solenoid valve is closed and CPC is opened. Under this condition, the valve cannot be opened for the pressure control solenoid valve structure if the negative pressure is larger than electromagnetic force when pressure control solenoid valve solenoid is set to ON in order to open the valve.



# DIAGNOSTIC TROUBLE CODE (DTC) DETECTING CRITERIA

GENERAL DESCRIPTION

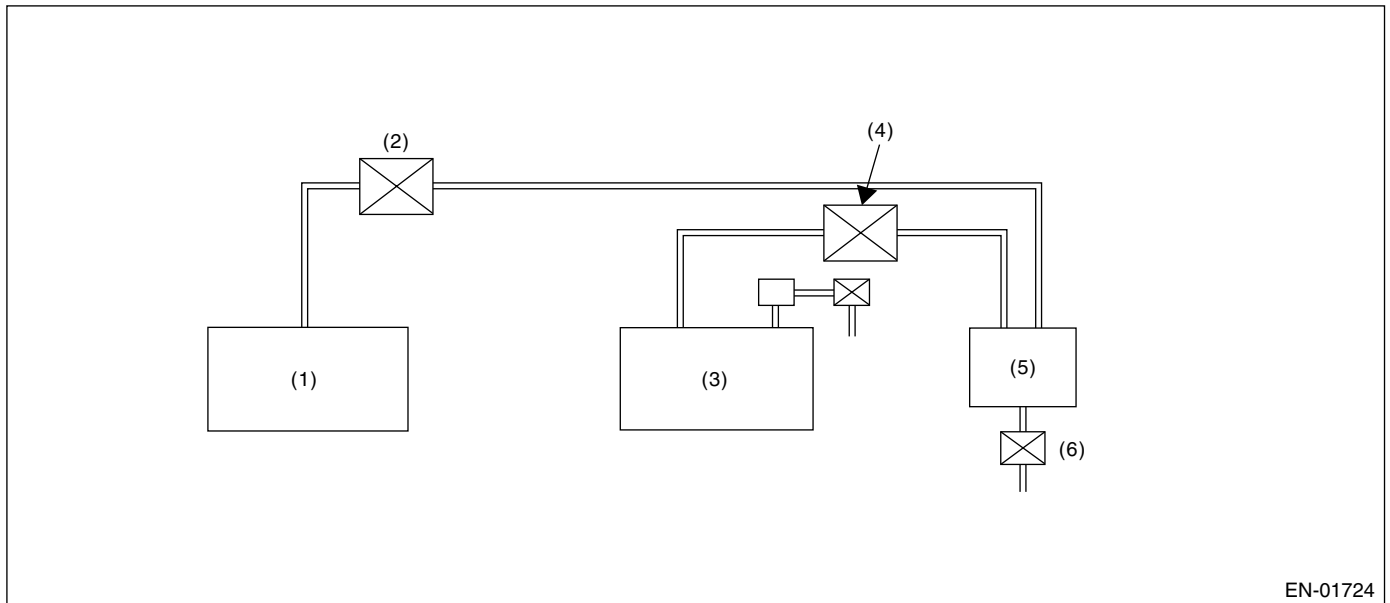

EN-01724

- |                                       |   |                     |
|---------------------------------------|---|---------------------|
| (1) Engine                            | (3) Fuel tank                             | (5) Canister        |
| (2) Purge control solenoid valve open | (4) Pressure control solenoid valve close | (6) CCV stuck close |

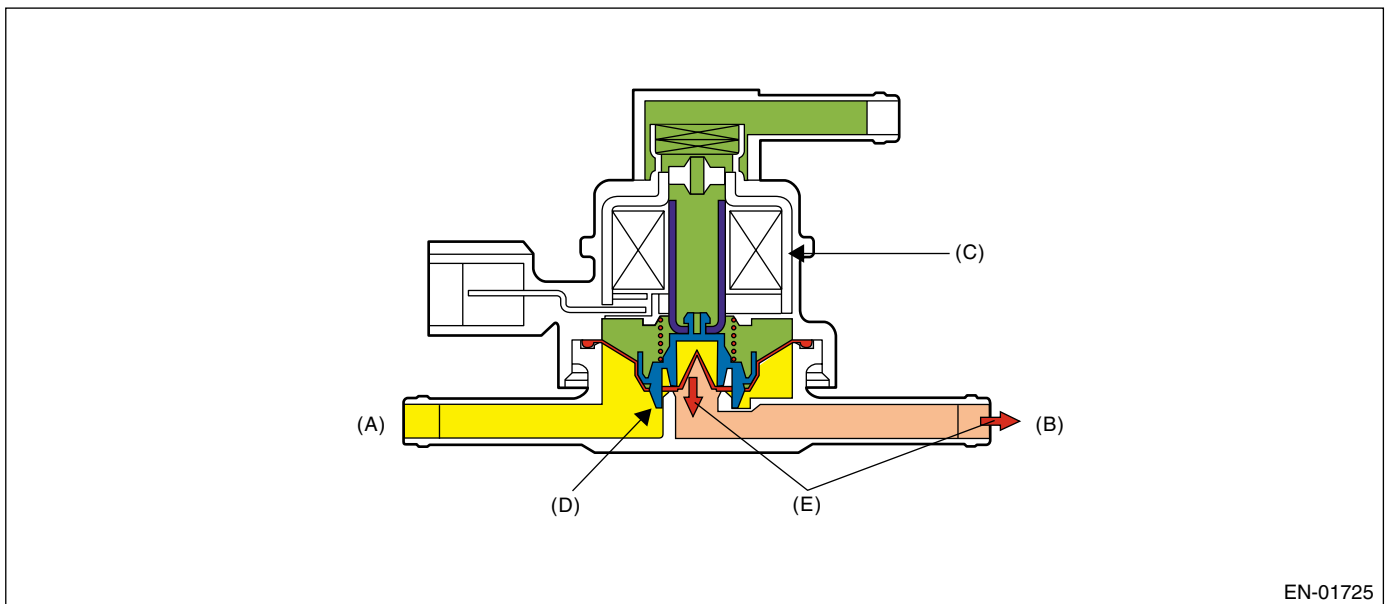

EN-01725

- |                                     |                           |                       |
|-------------------------------------|---------------------------|-----------------------|
| (A) To fuel tank                    | (C) Solenoid ON           | (E) Negative pressure |
| (B) To canister (Negative pressure) | (D) Valve cannot be open. |                       |

# DIAGNOSTIC TROUBLE CODE (DTC) DETECTING CRITERIA

## GENERAL DESCRIPTION

### • Diagnostic method

CCV closed fixation diagnosis and CPC open fixation diagnosis are performed in mode Z as shown in the figure below.

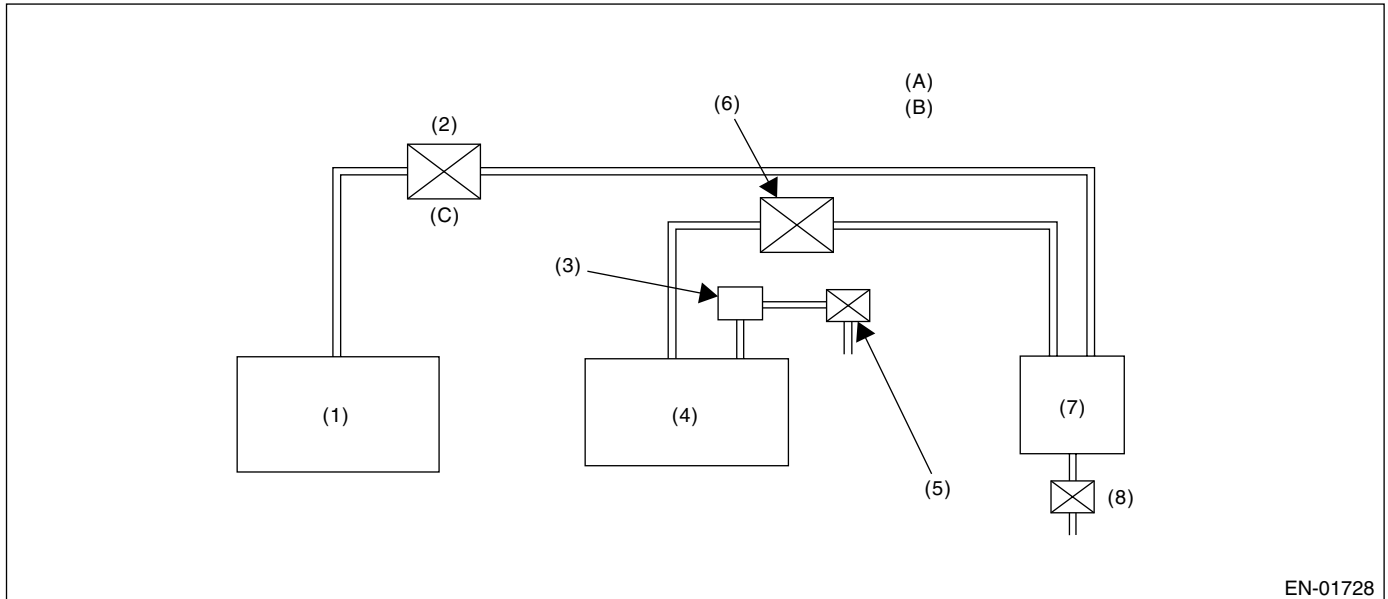

- (1) Engine
- (2) Purge control solenoid valve
- (3) Canister
- (4) Drain valve
- (5) Pressure control solenoid valve

- (6) Fuel tank
- (7) Fuel tank pressure sensor
- (8) Tank pressure switching solenoid valve

- (A) Normal condition: mechanical control
- (B) Under the diagnosis: electronic control

# DIAGNOSTIC TROUBLE CODE (DTC) DETECTING CRITERIA

GENERAL DESCRIPTION

## • Normal Operation

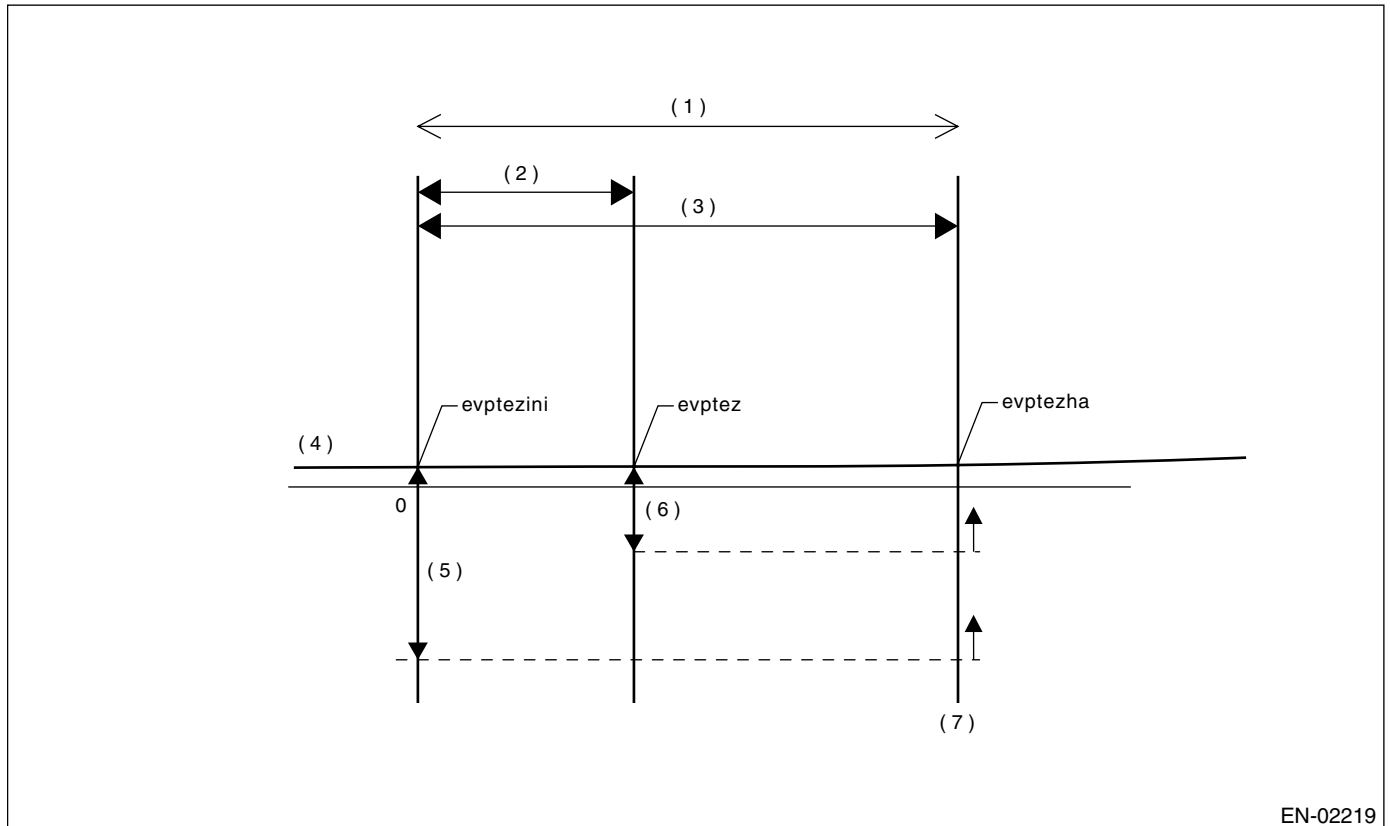

(1) Mode Z

(2) 1 second

(3) 3 seconds

(4) Fuel tank pressure

(5) 1.0 kPa (7.5 mmHg, 0.295 inHg)

(6) 0.4 kPa (3.0 mmHg, 0.12 inHg)

(7) Ok judgment

- $evptez - evpte zha \leq 0.4 \text{ kPa (3.0 mmHg, 0.12 inHg)}$
  - $evptezini - evpte zha \leq 1.0 \text{ kPa (7.5 mmHg, 0.295 inHg)}$
- Judge normal when these calculations are completed.

# DIAGNOSTIC TROUBLE CODE (DTC) DETECTING CRITERIA

## GENERAL DESCRIPTION

### • Drain valve close fixation

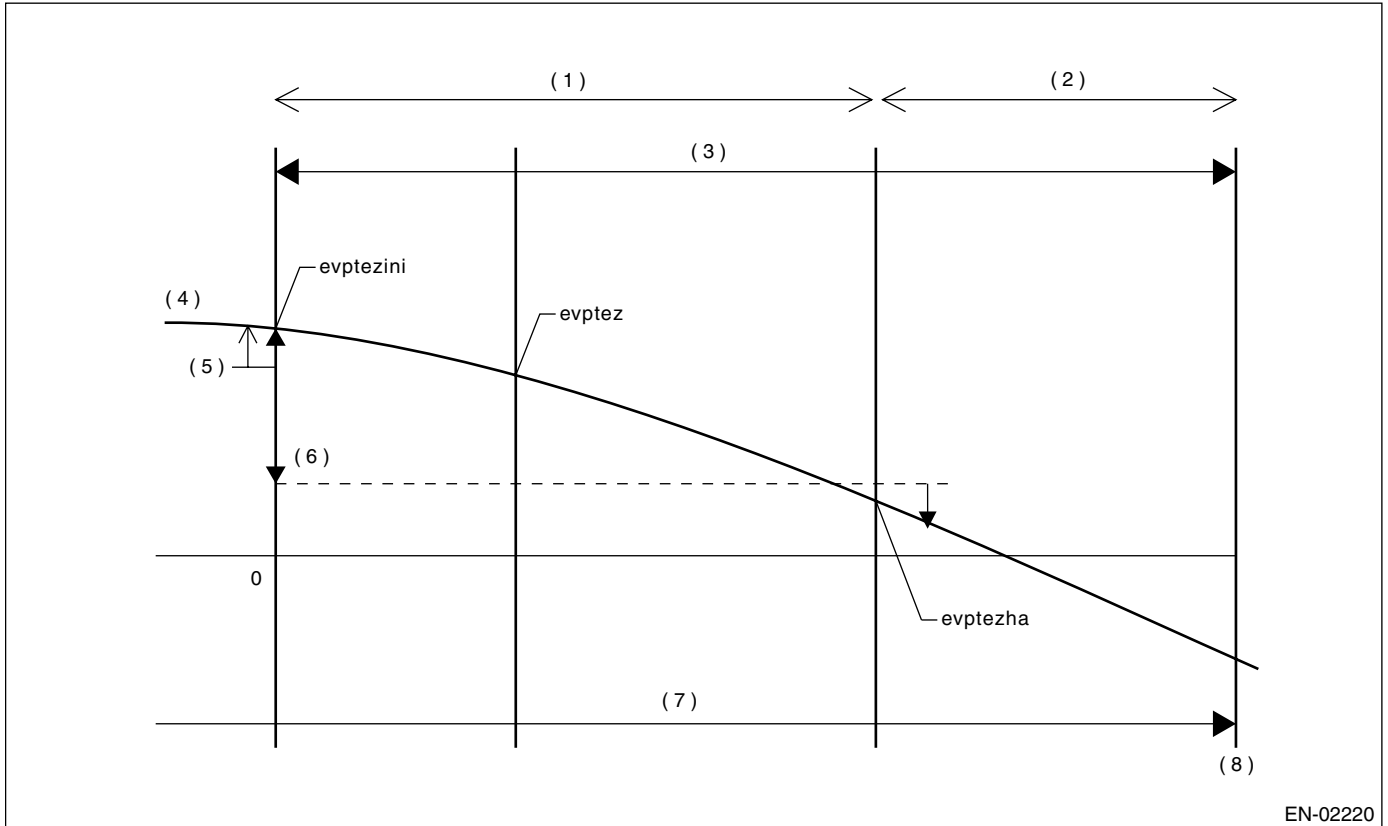

EN-02220

- |                     |                                    |  |
|---------------------|------------------------------------|--|
| (1) Mode Z          | (4) Fuel tank pressure             | (7) No fuel rolling for more than 35 seconds |
| (2) Extended Mode Z | (5) 1.0 kPa (7.5 mmHg, 0.177 inHg) | (8) NG judgment                              |
| (3) 10 seconds      | (6) 0.6 kPa (4.5 mmHg, 0.295 inHg) |  |

•  $evptezini - evptezha > 0.6 \text{ kPa (4.5 mmHg, 0.177 inHg)}$

•  $evptezini > 1.0 \text{ kPa (7.5 mmHg, 0.295 inHg)}$

Judge normal when these calculations are completed.

### • Diagnosing Function of CCV [P1443]

CCV functional diagnosis is performed by monitoring the tank pressure variation in Mode Z.

#### Normality Judgment

Judge OK and change to Mode A when the criteria below are completed in 3 seconds after Mode Z started.

#### • Judgment Value

Malfunction Criteria	Threshold Value	DTC
(Tank pressure in 1 second after starting Mode Z) – (Tank pressure when Mode Z finished)	$\leq 0.4 \text{ kPa (3.0 mmHg, 0.12 inHg)}$	P1443
(Tank pressure when Mode Z started) – (Tank pressure when Mode Z finished)	$\leq 1.0 \text{ kPa (7.5 mmHg, 0.295 inHg)}$	

# DIAGNOSTIC TROUBLE CODE (DTC) DETECTING CRITERIA

GENERAL DESCRIPTION

## Abnormality Judgment

If OK judgment cannot be made, extend Mode Z 16 seconds more, and judge NG when all the criteria below are completed in 16 seconds.

### • Judgment Value

Malfunction Criteria	Threshold Value	DTC
Tank pressure when Mode Z started	> 1.0 kPa (7.5 mmHg, 0.295 inHg)	P1443
(Tank pressure when Mode Z started) – (Tank pressure when Mode Z finished)	> 0.6 kPa (4.5 mmHg, 0.18 inHg)	

**Time Needed for Diagnosis:** 16 seconds

**Malfunction Indicator Light Illumination:** Illuminates when malfunction occurs in 2 continuous driving cycles.

Finish the evaporative emission control system diagnosis when making NG judgment for drain valve close fixation.

Cancel the evaporative emission control system diagnosis when the OK/NG judgment for drain valve close fixation and purge control solenoid valve open fixation cannot be made in Mode Z.

### • Leak Diagnosis

DTC P0442

DTC P0456

DTC P0457

### • Diagnostic method

- The diagnostic method consists of creating a sealed vacuum in the fuel tank and then determining the presence of leakage from the speed at which the tank internal pressure returns to atmospheric pressure.

- The diagnosis is divided into the following five phases.

#### Mode A:

Calculate the tank pressure variation amount (P1) in Mode A. After calculating P1, change to Mode B.

#### Mode B:

Introduce the negative pressure in the intake manifold to the tank.

Approx. 0 → -1.4 kPa (0 → -10.5 mmHg, 0 → -0.41 inHg) (0.04-in diagnosis)

Approx. 0 → -3.05 kPa (0 → -22.9 mmHg, 0 → -0.9 inHg) (0.02-in diagnosis)

When the pressure above (desired negative pressure) is reached, Mode C is entered.

In this case, if the tank pressure does not become the desired negative pressure, judge that there is a large leakage in the system.

Judge NG when the malfunction criteria below is completed.

Finish the Evap. diagnosis when judging large leak (35 seconds) in 0.04-inch diagnosis. Cancel the diagnosis (62 seconds) in 0.02-inch diagnosis.

## Abnormality Judgment

Judge NG (large leak) when the criteria below are completed in the specified time.

Specified Time

High vehicle speed mode (Vehicle speed ≥ 72 km/h (45 MPH)); 35 seconds

Low vehicle speed mode (Vehicle speed < 72 km/h (45 MPH)); 18 seconds

### • Judgment Value

Malfunction Criteria	Threshold Value	DTC
(0.04-inch diagnosis) (Tank pressure when Mode Z started) – (Min. value of tank pressure during Mode B)	< 0.3 kPa (2.25 mmHg, 0.089 inHg)	P0457

Cancel the diagnosis when the NG judgment does not completed in the specified time.

#### Mode C:

Stop the introduction of negative pressure. (Wait until the tank pressure returns to the start level of P2 calculation.)

Change to Mode D when the tank pressure returns to the start level of P2 calculation.

Judge immediate OK and change to Mode E when it does not return in spite of spending the specified time.

# DIAGNOSTIC TROUBLE CODE (DTC) DETECTING CRITERIA

## GENERAL DESCRIPTION

	Tank pressure when P2 calculation started	Time for immediate OK judgment
0.04-inch diagnosis	-1.3 kPa (-9.75 mmHg, -0.38 inHg)	16 seconds
0.02-inch diagnosis	-3 kPa (-22.5 mmHg, -0.89 inHg)	20 seconds

### Mode D:

Monitor the pressure variation in the tank in Mode D. In this case, the tank pressure increases, that is, the pressure becomes as high as the atmospheric air pressure, because evaporator is generated. However, if any leakage exists, the pressure increases additionally in proportion to this leakage. The pressure variation of this tank is P2.

After calculating P2, perform small leak diagnosis and change to Mode E if normal. Complete Evap. diagnosis if abnormal.

#### • After Diagnosis

Assigning P1 and P2, which are tank variations measured in Mode A and Mode B, to the formula below, judge the small leakage of the system. If the measured judgment value exceeds the threshold value, it is judged to be malfunction.

#### • 0.04-inch Diagnosis

#### Abnormality Judgment

Judge NG when the criteria below are completed and judge OK when not completed.

#### • Judgment Value

Malfunction Criteria	Threshold Value	DTC
$P2 - * \times P1$ P2 = Tank pressure varying at a specified time in mode D. P1 = Tank pressure varying at a specified time in mode A.	Map 1	P0442

\*  $P1 \geq 0: 1.5$

$P1 < 0: 1$

#### • Map 1

	Fuel temperature 25°C (77°F)	Fuel temperature 30°C (86°F)	Fuel temperature 35°C (95°F)	Fuel temperature 40°C (104°F)	Fuel temperature 45°C (113°F)
Fuel remaining 10 ℓ (2.6 US gal, 2.2 Imp gal)	0.34 kPa (2.53 mmHg, 0.10 inHg)	0.36 kPa (2.72 mmHg, 0.11 inHg)	0.44 kPa (3.28 mmHg, 0.13 inHg)	0.45 kPa (3.38 mmHg, 0.13 inHg)	0.46 kPa (3.47 mmHg, 0.14 inHg)
Fuel remaining 20 ℓ (5.3 US gal, 4.4 Imp gal)	0.44 kPa (3.28 mmHg, 0.13 inHg)	0.49 kPa (3.65 mmHg, 0.14 inHg)	0.53 kPa (3.94 mmHg, 0.14 inHg)	0.53 kPa (3.94 mmHg, 0.14 inHg)	0.53 kPa (3.94 mmHg, 0.14 inHg)
Fuel remaining 50 ℓ (13.2 US gal, 11.0 Imp gal)	0.53 kPa (3.94 mmHg, 0.14 inHg)	0.54 kPa (4.03 mmHg, 0.16 inHg)	0.56 kPa (4.22 mmHg, 0.17 inHg)	0.64 kPa (4.78 mmHg, 0.19 inHg)	0.66 kPa (4.97 mmHg, 0.2 inHg)

#### • 0.02-inch Diagnosis

#### Abnormality Judgment

Judge NG when the criteria below are completed.

# DIAGNOSTIC TROUBLE CODE (DTC) DETECTING CRITERIA

GENERAL DESCRIPTION

## • Judgment Value

Malfunction Criteria	Threshold Value	DTC
P2 – * × P1 P2 = Tank pressure varying at a specified time in mode D. P1 = Tank pressure varying at a specified time in mode A.	Map 2	P0456

\* P1 ≥ 0: 1.5

P1 < 0: 1

## • Map 2

	Fuel temperature 20°C (68°F)	Fuel temperature 25°C (77°F)	Fuel temperature 30°C (86°F)	Fuel temperature 35°C (95°F)	Fuel temperature 40°C (104°F)
Fuel remaining 10 ℓ (2.6 US gal, 2.2 Imp gal)	0.46 kPa (3.47 mmHg, 0.14 inHg)	0.46 kPa (3.47 mmHg, 0.14 inHg)	0.46 kPa (3.47 mmHg, 0.14 inHg)	0.46 kPa (3.47 mmHg, 0.14 inHg)	0.80 kPa (6.00 mmHg, 0.24 inHg)
Fuel remaining 30 ℓ (7.9 US gal, 6.6 Imp gal)	0.53 kPa (3.94 mmHg, 0.15 inHg)	0.53 kPa (3.94 mmHg, 0.15 inHg)	0.59 kPa (4.41 mmHg, 0.17 inHg)	0.66 kPa (4.97 mmHg, 0.2 inHg)	1.14 kPa (8.53 mmHg, 0.34 inHg)
Fuel remaining 50 ℓ (13.2 US gal, 11.0 Imp gal)	0.54 kPa (4.03 mmHg, 0.16 inHg)	0.59 kPa (4.41 mmHg, 0.17 inHg)	0.65 kPa (4.88 mmHg, 0.19 inHg)	0.65 kPa (4.88 mmHg, 0.19 inHg)	1.11 kPa (8.34 mmHg, 0.33 inHg)

## Normality Judgment

Judge OK when the criteria below are completed.

## • Judgment Value

Malfunction Criteria	Threshold Value	DTC
P2 – * × P1	Map 3	P0456

\* P1 ≥ 0: 1.5

P1 < 0: 1

# DIAGNOSTIC TROUBLE CODE (DTC) DETECTING CRITERIA

## GENERAL DESCRIPTION

### • Map 3

	Fuel temperature 20°C (68°F)	Fuel temperature 25°C (77°F)	Fuel temperature 30°C (86°F)	Fuel temperature 35°C (95°F)	Fuel temperature 40°C (104°F)
Fuel remaining 10 ℓ (2.6 US gal, 2.2 Imp gal)	0.32 kPa (2.43 mmHg, 0.096 inHg)	0.32 kPa (2.43 mmHg, 0.096 inHg)	0.39 kPa (2.91 mmHg, 0.115 inHg)	0.39 kPa (2.91 mmHg, 0.115 inHg)	0.39 kPa (2.91 mmHg, 0.115 inHg)
Fuel remaining 30 ℓ (7.9 US gal, 6.6 Imp gal)	0.31 kPa (2.34 mmHg, 0.092 inHg)	0.36 kPa (2.72 mmHg, 0.107 inHg)	0.39 kPa (2.91 mmHg, 0.115 inHg)	0.39 kPa (2.91 mmHg, 0.115 inHg)	0.39 kPa (2.91 mmHg, 0.115 inHg)
Fuel remaining 50 ℓ (13.2 US gal, 11.0 Imp gal)	0.31 kPa (2.34 mmHg, 0.092 inHg)	0.36 kPa (2.72 mmHg, 0.107 inHg)	0.39 kPa (2.91 mmHg, 0.115 inHg)	0.39 kPa (2.91 mmHg, 0.115 inHg)	0.39 kPa (2.91 mmHg, 0.115 inHg)

If not judged OK or NG, repeat the diagnosis.

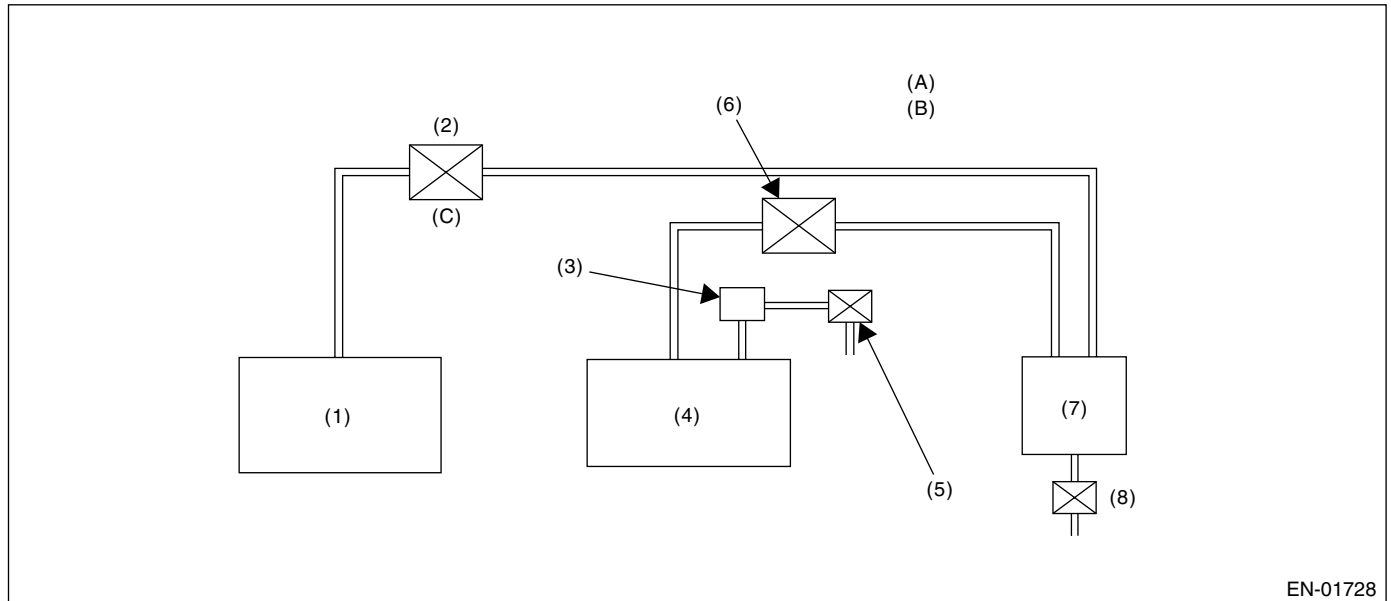

EN-01728

- |   |                                     |   |
|---|-------------------------------------|---|
| (1) Engine                                  | (6) Pressure control solenoid valve | (A) Normal condition: mechanical control    |
| (2) Purge control solenoid valve            | (7) Canister                        | (B) Under the diagnosis: electronic control |
| (3) Fuel tank pressure sensor               | (8) Drain valve                     | (C) Duty control                            |
| (4) Fuel tank                               |                                     |   |
| (5) Atmospheric pressure switching solenoid |                                     |   |



# DIAGNOSTIC TROUBLE CODE (DTC) DETECTING CRITERIA

GENERAL DESCRIPTION

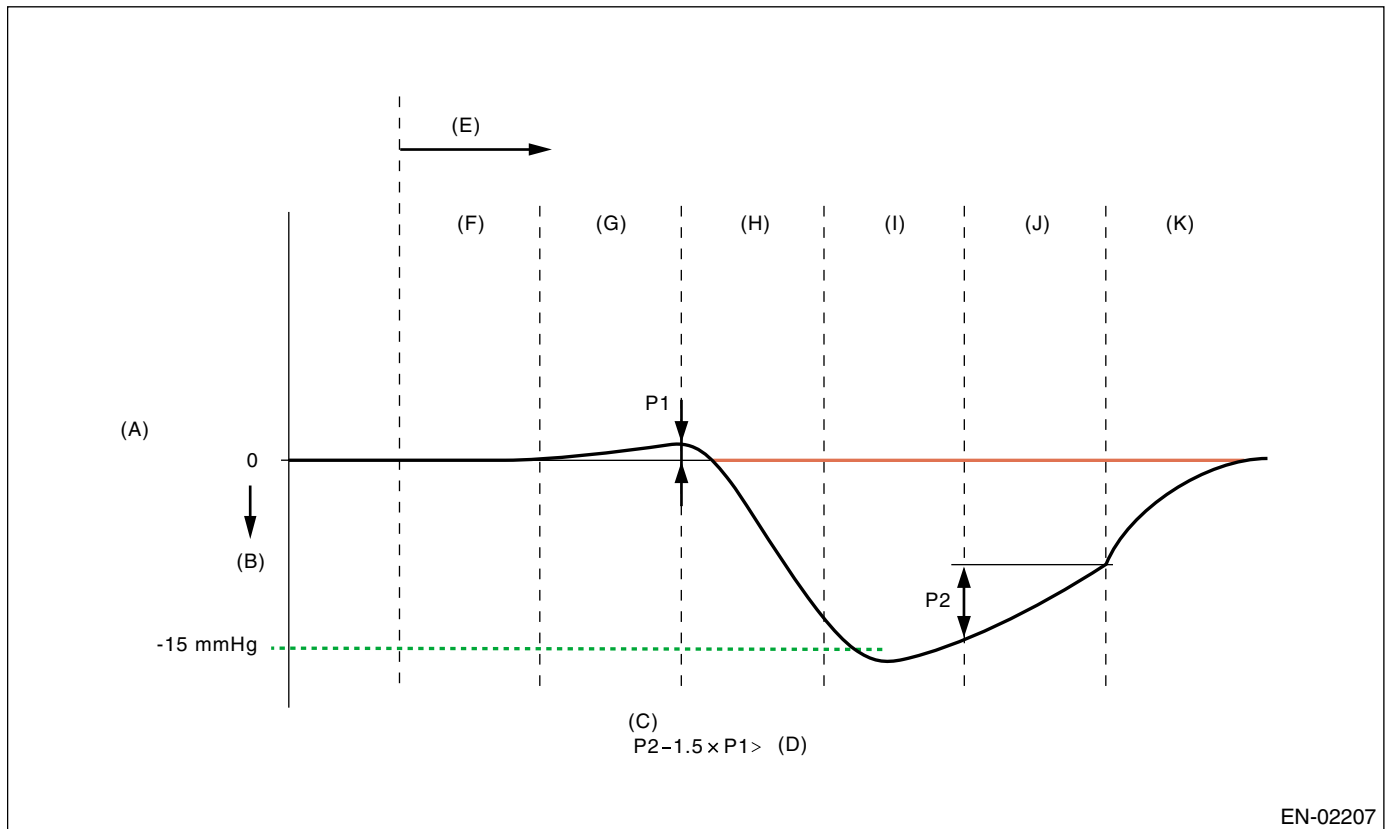

- |                                 |                     |            |
|---------------------------------|---------------------|------------|
| (A) Fuel tank internal pressure | (E) Diagnosis start | (I) Mode C |
| (B) Negative pressure           | (F) Mode Z          | (J) Mode D |
| (C) Small leakage               | (G) Mode A          | (K) Mode E |
| (D) Threshold value             | (H) Mode B          |            |

## • CCV Property Diagnosis [P1443]

### Mode E:

The tank pressure must become again as high as the atmospheric air pressure after the evaporation diagnosis. If the tank pressure does not become as high as the atmospheric air pressure, judge that CCV is blocked.

Malfunction Criteria	Threshold Value	DTC
Fuel tank pressure difference from the end of EVAP sys. diagnosis to 4 seconds later	< 0.4 kPa (3.0 mmHg, 0.118 inHg)	P1443

### • Time Needed for Diagnosis:

- |            |                 |
|------------|-----------------|
| 0.04-inch: | 30 — 70 seconds |
| 0.02-inch: | 45 — 90 seconds |

**Malfunction Indicator Light Illumination:** Illuminates when malfunction occurs in 2 continuous driving cycles.

## 6. DTC CLEAR CONDITION

- When the OK idling cycle was completed 40 times in a row
- When "Clear Memory" was performed

# DIAGNOSTIC TROUBLE CODE (DTC) DETECTING CRITERIA

## GENERAL DESCRIPTION

---

### 7. MALFUNCTION INDICATOR LIGHT CLEAR CONDITION

- When the OK driving cycle was completed 3 times in a row
- When “Clear Memory” was performed

### 8. FAIL SAFE

Atmospheric purge solenoid function malfunction; Open the pressure control solenoid valve.

### 9. ECM OPERATION AT DTC SETTING

- Memorize the freeze frame data. (For test mode \$02)
- Memorize the diagnostic value and trouble standard value. (For test mode \$06)

# DIAGNOSTIC TROUBLE CODE (DTC) DETECTING CRITERIA

GENERAL DESCRIPTION

---

MEMO:

# DIAGNOSTIC TROUBLE CODE (DTC) DETECTING CRITERIA

## GENERAL DESCRIPTION

### AW:DTC P0447 — EVAPORATIVE EMISSION CONTROL SYSTEM VENT CONTROL CIRCUIT OPEN —

#### 1. OUTLINE OF DIAGNOSIS

Detect the open or short circuit of drain valve.

Judge NG when the ECM output level is not equal to the actual terminal level.

#### 2. COMPONENT DESCRIPTION

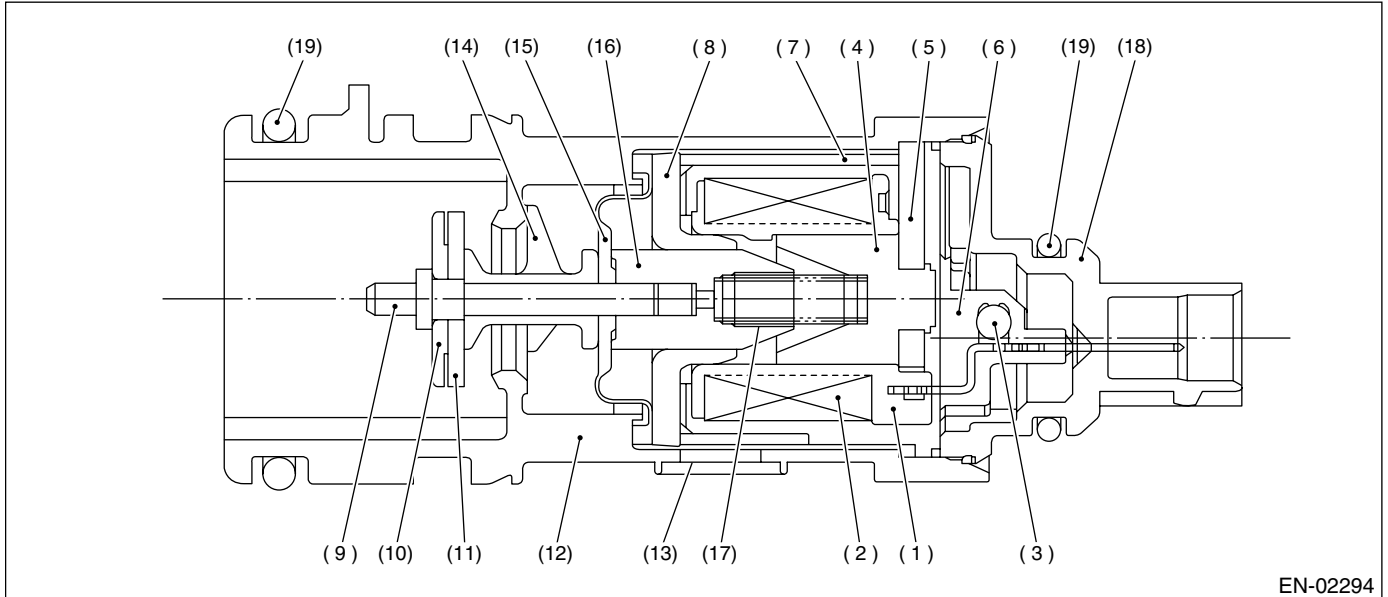

EN-02294

- |                 |                    |                  |
|-----------------|--------------------|------------------|
| (1) Bobbin      | (8) Magnetic plate | (15) Diaphragm   |
| (2) Coil        | (9) Shaft          | (16) Moving core |
| (3) Diode       | (10) Plate         | (17) Spring      |
| (4) Stator core | (11) Valve         | (18) Cover       |
| (5) End plate   | (12) Housing       | (19) O-ring      |
| (6) Body        | (13) Filter        |                  |
| (7) Yoke        | (14) Retainer      |                  |

#### 3. ENABLE CONDITION

Secondary Parameter	Enable Condition
Engine speed	$\geq 500$ rpm
Battery voltage	$\geq 8$ V
After starting the engine	1 second or more
Ignition switch	ON

#### 4. GENERAL DRIVING CYCLE

Perform the diagnosis continuously after starting the engine.

#### 5. DIAGNOSTIC METHOD

##### • Abnormality Judgment

Judge NG when the continuous time until completing the malfunction criteria below become more than time (2.5 seconds) needed for diagnosis.

# DIAGNOSTIC TROUBLE CODE (DTC) DETECTING CRITERIA

GENERAL DESCRIPTION

## • Judgment Value

Malfunction Criteria	Threshold Value
Terminal voltage when ECM outputs OFF signal.	Low

**Time Needed for Diagnosis:** 2.5 seconds

**Malfunction Indicator Light Illumination:** Illuminates when malfunction occurs in 2 continuous driving cycles.

## • Normality Judgment

Judge OK and clear the NG when the malfunction criteria below are completed.

## • Judgment Value

Malfunction Criteria	Threshold Value
Terminal voltage when ECM outputs OFF signal.	High

## 6. DTC CLEAR CONDITION

- When the OK idling cycle was completed 40 times in a row
- When "Clear Memory" was performed

## 7. MALFUNCTION INDICATOR LIGHT CLEAR CONDITION

- When the OK driving cycle was completed 3 times in a row
- When "Clear Memory" was performed

## 8. FAIL SAFE

Open PCV solenoid.

## 9. ECM OPERATION AT DTC SETTING

Memorize the freeze frame data. (For test mode \$02)

# DIAGNOSTIC TROUBLE CODE (DTC) DETECTING CRITERIA

## GENERAL DESCRIPTION

### AX:DTC P0448 — EVAPORATIVE EMISSION CONTROL SYSTEM VENT CONTROL CIRCUIT SHORTED —

#### 1. OUTLINE OF DIAGNOSIS

Detect the short circuit of drain valve.

Judge NG when the ECU output level is not equal to the actual terminal level.

#### 2. COMPONENT DESCRIPTION

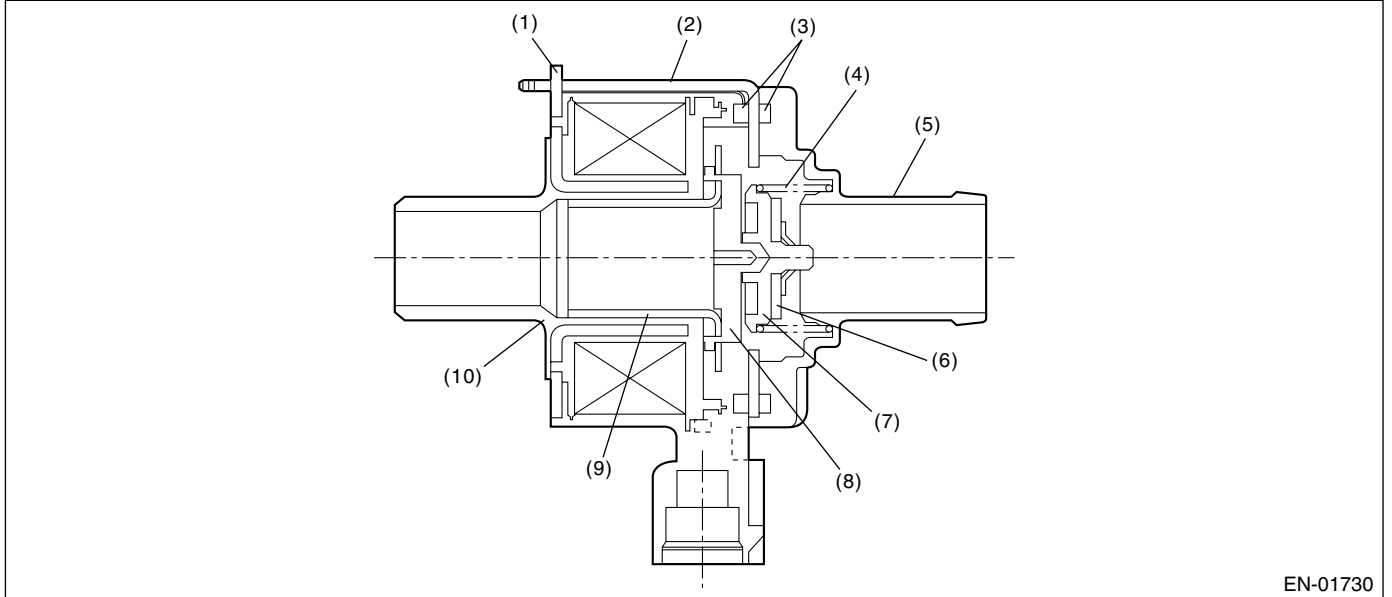

EN-01730

- |                    |                |                  |
|--------------------|----------------|------------------|
| (1) Magnetic plate | (5) Valve seat | (9) Movable core |
| (2) Yoke           | (6) Valve      | (10) Bobbin      |
| (3) Packing        | (7) Plate      |                  |
| (4) Spring         | (8) Retainer   |                  |

#### 3. ENABLE CONDITION

Secondary Parameter	Enable Condition
Engine speed	$\geq 500$ rpm
Battery voltage	$\geq 8$ V
After starting the engine	1 second or more
Ignition switch	ON

#### 4. GENERAL DRIVING CYCLE

Perform the diagnosis continuously after starting the engine.

#### 5. DIAGNOSTIC METHOD

##### • Abnormality Judgment

Judge NG when the continuous time until completing the malfunction criteria below become more than time (2.5 seconds) needed for diagnosis.

##### • Judgment Value

Malfunction Criteria	Threshold Value
Terminal voltage when ECM outputs ON signal.	High

**Time Needed for Diagnosis:** 2.5 seconds

# DIAGNOSTIC TROUBLE CODE (DTC) DETECTING CRITERIA

GENERAL DESCRIPTION

**Malfunction Indicator Light Illumination:** Illuminates when malfunction occurs in 2 continuous driving cycles.

- **Normality Judgment**

Judge OK and clear the NG when the malfunction criteria below are completed.

- **Judgment Value**

Malfunction Criteria	Threshold Value
Terminal voltage when ECM outputs ON signal.	Low

## 6. DTC CLEAR CONDITION

- When the OK idling cycle was completed 40 times in a row
- When "Clear Memory" was performed

## 7. MALFUNCTION INDICATOR LIGHT CLEAR CONDITION

- When the OK driving cycle was completed 3 times in a row
- When "Clear Memory" was performed

## 8. FAIL SAFE

Open PCV solenoid.

## 9. ECM OPERATION AT DTC SETTING

Memorize the freeze frame data. (For test mode \$02)

# DIAGNOSTIC TROUBLE CODE (DTC) DETECTING CRITERIA

## GENERAL DESCRIPTION

### AY:DTC P0451 — EVAPORATIVE EMISSION CONTROL SYSTEM PRESSURE SENSOR RANGE/PERFORMANCE —

#### 1. OUTLINE OF DIAGNOSIS

Detect the malfunction of tank pressure sensor output property.

Judge NG when there is little variation in the fuel tank pressure even if the vehicle is in driving status where there must be variation in the fuel tank pressure considering the fuel temperature and fuel level.

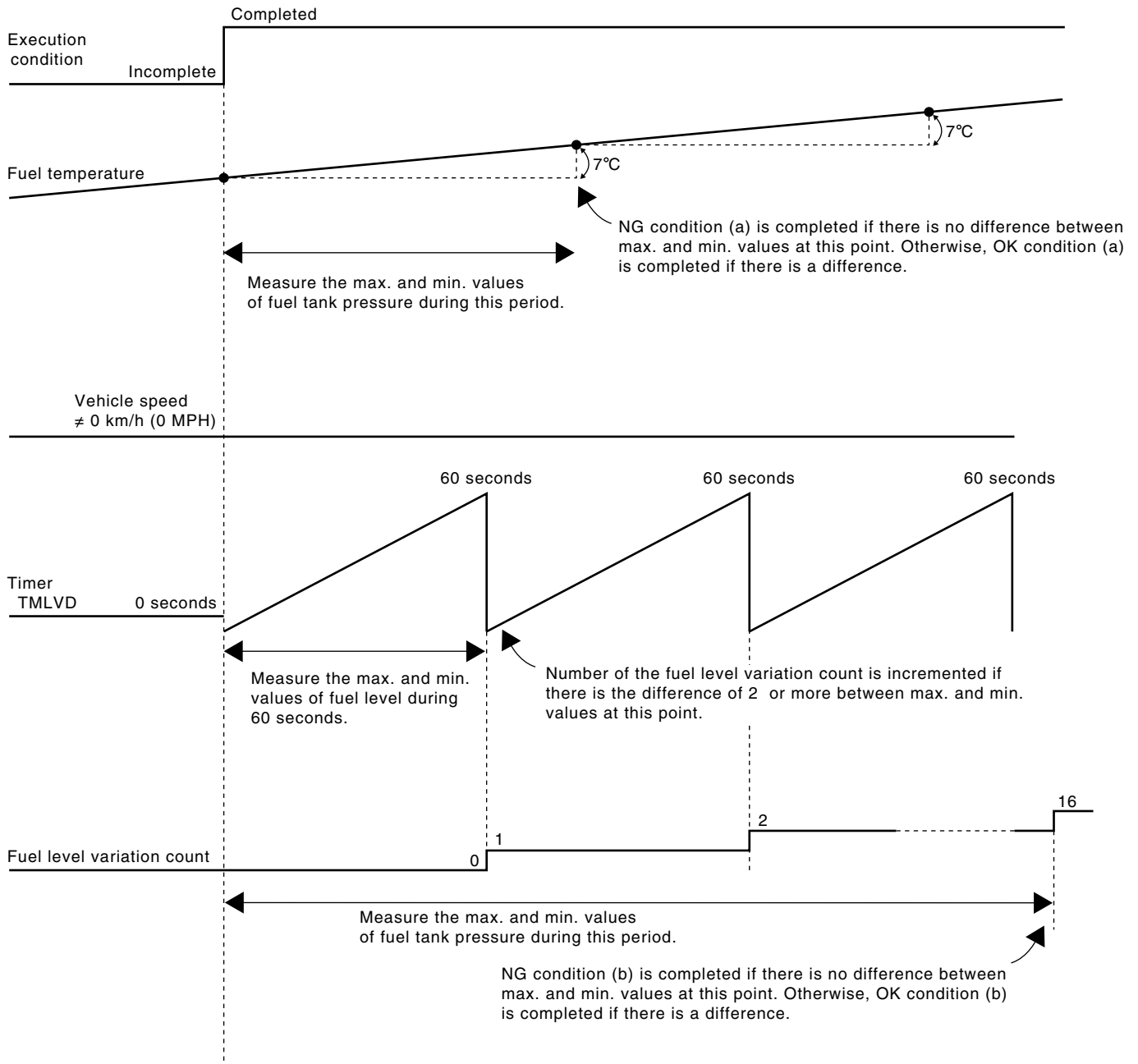

EN-01731



# DIAGNOSTIC TROUBLE CODE (DTC) DETECTING CRITERIA

GENERAL DESCRIPTION

- If NG condition (a) & (b) are experienced, NG results.  
(If there is OK, NG experience becomes unexperienced.)
- If OK conditions (a) & (b) are experienced, OK results.  
(If there is NG, OK experience becomes unexperienced.)

## 2. COMPONENT DESCRIPTION

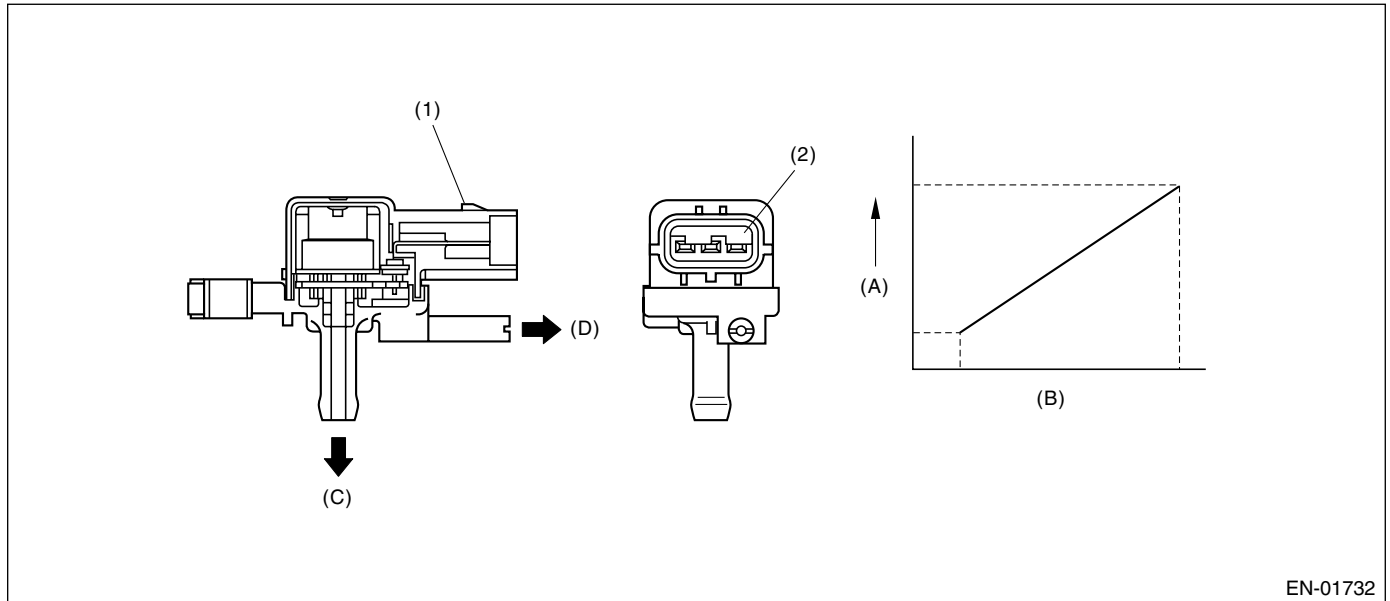

EN-01732

- (1) Connector  
(2) Terminal

- (A) Output voltage  
(B) Input voltage  
(C) To fuel tank

- (D) To tank pressure switching solenoid valve

## 3. ENABLE CONDITION

Secondary Parameters	Enable Conditions
Timer after starting the engine	$\geq 30$ seconds
Fuel level	$\geq 9 \ell$ (2.4 US gal, 2.0 Imp gal)

## 4. GENERAL DRIVING CYCLE

Perform the diagnosis continuously in 30 seconds after starting the engine.

# DIAGNOSTIC TROUBLE CODE (DTC) DETECTING CRITERIA

## GENERAL DESCRIPTION

### 5. DIAGNOSTIC METHOD

- (1) There is no tank pressure variation when there is fuel temperature variation of 7°C (45°F).
- (2) There is no tank pressure variation even when there is fuel level variation of 2 ℓ (0.5 US gal, 0.4 Imp gal) or more every 60 seconds.

Judge NG when both of the conditions above are experienced.

#### • Abnormality Judgment

Judge NG when both of the conditions below are experienced.

#### • Judgment Value

Malfunction Criteria	Threshold Value
Change of fuel temperature	≥ 7°C (45°F)
Max. – min. tank pressure	≤ 100 Pa (0.75 mmHg, 0.03 inHg)
Total time lapse where there is fuel level variation of 2 ℓ (0.5 US gal, 0.4 Imp gal) or more per minute.	≥ 16 minutes

**Time Needed for Diagnosis:** 10 minutes

**Malfunction Indicator Light Illumination:** Illuminates when malfunction occurs in 2 continuous driving cycles.

#### • Normality Judgment

Judge OK when both of the conditions below are experienced, and clear NG.

#### • Judgment Value

Malfunction Criteria	Threshold Value
Max. – min. tank pressure (During fuel temperature variation of 7°C (45°F))	> 100 Pa (0.75 mmHg, 0.03 inHg)
Change of fuel temperature	≥ 7°C (45°F)

Malfunction Criteria	Threshold Value
Max. – min. tank pressure (During time lapse below)	> 100 Pa (0.75 mmHg, 0.03 inHg)
Total time lapse where there is fuel level variation of 2 ℓ (0.5 US gal, 0.4 Imp gal) or more per minute.	≥ 10 minutes

### 6. DTC CLEAR CONDITION

- When the OK idling cycle was completed 40 times in a row
- When “Clear Memory” was performed

### 7. MALFUNCTION INDICATOR LIGHT CLEAR CONDITION

- When the OK driving cycle was completed 3 times in a row
- When “Clear Memory” was performed

### 8. FAIL SAFE

Fix the fuel tank pressure at 0 kPa (0 mmHg, 0 inHg).

### 9. ECM OPERATION AT DTC SETTING

Memorize the freeze frame data. (For test mode \$02)

**DIAGNOSTIC TROUBLE CODE (DTC) DETECTING CRITERIA**

GENERAL DESCRIPTION

---

**MEMO:**

# DIAGNOSTIC TROUBLE CODE (DTC) DETECTING CRITERIA

## GENERAL DESCRIPTION

### AZ:DTC P0452 — EVAPORATIVE EMISSION CONTROL SYSTEM PRESSURE SENSOR LOW INPUT —

#### 1. OUTLINE OF DIAGNOSIS

Detect the open or short circuit of tank pressure sensor.  
Judge NG when out of the standard value.

#### 2. COMPONENT DESCRIPTION

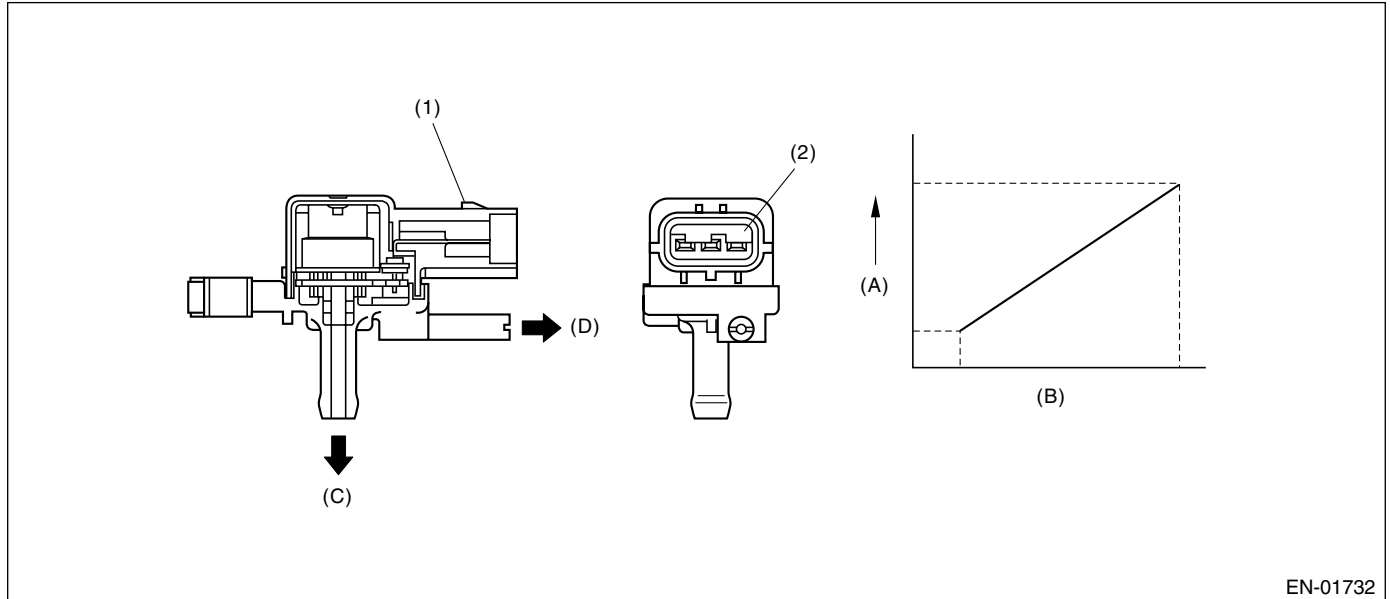

EN-01732

(1) Connector

(2) Terminal

(A) Output voltage

(B) Input voltage

(C) To fuel tank

(D) To tank pressure switching solenoid valve

#### 3. ENABLE CONDITION

Secondary Parameters	Enable Conditions
Engine speed	$\geq 500$ rpm
Battery voltage	$\geq 10$ V
After engine starting	2 seconds or more
Pressure control solenoid valve	Opened
Vent control solenoid valve	Closed
Canister purge control solenoid valve duty ratio	$\leq 0\%$

#### 4. GENERAL DRIVING CYCLE

Perform the diagnosis continuously in 2 seconds after starting the engine.

# DIAGNOSTIC TROUBLE CODE (DTC) DETECTING CRITERIA

GENERAL DESCRIPTION

## 5. DIAGNOSTIC METHOD

### • Abnormality Judgment

Judge NG when the continuous time until completing all of the malfunction criteria below becomes more than time needed for diagnosis.

### • Judgment Value

Malfunction Criteria	Threshold Value
Output voltage	< 0.2 V

**Time Needed for Diagnosis:** 20 seconds

**Malfunction Indicator Light Illumination:** Illuminates as soon as malfunction occurs.

### • Normality Judgment

Judge OK and clear the NG when the malfunction criteria below are completed

### • Judgment Value

Malfunction Criteria	Threshold Value
Output voltage	$\geq 0.2$ V

## 6. DTC CLEAR CONDITION

- When the OK idling cycle was completed 40 times in a row
- When "Clear Memory" was performed

## 7. MALFUNCTION INDICATOR LIGHT CLEAR CONDITION

- When the OK driving cycle was completed 3 times in a row
- When "Clear Memory" was performed

## 8. FAIL SAFE

Fix the fuel tank pressure at 0 kPa (0 mmHg, 0 inHg).

## 9. ECM OPERATION AT DTC SETTING

Memorize the freeze frame data. (For test mode \$02)

# DIAGNOSTIC TROUBLE CODE (DTC) DETECTING CRITERIA

## GENERAL DESCRIPTION

### BA:DTC P0453 — EVAPORATIVE EMISSION CONTROL SYSTEM PRESSURE SENSOR HIGH INPUT —

#### 1. OUTLINE OF DIAGNOSIS

Detect the open or short circuit of tank pressure sensor.  
Judge NG when out of the standard value.

#### 2. COMPONENT DESCRIPTION

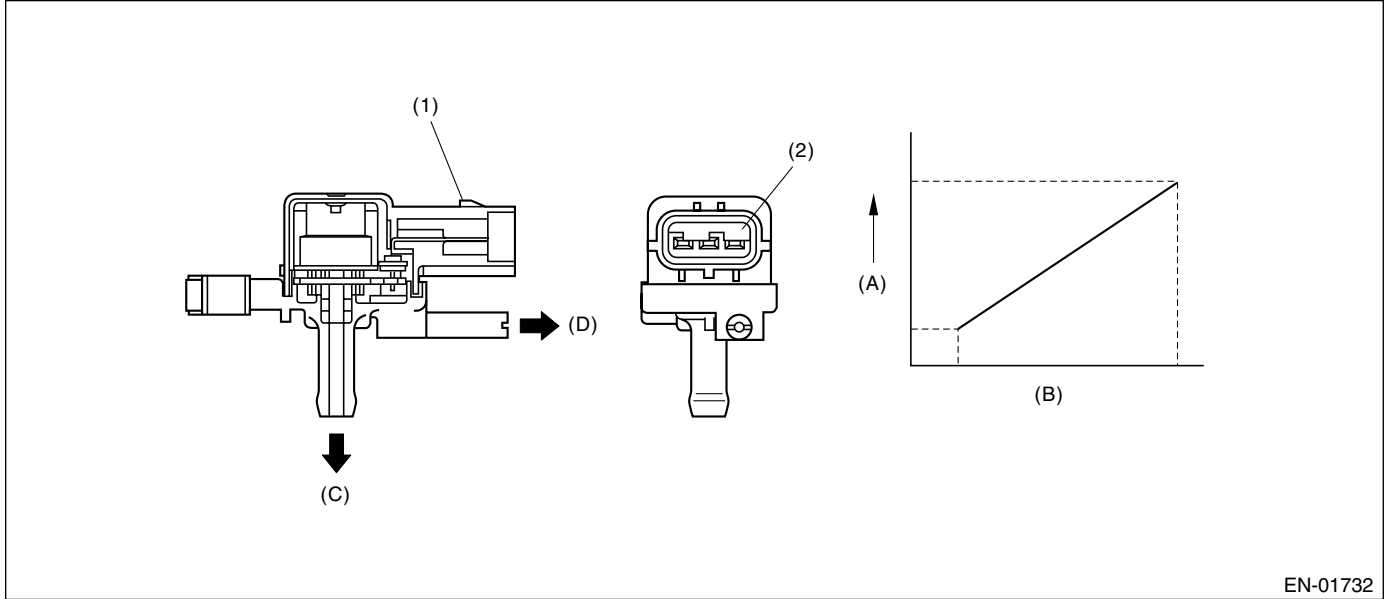

EN-01732

- (1) Connector
- (2) Terminal

- (A) Output voltage
- (B) Input voltage
- (C) To fuel tank

- (D) To tank pressure switching solenoid valve

#### 3. ENABLE CONDITION

Secondary Parameters	Enable Conditions
Engine speed	$\geq 500$ rpm
Battery voltage	$\geq 10$ V
After engine starting	2 seconds or more

#### 4. GENERAL DRIVING CYCLE

Perform the diagnosis continuously in 2 seconds after starting the engine.

# DIAGNOSTIC TROUBLE CODE (DTC) DETECTING CRITERIA

GENERAL DESCRIPTION

## 5. DIAGNOSTIC METHOD

### • Abnormality Judgment

Judge NG when the cumulative time until completing all of the malfunction criteria below becomes more than the time (20 seconds) needed for diagnosis.

### • Judgment Value

Malfunction Criteria	Threshold Value
Output voltage	$\geq 4.8$ V
Fuel temperature	$< 35^{\circ}\text{C}$ ( $95^{\circ}\text{F}$ )
Barometric pressure	$\geq 76$ kPa (568 mmHg, 22.4 inHg)

**Time Needed for Diagnosis:** 20 seconds

**Malfunction Indicator Light Illumination:** Illuminates as soon as malfunction occurs.

### • Normality Judgment

Judge OK and clear the NG when the malfunction criteria below are completed.

### • Judgment Value

Malfunction Criteria	Threshold Value
Output voltage	$< 4.8$ V

## 6. DTC CLEAR CONDITION

- When the OK idling cycle was completed 40 times in a row
- When "Clear Memory" was performed

## 7. MALFUNCTION INDICATOR LIGHT CLEAR CONDITION

- When the OK driving cycle was completed 3 times in a row
- When "Clear Memory" was performed

## 8. FAIL SAFE

Fix the fuel tank pressure at 0 kPa (0 mmHg, 0 inHg).

## 9. ECM OPERATION AT DTC SETTING

Memorize the freeze frame data. (For test mode \$02)

# DIAGNOSTIC TROUBLE CODE (DTC) DETECTING CRITERIA

## GENERAL DESCRIPTION

---

### **BB:DTC P0456 — EVAPORATIVE EMISSION CONTROL SYSTEM LEAK DETECTED (VERY SMALL LEAK) —**

#### **1. OUTLINE OF DIAGNOSIS**

For detecting conditions, refer to DTC P0442 EVAPORATIVE EMISSION CONTROL SYSTEM LEAK DETECTED (SMALL LEAK). <Ref. to GD(H4SO)-116, DTC P0442 — EVAPORATIVE EMISSION CONTROL SYSTEM LEAK DETECTED (SMALL LEAK) —, Diagnostic Trouble Code (DTC) Detecting Criteria.>

### **BC:DTC P0457 — EVAPORATIVE EMISSION CONTROL SYSTEM LEAK DETECTED (FUEL CAP LOOSE/OFF) —**

#### **1. OUTLINE OF DIAGNOSIS**

For detecting conditions, refer to DTC P0442 EVAPORATIVE EMISSION CONTROL SYSTEM LEAK DETECTED (SMALL LEAK). <Ref. to GD(H4SO)-116, DTC P0442 — EVAPORATIVE EMISSION CONTROL SYSTEM LEAK DETECTED (SMALL LEAK) —, Diagnostic Trouble Code (DTC) Detecting Criteria.>



# DIAGNOSTIC TROUBLE CODE (DTC) DETECTING CRITERIA

GENERAL DESCRIPTION

---

MEMO:

# DIAGNOSTIC TROUBLE CODE (DTC) DETECTING CRITERIA

## GENERAL DESCRIPTION

### BD:DTC P0458 — EVAPORATIVE EMISSION CONTROL SYSTEM PURGE CONTROL VALVE CIRCUIT —

#### 1. OUTLINE OF DIAGNOSIS

Detect the open or short circuit of purge control solenoid valve.  
Judge NG when ECM output level is different from actual terminal level.

#### 2. COMPONENT DESCRIPTION

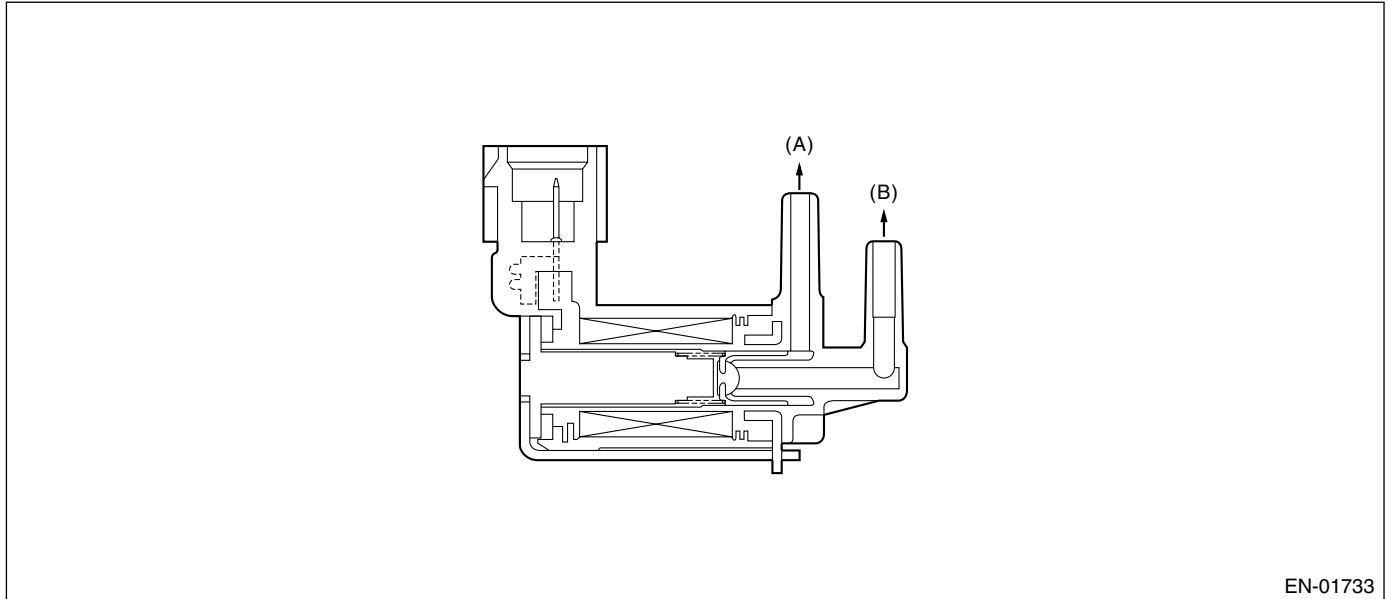

EN-01733

(A) To canister

(B) To intake manifold

#### 3. ENABLE CONDITION

Secondary Parameters	Enable Conditions
Engine speed	$\geq 500$ rpm
Battery voltage	$\geq 8$ V
After engine starting	1 second or more
Ignition switch	ON

#### 4. GENERAL DRIVING CYCLE

Perform the diagnosis continuously after starting the engine.

# DIAGNOSTIC TROUBLE CODE (DTC) DETECTING CRITERIA

GENERAL DESCRIPTION

## 5. DIAGNOSTIC METHOD

### • Abnormality Judgment

Judge NG when the cumulative time until completing all the malfunction criteria below becomes more than the time (2.5 seconds) needed for diagnosis.

### • Judgment Value

Malfunction Criteria	Threshold Value
Duty ratio of "ON"	< 75%
Terminal output voltage when ECM outputs OFF signal	Low

**Time Needed for Diagnosis:** 2.5 seconds

**Malfunction Indicator Light Illumination:** Illuminates when malfunction occurs in 2 continuous driving cycles.

### • Normality Judgment

Judge OK when the cumulative time until completing all the malfunction criteria below becomes more than 1 second.

### • Judgment Value

Malfunction Criteria	Threshold Value
Duty ratio of "ON"	< 75%
Terminal output voltage when ECM outputs OFF signal	High

## 6. DTC CLEAR CONDITION

- When the OK idling cycle is completed 40 times in a row
- When "Clear Memory" was performed

## 7. MALFUNCTION INDICATOR LIGHT CLEAR CONDITION

- When the OK driving cycle was completed 3 times in a row
- When "Clear Memory" was performed

## 8. FAIL SAFE

None

## 9. ECM OPERATION AT DTC SETTING

Memorize the freeze frame data. (For test mode \$02)

# DIAGNOSTIC TROUBLE CODE (DTC) DETECTING CRITERIA

## GENERAL DESCRIPTION

### BE:DTC P0459 — EVAPORATIVE EMISSION CONTROL SYSTEM PURGE CONTROL VALVE CIRCUIT HIGH —

#### 1. OUTLINE OF DIAGNOSIS

Detect the open or short circuit of purge control solenoid valve.  
Judge NG when ECM output level is different from actual terminal level.

#### 2. COMPONENT DESCRIPTION

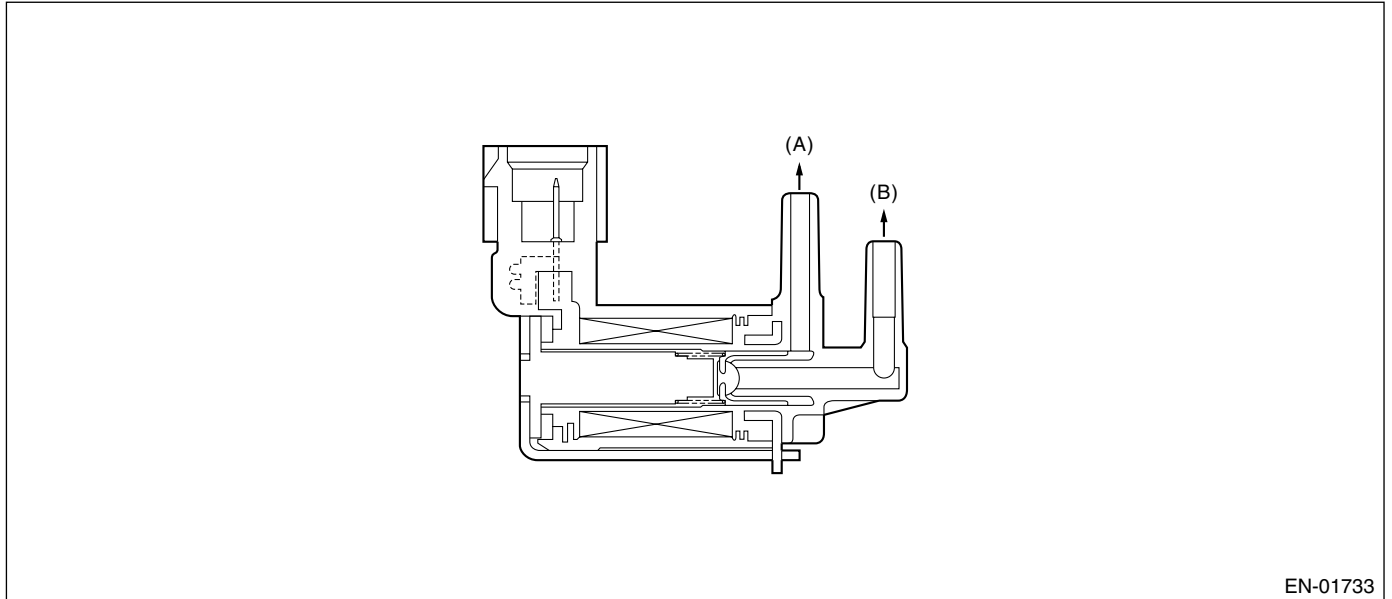

(A) To canister

(B) To intake manifold

#### 3. ENABLE CONDITION

Secondary Parameters	Enable Conditions
Engine speed	$\geq 500$ rpm
Battery voltage	$\geq 8$ V
After engine starting	1 second or more
Ignition switch	ON

#### 4. GENERAL DRIVING CYCLE

Perform the diagnosis continuously after starting the engine.

# DIAGNOSTIC TROUBLE CODE (DTC) DETECTING CRITERIA

GENERAL DESCRIPTION

## 5. DIAGNOSTIC METHOD

### • Abnormality Judgment

Judge NG when the cumulative time until completing the malfunction criteria below becomes more than the time (2.5 seconds) needed for diagnosis.

### • Judgment Value

Malfunction Criteria	Threshold Value
Duty ratio of "ON"	> 25%
Terminal output voltage when ECM outputs ON signal	High

**Time Needed for Diagnosis:** 2.5 seconds

**Malfunction Indicator Light Illumination:** Illuminates when malfunction occurs in 2 continuous driving cycles.

### • Normality Judgment

Judge OK when the cumulative time until completing the malfunction criteria below becomes more than 1 second.

### • Judgment Value

Malfunction Criteria	Threshold Value
Duty ratio of "ON"	> 25%
Terminal output voltage when ECM outputs OFF signal	Low

## 6. DTC CLEAR CONDITION

- When the OK idling cycle is completed 40 times in a row
- When "Clear Memory" was performed

## 7. MALFUNCTION INDICATOR LIGHT CLEAR CONDITION

- When the OK driving cycle was completed 3 times in a row
- When "Clear Memory" was performed

## 8. FAIL SAFE

None

## 9. ECM OPERATION AT DTC SETTING

Memorize the freeze frame data. (For test mode \$02)

# DIAGNOSTIC TROUBLE CODE (DTC) DETECTING CRITERIA

## GENERAL DESCRIPTION

### BF:DTC P0461 — FUEL LEVEL SENSOR CIRCUIT RANGE/PERFORMANCE —

#### 1. OUTLINE OF DIAGNOSIS

Detect the malfunction of fuel level sensor output property.

Judge NG by the difference between max. and min. value of fuel level during every 160 km (100 miles) driving distance converted from vehicle speed.

#### 2. COMPONENT DESCRIPTION

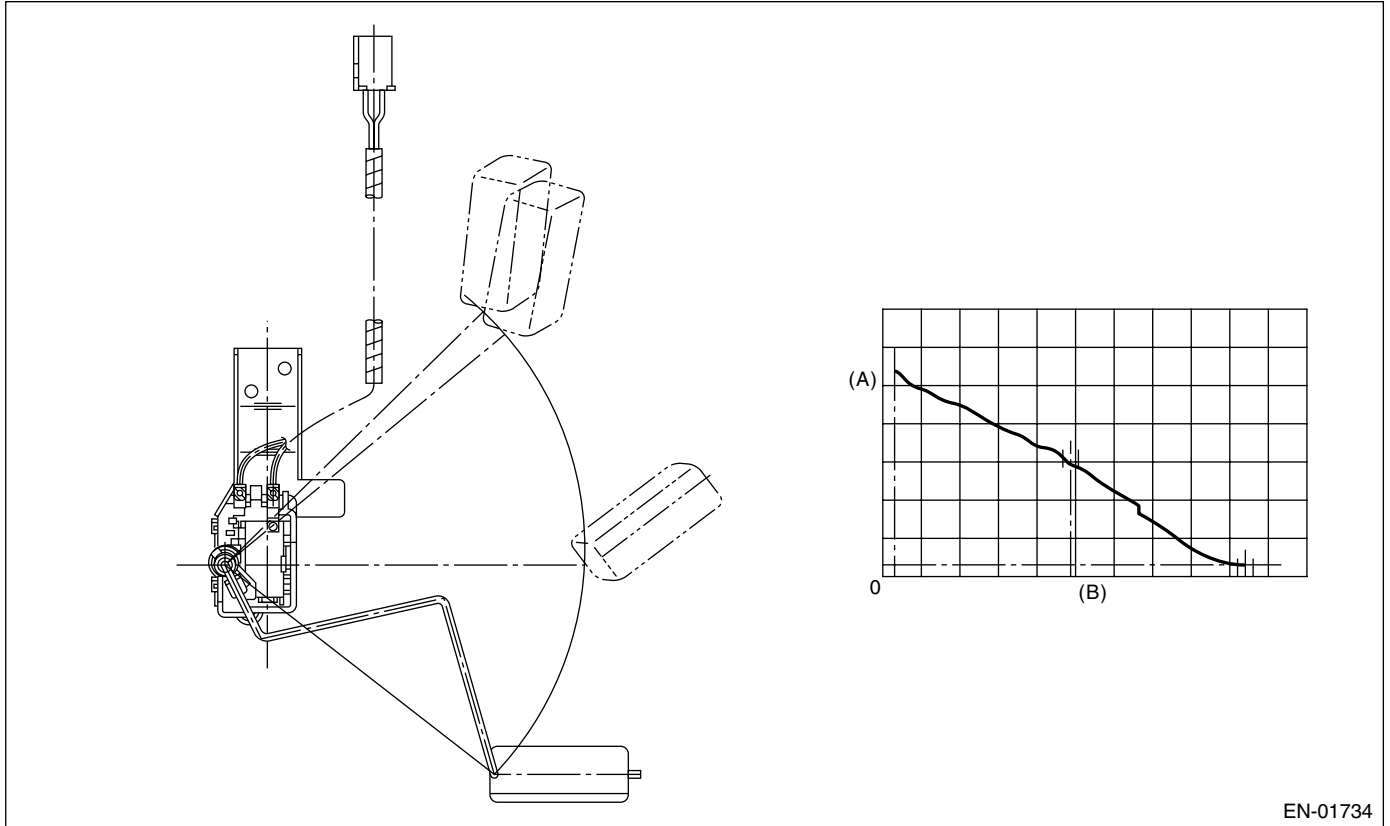

(A) Fuel level (L)

(B) Resistance ( $\Omega$ )

#### 3. ENABLE CONDITION

Secondary Parameters	Enable Conditions
None	

#### 4. GENERAL DRIVING CYCLE

Always perform the diagnosis continuously.

# DIAGNOSTIC TROUBLE CODE (DTC) DETECTING CRITERIA

GENERAL DESCRIPTION

## 5. DIAGNOSTIC METHOD

### • Abnormality Judgment

Judge NG when all the malfunction criteria below are completed.

### • Judgment Value

Malfunction Criteria	Threshold Value
Max. – min. fuel level	< 10 ℓ (2.6 US gal, 2.2 Imp gal)
Trip distance from last fill up	≥ 160 km (100 miles)

**Time Needed for Diagnosis:** Not determined.

**Malfunction Indicator Light Illumination:** Illuminates when malfunction occurs in 2 continuous driving cycles.

### • Normality Judgment

Judge OK and clear the NG when the malfunction criteria below are completed.

### • Judgment Value

Malfunction Criteria	Threshold Value
Max. – min. fuel level	≥ 10 ℓ (2.6 US gal, 2.2 Imp gal)

## 6. DTC CLEAR CONDITION

- When the OK idling cycle is completed 40 times in a row
- When “Clear Memory” was performed

## 7. MALFUNCTION INDICATOR LIGHT CLEAR CONDITION

- When the OK driving cycle is completed 3 times in a row
- When “Clear Memory” was performed

## 8. FAIL SAFE

None

## 9. ECM OPERATION AT DTC SETTING

Memorize the freeze frame data. (For test mode \$02)

# DIAGNOSTIC TROUBLE CODE (DTC) DETECTING CRITERIA

## GENERAL DESCRIPTION

### BG:DTC P0462 — FUEL LEVEL SENSOR CIRCUIT LOW INPUT —

#### 1. OUTLINE OF DIAGNOSIS

Detect the open or short circuit of fuel level sensor.  
Judge NG when out of the standard value.

#### 2. COMPONENT DESCRIPTION

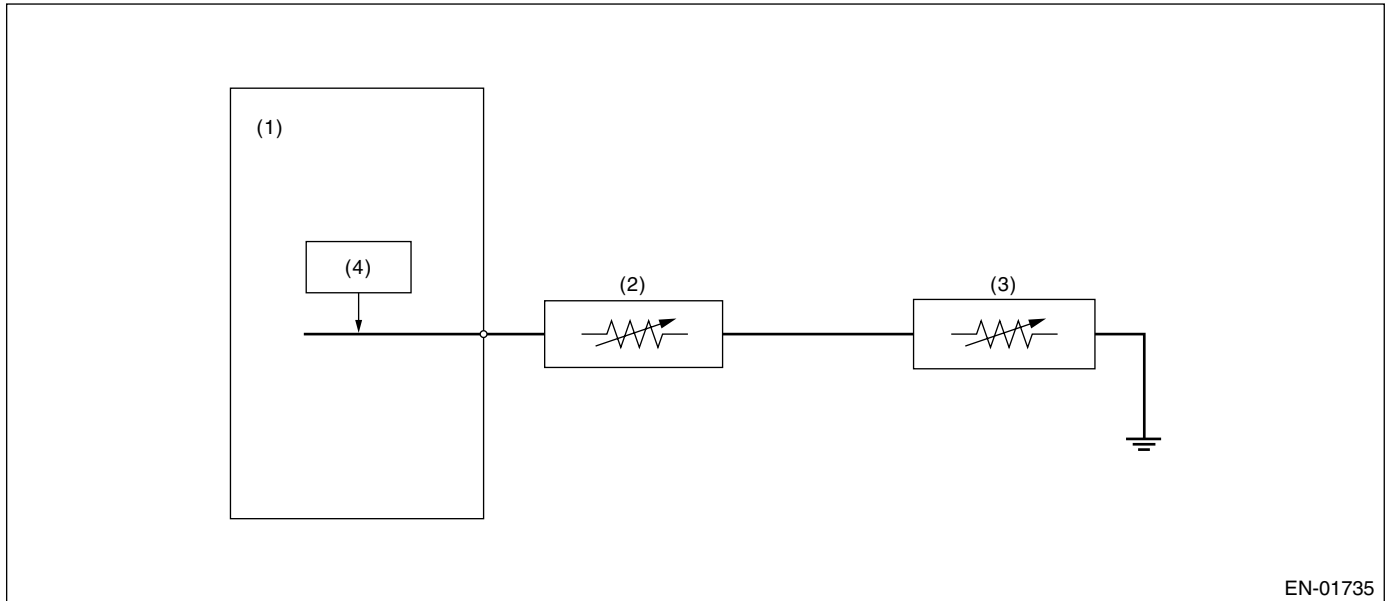

- (1) Engine control module (ECM)      (3) Fuel sub level sensor  
(2) Fuel level sensor                    (4) Detecting circuit

#### 3. ENABLE CONDITION

Secondary Parameters	Enable Conditions
Battery voltage	8 — 16 V
Ignition switch	ON

#### 4. GENERAL DRIVING CYCLE

Always perform the diagnosis continuously.

#### 5. DIAGNOSTIC METHOD

Judge NG when the continuous time of completing the malfunction criteria below becomes more than the time (2.5 seconds) needed for diagnosis, and then judge OK and clear the NG when the malfunction criteria below are not completed.

##### Judgment Value

Malfunction Criteria	Threshold Value
Output voltage	$\leq 0.02$ V

**Time Needed for Diagnosis:** 2.5 seconds

**Malfunction Indicator Light Illumination:** Illuminates when malfunction occurs in 2 continuous driving cycles.

#### 6. DTC CLEAR CONDITION

- When the OK driving cycle is completed 3 times in a row
- When "Clear Memory" was performed



# DIAGNOSTIC TROUBLE CODE (DTC) DETECTING CRITERIA

GENERAL DESCRIPTION

---

## 7. MALFUNCTION INDICATOR LIGHT CLEAR CONDITION

- When the OK driving cycle is completed 3 times in a row
- When "Clear Memory" was performed

## 8. FAIL SAFE

None

## 9. ECM OPERATION AT DTC SETTING

Memorize the freeze frame data. (For test mode \$02)

# DIAGNOSTIC TROUBLE CODE (DTC) DETECTING CRITERIA

## GENERAL DESCRIPTION

### BH:DTC P0463 — FUEL LEVEL SENSOR CIRCUIT HIGH INPUT —

#### 1. OUTLINE OF DIAGNOSIS

Detect the open or short circuit of fuel level sensor.  
Judge NG when out of the standard value.

#### 2. COMPONENT DESCRIPTION

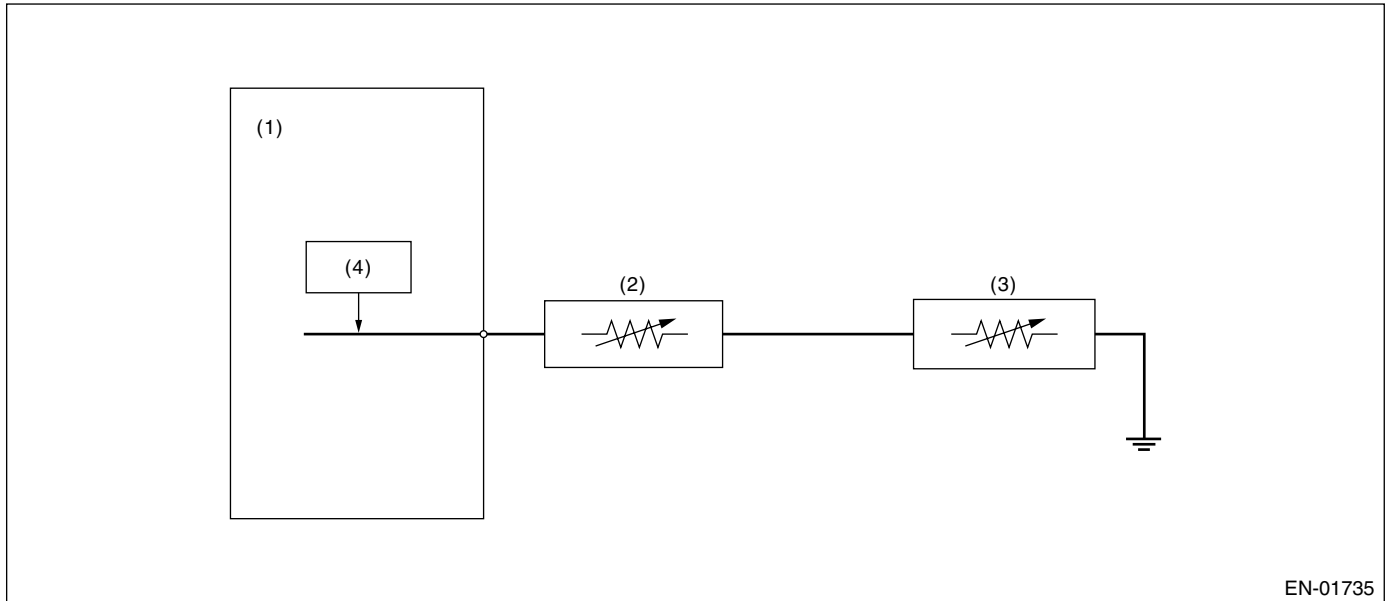

- (1) Engine control module (ECM)      (3) Fuel sub level sensor  
(2) Fuel level sensor                    (4) Detecting circuit

#### 3. ENABLE CONDITION

Secondary Parameter	Enable Conditions
Battery voltage	8 — 16 V
Ignition switch	ON

#### 4. GENERAL DRIVING CYCLE

Always perform the diagnosis continuously.

#### 5. DIAGNOSTIC METHOD

Judge NG when the cumulative time until completing the malfunction criteria below becomes more than the time (2.5 seconds) needed for diagnosis, and then judge OK and clear the NG when the malfunction criteria below are not completed.

##### Judgment Value

Malfunction Criteria	Threshold Value
Output voltage	$\geq 4.90$ V

**Time Needed for Diagnosis:** 2.5 seconds

**Malfunction Indicator Light Illumination:** Illuminates when malfunction occurs in 2 continuous driving cycles.

#### 6. DTC CLEAR CONDITION

- When the OK idling cycle is completed 40 times in a row
- When "Clear Memory" was performed

# DIAGNOSTIC TROUBLE CODE (DTC) DETECTING CRITERIA

GENERAL DESCRIPTION

---

## 7. MALFUNCTION INDICATOR LIGHT CLEAR CONDITION

- When the OK driving cycle is completed 3 times in a row
- When "Clear Memory" was performed

## 8. FAIL SAFE

None

## 9. ECM OPERATION AT DTC SETTING

Memorize the freeze frame data. (For test mode \$02)

# DIAGNOSTIC TROUBLE CODE (DTC) DETECTING CRITERIA

## GENERAL DESCRIPTION

---

### BI: DTC P0464 — FUEL LEVEL SENSOR CIRCUIT INTERMITTENT —

#### 1. OUTLINE OF DIAGNOSIS

Detect the malfunction of unstable output from fuel level sensor because of noise.

Judge NG by comparing the max value and cumulative value of the amount of output voltage variation from fuel level sensor with threshold value.

#### 2. ENABLE CONDITION

Secondary Parameters	Enable Conditions
Engine speed	$\geq 500$ rpm
Battery voltage	$> 10.9$ V
After engine starting	1 second or more
Idle switch	ON
Fuel level	9.6 — 48 ℓ (2.54 — 12.68 US gal, 2.11 — 10.56 Imp gal)
Vehicle speed = 0 km/h (0 MPH)	10 seconds or more
Ignition switch	ON
Difference between max. value and min. value of fuel tank pressure (12.8 seconds)	$< 0.05$ kPa (0.4 mmHg, 0.016 inHg)
Difference between max. value and min. value of battery voltage (12.8 seconds)	$< 0.4$ V

#### 3. GENERAL DRIVING CYCLE

Perform the diagnosis continuously at idling.

# DIAGNOSTIC TROUBLE CODE (DTC) DETECTING CRITERIA

GENERAL DESCRIPTION

## 4. DIAGNOSTIC METHOD

Calculate the max. value of the amount of output voltage variation from fuel level sensor and cumulative value during 12.8 seconds. Comparing the max value and cumulative value with the threshold value, and judge OK when the both do not go over the threshold value. Otherwise, when one of them goes over the threshold, count the counter up. Judge the ECM is troubled when the counter increased 4 times in a row.

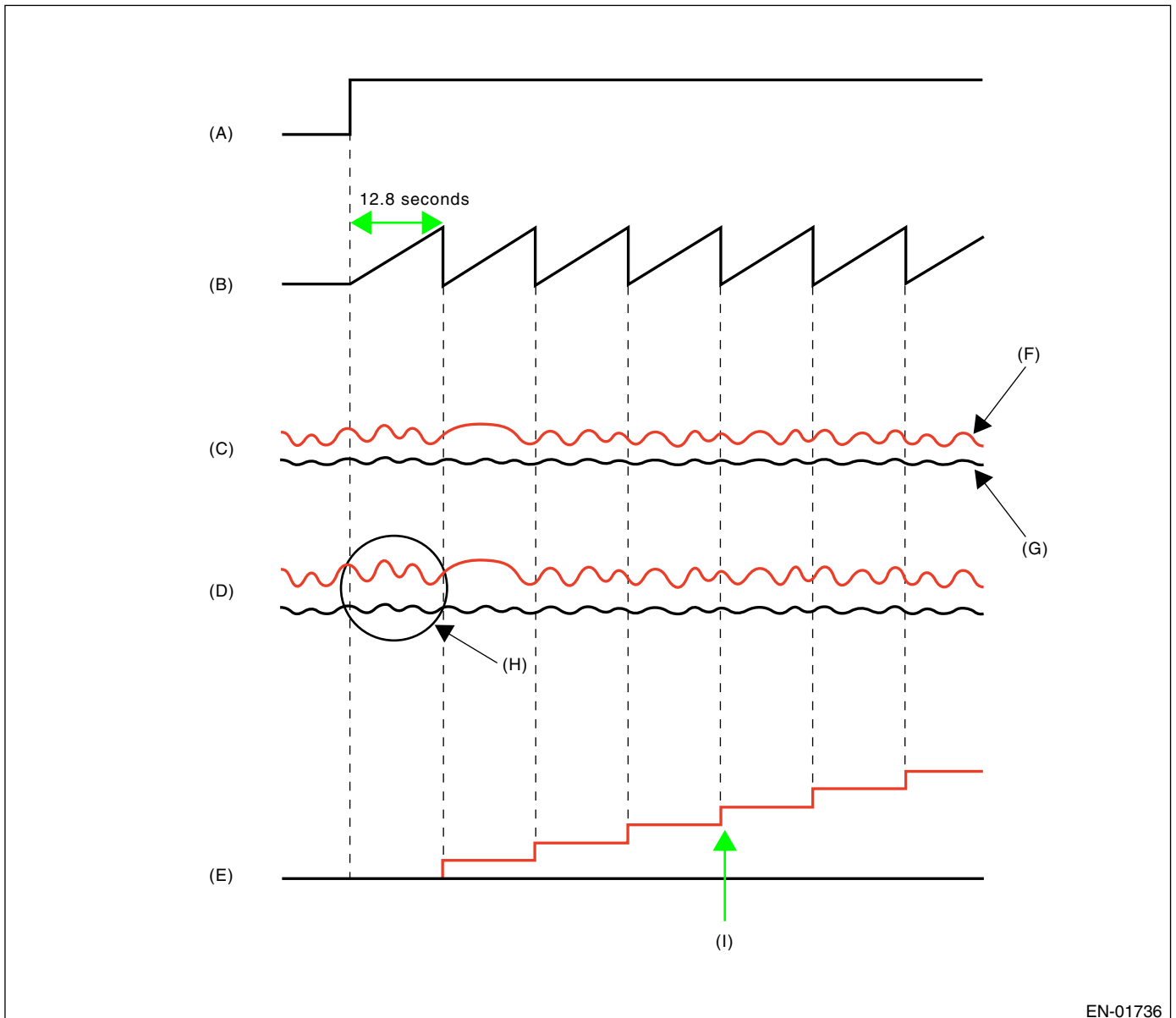

(A) Diagnosis condition

(B) Diagnosis timer

(C) Fuel level sensor A/D value

(D) Amount of Fuel level output voltage variation

(E) Diagnosis counter

(F) Malfunction

(G) Normal

(H) Regard the Max. value as delvflmx and the cumulative value as sumvfl.

(I) NG at 4 counts

# DIAGNOSTIC TROUBLE CODE (DTC) DETECTING CRITERIA

## GENERAL DESCRIPTION

---

### • Abnormality Judgment

Judge NG when the malfunction criteria below are completed.

### • Judgment Value

Malfunction Criteria	Threshold Value
Integrated times of the condition reaching follows, • DVFLMAX $\geq$ 0.88 V • SUMVFL $\geq$ 14.08 V DVFLMAX is max. value of sensor output during 12.8 seconds. SUMVFL is cumulative value of sensor output deviation during 12.8 seconds.	$\geq$ 4 times

**Time Needed for Diagnosis:** 12.8 seconds  $\times$  4 times

**Malfunction Indicator Light Illumination:** Illuminates when malfunction occurs in 2 continuous driving cycles.

### • Normality Judgment

Judge OK and clear the NG when all the malfunction criteria below are completed.

### • Judgment Value

Malfunction Criteria	Threshold Value
DVFLMAX	$<$ 0.88 V
SUMVFL	$<$ 14.08 V

## 5. DTC CLEAR CONDITION

- When the OK idling cycle is completed 40 times in a row
- When "Clear Memory" was performed

## 6. MALFUNCTION INDICATOR LIGHT CLEAR CONDITION

- When the OK driving cycle is completed 3 times in a row
- When "Clear Memory" was performed

## 7. FAIL SAFE

None

## 8. ECM OPERATION AT DTC SETTING

Memorize the freeze frame data. (For test mode \$02)

# DIAGNOSTIC TROUBLE CODE (DTC) DETECTING CRITERIA

GENERAL DESCRIPTION

---

MEMO:

# DIAGNOSTIC TROUBLE CODE (DTC) DETECTING CRITERIA

## GENERAL DESCRIPTION

### BJ:DTC P0483 — COOLING FAN RATIONALITY CHECK —

#### 1. OUTLINE OF DIAGNOSIS

Detect the malfunction of radiator fan.

Judge NG when the engine coolant temperature decreases slowly even if the radiator fan started rotating.

#### 2. ENABLE CONDITION

Secondary Parameters	Enable Conditions
Engine coolant temperature	$\geq 100^{\circ}\text{C}$ ( $212^{\circ}\text{F}$ )

#### 3. GENERAL DRIVING CYCLE

Perform the diagnosis continuously when the engine coolant temperature is very high (more than  $100^{\circ}\text{C}$  ( $212^{\circ}\text{F}$ )).

#### 4. DIAGNOSTIC METHOD

Check the engine coolant temperature (A/D value) when the radiator fan is ON since the radiator fan output turns from OFF to ON with all of the malfunction conditions below completed.

Secondary Parameters	Enable Conditions
Engine speed	600 — 900 rpm
Idle switch	ON
Vehicle speed	0 km/h (0 MPH)
Battery voltage	$\geq 10.9$ V

Judge NG when the cumulative time until completing the malfunction criteria below becomes more than the time (5 minutes) needed for diagnosis. Also Judge OK when the malfunction criteria below is not completed. And then clear NG.

#### Judgment Value

Malfunction Criteria	Threshold Value
Radiator fan signal switching	OFF to ON
Engine coolant temperature	$\geq 105^{\circ}\text{C}$ ( $221^{\circ}\text{F}$ )
Engine coolant temperature	Not decreased

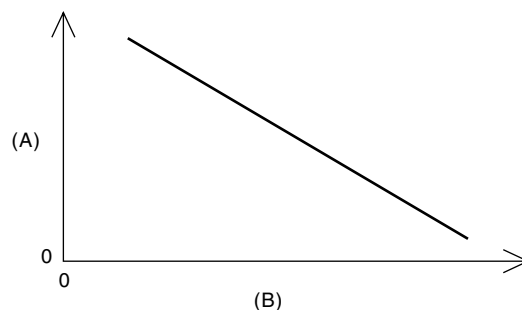

EN-01737

(A) Engine coolant temperature  $^{\circ}\text{C}$   
( $^{\circ}\text{F}$ )

(B) A/D value (V)



# DIAGNOSTIC TROUBLE CODE (DTC) DETECTING CRITERIA

GENERAL DESCRIPTION

---

**Time Needed for Diagnosis:** 5 minutes

**Malfunction Indicator Light Illumination:** Illuminates when malfunction occurs in 2 continuous driving cycles.

## 5. DTC CLEAR METHOD

- When the OK idling cycle was completed 40 times in a row
- When "Clear Memory" was performed

## 6. MALFUNCTION INDICATOR LIGHT CLEAR CONDITION

- When the OK driving cycle was completed 3 times in a row
- When "Clear Memory" was performed

## 7. FAIL SAFE

None

## 8. ECM OPERATION AT DTC SETTING

Memorize the freeze frame data. (For test mode \$02)

# DIAGNOSTIC TROUBLE CODE (DTC) DETECTING CRITERIA

## GENERAL DESCRIPTION

### BK:DTC P0502 — VEHICLE SPEED SENSOR CIRCUIT LOW INPUT —

#### 1. OUTLINE OF DIAGNOSIS

- Detect the open or short circuit of vehicle speed.
- Judge NG when the vehicle speed is low while the vehicle speed is assumed to be high.

#### 2. ENABLE CONDITION

Secondary Parameters	Enable Conditions
None	

#### 3. GENERAL DRIVE CYCLE

Always perform the diagnosis continuously.

#### 4. DIAGNOSTIC METHOD

Judge NG when the time of completing the malfunction criteria below becomes more than time needed for diagnosis. Judge OK when the vehicle speed is more than 4 km/h (2.5 MPH) and less than 224 km/h (140 MPH).

##### Judgment Value

Malfunction Criteria	Threshold Value
<b>Low side diagnosis (1)</b>	
Cumulative time when the malfunction criteria below are completed	≥ 20 seconds
Idle switch	OFF
Injector pulse	≥ 2.5 milliseconds
Engine speed	≥ 2800 rpm
Neutral switch	OFF
Vehicle speed signals count (353 ms)	< 1

##### Time Needed for Diagnosis:

Low side                      20 seconds

**Malfunction Indicator Light Illumination:** Illuminates as soon as malfunction occurs.

#### 5. DTC CLEAR CONDITION

- When the OK idling cycle is completed 40 times in a row
- When “Clear Memory” was performed

#### 6. MALFUNCTION INDICATOR LIGHT CLEAR CONDITION

- When the OK driving cycle was completed 3 times in a row.
- When “Clear Memory” was performed

#### 7. FAIL SAFE

None

#### 8. ECM OPERATION AT DTC SETTING

Memorize the freeze frame data. (For test mode \$02)

# DIAGNOSTIC TROUBLE CODE (DTC) DETECTING CRITERIA

GENERAL DESCRIPTION

## BL:DTC P0503 — VEHICLE SPEED SENSOR INTERMITTENT/ERRATIC/HIGH —

### 1. OUTLINE OF DIAGNOSIS

- Detect the open or short circuit of vehicle speed.
- Judge NG when the vehicle speed is high while the vehicle speed is assumed to be low.

### 2. ENABLE CONDITION

Secondary Parameters	Enable Conditions
None	

### 3. GENERAL DRIVE CYCLE

Always perform the diagnosis continuously.

### 4. DIAGNOSTIC METHOD

Judge NG when the time of completing the malfunction criteria below becomes more than time needed for diagnosis. Judge OK when the vehicle speed is more than 4 km/h (2.5 MPH) and less than 224 km/h (140 MPH).

#### Judgment Value

Malfunction Criteria	Threshold Value
<b>High side diagnosis</b>	
Cumulative time when the malfunction criteria below are completed	≥ 5 seconds
Idle switch	OFF
Injector pulse	≤ 2.0 milliseconds
Engine speed	≤ 2100 rpm
Neutral switch	OFF
Vehicle speed signals count (353 ms)	≥ 56

#### Time Needed for Diagnosis:

High 5 seconds

**Malfunction Indicator Light Illumination:** Illuminates as soon as malfunction occurs.

### 5. DTC CLEAR CONDITION

- When the OK idling cycle is completed 40 times in a row
- When "Clear Memory" was performed

### 6. MALFUNCTION INDICATOR LIGHT CLEAR CONDITION

- When the OK driving cycle was completed 3 times in a row
- When "Clear Memory" was performed

### 7. FAIL SAFE

None

### 8. ECM OPERATION AT DTC SETTING

Memorize the freeze frame data. (For test mode \$02)

# DIAGNOSTIC TROUBLE CODE (DTC) DETECTING CRITERIA

## GENERAL DESCRIPTION

### BM:DTC P0506 — IDLE CONTROL SYSTEM RPM LOWER THAN EXPECTED —

#### 1. OUTLINE OF DIAGNOSIS

Detect the malfunction that the engine speed does not approach to the target engine speed at idling.  
Judge NG when the engine speed is lower than target engine speed and does not increase to target engine speed even though idle air control solenoid valve is opened.

#### 2. COMPONENT DESCRIPTION

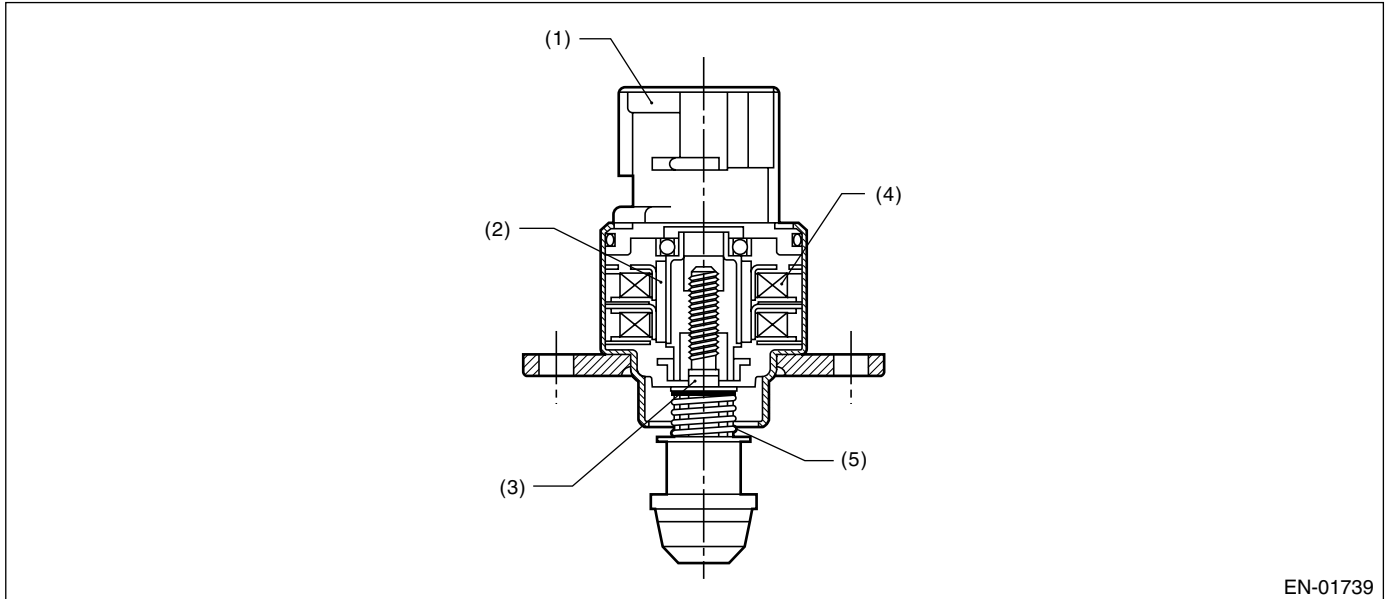

EN-01739

(1) Connector  
(2) Permanent magnet

(3) Shaft  
(4) Coil

(5) Spring

#### 3. ENABLE CONDITION

Secondary Parameters	Enable Conditions
Closed control in ISC	In operation
Dashpot function	0
Vehicle speed	= 0 km/h (0 MPH)
Coolant temperature	≥ 75°C (167°F)
Battery voltage	> 10.9 V
AT model or AT model neutral gear	

#### 4. GENERAL DRIVE CYCLE

Perform the diagnosis continuously at idling after warming up engine.

# DIAGNOSTIC TROUBLE CODE (DTC) DETECTING CRITERIA

GENERAL DESCRIPTION

## 5. DIAGNOSTIC METHOD

### • Abnormality Judgment

Judge NG when the continuous time until completing all the malfunction criteria below becomes more than the time (10 seconds) needed for diagnosis.

### • Judgment Value

Malfunction Criteria	Threshold Value
Actual – target engine speed	≤ 100 rpm

**Time Needed for Diagnosis:** 10 seconds

**Malfunction Indicator Light Illumination:** Illuminates when malfunction occurs in 2 continuous driving cycles.

### • Normality Judgment

Judge OK when the continuous time until completing the malfunction criteria below becomes more than time needed for diagnosis (2 seconds).

### • Judgment Value

Malfunction Criteria	Threshold Value
Actual – target engine speed	> 100 rpm

## 6. DTC CLEAR CONDITION

- When the OK idling cycle is completed 40 times in a row
- When “Clear Memory” was performed

## 7. MALFUNCTION INDICATOR LIGHT CLEAR CONDITION

- When the OK driving cycle was completed 3 times in a row
- When “Clear Memory” was performed

## 8. FAIL SAFE

None

## 9. ECM OPERATION AT DTC SETTING

Memorize the freeze frame data. (For test mode \$02)

# DIAGNOSTIC TROUBLE CODE (DTC) DETECTING CRITERIA

## GENERAL DESCRIPTION

### BN:DTC P0507 — IDLE CONTROL SYSTEM RPM HIGHER THAN EXPECTED —

#### 1. OUTLINE OF DIAGNOSIS

Detect the malfunction that the engine speed does not approach to the target engine speed at idling.  
Judge NG when the engine speed is higher than target engine speed and does not decrease to target engine speed even though idle air control solenoid valve is closed.

#### 2. COMPONENT DESCRIPTION

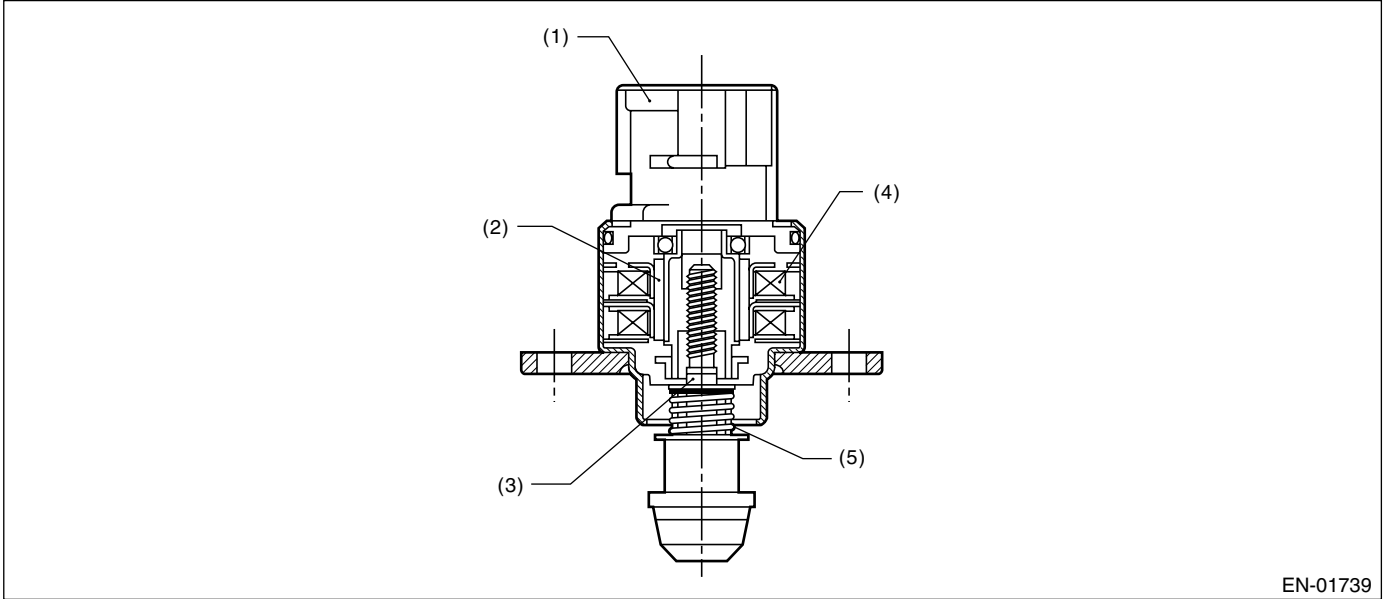

EN-01739

- (1) Connector
- (2) Permanent magnet
- (3) Shaft
- (4) Coil
- (5) Spring

#### 3. ENABLE CONDITION

Secondary Parameters	Enable Conditions
Closed control in ISC	In operation
Dashpot function	0
Vehicle speed	= 0 km/h (0 MPH)
Coolant temperature	$\geq 75^{\circ}\text{C}$ ( $167^{\circ}\text{F}$ )
Battery voltage	$> 10.9\text{ V}$
AT model or AT model neutral gear	

#### 4. GENERAL DRIVE CYCLE

Perform the diagnosis continuously at idling after warming up engine.

# DIAGNOSTIC TROUBLE CODE (DTC) DETECTING CRITERIA

GENERAL DESCRIPTION

## 5. DIAGNOSTIC METHOD

### • Abnormality Judgment

Judge NG when the continuous time until completing all the malfunction criteria below becomes more than the time (10 seconds) needed for diagnosis.

### • Judgment Value

Malfunction Criteria	Threshold Value
Actual – target engine speed	$\geq 200$ rpm

**Time Needed for Diagnosis:** 10 seconds

**Malfunction Indicator Light Illumination:** Illuminates when malfunction occurs in 2 continuous driving cycles.

### • Normality Judgment

Judge OK when the continuous time until completing all the malfunction criteria below becomes more than the time (2 seconds) needed for diagnosis.

### • Judgment Value

Malfunction Criteria	Threshold Value
Actual – target engine speed	$< 200$ rpm

## 6. DTC CLEAR CONDITION

- When the OK idling cycle is completed 40 times in a row
- When “Clear Memory” was performed

## 7. MALFUNCTION INDICATOR LIGHT CLEAR CONDITION

- When the OK driving cycle was completed 3 times in a row
- When “Clear Memory” was performed

## 8. FAIL SAFE

None

## 9. ECM OPERATION AT DTC SETTING

Memorize the freeze frame data. (For test mode \$02)

# DIAGNOSTIC TROUBLE CODE (DTC) DETECTING CRITERIA

## GENERAL DESCRIPTION

---

### BO:DTC P0512 — STARTER REQUEST CIRCUIT —

#### 1. OUTLINE OF DIAGNOSIS

Detect the open/short circuit of starter switch.

Judge ON NG when the starter signal remains OFF after starting engine from engine stall condition.

#### 2. ENABLE CONDITION

Secondary Parameters	Enable Conditions
Engine	Run

#### 3. GENERAL DRIVING CYCLE

Always perform diagnosis continuously after starting engine.

#### 4. DIAGNOSTIC METHOD

Judge NG when completing the malfunction criteria below. Judge OK and clear the NG when the starter switch is turned to ON.

##### Judgment Value

Malfunction Criteria	Threshold Value
Engine speed	$\geq 0$ — 700 rpm
Vehicle speed	$\geq 0$ km/h (0 MPH)
Starter "ON" signal	Not detected

##### Time Needed for Diagnosis:

ON side                      1 second

**Malfunction Indicator Light Illumination:** Illuminates when malfunction occurs in 2 continuous driving cycles.

#### 5. DTC CLEAR CONDITION

- When the OK idling cycle is completed 40 times in a row
- When "Clear Memory" was performed

#### 6. MALFUNCTION INDICATOR LIGHT CLEAR CONDITION

- When the OK driving cycle was completed 3 times in a row
- When "Clear Memory" was performed

#### 7. FAIL SAFE

None

#### 8. ECM OPERATION AT DTC SETTING

Memorize the freeze frame data. (For test mode \$02)



# DIAGNOSTIC TROUBLE CODE (DTC) DETECTING CRITERIA

GENERAL DESCRIPTION

## BP:DTC P0519 — IDLE CONTROL SYSTEM MALFUNCTION (FAIL-SAFE) —

### 1. OUTLINE OF DIAGNOSIS

- Detect the malfunction of engine speed increase at idling.
- Judge NG when the engine speed is higher than and too far from the target engine speed.

### 2. ENABLE CONDITION

Secondary Parameters	Enable Conditions
Dashpot function at closed idle control	0

### 3. GENERAL DRIVE CYCLE

Always perform the diagnosis continuously at idle speed.

### 4. DIAGNOSTIC METHOD

#### • Abnormality Judgment

Judge NG when the cumulative time until completing the malfunction criteria below becomes more than the time needed for diagnosis.

#### • Judgment Value

Malfunction Criteria	Threshold Value
Actual – target engine speed	$\geq 800$ rpm
ISC closed loop compensation value	= MIN value

**Time Needed for Diagnosis:** 1 second

**Malfunction Indicator Light Illumination:** Illuminates as soon as malfunction occurs.

#### • Normality Judgment

Judge OK when one of the malfunction criteria below is completed.

#### • Judgment Value

Malfunction Criteria	Threshold Value
ISC closed loop compensation value	$\neq$ MIN value
Cumulative time (actual – target engine speed) < 100 rpm	$\geq 2$ seconds
Cumulative time (engine speed < target idle speed)	$\geq 2$ seconds

### 5. DTC CLEAR CONDITION

- When the OK idling cycle is completed 40 times in a row
- When “Clear Memory” was performed

### 6. MALFUNCTION INDICATOR LIGHT CLEAR CONDITION

- When the OK driving cycle was completed 3 times in a row
- When “Clear Memory” was performed

### 7. FAIL SAFE

Cut the fuel of all cylinders, #1 cylinder or #1, #2 cylinder according to throttle position, engine speed, vehicle speed.

### 8. ECM OPERATION AT DTC SETTING

Memorize the freeze frame data. (For test mode \$02)

# DIAGNOSTIC TROUBLE CODE (DTC) DETECTING CRITERIA

## GENERAL DESCRIPTION

---

### BQ:DTC P0565 — CRUISE CONTROL ON SIGNAL —

#### 1. OUTLINE OF DIAGNOSIS

Judge NG when the vehicle speed is less than 20 km/h (12 MPH) and cruise control set signal remains ON for limited time.

#### 2. ENABLE CONDITION

Secondary Parameters	Enable Conditions
Vehicle speed	≤ 20 km/h (12 MPH)

#### 3. GENERAL DRIVING CYCLE

Perform the diagnosis with less than 20 km/h (12 MPH) vehicle speed.

#### 4. DIAGNOSTIC METHOD

##### Judgment Value

Malfunction Criteria	Threshold Value
Canceling signal	No signal

**Time Needed for Diagnosis:** 10 seconds

**Malfunction Indicator Light Illumination:** Illuminates when malfunction occurs in 2 continuous driving cycles.

#### 5. DTC CLEAR CONDITION

- When the OK idling cycle was completed 40 times in a row
- When "Clear Memory" was performed

#### 6. MALFUNCTION INDICATOR LIGHT CLEAR CONDITION

- When the OK driving cycle was completed 3 times in a row
- When "Clear Memory" was performed

#### 7. FAIL SAFE

None

#### 8. ECM OPERATION AT DTC SETTING

Memorize the freeze frame data. (For test mode \$02)

# DIAGNOSTIC TROUBLE CODE (DTC) DETECTING CRITERIA

GENERAL DESCRIPTION

## BR:DTC P0604 — INTERNAL CONTROL MODULE RANDOM ACCESS MEMORY (RAM) ERROR —

### 1. OUTLINE OF DIAGNOSIS

- Detect the malfunction of micro-computer (RAM).
- Zero clear the all normal RAM on initial routine, and judge NG when the sum of cleared RAM is not “0”.

### 2. ENABLE CONDITION

Perform the diagnosis without condition by initial routine.

### 3. GENERAL DRIVING CYCLE

Perform the diagnosis only once immediately after the IG key is turned to ON.

### 4. DIAGNOSTIC METHOD

Judge NG when the malfunction criteria below are completed, and judge OK at the IG key turned to ON.

#### Judgment Value

Malfunction Criteria	Threshold Value
Sum on RAM data after data cleared operation	Not to zero

**Time Needed for Diagnosis:** Not determined

**Malfunction Indicator Light Illumination:** Illuminates as soon as malfunction occurs.

### 5. DTC CLEAR CONDITION

- When the OK idling cycle is completed 40 times in a row
- When “Clear Memory” was performed

### 6. MALFUNCTION INDICATOR LIGHT CLEAR CONDITION

- When the OK driving cycle is completed 3 times in a row
- When “Clear Memory” was performed

### 7. FAIL SAFE

None

### 8. ECM OPERATION AT DTC SETTING

Memorize the freeze frame data. (For test mode \$02)

# DIAGNOSTIC TROUBLE CODE (DTC) DETECTING CRITERIA

## GENERAL DESCRIPTION

---

### BS:DTC P0691 — COOLING FAN 1 CONTROL CIRCUIT LOW —

#### 1. OUTLINE OF DIAGNOSIS

- Detect the open/short circuit of radiator fan circuit.
- Judge NG when the ECM output level and the actual terminal level are different.

#### 2. ENABLE CONDITION

Secondary Parameters	Enable Conditions
Engine speed	≥ 500 rpm
Battery voltage	≥ 8 V
After engine starting	1 second or more
Ignition switch	ON

#### 3. GENERAL DRIVING CYCLE

Always perform the diagnosis continuously after starting the engine.

#### 4. DIAGNOSTIC METHOD

Judge NG when the continuous time until completing the malfunction criteria below becomes more than the time (2.5 seconds) needed for diagnosis, and also judge OK when the malfunction criteria below is not completed. And then clear NG.

##### Judgment Value

Malfunction Criteria	Threshold Value
Terminal voltage level when ECM transmits OFF signal	Low level

**Time Needed for Diagnosis:** 2.5 seconds

**Malfunction Indicator Light Illumination:** Illuminates when malfunction occurs in 2 continuous driving cycles.

#### 5. DTC CLEAR CONDITION

- When the OK idling cycle was completed 40 times in a row
- When “Clear Memory” was performed

#### 6. MALFUNCTION INDICATOR LIGHT CLEAR CONDITION

- When the OK driving cycle was completed 3 times in a row
- When “Clear Memory” was performed

#### 7. FAIL SAFE

None

#### 8. ECM OPERATION AT DTC SETTING

Memorize the freeze frame data. (For test mode \$02)

# DIAGNOSTIC TROUBLE CODE (DTC) DETECTING CRITERIA

GENERAL DESCRIPTION

## BT:DTC P0692 — COOLING FAN 1 CONTROL CIRCUIT HIGH —

### 1. OUTLINE OF DIAGNOSIS

- Detect the open/short circuit of radiator fan circuit.
- Judge NG when the ECM output level and the actual terminal level are different.

### 2. ENABLE CONDITION

Secondary Parameters	Enable Conditions
Engine speed	≥ 500 rpm
Battery voltage	≥ 8 V
After engine starting	1 second or more
Ignition switch	ON

### 3. GENERAL DRIVING CYCLE

Always perform the diagnosis continuously after starting the engine.

### 4. DIAGNOSTIC METHOD

Judge NG when the continuous time until completing the malfunction criteria below becomes more than the time (2.5 seconds) needed for diagnosis, and also judge OK when the malfunction criteria below is not completed. And then clear NG.

#### Judgment Value

Malfunction Criteria	Threshold Value
Terminal voltage level when ECM transmits ON signal	High level

**Time Needed for Diagnosis:** 2.5 seconds

**Malfunction Indicator Light Illumination:** Illuminates when malfunction occurs in 2 continuous driving cycles.

### 5. DTC CLEAR CONDITION

- When the OK idling cycle was completed 40 times in a row
- When "Clear Memory" was performed

### 6. MALFUNCTION INDICATOR LIGHT CLEAR CONDITION

- When the OK driving cycle was completed 3 times in a row
- When "Clear Memory" was performed

### 7. FAIL SAFE

None

### 8. ECM OPERATION AT DTC SETTING

Memorize the freeze frame data. (For test mode \$02)

# DIAGNOSTIC TROUBLE CODE (DTC) DETECTING CRITERIA

## GENERAL DESCRIPTION

---

### BU:DTC P0703 — TORQUE CONVERTER/BRAKE SWITCH “B” CIRCUIT —

#### 1. OUTLINE OF DIAGNOSIS

Judge NG when the AT break SW circuit is battery short, ground short or open.

#### 2. ENABLE CONDITION

Secondary Parameters	Enable Conditions
Vehicle speed change	30 to 0 km/h (18.6 to 0 MPH) 0 to 30 km/h (0 to 18.6 MPH)

#### 3. GENERAL DRIVING CYCLE

Perform diagnosis from 30 to 0 km/h (from 18.6 to 0 MPH) of vehicle speed.

Perform diagnosis from 0 to 30 km/h (from 0 to 18.6 MPH) of vehicle speed.

#### 4. DIAGNOSTIC METHOD

##### Judgment Value

Malfunction Criteria	Threshold Value
ON signal	No signal
OFF signal	No signal

**Time Needed for Diagnosis:** 150 times

**Malfunction Indicator Light Illumination:** Illuminates when malfunction occurs in 2 continuous driving cycles.

#### 5. DTC CLEAR CONDITION

- When the OK idling cycle was completed 40 times in a row
- When “Clear Memory” was performed

#### 6. MALFUNCTION INDICATOR LIGHT CLEAR CONDITION

- When the OK driving cycle was completed 3 times in a row
- When “Clear Memory” was performed

#### 7. FAIL SAFE

None

#### 8. ECM OPERATION AT DTC SETTING

Memorize the freeze frame data. (For test mode \$02)

## BV:DTC P0705 — TRANSMISSION RANGE SENSOR CIRCUIT (PRNDL INPUT)

### 1. OUTLINE OF DIAGNOSIS

Judge NG when the “D” range switch becomes ground short or open circuit.

### 2. COMPONENT DESCRIPTION

Inhibitor switch ensures the safety at engine start. This switch is installed to the right side of transmission case, and operated by selector lever. When the selector lever is in the “P” or “N” range, the engine will start because the electric circuit in inhibitor switch is closed and the starter circuit is connected. When the selector lever is in the “R”, “D”, “3”, “2” or “1” range, the electric circuit in inhibitor switch is open; therefore, the engine cannot be cranked. In the “R” range, the back-up light will illuminate because the back-up light circuit in the switch is connected. In addition to the functions above, the inhibitor switch has the circuit which detects the selected range position at the present and transmits the range signal to the TCM.

### 3. ENABLE CONDITION

- Enable condition A

Secondary Parameters	Enable Conditions
Shift	“N” to “3”
Vehicle speed	≥ 60 km/h (37 MPH)

- Enable condition B

Secondary Parameters	Enable Conditions
Engine speed	> 500 rpm
Battery voltage	> 10.9 V

### 4. GENERAL DRIVING CYCLE

Perform the diagnosis when shifting selector lever from Neutral to 3rd at vehicle speed of 60 km/h (37 MPH).  
(For Enable condition A)

Perform the diagnosis continuously after engine start (For Enable condition B).

### 5. DIAGNOSTIC METHOD

#### Judgment Value

Malfunction Criteria	Threshold Value
“D” signal continuously (For Enable condition A)	Not detected
Simultaneous signal (For Enable condition B)	≥ 2

#### Time Needed for Diagnosis:

- 63.75 seconds (For Enable condition A)
- 10 seconds (For Enable condition B)

**Malfunction Indicator Light Illumination:** Illuminates when malfunction occurs in 2 continuous driving cycles.

### 6. DTC CLEAR CONDITION

- When the OK idling cycle was completed 40 times in a row
- When “Clear Memory” was performed

### 7. MALFUNCTION INDICATOR LIGHT CLEAR CONDITION

- When the OK driving cycle was completed 3 times in a row
- When “Clear Memory” was performed

### 8. FAIL SAFE

None

# DIAGNOSTIC TROUBLE CODE (DTC) DETECTING CRITERIA

## GENERAL DESCRIPTION

---

### 9. ECM OPERATION AT DTC SETTING

Memorize the freeze frame data. (For test mode \$02)



# DIAGNOSTIC TROUBLE CODE (DTC) DETECTING CRITERIA

GENERAL DESCRIPTION

## BW:DTC P0710 — TRANSMISSION FLUID TEMPERATURE SENSOR CIRCUIT

### 1. OUTLINE OF DIAGNOSIS

- Judge NG when the ATF temperature sensor is open, battery short or ground short.
- Judge NG when the ATF sensor is detective.

### 2. COMPONENT DESCRIPTION

ATF temperature sensor is installed to the hydraulic control valve body of transmission as a unit with transmission harness. This sensor detects ATF temperature and outputs it as electric resistance signal.

### 3. ENABLE CONDITION

Secondary Parameters	Enable Conditions
None	

### 4. GENERAL DRIVING CYCLE

Always perform the diagnosis continuously.

### 5. DIAGNOSTIC METHOD

#### Judgment Value

Malfunction Criteria	Threshold Value
Output voltage	$\leq 0.1 \text{ V}$
Output at $\geq 80\text{km/h}$ (50 MPH) after 5 minutes from reaching more than 4.8 V	$\geq 4.7 \text{ V}$

**Time Needed for Diagnosis:** 63.75 seconds

**Malfunction Indicator Light Illumination:** Illuminates when malfunction occurs in 2 continuous driving cycles.

### 6. DTC CLEAR CONDITION

- When the OK idling cycle was completed 40 times in a row
- When "Clear Memory" was performed

### 7. MALFUNCTION INDICATOR LIGHT CLEAR CONDITION

- When the OK driving cycle was completed 3 times in a row
- When "Clear Memory" was performed

### 8. FAIL SAFE

Control ATF temperature at a constant temperature 80°C (176°F).

### 9. ECM OPERATION AT DTC SETTING

Memorize the freeze frame data. (For test mode \$02)

# DIAGNOSTIC TROUBLE CODE (DTC) DETECTING CRITERIA

## GENERAL DESCRIPTION

### **BX:DTC P0716 — INPUT/TURBINE SPEED SENSOR CIRCUIT RANGE/PERFORMANCE —**

#### **1. OUTLINE OF DIAGNOSIS**

Judge NG when the turbine speed signal is not transmitted for some reasons.

#### **2. COMPONENT DESCRIPTION**

Torque converter turbine speed sensor (output shaft speed sensor) is installed to the outside of transmission case. This sensor detects the turbine speed of torque converter by the peripheral speed of high clutch drum connected to input shaft. And then it transmits the sine wave signal (32 pulses per rev.) to TCM. TCM calculates the ratio of the input shaft speed to vehicle speed, and then makes a judgment whether to shift or not.

#### **3. ENABLE CONDITION**

Secondary Parameters	Enable Conditions
Engine speed	≥ 1500 rpm
Vehicle speed	≥ 40 km/h (25 MPH)
Range switch	“D”, “3”, “2” or “1”

#### **4. GENERAL DRIVING CYCLE**

Perform the diagnosis at engine speed of more than 1,500 rpm and vehicle speed of more than 40 km/h (25 MPH).

#### **5. DIAGNOSTIC METHOD**

Perform the diagnosis when the conditions below were continued for 2 seconds.

- (1) Except “P”, “N”, “R” ranges and inhibitor switch is normal.
- (2) Engine speed is more than 3000 rpm.
- (3) Vehicle speed is 30 km/h (19 MPH) and vehicle speed sensor is normal.
- (4) Turbine speed is more than 600 rpm.

#### **Judgment Value**

Malfunction Criteria	Threshold Value
Output from turbine shaft speed	< 600 rpm

**Time Needed for Diagnosis:** Illuminates at occurrence of trouble

**Malfunction Indicator Light Illumination:** Illuminates when malfunction occurs in 2 continuous driving cycles.

#### **6. DTC CLEAR CONDITION**

- When the OK idling cycle was completed 40 times in a row
- When “Clear Memory” was performed

#### **7. MALFUNCTION INDICATOR LIGHT CLEAR CONDITION**

- When the OK driving cycle was completed 3 times in a row
- When “Clear Memory” was performed

#### **8. FAIL SAFE**

None

#### **9. ECM OPERATION AT DTC SETTING**

Memorize the freeze frame data. (For test mode \$02)

# DIAGNOSTIC TROUBLE CODE (DTC) DETECTING CRITERIA

GENERAL DESCRIPTION

## BY:DTC P0720 — OUTPUT SPEED SENSOR CIRCUIT —

### 1. OUTLINE OF DIAGNOSIS

Judge NG when an abnormal large signal is input to the front vehicle speed sensor, or no signal is input to the rear vehicle speed sensor.

### 2. COMPONENT DESCRIPTION

This vehicle speed sensor (output shaft speed sensor) is installed to the outside of transmission case. This sensor detects the front wheel speed, and transmits the sine wave signal (16 pulses per rev.) to TCM. TCM converts the signal to pulse signal, and transmits to both of the ECM and the combination meter.

### 3. ENABLE CONDITION

Secondary Parameters	Enable Conditions
Vehicle speed	≥ 20 km/h (12 MPH)

### 4. GENERAL DRIVING CYCLE

Perform the diagnosis continuously with more than 20 km/h (12 MPH) vehicle speed.

### 5. DIAGNOSTIC METHOD

#### Judgment Value

Malfunction Criteria	Threshold Value
Number of vehicle speed sensor signals per 1 second	≥ 4698 or no signal

**Time Needed for Diagnosis:** 63.75 seconds

**Malfunction Indicator Light Illumination:** Illuminates when malfunction occurs in 2 continuous driving cycles.

### 6. DTC CLEAR CONDITION

- When the OK idling cycle was completed 40 times in a row
- When "Clear Memory" was performed

### 7. MALFUNCTION INDICATOR LIGHT CLEAR CONDITION

- When the OK driving cycle was completed 3 times in a row
- When "Clear Memory" was performed

### 8. FAIL SAFE

- Use the normal vehicle speed sensor signal when either of them is normal.
- Use the vehicle speed calculated from the current gear position and turbine speed when both front and rear wheels are troubled.

### 9. ECM OPERATION AT DTC SETTING

Memorize the freeze frame data. (For test mode \$02)

# DIAGNOSTIC TROUBLE CODE (DTC) DETECTING CRITERIA

## GENERAL DESCRIPTION

---

### **BZ:DTC P0726 — ENGINE SPEED INPUT CIRCUIT RANGE/PERFORMANCE —**

#### **1. OUTLINE OF DIAGNOSIS**

Judge NG when the engine speed is not input in the status of running the engine.

#### **2. COMPONENT DESCRIPTION**

Engine speed sensor is installed to the outside of engine body and crank part. This sensor detects the crank speed, and transmits the sine wave signal (2 pulses per rev.) to TCM.

#### **3. ENABLE CONDITION**

Secondary Parameters	Enable Conditions
Output from mass air flow sensor	$\geq 1.0$ V

#### **4. GENERAL DRIVING CYCLE**

Perform the diagnosis continuously after engine start.

#### **5. DIAGNOSTIC METHOD**

##### **Judgment Value**

Malfunction Criteria	Threshold Value
Engine speed	$\leq 400$ rpm

**Time Needed for Diagnosis:** 63.75 seconds

**Malfunction Indicator Light Illumination:** Illuminates when malfunction occurs in 2 continuous driving cycles.

#### **6. DTC CLEAR CONDITION**

- When the OK idling cycle was completed 40 times in a row
- When "Clear Memory" was performed

#### **7. MALFUNCTION INDICATOR LIGHT CLEAR CONDITION**

- When the OK driving cycle was completed 3 times in a row
- When "Clear Memory" was performed

#### **8. FAIL SAFE**

None

#### **9. ECM OPERATION AT DTC SETTING**

Memorize the freeze frame data. (For test mode \$02)

# DIAGNOSTIC TROUBLE CODE (DTC) DETECTING CRITERIA

GENERAL DESCRIPTION

## CA:DTC P0731 — GEAR 1 INCORRECT RATIO —

### 1. OUTLINE OF DIAGNOSIS

Judge NG when the expected present gear is different from the actual gear.

### 2. ENABLE CONDITION

Secondary Parameters	Enable Conditions
Throttle angle	≥ 15°
Vehicle speed	≥ 10 km/h (6 MPH)
Range switch	“D”, “3”, “2” or “1”
Upshift or downshift events	Not in operation

### 3. GENERAL DRIVING CYCLE

Continuously perform the diagnosis while depressing accelerator pedal with more than 10 km/h (6 MPH) vehicle speed.

### 4. DIAGNOSTIC METHOD

Perform the diagnosis when the conditions below are not completed for more than 40 milliseconds on normal control.

- (1) Vehicle speed is more than 10 km/h (6 MPH).
- (2) Throttle sensor is more than a certain angle.
- (3) Shifted to “D”, “3”, “2” or “1” range, and range signal is normal.
- (4) More than 1 second passed after shift change finished.

#### Judgment Value

Malfunction Criteria	Threshold Value
GR / (1st gear ratio) Where, GR = (vehicle speed sensor 1 output) / (turbine shaft speed sensor output)	> 110% or < 90%

**Time Needed for Diagnosis:** 3 seconds

**Malfunction Indicator Light Illumination:** Illuminates when malfunction occurs in 2 continuous driving cycles.

### 5. DTC CLEAR CONDITION

- When the OK idling cycle was completed 40 times in a row
- When “Clear Memory” was performed

### 6. MALFUNCTION INDICATOR LIGHT CLEAR CONDITION

- When the OK driving cycle was completed 3 times in a row
- When “Clear Memory” was performed

### 7. FAIL SAFE

None

### 8. ECM OPERATION AT DTC SETTING

Memorize the freeze frame data. (For test mode \$02)

# DIAGNOSTIC TROUBLE CODE (DTC) DETECTING CRITERIA

## GENERAL DESCRIPTION

### CB:DTC P0732 — GEAR 2 INCORRECT RATIO —

#### 1. OUTLINE OF DIAGNOSIS

Judge NG when the expected present gear is different from the actual gear.

#### 2. ENABLE CONDITION

Secondary Parameters	Enable Conditions
Throttle angle	≥ 15°
Vehicle speed	≥ 10 km/h (6 MPH)
Range switch	“D”, “3”, “2” or “1”
Upshift or downshift events	Not in operation

#### 3. GENERAL DRIVING CYCLE

Continuously perform the diagnosis while depressing accelerator pedal with more than 10 km/h (6 MPH) vehicle speed.

#### 4. DIAGNOSTIC METHOD

Perform the diagnosis when the conditions below are not completed for more than 40 milliseconds on normal control.

- (1) Vehicle speed is more than 10 km/h (6 MPH).
- (2) Throttle sensor is more than a certain angle.
- (3) Shifted to “D”, “3”, “2” or “1” range, and range signal is normal.
- (4) More than 1 second passed after shift change finished.

#### Judgment Value

Malfunction Criteria	Threshold Value
GR / (2nd gear ratio) Where, GR = (vehicle speed sensor 1 output) / (turbine shaft speed sensor output)	> 110% or < 90%

**Time Needed for Diagnosis:** 3 seconds

**Malfunction Indicator Light Illumination:** Illuminates when malfunction occurs in 2 continuous driving cycles.

#### 5. DTC CLEAR CONDITION

- When the OK idling cycle was completed 40 times in a row
- When “Clear Memory” was performed

#### 6. MALFUNCTION INDICATOR LIGHT CLEAR CONDITION

- When the OK driving cycle was completed 3 times in a row
- When “Clear Memory” was performed

#### 7. FAIL SAFE

None

#### 8. ECM OPERATION AT DTC SETTING

Memorize the freeze frame data. (For test mode \$02)

# DIAGNOSTIC TROUBLE CODE (DTC) DETECTING CRITERIA

GENERAL DESCRIPTION

## CC:DTC P0733 — GEAR 3 INCORRECT RATIO —

### 1. OUTLINE OF DIAGNOSIS

Judge NG when the expected present gear is different from the actual gear.

### 2. ENABLE CONDITION

Secondary Parameters	Enable Conditions
Throttle angle	$\geq 15^\circ$
Vehicle speed	$\geq 10$ km/h (6 MPH)
Range switch	"D", "3", "2" or "1"
Upshift or downshift events	Not in operation

### 3. GENERAL DRIVING CYCLE

Continuously perform the diagnosis while depressing accelerator pedal with more than 10 km/h (6 MPH) vehicle speed.

### 4. DIAGNOSTIC METHOD

Perform the diagnosis when the conditions below are not completed for more than 40 milliseconds on normal control.

- (1) Vehicle speed is more than 10 km/h (6 MPH).
- (2) Throttle sensor is more than a certain angle.
- (3) Shifted to "D", "3", "2" or "1" range, and range signal is normal.
- (4) More than 1 second passed after shift change finished.

#### Judgment Value

Malfunction Criteria	Threshold Value
GR / (3rd gear ratio) Where, GR = (vehicle speed sensor 1 output) / (turbine shaft speed sensor output)	$> 110\%$ or $< 90\%$

**Time Needed for Diagnosis:** 3 seconds

**Malfunction Indicator Light Illumination:** Illuminates when malfunction occurs in 2 continuous driving cycles.

### 5. DTC CLEAR CONDITION

- When the OK idling cycle was completed 40 times in a row
- When "Clear Memory" was performed

### 6. MALFUNCTION INDICATOR LIGHT CLEAR CONDITION

- When the OK driving cycle was completed 3 times in a row
- When "Clear Memory" was performed

### 7. FAIL SAFE

None

### 8. ECM OPERATION AT DTC SETTING

Memorize the freeze frame data. (For test mode \$02)

# DIAGNOSTIC TROUBLE CODE (DTC) DETECTING CRITERIA

## GENERAL DESCRIPTION

---

### CD:DTC P0734 — GEAR 4 INCORRECT RATIO —

#### 1. OUTLINE OF DIAGNOSIS

Judge NG when the expected present gear is different from the actual gear.

#### 2. ENABLE CONDITION

Secondary Parameters	Enable Conditions
Throttle angle	≥ 15°
Vehicle speed	≥ 10 km/h (6 MPH)
Range switch	“D”, “3”, “2” or “1”
Upshift or downshift events	Not in operation

#### 3. GENERAL DRIVING CYCLE

Continuously perform the diagnosis while depressing accelerator pedal with more than 10 km/h (6 MPH) vehicle speed.

#### 4. DIAGNOSTIC METHOD

Perform the diagnosis when the conditions below are not completed for more than 40 milliseconds on normal control.

- (1) Vehicle speed is more than 10 km/h (6 MPH).
- (2) Throttle sensor is more than a certain angle.
- (3) Shifted to “D”, “3”, “2” or “1” range, and range signal is normal.
- (4) More than 1 second passed after shift change finished.

#### Judgment Value

Malfunction Criteria	Threshold Value
GR / (4th gear ratio) Where, GR = (vehicle speed sensor 1 output) / (turbine shaft speed sensor output)	> 110% or < 90%

**Time Needed for Diagnosis:** 3 seconds

**Malfunction Indicator Light Illumination:** Illuminates when malfunction occurs in 2 continuous driving cycles.

#### 5. DTC CLEAR CONDITION

- When the OK idling cycle was completed 40 times in a row
- When “Clear Memory” was performed

#### 6. MALFUNCTION INDICATOR LIGHT CLEAR CONDITION

- When the OK driving cycle was completed 3 times in a row
- When “Clear Memory” was performed

#### 7. FAIL SAFE

None

#### 8. ECM OPERATION AT DTC SETTING

Memorize the freeze frame data. (For test mode \$02)



# DIAGNOSTIC TROUBLE CODE (DTC) DETECTING CRITERIA

GENERAL DESCRIPTION

## CE:DTC P0741 — TORQUE CONVERTER CLUTCH CIRCUIT PERFORMANCE OR STUCK OFF —

### 1. OUTLINE OF DIAGNOSIS

Judge NG when the engine speed is different from the turbine speed for some reasons at AT lock-up.

### 2. ENABLE CONDITION

Secondary Parameters	Enable Conditions
In 4th gear position, duty ratio for duty solenoid valve	$\geq 90\%$

### 3. GENERAL DRIVING CYCLE

Perform the diagnosis at 4th gear lock-up.

### 4. DIAGNOSTIC METHOD

#### Judgment Value

Malfunction Criteria	Threshold Value
Engine speed $\geq$ (output shaft speed $\times$ 4th gear ratio $\times 9/8$ )	

**Time Needed for Diagnosis:** 10.2 seconds

**Malfunction Indicator Light Illumination:** Illuminates when malfunction occurs in 2 continuous driving cycles.

### 5. DTC CLEAR CONDITION

- When the OK idling cycle was completed 40 times in a row
- When "Clear Memory" was performed

### 6. MALFUNCTION INDICATOR LIGHT CLEAR CONDITION

- When the OK driving cycle was completed 3 times in a row
- When "Clear Memory" was performed

### 7. FAIL SAFE

Not allowed to lock up.

### 8. ECM OPERATION AT DTC SETTING

Memorize the freeze frame data. (For test mode \$02)

# DIAGNOSTIC TROUBLE CODE (DTC) DETECTING CRITERIA

## GENERAL DESCRIPTION

---

### CF:DTC P0743 — TORQUE CONVERTER CLUTCH CIRCUIT ELECTRICAL —

#### 1. OUTLINE OF DIAGNOSIS

Judge NG when the lock-up duty solenoid becomes battery short, ground short or open circuit.

#### 2. COMPONENT DESCRIPTION

Lock-up duty solenoid is installed to the transmission hydraulic control valve body. The duty ratio is controlled by the signal from TCM. This allows the lock-up clutch to be connected or released smoothly by controlling the lock-up control valve.

#### 3. ENABLE CONDITION

Secondary Parameters	Enable Conditions
None	

#### 4. GENERAL DRIVING CYCLE

Always perform the diagnosis continuously.

#### 5. DIAGNOSTIC METHOD

##### Judgment Value

Malfunction Criteria	Threshold Value
Vc at "ON" signal from ECM	Low level
Vc at "OFF" signal from ECM	High level

**Time Needed for Diagnosis:** 0.14 seconds

**Malfunction Indicator Light Illumination:** Illuminates when malfunction occurs in 2 continuous driving cycles.

#### 6. DTC CLEAR CONDITION

- When the OK idling cycle was completed 40 times in a row
- When "Clear Memory" was performed

#### 7. MALFUNCTION INDICATOR LIGHT CLEAR CONDITION

- When the OK driving cycle was completed 3 times in a row
- When "Clear Memory" was performed

#### 8. FAIL SAFE

None

#### 9. ECM OPERATION AT DTC SETTING

Memorize the freeze frame data. (For test mode \$02)

# DIAGNOSTIC TROUBLE CODE (DTC) DETECTING CRITERIA

GENERAL DESCRIPTION

## CG:DTC P0748 — PRESSURE CONTROL SOLENOID “A” ELECTRICAL —

### 1. OUTLINE OF DIAGNOSIS

Judge NG when the line pressure duty solenoid becomes battery short, ground short or open circuit.

### 2. COMPONENT DESCRIPTION

Line pressure duty solenoid is installed to the transmission hydraulic control valve body. The duty ratio is controlled by the signal from TCM. This allows controlling the pressure modifier valve and accumulator control valve A, and allows the line pressure to be adjusted to the pressure appropriate for driving condition.

### 3. ENABLE CONDITION

Secondary Parameters	Enable Conditions
None	

### 4. GENERAL DRIVING CYCLE

Always perform the diagnosis continuously.

### 5. DIAGNOSTIC METHOD

#### Judgment Value

Malfunction Criteria	Threshold Value
Vc at “ON” signal from ECM	Low
Vc at “OFF” signal from ECM	High

**Time Needed for Diagnosis:** 0.14 seconds

**Malfunction Indicator Light Illumination:** Illuminates when malfunction occurs in 2 continuous driving cycles.

### 6. DTC CLEAR CONDITION

- When the OK idling cycle was completed 40 times in a row
- When “Clear Memory” was performed

### 7. MALFUNCTION INDICATOR LIGHT CLEAR CONDITION

- When the OK driving cycle was completed 3 times in a row
- When “Clear Memory” was performed

### 8. FAIL SAFE

Control the shift to be fixed in 3rd gear.

### 9. ECM OPERATION AT DTC SETTING

Memorize the freeze frame data. (For test mode \$02)

# DIAGNOSTIC TROUBLE CODE (DTC) DETECTING CRITERIA

## GENERAL DESCRIPTION

---

### CH:DTC P0753 — SHIFT SOLENOID “A” ELECTRICAL —

#### 1. OUTLINE OF DIAGNOSIS

Judge NG when the shift solenoid 1 becomes battery short, ground short or open circuit.

#### 2. COMPONENT DESCRIPTION

Shift solenoid 1 Shift solenoid is installed to the transmission hydraulic control valve body. This solenoid is switched on or off by the signal from TCM. Gear positions will change depending on the solenoid condition which is ON or OFF.

#### 3. ENABLE CONDITION

Secondary Parameters	Enable Conditions
None	

#### 4. GENERAL DRIVING CYCLE

Always perform the diagnosis continuously.

#### 5. DIAGNOSTIC METHOD

##### Judgment Value

Malfunction Criteria	Threshold Value
Collector voltage of transistor (Vc) for solenoid valve is inconsistent with signal from ECM	

**Time Needed for Diagnosis:** 30 milliseconds

**Malfunction Indicator Light Illumination:** Illuminates when malfunction occurs in 2 continuous driving cycles.

#### 6. DTC CLEAR CONDITION

- When the OK idling cycle was completed 40 times in a row
- When “Clear Memory” was performed

#### 7. MALFUNCTION INDICATOR LIGHT CLEAR CONDITION

- When the OK driving cycle was completed 3 times in a row
- When “Clear Memory” was performed

#### 8. FAIL SAFE

Control the shift to be fixed in 3rd gear.

#### 9. ECM OPERATION AT DTC SETTING

Memorize the freeze frame data. (For test mode \$02)

# DIAGNOSTIC TROUBLE CODE (DTC) DETECTING CRITERIA

GENERAL DESCRIPTION

## CI: DTC P0758 — SHIFT SOLENOID “B” ELECTRICAL —

### 1. OUTLINE OF DIAGNOSIS

Judge NG when the shift solenoid 2 becomes battery short, ground short or open circuit.

### 2. COMPONENT DESCRIPTION

Shift solenoid 2 Shift solenoid is installed to the transmission hydraulic control valve body. This solenoid is switched on or off by the signal from TCM. Gear positions will change depending on the solenoid condition which is ON or OFF.

### 3. ENABLE CONDITION

Secondary Parameters	Enable Conditions
None	

### 4. GENERAL DRIVING CYCLE

Always perform the diagnosis continuously.

### 5. DIAGNOSTIC METHOD

#### Judgment Value

Malfunction Criteria	Threshold Value
Vc for solenoid valve is inconsistent with signal from ECM	

**Time Needed for Diagnosis:** 30 milliseconds

**Malfunction Indicator Light Illumination:** Illuminates when malfunction occurs in 2 continuous driving cycles.

### 6. DTC CLEAR CONDITION

- When the OK idling cycle was completed 40 times in a row
- When “Clear Memory” was performed

### 7. MALFUNCTION INDICATOR LIGHT CLEAR CONDITION

- When the OK driving cycle was completed 3 times in a row
- When “Clear Memory” was performed

### 8. FAIL SAFE

Control the shift to be fixed in 3rd gear.

### 9. ECM OPERATION AT DTC SETTING

Memorize the freeze frame data. (For test mode \$02)

# DIAGNOSTIC TROUBLE CODE (DTC) DETECTING CRITERIA

## GENERAL DESCRIPTION

---

### CJ:DTC P0771 — SHIFT SOLENOID “E” PERFORMANCE OR STUCK OFF —

#### 1. OUTLINE OF DIAGNOSIS

Judge NG when the low clutch timing solenoid becomes battery short, ground short or open circuit.

#### 2. COMPONENT DESCRIPTION

Low clutch timing solenoid Low clutch timing solenoid is installed to the transmission hydraulic control valve body. This solenoid is switched on or off by the signal from TCM. This allows controlling the low clutch timing valve B and reverse inhibitor valve.

#### 3. ENABLE CONDITION

Secondary Parameters	Enable Conditions
None	

#### 4. GENERAL DRIVING CYCLE

Always perform the diagnosis continuously.

#### 5. DIAGNOSTIC METHOD

##### Judgment Value

Malfunction Criteria	Threshold Value
Vc at “ON” signal from ECM	Low level
Vc at “OFF” signal from ECM	High level

**Time Needed for Diagnosis:** 30 milliseconds

**Malfunction Indicator Light Illumination:** Illuminates when malfunction occurs in 2 continuous driving cycles.

#### 6. DTC CLEAR CONDITION

- When the OK idling cycle was completed 40 times in a row
- When “Clear Memory” was performed

#### 7. MALFUNCTION INDICATOR LIGHT CLEAR CONDITION

- When the OK driving cycle was completed 3 times in a row
- When “Clear Memory” was performed

#### 8. FAIL SAFE

None

#### 9. ECM OPERATION AT DTC SETTING

Memorize the freeze frame data. (For test mode \$02)

# DIAGNOSTIC TROUBLE CODE (DTC) DETECTING CRITERIA

GENERAL DESCRIPTION

## CK:DTC P0778 — PRESSURE CONTROL SOLENOID “B” ELECTRICAL —

### 1. OUTLINE OF DIAGNOSIS

Judge NG when the 2-4 brake duty solenoid becomes battery short, ground short or open circuit.

### 2. COMPONENT DESCRIPTION

2-4 brake duty solenoid is installed to the transmission hydraulic control valve body. The duty ratio is controlled by the signal from TCM. This solenoid decreases the change gear shock by adjusting the 2-4 brake pressure during 2-4 brake operation.

### 3. ENABLE CONDITION

Secondary Parameters	Enable Conditions
None	

### 4. GENERAL DRIVING CYCLE

Always perform the diagnosis continuously.

### 5. DIAGNOSTIC METHOD

#### Judgment Value

Malfunction Criteria	Threshold Value
Vc at “ON” signal from ECM	Low level
Vc at “OFF” signal from ECM	High level

**Time Needed for Diagnosis:** 0.14 seconds

**Malfunction Indicator Light Illumination:** Illuminates when malfunction occurs in 2 continuous driving cycles.

### 6. DTC CLEAR CONDITION

- When the OK idling cycle was completed 40 times in a row
- When “Clear Memory” was performed

### 7. MALFUNCTION INDICATOR LIGHT CLEAR CONDITION

- When the OK driving cycle was completed 3 times in a row
- When “Clear Memory” was performed

### 8. FAIL SAFE

Control the shift to be fixed in 3rd gear.

### 9. ECM OPERATION AT DTC SETTING

Memorize the freeze frame data. (For test mode \$02)

# DIAGNOSTIC TROUBLE CODE (DTC) DETECTING CRITERIA

## GENERAL DESCRIPTION

---

### CL:DTC P0785 — SHIFT/TIMING SOLENOID —

#### 1. OUTLINE OF DIAGNOSIS

Judge NG when the 2-4 brake timing solenoid becomes battery short, ground short or open circuit.

#### 2. COMPONENT DESCRIPTION

2-4 brake timing solenoid is installed to the transmission hydraulic control valve body. This solenoid is switched on or off by the signal from TCM. This allows controlling the 2-4 brake timing valve B and decreases the change gear shock.

#### 3. ENABLE CONDITION

Secondary Parameters	Enable Conditions
None	

#### 4. GENERAL DRIVING CYCLE

Always perform the diagnosis continuously.

#### 5. DIAGNOSTIC METHOD

##### Judgment Value

Malfunction Criteria	Threshold Value
Vc at "ON" signal from ECM	Low level
Vc at "OFF" signal from ECM	High level

**Time Needed for Diagnosis:** 30 milliseconds

**Malfunction Indicator Light Illumination:** Illuminates when malfunction occurs in 2 continuous driving cycles.

#### 6. DTC CLEAR CONDITION

- When the OK idling cycle was completed 40 times in a row
- When "Clear Memory" was performed

#### 7. MALFUNCTION INDICATOR LIGHT CLEAR CONDITION

- When the OK driving cycle was completed 3 times in a row
- When "Clear Memory" was performed

#### 8. FAIL SAFE

None

#### 9. ECM OPERATION AT DTC SETTING

Memorize the freeze frame data. (For test mode \$02)



# DIAGNOSTIC TROUBLE CODE (DTC) DETECTING CRITERIA

GENERAL DESCRIPTION

## CM:DTC P0851 — NEUTRAL SWITCH INPUT CIRCUIT LOW —

### 1. OUTLINE OF DIAGNOSIS

- Detect the open/short circuit of neutral switch.
- AT: Judge NG when ECM neutral terminal input is different from reception data from TCM.
- MT: Judge NG when the neutral switch does not respond even though shift lever is changed (neutral switch is turned on or off by vehicle and engine speed).

### 2. ENABLE CONDITION

Secondary Parameters	Enable Conditions
After engine starting	1 second or more
Starter switch	OFF
Battery voltage	≥ 8 V
Ignition switch	ON

### 3. GENERAL DRIVING CYCLE

Perform the diagnosis continuously after starting the engine.

### 4. DIAGNOSTIC METHOD

#### • Abnormality Judgment

AT: Judge NG when the continuous time of condition which satisfies the malfunction criteria below becomes more than time needed for diagnosis (5 seconds).

#### • Judgment Value

Malfunction Criteria	Threshold Value
Switch signal	ON (Low)
“P” range / “N” range on AT	OFF
Any other switches on AT	ON

#### • Normality Judgment

AT: Judge OK and clear the NG when the malfunction criteria below are completed.

#### • Judgment Value

Malfunction Criteria	Threshold Value
Switch signal	OFF (High)
“P” range / “N” range on AT	OFF
Any other switches on AT	ON

MT: Judge NG when the number of times until completing the malfunction criteria below continue 3 times in a row, judge OK when turning to OFF or ON.

#### • Judgment Value

Malfunction Criteria	Threshold Value
Neutral switch on MT	ON not detected
Driving condition change a) Vehicle speed = 0 km/h (0 MPH) & engine speed 600 — 900 rpm b) Vehicle speed 64 — 106 km/h (40 — 66 MPH) & engine speed 1600 — 2550 rpm	Change a) to b)

#### Time Needed for Diagnosis:

AT: Normal reception from AT is 5 seconds

MT: 3 monitoring on MT

**Malfunction Indicator Light Illumination:** Illuminates when malfunction occurs in 2 continuous driving cycles.

# DIAGNOSTIC TROUBLE CODE (DTC) DETECTING CRITERIA

## GENERAL DESCRIPTION

---

### 5. DTC CLEAR CONDITION

- When the OK idling cycle is completed 40 times in a row
- When "Clear Memory" was performed

### 6. MALFUNCTION INDICATOR LIGHT CLEAR CONDITION

- When the OK driving cycle was completed 3 times in a row
- When "Clear Memory" was performed

### 7. FAIL SAFE

None

### 8. ECM OPERATION AT DTC SETTING

Memorize the freeze frame data. (For test mode \$02)

# DIAGNOSTIC TROUBLE CODE (DTC) DETECTING CRITERIA

GENERAL DESCRIPTION

---

MEMO:

# DIAGNOSTIC TROUBLE CODE (DTC) DETECTING CRITERIA

## GENERAL DESCRIPTION

### CN:DTC P0852 — NEUTRAL SWITCH INPUT CIRCUIT HIGH —

#### 1. OUTLINE OF DIAGNOSIS

- Detect the open/short circuit of neutral switch.
- AT: Judge NG when ECM neutral terminal input is different from reception data from TCM.
- MT: Judge NG when the neutral switch does not respond even though shift lever is changed (neutral switch is turned on or off by vehicle and engine speed).

#### 2. ENABLE CONDITION

Secondary Parameters	Enable Conditions
After engine starting	1 second or more
Starter switch	Turn OFF
Battery voltage	≥ 8 V
Ignition switch	ON

#### 3. GENERAL DRIVING CYCLE

Perform the diagnosis continuously after starting the engine.

#### 4. DIAGNOSTIC METHOD

##### • Abnormality Judgement

AT: Judge NG when the continuous time of condition which satisfies the malfunction criteria below becomes more than time needed for diagnosis (5 seconds).

##### • Judgment Value

Malfunction Criteria	Threshold Value
Switch signal	OFF (High)
“P” range / “N” range on AT	ON
Any other switches on AT	OFF

##### • Normality Judgment

AT: Judge OK and clear the NG when the malfunction criteria below are completed.

##### • Judgment Value

Malfunction Criteria	Threshold Value
Switch signal	ON (Low)
“P” range / “N” range on AT	ON
Any other switches on AT	OFF

MT: Judge NG when the number of times until completing the malfunction criteria below continue 3 times in a row, judge OK when turning to OFF or ON.

##### • Judgment Value

Malfunction Criteria	Threshold Value
Neutral switch on MT	Not detected
Driving condition change a) Vehicle speed = 0 km/h (0 MPH) & engine speed 600 — 900 rpm b) Vehicle speed 64 — 106 km/h (40 — 66 MPH) & engine speed 1600 — 2550 rpm	Change a) to b)

##### Time Needed for Diagnosis:

AT: 5 seconds

MT: 3 monitoring on MT

**Malfunction Indicator Light Illumination:** Illuminates when malfunction occurs in 2 continuous driving cycles.

# DIAGNOSTIC TROUBLE CODE (DTC) DETECTING CRITERIA

GENERAL DESCRIPTION

---

## 5. DTC CLEAR CONDITION

- When the OK idling cycle is completed 40 times in a row
- When "Clear Memory" was performed

## 6. MALFUNCTION INDICATOR LIGHT CLEAR CONDITION

- When the OK driving cycle was completed 3 times in a row
- When "Clear Memory" was performed

## 7. FAIL SAFE

None

## 8. ECM OPERATION AT DTC SETTING

Memorize the freeze frame data. (For test mode \$02)

# DIAGNOSTIC TROUBLE CODE (DTC) DETECTING CRITERIA

## GENERAL DESCRIPTION

---

### CO:DTC P0864 — TCM COMMUNICATION CIRCUIT RANGE/PERFORMANCE —

#### 1. OUTLINE OF DIAGNOSIS

- Detect the communication malfunction of AT diagnosis.
- Judge NG when the communication format does not correspond.

#### 2. ENABLE CONDITION

Secondary Parameters	Enable Conditions
Battery voltage	≥ 8.0 V
Engine speed	≥ 500 rpm
Ignition switch	ON

#### 3. GENERAL DRIVING CYCLE

Perform the diagnosis continuously after starting the engine.

#### 4. DIAGNOSTIC METHOD

Judge NG when the continuous time communication format does not correspond continued for time needed for diagnosis. Judge OK and clear the NG when the communication format corresponds.

#### Judgment Value

Malfunction Criteria	Threshold Value
Incorrect pattern in wiring harness for communication	≥ 60 seconds

**Time Needed for Diagnosis:** 60 seconds

**Malfunction Indicator Light Illumination:** Illuminates when malfunction occurs in 2 continuous driving cycles.

#### 5. DTC CLEAR CONDITION

- When the OK idling cycle is completed 40 times in a row
- When “Clear Memory” was performed

#### 6. MALFUNCTION INDICATOR LIGHT CLEAR CONDITION

- When the OK driving cycle was completed 3 times in a row
- When “Clear Memory” was performed

#### 7. FAIL SAFE

None

#### 8. ECM OPERATION AT DTC SETTING

Memorize the freeze frame data. (For test mode \$02)

# DIAGNOSTIC TROUBLE CODE (DTC) DETECTING CRITERIA

GENERAL DESCRIPTION

## CP:DTC P0865 — TCM COMMUNICATION CIRCUIT LOW —

### 1. OUTLINE OF DIAGNOSIS

- Detect the open/short circuit of AT diagnosis line.
- Judge NG when the signal remains Low.

### 2. ENABLE CONDITION

Secondary Parameters	Enable Conditions
Battery voltage	≥ 8.0 V
Engine speed	≥ 500 rpm
Ignition switch	ON

### 3. GENERAL DRIVING CYCLE

Perform the diagnosis continuously after starting the engine.

### 4. DIAGNOSTIC METHOD

Judge NG when the malfunction criteria below are completed. Judge OK and clear the NG when the signal is turned over.

#### Judgment Value

Malfunction Criteria	Threshold Value
Continuous time of signal line low	≥ 3 seconds

**Time Needed for Diagnosis:** 3 seconds

**Malfunction Indicator Light Illumination:** Illuminates when malfunction occurs in 2 continuous driving cycles.

### 5. DTC CLEAR CONDITION

- When the OK idling cycle is completed 40 times in a row
- When "Clear Memory" was performed

### 6. MALFUNCTION INDICATOR LIGHT CLEAR CONDITION

- When the OK driving cycle was completed 3 times in a row
- When "Clear Memory" was performed

### 7. FAIL SAFE

None

### 8. ECM OPERATION AT DTC SETTING

Memorize the freeze frame data. (For test mode \$02)

# DIAGNOSTIC TROUBLE CODE (DTC) DETECTING CRITERIA

## GENERAL DESCRIPTION

---

### CQ:DTC P0866 — TCM COMMUNICATION CIRCUIT HIGH —

#### 1. OUTLINE OF DIAGNOSIS

- Detect the open/short circuit of AT diagnosis line.
- Judge NG when the signal remains High.

#### 2. ENABLE CONDITION

Secondary Parameters	Enable Conditions
Battery voltage	≥ 8.0 V
Engine speed	≥ 500 rpm
Ignition switch	ON

#### 3. GENERAL DRIVING CYCLE

Perform the diagnosis continuously after starting the engine.

#### 4. DIAGNOSTIC METHOD

Judge NG when the malfunction criteria below are completed. Judge OK and clear the NG when the signal is turned over.

##### Judgment Value

Malfunction Criteria	Threshold Value
Continuous time of signal line high	≥ 3 seconds

**Time Needed for Diagnosis:** 3 seconds

**Malfunction Indicator Light Illumination:** Illuminates when malfunction occurs in 2 continuous driving cycles.

#### 5. DTC CLEAR CONDITION

- When the OK idling cycle is completed 40 times in a row
- When "Clear Memory" was performed

#### 6. MALFUNCTION INDICATOR LIGHT CLEAR CONDITION

- When the OK driving cycle was completed 3 times in a row
- When "Clear Memory" was performed

#### 7. FAIL SAFE

None

#### 8. ECM OPERATION AT DTC SETTING

Memorize the freeze frame data. (For test mode \$02)



# DIAGNOSTIC TROUBLE CODE (DTC) DETECTING CRITERIA

GENERAL DESCRIPTION

## CR:DTC P1110 — ATMOSPHERIC PRESSURE SENSOR CIRCUIT MALFUNCTION (LOW INPUT) —

### 1. OUTLINE OF DIAGNOSIS

- Detect the open/short circuit of atmospheric pressure sensor.
- Judge NG when out of the standard value.

### 2. COMPONENT DESCRIPTION

Atmospheric pressure sensor is built in ECM.

### 3. ENABLE CONDITION

Secondary Parameters	Enable Conditions
Engine speed	$\geq 500$ rpm
Battery voltage	$\geq 10$ V
Ignition switch	ON

### 4. GENERAL DRIVING CYCLE

Always perform the diagnosis continuously.

### 5. DIAGNOSTIC METHOD

Judge NG when the continuous time until completing the malfunction criteria below becomes more than the time (2.5 seconds) needed for diagnosis. Judge fail safe NG when the continuous time until completing the malfunction criteria below becomes more than the time (0.1 seconds) needed for diagnosis. Judge OK and clear the NG when the malfunction criteria below are not completed.

#### Judgment Value

Malfunction Criteria	Threshold Value
Output voltage	$\leq 0.1$ V

**Time Needed for Diagnosis:** 2.5 seconds

**Malfunction Indicator Light Illumination:** Illuminates as soon as malfunction occurs.

### 6. DTC CLEAR CONDITION

- When the OK idling cycle is completed 40 times in a row
- When “Clear Memory” was performed

### 7. MALFUNCTION INDICATOR LIGHT CLEAR CONDITION

- When the OK driving cycle is completed 3 times in a row
- When “Clear Memory” was performed

### 8. FAIL SAFE

Make the atmospheric pressure 101 kPa (760 mmHg, 29.9 inHg).

### 9. ECM OPERATION AT DTC SETTING

Memorize the freeze frame data. (For test mode \$02)

# DIAGNOSTIC TROUBLE CODE (DTC) DETECTING CRITERIA

## GENERAL DESCRIPTION

---

### CS:DTC P1111 — ATMOSPHERIC PRESSURE SENSOR CIRCUIT MALFUNCTION (HIGH INPUT) —

#### 1. OUTLINE OF DIAGNOSIS

- Detect the open/short circuit of atmospheric pressure sensor.
- Judge NG when out of the standard value.

#### 2. COMPONENT DESCRIPTION

Atmospheric pressure sensor is built in ECM.

#### 3. ENABLE CONDITION

Secondary Parameters	Enable Conditions
Ignition switch	ON

#### 4. GENERAL DRIVING CYCLE

Always perform the diagnosis continuously.

#### 5. DIAGNOSTIC METHOD

Judge NG when the continuous time until completing the malfunction criteria below becomes more than the time (2.5 seconds) needed for diagnosis. Judge fail safe NG when the cumulative time until completing the malfunction criteria below becomes more than the time (0.1 seconds) needed for diagnosis. Judge OK and clear the NG when the malfunction criteria below are not completed.

##### Judgment Value

Malfunction Criteria	Threshold Value
Output voltage	$\geq 4.85$ V

**Time Needed for Diagnosis:** 2.5 seconds

**Malfunction Indicator Light Illumination:** Illuminates as soon as malfunction occurs.

#### 6. DTC CLEAR CONDITION

- When the OK idling cycle is completed 40 times in a row
- When “Clear Memory” was performed

#### 7. MALFUNCTION INDICATOR LIGHT CLEAR CONDITION

- When the OK driving cycle is completed 3 times in a row
- When “Clear Memory” was performed

#### 8. FAIL SAFE

Make the atmospheric pressure 101 kPa (760 mmHg, 29.9 inHg).

#### 9. ECM OPERATION AT DTC SETTING

Memorize the freeze frame data. (For test mode \$02)

# DIAGNOSTIC TROUBLE CODE (DTC) DETECTING CRITERIA

GENERAL DESCRIPTION

---

MEMO:

# DIAGNOSTIC TROUBLE CODE (DTC) DETECTING CRITERIA

## GENERAL DESCRIPTION

### CT:DTC P1134 — A/F SENSOR MICRO-COMPUTER PROBLEM —

#### 1. OUTLINE OF DIAGNOSIS

- Detect the malfunction of IC communication.
- Judge NG when the communication to front oxygen (A/F) sensor control IC is unable.

#### 2. COMPONENT DESCRIPTION

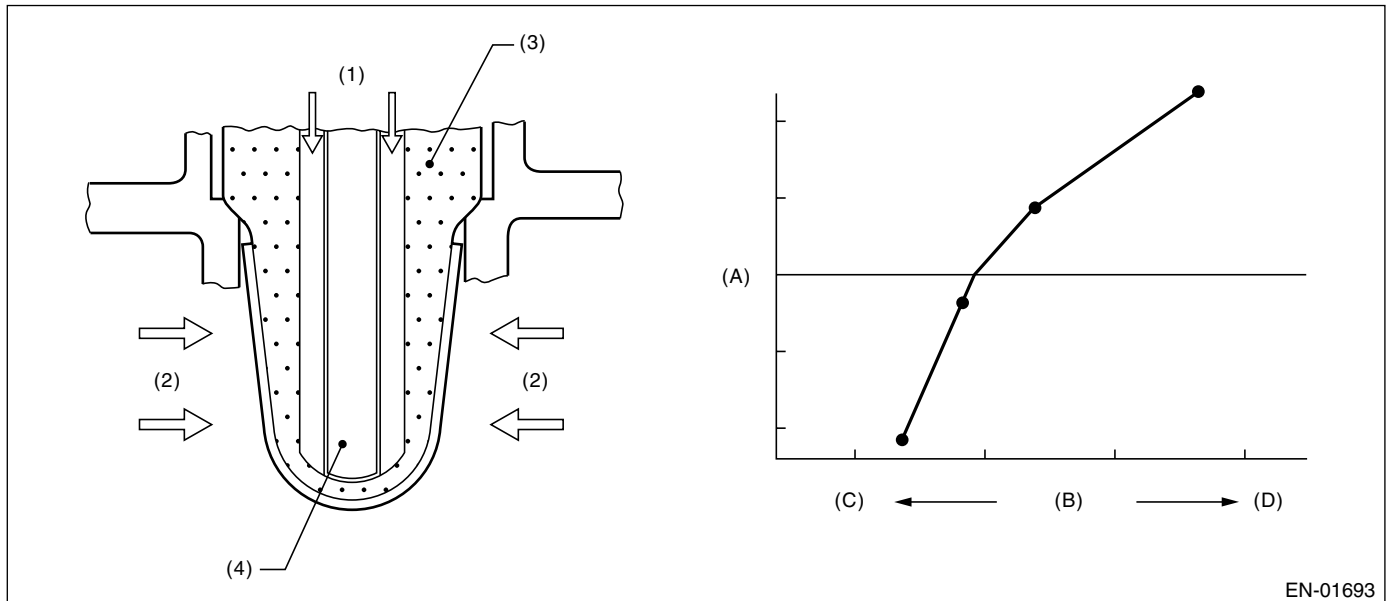

- |                      |                         |
|----------------------|-------------------------|
| (1) Atmosphere       | (A) Electromotive force |
| (2) Exhaust gas      | (B) Air fuel ratio      |
| (3) ZrO <sub>2</sub> | (C) Lean                |
| (4) Ceramic heater   | (D) Rich                |

#### 3. ENABLE CONDITION

Secondary Parameters	Enable Conditions
Battery voltage	≥ 10.9 V
After engine starting	≥ 140 seconds

#### 4. GENERAL DRIVING CYCLE

Perform the diagnosis continuously in 140 seconds after starting the engine.

# DIAGNOSTIC TROUBLE CODE (DTC) DETECTING CRITERIA

GENERAL DESCRIPTION

## 5. DIAGNOSTIC METHOD

### • Abnormality Judgment

Judge NG when the malfunction criteria below are completed.

### • Judgment Value

Malfunction Criteria	Threshold Value
Communication error to main CPU	≥ 250 times

**Time Needed for Diagnosis:** 12.5 seconds

**Malfunction Indicator Light Illumination:** Illuminates as soon as malfunction occurs.

### • Normality Judgment

Judge OK and clear the NG when the malfunction criteria below are completed.

### • Judgment Value

Malfunction Criteria	Threshold Value
Error	None

## 6. DTC CLEAR CONDITION

- When the OK idling cycle is completed 40 times in a row
- When "Clear Memory" was performed

## 7. MALFUNCTION INDICATOR LIGHT CLEAR CONDITION

- When the OK driving cycle is completed 3 times in a row
- When "Clear Memory" was performed

## 8. FAIL SAFE

None

## 9. ECM OPERATION AT DTC SETTING

Memorize the freeze frame data. (For test mode \$02)

# DIAGNOSTIC TROUBLE CODE (DTC) DETECTING CRITERIA

## GENERAL DESCRIPTION

### CU:DTC P1137 — O<sub>2</sub> SENSOR CIRCUIT LOW VOLTAGE (BANK 1 SENSOR 2) — Middle Electric Potential

#### 1. OUTLINE OF DIAGNOSIS

- Detect the output property malfunction of from oxygen (A/F) sensor.
- Judge NG when output voltage does not move to lean side or rich side.

#### 2. COMPONENT DESCRIPTION

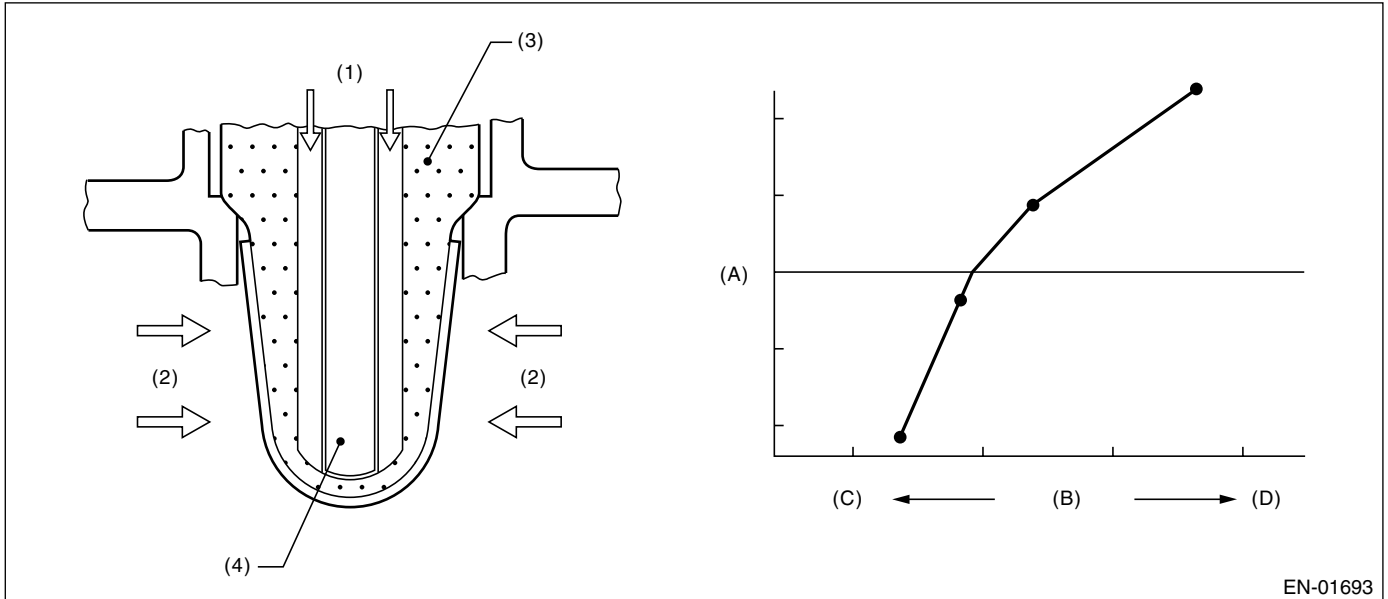

- |                      |                         |
|----------------------|-------------------------|
| (1) Atmosphere       | (A) Electromotive force |
| (2) Exhaust gas      | (B) Air fuel ratio      |
| (3) ZrO <sub>2</sub> | (C) Lean                |
| (4) Ceramic heater   | (D) Rich                |

#### 3. ENABLE CONDITION

Secondary Parameter	Enable Conditions
A/F sensor response diagnosis	Under diagnosis

#### 4. GENERAL DRIVING CYCLE

Perform the diagnosis just once in 225 seconds or more after starting the engine constantly at 76 km/h (47 MPH) of vehicle speed (Same as A/F sensor response diagnosis).

# DIAGNOSTIC TROUBLE CODE (DTC) DETECTING CRITERIA

GENERAL DESCRIPTION

## 5. DIAGNOSTIC METHOD

### • Abnormality Judgment

Judge NG when one of the malfunction criteria below is completed.

### • Judgment Value

Malfunction Criteria	Threshold Value
Continuous time of output voltage > 2.065 V ( $\lambda = 0.98$ )	3.4 seconds or more
Continuous time of output voltage < 2.180 V ( $\lambda = 1.0$ )	3.4 seconds or more

**Time needed for diagnosis:** 3.4 seconds

**Malfunction Indicator Light Illumination:** Illuminates as soon as malfunction occurs.

### • Normality Judgment

Judge OK when all the malfunction criteria below are completed.

### • Judgment Value

Malfunction Criteria	Threshold Value
Cumulative time of output voltage $\leq$ 2.065 V	0.2 seconds or more
Cumulative time of output voltage $\geq$ 2.180 V	0.2 seconds or more

## 6. DTC CLEAR CONDITION

- When the OK idling cycle was completed 40 times in a row
- When "Clear Memory" was performed

## 7. MALFUNCTION INDICATOR LIGHT CLEAR CONDITION

- When the OK driving cycle was completed 3 times in a row
- When "Clear Memory" was performed

## 8. FAIL SAFE

None

## 9. ECM OPERATION AT DTC SETTING

- Memorize the freeze frame data. (For test mode \$02)
- Memorize the diagnostic value and trouble standard value. (For test mode \$06)

# DIAGNOSTIC TROUBLE CODE (DTC) DETECTING CRITERIA

## GENERAL DESCRIPTION

### CV:DTC P1400 — FUEL TANK PRESSURE CONTROL SOLENOID VALVE CIRCUIT LOW —

#### 1. OUTLINE OF DIAGNOSIS

- Detect the open/short circuit of pressure control solenoid valve.
- Judge NG when ECM output level is different from actual terminal level.

#### 2. COMPONENT DESCRIPTION

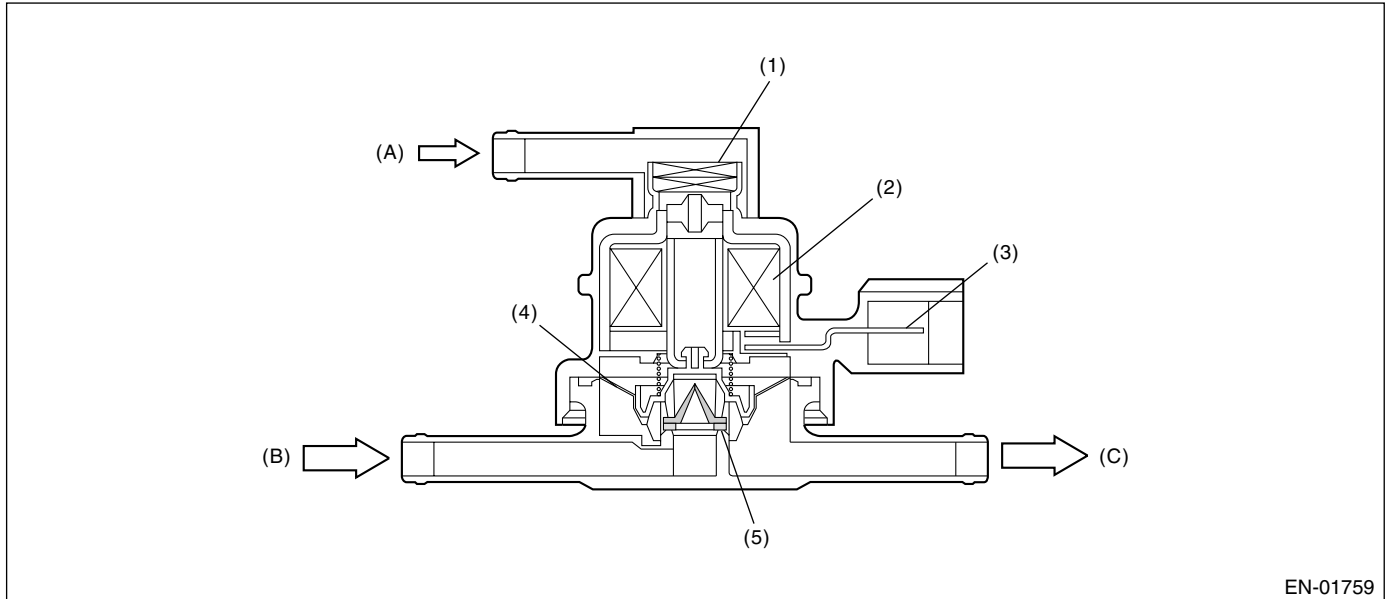

- |                        |               |                          |
|------------------------|---------------|--------------------------|
| (1) Filter             | (4) Diaphragm | (A) Atmospheric pressure |
| (2) Coil               | (5) Valve     | (B) Shut-off valve       |
| (3) Connector terminal |               | (C) To fuel tank         |

#### 3. ENABLE CONDITION

Secondary Parameters	Enable Conditions
Engine speed	$\geq 500$ rpm
Battery voltage	$\geq 8$ V
After engine starting	1 second or more
Ignition switch	ON

#### 4. GENERAL DRIVING CYCLE

Perform the diagnosis continuously after starting the engine.



# DIAGNOSTIC TROUBLE CODE (DTC) DETECTING CRITERIA

GENERAL DESCRIPTION

## 5. DIAGNOSTIC METHOD

### • Abnormality Judgment

Judge NG when the continuous time until completing the malfunction criteria below becomes more than time needed for diagnosis (2.5 seconds).

### • Judgment Value

Malfunction Criteria	Threshold Value
Terminal voltage when ECM outputs OFF signal	Low

**Time Needed for Diagnosis:** 2.5 seconds

**Malfunction Indicator Light Illumination:** Illuminates when malfunction occurs in 2 continuous driving cycles.

### • Normality Judgment

Judge OK and clear the NG when the malfunction criteria below are completed.

### • Judgment Value

Malfunction Criteria	Threshold Value
Terminal voltage when ECM outputs OFF signal	High

## 6. DTC CLEAR CONDITION

- When the OK idling cycle is completed 40 times in a row
- When "Clear Memory" was performed

## 7. MALFUNCTION INDICATOR LIGHT CLEAR CONDITION

- When the OK driving cycle was completed 3 times in a row
- When "Clear Memory" was performed

## 8. FAIL SAFE

None

## 9. ECM OPERATION AT DTC SETTING

Memorize the freeze frame data. (For test mode \$02)

# DIAGNOSTIC TROUBLE CODE (DTC) DETECTING CRITERIA

## GENERAL DESCRIPTION

### CW:DTC P1420 — FUEL TANK PRESSURE CONTROL SOLENOID VALVE CIRCUIT HIGH —

#### 1. OUTLINE OF DIAGNOSIS

- Detect the open/short circuit of pressure control solenoid valve.
- Judge NG when ECM output level is different from actual terminal level.

#### 2. COMPONENT DESCRIPTION

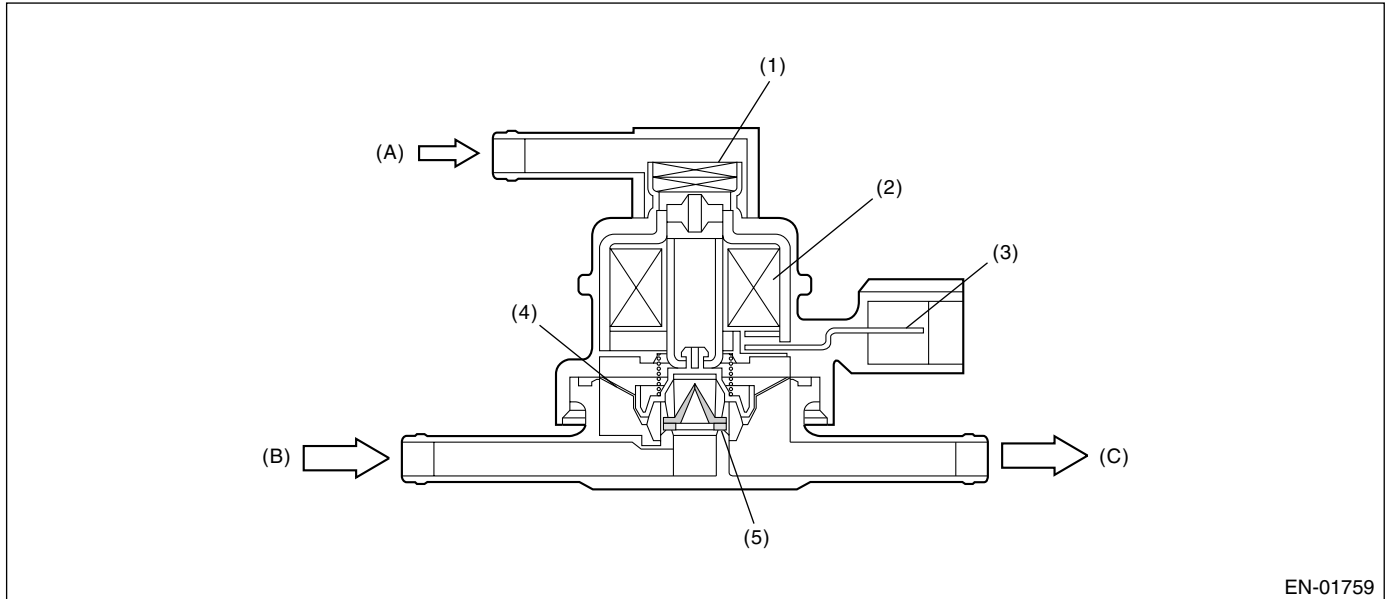

- |                        |               |                          |
|------------------------|---------------|--------------------------|
| (1) Filter             | (4) Diaphragm | (A) Atmospheric pressure |
| (2) Coil               | (5) Valve     | (B) Shut-off valve       |
| (3) Connector terminal |               | (C) To fuel tank         |

#### 3. ENABLE CONDITION

Secondary Parameters	Enable Conditions
Engine speed	$\geq 500$ rpm
Battery voltage	$\geq 8$ V
After engine starting	1 second or more
Ignition switch	ON

#### 4. GENERAL DRIVING CYCLE

Perform the diagnosis continuously after starting the engine.

# DIAGNOSTIC TROUBLE CODE (DTC) DETECTING CRITERIA

GENERAL DESCRIPTION

## 5. DIAGNOSTIC METHOD

### • Abnormality Judgment

Judge NG when the continuous time until completing the malfunction criteria below becomes more than time needed for diagnosis (2.5 seconds).

### • Judgment Value

Malfunction Criteria	Threshold Value
Terminal voltage when ECM outputs ON signal	High

**Time Needed for Diagnosis:** 2.5 seconds

**Malfunction Indicator Light Illumination:** Illuminates when malfunction occurs in 2 continuous driving cycles.

### • Normality Judgment

Judge OK and clear the NG when the malfunction criteria below are completed.

### • Judgment Value

Malfunction Criteria	Threshold Value
Terminal voltage when ECM outputs ON signal	Low

## 6. DTC CLEAR CONDITION

- When the OK idling cycle is completed 40 times in a row
- When "Clear Memory" was performed

## 7. MALFUNCTION INDICATOR LIGHT CLEAR CONDITION

- When the OK driving cycle was completed 3 times in a row
- When "Clear Memory" was performed

## 8. FAIL SAFE

None

## 9. ECM OPERATION AT DTC SETTING

Memorize the freeze frame data. (For test mode \$02)

# DIAGNOSTIC TROUBLE CODE (DTC) DETECTING CRITERIA

## GENERAL DESCRIPTION

### CX:DTC P1443 — VENT CONTROL SOLENOID VALVE FUNCTION PROBLEM —

#### 1. OUTLINE OF DIAGNOSIS

Detect vent control solenoid valve function problem (closed sticking). Judged NG when fuel tank pressure is low.

#### 2. ENABLE CONDITION

Secondary Parameters	Enable Conditions
Battery voltage	$\geq 10.9$ V
Atmospheric pressure	$\geq 75.7$ kPa (568 mmHg, 22.36 inHg)
Fuel tank pressure when engine starts	-0.7 — 1.5 kPa (-5 — 11 mmHg, -0.20 — 0.43 inHg)
Vent control solenoid valve	Open

#### 3. GENERAL DRIVING CYCLE

Always perform the diagnosis continuously.

#### 4. DIAGNOSTIC METHOD

##### • Abnormality Judgment

Judge NG when the continuous time of condition which satisfies the malfunction criteria below becomes more than time needed for diagnosis (3 seconds).

##### • Judgment Value

Malfunction Criteria	Threshold Value
Fuel tank pressure	$\leq -3.50$ kPa (-26.25 mmHg, -1.03 inHg)

Time Needed for Diagnosis:3 seconds

Malfunction Indicator Light Illumination: Illuminate when malfunction is detected.

##### • Normality Judgment

Judge OK when all the malfunction criteria below are completed, and then NG are cleared.

##### • Judgment Value

Malfunction Criteria	Threshold Value
Fuel tank pressure	$> -3.50$ kPa (-26.25 mmHg, -1.03 inHg)
Accumulation time when all satisfy the following conditions.	$\geq 305$
CPC duty ratio	$\neq 0$
Fuel temperature	-10 — 45°C (14 — 113°F)
Relative pressure of suction pipe	$\leq 26.7$ kPa (-200 mmHg, -7.87 inHg)

#### 5. DTC CLEAR CONDITION

- When the OK warm up cycle was completed 40 consecutive times
- When "Clear Memory" was performed

#### 6. MALFUNCTION INDICATOR LIGHT CLEAR CONDITION

- When the OK driving cycle was completed 3 consecutive times
- When "Clear Memory" was performed

#### 7. FAIL SAFE

PCV control: Open PCV solenoid valve

#### 8. ECM OPERATION AT DTC SETTING

Memorize the freeze frame data. (For test mode \$O2)

# DIAGNOSTIC TROUBLE CODE (DTC) DETECTING CRITERIA

GENERAL DESCRIPTION

---

MEMO:

# DIAGNOSTIC TROUBLE CODE (DTC) DETECTING CRITERIA

## GENERAL DESCRIPTION

### CY:DTC P1446 — FUEL TANK SENSOR CONTROL VALVE CIRCUIT LOW —

#### 1. OUTLINE OF DIAGNOSIS

- Detect the open/short circuit of fuel tank sensor control valve.
- Judge NG when the ECM output level is different from actual terminal level.

#### 2. COMPONENT DESCRIPTION

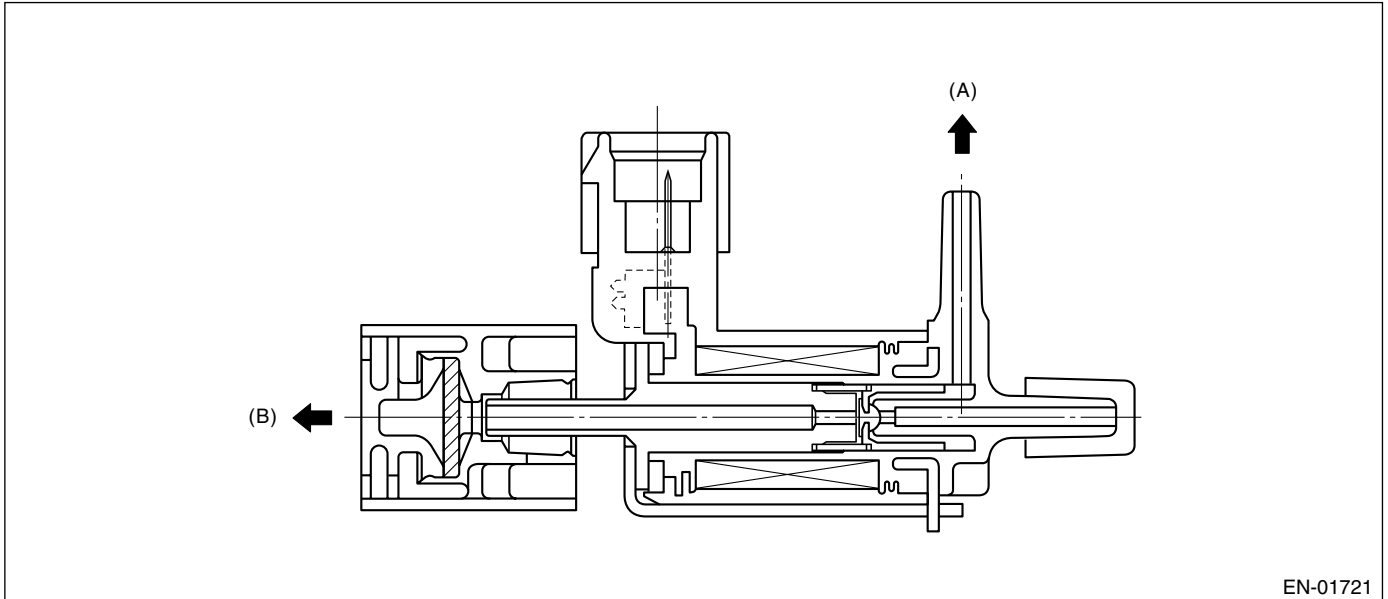

(A) Fuel tank pressure sensor

(B) External air

#### 3. ENABLE CONDITION

Secondary Parameters	Enable Conditions
Engine speed	$\geq 500$ rpm
Battery voltage	$\geq 8$ V
After engine starting	1 second or more
Ignition switch	ON

#### 4. GENERAL DRIVING CYCLE

Perform the diagnosis continuously after starting the engine.

#### 5. DIAGNOSTIC METHOD

Judge NG when the continuous time until completing the malfunction criteria below becomes more than the time (2.5 seconds) needed for diagnosis. Judge OK and clear the NG when the malfunction criteria are not completed.

##### Judgment Value

Malfunction Criteria	Threshold Value
Terminal voltage level when ECM sent OFF signals	Low level

**Time Needed for Diagnosis:** 2.5 seconds

**Malfunction Indicator Light Illumination:** Illuminates when malfunction occurs in 2 continuous driving cycles.

#### 6. DTC CLEAR CONDITION

- When the OK idling cycle is completed 40 times in a row
- When "Clear Memory" was performed

# DIAGNOSTIC TROUBLE CODE (DTC) DETECTING CRITERIA

GENERAL DESCRIPTION

---

## 7. MALFUNCTION INDICATOR LIGHT CLEAR CONDITION

- When the OK driving cycle is completed 3 times in a row
- When "Clear Memory" was performed

## 8. FAIL SAFE

None

## 9. ECM OPERATION AT DTC SETTING

Memorize the freeze frame data. (For test mode \$02)

# DIAGNOSTIC TROUBLE CODE (DTC) DETECTING CRITERIA

## GENERAL DESCRIPTION

### CZ:DTC P1447 — FUEL TANK SENSOR CONTROL VALVE CIRCUIT HIGH —

#### 1. OUTLINE OF DIAGNOSIS

- Detect the open/short circuit of fuel tank sensor control valve.
- Judge NG when the ECM output level is different from actual terminal level.

#### 2. COMPONENT DESCRIPTION

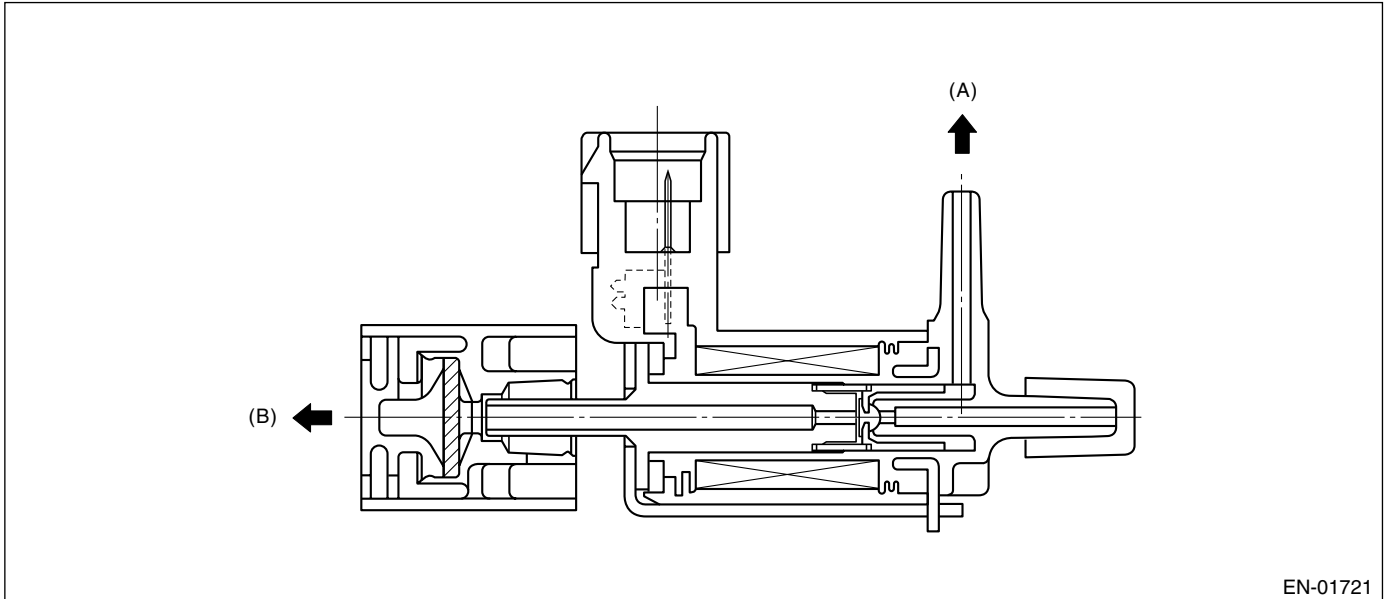

EN-01721

(A) Fuel tank pressure sensor

(B) External air

#### 3. ENABLE CONDITION

Secondary Parameters	Enable Conditions
Engine speed	$\geq 500$ rpm
Battery voltage	$\geq 8$ V
After engine starting	1 second or more
Ignition switch	ON

#### 4. GENERAL DRIVING CYCLE

Perform the diagnosis continuously after starting the engine.

#### 5. DIAGNOSTIC METHOD

Judge NG when the continuous time until completing the malfunction criteria below becomes more than the time (2.5 seconds) needed for diagnosis. Judge OK and clear the NG when the malfunction criteria are not completed.

##### Judgment Value

Malfunction Criteria	Threshold Value
Terminal voltage level when ECM sent ON signals	High level

**Time Needed for Diagnosis:** 2.5 seconds

**Malfunction Indicator Light Illumination:** Illuminates when malfunction occurs in 2 continuous driving cycles.

#### 6. DTC CLEAR CONDITION

- When the OK idling cycle is completed 40 times in a row
- When "Clear Memory" was performed



# DIAGNOSTIC TROUBLE CODE (DTC) DETECTING CRITERIA

GENERAL DESCRIPTION

---

## 7. MALFUNCTION INDICATOR LIGHT CLEAR CONDITION

- When the OK driving cycle is completed 3 times in a row
- When "Clear Memory" was performed

## 8. FAIL SAFE

None

## 9. ECM OPERATION AT DTC SETTING

Memorize the freeze frame data. (For test mode \$02)

# DIAGNOSTIC TROUBLE CODE (DTC) DETECTING CRITERIA

## GENERAL DESCRIPTION

### DA:DTC P1448 — FUEL TANK SENSOR CONTROL VALVE RANGE/PERFORMANCE—

#### 1. OUTLINE OF DIAGNOSIS

Detect the tank pressure switching solenoid function abnormality.

The tank pressure sensor is a relative pressure sensor, which normally compares the pressure with the atmospheric pressure. The tank pressure switching solenoid is a solenoid, which shifts the compare space from opening to closed during the EVAP diagnosis. Detect the malfunction that the compare space remains closed. (Not judge NG after enable condition completed but assume NG before enable condition completed.)

#### • Normality Judgment

Judge OK when the fuel tank pressure does not change (or changes by less than 0.67 kPa (5 mmHg, 0.2 inHg)) at atmospheric pressure changing by 0.67 kPa (5 mmHg, 0.2 inHg) or more per 80 seconds.

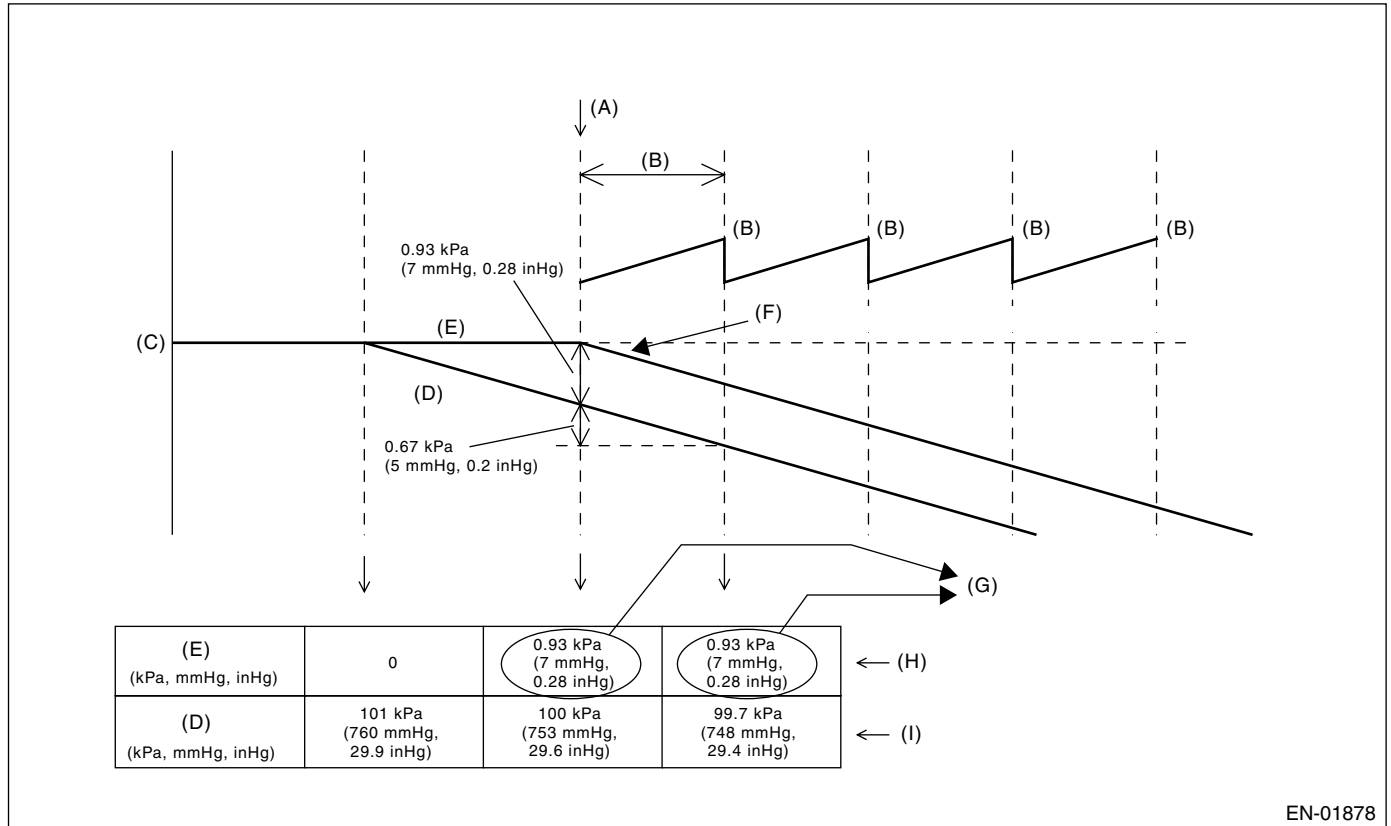

# DIAGNOSTIC TROUBLE CODE (DTC) DETECTING CRITERIA

GENERAL DESCRIPTION

## • Abnormality Judgment

Judge NG temporarily when the fuel tank pressure changes by 0.67 kPa (5 mmHg, 0.2 inHg) or more at atmospheric pressure changing by 0.67 kPa (5 mmHg, 0.2 inHg) or more per 80 seconds, and then judge NG when the previous condition is completed 5 times in a row.

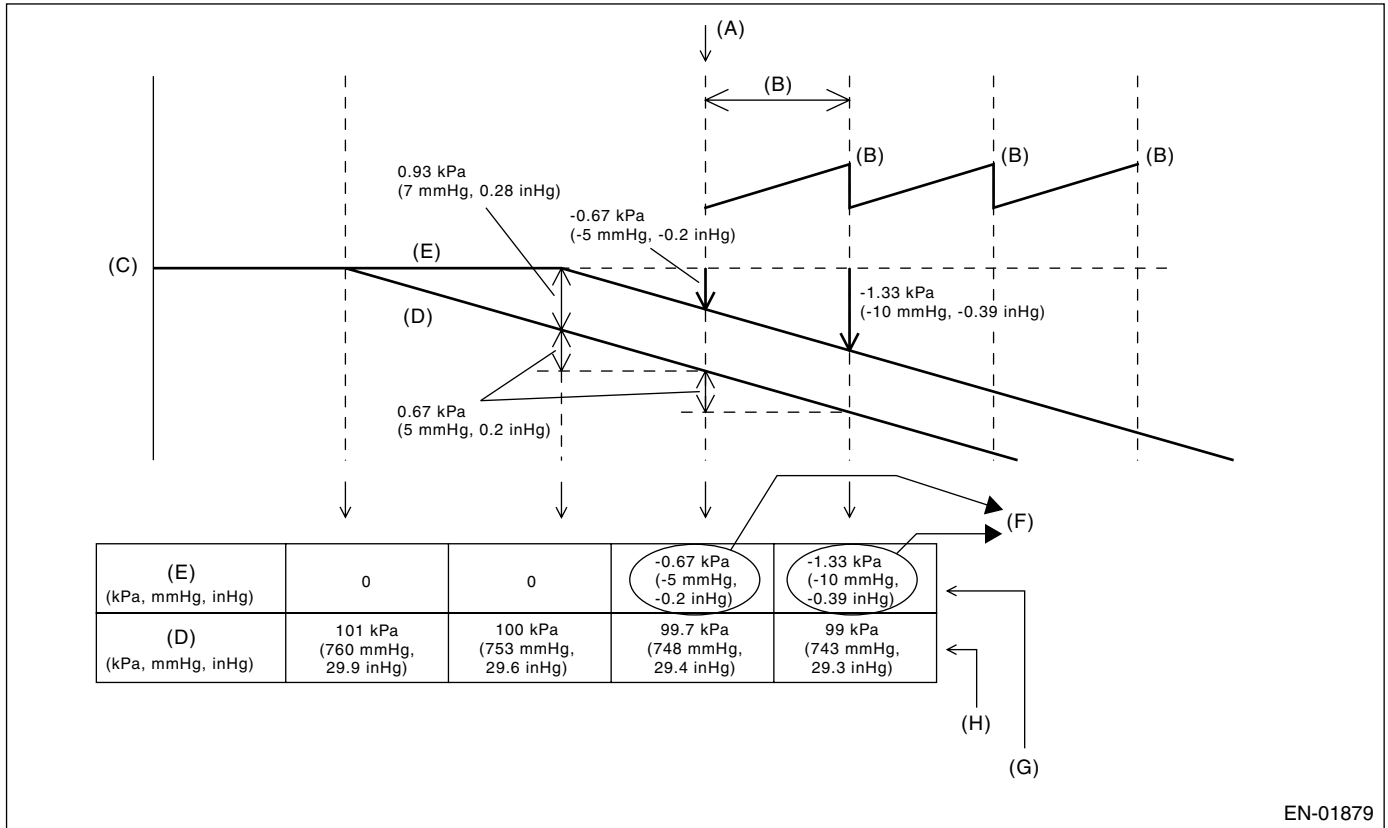

## 2. COMPONENT DESCRIPTION

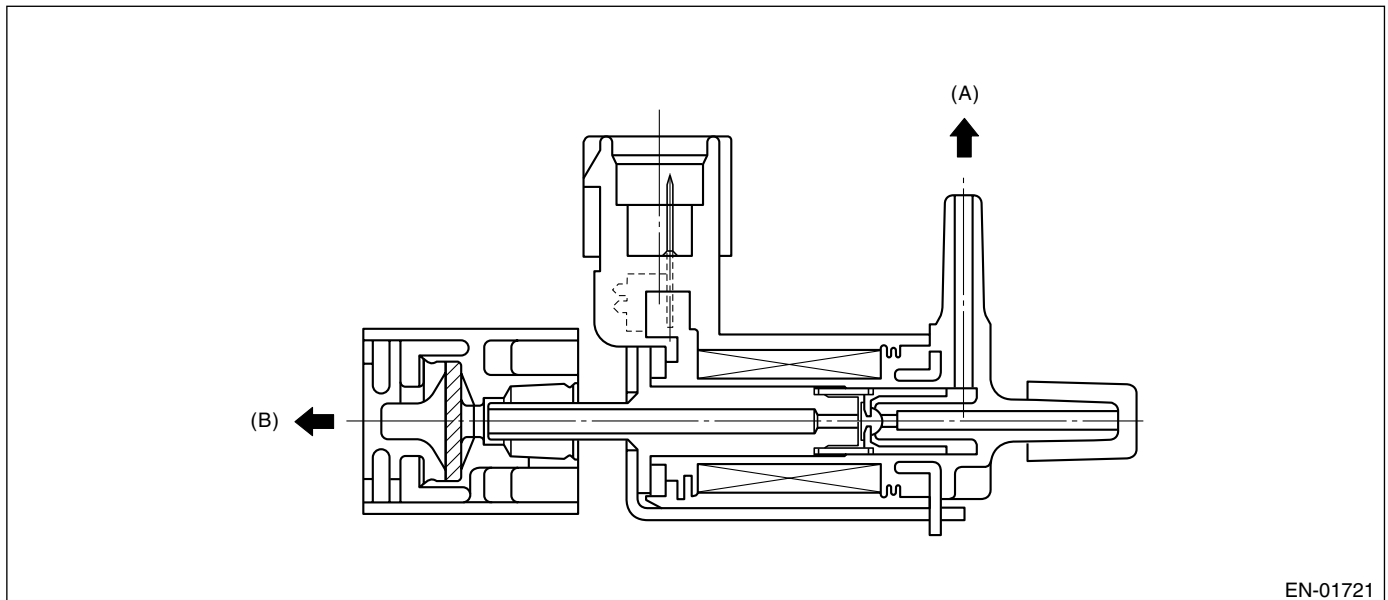

(A) Fuel tank pressure sensor

(B) External air

# DIAGNOSTIC TROUBLE CODE (DTC) DETECTING CRITERIA

## GENERAL DESCRIPTION

### 3. ENABLE CONDITION

Secondary Parameters	Enable Conditions
After engine starting	≥ 80 seconds
Fuel level	9.6 — 48 ℓ (2.54 — 12.68 US gal, 2.11 — 10.56 Imp gal)
Fuel tank pressure	< 0 or > 1.26 kPa (< 0 or > 9.45 mmHg, < 0 or > 0.372 inHg)

### 4. GENERAL DRIVING CYCLE

Perform the diagnosis continuously in 80 seconds after starting the engine. (Do not diagnose during evaporative emission control system diagnosis.)

### 5. DIAGNOSTIC METHOD

#### • Abnormality Judgment

Count the counter up when the malfunction criteria below are completed by checking the change such as tank pressure, atmospheric pressure and fuel level during every 80 seconds. Judge NG when the count comes to the specified number (3 times).

#### • Judgment Value

Malfunction Criteria	Threshold Value
Change of tank pressure during 80 seconds	≥ 0.6 kPa (4.5 mmHg, 0.2 inHg)
Change of atmospheric pressure during 80 seconds	≥ 0.6 kPa (4.5 mmHg, 0.2 inHg)
Change of fuel level during 80 seconds	< 8 ℓ (2.1 US gal, 1.8 Imp gal)

**Time Needed for Diagnosis:** 80 seconds × 3 times

**Malfunction Indicator Light Illumination:** Illuminates when malfunction occurs in 2 continuous driving cycles.

#### • Normality Judgment

Judge OK and clear the NG when all the malfunction criteria below are completed.

#### • Judgment Value

Malfunction Criteria	Threshold Value
Change of tank pressure during 80 seconds	≥ 0.6 kPa (4.5 mmHg, 0.2 inHg)
Change of atmospheric pressure during 80 seconds	< 0.6 kPa (4.5 mmHg, 0.2 inHg)

### 6. DTC CLEAR CONDITION

- When the OK idling cycle is completed 40 times in a row
- When "Clear Memory" was performed

### 7. MALFUNCTION INDICATOR LIGHT CLEAR CONDITION

- When the OK driving cycle is completed 3 times in a row
- When "Clear Memory" was performed

### 8. FAIL SAFE

None

### 9. ECM OPERATION AT DTC SETTING

Memorize the freeze frame data. (For test mode \$02)

**DIAGNOSTIC TROUBLE CODE (DTC) DETECTING CRITERIA**

GENERAL DESCRIPTION

---

**MEMO:**

# DIAGNOSTIC TROUBLE CODE (DTC) DETECTING CRITERIA

## GENERAL DESCRIPTION

### DB:DTC P1492 — EGR SOLENOID VALVE SIGNAL #1 CIRCUIT MALFUNCTION (LOW INPUT) —

#### 1. OUTLINE OF DIAGNOSIS

- Detect the open/short circuit of EGR.
- Judge NG when ECM output level is different from actual terminal level.

#### 2. COMPONENT DESCRIPTION

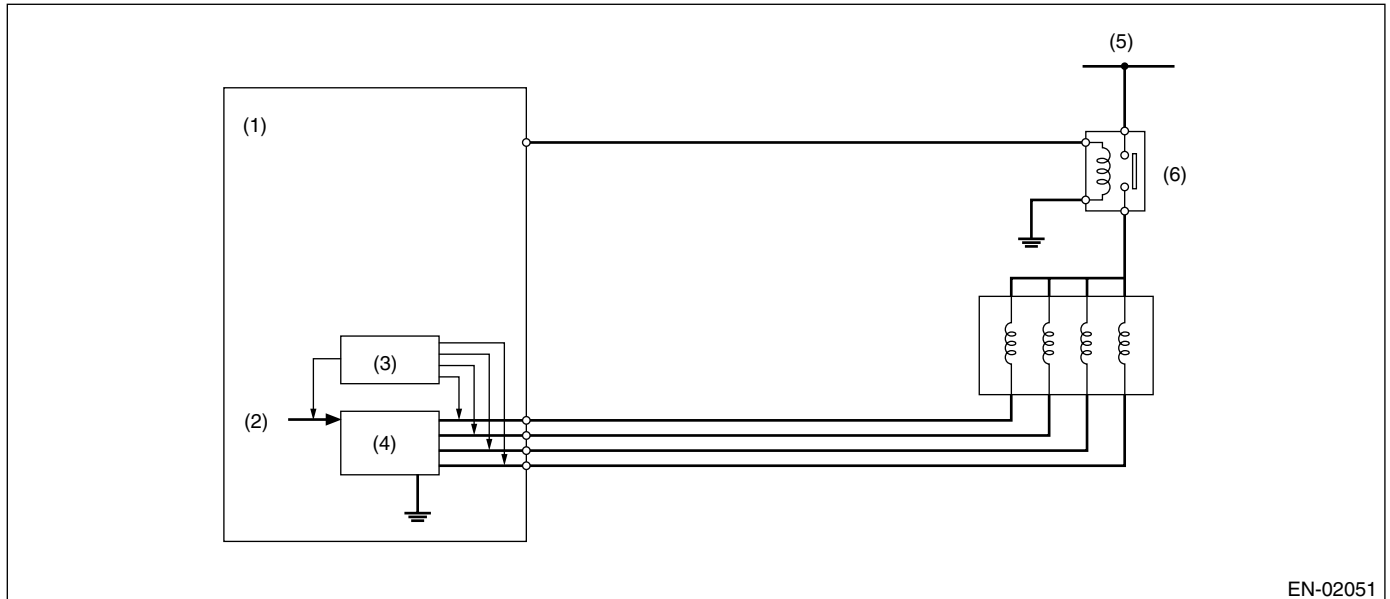

(1) Engine Control Module (ECM)

(3) Detecting circuit

(5) Battery voltage

(2) CPU

(4) Switching circuit

(6) Main relay

#### 3. ENABLE CONDITION

Secondary Parameters	Enable Conditions
Ignition switch	OFF
Battery voltage	> 10.9 V

#### 4. GENERAL DRIVING CYCLE

Always perform the diagnosis continuously.

# DIAGNOSTIC TROUBLE CODE (DTC) DETECTING CRITERIA

GENERAL DESCRIPTION

## 5. DIAGNOSTIC METHOD

### • Abnormality Judgment

Judge NG when the cumulative time until completing the malfunction criteria below becomes more than time needed for diagnosis.

### • Normality Judgment

Judge OK and clear the NG when the malfunction criteria below are not completed.

### • Judgment Value

Malfunction Criteria	Threshold Value	DTC
Terminal voltage level when ECM outputs OFF signal	Low level	P1492 P1494 P1496 P1498
Terminal voltage level when ECM outputs ON signal	High level	P1493 P1495 P1497 P1499

**Time Needed for Diagnosis:** 2.5 seconds

**Malfunction Indicator Light Illumination:** Illuminates as soon as malfunction occurs.

## 6. DTC CLEAR CONDITION

- When the OK idling cycle was completed 40 times in a row
- When "Clear Memory" was performed

## 7. MALFUNCTION INDICATOR LIGHT CLEAR CONDITION

- When the OK driving cycle was completed 3 times in a row
- When "Clear Memory" was performed

## 8. FAIL SAFE

None

## 9. ECM OPERATION AT DTC SETTING

Memorize the freeze frame data. (For test mode \$02)

# DIAGNOSTIC TROUBLE CODE (DTC) DETECTING CRITERIA

## GENERAL DESCRIPTION

### DC:DTC P1493 — EGR SOLENOID VALVE SIGNAL #1 CIRCUIT MALFUNCTION (HIGH INPUT) —

#### 1. OUTLINE OF DIAGNOSIS

- Detect the open/short circuit of EGR.
- Judge NG when ECM output level is different from actual terminal level.

#### 2. COMPONENT DESCRIPTION

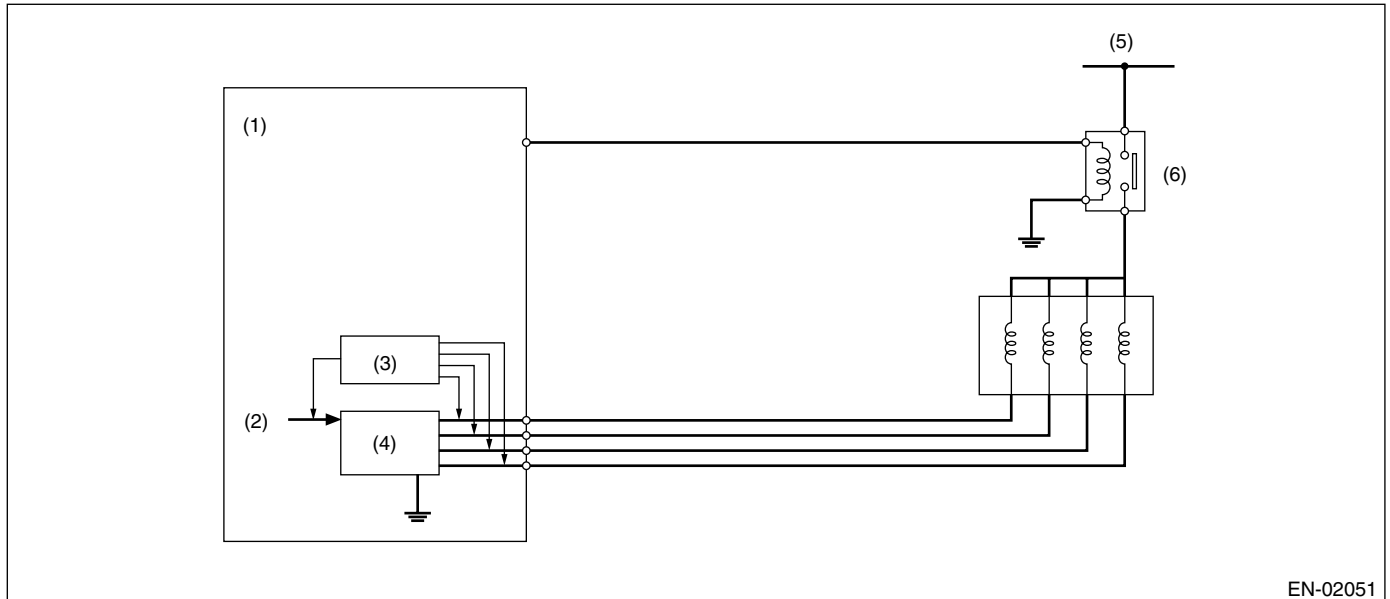

EN-02051

(1) Engine Control Module (ECM)

(3) Detecting circuit

(5) Battery voltage

(2) CPU

(4) Switching circuit

(6) Main relay

#### 3. ENABLE CONDITION

Secondary Parameters	Enable Conditions
Ignition switch	OFF
Battery voltage	> 10.9 V

#### 4. GENERAL DRIVING CYCLE

Always perform the diagnosis continuously.



# DIAGNOSTIC TROUBLE CODE (DTC) DETECTING CRITERIA

GENERAL DESCRIPTION

## 5. DIAGNOSTIC METHOD

### • Abnormality Judgment

Judge NG when the cumulative time until completing the malfunction criteria below becomes more than time needed for diagnosis.

### • Normality Judgment

Judge OK and clear the NG when the malfunction criteria below are not completed.

### • Judgment Value

Malfunction Criteria	Threshold Value	DTC
Terminal voltage level when ECM outputs OFF signal	Low level	P1492 P1494 P1496 P1498
Terminal voltage level when ECM outputs ON signal	High level	P1493 P1495 P1497 P1499

**Time Needed for Diagnosis:** 2.5 seconds

**Malfunction Indicator Light Illumination:** Illuminates as soon as malfunction occurs.

## 6. DTC CLEAR CONDITION

- When the OK idling cycle is completed 40 times in a row
- When "Clear Memory" was performed

## 7. MALFUNCTION INDICATOR LIGHT CLEAR CONDITION

- When the OK driving cycle was completed 3 times in a row
- When "Clear Memory" was performed

## 8. FAIL SAFE

None

## 9. ECM OPERATION AT DTC SETTING

Memorize the freeze frame data. (For test mode \$02)

# DIAGNOSTIC TROUBLE CODE (DTC) DETECTING CRITERIA

## GENERAL DESCRIPTION

### DD:DTC P1494 — EGR SOLENOID VALVE SIGNAL #2 CIRCUIT MALFUNCTION (LOW INPUT) —

#### 1. OUTLINE OF DIAGNOSIS

- Detect the open/short circuit of EGR.
- Judge NG when ECM output level is different from actual terminal level.

#### 2. COMPONENT DESCRIPTION

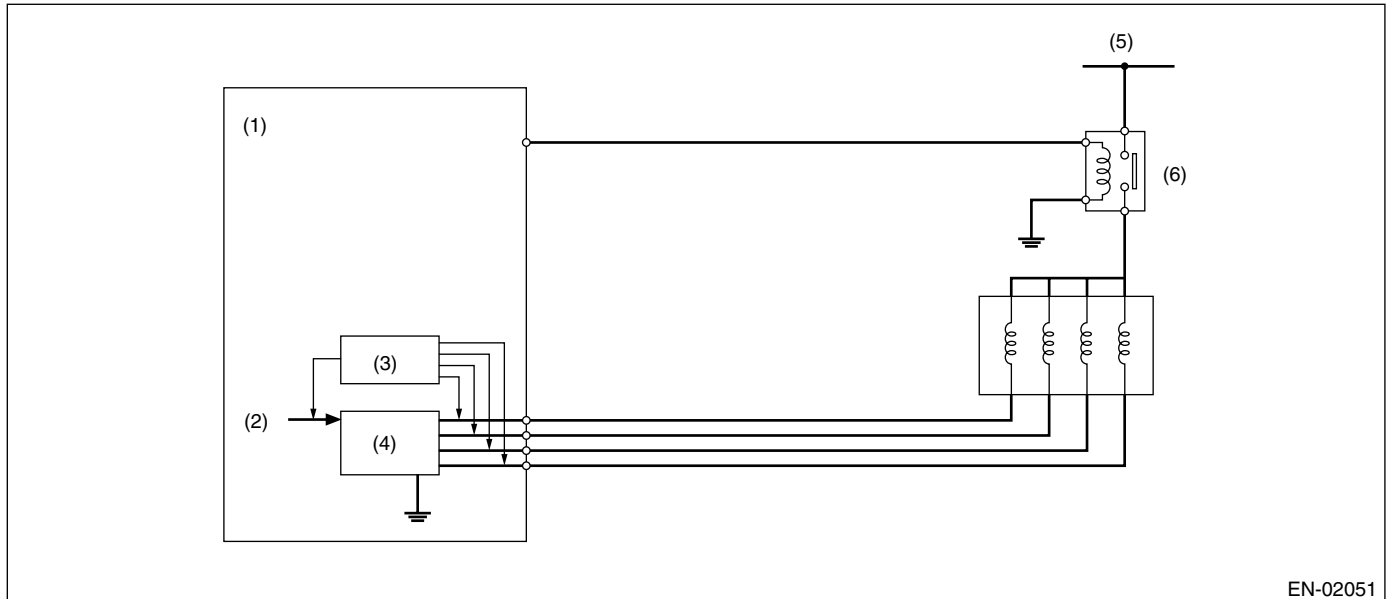

(1) Engine Control Module (ECM)

(3) Detecting circuit

(5) Battery voltage

(2) CPU

(4) Switching circuit

(6) Main relay

#### 3. ENABLE CONDITION

Secondary Parameters	Enable Conditions
Ignition switch	OFF
Battery voltage	> 10.9 V

#### 4. GENERAL DRIVING CYCLE

Always perform the diagnosis continuously.

# DIAGNOSTIC TROUBLE CODE (DTC) DETECTING CRITERIA

GENERAL DESCRIPTION

## 5. DIAGNOSTIC METHOD

### • Abnormality Judgment

Judge NG when the cumulative time until completing the malfunction criteria below becomes more than time needed for diagnosis.

### • Normality Judgment

Judge OK and clear the NG when the malfunction criteria below are not completed.

### • Judgment Value

Malfunction Criteria	Threshold Value	DTC
Terminal voltage level when ECM outputs OFF signal	Low level	P1292 P1294 P1296 P1298
Terminal voltage level when ECM outputs ON signal	High level	P1293 P1295 P1297 P1299

**Time Needed for Diagnosis:** 2.5 seconds

**Malfunction Indicator Light Illumination:** Illuminates as soon as malfunction occurs.

## 6. DTC CLEAR CONDITION

- When the OK idling cycle is completed 40 times in a row
- When "Clear Memory" was performed

## 7. MALFUNCTION INDICATOR LIGHT CLEAR CONDITION

- When the OK driving cycle was completed 3 times in a row
- When "Clear Memory" was performed

## 8. FAIL SAFE

None

## 9. ECM OPERATION AT DTC SETTING

Memorize the freeze frame data. (For test mode \$02)

# DIAGNOSTIC TROUBLE CODE (DTC) DETECTING CRITERIA

## GENERAL DESCRIPTION

### DE:DTC P1495 — EGR SOLENOID VALVE SIGNAL #2 CIRCUIT MALFUNCTION (HIGH INPUT) —

#### 1. OUTLINE OF DIAGNOSIS

- Detect the open/short circuit of EGR.
- Judge NG when ECM output level is different from actual terminal level.

#### 2. COMPONENT DESCRIPTION

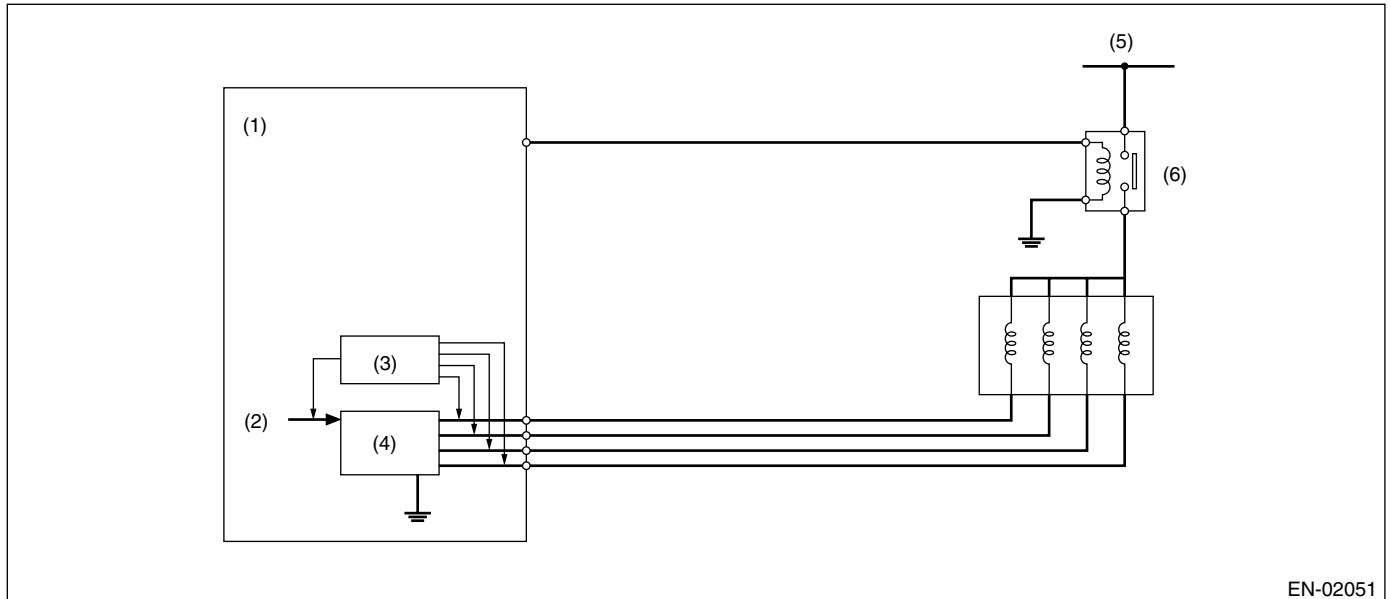

(1) Engine Control Module (ECM)

(3) Detecting circuit

(5) Battery voltage

(2) CPU

(4) Switching circuit

(6) Main relay

#### 3. ENABLE CONDITION

Secondary Parameters	Enable Conditions
Ignition switch	OFF
Battery voltage	> 10.9 V

#### 4. GENERAL DRIVING CYCLE

Always perform the diagnosis continuously.

# DIAGNOSTIC TROUBLE CODE (DTC) DETECTING CRITERIA

GENERAL DESCRIPTION

## 5. DIAGNOSTIC METHOD

### • Abnormality Judgment

Judge NG when the cumulative time until completing the malfunction criteria below becomes more than time needed for diagnosis.

### • Normality Judgment

Judge OK and clear the NG when the malfunction criteria below are not completed.

### • Judgment Value

Malfunction Criteria	Threshold Value	DTC
Terminal voltage level when ECM outputs OFF signal	Low level	P1292 P1294 P1296 P1298
Terminal voltage level when ECM outputs ON signal	High level	P1293 P1295 P1297 P1299

**Time Needed for Diagnosis:** 2.5 seconds

**Malfunction Indicator Light Illumination:** Illuminates as soon as malfunction occurs.

## 6. DTC CLEAR CONDITION

- When the OK idling cycle is completed 40 times in a row
- When "Clear Memory" was performed

## 7. MALFUNCTION INDICATOR LIGHT CLEAR CONDITION

- When the OK driving cycle was completed 3 times in a row
- When "Clear Memory" was performed

## 8. FAIL SAFE

None

## 9. ECM OPERATION AT DTC SETTING

Memorize the freeze frame data. (For test mode \$02)

# DIAGNOSTIC TROUBLE CODE (DTC) DETECTING CRITERIA

## GENERAL DESCRIPTION

### DF:DTC P1496 — EGR SOLENOID VALVE SIGNAL #3 CIRCUIT MALFUNCTION (LOW INPUT) —

#### 1. OUTLINE OF DIAGNOSIS

- Detect the open/short circuit of EGR.
- Judge NG when ECM output level is different from actual terminal level.

#### 2. COMPONENT DESCRIPTION

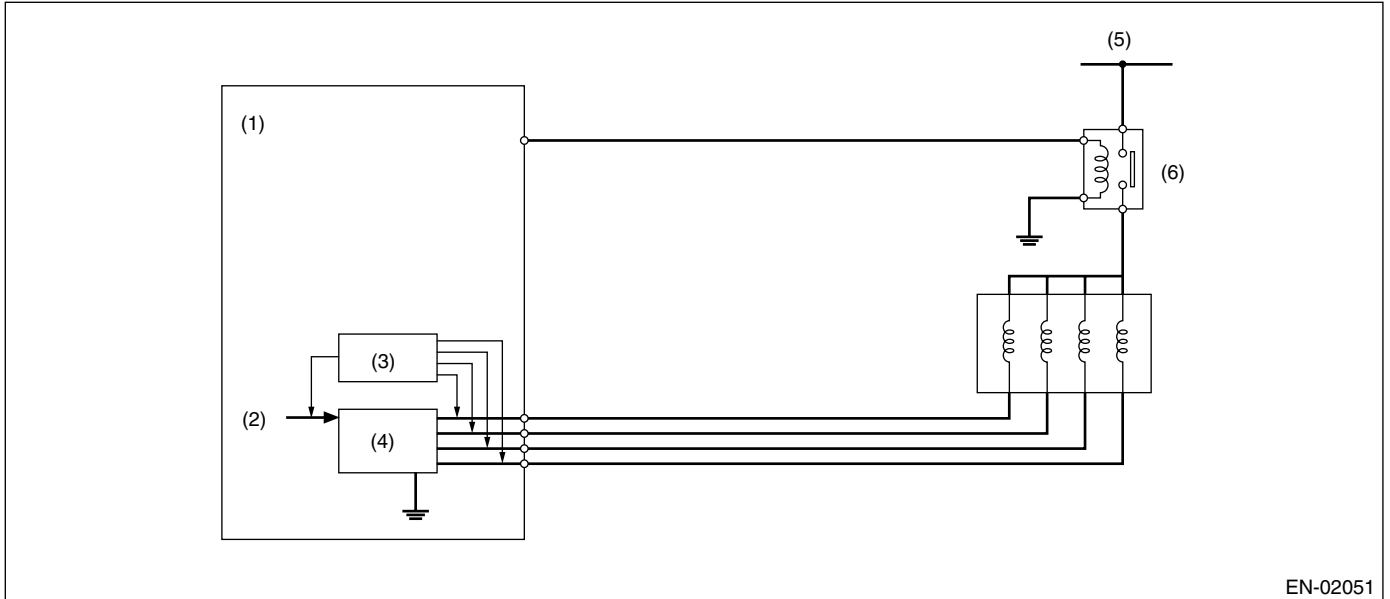

EN-02051

(1) Engine Control Module (ECM)

(3) Detecting circuit

(5) Battery voltage

(2) CPU

(4) Switching circuit

(6) Main relay

#### 3. ENABLE CONDITION

Secondary Parameters	Enable Conditions
Ignition switch	OFF
Battery voltage	> 10.9 V

#### 4. GENERAL DRIVING CYCLE

Always perform the diagnosis continuously.

# DIAGNOSTIC TROUBLE CODE (DTC) DETECTING CRITERIA

GENERAL DESCRIPTION

## 5. DIAGNOSTIC METHOD

### • Abnormality Judgment

Judge NG when the cumulative time until completing the malfunction criteria below becomes more than time needed for diagnosis.

### • Normality Judgment

Judge OK and clear the NG when the malfunction criteria below are not completed.

### • Judgment Value

Malfunction Criteria	Threshold Value	DTC
Terminal voltage level when ECM outputs OFF signal	Low level	P1292 P1294 P1296 P1298
Terminal voltage level when ECM outputs ON signal	High level	P1293 P1295 P1297 P1299

**Time Needed for Diagnosis:** 2.5 seconds

**Malfunction Indicator Light Illumination:** Illuminates as soon as malfunction occurs.

## 6. DTC CLEAR CONDITION

- When the OK idling cycle is completed 40 times in a row
- When "Clear Memory" was performed

## 7. MALFUNCTION INDICATOR LIGHT CLEAR CONDITION

- When the OK driving cycle was completed 3 times in a row
- When "Clear Memory" was performed

## 8. FAIL SAFE

None

## 9. ECM OPERATION AT DTC SETTING

Memorize the freeze frame data. (For test mode \$02)

# DIAGNOSTIC TROUBLE CODE (DTC) DETECTING CRITERIA

## GENERAL DESCRIPTION

### DG:DTC P1497 — EGR SOLENOID VALVE SIGNAL #3 CIRCUIT MALFUNCTION (HIGH INPUT) —

#### 1. OUTLINE OF DIAGNOSIS

- Detect the open/short circuit of EGR.
- Judge NG when ECM output level is different from actual terminal level.

#### 2. COMPONENT DESCRIPTION

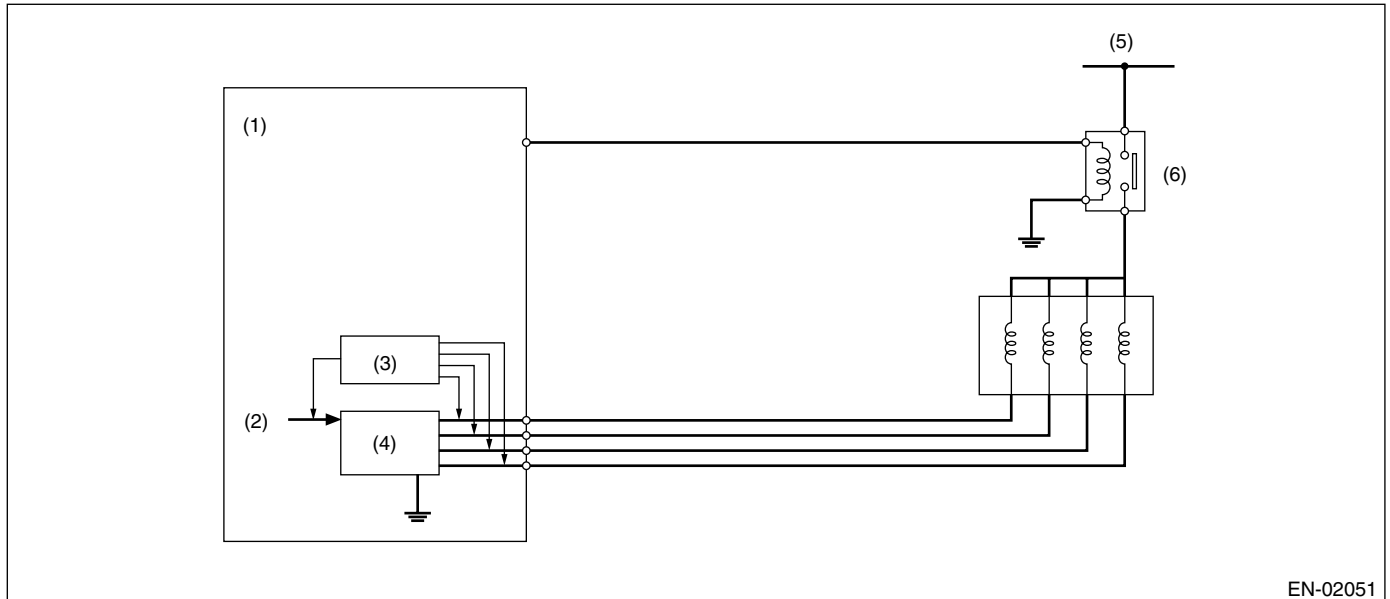

EN-02051

(1) Engine Control Module (ECM)

(3) Detecting circuit

(5) Battery voltage

(2) CPU

(4) Switching circuit

(6) Main relay

#### 3. ENABLE CONDITION

Secondary Parameters	Enable Conditions
Ignition switch	OFF
Battery voltage	> 10.9 V

#### 4. GENERAL DRIVING CYCLE

Always perform the diagnosis continuously.



# DIAGNOSTIC TROUBLE CODE (DTC) DETECTING CRITERIA

GENERAL DESCRIPTION

## 5. DIAGNOSTIC METHOD

### • Abnormality Judgment

Judge NG when the cumulative time until completing the malfunction criteria below becomes more than time needed for diagnosis.

### • Normality Judgment

Judge OK and clear the NG when the malfunction criteria below are not completed.

### • Judgment Value

Malfunction Criteria	Threshold Value	DTC
Terminal voltage level when ECM outputs OFF signal	Low level	P1292 P1294 P1296 P1298
Terminal voltage level when ECM outputs ON signal	High level	P1293 P1295 P1297 P1299

**Time Needed for Diagnosis:** 2.5 seconds

**Malfunction Indicator Light Illumination:** Illuminates as soon as malfunction occurs.

## 6. DTC CLEAR CONDITION

- When the OK idling cycle is completed 40 times in a row
- When "Clear Memory" was performed

## 7. MALFUNCTION INDICATOR LIGHT CLEAR CONDITION

- When the OK driving cycle was completed 3 times in a row
- When "Clear Memory" was performed

## 8. FAIL SAFE

None

## 9. ECM OPERATION AT DTC SETTING

Memorize the freeze frame data. (For test mode \$02)

# DIAGNOSTIC TROUBLE CODE (DTC) DETECTING CRITERIA

## GENERAL DESCRIPTION

### DH:DTC P1498 — EGR SOLENOID VALVE SIGNAL #4 CIRCUIT MALFUNCTION (LOW INPUT) —

#### 1. OUTLINE OF DIAGNOSIS

- Detect the open/short circuit of EGR.
- Judge NG when ECM output level is different from actual terminal level.

#### 2. COMPONENT DESCRIPTION

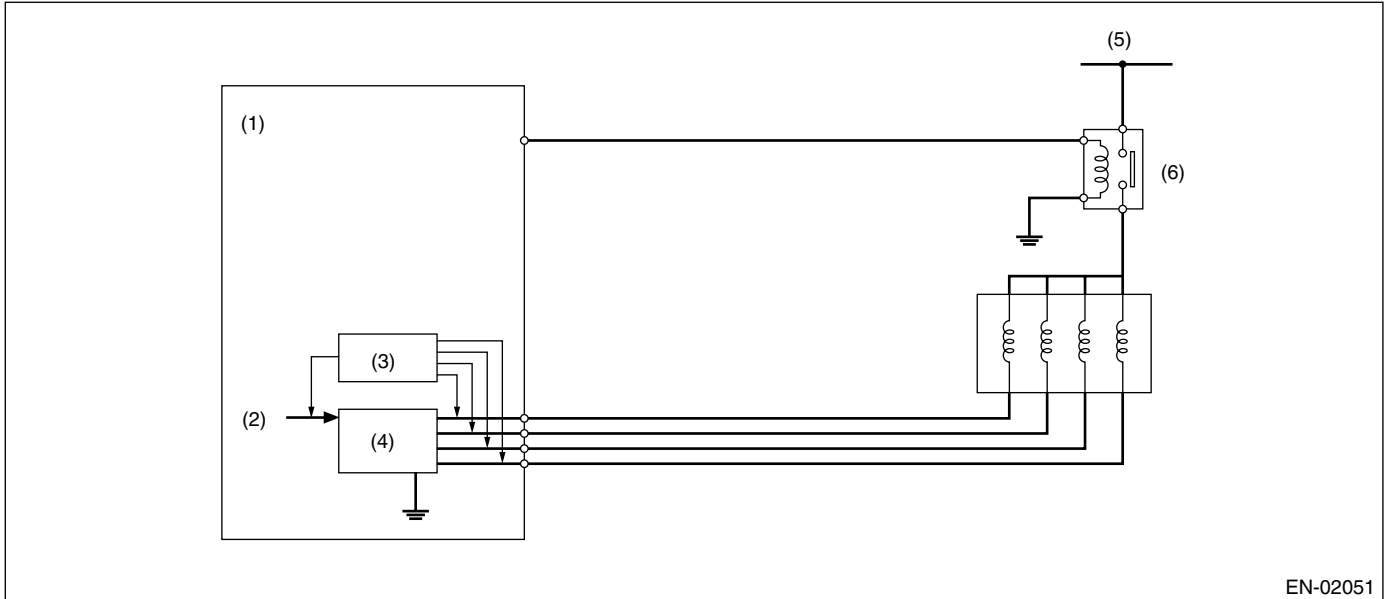

(1) Engine Control Module (ECM)

(3) Detecting circuit

(5) Battery voltage

(2) CPU

(4) Switching circuit

(6) Main relay

#### 3. ENABLE CONDITION

Secondary Parameters	Enable Conditions
Ignition switch	OFF
Battery voltage	> 10.9 V

#### 4. GENERAL DRIVING CYCLE

Always perform the diagnosis continuously.

# DIAGNOSTIC TROUBLE CODE (DTC) DETECTING CRITERIA

GENERAL DESCRIPTION

## 5. DIAGNOSTIC METHOD

### • Abnormality Judgment

Judge NG when the cumulative time until completing the malfunction criteria below becomes more than time needed for diagnosis.

### • Normality Judgment

Judge OK and clear the NG when the malfunction criteria below are not completed.

### • Judgment Value

Malfunction Criteria	Threshold Value	DTC
Terminal voltage level when ECM outputs OFF signal	Low level	P1292 P1294 P1296 P1298
Terminal voltage level when ECM outputs ON signal	High level	P1293 P1295 P1297 P1299

**Time Needed for Diagnosis:** 2.5 seconds

**Malfunction Indicator Light Illumination:** Illuminates as soon as malfunction occurs.

## 6. DTC CLEAR CONDITION

- When the OK idling cycle is completed 40 times in a row
- When "Clear Memory" was performed

## 7. MALFUNCTION INDICATOR LIGHT CLEAR CONDITION

- When the OK driving cycle was completed 3 times in a row
- When "Clear Memory" was performed

## 8. FAIL SAFE

None

## 9. ECM OPERATION AT DTC SETTING

Memorize the freeze frame data. (For test mode \$02)

# DIAGNOSTIC TROUBLE CODE (DTC) DETECTING CRITERIA

## GENERAL DESCRIPTION

### DI: DTC P1499 — EGR SOLENOID VALVE SIGNAL #4 CIRCUIT MALFUNCTION (HIGH INPUT) —

#### 1. OUTLINE OF DIAGNOSIS

- Detect the open/short circuit of EGR.
- Judge NG when ECM output level is different from actual terminal level.

#### 2. COMPONENT DESCRIPTION

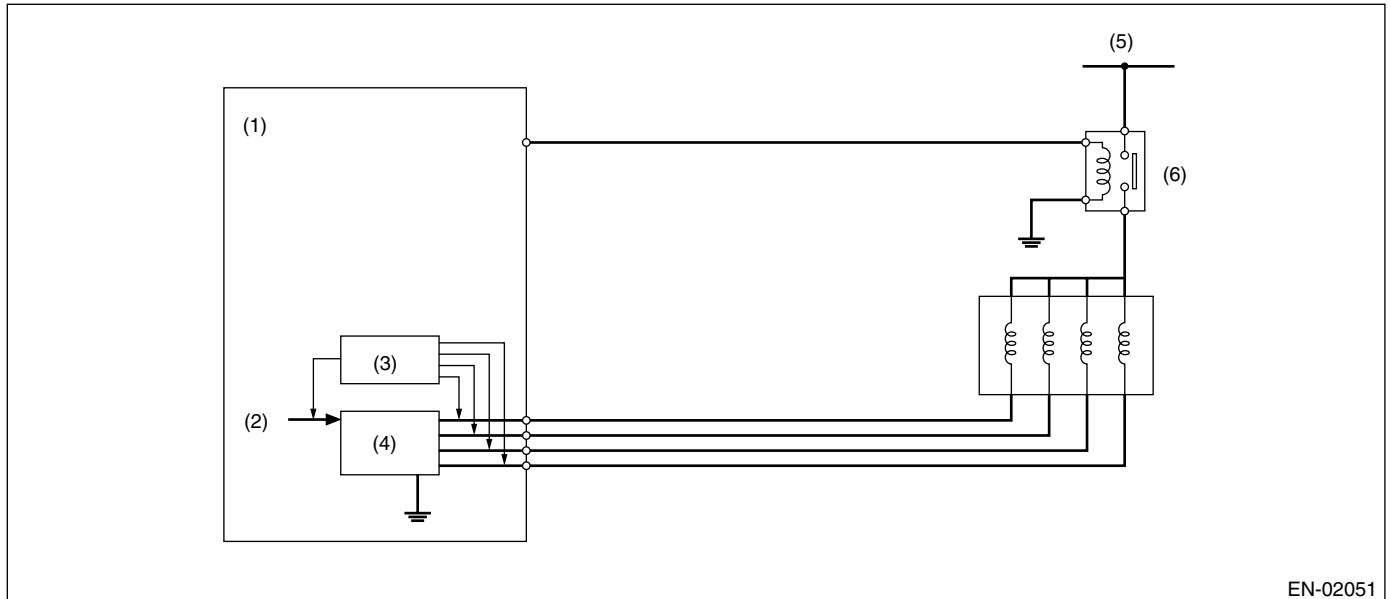

EN-02051

(1) Engine Control Module (ECM)

(3) Detecting circuit

(5) Battery voltage

(2) CPU

(4) Switching circuit

(6) Main relay

#### 3. ENABLE CONDITION

Secondary Parameters	Enable Conditions
Ignition switch	OFF
Battery voltage	> 10.9 V

#### 4. GENERAL DRIVING CYCLE

Always perform the diagnosis continuously.

# DIAGNOSTIC TROUBLE CODE (DTC) DETECTING CRITERIA

GENERAL DESCRIPTION

## 5. DIAGNOSTIC METHOD

### • Abnormality Judgment

Judge NG when the cumulative time until completing the malfunction criteria below becomes more than time needed for diagnosis.

### • Normality Judgment

Judge OK and clear the NG when the malfunction criteria below are not completed.

### • Judgment Value

Malfunction Criteria	Threshold Value	DTC
Terminal voltage level when ECM outputs OFF signal	Low level	P1292 P1294 P1296 P1298
Terminal voltage level when ECM outputs ON signal	High level	P1293 P1295 P1297 P1299

**Time Needed for Diagnosis:** 2.5 seconds

**Malfunction Indicator Light Illumination:** Illuminates as soon as malfunction occurs.

## 6. DTC CLEAR CONDITION

- When the OK idling cycle is completed 40 times in a row
- When "Clear Memory" was performed

## 7. MALFUNCTION INDICATOR LIGHT CLEAR CONDITION

- When the OK driving cycle was completed 3 times in a row
- When "Clear Memory" was performed

## 8. FAIL SAFE

None

## 9. ECM OPERATION AT DTC SETTING

Memorize the freeze frame data. (For test mode \$02)

# DIAGNOSTIC TROUBLE CODE (DTC) DETECTING CRITERIA

## GENERAL DESCRIPTION

### DJ:DTC P1510 — ISC SOLENOID VALVE SIGNAL #1 CIRCUIT MALFUNCTION (LOW INPUT) —

#### 1. OUTLINE OF DIAGNOSIS

- Detect the open/short circuit of idle air control solenoid valve.
- Judge NG when the output terminal is Low level even though ECM outputs OFF signal.

#### 2. COMPONENT DESCRIPTION

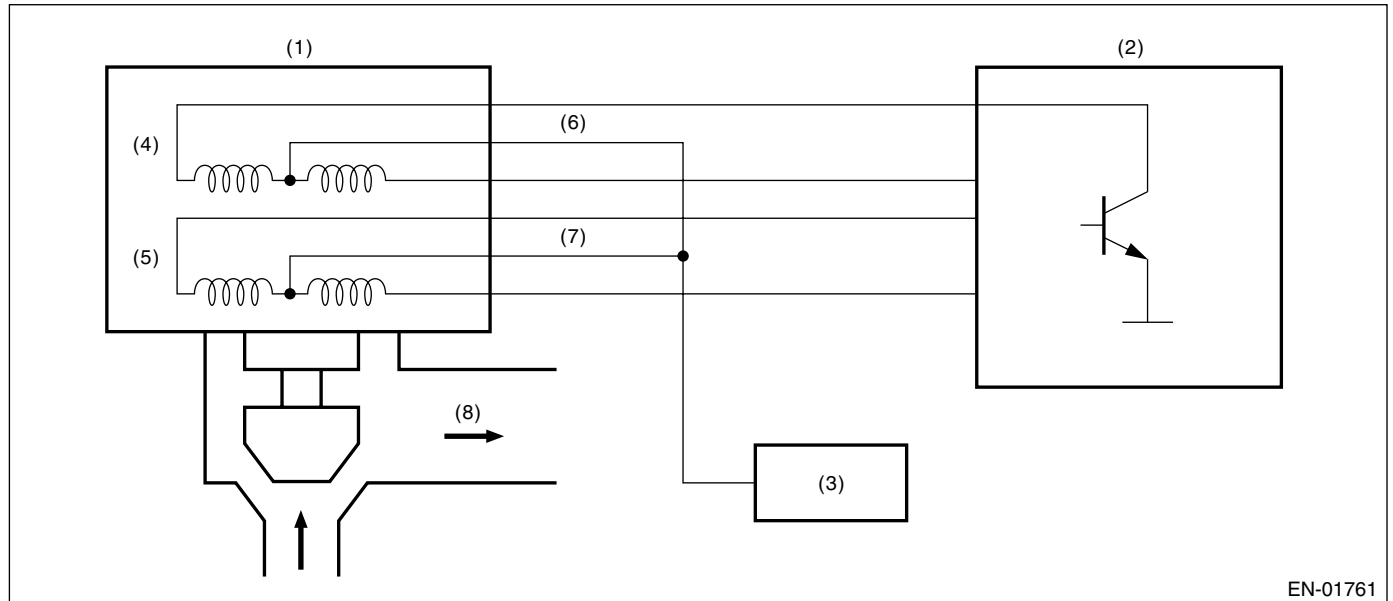

- (1) Idle air control solenoid valve
- (2) Engine control module (ECM)
- (3) Ignition relay
- (4) A phase
- (5) B phase
- (6) A phase power
- (7) B phase power
- (8) Intake air

#### 3. ENABLE CONDITION

Secondary Parameters	Enable Conditions
Ignition switch	OFF
Battery voltage	> 10.9 V

#### 4. GENERAL DRIVING CYCLE

Perform the diagnosis when starter switch is OFF.

# DIAGNOSTIC TROUBLE CODE (DTC) DETECTING CRITERIA

GENERAL DESCRIPTION

## 5. DIAGNOSTIC METHOD

### • Abnormality Judgment

Judge NG when the cumulative time until completing the malfunction criteria below becomes more than time needed for diagnosis.

### • Judgment Value

Malfunction Criteria	Threshold Value
Terminal voltage level when ECM outputs OFF signal	Low level

**Time Needed for Diagnosis:** 0.5 seconds

**Malfunction Indicator Light Illumination:** Illuminates as soon as malfunction occurs.

### • Normality Judgment

Judge OK and clear the NG when the malfunction criteria below are completed.

### • Judgment Value

Malfunction Criteria	Threshold Value
Terminal voltage level when ECM outputs OFF signal	High level

## 6. DTC CLEAR CONDITION

- When the OK idling cycle is completed 40 times in a row
- When "Clear Memory" was performed

## 7. MALFUNCTION INDICATOR LIGHT CLEAR CONDITION

- When the OK driving cycle was completed 3 times in a row
- When "Clear Memory" was performed

## 8. FAIL SAFE

- Cut the fuel of all cylinders, #1 cylinder or #1, #2 cylinder according to throttle position, engine speed, vehicle speed.
- ISC closed loop compensation value becomes zero. [ISCCL = 0 (l/min)]

## 9. ECM OPERATION AT DTC SETTING

Memorize the freeze frame data. (For test mode \$02)

# DIAGNOSTIC TROUBLE CODE (DTC) DETECTING CRITERIA

## GENERAL DESCRIPTION

### DK:DTC P1511 — ISC SOLENOID VALVE SIGNAL #1 CIRCUIT MALFUNCTION (HIGH INPUT) —

#### 1. OUTLINE OF DIAGNOSIS

- Detect the open/short circuit of idle air control solenoid valve.
- Judge NG when the output terminal is High level even though ECM outputs ON signal.

#### 2. COMPONENT DESCRIPTION

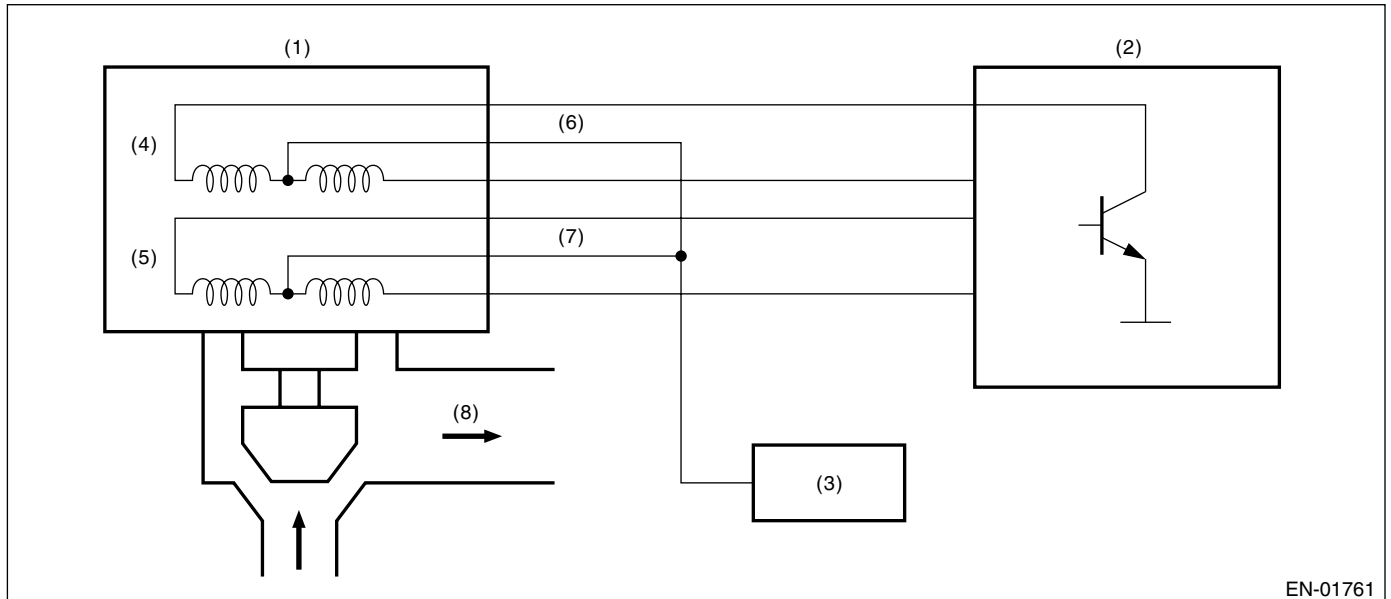

- |                                     |                   |                   |
|-------------------------------------|-------------------|-------------------|
| (1) Idle air control solenoid valve | (4) A phase       | (7) B phase power |
| (2) Engine control module (ECM)     | (5) B phase       | (8) Intake air    |
| (3) Ignition relay                  | (6) A phase power |                   |

#### 3. ENABLE CONDITION

Secondary Parameters	Enable Conditions
Starter switch	OFF
Battery voltage	> 10.9 V

#### 4. GENERAL DRIVING CYCLE

Perform the diagnosis continuously when starter switch is OFF.



# DIAGNOSTIC TROUBLE CODE (DTC) DETECTING CRITERIA

GENERAL DESCRIPTION

## 5. DIAGNOSTIC METHOD

### • Abnormality Judgment

Judge NG when the cumulative time until completing the malfunction criteria below becomes more than time needed for diagnosis.

### • Judgment Value

Malfunction Criteria	Threshold Value
Terminal voltage level when ECM outputs ON signal	High level

**Time needed for diagnosis:** 0.5 seconds

**Malfunction Indicator Light Illumination:** Illuminates as soon as malfunction occurs.

### • Normality Judgment

Judge OK and clear the NG when the malfunction criteria below are completed.

### • Judgment Value

Malfunction Criteria	Threshold Value
Terminal voltage level when ECM outputs ON signal	Low level

## 6. DTC CLEAR CONDITION

- When the OK idling cycle is completed 40 times in a row
- When "Clear Memory" was performed

## 7. MALFUNCTION INDICATOR LIGHT CLEAR CONDITION

- When the OK driving cycle was completed 3 times in a row
- When "Clear Memory" was performed

## 8. FAIL SAFE

- Cut the fuel of all cylinders, #1 cylinder or #1, #2 cylinder according to throttle position, engine speed, vehicle speed.
- ISC closed loop compensation value becomes zero. [ISCCL = 0 (l/min)]

## 9. ECM OPERATION AT DTC SETTING

Memorize the freeze frame data. (For test mode \$02)

# DIAGNOSTIC TROUBLE CODE (DTC) DETECTING CRITERIA

## GENERAL DESCRIPTION

### DL:DTC P1512 — ISC SOLENOID VALVE SIGNAL #2 CIRCUIT MALFUNCTION (LOW INPUT) —

#### 1. OUTLINE OF DIAGNOSIS

- Detect the open/short circuit of idle air control solenoid valve.
- Judge NG when the output terminal is Low level even though ECM outputs OFF signal.

#### 2. COMPONENT DESCRIPTION

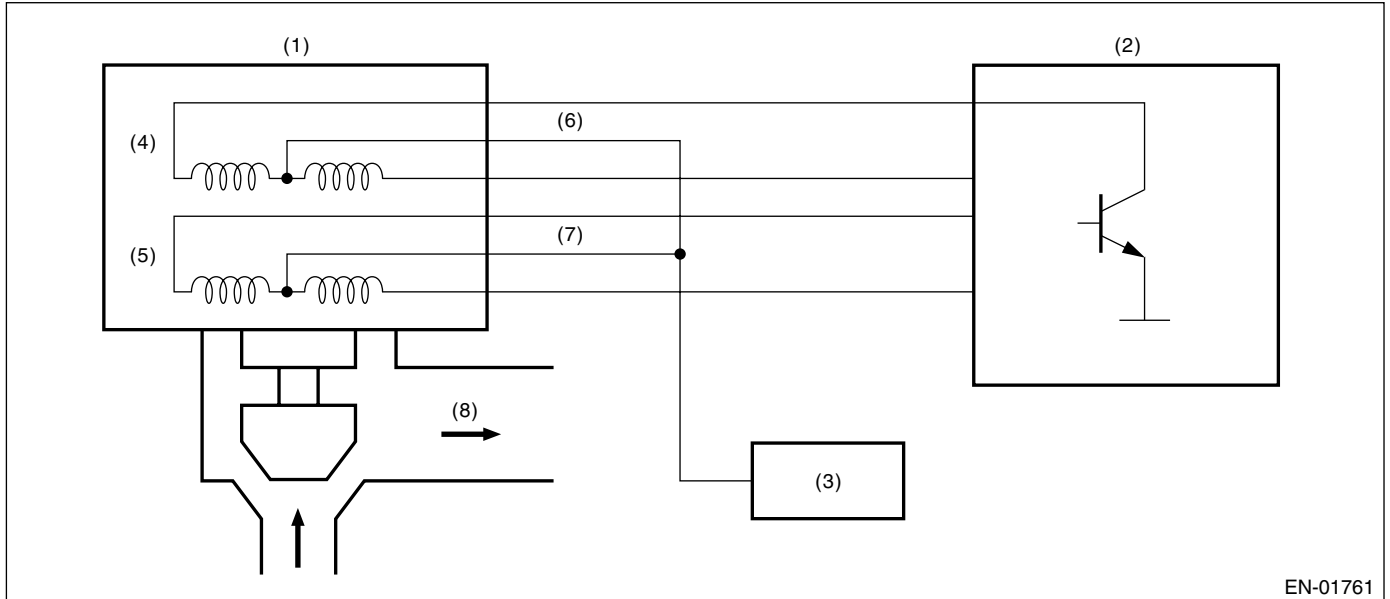

EN-01761

- |                                     |                   |                   |
|-------------------------------------|-------------------|-------------------|
| (1) Idle air control solenoid valve | (4) A phase       | (7) B phase power |
| (2) Engine control module (ECM)     | (5) B phase       | (8) Intake air    |
| (3) Ignition relay                  | (6) A phase power |                   |

#### 3. ENABLE CONDITION

Secondary Parameters	Enable Conditions
Starter switch	OFF
Battery voltage	> 10.9 V

#### 4. GENERAL DRIVING CYCLE

Perform the diagnosis continuously when starter switch is OFF.

# DIAGNOSTIC TROUBLE CODE (DTC) DETECTING CRITERIA

GENERAL DESCRIPTION

## 5. DIAGNOSTIC METHOD

### • Abnormality Judgment

Judge NG when the cumulative time until completing the malfunction criteria below becomes more than time needed for diagnosis.

### • Judgment Value

Malfunction Criteria	Threshold Value
Terminal voltage level when ECM outputs OFF signal	Low level

**Time Needed for Diagnosis:** 0.5 seconds

**Malfunction Indicator Light Illumination:** Illuminates as soon as malfunction occurs.

### • Normality Judgment

Judge OK and clear the NG when the malfunction criteria below are completed.

### • Judgment Value

Malfunction Criteria	Threshold Value
Terminal voltage level when ECM outputs OFF signal	High level

## 6. DTC CLEAR CONDITION

- When the OK idling cycle is completed 40 times in a row
- When "Clear Memory" was performed

## 7. MALFUNCTION INDICATOR LIGHT CLEAR CONDITION

- When the OK driving cycle was completed 3 times in a row
- When "Clear Memory" was performed

## 8. FAIL SAFE

- Cut the fuel of all cylinders, #1 cylinder or #1, #2 cylinder according to throttle position, engine speed, vehicle speed.
- ISC closed loop compensation value becomes zero. [ISCCL = 0 (l/min)]

## 9. ECM OPERATION AT DTC SETTING

Memorize the freeze frame data. (For test mode \$02)

# DIAGNOSTIC TROUBLE CODE (DTC) DETECTING CRITERIA

## GENERAL DESCRIPTION

### DM:DTC P1513 — ISC SOLENOID VALVE SIGNAL #2 CIRCUIT MALFUNCTION (HIGH INPUT) —

#### 1. OUTLINE OF DIAGNOSIS

- Detect the open/short circuit of idle air control solenoid valve.
- Judge NG when the output terminal is High level even though ECM outputs ON signal.

#### 2. COMPONENT DESCRIPTION

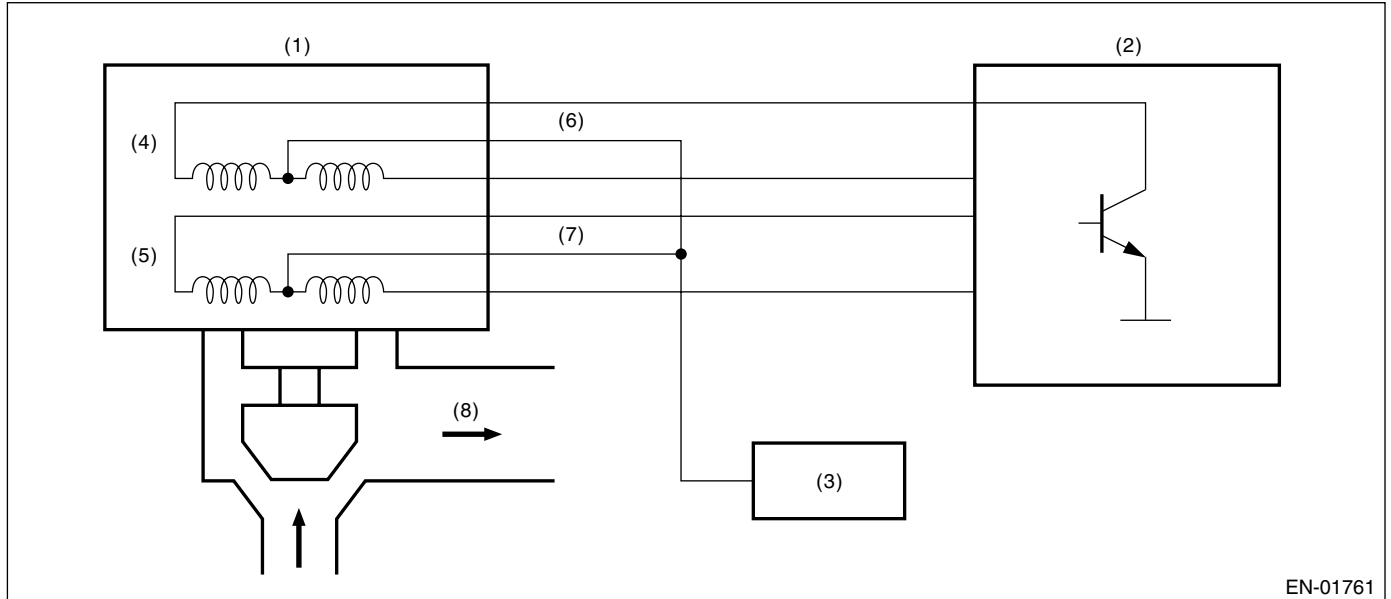

- (1) Idle air control solenoid valve
- (2) Engine control module (ECM)
- (3) Ignition relay
- (4) A phase
- (5) B phase
- (6) A phase power
- (7) B phase power
- (8) Intake air

#### 3. ENABLE CONDITION

Secondary Parameters	Enable Conditions
Starter switch	OFF
Battery voltage	> 10.9 V

#### 4. GENERAL DRIVING CYCLE

Perform the diagnosis continuously when starter switch is OFF.

# DIAGNOSTIC TROUBLE CODE (DTC) DETECTING CRITERIA

GENERAL DESCRIPTION

## 5. DIAGNOSTIC METHOD

### • Abnormality Judgment

Judge NG when the cumulative time until completing the malfunction criteria below becomes more than time needed for diagnosis.

### • Judgment Value

Malfunction Criteria	Threshold Value
Terminal voltage level when ECM outputs ON signal	High level

**Time Needed for Diagnosis:** 0.5 seconds

**Malfunction Indicator Light Illumination:** Illuminates as soon as malfunction occurs.

### • Normality Judgment

Judge OK and clear the NG when the malfunction criteria below are completed.

### • Judgment Value

Malfunction Criteria	Threshold Value
Terminal voltage level when ECM outputs ON signal	Low level

## 6. DTC CLEAR CONDITION

- When the OK idling cycle is completed 40 times in a row
- When "Clear Memory" was performed

## 7. MALFUNCTION INDICATOR LIGHT CLEAR CONDITION

- When the OK driving cycle was completed 3 times in a row
- When "Clear Memory" was performed

## 8. FAIL SAFE

- Cut the fuel of all cylinders, #1 cylinder or #1, #2 cylinder according to throttle position, engine speed, vehicle speed.
- ISC closed loop compensation value becomes zero. [ISCCL = 0 (l/min)]

## 9. ECM OPERATION AT DTC SETTING

Memorize the freeze frame data. (For test mode \$02)

# DIAGNOSTIC TROUBLE CODE (DTC) DETECTING CRITERIA

## GENERAL DESCRIPTION

### DN:DTC P1514 — ISC SOLENOID VALVE SIGNAL #3 CIRCUIT MALFUNCTION (LOW INPUT) —

#### 1. OUTLINE OF DIAGNOSIS

- Detect the open/short circuit of idle air control solenoid valve.
- Judge NG when the output terminal is Low level even though ECM outputs OFF signal.

#### 2. COMPONENT DESCRIPTION

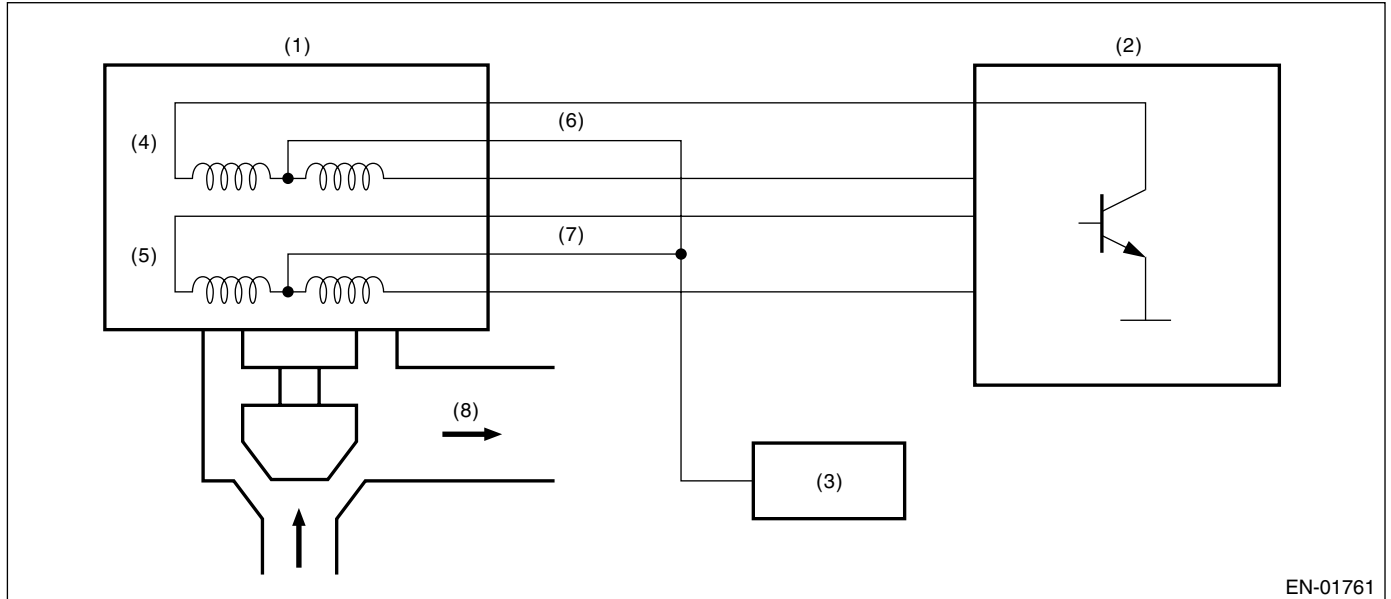

EN-01761

- |                                     |                   |                   |
|-------------------------------------|-------------------|-------------------|
| (1) Idle air control solenoid valve | (4) A phase       | (7) B phase power |
| (2) Engine control module (ECM)     | (5) B phase       | (8) Intake air    |
| (3) Ignition relay                  | (6) A phase power |                   |

#### 3. ENABLE CONDITION

Secondary Parameters	Enable Conditions
Starter switch	OFF
Battery voltage	> 10.9 V

#### 4. GENERAL DRIVING CYCLE

Perform the diagnosis continuously when starter switch is OFF.

# DIAGNOSTIC TROUBLE CODE (DTC) DETECTING CRITERIA

GENERAL DESCRIPTION

## 5. DIAGNOSTIC METHOD

### • Abnormality Judgment

Judge NG when the cumulative time until completing the malfunction criteria below becomes more than time needed for diagnosis.

### • Judgment Value

Malfunction Criteria	Threshold Value
Terminal voltage level when ECM outputs OFF signal	Low level

**Time Needed for Diagnosis:** 0.5 seconds

**Malfunction Indicator Light Illumination:** Illuminates as soon as malfunction occurs.

### • Normality Judgment

Judge OK and clear the NG when the malfunction criteria below are completed.

### • Judgment Value

Malfunction Criteria	Threshold Value
Terminal voltage level when ECM outputs OFF signal	High level

## 6. DTC CLEAR CONDITION

- When the OK idling cycle is completed 40 times in a row
- When "Clear Memory" was performed

## 7. MALFUNCTION INDICATOR LIGHT CLEAR CONDITION

- When the OK driving cycle was completed 3 times in a row
- When "Clear Memory" was performed

## 8. FAIL SAFE

- Cut the fuel of all cylinders, #1 cylinder or #1, #2 cylinder according to throttle position, engine speed, vehicle speed.
- ISC closed loop compensation value becomes zero. [ISCCL = 0 (l/min)]

## 9. ECM OPERATION AT DTC SETTING

Memorize the freeze frame data. (For test mode \$02)

# DIAGNOSTIC TROUBLE CODE (DTC) DETECTING CRITERIA

## GENERAL DESCRIPTION

### DO:DTC P1515 — ISC SOLENOID VALVE SIGNAL #3 CIRCUIT MALFUNCTION (HIGH INPUT) —

#### 1. OUTLINE OF DIAGNOSIS

- Detect the open/short circuit of idle air control solenoid valve.
- Judge NG when the output terminal is High level even though ECM outputs ON signal.

#### 2. COMPONENT DESCRIPTION

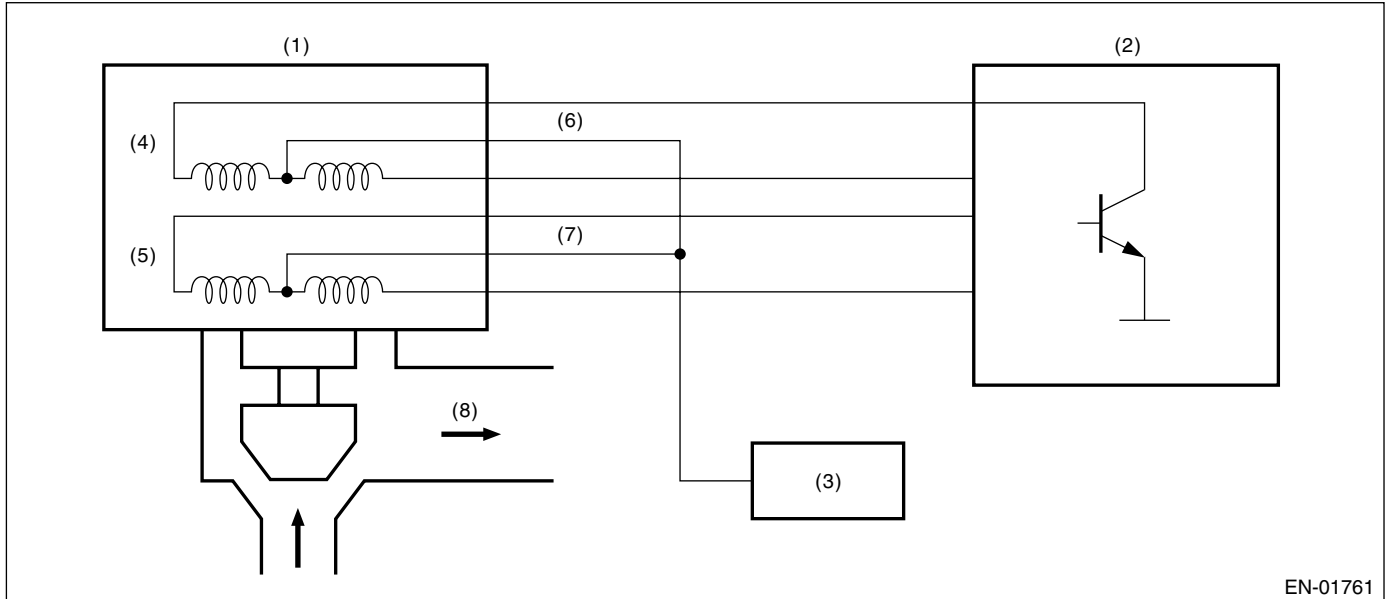

- |                                     |                   |                   |
|-------------------------------------|-------------------|-------------------|
| (1) Idle air control solenoid valve | (4) A phase       | (7) B phase power |
| (2) Engine control module (ECM)     | (5) B phase       | (8) Intake air    |
| (3) Ignition relay                  | (6) A phase power |                   |

#### 3. ENABLE CONDITION

Secondary Parameters	Enable Conditions
Starter switch	OFF
Battery voltage	> 10.9 V

#### 4. GENERAL DRIVING CYCLE

Perform the diagnosis continuously when starter switch is OFF.



# DIAGNOSTIC TROUBLE CODE (DTC) DETECTING CRITERIA

GENERAL DESCRIPTION

## 5. DIAGNOSTIC METHOD

### • Abnormality Judgment

Judge NG when the cumulative time until completing the malfunction criteria below becomes more than time needed for diagnosis.

### • Judgment Value

Malfunction Criteria	Threshold Value
Terminal voltage level when ECM outputs ON signal	High level

**Time Needed for Diagnosis:** 0.5 seconds

**Malfunction Indicator Light Illumination:** Illuminates as soon as malfunction occurs.

### • Normality Judgment

Judge OK and clear the NG when the malfunction criteria below are completed.

### • Judgment Value

Malfunction Criteria	Threshold Value
Terminal voltage level when ECM outputs ON signal	Low level

## 6. DTC CLEAR CONDITION

- When the OK idling cycle is completed 40 times in a row
- When "Clear Memory" was performed

## 7. MALFUNCTION INDICATOR LIGHT CLEAR CONDITION

- When the OK driving cycle was completed 3 times in a row
- When "Clear Memory" was performed

## 8. FAIL SAFE

- Cut the fuel of all cylinders, #1 cylinder or #1, #2 cylinder according to throttle position, engine speed, vehicle speed.
- ISC closed loop compensation value becomes zero. [ISCCL = 0 (l/min)]

## 9. ECM OPERATION AT DTC SETTING

Memorize the freeze frame data. (For test mode \$02)

# DIAGNOSTIC TROUBLE CODE (DTC) DETECTING CRITERIA

## GENERAL DESCRIPTION

### DP:DTC P1516 — ISC SOLENOID VALVE SIGNAL #4 CIRCUIT MALFUNCTION (LOW INPUT) —

#### 1. OUTLINE OF DIAGNOSIS

- Detect the open/short circuit of idle air control solenoid valve.
- Judge NG when the output terminal is Low level even though ECM outputs OFF signal.

#### 2. COMPONENT DESCRIPTION

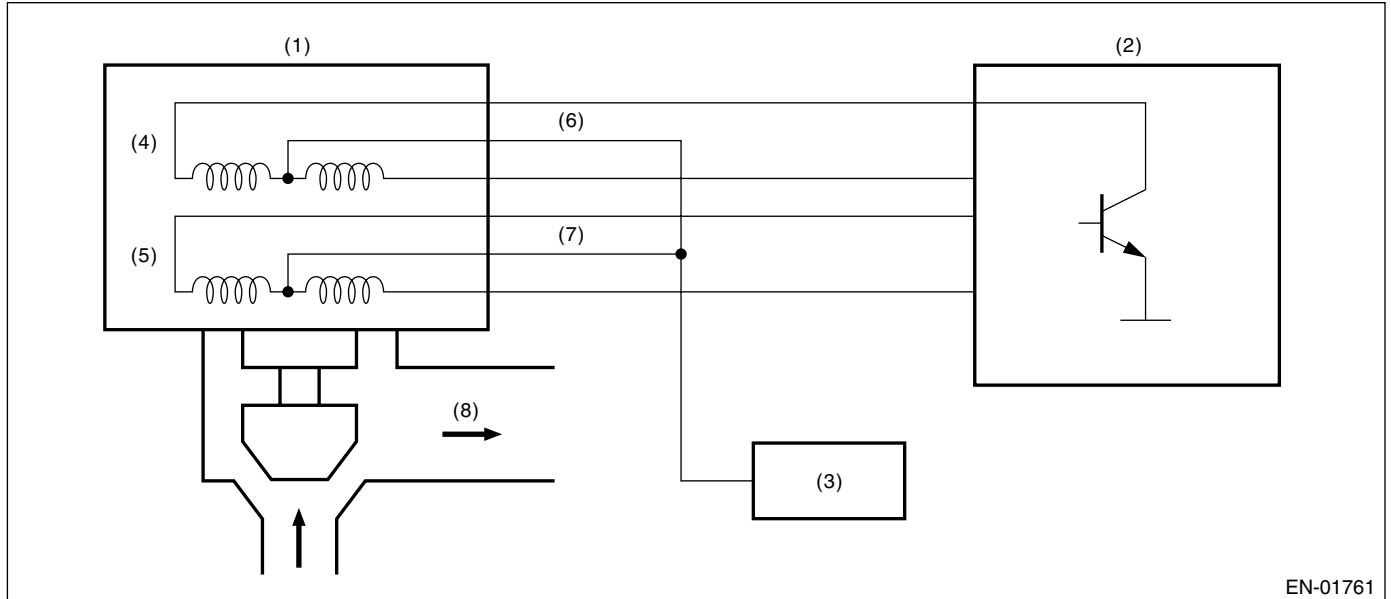

- |                                     |                   |                   |
|-------------------------------------|-------------------|-------------------|
| (1) Idle air control solenoid valve | (4) A phase       | (7) B phase power |
| (2) Engine control module (ECM)     | (5) B phase       | (8) Intake air    |
| (3) Ignition relay                  | (6) A phase power |                   |

#### 3. ENABLE CONDITION

Secondary Parameters	Enable Conditions
Starter switch	OFF
Battery voltage	> 10.9 V

#### 4. GENERAL DRIVING CYCLE

Perform the diagnosis continuously when starter switch is OFF.

# DIAGNOSTIC TROUBLE CODE (DTC) DETECTING CRITERIA

GENERAL DESCRIPTION

## 5. DIAGNOSTIC METHOD

### • Abnormality Judgment

Judge NG when the cumulative time until completing the malfunction criteria below becomes more than time needed for diagnosis.

### • Judgment Value

Malfunction Criteria	Threshold Value
Terminal voltage level when ECM outputs OFF signal	Low level

**Time Needed for Diagnosis:** 0.5 seconds

**Malfunction Indicator Light Illumination:** Illuminates as soon as malfunction occurs.

### • Normality Judgment

Judge OK and clear the NG when the malfunction criteria below are completed.

### • Judgment Value

Malfunction Criteria	Threshold Value
Terminal voltage level when ECM outputs OFF signal	High level

## 6. DTC CLEAR CONDITION

- When the OK idling cycle is completed 40 times in a row
- When "Clear Memory" was performed

## 7. MALFUNCTION INDICATOR LIGHT CLEAR CONDITION

- When the OK driving cycle was completed 3 times in a row
- When "Clear Memory" was performed

## 8. FAIL SAFE

- Cut the fuel of all cylinders, #1 cylinder or #1, #2 cylinder according to throttle position, engine speed, vehicle speed.
- ISC closed loop compensation value becomes zero. [ISCCL = 0 (l/min)]

## 9. ECM OPERATION AT DTC SETTING

Memorize the freeze frame data. (For test mode \$02)

# DIAGNOSTIC TROUBLE CODE (DTC) DETECTING CRITERIA

## GENERAL DESCRIPTION

### DQ:DTC P1517 — ISC SOLENOID VALVE SIGNAL #4 CIRCUIT MALFUNCTION (HIGH INPUT) —

#### 1. OUTLINE OF DIAGNOSIS

- Detect the open/short circuit of idle air control solenoid valve.
- Judge NG when the output terminal is High level even though ECM outputs ON signal.

#### 2. COMPONENT DESCRIPTION

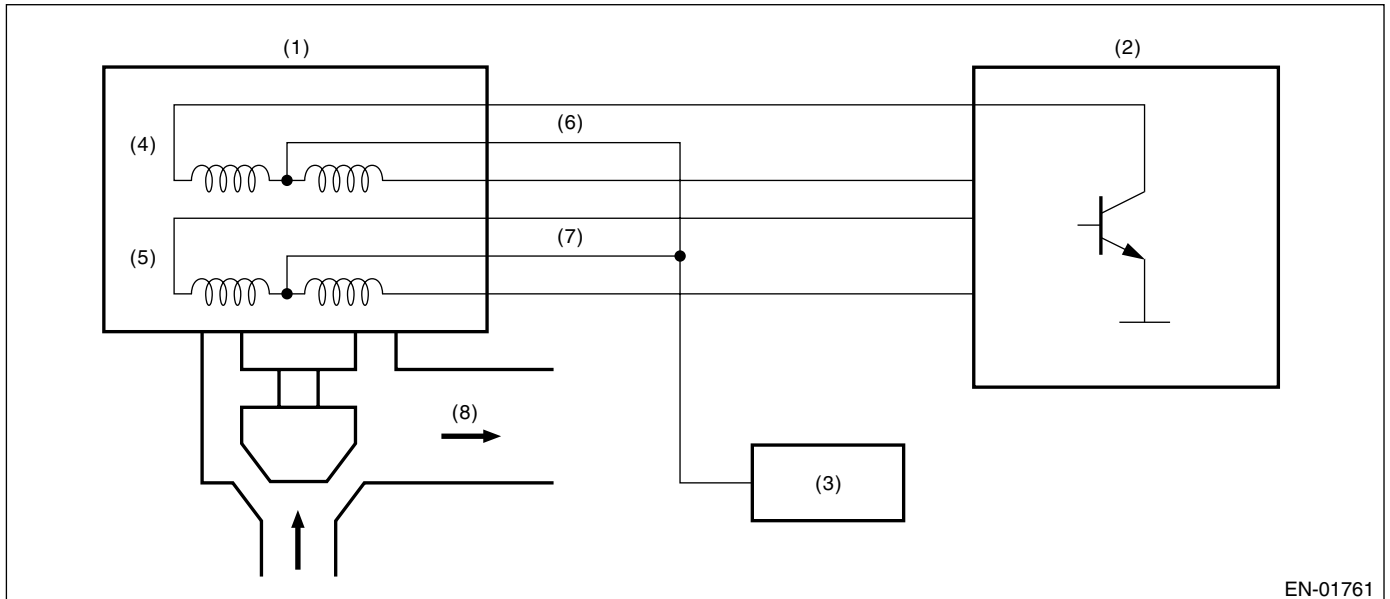

EN-01761

- |                                     |                   |                   |
|-------------------------------------|-------------------|-------------------|
| (1) Idle air control solenoid valve | (4) A phase       | (7) B phase power |
| (2) Engine control module (ECM)     | (5) B phase       | (8) Intake air    |
| (3) Ignition relay                  | (6) A phase power |                   |

#### 3. ENABLE CONDITION

Secondary Parameters	Enable Conditions
Starter switch	OFF
Battery voltage	> 10.9 V

#### 4. GENERAL DRIVING CYCLE

Perform the diagnosis continuously when starter switch is OFF.

# DIAGNOSTIC TROUBLE CODE (DTC) DETECTING CRITERIA

GENERAL DESCRIPTION

## 5. DIAGNOSTIC METHOD

### • Abnormality Judgment

Judge NG when the cumulative time until completing the malfunction criteria below becomes more than time needed for diagnosis.

### • Judgment Value

Malfunction Criteria	Threshold Value
Terminal voltage level when ECM outputs ON signal	High level

**Time Needed for Diagnosis:** 0.5 seconds

**Malfunction Indicator Light Illumination:** Illuminates as soon as malfunction occurs.

### • Normality Judgment

Judge OK and clear the NG when the malfunction criteria below are completed.

### • Judgment Value

Malfunction Criteria	Threshold Value
Terminal voltage level when ECM outputs ON signal	Low level

## 6. DTC CLEAR CONDITION

- When the OK idling cycle is completed 40 times in a row
- When "Clear Memory" was performed

## 7. MALFUNCTION INDICATOR LIGHT CLEAR CONDITION

- When the OK driving cycle was completed 3 times in a row
- When "Clear Memory" was performed

## 8. FAIL SAFE

- Cut the fuel of all cylinders, #1 cylinder or #1, #2 cylinder according to throttle position, engine speed, vehicle speed.
- ISC closed loop compensation value becomes zero. [ISCCL = 0 (l/min)]

## 9. ECM OPERATION AT DTC SETTING

Memorize the freeze frame data. (For test mode \$02)

# DIAGNOSTIC TROUBLE CODE (DTC) DETECTING CRITERIA

## GENERAL DESCRIPTION

---

### DR:DTC P1518 — STARTER SWITCH CIRCUIT LOW INPUT —

#### 1. OUTLINE OF DIAGNOSIS

- Detect the open/short circuit of starter switch.
- Judge OFF NG when the starter signal remains ON even though engine speed and vehicle speed are high.

#### 2. ENABLE CONDITION

Secondary Parameters	Enable Conditions
Engine	Run

#### 3. GENERAL DRIVING CYCLE

Perform the diagnosis continuously after starting engine.

#### 4. DIAGNOSTIC METHOD

Judge NG when all the malfunction criteria below are completed after more than 10 seconds.

Judge OK when the starter switch is turned from ON to OFF, and then NG are cleared.

#### Judgment value

Malfunction Criteria	Threshold Value
Engine speed	≥ 1500 rpm
Vehicle speed	≥ 30 km/h (19 MPH)
Starter "OFF" signal	Not detected

#### Time Needed for Diagnosis

OFF side                      10 seconds

**Malfunction Indicator Light Illumination:** Illuminates when malfunction occurs in 2 continuous driving cycles.

#### 5. DTC CLEAR CONDITION

- When the OK idling cycle is completed 40 times in a row
- When "Clear Memory" was performed

#### 6. MALFUNCTION INDICATOR LIGHT CLEAR CONDITION

- When the OK driving cycle was completed 3 times in a row
- When "Clear Memory" was performed

#### 7. FAIL SAFE

None

#### 8. ECM OPERATION AT DTC SETTING

Memorize the freeze frame data. (For test mode \$02)

# DIAGNOSTIC TROUBLE CODE (DTC) DETECTING CRITERIA

GENERAL DESCRIPTION

## DS:DTC P1560 — BACK-UP VOLTAGE CIRCUIT MALFUNCTION —

### 1. OUTLINE OF DIAGNOSIS

- Detect the open/short circuit of back-up power supply circuit.
- Judge NG when the back-up power supply does not come to ECM regardless of the battery voltage coming.

### 2. ENABLE CONDITION

Secondary Parameters	Enable Conditions
Self-diagnosis timer after starting the engine	$\geq 5$ seconds
Battery voltage MVB	$\geq 9.2$ V

### 3. GENERAL DRIVING CYCLE

Always perform the diagnosis continuously in 5 seconds after starting the engine.

### 4. DIAGNOSTIC METHOD

Judge NG and clear the NG when the cumulative time until completing the malfunction criteria below becomes more than the time (5 seconds) needed for diagnosis.

#### Judgment Value

Malfunction Criteria	Threshold Value
Battery back-up voltage	Battery voltage $\times 0.7$

**Time Needed for Diagnosis:** 5 seconds

**Malfunction indicator Light Illumination:** Illuminates as soon as malfunction occurs.

### 5. DTC CLEAR CONDITION

- When the OK idling cycle is completed 40 times in a row
- When "Clear Memory" was performed

### 6. MALFUNCTION INDICATOR LIGHT CLEAR CONDITION

- When the OK driving cycle is completed 3 times in a row
- When "Clear Memory" was performed

### 7. FAIL SAFE

None

### 8. ECM OPERATION AT DTC SETTING

Memorize the freeze frame data. (For test mode \$02)

# DIAGNOSTIC TROUBLE CODE (DTC) DETECTING CRITERIA

## GENERAL DESCRIPTION

### DT:DTC P1698 — ENGINE TORQUE CONTROL CUT SIGNAL CIRCUIT MALFUNCTION (LOW INPUT) —

#### 1. OUTLINE OF DIAGNOSIS

- Detect the open/short circuit of AT cooperative signal line.
- Judge NG when ECM output level is different from actual terminal level.

#### 2. ENABLE CONDITION

Secondary Parameters	Enable Conditions
Engine speed	≥ 500 rpm
Battery voltage	≥ 8.0 V
After engine starting	1 second or more

#### 3. GENERAL DRIVING CYCLE

Perform the diagnosis continuously after starting the engine.

#### 4. DIAGNOSTIC METHOD

##### • Abnormality Judgment

Judge NG when the cumulative time until completing the malfunction criteria below becomes more than the time (0.5 seconds) needed for diagnosis.

##### • Judgment Value

Malfunction Criteria	Threshold Value
Terminal voltage when ECM outputs OFF signal	Low

**Time Needed for Diagnosis:** 0.5 seconds

**Malfunction Indicator Light Illumination:** Illuminates when malfunction occurs in 2 continuous driving cycles.

##### • Normality Judgment

Judge OK and clear the NG when the malfunction criteria below are completed.

##### • Judgment Value

Malfunction Criteria	Threshold Value
Terminal voltage when ECM outputs OFF signal	High

#### 5. DTC CLEAR CONDITION

- When the OK idling cycle is completed 40 times in a row
- When "Clear Memory" was performed

#### 6. MALFUNCTION INDICATOR LIGHT CLEAR CONDITION

- When the OK driving cycle was completed 3 times in a row
- When "Clear Memory" was performed

#### 7. FAIL SAFE

None

#### 8. ECM OPERATION AT DTC SETTING

Memorize the freeze frame data. (For test mode \$02)



# DIAGNOSTIC TROUBLE CODE (DTC) DETECTING CRITERIA

GENERAL DESCRIPTION

## DU:DTC P1699 — ENGINE TORQUE CONTROL CUT SIGNAL CIRCUIT MALFUNCTION (HIGH INPUT) —

### 1. OUTLINE OF DIAGNOSIS

- Detect the open/short circuit of AT cooperative signal line.
- Judge NG when ECM output level is different from actual terminal level.

### 2. ENABLE CONDITION

Secondary Parameters	Enable Conditions
Engine speed	≥ 500 rpm
Battery voltage	≥ 8.0 V
After engine starting	1 second or more

### 3. GENERAL DRIVING CYCLE

Perform the diagnosis continuously after starting the engine.

### 4. DIAGNOSTIC METHOD

#### • Abnormality Judgment

Judge NG when the cumulative time until completing the malfunction criteria below becomes more than the time (0.5 seconds) needed for diagnosis.

#### • Judgment Value

Malfunction Criteria	Threshold Value
Terminal voltage when ECM outputs ON signal	High

**Time Needed for Diagnosis:** 0.5 seconds

**Malfunction Indicator Light Illumination:** Illuminates when malfunction occurs in 2 continuous driving cycles.

#### • Normality Judgment

Judge OK and clear the NG when the malfunction criteria below are completed.

#### • Judgment Value

Malfunction Criteria	Threshold Value
Terminal voltage when ECM outputs ON signal	Low

### 5. DTC CLEAR CONDITION

- When the OK idling cycle is completed 40 times in a row
- When “Clear Memory” was performed

### 6. MALFUNCTION INDICATOR LIGHT CLEAR CONDITION

- When the OK driving cycle was completed 3 times in a row
- When “Clear Memory” was performed

### 7. FAIL SAFE

None

### 8. ECM OPERATION AT DTC SETTING

Memorize the freeze frame data. (For test mode \$02)

# DIAGNOSTIC TROUBLE CODE (DTC) DETECTING CRITERIA

## GENERAL DESCRIPTION

### DV:DTC P1700 — THROTTLE POSITION SENSOR CIRCUIT MALFUNCTION FOR AT —

#### 1. OUTLINE OF DIAGNOSIS

Judge NG when the voltage from throttle sensor is out of specified value.

#### 2. COMPONENT DESCRIPTION

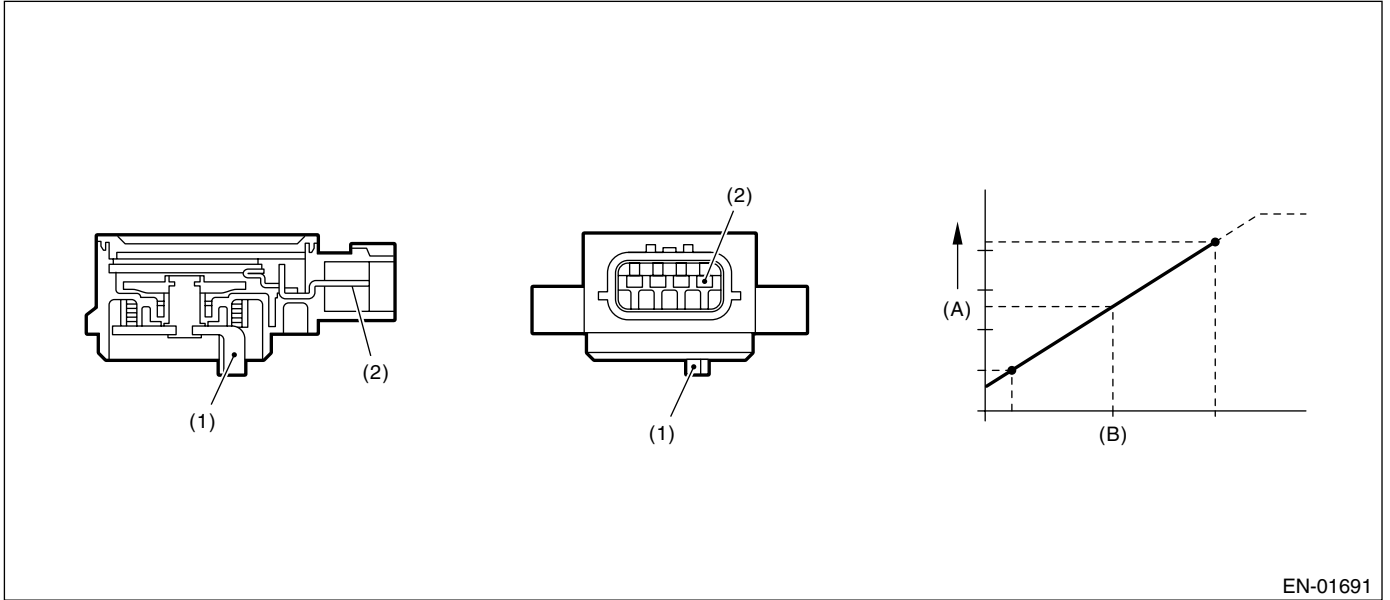

EN-01691

(1) Lever

(2) Terminal

(A) Output voltage

(B) Throttle valve angle

#### 3. ENABLE CONDITION

Secondary Parameters	Enable Conditions
None	

#### 4. GENERAL DRIVING CYCLE

Always perform the diagnosis continuously.

#### 5. DIAGNOSTIC METHOD

##### Judgment Value

Malfunction Criteria	Threshold Value
Output voltage	$\leq 0.1$ or $\geq 4.6$ V

**Time Needed for Diagnosis:** 63.75 seconds

**Malfunction Indicator Light Illumination:** Illuminates when malfunction occurs in 2 continuous driving cycles.

#### 6. DTC CLEAR CONDITION

- When the OK idling cycle was completed 40 times in a row
- When "Clear Memory" was performed

#### 7. MALFUNCTION INDICATOR LIGHT CLEAR CONDITION

- When the OK driving cycle was completed 3 times in a row
- When "Clear Memory" was performed

# DIAGNOSTIC TROUBLE CODE (DTC) DETECTING CRITERIA

GENERAL DESCRIPTION

---

## 8. FAIL SAFE

Make the throttle angle to 3/8 open, and the line pressure and 2-4B pressure to maximum.

## 9. ECM OPERATION AT DTC SETTING

Memorize the freeze frame data. (For test mode \$02)

# DIAGNOSTIC TROUBLE CODE (DTC) DETECTING CRITERIA

## GENERAL DESCRIPTION

---

### DW:DTC P1711 — ENGINE TORQUE CONTROL SIGNAL #1 CIRCUIT MALFUNCTION —

#### 1. OUTLINE OF DIAGNOSIS

Judge NG when detecting the difference 250 times in a row by comparing the CPU output with signal line output every 10 milliseconds.

#### 2. ENABLE CONDITION

Secondary Parameters	Enable Conditions
None	

#### 3. GENERAL DRIVING CYCLE

Always perform the diagnosis continuously.

#### 4. DIAGNOSTIC METHOD

##### Judgment Value

Malfunction Criteria	Threshold Value
Collector voltage of transistor (Vc) at "ON" signal from TCM	High level
Collector voltage of transistor (Vc) at "OFF" signal from ECM	Low level

**Time Needed for Diagnosis:** 2.5 seconds

**Malfunction Indicator Light Illumination:** Illuminates when malfunction occurs in 2 continuous driving cycles.

#### 5. DTC CLEAR CONDITION

- When the OK idling cycle was completed 40 times in a row
- When "Clear Memory" was performed

#### 6. MALFUNCTION INDICATOR LIGHT CLEAR CONDITION

- When the OK driving cycle was completed 3 times in a row
- When "Clear Memory" was performed

#### 7. FAIL SAFE

None

#### 8. ECM OPERATION AT DTC SETTING

Memorize the freeze frame data. (For test mode \$02)

# DIAGNOSTIC TROUBLE CODE (DTC) DETECTING CRITERIA

GENERAL DESCRIPTION

## DX:DTC P1712 — ENGINE TORQUE CONTROL SIGNAL #2 CIRCUIT MALFUNCTION —

### 1. OUTLINE OF DIAGNOSIS

Judge NG when detecting the difference 250 times in a row by comparing the CPU output with signal line output every 10 milliseconds.

### 2. ENABLE CONDITION

Secondary Parameters	Enable Conditions
None	

### 3. GENERAL DRIVING CYCLE

Always perform the diagnosis continuously.

### 4. DIAGNOSTIC METHOD

#### Judgment Value

Malfunction Criteria	Threshold Value
Vc at "ON" signal from ECM	High
Vc at "OFF" signal from ECM	Low

**Time Needed for Diagnosis:** 2.5 seconds

**Malfunction Indicator Light Illumination:** Illuminates when malfunction occurs in 2 continuous driving cycles.

### 5. DTC CLEAR CONDITION

- When the OK idling cycle was completed 40 times in a row
- When "Clear Memory" was performed

### 6. MALFUNCTION INDICATOR LIGHT CLEAR CONDITION

- When the OK driving cycle was completed 3 times in a row
- When "Clear Memory" was performed

### 7. FAIL SAFE

None

### 8. ECM OPERATION AT DTC SETTING

Memorize the freeze frame data. (For test mode \$02)

# DIAGNOSTIC TROUBLE CODE (DTC) DETECTING CRITERIA

## GENERAL DESCRIPTION

### DY:DTC P2096 — POST CATALYST FUEL TRIM SYSTEM TOO LEAN BANK 1 —

#### 1. OUTLINE OF DIAGNOSIS

Detect the malfunction of fuel system from the amount of sub feedback control.

Judge NG when the rear oxygen sensor output does not approach to the slice level (target voltage) with the control amount sticks to rich or lean side while operating the sub feedback control.

#### 2. COMPONENT DESCRIPTION

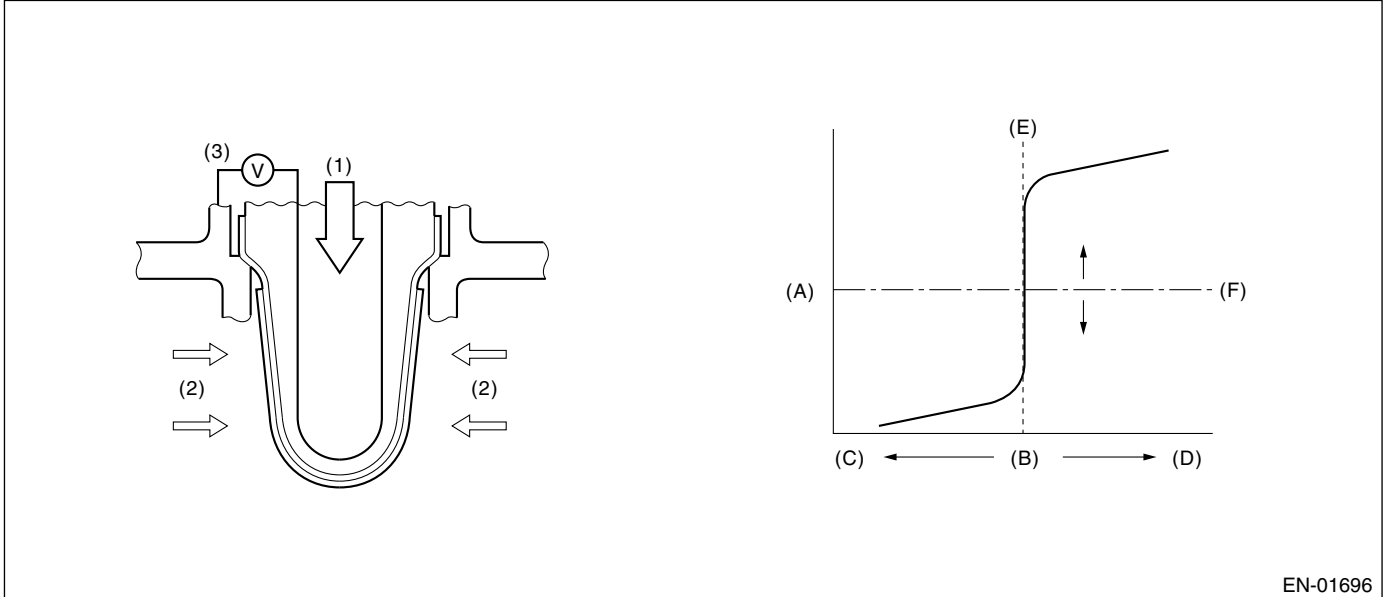

EN-01696

- (1) Atmosphere
- (2) Exhaust gas
- (3) Electromotive force

- (A) Electromotive force
- (B) Air fuel ratio
- (C) Lean

- (D) Rich
- (E) Theoretical air fuel ratio
- (F) Comparative voltage

#### 3. ENABLE CONDITION

Secondary Parameters	Enable Conditions
Fuel system monitoring with primary oxygen sensor	In operation
Target lambda with primary oxygen sensor	1.0
Closed loop control with secondary oxygen sensor	In operation
Amount of intake air	$\geq 20$ kg (0.71 oz)/h
Feed back control with secondary oxygen sensor	Reached to the limit value

#### 4. GENERAL DRIVING CYCLE

Perform the diagnosis continuously at a constant speed of more than 20 km/h (12 MPH).

# DIAGNOSTIC TROUBLE CODE (DTC) DETECTING CRITERIA

GENERAL DESCRIPTION

## 5. DIAGNOSTIC METHOD

### • Abnormality Judgment

Calculate the continuous time from the sticking of sub feedback control amount to rich or lean side and cumulative deviation (sumdelo2) of rear oxygen sensor voltage and slice level (target voltage).

Judge NG when the malfunction criteria below are completed after 300 seconds have passed continuously.

### • Judgment Value

Malfunction Criteria	Threshold Value
$\text{sumdelo2} = \text{sumdelo2} + (\text{rvo2} - \text{rsl})$ where: rvo2 = sensing voltage of secondary oxygen sensor rsl = target voltage of secondary oxygen sensor	< -8000 V

**Time Needed for Diagnosis:** 300 seconds

**Malfunction Indicator Light Illumination:** Illuminates when malfunction occurs in 2 continuous driving cycles.

### • Normality Judgment

Judge OK and clear the NG when the rear oxygen output is reversed, and during 4 seconds after that, the sub feedback control amount does not stick to rich or lean sides.

## 6. DTC CLEAR CONDITION

- When the OK idling cycle was completed 40 times in a row
- When "Clear Memory" was performed

## 7. MALFUNCTION INDICATOR LIGHT CLEAR CONDITION

- When the OK driving cycle was completed 3 times in a row
- When "Clear Memory" was performed

## 8. FAIL SAFE

None

## 9. ECM OPERATION AT DTC SETTING

Memorize the freeze frame data. (For test mode \$02)

# DIAGNOSTIC TROUBLE CODE (DTC) DETECTING CRITERIA

## GENERAL DESCRIPTION

### DZ:DTC P2097 — POST CATALYST FUEL TRIM SYSTEM TOO RICH BANK 1 —

#### 1. OUTLINE OF DIAGNOSIS

Detect the malfunction of fuel system from the amount of sub feedback control.

Judge NG when the rear oxygen sensor output does not approach to the slice level (target voltage) with the control amount sticks to rich or lean side while operating the sub feedback control.

#### 2. COMPONENT DESCRIPTION

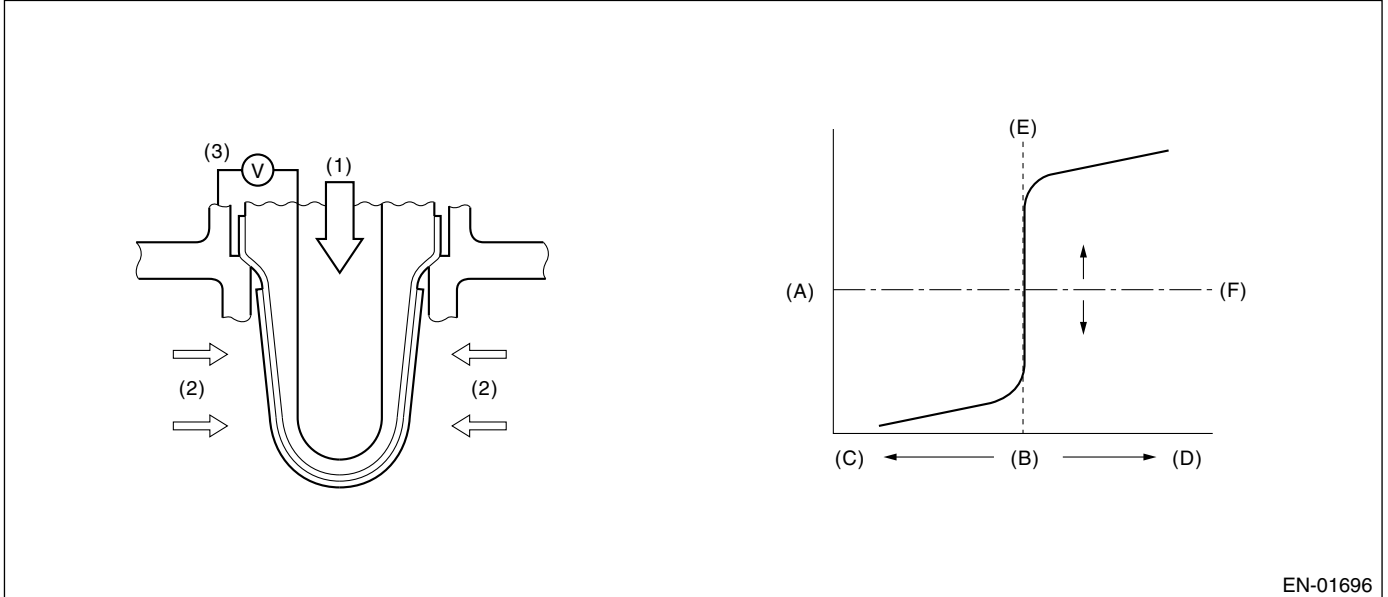

EN-01696

- (1) Atmosphere
- (2) Exhaust gas
- (3) Electromotive force

- (A) Electromotive force
- (B) Air fuel ratio
- (C) Lean

- (D) Rich
- (E) Theoretical air fuel ratio
- (F) Comparative voltage

#### 3. ENABLE CONDITION

Secondary Parameters	Enable Conditions
Fuel system monitoring with primary oxygen sensor	In operation
Target lambda with primary oxygen sensor	1.0
Closed loop control with secondary oxygen sensor	In operation
Amount of intake air	$\geq 20$ kg (0.71 oz)/h
Feed back control with secondary oxygen sensor	Reached to the limit value

#### 4. GENERAL DRIVING CYCLE

Perform the diagnosis continuously at a constant 80 km/h (50 MPH).



# DIAGNOSTIC TROUBLE CODE (DTC) DETECTING CRITERIA

GENERAL DESCRIPTION

## 5. DIAGNOSTIC METHOD

### • Abnormality Judgment

Calculate the continuous time from the sticking of sub feedback control amount to rich or lean side and cumulative deviation (sumdelo2) of rear oxygen sensor voltage and slice level (target voltage).

Judge NG when the malfunction criteria below are completed after 300 seconds have passed continuously.

### • Judgment Value

Malfunction Criteria	Threshold Value
$\text{sumdelo2} = \text{sumdelo2} + (\text{rvo2} - \text{rsl})$ where: rvo2 = sensing voltage of secondary oxygen sensor rsl = target voltage of secondary oxygen sensor	> 2300 V

**Time Needed for Diagnosis:** 300 seconds

**Malfunction Indicator Light Illumination:** Illuminates when malfunction occurs in 2 continuous driving cycles.

### • Normality Judgment

Judge OK and clear the NG when the rear oxygen output is reversed, and during 4 seconds after that, the sub feedback control amount does not stick to rich or lean sides.

## 6. DTC CLEAR CONDITION

- When the OK idling cycle was completed 40 times in a row
- When "Clear Memory" was performed

## 7. MALFUNCTION INDICATOR LIGHT CLEAR CONDITION

- When the OK driving cycle was completed 3 times in a row
- When "Clear Memory" was performed

## 8. FAIL SAFE

None

## 9. ECM OPERATION AT DTC SETTING

Memorize the freeze frame data. (For test mode \$02)

# DIAGNOSTIC TROUBLE CODE (DTC) DETECTING CRITERIA

GENERAL DESCRIPTION

---

**MEMO:**