

INTAKE (INDUCTION)

IN(H4SO)

	Page
1. General Description	2
2. Air Cleaner	4
3. Air Cleaner Case	5
4. Air Intake Duct.....	6
5. Resonator Chamber	7

GENERAL DESCRIPTION

INTAKE (INDUCTION)

1. General Description

A: COMPONENT

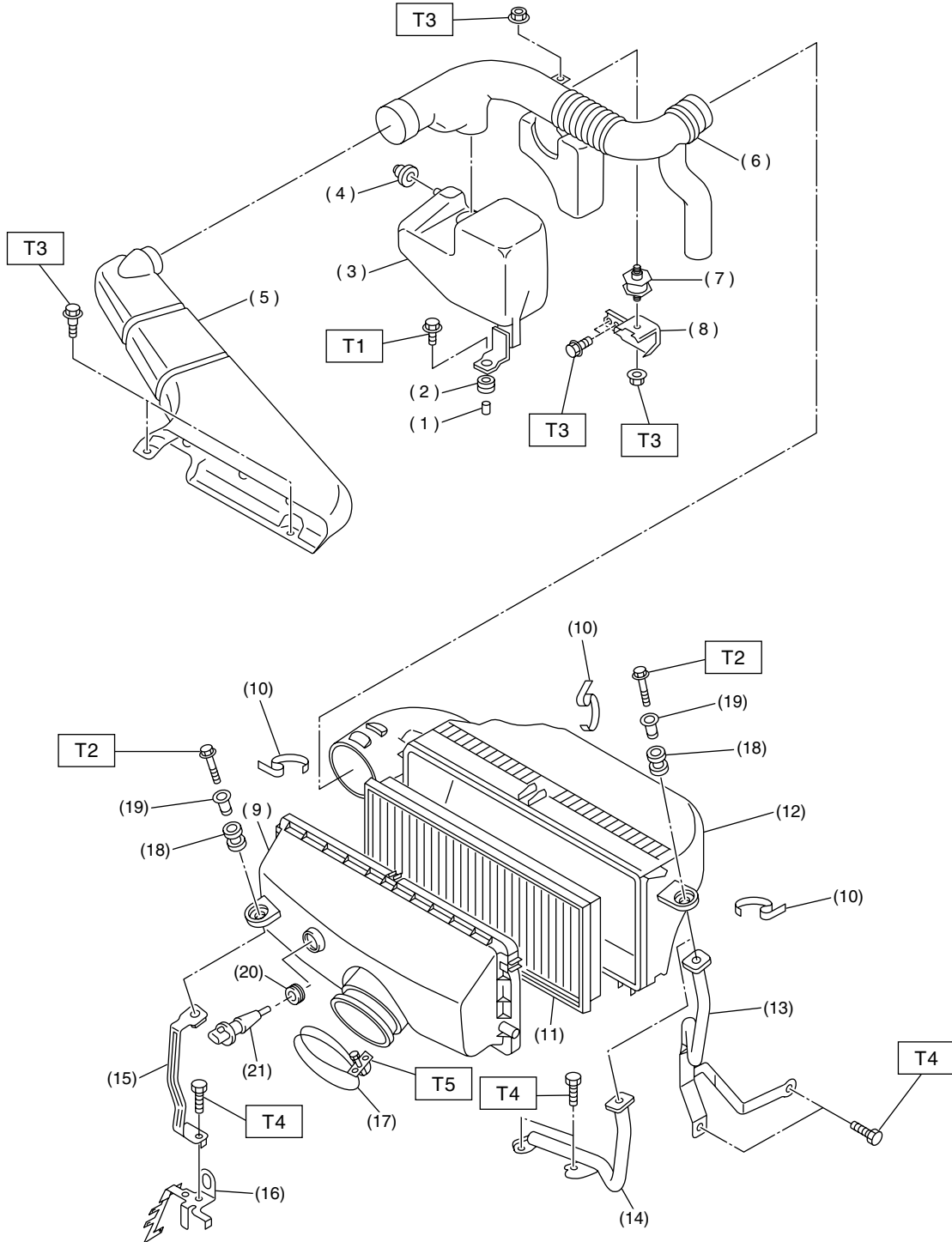

IN-00057

IN(H4SO)-2

GENERAL DESCRIPTION

INTAKE (INDUCTION)

(1) Spacer	(11) Air cleaner element	(19) Spacer
(2) Bushing	(12) Air cleaner case B	(20) Grommet
(3) Resonator chamber	(13) Air cleaner case stay LH (MT vehicles)	(21) Intake air temperature sensor
(4) Cushion rubber		
(5) Air intake duct A	(14) Air cleaner case stay LH (AT vehicles)	Tightening torque: N-m (kgf-m, ft-lb)
(6) Air intake duct B		T1: 33 (3.4, 24.6)
(7) Cushion	(15) Air cleaner case stay RH	T2: 6.5 (0.66, 4.8)
(8) Bracket	(16) Engine harness bracket	T3: 7.5 (0.76, 5.5)
(9) Air cleaner case A	(17) Clamp	T4: 16 (1.6, 11.6)
(10) Clip	(18) Bushing	T5: 3 (0.3, 2.2)

B: CAUTION

- Wear working clothing, including a cap, protective goggles, and protective shoes during operation.
- Remove contamination including dirt and corrosion before removal, installation or disassembly.
- Keep the disassembled parts in order and protect them from dust or dirt.
- Before removal, installation or disassembly, be sure to clarify the failure. Avoid unnecessary removal, installation, disassembly, and replacement.
- Be careful not to burn your hands, because each part on the vehicle is hot after running.
- Be sure to tighten fasteners including bolts and nuts to the specified torque.
- Place shop jacks or safety stands at the specified points.
- Before disconnecting electrical connectors of sensor or units, be sure to disconnect ground cable from battery.

AIR CLEANER

INTAKE (INDUCTION)

2. Air Cleaner

A: REMOVAL

- 1) Remove bolt (A) which install air cleaner case to stays.
- 2) Remove the clip (B) above the air cleaner case.

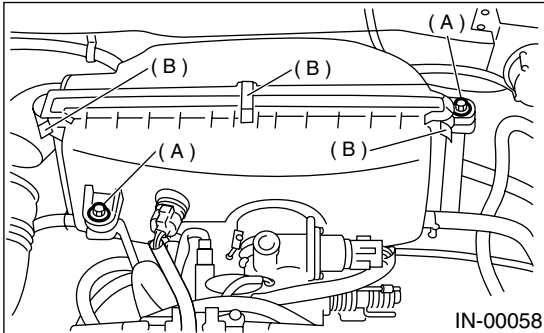

- 3) Remove air cleaner element.

B: INSTALLATION

Install in the reverse order of removal.

CAUTION:

Fasten with a clip after inserting the lower tab of the case.

C: INSPECTION

Replace if excessively damaged or dirty.

3. Air Cleaner Case

A: REMOVAL

- 1) Disconnect the ground cable from battery.

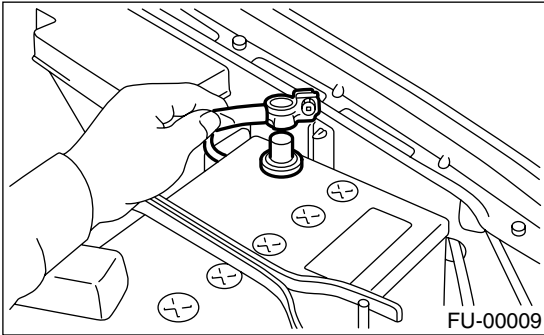

- 2) Disconnect the connector (A) of intake air temperature sensor.
- 3) Remove the bolts (B) which install air cleaner case to stay.

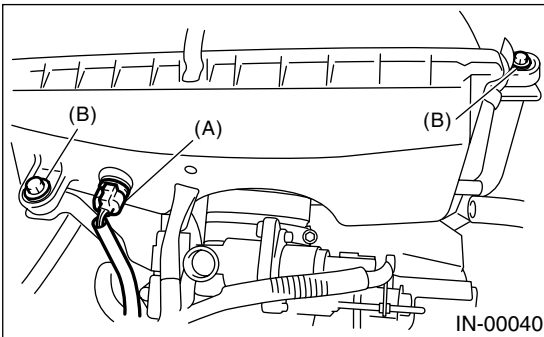

- 4) Disconnect the hoses and intake duct from air cleaner case.
- 5) Loosen the clamp which connects air cleaner case to throttle body.

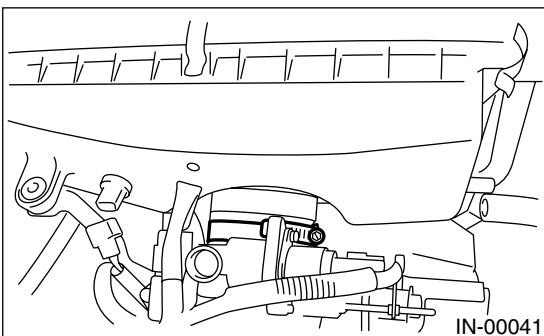

- 6) Remove the air cleaner case.

B: INSTALLATION

Install in the reverse order of removal.

C: INSPECTION

Inspect for cracks and loose connections.

AIR INTAKE DUCT

INTAKE (INDUCTION)

4. Air Intake Duct

A: REMOVAL

1) Remove bolts which install air intake duct on the front side of body.

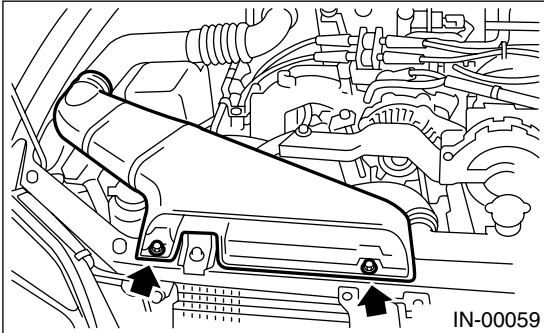

2) Remove bolt which installs air intake duct on body.

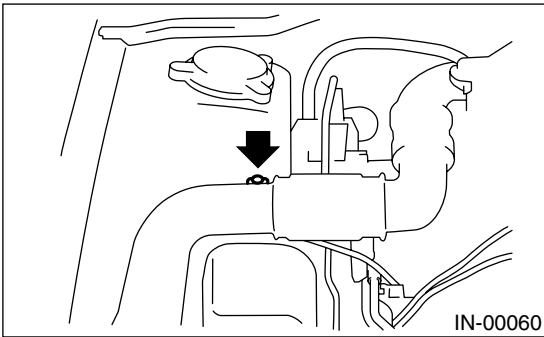

3) Remove air intake ducts as a unit.

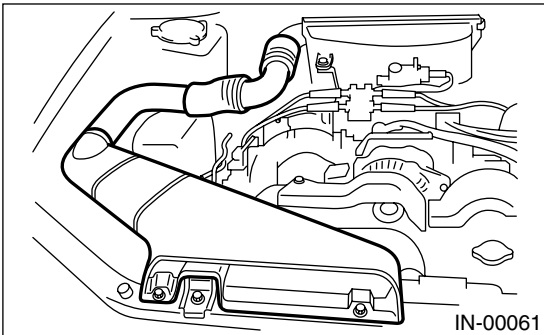

B: INSTALLATION

Install in the reverse order of removal.

C: INSPECTION

Inspect for cracks and loose connections. Check that no foreign objects are mixed in the air intake duct.

5. Resonator Chamber

A: REMOVAL

- 1) Remove air intake duct. <Ref. to IN(H4SO)-6, REMOVAL, Air Intake Duct.>
- 2) Remove resonator chamber.

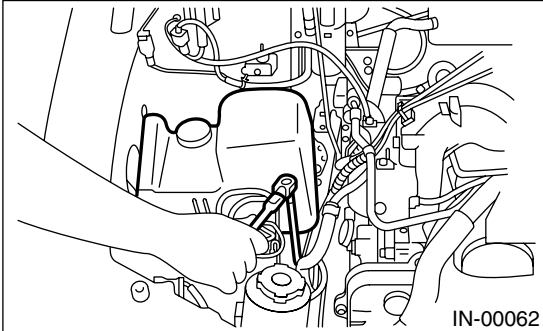

B: INSTALLATION

Install in the reverse order of removal.

Tightening torque:

33 N·m (3.4 kgf-m, 24.6 ft-lb)

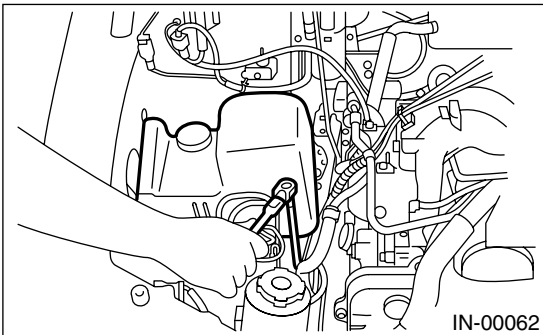

C: INSPECTION

Inspect for cracks and loose connections.

RESONATOR CHAMBER

INTAKE (INDUCTION)

MEMO:

IN(H4SO)-8