

MECHANICAL

ME(H4SO)

	Page
1. General Description	2
2. Compression	24
3. Idle Speed	25
4. Ignition Timing	26
5. Intake Manifold Vacuum	27
6. Engine Oil Pressure	28
7. Fuel Pressure	29
8. Valve Clearance	30
9. Engine Assembly	34
10. Engine Mounting	41
11. Preparation for Overhaul	42
12. V-belt	43
13. Crankshaft Pulley	45
14. Belt Cover	46
15. Timing Belt Assembly	47
16. Camshaft Sprocket	52
17. Crankshaft Sprocket	53
18. Valve Rocker Assembly	54
19. Camshaft	56
20. Cylinder Head Assembly	61
21. Cylinder Block	69
22. Engine Trouble in General	91
23. Engine Noise	96

GENERAL DESCRIPTION

MECHANICAL

1. General Description

A: SPECIFICATIONS

Engine	Type		Horizontally opposed, liquid cooled, 4-cylinder, 4-stroke gasoline engine		
	Valve arrangement		Belt driven, single over-head camshaft, 4-valve/cylinder		
	Bore x Stroke		mm (in)		
			99.5 x 79.0 (3.917 x 3.110)		
	Displacement		cm ³ (cu in)		
			2,457 (150)		
	Compression ratio		10.0		
	Compression pressure (at 200 — 300 rpm)		kPa (kg/cm ² , psi)		
			1,079 — 1,275 (11.0 — 13.0, 156 — 185)		
	Number of piston rings		Pressure ring: 2, Oil ring: 1		
	Intake valve timing	Opening		1° BTDC	
		Closing		51° ABDC	
	Exhaust valve timing	Opening		50° BBDC	
		Closing		6° ATDC*1 8° ATDC*2	
	Valve clearance	Intake	mm (in)	0.20±0.02 (0.0079±0.0008)	
Exhaust		mm (in)	0.25±0.02 (0.0098±0.0008)		
Idling speed [At neutral position on MT, or "P" or "N" position on AT]		rpm			
		MT: 650±100 (No load) AT: 700±100 (No load) 850±100 (A/C switch ON)			
Firing order		1 → 3 → 2 → 4			
Ignition timing		BTDC/rpm			
		MT: 10°±8°/650 AT: 15°±8°/700			

*1: Except U5 *2: U5

NOTE:

- STD: Standard I.D.: Inner Diameter O.D.: Outer Diameter US: Undersize OS: Oversize
- *1, *2 in tables on the following pages stand for: *1 Except U5, *2 U5 respectively

Belt tensioner adjuster	Protrusion of adjuster rod		5.2 — 6.2 mm (0.205 — 0.244 in)		
Belt tensioner	Spacer O.D.		17.955 — 17.975 mm (0.7069 — 0.7077 in)		
	Tensioner bushing I.D.		18.00 — 18.08 mm (0.7087 — 0.7118 in)		
	Clearance between spacer and bushing	STD	0.025 — 0.125 mm (0.0010 — 0.0049 in)		
		Limit	0.175 mm (0.0069 in)		
	Side clearance of spacer	STD	0.20 — 0.55 mm (0.0079 — 0.0217 in)		
Limit		0.81 mm (0.0319 in)			
Valve rocker arm	Clearance between shaft and arm		STD		
			Limit		
				0.020 — 0.054 mm (0.0008 — 0.0021 in) 0.10 mm (0.0039 in)	

GENERAL DESCRIPTION

MECHANICAL

Camshaft	Bend limit			0.025 mm (0.00098 in)	
	Thrust clearance		STD	0.030 — 0.090 mm (0.0012 — 0.0035 in)	
			Limit	0.10 mm (0.0039 in)	
	Cam lobe height		Intake	STD	39.485 — 39.585 mm (1.5545 — 1.5585 in)
				Limit	39.385 mm (1.5506 in)
			Exhaust*1	STD	39.257 — 39.357 mm (1.5455 — 1.5495 in)
				Limit	39.157 mm (1.5416 in)
			Exhaust*2	STD	39.843 — 39.943 mm (1.5686 — 1.5726 in)
				Limit	39.743 mm (1.5647 in)
	Camshaft journal O.D.				31.928 — 31.945 mm (1.2570 — 1.2577 in)
Camshaft journal hole I.D.				32.000 — 32.018 mm (1.2598 — 1.2605 in)	
Journal clearance		STD		0.055 — 0.090 mm (0.0022 — 0.0035 in)	
		Limit		0.10 mm (0.0039 in)	
Cylinder head	Surface warpage limit (mating surface with cylinder block)			0.05 mm (0.0020 in)	
	Surface grinding limit			0.1 mm (0.004 in)	
	Standard height			97.5 mm (3.839 in)	
Valve set	Refacing angle			90°	
	Contacting width		Intake	STD	1.1 mm (0.039 in)
				Limit	1.8 mm (0.067 in)
			Exhaust	STD	1.5 mm (0.055 in)
Limit				2.2 mm (0.083 in)	
Valve guide	Inner diameter			6.000 — 6.012 mm (0.2362 — 0.2367 in)	
	Protrusion above head		Intake	20.0 — 20.5 mm (0.787 — 0.807 in)	
			Exhaust	16.5 — 17.0 mm (0.650 — 0.669 in)	
Valve	Head edge thickness		Intake	STD	1.0 mm (0.039 in)
				Limit	0.6 mm (0.024 in)
			Exhaust	STD	1.2 mm (0.047 in)
				Limit	0.6 mm (0.024 in)
	Stem diameter		Intake	5.950 — 5.965 mm (0.2343 — 0.2348 in)	
			Exhaust	5.945 — 5.960 mm (0.2341 — 0.2346 in)	
	Stem oil clearance		STD	Intake	0.035 — 0.062 mm (0.0014 — 0.0024 in)
				Exhaust	0.040 — 0.067 mm (0.0016 — 0.0026 in)
		Limit	—	0.15 mm (0.0059 in)	
Overall length		Intake		120.6 mm (4.75 in)	
		Exhaust		121.7 mm (4.79 in)	
Valve spring	Free length			54.30 mm (2.1378 in)	
	Squareness			2.5°, 2.4 mm (0.094 in)	
	Tension/spring height		Set		214 — 246 N (21.8 — 25.1 kgf, 48.1 — 55.3 lb)/ 45.0 mm (1.772 in)
			Lift		526 — 582 N (53.7 — 59.4 kgf, 118.2 — 130.8 lb)/ 34.7 mm (1.366 in)

GENERAL DESCRIPTION

MECHANICAL

Cylinder block	Surface warpage limit (mating surface with cylinder head)			0.05 mm (0.0020 in)	
	Surface grinding limit			0.1 mm (0.004 in)	
	Cylinder bore	STD	A	99.505 — 99.515 mm (3.9175 — 3.9179 in)	
			B	99.495 — 99.505 mm (3.9171 — 3.9175 in)	
	Taper	STD		0.015 mm (0.0006 in)	
		Limit		0.050 mm (0.0020 in)	
	Out-of-roundness	STD		0.010 mm (0.0004 in)	
		Limit		0.050 mm (0.0020 in)	
Piston clearance			0.010 — 0.030 mm (0.0004 — 0.0012 in)*1 -0.010 — 0.010 (-0.0004 — 0.0004)*2		
Enlarging (boring) limit			0.5 mm (0.020 in)		
Piston	Outer diameter	*1	STD	A	99.485 — 99.495 mm (3.9167 — 3.9171 in)
				B	99.475 — 99.485 mm (3.9163 — 3.9167 in)
			0.25 mm (0.0098 in) OS		99.725 — 99.735 mm (3.9262 — 3.9266 in)
			0.50 mm (0.0197 in) OS		99.975 — 99.985 mm (3.9360 — 3.9364 in)
		*2	STD	A	99.505 — 99.515 mm (3.9175 — 3.9179 in)
				B	99.495 — 99.505 mm (3.9171 — 3.9175 in)
			0.25 mm (0.0098 in) OS		99.745 — 99.765 mm (3.9270 — 3.9278 in)
			0.50 mm (0.0197 in) OS		99.995 — 100.015 mm (3.9368 — 3.9376 in)
Standard inner diameter of piston pin hole			23.000 — 23.006 mm (0.9055 — 0.9057 in)		
Piston pin	Outer diameter			22.994 — 23.000 mm (0.9053 — 0.9055 in)	
	Standard clearance between piston pin and hole in piston			0.004 — 0.008 mm (0.0002 — 0.0003 in)	
	Degree of fit			Piston pin must be fitted into position with thumb at 20°C (68°F).	
Piston ring	Piston ring gap	Top ring	STD	0.20 — 0.35 mm (0.0079 — 0.0138 in)	
			Limit	1.0 mm (0.039 in)	
		Second ring	STD	0.37 — 0.52 mm (0.0146 — 0.0205 in)	
			Limit	1.0 mm (0.039 in)	
	Oil ring	STD	0.20 — 0.50 mm (0.0079 — 0.0197 in)		
		Limit	1.5 mm (0.059 in)		
	Clearance between piston ring and piston ring groove	Top ring	STD	0.040 — 0.080 mm (0.0016 — 0.0031 in)	
			Limit	0.15 mm (0.0059 in)	
Second ring		STD	0.030 — 0.070 mm (0.0012 — 0.0028 in)		
		Limit	0.15 mm (0.0059 in)		
Connecting rod	Bend twist per 100 mm (3.94 in) in length		Limit	0.10 mm (0.0039 in)	
	Side clearance	STD	0.070 — 0.330 mm (0.0028 — 0.0130 in)		
		Limit	0.4 mm (0.016 in)		
	Connecting rod bearing	Oil clearance		STD	0.016 — 0.044 (0.0006 — 0.0017 in)
Limit				0.05 mm (0.0020 in)	
Thickness at center portion		STD	1.490 — 1.502 mm (0.0587 — 0.0591 in)		
		0.03 mm (0.0012 in) US	1.504 — 1.513 mm (0.0592 — 0.0596 in)		
		0.05 mm (0.0020 in) US	1.514 — 1.523 mm (0.0596 — 0.0600 in)		
		0.25 mm (0.0098 in) US	1.614 — 1.623 mm (0.0635 — 0.0639 in)		
Connecting rod bushing	Clearance between piston pin and bushing		STD	0 — 0.022 mm (0 — 0.0009 in)	
			Limit	0.030 mm (0.0012 in)	

GENERAL DESCRIPTION

MECHANICAL

Crankshaft	Bend limit		0.035 mm (0.0014 in)		
	Crank pin and crank journal	Out-of-roundness	0.020 mm (0.0008 in) or less		
		Grinding limit	0.250 mm (0.0098 in)		
	Crank pin outer diameter		STD	51.984 — 52.000 mm (2.0466 — 2.0472 in)	
			0.03 mm (0.0012 in) US	51.954 — 51.970 mm (2.0454 — 2.0461 in)	
			0.05 mm (0.0020 in) US	51.934 — 51.950 mm (2.0446 — 2.0453 in)	
			0.25 mm (0.0098 in) US	51.734 — 51.750 mm (2.0368 — 2.0374 in)	
	Crank journal outer diameter		#1, #3	STD	59.992 — 60.008 mm (2.3619 — 2.3625 in)
				0.03 mm (0.0012 in) US	59.962 — 59.978 mm (2.3607 — 2.3613 in)
				0.05 mm (0.0020 in) US	59.942 — 59.958 mm (2.3599 — 2.3605 in)
				0.25 mm (0.0098 in) US	59.742 — 59.758 mm (2.3520 — 2.3527 in)
			#2, #4, #5	STD	59.992 — 60.008 mm (2.3619 — 2.3625 in)
				0.03 mm (0.0012 in) US	59.962 — 59.978 mm (2.3607 — 2.3613 in)
				0.05 mm (0.0020 in) US	59.942 — 59.958 mm (2.3599 — 2.3605 in)
				0.25 mm (0.0098 in) US	59.742 — 59.758 mm (2.3520 — 2.3527 in)
	Thrust clearance		STD	0.030 — 0.115 mm (0.0012 — 0.0045 in)	
			Limit	0.25 mm (0.0098 in)	
	Oil clearance		#1	STD	0.010 — 0.030 mm (0.0004 — 0.0012 in)
				Limit	0.040 mm (0.0016 in)
			#2	STD	0.010 — 0.030 mm (0.0004 — 0.0012 in)
Limit				0.045 mm (0.0018 in)	
#3			STD	0.010 — 0.030 mm (0.0004 — 0.0012 in)	
			Limit	0.040 mm (0.0016 in)	
#4			STD	0.010 — 0.030 mm (0.0004 — 0.0012 in)	
			Limit	0.045 mm (0.0018 in)	
#5			STD	0.010 — 0.030 mm (0.0004 — 0.0012 in)	
			Limit	0.040 mm (0.0016 in)	
Crankshaft bearing	Crankshaft bearing thickness		#1, #3	STD	1.998 — 2.011 mm (0.0787 — 0.0792 in)
				0.03 mm (0.0012 in) US	2.017 — 2.020 mm (0.0794 — 0.0795 in)
				0.05 mm (0.0020 in) US	2.027 — 2.030 mm (0.0798 — 0.0799 in)
				0.25 mm (0.0098 in) US	2.127 — 2.130 mm (0.0837 — 0.0839 in)
			#2, #4, #5	STD	2.000 — 2.013 mm (0.0787 — 0.0793 in)
				0.03 mm (0.0012 in) US	2.019 — 2.022 mm (0.0795 — 0.0796 in)
				0.05 mm (0.0020 in) US	2.029 — 2.032 mm (0.0799 — 0.0800 in)
				0.25 mm (0.0098 in) US	2.129 — 2.132 mm (0.0838 — 0.0839 in)

GENERAL DESCRIPTION

MECHANICAL

MEMO:

B: COMPONENT

1. TIMING BELT

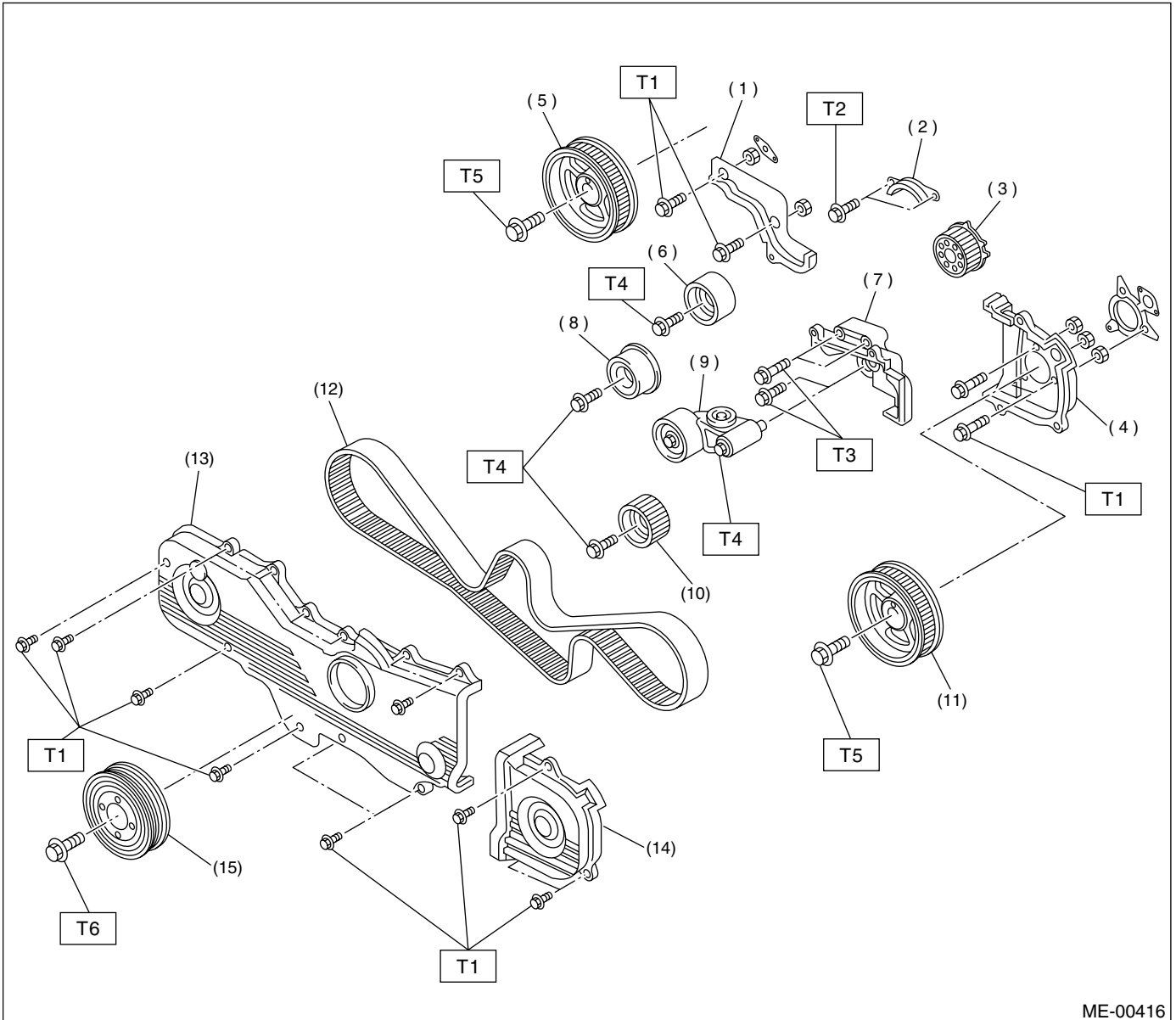

ME-00416

- | | |
|--|------------------------------|
| (1) Belt cover No. 2 (RH) | (10) Belt idler No. 2 |
| (2) Timing belt guide (MT vehicles only) | (11) Camshaft sprocket No. 2 |
| (3) Crankshaft sprocket | (12) Timing belt |
| (4) Belt cover No. 2 (LH) | (13) Front belt cover |
| (5) Camshaft sprocket No. 1 | (14) Belt cover (LH) |
| (6) Belt idler (No. 1) | (15) Crankshaft pulley |
| (7) Tensioner bracket | |
| (8) Belt idler (No. 2) | |
| (9) Automatic belt tension adjuster ASSY | |

Tightening torque: N-m (kgf-m, ft-lb)

T1: 5 (0.5, 3.6)

T2: 10 (1.0, 7.2)

T3: 25 (2.5, 18.1)

T4: 39 (4.0, 28.9)

T5: 78 (8.0, 57.9)

T6: <Ref. to ME(H4SO)-45, INSTALLATION, CRANKSHAFT PULLEY.>

GENERAL DESCRIPTION

MECHANICAL

2. CYLINDER HEAD AND CAMSHAFT

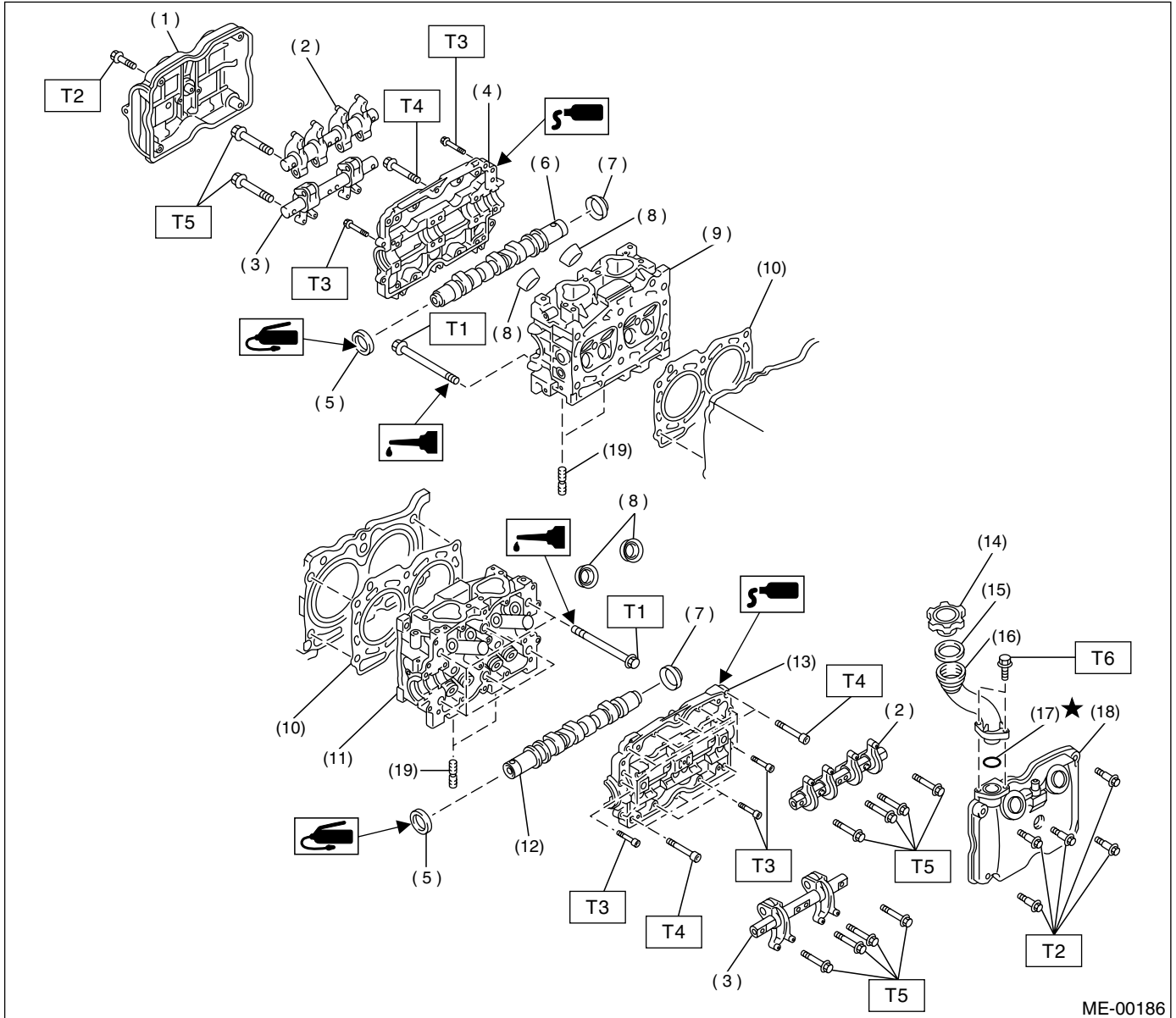

ME-00186

- | | |
|-------------------------------|-------------------------|
| (1) Rocker cover (RH) | (11) Cylinder head (LH) |
| (2) Intake valve rocker ASSY | (12) Camshaft (LH) |
| (3) Exhaust valve rocker ASSY | (13) Camshaft cap (LH) |
| (4) Camshaft cap (RH) | (14) Oil filler cap |
| (5) Oil seal | (15) Gasket |
| (6) Camshaft (RH) | (16) Oil filler duct |
| (7) Plug | (17) O-ring |
| (8) Spark plug pipe gasket | (18) Rocker cover (LH) |
| (9) Cylinder head (RH) | (19) Stud bolt |
| (10) Cylinder head gasket | |

Tightening torque: N-m (kgf-m, ft-lb)

T1: <Ref. to ME(H4SO)-61, CYLINDER HEAD, INSTALLATION, CYLINDER HEAD ASSEMBLY.>

T2: 5 (0.5, 3.6)

T3: 10 (1.0, 7.2)

T4: 18 (1.8, 13.0)

T5: 25 (2.5, 18.1)

T6: 6.4 (0.65, 4.7)

T2: 5 (0.5, 3.6)

T3: 10 (1.0, 7.2)

3. VALVE ROCKER ASSEMBLY

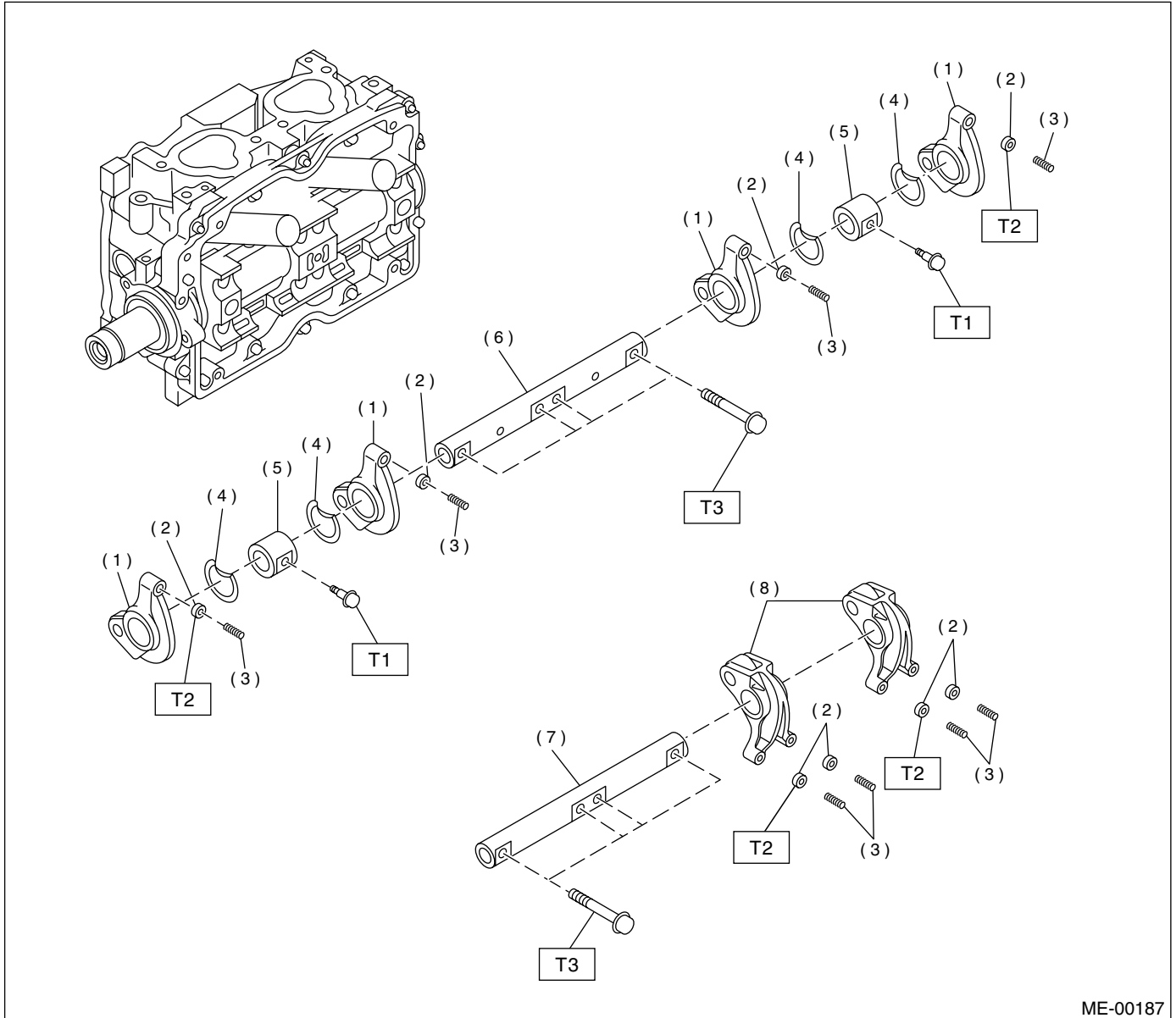

ME-00187

- | | |
|-------------------------------|------------------------------|
| (1) Intake valve rocker arm | (6) Intake rocker shaft |
| (2) Valve rocker nut | (7) Exhaust rocker shaft |
| (3) Valve rocker adjust screw | (8) Exhaust valve rocker arm |
| (4) Spring | |
| (5) Rocker shaft support | |

Tightening torque: N·m (kgf·m, ft·lb)

T1: 5 (0.5, 3.6)

T2: 10 (1.0, 7.2)

T3: 25 (2.5, 18.1)

GENERAL DESCRIPTION

MECHANICAL

4. CYLINDER HEAD AND VALVE ASSEMBLY

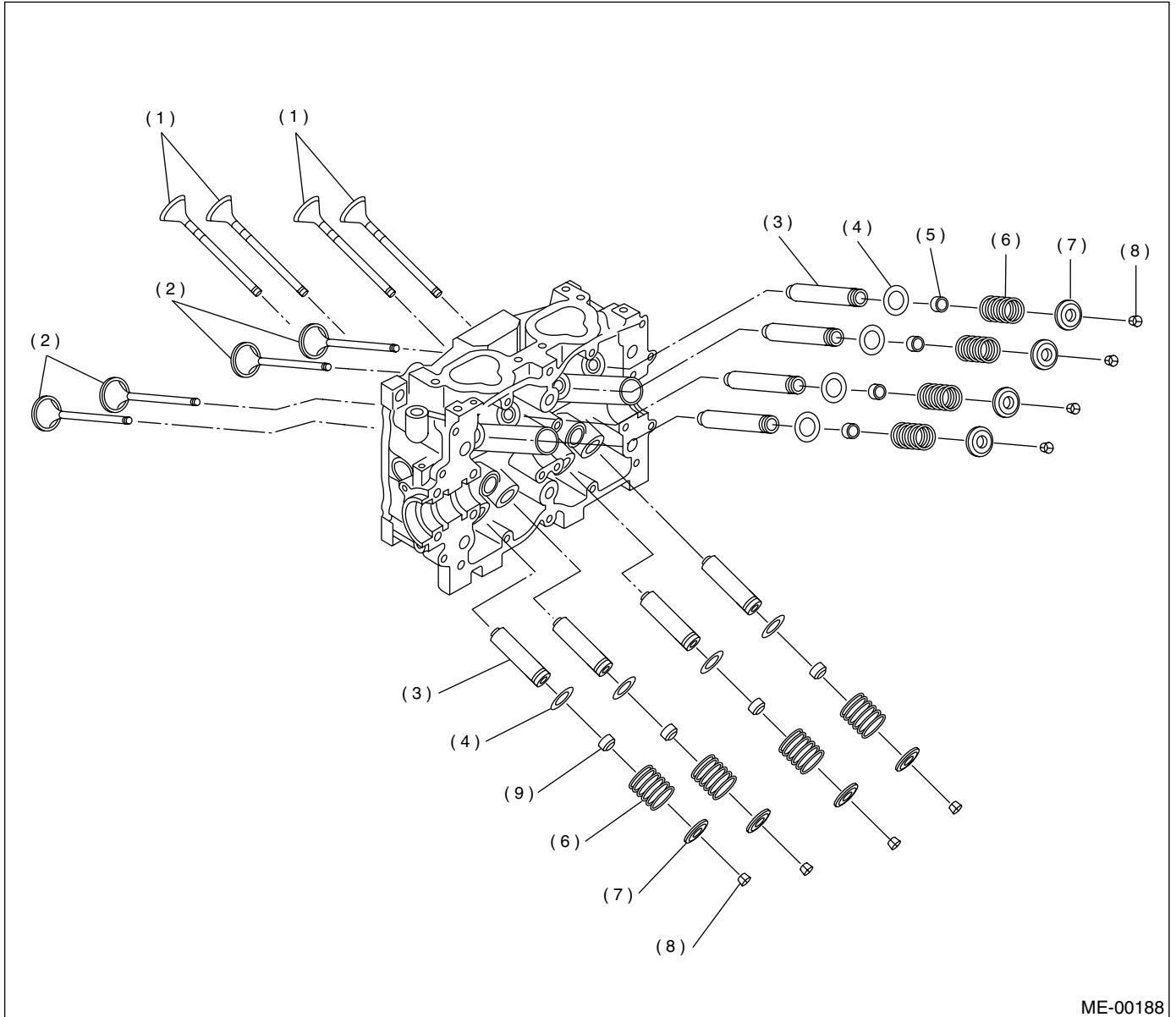

ME-00188

- (1) Exhaust valve
- (2) Intake valve
- (3) Valve guide

- (4) Valve spring seat
- (5) Intake valve oil seal
- (6) Valve spring

- (7) Retainer
- (8) Collet (valve)
- (9) Exhaust valve oil seal

5. CYLINDER BLOCK

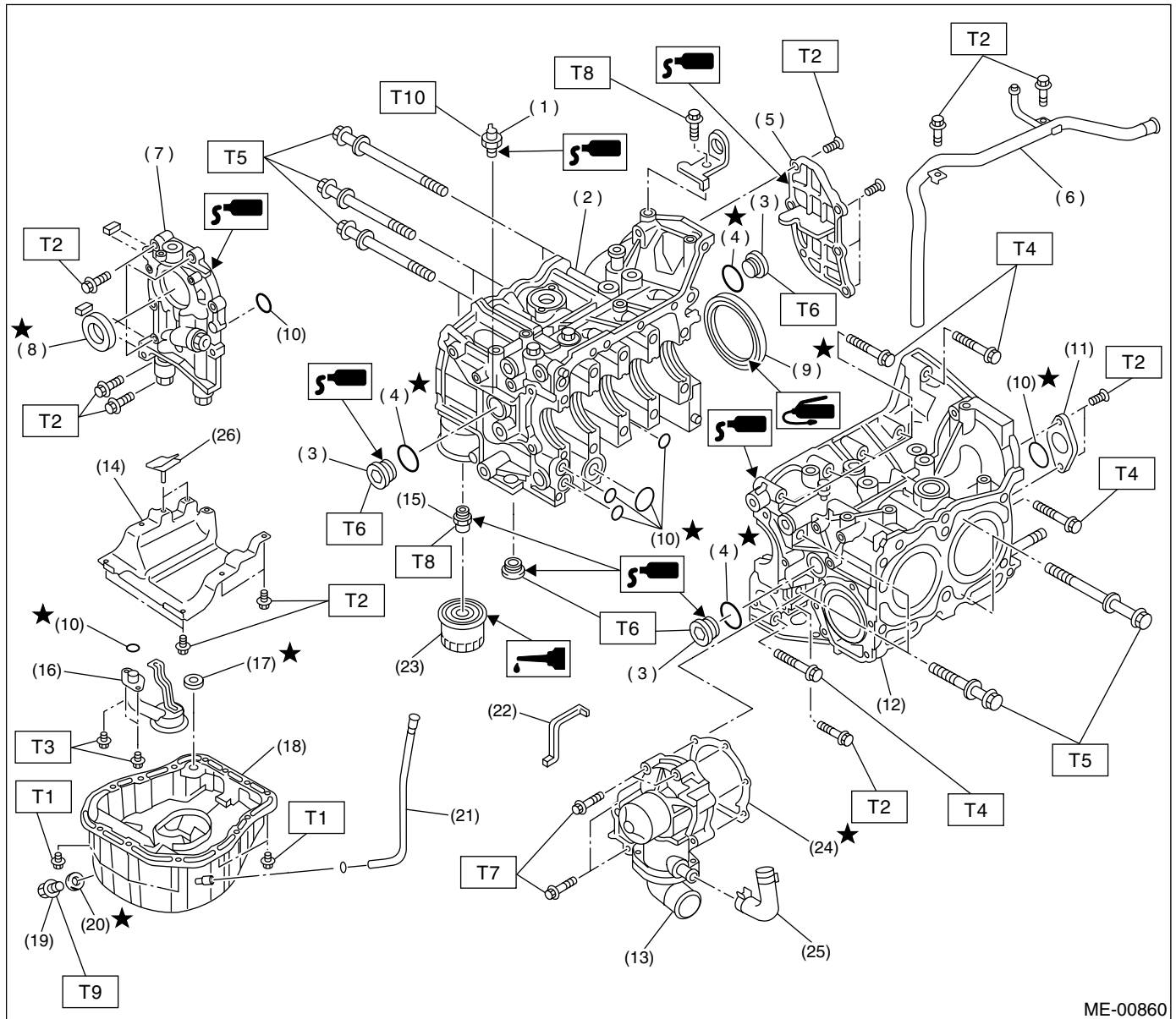

ME-00860

- | | |
|--------------------------|----------------------------|
| (1) Oil pressure switch | (15) Oil filter connector |
| (2) Cylinder block (RH) | (16) Oil strainer |
| (3) Service hole plug | (17) Gasket |
| (4) Gasket | (18) Oil pan |
| (5) Oil separator cover | (19) Drain plug |
| (6) Water by-pass pipe | (20) Metal gasket |
| (7) Oil pump | (21) Oil level gauge guide |
| (8) Front oil seal | (22) Water pump sealing |
| (9) Rear oil seal | (23) Oil filter |
| (10) O-ring | (24) Gasket |
| (11) Service hole cover | (25) Water pump hose |
| (12) Cylinder block (LH) | (26) Seal |
| (13) Water pump | |
| (14) Baffle plate | |

Tightening torque: N·m (kgf·m, ft·lb)

- T1: 5 (0.5, 3.6)**
T2: 6.4 (0.65, 4.7)
T3: 10 (1.0, 7)
T4: 25 (2.5, 18.1)
T5: 47 (4.8, 34.7)
T6: 70 (7.1, 51)
T7: First 12 (1.2, 8.7)
Second 12 (1.2, 8.7)
T8: 45 (4.6, 33)
T9: 44 (4.5, 33)
T10: 25 (2.5, 18.1)

GENERAL DESCRIPTION

MECHANICAL

6. CRANKSHAFT AND PISTON

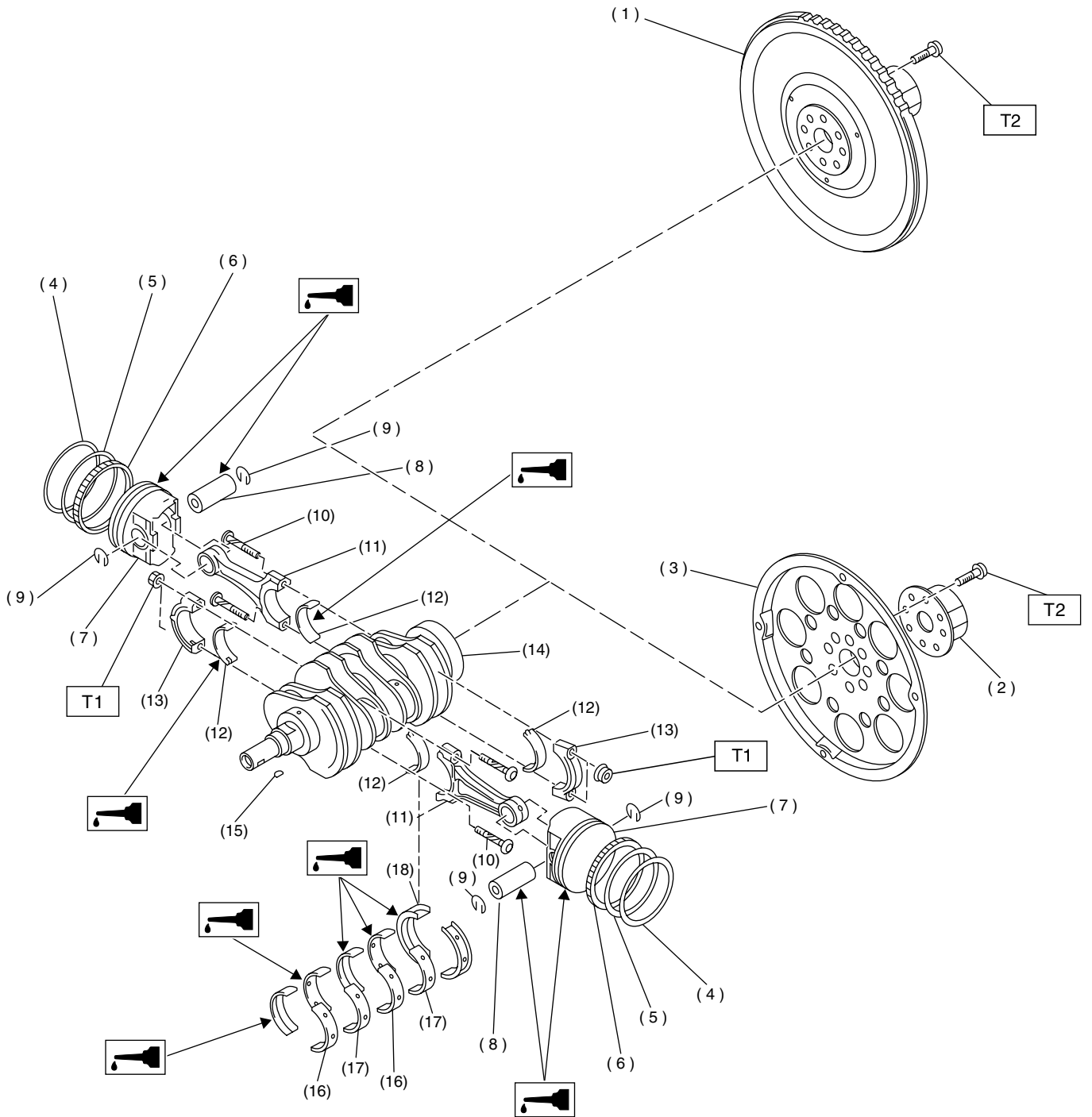

ME-00607

GENERAL DESCRIPTION

MECHANICAL

-
- | | | |
|------------------------|--------------------------------|--------------------------------|
| (1) Flywheel (MT) | (9) Snap ring | (17) Crankshaft bearing #2, #4 |
| (2) Reinforcement (AT) | (10) Connecting rod bolt | (18) Crankshaft bearing #5 |
| (3) Drive plate (AT) | (11) Connecting rod | |
| (4) Top ring | (12) Connecting rod bearing | |
| (5) Second ring | (13) Connecting rod cap | |
| (6) Oil ring | (14) Crankshaft | |
| (7) Piston | (15) Woodruff key | |
| (8) Piston pin | (16) Crankshaft bearing #1, #3 | |

Tightening torque: N·m (kgf-m, ft-lb)

T1: 45 (4.6, 33)

T2: 72 (7.3, 52.8)

GENERAL DESCRIPTION

MECHANICAL

7. ENGINE MOUNTING

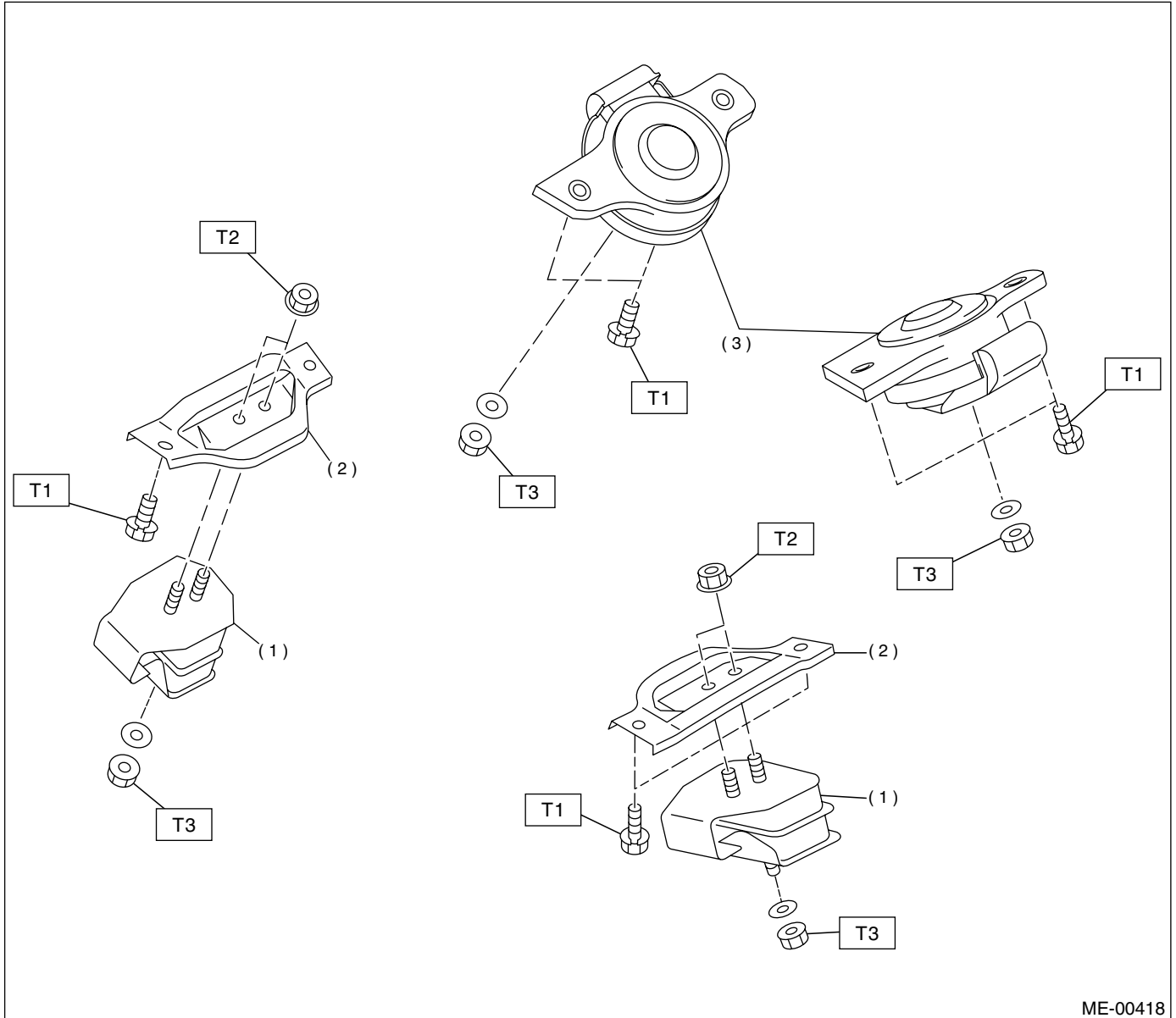

ME-00418

- (1) Front cushion rubber
(BRIGHTON and L AT vehicles)
- (2) Front engine mounting bracket
(BRIGHTON and L AT vehicles)

- (3) Front cushion rubber (Except
BRIGHTON and L AT vehicles)

Tightening : N·m (kgf·m, ft·lb)

T1: 35 (3.6, 25.8)

T2: 42 (4.3, 31.0)

T3: 85 (8.7, 63)

C: CAUTION

- Wear working clothing, including a cap, protective goggles, and protective shoes during operation.
- Remove contamination including dirt and corrosion before removal, installation or disassembly.
- Keep the disassembled parts in order and protect them from dust or dirt.
- Before removal, installation or disassembly, be sure to clarify the failure. Avoid unnecessary removal, installation, disassembly, and replacement.
- Be careful not to burn your hands, because each part in the vehicle is hot after running.
- Be sure to tighten fasteners including bolts and nuts to the specified torque.
- Place shop jacks or safety stands at the specified points.
- Before disconnecting electrical connectors of sensors or units, be sure to disconnect ground cable from battery.
- All parts should be thoroughly cleaned, paying special attention to the engine oil passages, pistons and bearings.

- Rotating parts and sliding parts such as piston, bearing and gear should be coated with oil prior to assembly.
- Be careful not to let oil, grease or coolant contact the timing belt, clutch disc and flywheel.
- All removed parts, if to be reused, should be re-installed in the original positions and directions.
- Bolts, nuts and washers should be replaced with new ones as required.
- Even if necessary inspections have been made in advance, proceed with assembly work while making rechecks.
- Remove or install engine in an area where chain hoists, lifting devices, etc. are available for ready use.
- Be sure not to damage coated surfaces of body panels with tools or stain seats and windows with coolant or oil. Place a cover over fenders, as required, for protection.
- Prior to starting work, prepare the following:
Service tools, clean cloth, containers to catch coolant and oil, wire ropes, chain hoist, transmission jacks, etc.
- Lift-up or lower the vehicle when necessary. Make sure to support the correct positions.

D: PREPARATION TOOL

1. SPECIAL TOOLS

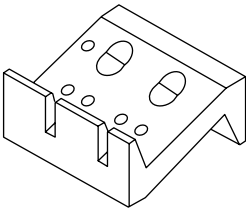
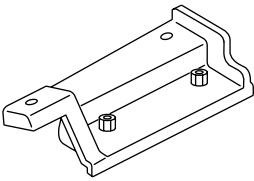
ILLUSTRATION	TOOL NUMBER	DESCRIPTION	REMARKS
 ST-498267800	498267800	CYLINDER HEAD TABLE	<ul style="list-style-type: none"> • Used for replacing valve guides. • Used for removing and installing valve springs.
 ST-498457000	498457000	ENGINE STAND ADAPTER RH	Used with ENGINE STAND (499817000).

GENERAL DESCRIPTION

MECHANICAL

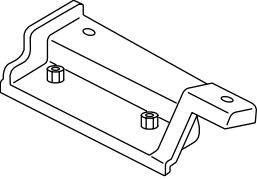
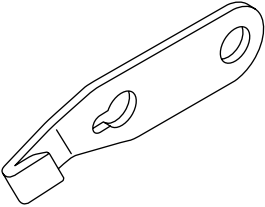
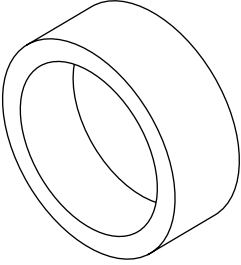
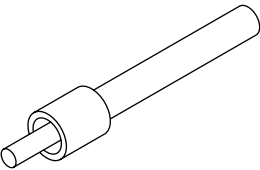
ILLUSTRATION	TOOL NUMBER	DESCRIPTION	REMARKS
 <p style="text-align: center;">ST-498457100</p>	498457100	ENGINE STAND ADAPTER LH	Used with ENGINE STAND (499817000).
 <p style="text-align: center;">ST-498497100</p>	498497100	CRANKSHAFT STOPPER	Used for stopping rotation of flywheel when loosening and tightening crankshaft pulley bolt, etc.
 <p style="text-align: center;">ST-498747300</p>	498747300	PISTON GUIDE	Used for installing piston in cylinder.
 <p style="text-align: center;">ST-498857100</p>	498857100	VALVE OIL SEAL GUIDE	Used for press-fitting of intake and exhaust valve guide oil seals.

GENERAL DESCRIPTION

MECHANICAL

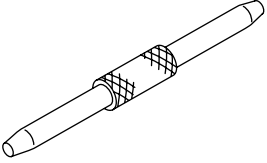
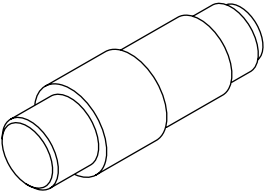
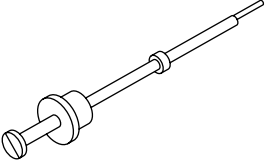
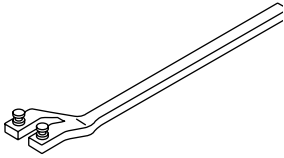
ILLUSTRATION	TOOL NUMBER	DESCRIPTION	REMARKS
 <p style="text-align: center;">ST-499017100</p>	499017100	PISTON PIN GUIDE	Used for installing piston pin, piston and connecting rod.
 <p style="text-align: center;">ST-499037100</p>	499037100	CONNECTING ROD BUSHING REMOVER & INSTALLER	Used for removing and installing connecting rod bushing.
 <p style="text-align: center;">ST-499097700</p>	499097700	PISTON PIN REMOVER ASSY	Used for removing piston pin.
 <p style="text-align: center;">ST18231AAC</p>	18231AA010	CAMSHAFT SPROCKET WRENCH	<ul style="list-style-type: none"> • Used for removing and installing camshaft sprocket. • CAMSHFT SPROCKET WRENCH (499207100) is also can be used.

GENERAL DESCRIPTION

MECHANICAL

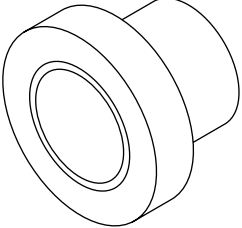
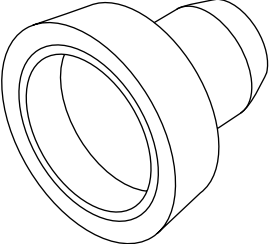
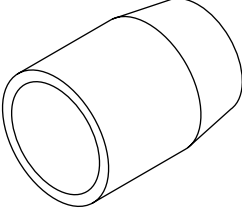
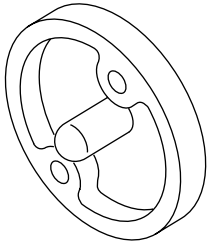
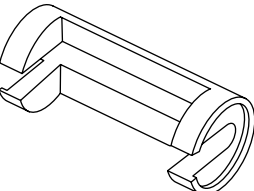
ILLUSTRATION	TOOL NUMBER	DESCRIPTION	REMARKS
 <p style="text-align: center;">ST-499587700</p>	499587700	CAMSHAFT OIL SEAL INSTALLER	Used for installing cylinder head plug.
 <p style="text-align: center;">ST-499587200</p>	499587200	CRANKSHAFT OIL SEAL INSTALLER	<ul style="list-style-type: none"> • Used for installing crankshaft oil seal. • Used with CRANKSHAFT OIL SEAL GUIDE (499597100).
 <p style="text-align: center;">ST-499597000</p>	499597000	OIL SEAL GUIDE	<ul style="list-style-type: none"> • Used for installing camshaft oil seal. • Used with CAMSHAFT OIL SEAL INSTALLER (499587500).
 <p style="text-align: center;">ST-499597100</p>	499597100	CRANKSHAFT OIL SEAL GUIDE	<ul style="list-style-type: none"> • Used for installing crankshaft oil seal. • Used with CRANKSHAFT OIL SEAL INSTALLER (499587200).
 <p style="text-align: center;">ST-499718000</p>	499718000	VALVE SPRING REMOVER	Used for removing and installing valve spring.

GENERAL DESCRIPTION

MECHANICAL

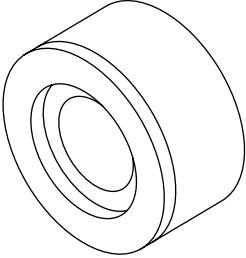
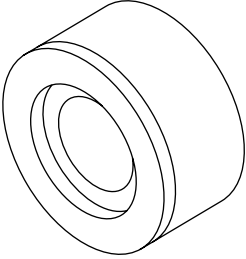
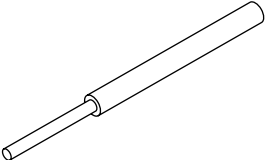
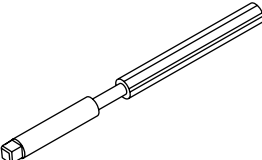
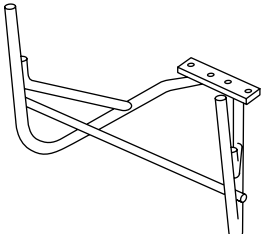
ILLUSTRATION	TOOL NUMBER	DESCRIPTION	REMARKS
 <p style="text-align: center;">ST-499767700</p>	<p style="text-align: center;">499767700 (Intake side)</p>	<p style="text-align: center;">VALVE GUIDE ADJUSTER</p>	<p>Used for installing valve guides.</p>
 <p style="text-align: center;">ST-499767800</p>	<p style="text-align: center;">499767800 (Exhaust side)</p>	<p style="text-align: center;">VALVE GUIDE ADJUSTER</p>	<p>Used for installing valve guides.</p>
 <p style="text-align: center;">ST-499767200</p>	<p style="text-align: center;">499767200</p>	<p style="text-align: center;">VALVE GUIDE REMOVER</p>	<p>Used for removing valve guides.</p>
 <p style="text-align: center;">ST-499767400</p>	<p style="text-align: center;">499767400</p>	<p style="text-align: center;">VALVE GUIDE REAMER</p>	<p>Used for reaming valve guides.</p>
 <p style="text-align: center;">ST-499817100</p>	<p style="text-align: center;">499817100</p>	<p style="text-align: center;">ENGINE STAND</p>	<ul style="list-style-type: none"> • Stand used for engine disassembly and assembly. • Used with ENGINE STAND ADAPTER RH (498457000) & LH (498457100).

GENERAL DESCRIPTION

MECHANICAL

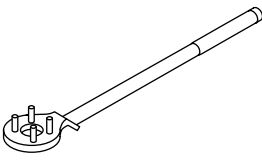
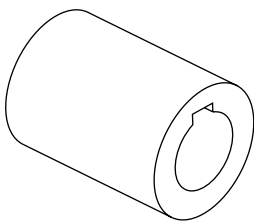
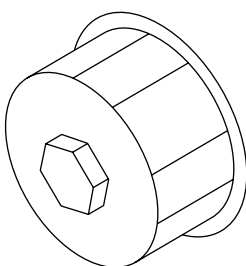
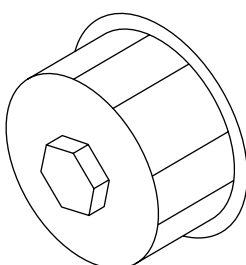
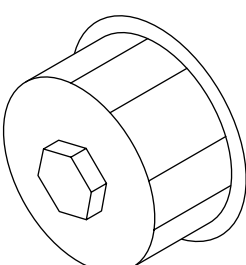
ILLUSTRATION	TOOL NUMBER	DESCRIPTION	REMARKS
 <p style="text-align: center;">ST-499977100</p>	499977100	CRANK PULLEY WRENCH	Used for stopping rotation of crankshaft pulley when loosening and tightening crankshaft pulley bolts.
 <p style="text-align: center;">ST-499987500</p>	499987500	CRANKSHAFT SOCKET	Used for rotating crankshaft.
 <p style="text-align: center;">ST-498547000</p>	498547000 (Outer diameter 80 mm (3.15 in) for oil filter)	OIL FILTER WRENCH	Used for removing and installing oil filter.
 <p style="text-align: center;">ST18332AA000</p>	18332AA000 (Outer diameter 68 mm (2.68 in) for oil filter)	OIL FILTER WRENCH	Used for removing and installing oil filter.
 <p style="text-align: center;">ST18332AA010</p>	18332AA010 (Outer diameter 65 mm (2.56 in) for oil filter)	OIL FILTER WRENCH	Used for removing and installing oil filter.

GENERAL DESCRIPTION

MECHANICAL

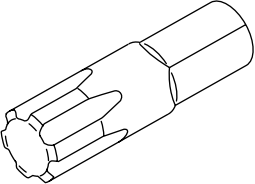
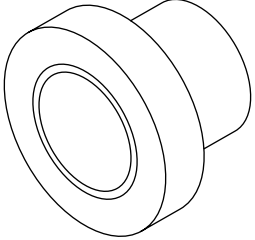
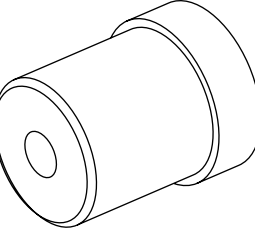
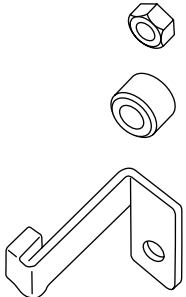
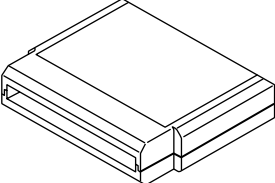
ILLUSTRATION	TOOL NUMBER	DESCRIPTION	REMARKS
 <p style="text-align: center;">ST-499497000</p>	499497000	TORX PLUS	Used for removing and installing camshaft cap.
 <p style="text-align: center;">ST-499587500</p>	499587500	OIL SEAL INSTALLER	Used for installing front camshaft oil seal.
 <p style="text-align: center;">ST-499587100</p>	499587100	OIL SEAL INSTALLER	Used for installing oil pump oil seal.
 <p style="text-align: center;">ST-498277200</p>	498277200	STOPPER SET	Used for installing automatic transmission assembly to engine.
 <p style="text-align: center;">ST24082AA230</p>	24082AA230	CARTRIDGE	Troubleshooting for electrical systems.

GENERAL DESCRIPTION

MECHANICAL

ILLUSTRATION	TOOL NUMBER	DESCRIPTION	REMARKS
 ST22771AA030	22771AA030	SELECT MONI-TOR KIT	Troubleshooting for electrical systems.

2. GENERAL PURPOSE TOOLS

TOOL NAME	REMARKS
Compression gauge	Used for measuring compression.
Tachometer (Secondary pick-up type)	Used for measuring idle speed.
Timing light	Used for measuring ignition timing.

E: PROCEDURE

It is possible to conduct the following service procedures with engine on the vehicle, however, the procedures described in this section are based on the condition that the engine is removed from the vehicle.

- V-belt
- Timing Belt
- Valve Rocker Assembly
- Camshaft
- Cylinder Head

2. Compression

A: INSPECTION

CAUTION:

After warming-up, engine becomes very hot. Be careful not to burn yourself during measurement.

- 1) After warming-up the engine, turn ignition switch to OFF.
- 2) Make sure that the battery is fully charged.
- 3) Release fuel pressure. <Ref. to FU(H4SO)-48, RELEASING OF FUEL PRESSURE, OPERATION, Fuel.>
- 4) Remove all the spark plugs. <Ref. to IG(H4SO)-4, REMOVAL, Spark Plug.>
- 5) Fully open throttle valve.
- 6) Check the starter motor for suitable performance and operation.
- 7) Hold the compression gauge tight against the spark plug hole.

NOTE:

When using a screw-in type compression gauge, the screw (put into cylinder head spark plug hole) should be less than 18 mm (0.71 in) long.

- 8) Crank the engine by means of the starter motor, and read the maximum value on the gauge when the pointer is steady.

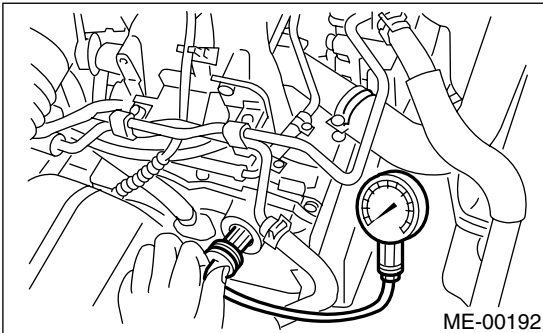

- 9) Perform at least two measurements per cylinder, and make sure that the values are correct.

Compression (350 rpm and fully open throttle):

Standard;

1,275 kPa (13.0 kg/cm², 185 psi)

Limit;

1,079 kPa (11.0 kg/cm², 156 psi)

Difference between cylinders;

49 kPa (0.5 kg/cm², 7 psi), or less

3. Idle Speed

A: INSPECTION

- 1) Before checking idle speed, check the following:
 - (1) Ensure that air cleaner element is free from clogging, ignition timing is correct, spark plugs are in good condition, and that hoses are connected properly.
 - (2) Ensure that malfunction indicator light (CHECK ENGINE light) does not illuminate.
- 2) Warm-up the engine.
- 3) Stop the engine, and turn ignition switch to OFF.
- 4) When using SUBARU SELECT MONITOR <Ref. to ME(H4SO)-15, SPECIAL TOOLS, PREPARATION TOOL, General Description.>
 - (1) Insert the cartridge to SUBARU SELECT MONITOR.
 - (2) Connect SUBARU SELECT MONITOR to the data link connector.

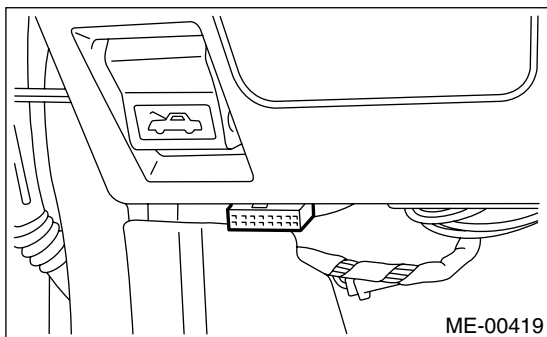

- (3) Turn ignition switch to ON, and SUBARU SELECT MONITOR switch to ON.
 - (4) Select {2. Each System Check} in Main Menu.
 - (5) Select {Engine Control System} in Selection Menu.
 - (6) Select {1. Current Data Display & Save} in Engine Control System Diagnosis.
 - (7) Select {1.12 Data Display} in Data Display Menu.
 - (8) Start the engine, and read engine idle speed.
- 5) When using tachometer (Secondary pick-up type).
 - (1) Attach the pick-up clip to No. 1 cylinder spark plug cord.

- (2) Start the engine, and read engine idle speed.

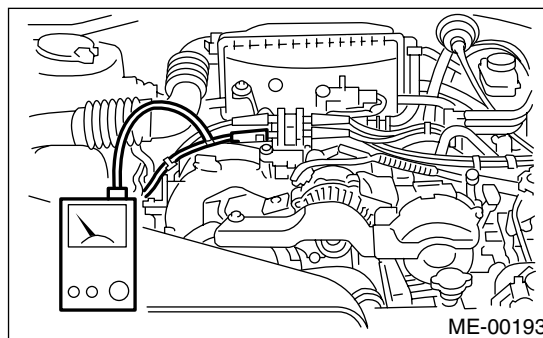

NOTE:

- When using the OBD-II general scan tool, carefully read its operation manual.
- This ignition system provides simultaneous ignition for #1 and #2 plugs. It must be noted that some tachometers may register twice that of actual engine speed.

6) Check idle speed when unloaded. (With headlights, heater fan, rear defroster, radiator fan, air conditioning, etc. OFF)

Idle speed (No load and gears in neutral (MT), or N or P (AT) position):

MT vehicle: 650±100 rpm

AT vehicle: 700±100 rpm

7) Check idle speed when loaded. (Turn air conditioning switch to “ON” and operate compressor for at least one minute before measurement.)

Idle speed [A/C “ON”, no load and gears in neutral (MT) or N or P (AT) position]:

850±100 rpm

NOTE:

The idle speed is adjusted automatically and manual adjusting cannot be performed. If idle speed is out of specifications, refer to General On-board Diagnosis Table under “Engine Control System”. <Ref. to EN(H4SO)-2, Basic Diagnostic Procedure.>

4. Ignition Timing

A: INSPECTION

CAUTION:

After warming-up, engine becomes very hot. Be careful not to burn yourself during measurement.

- 1) Warm-up the engine.
- 2) To check the ignition timing, connect a timing light to #1 cylinder spark plug cord, and illuminate the timing mark with the timing light.
- 3) Start the engine at idle speed and check the ignition timing.

Ignition timing [BTDC/rpm]:

MT vehicle: $10^{\circ} \pm 8^{\circ} / 650$

AT vehicle: $15^{\circ} \pm 8^{\circ} / 700$

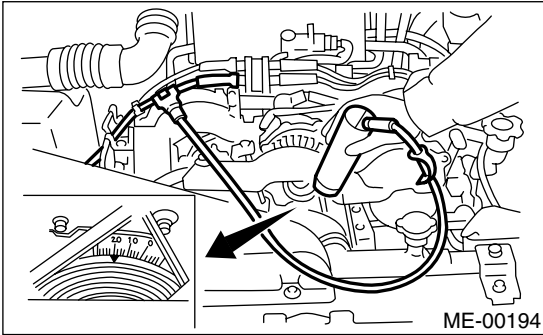

If the timing is not correct, check the ignition control system.

Refer to Engine Control System. <Ref. to EN(H4SO)-2, Basic Diagnostic Procedure.>

5. Intake Manifold Vacuum

A: INSPECTION

- 1) Warm-up the engine.
- 2) Disconnect the brake vacuum hose and install the vacuum gauge to the hose fitting on the manifold.
- 3) Keep the engine at the idle speed and read the vacuum gauge indication.

By observing the gauge needle movement, the internal condition of the engine can be diagnosed as described below.

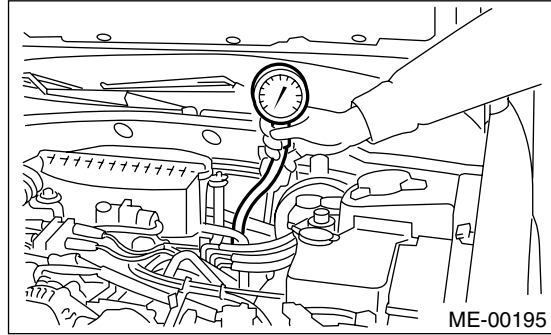

ME-00195

Vacuum pressure (at idling, A/C "OFF"):
Less than -60.0 kPa (-450 mmHg, -17.72 inHg)

Diagnosis of engine condition by measurement of manifold vacuum	
Vacuum gauge indication	Possible engine condition
1. Needle is steady but lower than normal position. This tendency becomes more evident as engine temperature rises.	Leakage around intake manifold gasket or disconnection or damaged vacuum hose
2. When engine speed is reduced slowly from higher speed, needle stops temporarily when it is lowering or becomes steady above normal position.	Back pressure too high, or exhaust system clogged
3. Needle intermittently drops to position lower than normal position.	Leakage around cylinder
4. Needle drops suddenly and intermittently from normal position.	Sticky valves
5. When engine speed is gradually increased, needle begins to vibrate rapidly at certain speed, and then vibration increases as engine speed increases.	Weakend stiffness or broken valve springs
6. Needle vibrates above and below normal position in narrow range.	Defective ignition system or idle adjustment

6. Engine Oil Pressure

A: INSPECTION

1) Disconnect battery ground cable.

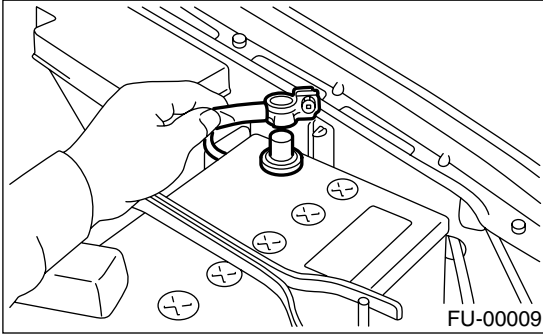

2) Remove generator from bracket. <Ref. to SC(H4SO)-15, REMOVAL, Generator.>

3) Disconnect connector from oil pressure switch.

4) Remove oil pressure switch from engine cylinder block. <Ref. to LU(H4SO)-18, REMOVAL, Oil Pressure Switch.>

5) Connect oil pressure gauge hose to cylinder block.

6) Connect battery ground cable.

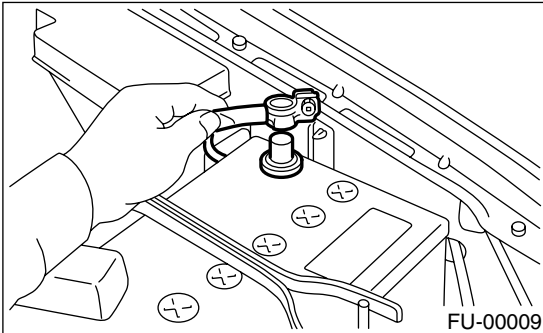

7) Start the engine, and measure oil pressure.

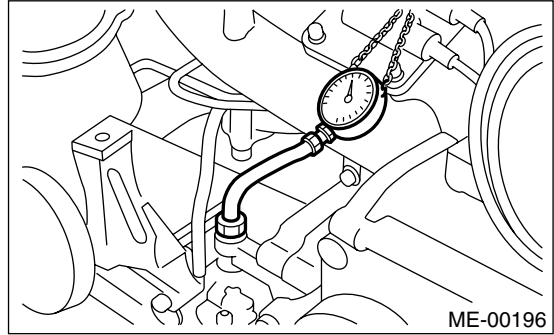

Oil pressure:

88 kPa (0.9 kg/cm², 13 psi) or more at 800 rpm

294 kPa (3.0 kg/cm², 43 psi) or more at 5,000 rpm

CAUTION:

- If oil pressure is out of specification, check oil pump, oil filter and lubrication line. <Ref. to LU(H4SO)-20, INSPECTION, Engine Lubrication System Trouble in General.>

- If oil pressure warning light is turned ON and oil pressure is in specification, replace oil pressure switch. <Ref. to LU(H4SO)-20, INSPECTION, Engine Lubrication System Trouble in General.>

NOTE:

The specified data is based on an engine oil temperature of 80°C (176°F).

8) After measuring oil pressure, install oil pressure switch. <Ref. to LU(H4SO)-18, INSTALLATION, Oil Pressure Switch.>

Tightening torque:

25 N·m (2.5 kgf-m, 18.1 ft-lb)

9) Install generator and V-belt in the reverse order of removal, and adjust the V-belt deflection. <Ref. to ME(H4SO)-43, INSTALLATION, V-belt.>

7. Fuel Pressure

A: INSPECTION

WARNING:

Before removing fuel pressure gauge, release fuel pressure.

NOTE:

If out of specification, check or replace pressure regulator and pressure regulator vacuum hose.

1) Release fuel pressure. <Ref. to FU(H4SO)-48, RELEASING OF FUEL PRESSURE, OPERATION, Fuel.>

2) Open fuel flap lid, and remove fuel filler cap.

3) Disconnect fuel delivery hoses from fuel filter, and connect fuel pressure gauge.

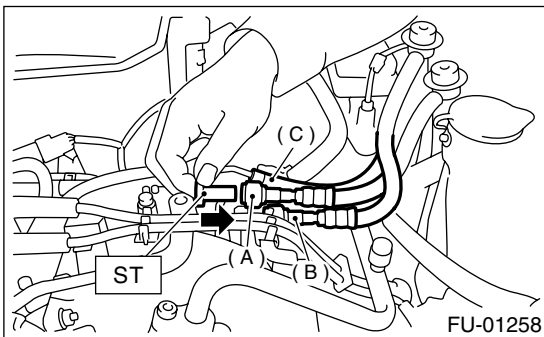

- (A) Fuel delivery hose
- (B) Return hose
- (C) Evaporation hose

4) Connect connector of fuel pump relay.

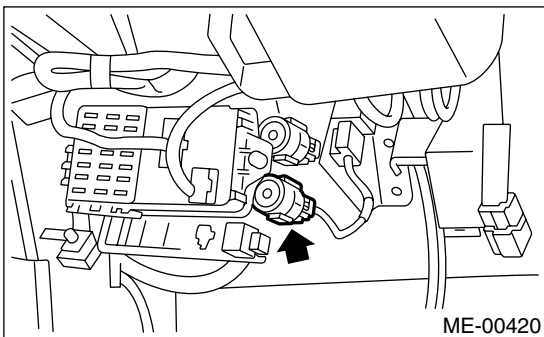

5) Start the engine.

6) Measure fuel pressure while disconnecting pressure regulator vacuum hose from intake manifold.

Fuel pressure:

Standard; 284 — 314 kPa (2.9 — 3.2 kg/cm², 41 — 46 psi)

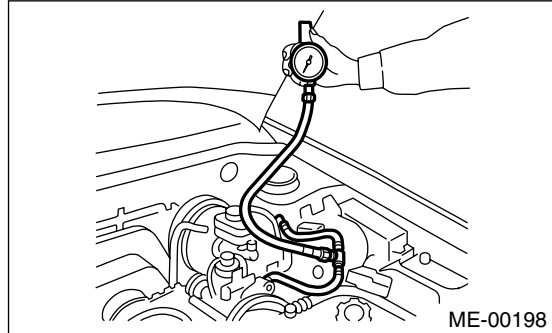

7) After connecting pressure regulator vacuum hose, measure fuel pressure.

Fuel pressure:

Standard; 206 — 235 kPa (2.1 — 2.4 kg/cm², 30 — 34 psi)

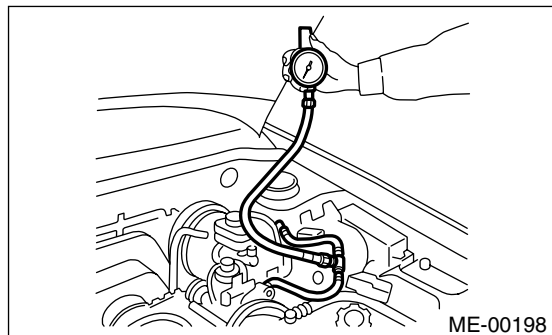

NOTE:

The fuel pressure gauge registers 10 to 20 kPa (0.1 to 0.2 kg/cm², 1 to 3 psi) higher than standard values during high-altitude operations.

VALVE CLEARANCE

MECHANICAL

8. Valve Clearance

A: INSPECTION

CAUTION:

Inspection and adjustment of valve clearance should be performed while engine is cold.

- 1) Set the vehicle onto the lift.
- 2) Lift-up the vehicle.
- 3) Remove under cover.

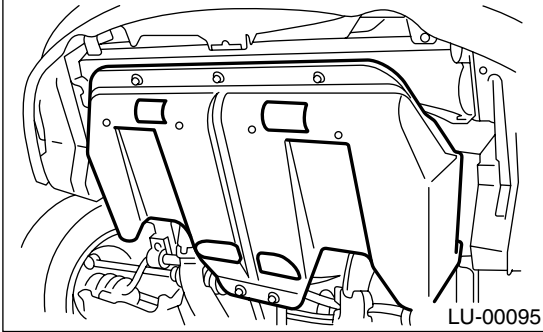

- 4) Lower the vehicle.
- 5) Disconnect battery ground cable.

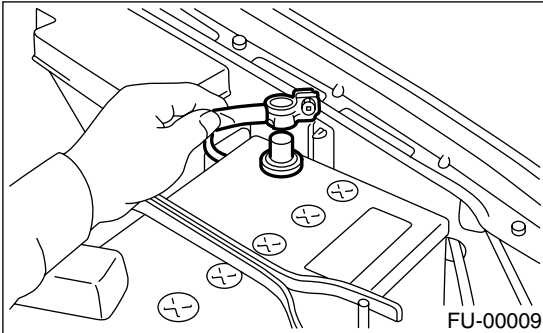

- 6) Remove timing belt cover (LH).

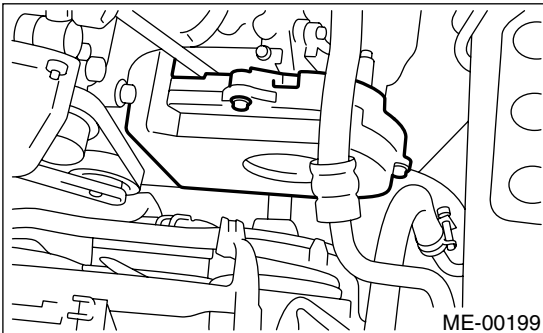

- 7) When inspecting #1 and #3 cylinders (Except U5);

- (1) Remove air intake duct as a unit.

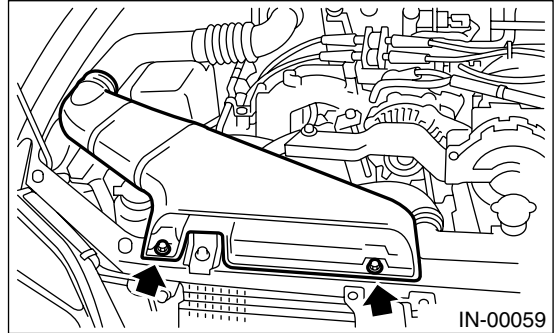

- (2) Remove bolt, and then remove resonator chamber.

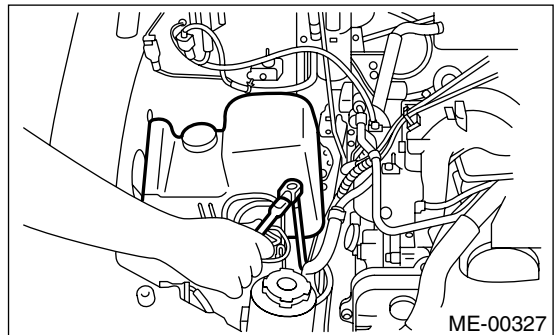

- (3) Disconnect spark plug cords from spark plugs (#1 and #3 cylinders).

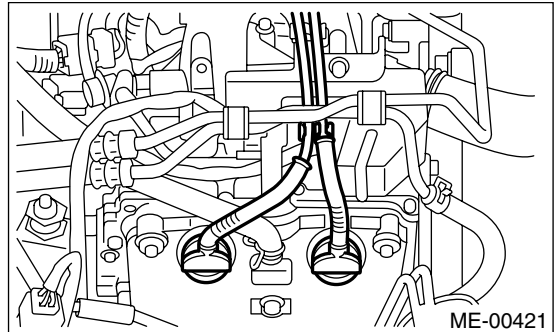

- (4) Disconnect PCV hose from rocker cover (RH).

- (5) Remove bolts, then remove rocker cover (RH).

- 8) When inspecting #2 and #4 cylinders;
 (1) Disconnect battery cables, and then remove battery and battery carrier.

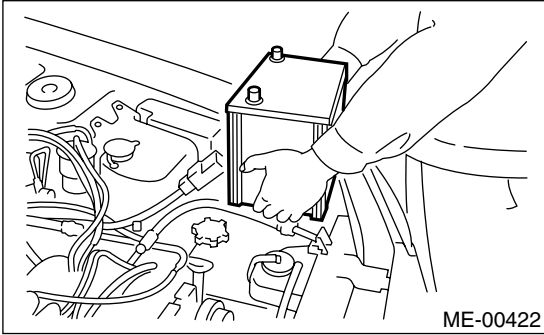

- (2) Remove the two bolts which hold washer tank.

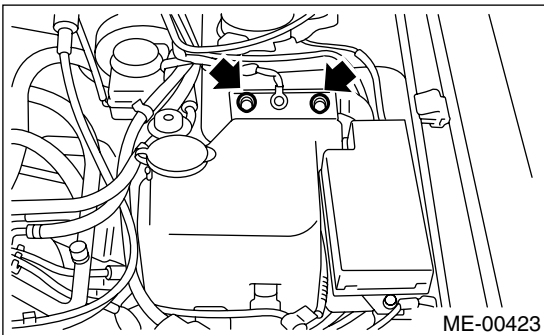

- (3) Disconnect washer motor connectors.

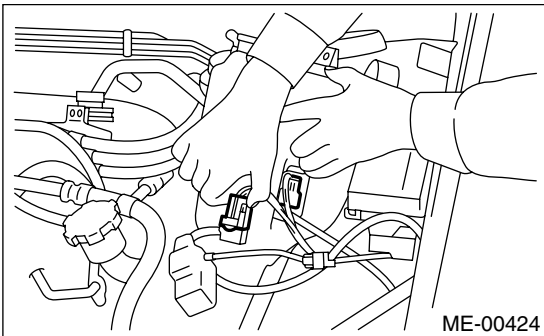

- (4) Move washer tank to forward.

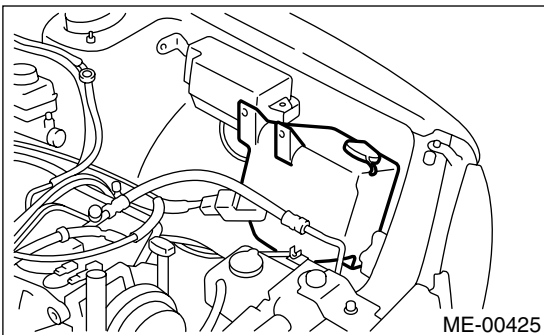

- (5) Disconnect spark plug cords from spark plugs (#2 and #4 cylinders).

- (6) Disconnect PCV hose from rocker cover (LH).

- (7) Remove bolts, then remove rocker cover (LH).

- 9) Set #1 cylinder piston to top dead center of compression stroke by rotating crankshaft pulley clockwise.

NOTE:

When arrow mark (A) on camshaft sprocket (LH) comes exactly to the top, #1 cylinder piston is brought to the top dead center of compression stroke.

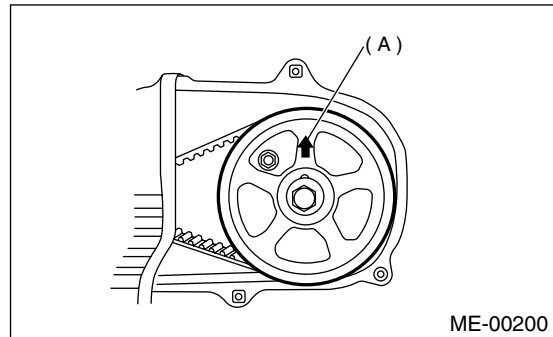

- 10) Measure #1 cylinder valve clearance by using thickness gauge.

NOTE:

- Insert the thickness gauge in as horizontal a direction as possible with respect to the valve stem end face.
- Measure exhaust valve clearances while lifting-up the vehicle.

Valve clearance:

Intake;

0.20 ± 0.02 mm (0.0079 ± 0.0008 in)

Exhaust;

0.25 ± 0.02 mm (0.0098 ± 0.0008 in)

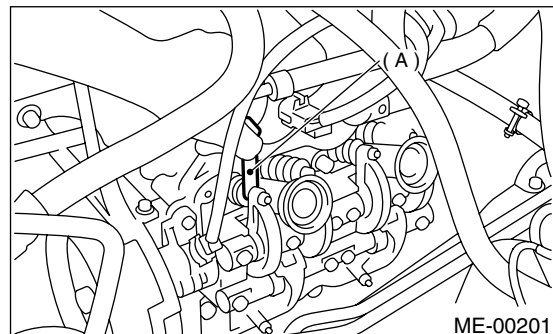

(A) Thickness gauge

VALVE CLEARANCE

MECHANICAL

11) If necessary, adjust the valve clearance. <Ref. to ME(H4SO)-32, ADJUSTMENT, Valve Clearance.>

12) Similar to measurement procedures used for #1 cylinder, measure #2, #3 and #4 cylinder valve clearances.

NOTE:

- Be sure to set cylinder pistons to their respective top dead centers on compression stroke before measuring valve clearances.
- To set #3, #2 and #4 cylinder pistons to their top dead centers on compression stroke, turn crankshaft pulley clockwise 90° at a time starting with arrow mark on left-hand camshaft sprocket facing up.

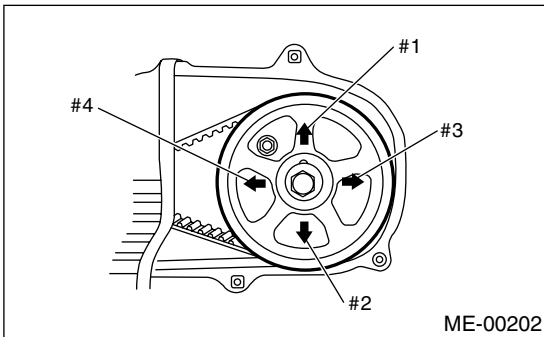

13) After inspection, install the related parts in the reverse order of removal.

Tightening torque:

Resonator chamber;

33 N·m (3.4 kgf-m, 24.6 ft-lb)

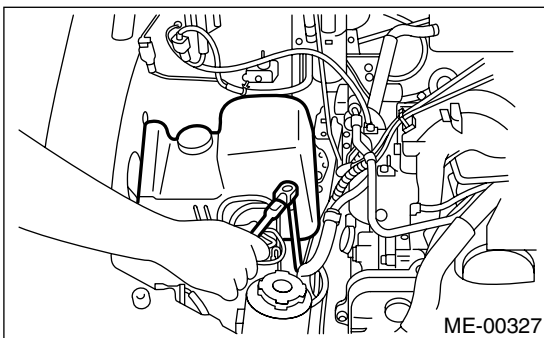

B: ADJUSTMENT

NOTE:

Adjustment of valve clearance should be performed while engine is cold.

1) Set #1 cylinder piston to top dead center of compression stroke by rotating crankshaft pulley clockwise.

NOTE:

When arrow mark (A) on camshaft sprocket (LH) comes exactly to the top, #1 cylinder piston is brought to the top dead center of compression stroke.

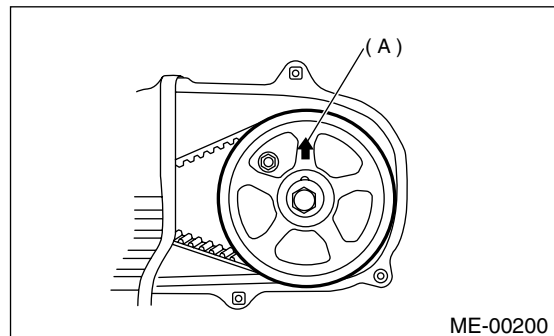

2) Adjust the #1 cylinder valve clearance.

- (1) Loosen the valve rocker nut and screw.
- (2) Place suitable thickness gauge.
- (3) While noting valve clearance, tighten valve rocker adjust screw.
- (4) When specified valve clearance is obtained, tighten valve rocker nut.

Tightening torque:

10 N·m (1.0 kgf-m, 7.2 ft-lb)

NOTE:

- Insert the thickness gauge in as horizontal a direction as possible with respect to the valve stem end face.
- Adjust exhaust valve clearances while lifting-up the vehicle.

Valve clearance:

Intake;

0.20 ± 0.02 mm (0.0079 ± 0.0008 in)

Exhaust;

0.25 ± 0.02 mm (0.0098 ± 0.0008 in)

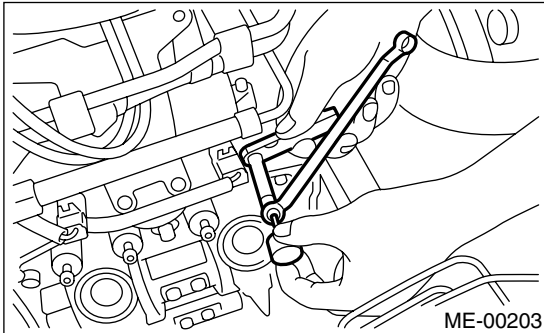

- 3) Ensure that valve clearances are within specifications.
- 4) Turn crankshaft two complete rotations until #1 cylinder piston is again set to top dead center on compression stroke.
- 5) Ensure that valve clearances are within specifications. If necessary, readjust valve clearances.
- 6) Similar to adjustment procedures used for #1 cylinder, adjust #2, #3 and #4 cylinder valve clearances.

NOTE:

- Be sure to set cylinder pistons to their respective top dead centers on compression stroke before adjusting valve clearances.
- To set #3, #2 and #4 cylinder pistons to their top dead centers on compression stroke, turn crankshaft pulley clockwise 90° at a time starting with arrow mark on left-hand camshaft sprocket facing up.

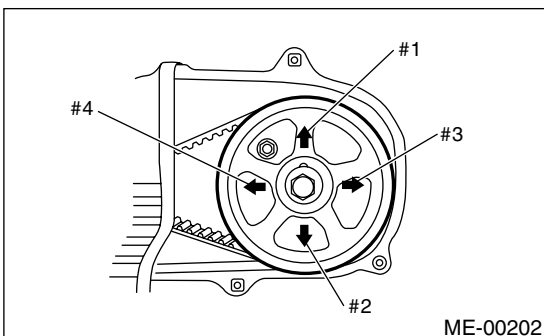

ENGINE ASSEMBLY

MECHANICAL

9. Engine Assembly

A: REMOVAL

- 1) Set the vehicle on lift arms.
- 2) Open front hood fully and support with stay.
- 3) Raise rear seat, and turn floor mat up.
- 4) Release fuel pressure. <Ref. to FU(H4SO)-48, RELEASING OF FUEL PRESSURE, OPERATION, Fuel.>
- 5) Remove filler cap.
- 6) Collect refrigerant, and remove pressure hoses. (With A/C) <Ref. to AC-38, REMOVAL, Flexible Hose.>
- 7) Disconnect battery ground cable.

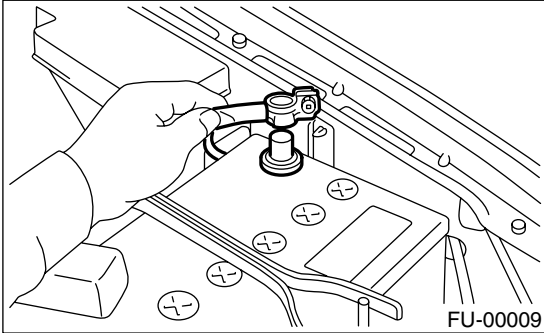

- 8) Remove air intake duct and air cleaner case. <Ref. to IN(H4SO)-6, REMOVAL, Air Intake Duct.> and <Ref. to IN(H4SO)-5, REMOVAL, Air Cleaner Case.>
- 9) Remove under cover.
- 10) Remove radiator from vehicle. <Ref. to CO(H4SO)-20, REMOVAL, Radiator.>
- 11) Remove ATF cooler pipe from body. <Ref. to 4AT-82, REMOVAL, ATF Cooler Pipe and Hose.>
- 12) Remove air cleaner case stay.

• MT model

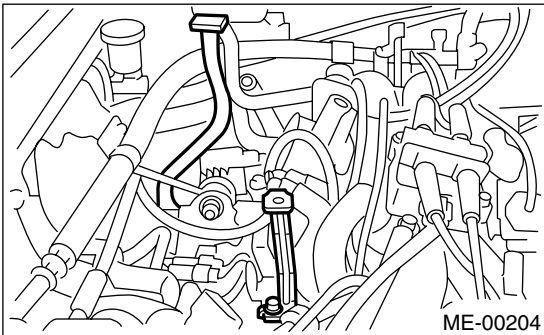

• AT model

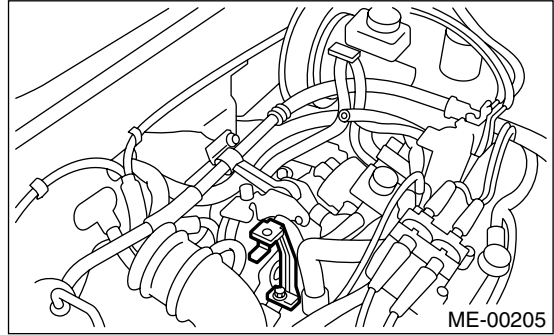

- 13) Disconnect the following connectors and cables.

(1) Engine ground terminal

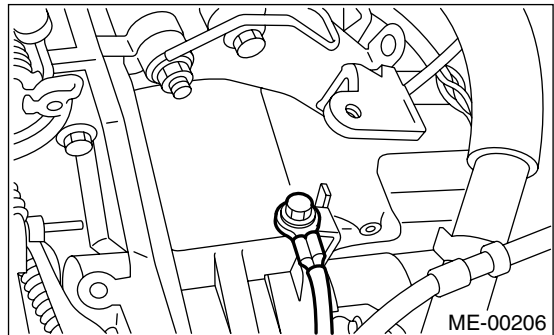

(2) Engine harness connectors

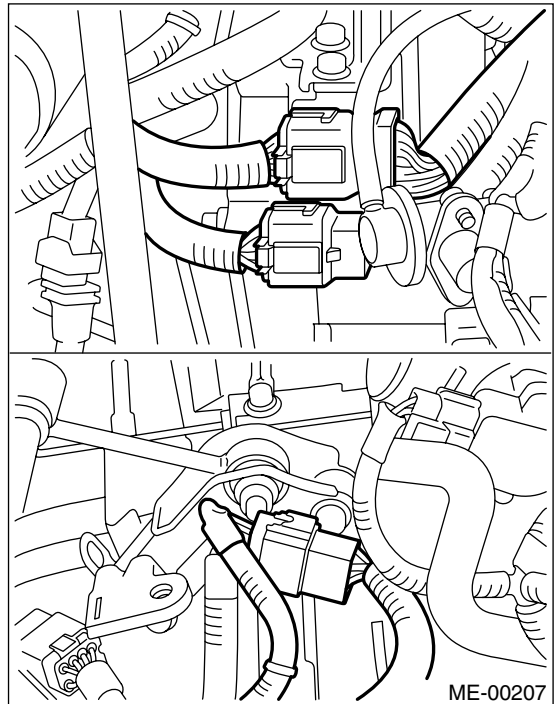

(3) Alternator connector, terminal and A/C compressor connector

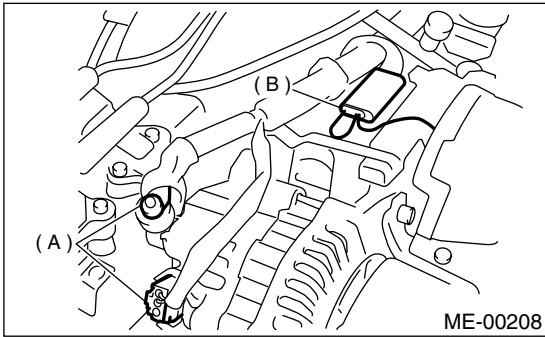

- (A) Alternator connector and terminal
- (B) A/C compressor connector

(4) Accelerator cable and cruise control cable

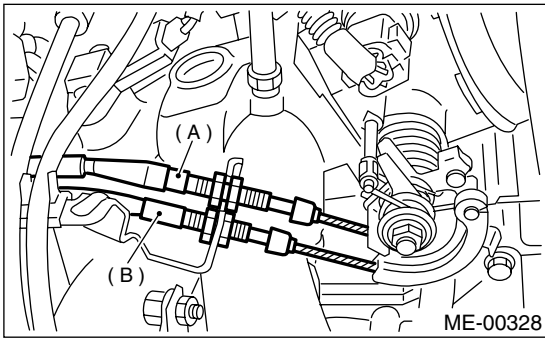

- (A) Accelerator cable
- (B) Cruise control cable

(5) Pressure switch

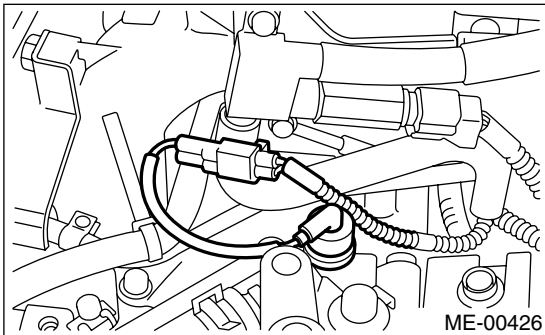

14) Disconnect the following hoses.

(1) Brake booster vacuum hose

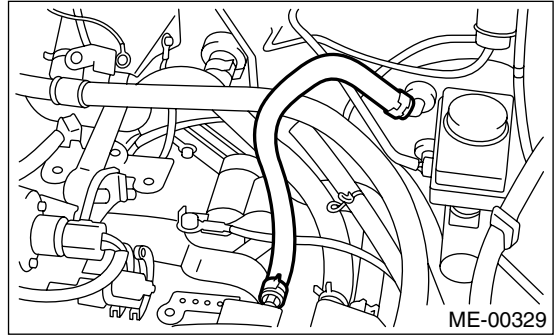

(2) Heater inlet/outlet hose

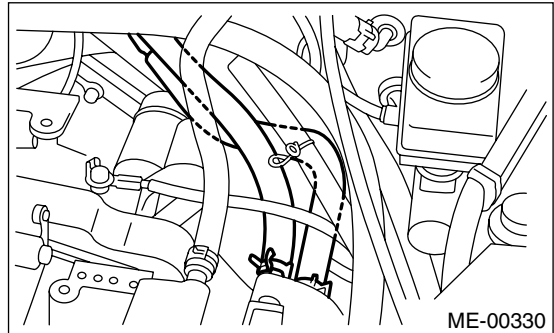

15) Remove power steering pump from bracket.
(1) Remove resonator chamber (Except U5).

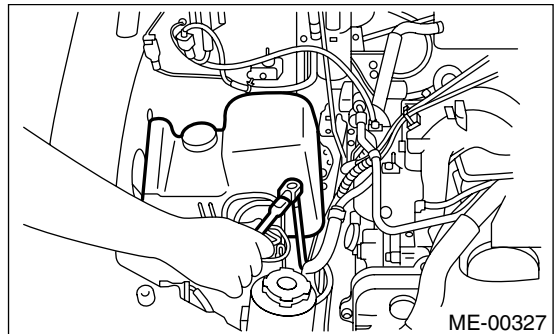

(2) Loosen lock bolt and slider bolt, and remove front side V-belt.

<Ref. to ME(H4SO)-43, REMOVAL, V-belt.>

(3) Remove pipe with bracket.

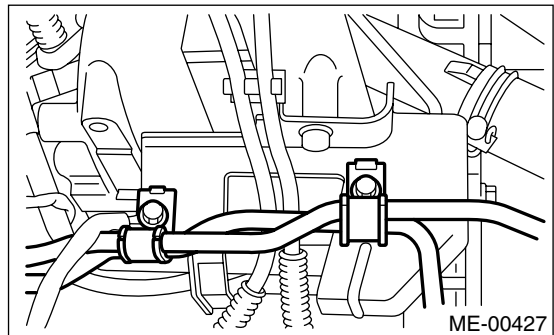

ENGINE ASSEMBLY

MECHANICAL

(4) Remove bolts which install power steering pump bracket.

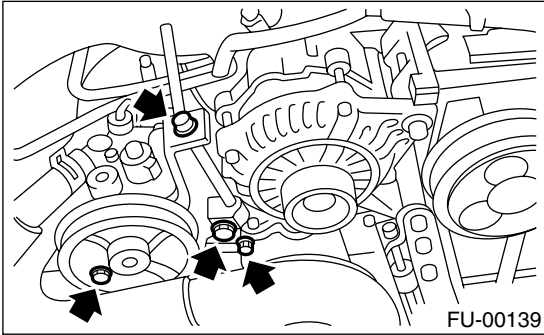

(5) Remove power steering tank from the bracket by pulling it upward.

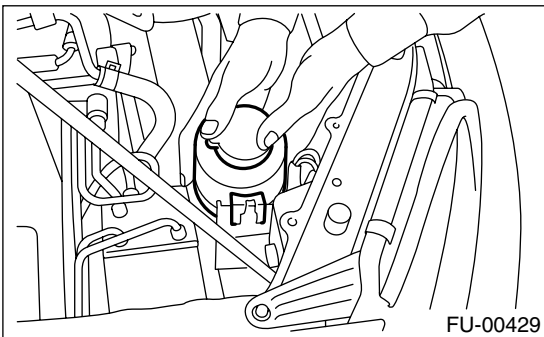

(6) Place power steering pump on the right side wheel apron.

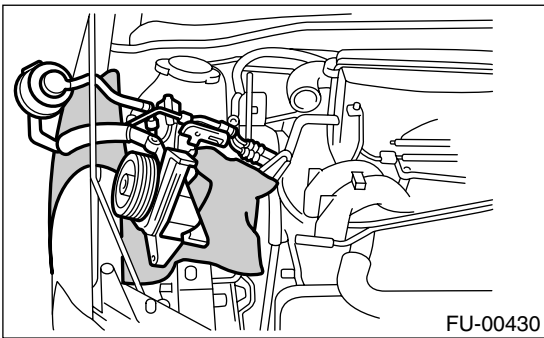

16) Remove front and center exhaust pipe.
<Ref. to EX(H4SO)-5, REMOVAL, Front Exhaust Pipe.> and <Ref. to EX(H4SO)-8, REMOVAL, Center Exhaust Pipe.>

17) Remove nuts which hold lower side of transmission to engine.

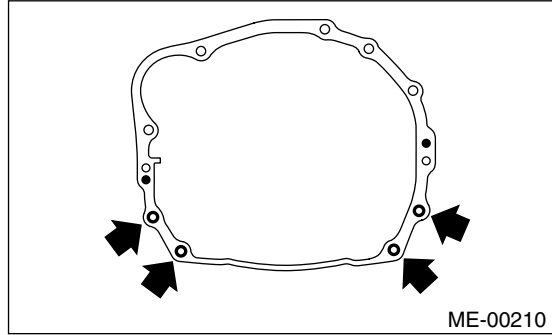

18) Remove nuts which install front cushion rubber onto front crossmember.

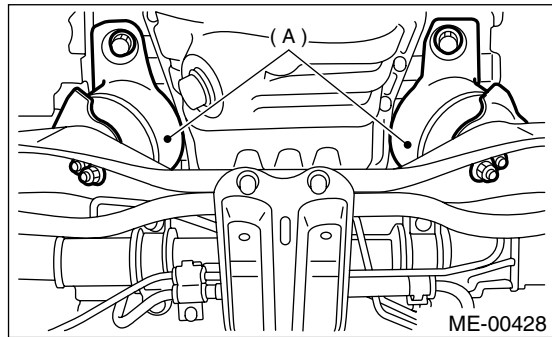

(A) Engine mount

19) Separate torque converter clutch from drive plate. (AT model)

- (1) Lower the vehicle.
- (2) Remove service hole plug.
- (3) Remove bolts which hold torque converter clutch to drive plate.
- (4) Remove other bolts while rotating the crankshaft pulley using ST.

ST 499977100 CRANK PULLEY WRENCH

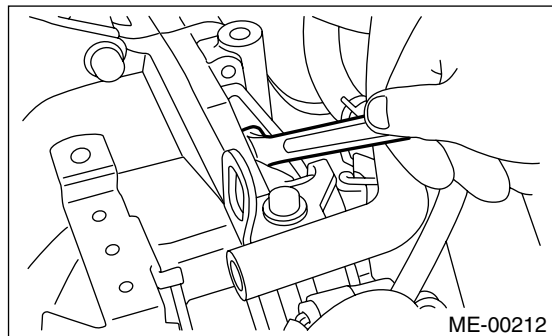

20) Remove pitching stopper.

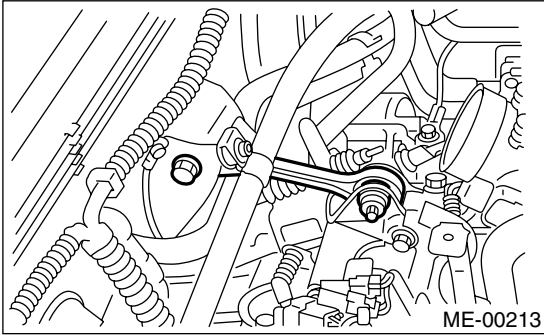

21) Disconnect fuel delivery hose, return hose and evaporation hose.

CAUTION:

- Disconnect hose with its end wrapped with cloth to prevent fuel from splashing.
- Catch fuel from hose into container.

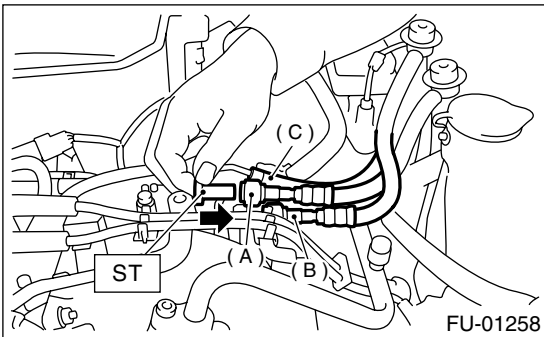

- (A) Fuel delivery hose
- (B) Return hose
- (C) Evaporation hose

22) Support engine with a lifting device and wire ropes.

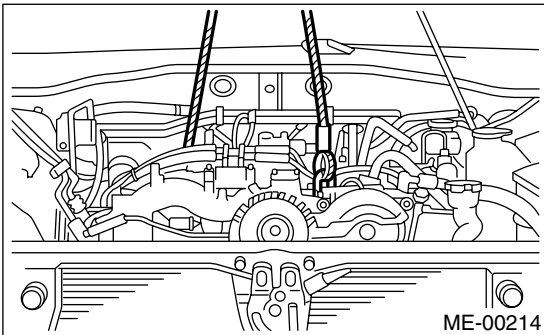

23) Support transmission with a garage jack.

CAUTION:

Before moving engine away from transmission, check to be sure no work has been overlooked. Doing this is very important in order to facilitate re-installation and because transmission lowers under its own weight.

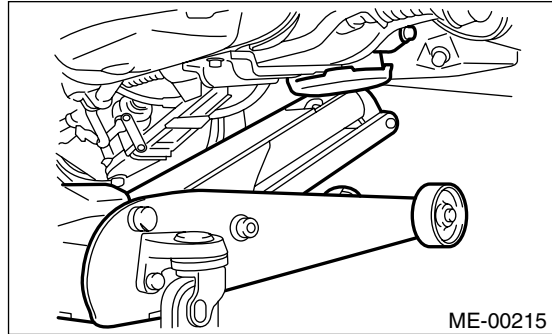

24) Separation of engine and transmission.

- (1) Remove starter. <Ref. to SC(H4SO)-7, REMOVAL, Starter.>
- (2) Remove bolts which hold upper side of transmission to engine.

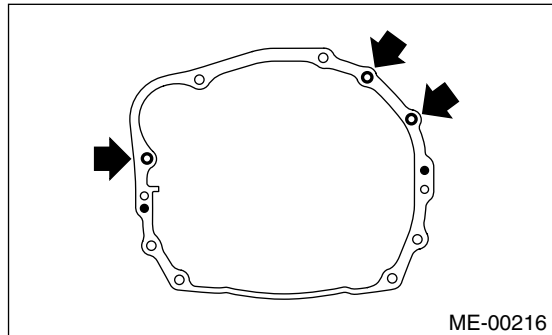

25) Install ST to torque converter clutch case. (AT model)

ST 498277200 STOPPER SET

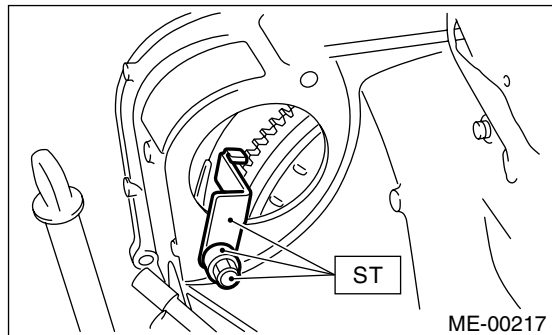

ENGINE ASSEMBLY

MECHANICAL

- 26) Remove engine from vehicle.
- (1) Slightly raise engine.
 - (2) Raise transmission with garage jack.
 - (3) Move engine horizontally until main shaft is withdrawn from clutch cover.
 - (4) Slowly move engine away from engine room.

CAUTION:

Be careful not to damage adjacent parts or body panels with crank pulley, oil level gauge, etc.

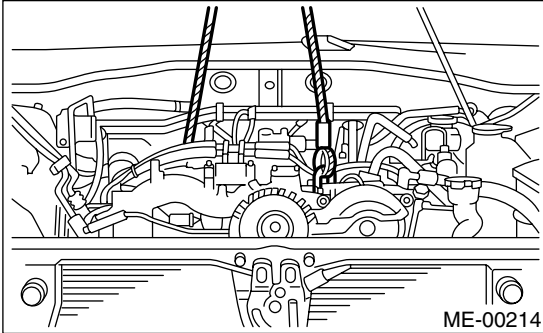

- 27) Remove front cushion rubbers.

B: INSTALLATION

- 1) Install front cushion rubbers.

Tightening torque:

35 N·m (3.6 kgf-m, 26.0 ft-lb)

- 2) Install engine onto transmission.
- (1) Position engine in engine room and align it with transmission.

CAUTION:

Be careful not to damage adjacent parts or body panels with crank pulley, oil level gauge, etc.

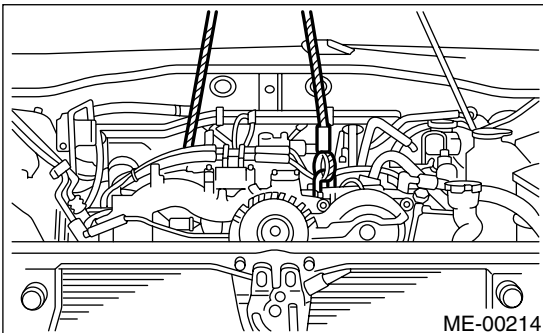

- (2) Apply a small amount of grease to spline of main shaft. (MT model)

- 3) Tighten bolts which hold upper side of transmission to engine.

Tightening torque:

50 N·m (5.1 kgf-m, 36.9 ft-lb)

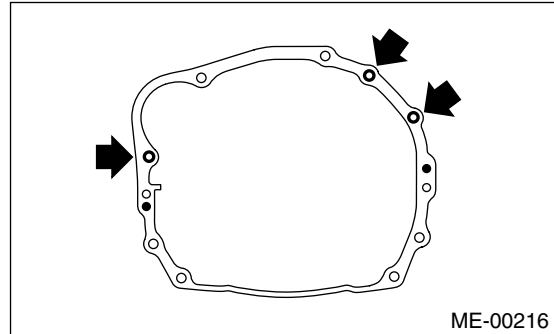

- 4) Remove lifting device and wire ropes.

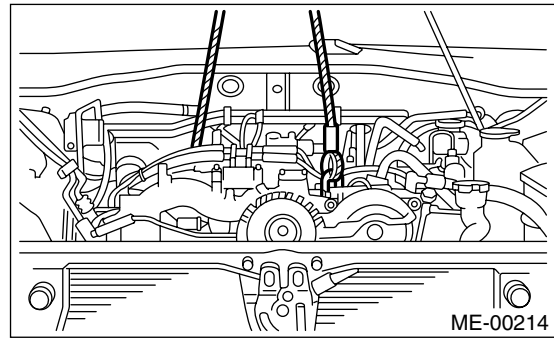

- 5) Remove garage jack.
6) Install pitching stopper.

Tightening torque:

T1: 50 N·m (5.1 kgf-m, 36.9 ft-lb)

T2: 58 N·m (5.9 kgf-m, 43 ft-lb)

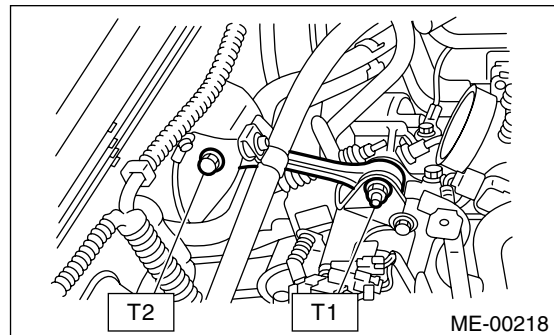

- 7) Remove ST from torque converter clutch case. (AT model)

NOTE:

Be careful not to drop the ST into the torque converter clutch case when removing ST.

ST 498277200 STOPPER SET

- 8) Install starter. <Ref. to SC(H4SO)-7, INSTALLATION, Starter.>

9) Install torque converter clutch onto drive plate.
(AT model)

- (1) Tighten bolts which hold torque converter clutch to drive plate.
- (2) Tighten other bolts while rotating the crankshaft pulley by using ST.

CAUTION:

Be careful not to drop bolts into torque converter clutch housing.

ST 499977100 CRANK PULLEY WRENCH

Tightening torque:

25 N·m (2.5 kgf-m, 18.1 ft-lb)

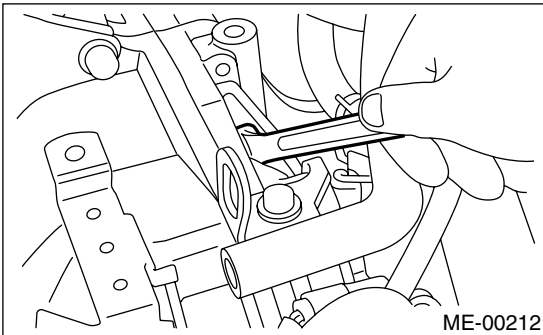

(3) Clog plug onto service hole.

10) Install power steering pump on bracket.

- (1) Install power steering tank on bracket.

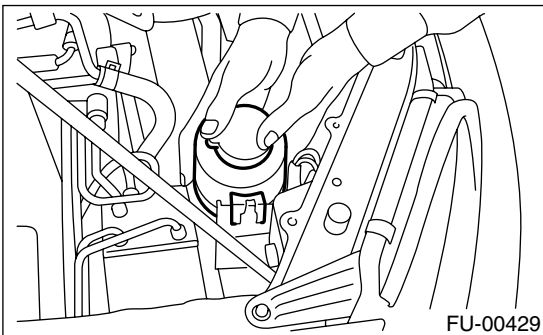

(2) Install power steering pump on bracket, and tighten bolts.

Tightening torque:

20.1 N·m (2.05 kgf-m, 14.8 ft-lb)

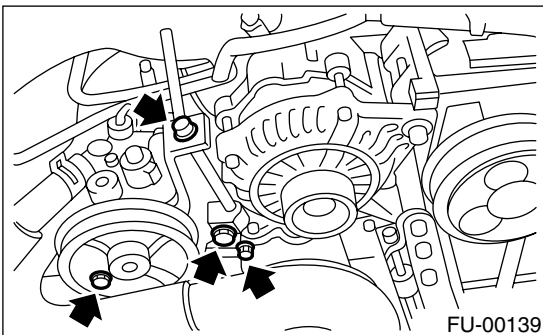

(3) Tighten bolt which installs power steering pump bracket, and install spark plug codes.

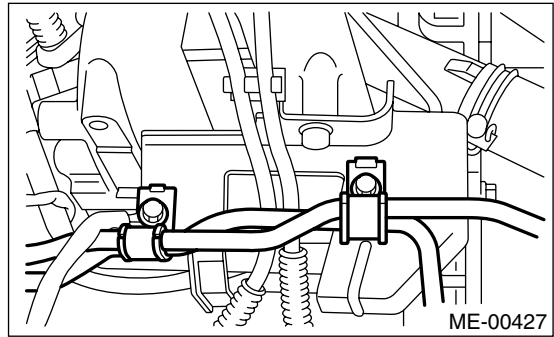

(4) Connect power steering switch connector.

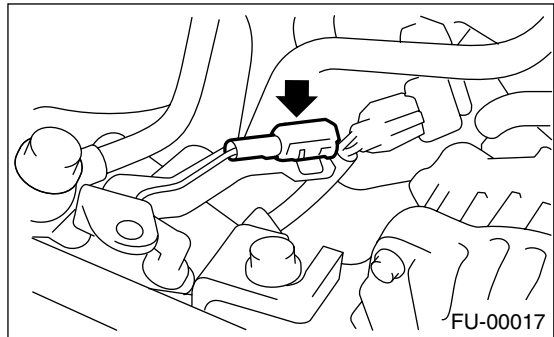

(5) Front side V-belt

Install and adjust it. <Ref. to ME(H4SO)-43, V-belt.>

(6) Install resonator chamber (Except U5).

Tightening torque:

33 N·m (3.4 kgf-m, 24.6 ft-lb)

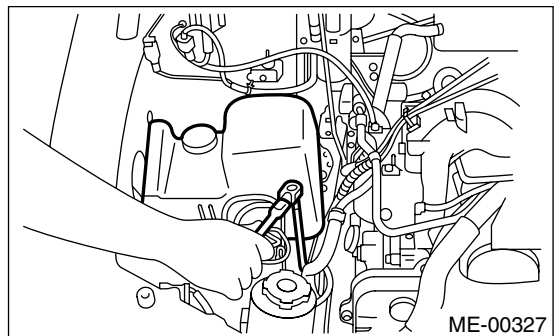

ENGINE ASSEMBLY

MECHANICAL

11) Tighten nuts which hold lower side of transmission to engine.

Tightening torque:

50 N·m (5.1 kgf-m, 36.9 ft-lb)

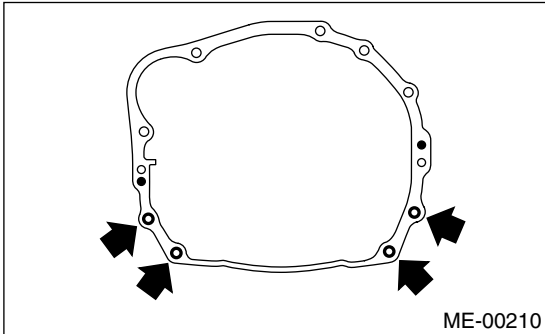

12) Tighten nuts which install front cushion rubber onto crossmember.

Tightening torque:

85 N·m (8.7 kgf-m, 63 ft-lb)

CAUTION:

Make sure the front cushion rubber mounting bolts (A) and locator (B) are securely installed.

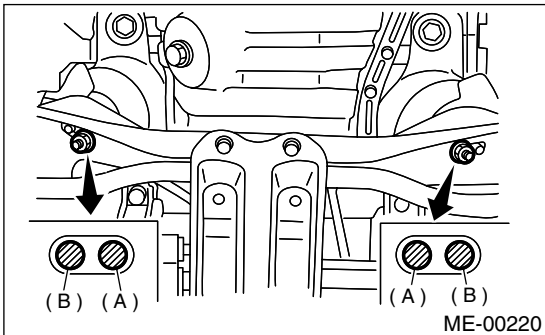

13) Install front and center exhaust pipe. <Ref. to EX(H4SO)-6, INSTALLATION, Front Exhaust Pipe.> and <Ref. to EX(H4SO)-8, INSTALLATION, Center Exhaust Pipe.>

14) Connect the following hoses.

(1) Fuel delivery hose, return hose and evaporation hose <Ref. to FU(H4SO)-73, INSTALLATION, Fuel Delivery, Return and Evaporation Lines.>

(2) Heater inlet and outlet hoses

(3) Brake booster vacuum hose

15) Connect the following connectors.

(1) Engine ground terminals

Tightening torque:

14 N·m (1.4 kgf-m, 10.1 ft-lb)

(2) Engine harness connectors

(3) Alternator connector and terminal

(4) A/C compressor connectors

(5) Power steering pressure switch

16) Connect the following cables.

(1) Accelerator cable

(2) Cruise control cables (With cruise control)

17) After connecting each cable, adjust them.

18) Install air cleaner case stay.

Tightening torque:

16 N·m (1.6 kgf-m, 11.6 ft-lb)

19) Install A/C pressure hoses.

<Ref. to AC-38, INSTALLATION, Flexible Hose.>

20) Install radiator to vehicle. <Ref. to CO(H4SO)-21, INSTALLATION, Radiator.>

21) Install ATF cooler pipe to body. <Ref. to 4AT-84, INSTALLATION, ATF Cooler Pipe and Hose.>

22) Install air intake duct and cleaner case.

<Ref. to IN(H4SO)-6, INSTALLATION, Air Intake Duct.> and <Ref. to IN(H4SO)-5, INSTALLATION, Air Cleaner Case.>

23) Install under cover.

24) Install battery in the vehicle, and connect cables.

25) Fill coolant.

<Ref. to CO(H4SO)-12, FILLING OF ENGINE COOLANT, REPLACEMENT, Engine Coolant.>

26) Check ATF level and correct if necessary. (AT model)

<Ref. to 4AT-31, Automatic Transmission Fluid.>

27) Charge A/C system with refrigerant.

<Ref. to AC-21, OPERATION, Refrigerant Charging Procedure.>

28) Remove front hood stay, and close front hood.

29) Take off the vehicle from lift arms.

C: INSPECTION

1) Make sure pipes and hoses are installed correctly.

2) Make sure the engine coolant and ATF are at specified levels.

10.Engine Mounting

A: REMOVAL

- 1) Remove engine assembly. <Ref. to ME(H4SO)-34, REMOVAL, Engine Assembly.>
- 2) Remove engine mounting from engine assembly.

B: INSTALLATION

Install in the reverse order of removal.

Tightening torque:

Engine mounting;

35 N·m (3.6 kgf-m, 26.0 ft-lb)

C: INSPECTION

Make sure there are no cracks or other damage.

11. Preparation for Overhaul

A: PROCEDURE

1) After removing the engine from the body, secure it in the ST shown below.

ST1	498457000	ENGINE STAND ADAPTER RH
ST2	498457100	ENGINE STAND ADAPTER LH
ST3	499817100	ENGINE STAND

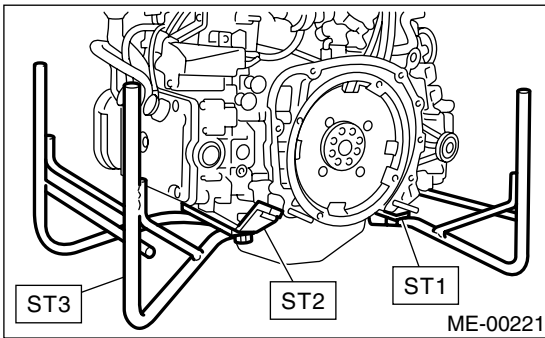

2) In this section the procedures described under each index are all connected and stated in order. It will be the complete procedure for overhauling of the engine itself when you go through all steps in the process.

Therefore, in this section, to conduct the particular procedure within the flow of a section, you need to go back and conduct the procedure described previously in order to do that particular procedure.

12.V-belt

A: REMOVAL

1. FRONT SIDE BELT

NOTE:

Perform the following procedures 1) to 4) with the engine installed to the body.

- 1) Remove V-belt cover.

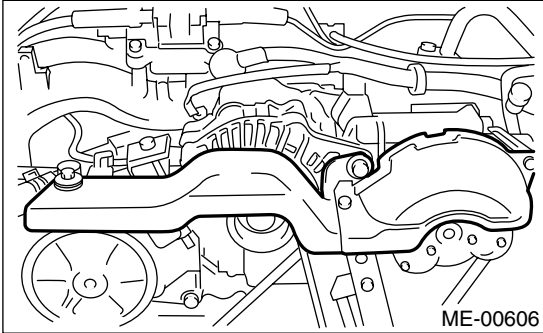

- 2) Loosen the lock bolt (A).
- 3) Loosen the slider bolt (B).
- 4) Remove the front side belt (C).

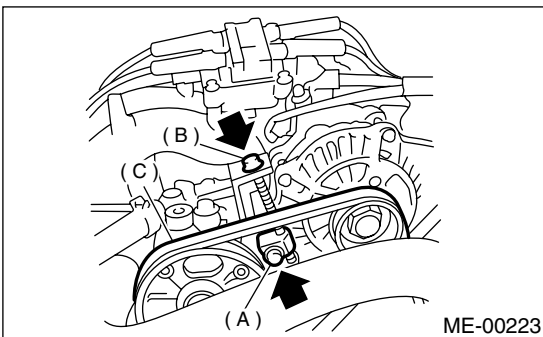

2. REAR SIDE BELT

- 1) Loosen the lock nut (A).
- 2) Loosen the slider bolt (B).

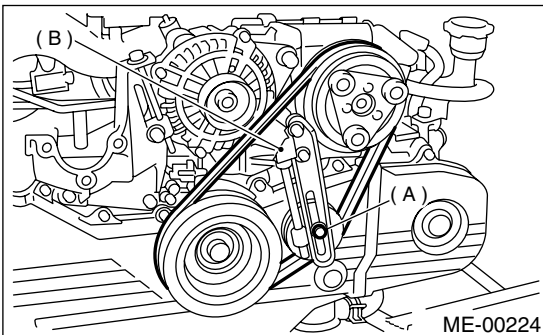

- 3) Remove the A/C belt.
- 4) Remove the A/C belt tensioner.

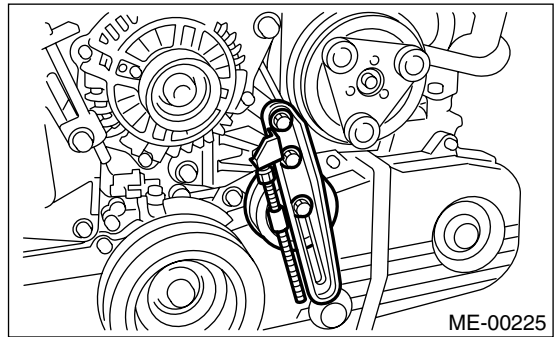

B: INSTALLATION

1. FRONT SIDE BELT

- 1) Wipe off any oil or water on the belt and pulley.
- 2) Install a belt (C), and tighten the slider bolt so as to obtain the specified belt tension <Ref. to ME(H4SO)-44, INSPECTION, V-belt.>
- 3) Tighten the lock bolt (A).
- 4) Tighten slider bolt (B).

Tightening torque:

Lock bolt through bolt:

25 N·m (2.5 kgf-m, 18 ft-lb)

Slider bolt:

8 N·m (0.8 kgf-m, 5.8 ft-lb)

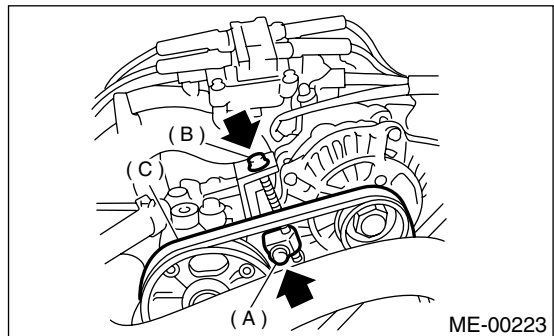

- 5) Install V-belt cover.

V-BELT

MECHANICAL

2. REAR SIDE BELT

- 1) Install a belt, and tighten the slider bolt (B) so as to obtain the specified belt tension. <Ref. to ME(H4SO)-44, INSPECTION, V-belt.>
- 2) Tighten the lock nut (A).

Tightening torque:

Lock nut (A);
22.6 N·m (2.3 kgf·m, 16.6 ft·lb)

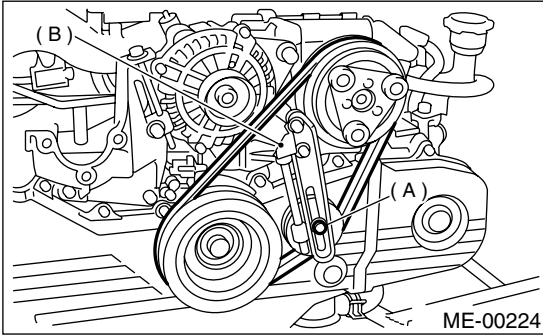

C: INSPECTION

1. WITHOUT BELT TENSION GAUGE

- 1) Replace belts, if cracks, fraying or wear is found.
- 2) Check drive belt tension and adjust it if necessary by changing generator installing position and/or idler pulley installing position.

Belt tension

(A)
new: 7 — 9 mm (0.276 — 0.354 in)
reused: 9 — 11 mm (0.354 — 0.433 in)
(B)*
new: 7.5 — 8.5 mm (0.295 — 0.335 in)
reused: 9.0 — 10.0 mm (0.354 — 0.394 in)

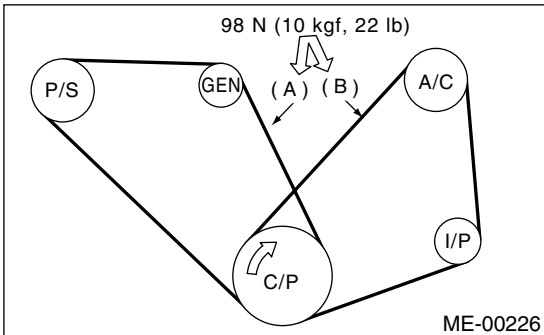

C/P Crankshaft pulley
GEN Generator
P/S Power steering oil pump pulley
A/C Air conditioning compressor pulley
I/P Idler pulley

2. WITH BELT TENSION GAUGE

- 1) Replace belts, if cracks, fraying or wear is found.
- 2) Check drive belt tension and adjust it if necessary by changing generator installing position and/or idler pulley installing position.

Belt tension

(A)
490 — 640 N (50 — 65 kgf, 110 — 144 lb)
(B)*
350 — 450 N (36 — 46 kgf, 79 — 101 lb)

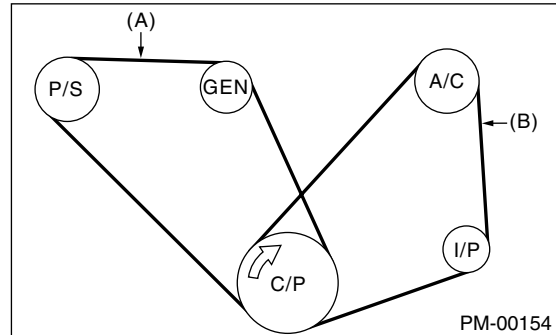

C/P Crankshaft pulley
GEN Generator
P/S Power steering oil pump pulley
A/C Air conditioning compressor pulley
I/P Idler pulley

13. Crankshaft Pulley

A: REMOVAL

1) Remove V-belt. <Ref. to ME(H4SO)-43, REMOVAL, V-belt.>

2) Remove crankshaft pulley bolt. To lock crankshaft, use ST.

ST 499977100

CRANKSHAFT PULLEY WRENCH

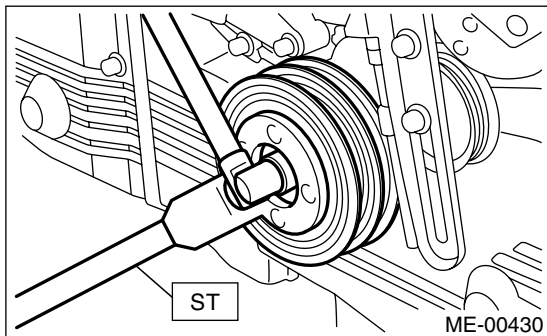

3) Remove crankshaft pulley.

B: INSTALLATION

1) Install crankshaft pulley.

2) Install pulley bolt.

To lock crankshaft, use ST.

ST 499977100 CRANKSHAFT PULLEY WRENCH

(1) Clean the crankshaft pulley thread using an air gun.

(2) Apply engine oil to the crankshaft pulley bolt seat and thread.

(3) Tighten the bolts temporarily with tightening torque of 44 N·m (4.5 kgf-m, 33 ft-lb).

(4) Tighten the crankshaft pulley bolts.

Tightening torque:

177 N·m (18.0 kgf-m, 130.2 ft-lb)

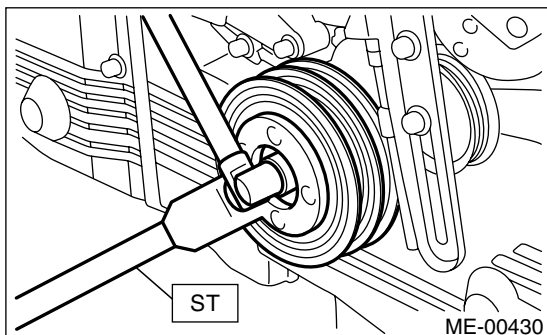

3) Confirm that the tightening angle of the crankshaft pulley bolt is 65 degrees or more. If not, conduct the following procedures (1) through (4).

(1) Replace the crankshaft pulley bolts and clean them.

Crankshaft pulley bolt:
12369AA011

(2) Clean the crankshaft thread using an air gun.

(3) Apply engine oil to the crankshaft pulley bolt seat and thread.

(4) Tighten the bolts temporarily with tightening torque of 44 N·m (4.5 kgf-m, 33 ft-lb).

(5) Tighten the crankshaft pulley bolts keeping them in an angle between 65 degrees and 75 degrees.

NOTE:

Conduct the tightening procedures by confirming the turning angle of the crankshaft pulley bolt referring to the gauge indicated on the belt cover.

4) Install A/C belt tensioner.

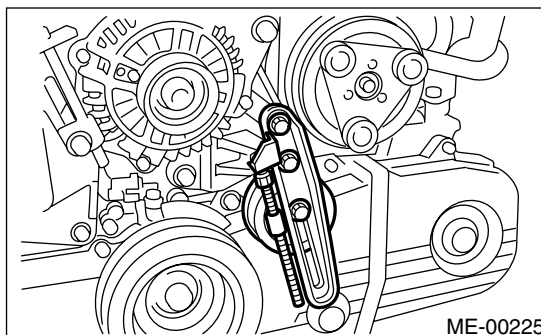

5) Install A/C belt.

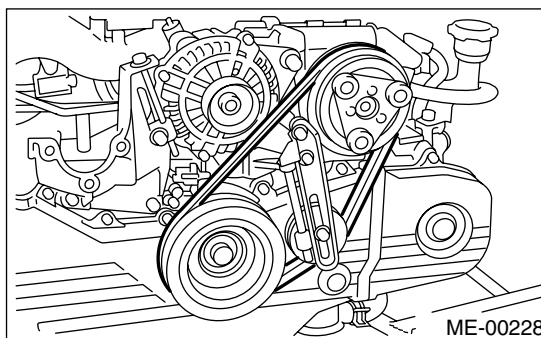

C: INSPECTION

1) Make sure the V-belt is not worn or otherwise damaged.

2) Check the tension of the belt. <Ref. to ME(H4SO)-44, INSPECTION, V-belt.>

14. Belt Cover

A: REMOVAL

- 1) Remove V-belt. <Ref. to ME(H4SO)-43, REMOVAL, V-belt.>
- 2) Remove crankshaft pulley. <Ref. to ME(H4SO)-45, REMOVAL, Crankshaft Pulley.>
- 3) Remove belt cover (LH).
- 4) Remove front belt cover.

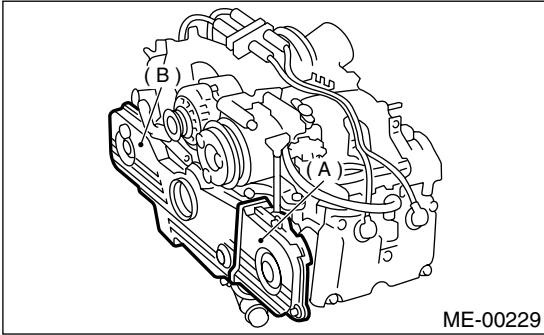

- (A) Belt cover (LH)
- (B) Front belt cover

B: INSTALLATION

- 1) Install front belt cover.

Tightening torque:

5 N·m (0.5 kgf-m, 3.6 ft-lb)

- 2) Install belt cover (LH).

Tightening torque:

5 N·m (0.5 kgf-m, 3.6 ft-lb)

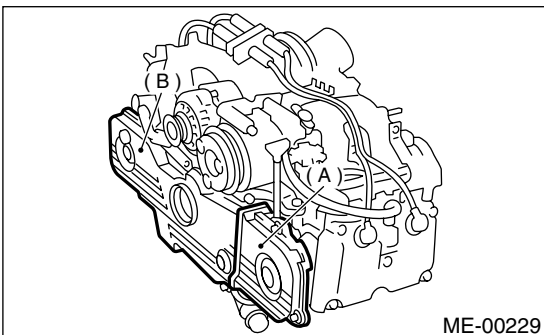

- (A) Belt cover (LH)
- (B) Front belt cover

- 3) Install crankshaft pulley. <Ref. to ME(H4SO)-45, INSTALLATION, Crankshaft Pulley.>
- 4) Install V-belt. <Ref. to ME(H4SO)-43, INSTALLATION, V-belt.>

C: INSPECTION

Make sure the cover is not damaged.

15. Timing Belt Assembly

A: REMOVAL

1. TIMING BELT

- 1) Remove V-belt. <Ref. to ME(H4SO)-43, REMOVAL, V-belt.>
- 2) Remove crankshaft pulley. <Ref. to ME(H4SO)-45, REMOVAL, Crankshaft Pulley.>
- 3) Remove belt cover. <Ref. to ME(H4SO)-46, REMOVAL, Belt Cover.>
- 4) Remove timing belt guide. (MT vehicle only)

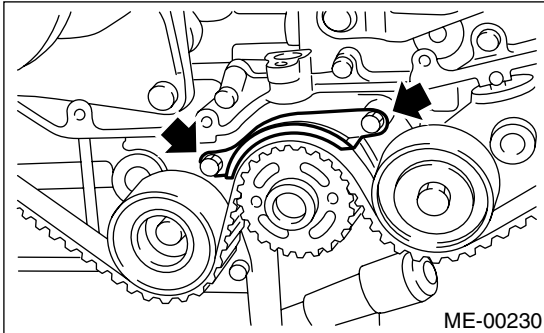

5) If alignment mark (a) and/or arrow mark (which indicates rotation direction) on timing belt fade away, put new marks before removing timing belt as shown in procedures below.

- (1) Turn crankshaft using ST. Align mark (a) of sprocket to cylinder block notch (b) and ensure that right side cam sprocket mark (c), cam cap and cylinder head matching surface (d) and/or left side cam sprocket mark (e) and belt cover notch (f) are properly adjusted.

ST 499987500 CRANKSHAFT SOCKET

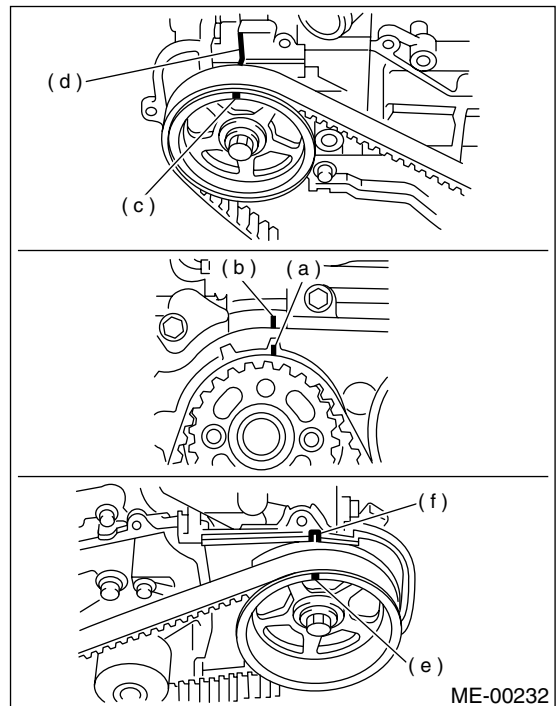
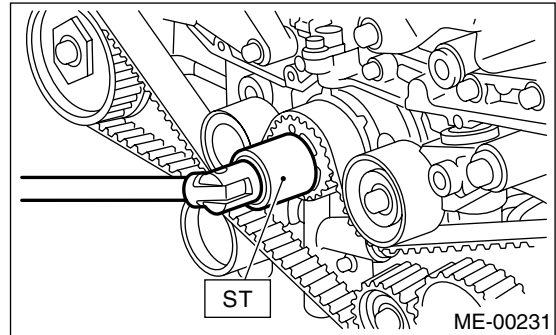

TIMING BELT ASSEMBLY

MECHANICAL

(2) Using white paint, put alignment and/or arrow marks on timing belts in relation to the crank sprocket and cam sprockets.

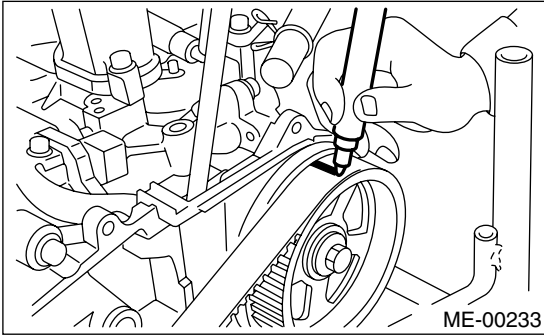

Specified data:

Z_1 : 46.8 tooth length

Z_2 : 43.7 tooth

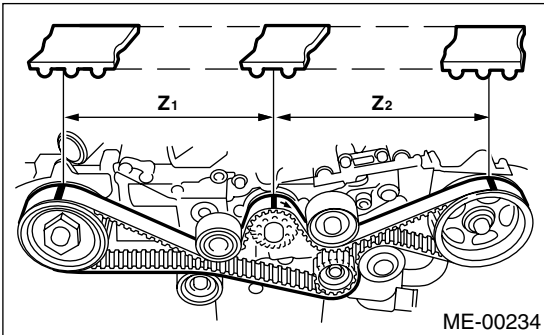

6) Remove belt idler (No. 2).

7) Remove belt idler No. 2.

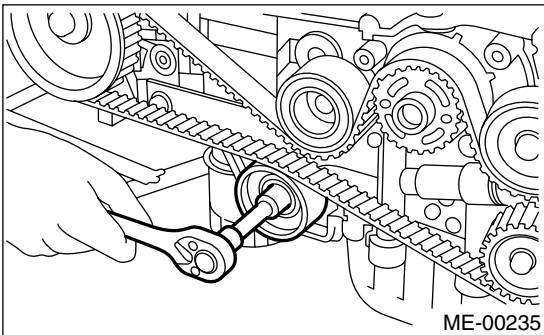

8) Remove timing belt.

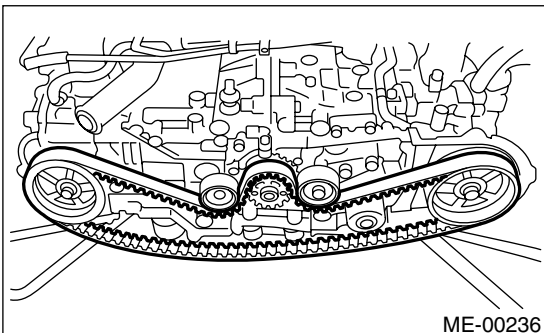

2. BELT IDLER AND AUTOMATIC BELT TENSION ADJUSTER ASSEMBLY

1) Remove belt idler (No. 1).

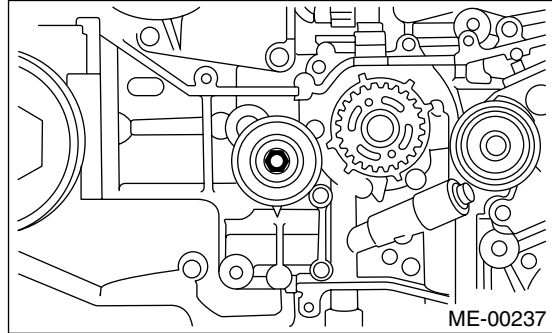

2) Remove automatic belt tension adjuster assembly.

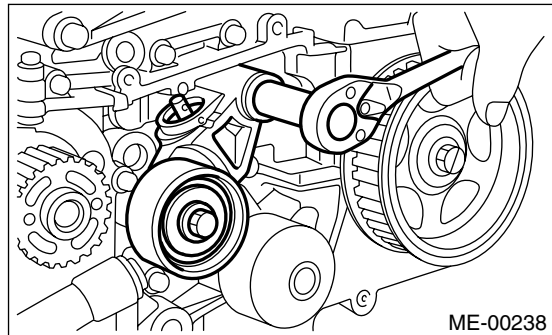

B: INSTALLATION

1. AUTOMATIC BELT TENSION ADJUST-ER ASSEMBLY AND BELT IDLER

1) Preparation for installation of automatic belt tension adjuster assembly;

CAUTION:

- Always use a vertical type pressing tool to move the adjuster rod down.
- Do not use a lateral type vise.
- Push adjuster rod vertically.
- Be sure to slowly move the adjuster rod down applying a pressure of 294 N (30 kgf, 66 lb).
- Press-in the push adjuster rod gradually taking more than three minutes.
- Do not allow press pressure to exceed 9,807 N (1,000 kgf, 2,205 lb).
- Press the adjuster rod as far as the end surface of the cylinder. Do not press the adjuster rod into the cylinder. Doing so may damage the cylinder.
- Do not release press pressure until stopper pin is completely inserted.

(1) Attach the automatic belt tension adjuster assembly to the vertical pressing tool.

(2) Slowly move the adjuster rod down with a pressure of 294 N (30 kgf, 66 lb) until the adjuster rod is aligned with the stopper pin hole in the cylinder.

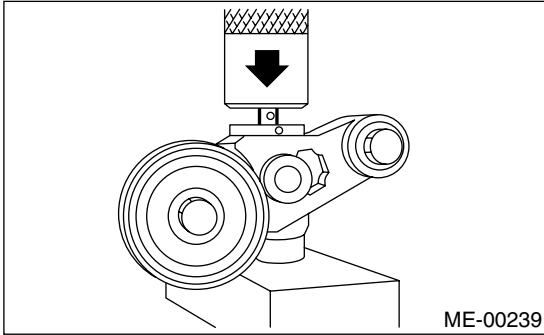

(3) With a 2 mm (0.08 in) dia. stopper pin or a 2 mm (0.08 in) (nominal) dia. hex bar wrench inserted into the stopper pin hole in the cylinder, secure the adjuster rod.

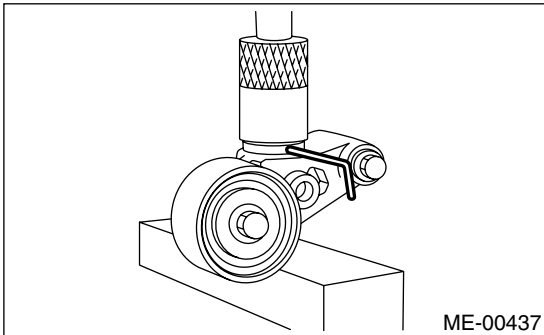

2) Install automatic belt tension adjuster assembly.

Tightening torque:
39 N·m (4.0 kgf·m, 28.9 ft·lb)

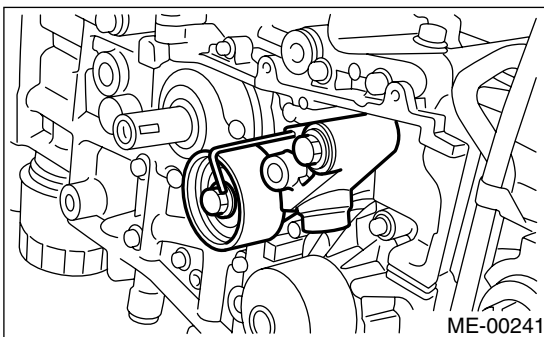

3) Install belt idler (No. 1).

Tightening torque:
39 N·m (4.0 kgf·m, 28.9 ft·lb)

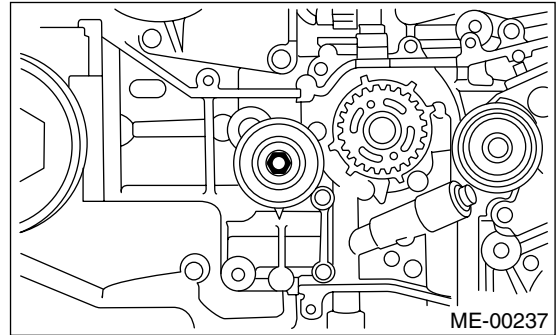

2. TIMING BELT

1) Preparation for installation of automatic belt tension adjuster assembly. <Ref. to ME(H4SO)-48, AUTOMATIC BELT TENSION ADJUSTER ASSEMBLY AND BELT IDLER, INSTALLATION, Timing Belt Assembly.>

2) Installation of timing belt

(1) Turn camshaft sprocket No. 2 using ST1, and turn camshaft sprocket No. 1 using ST2 so that their alignment marks (A) come to top positions.

ST1 18231AA010 CAMSHAFT SPROCKET WRENCH

NOTE:
 CAMSHAFT SPROCKET WRENCH (499207100) is also can be used.

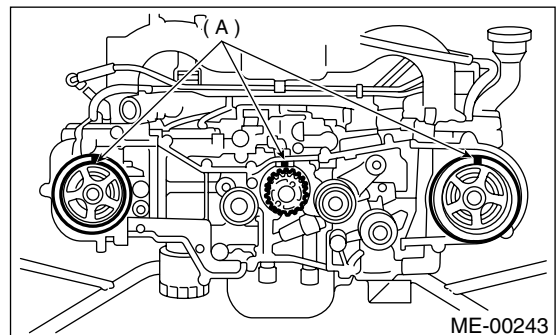

TIMING BELT ASSEMBLY

MECHANICAL

(2) While aligning alignment mark (B) on timing belt with marks on sprockets (A), position timing belt properly.

NOTE:

Ensure belt's rotating direction is correct.

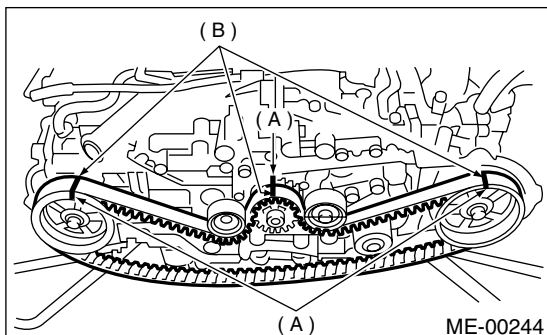

3) Install belt idler No. 2.

Tightening torque:

39 N·m (4.0 kgf-m, 28.9 ft-lb)

4) Install belt idler (No. 2).

Tightening torque:

39 N·m (4.0 kgf-m, 28.9 ft-lb)

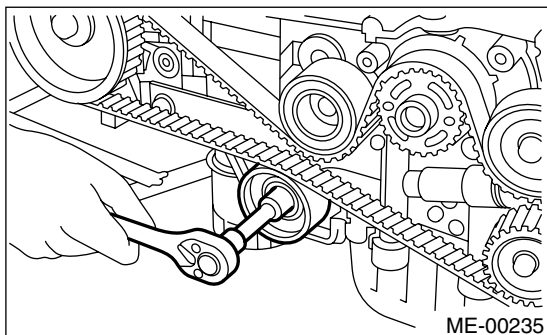

5) After ensuring that the marks on timing belt and camshaft sprockets are aligned, remove stopper pin from belt tensioner adjuster.

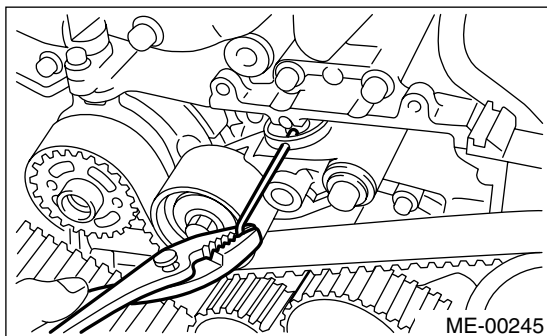

6) Install timing belt guide. (MT vehicles only)

(1) Temporarily tighten bolts.

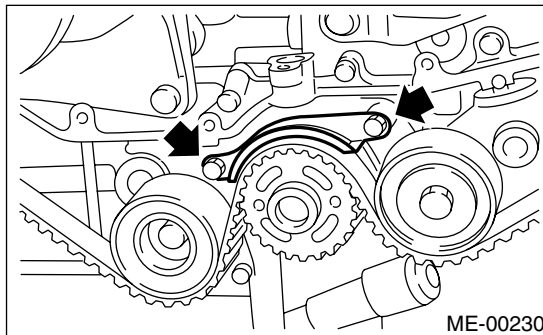

(2) Check and adjust clearance between timing belt and timing belt guide by using thickness gauge.

Clearance:

$1.0 \pm 0.5 \text{ mm (} 0.039 \pm 0.020 \text{ in)}$

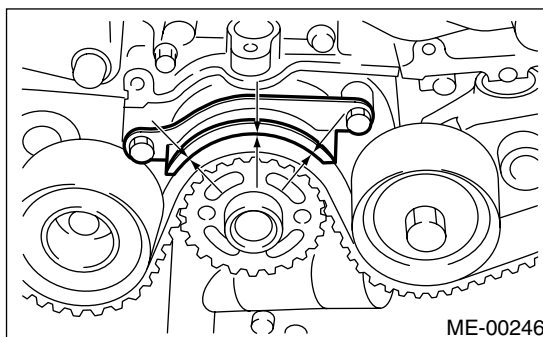

(3) Tighten bolts.

Tightening torque:

10 N·m (1.0 kgf-m, 7.2 ft-lb)

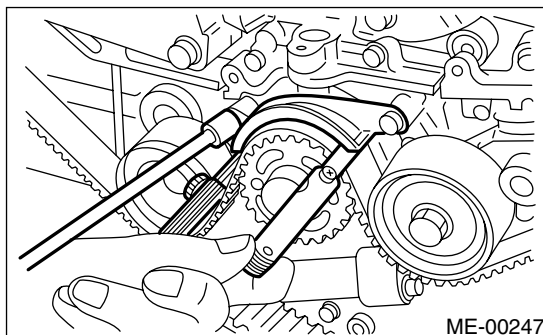

7) Install belt cover. <Ref. to ME(H4SO)-46, INSTALLATION, Belt Cover.>

8) Install crankshaft pulley. <Ref. to ME(H4SO)-45, INSTALLATION, Crankshaft Pulley.>

9) Install V-belt. <Ref. to ME(H4SO)-43, INSTALLATION, V-belt.>

C: INSPECTION

1. TIMING BELT

- 1) Check timing belt teeth for breaks, cracks, and wear. If any fault is found, replace belt.
- 2) Check the condition of back side of belt; if any crack is found, replace belt.

CAUTION:

- Be careful not to let oil, grease or coolant contact the belt. Remove quickly and thoroughly if this happens.
- Do not bend the belt sharply.

Bending radius: h
60 mm (2.36 in) or more

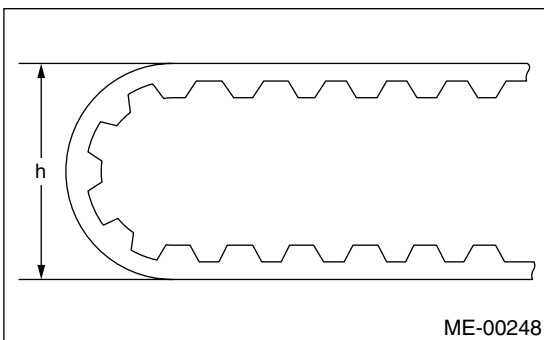

2. AUTOMATIC BELT TENSION ADJUST-ER

- 1) Visually check oil seals for leaks, and rod ends for abnormal wear or scratches. If necessary, replace faulty parts.
- 2) Check that the adjuster rod does not move when a pressure of 294 N (30 kgf, 66 lb) is applied to it. This is to check adjuster rod stiffness.
- 3) If the adjuster rod is not stiff and moves freely when applying 294 N (30 kgf, 66 lb), check it using the following procedures:
 - (1) Slowly press the adjuster rod down to the end surface of the cylinder. Repeat this motion 2 or 3 times.
 - (2) With the adjuster rod moved all the way up, apply a pressure of 294 N (30 kgf, 66 lb) to it. Check adjuster rod stiffness.

- (3) If the adjuster rod is not stiff and moves down, replace the automatic belt tension adjuster assembly with a new one.

CAUTION:

- Always use a vertical type pressing tool to move the adjuster rod down.
- Do not use a lateral type vise.
- Push adjuster rod vertically.
- Press-in the push adjuster rod gradually taking more than three minutes.
- Do not allow press pressure to exceed 9,807 N (1,000 kgf, 2,205 lb).
- Press the adjuster rod as far as the end surface of the cylinder. Do not press the adjuster rod into the cylinder. Doing so may damage the cylinder.

- 4) Measure the extension of rod beyond the body. If it is not within specifications, replace with a new one.

Rod extension: H
5.7±0.5 mm (0.224±0.020 in)

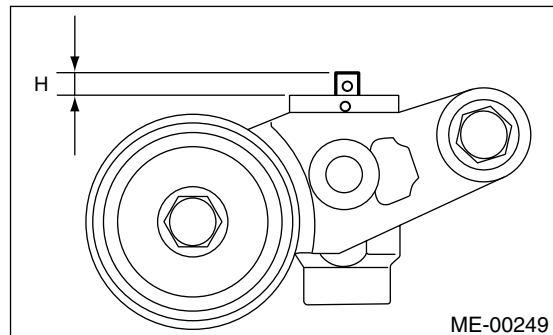

3. BELT TENSION PULLEY

- 1) Check mating surfaces of timing belt and contact point of adjuster rod for abnormal wear or scratches. Replace automatic belt tension adjuster assembly if faulty.
- 2) Check tension pulley for smooth rotation. Replace if noise or excessive play is noted.
- 3) Check tension pulley for grease leakage.

4. BELT IDLER

- 1) Check belt idler for smooth rotation. Replace if noise or excessive play is noted.
- 2) Check belt outer contacting surfaces of idler pulley for abnormal wear and scratches.
- 3) Check belt idler for grease leakage.

CAMSHAFT SPROCKET

MECHANICAL

16. Camshaft Sprocket

A: REMOVAL

- 1) Remove V-belt. <Ref. to ME(H4SO)-43, REMOVAL, V-belt.>
- 2) Remove crankshaft pulley. <Ref. to ME(H4SO)-45, REMOVAL, Crankshaft Pulley.>
- 3) Remove belt cover. <Ref. to ME(H4SO)-46, REMOVAL, Belt Cover.>
- 4) Remove timing belt assembly. <Ref. to ME(H4SO)-47, REMOVAL, Timing Belt Assembly.>
- 5) Remove camshaft position sensor. <Ref. to FU(H4SO)-29, REMOVAL, Camshaft Position Sensor.>
- 6) Remove camshaft sprocket No. 1 and No. 2. To lock camshaft, use ST.
ST 18231AA010 CAMSHAFT SPROCKET WRENCH

NOTE:
CAMSHAFT SPROCKET WRENCH (499207100) is also can be used.

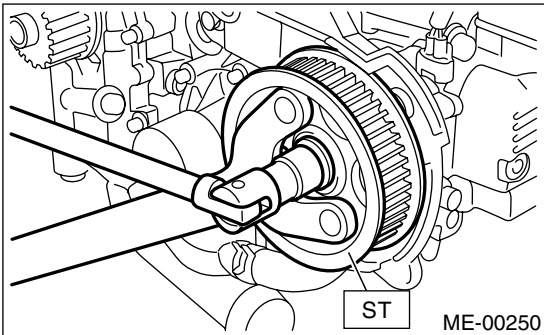

B: INSTALLATION

- 1) Install camshaft sprocket No. 1 and No. 2. To lock camshaft, use ST.
ST 18231AA010 CAMSHAFT SPROCKET WRENCH

NOTE:
CAMSHAFT SPROCKET WRENCH (499207100) is also can be used.

Tightening torque:
78 N·m (8.0 kgf-m, 57.9 ft-lb)

CAUTION:
Do not confuse left and right side camshaft sprockets during installation. The camshaft sprocket No. 2 is identified by a projection used to monitor camshaft position sensor.

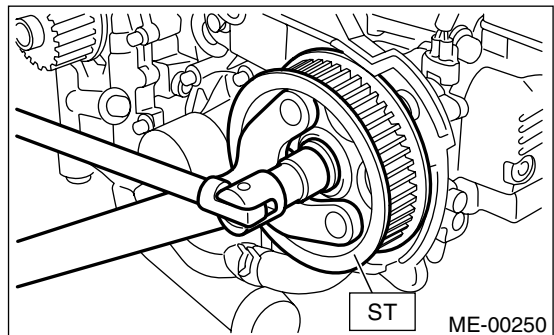

- 2) Install timing belt assembly. <Ref. to ME(H4SO)-48, INSTALLATION, Timing Belt Assembly.>
- 3) Install belt cover. <Ref. to ME(H4SO)-46, INSTALLATION, Belt Cover.>
- 4) Install crankshaft pulley. <Ref. to ME(H4SO)-45, INSTALLATION, Crankshaft Pulley.>
- 5) Install V-belt. <Ref. to ME(H4SO)-43, INSTALLATION, V-belt.>

C: INSPECTION

- 1) Check sprocket teeth for abnormal wear and scratches.
- 2) Make sure there is no free play between sprocket and key.
- 3) Check crankshaft sprocket notch for sensor for damage and contamination of foreign matter.

17.Crankshaft Sprocket

A: REMOVAL

- 1) Remove V-belt. <Ref. to ME(H4SO)-43, REMOVAL, V-belt.>
- 2) Remove crankshaft pulley. <Ref. to ME(H4SO)-45, REMOVAL, Crankshaft Pulley.>
- 3) Remove belt cover. <Ref. to ME(H4SO)-46, REMOVAL, Belt Cover.>
- 4) Remove timing belt assembly. <Ref. to ME(H4SO)-47, REMOVAL, Timing Belt Assembly.>
- 5) Remove camshaft sprocket. <Ref. to ME(H4SO)-52, REMOVAL, Camshaft Sprocket.>
- 6) Remove crankshaft sprocket.

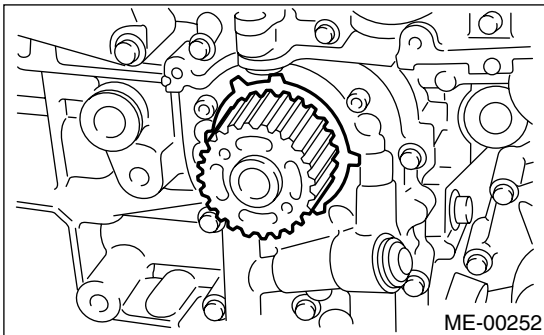

B: INSTALLATION

- 1) Install crankshaft sprocket.

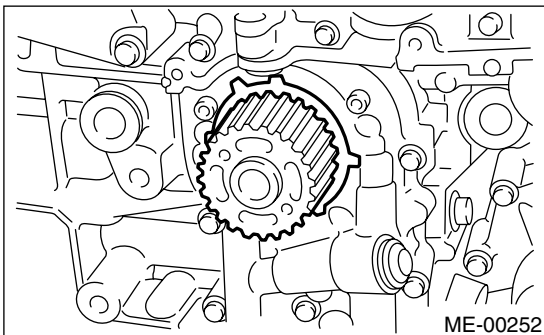

- 2) Install camshaft sprocket. <Ref. to ME(H4SO)-52, INSTALLATION, Camshaft Sprocket.>
- 3) Install timing belt assembly. <Ref. to ME(H4SO)-48, INSTALLATION, Timing Belt Assembly.>
- 4) Install belt cover. <Ref. to ME(H4SO)-46, INSTALLATION, Belt Cover.>
- 5) Install crankshaft pulley. <Ref. to ME(H4SO)-45, INSTALLATION, Crankshaft Pulley.>
- 6) Install V-belt. <Ref. to ME(H4SO)-43, INSTALLATION, V-belt.>

C: INSPECTION

- 1) Check sprocket teeth for abnormal wear and scratches.
- 2) Make sure there is no free play between sprocket and key.
- 3) Check crankshaft sprocket notch for sensor for damage and contamination of foreign matter.

VALVE ROCKER ASSEMBLY

MECHANICAL

18. Valve Rocker Assembly

A: REMOVAL

- 1) Remove V-belt. <Ref. to ME(H4SO)-43, REMOVAL, V-belt.>
- 2) Remove crankshaft pulley. <Ref. to ME(H4SO)-45, REMOVAL, Crankshaft Pulley.>
- 3) Remove belt cover. <Ref. to ME(H4SO)-46, REMOVAL, Belt Cover.>
- 4) Remove timing belt assembly. <Ref. to ME(H4SO)-47, REMOVAL, Timing Belt Assembly.>
- 5) Remove camshaft sprocket. <Ref. to ME(H4SO)-52, REMOVAL, Camshaft Sprocket.>
- 6) Disconnect PCV hose and remove rocker cover.
- 7) Removal of valve rocker assembly
 - (1) Remove bolts (a) through (h) in alphabetical sequence.

NOTE:

Leave two or three threads of bolts (g and h) engaged to retain valve rocker assembly.

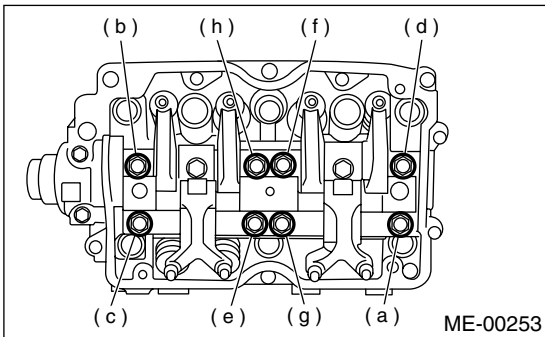

- (2) Remove valve rocker assembly.

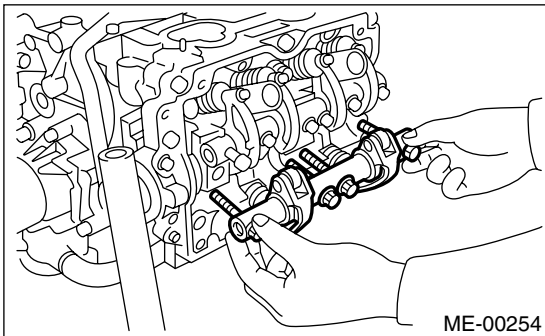

B: INSTALLATION

- 1) Installation of valve rocker assembly
 - (1) Temporarily tighten bolts (a) through (d) in alphabetical order equally as shown in figure.

NOTE:

Do not allow valve rocker assembly to gouge knock pins.

- (2) Tighten bolts (e) through (h) in alphabetical order to specified torque.
- (3) Tighten bolts (a) through (d) in alphabetical order to specified torque.

Tightening torque:

25 N·m (2.5 kgf-m, 18.1 ft-lb)

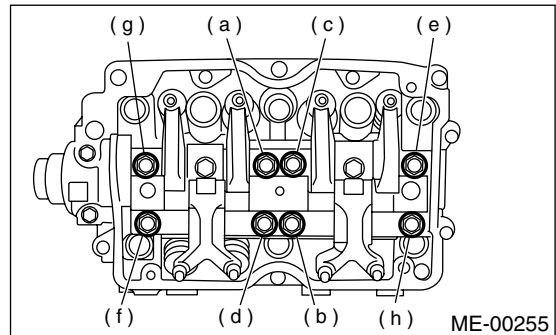

- 2) Adjust the valve clearances. <Ref. to ME(H4SO)-32, ADJUSTMENT, Valve Clearance.>
- 3) Install rocker cover and connect PCV hose.
- 4) Install camshaft sprocket. <Ref. to ME(H4SO)-52, INSTALLATION, Camshaft Sprocket.>
- 5) Install timing belt assembly. <Ref. to ME(H4SO)-48, INSTALLATION, Timing Belt Assembly.>
- 6) Install belt cover. <Ref. to ME(H4SO)-46, INSTALLATION, Belt Cover.>
- 7) Install crankshaft pulley. <Ref. to ME(H4SO)-45, INSTALLATION, Crankshaft Pulley.>
- 8) Install V-belt. <Ref. to ME(H4SO)-43, INSTALLATION, V-belt.>

C: DISASSEMBLY

- 1) Remove bolts which secure rocker shaft.
- 2) Extract rocker shaft. Remove valve rocker arms, springs, plates and shaft supports from rocker shaft.

NOTE:

Arrange all removed parts in order so that they can be installed in their original positions.

- 3) Remove nut and adjuster screw from valve rocker.

D: ASSEMBLY

- 1) Install adjuster screw and nut to valve rocker.
- 2) Arrange valve rocker arms, springs and shaft supports in assembly order and insert valve rocker shaft.

Tightening torque (Shaft supports installing bolts):

5 N·m (0.5 kgf·m, 3.6 ft·lb)

NOTE:

Valve rocker arms, rocker shaft and shaft supports have identification marks. Ensure parts with same markings are properly assembled.

- 3) Install valve rocker shaft securing bolts.

E: INSPECTION

1. VALVE ROCKER ARM AND ROCKER SHAFT

- 1) Measure inside diameter of valve rocker arm and outside diameter of valve rocker shaft, and determine the difference between the two (= oil clearance).

Clearance between arm and shaft:

Standard

0.020 — 0.054 mm (0.0008 — 0.0021 in)

Limit

0.10 mm (0.0039 in)

- 2) If oil clearance exceeds the limit, replace valve rocker arm or shaft, whichever shows greater amount of wear.

Rocker arm inside diameter:

22.020 — 22.041 mm (0.8669 — 0.8678 in)

Rocker shaft diameter:

21.987 — 22.000 mm (0.8656 — 0.8661 in)

- 3) If cam or valve contact surface of valve rocker arm is worn or dented excessively, replace valve rocker arm.

- 4) Check that valve rocker arm roller rotates smoothly. If not, replace valve rocker arm.

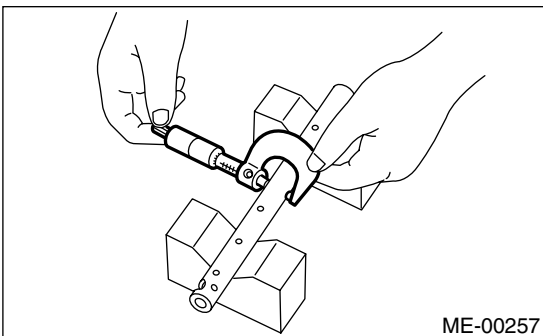
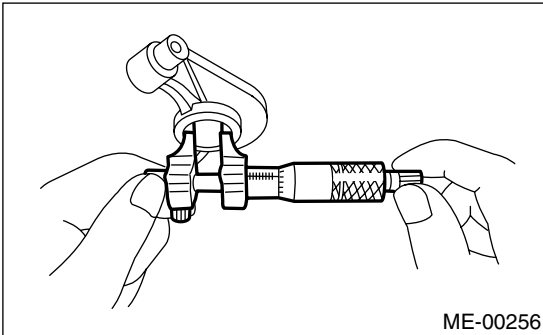

19. Camshaft

A: REMOVAL

- 1) Remove V-belt. <Ref. to ME(H4SO)-43, INSTALLATION, V-belt.>
- 2) Remove crankshaft pulley. <Ref. to ME(H4SO)-45, REMOVAL, Crankshaft Pulley.>
- 3) Remove belt cover. <Ref. to ME(H4SO)-46, REMOVAL, Belt Cover.>
- 4) Remove timing belt assembly. <Ref. to ME(H4SO)-47, REMOVAL, Timing Belt Assembly.>
- 5) Remove camshaft sprocket. <Ref. to ME(H4SO)-52, REMOVAL, Camshaft Sprocket.>
- 6) Remove crankshaft sprocket. <Ref. to ME(H4SO)-53, REMOVAL, Crankshaft Sprocket.>
- 7) Remove belt cover No. 2 (LH).
- 8) Remove belt cover No. 2 (RH).

NOTE:

Do not damage or lose the seal rubber when removing belt covers.

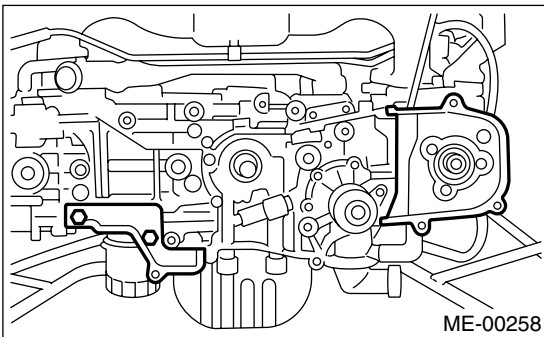

- 9) Remove tensioner bracket.

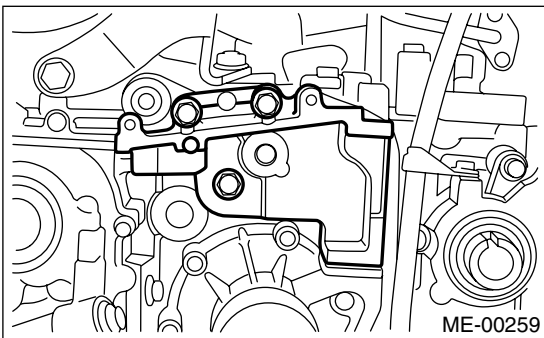

- 10) Remove camshaft position sensor support. (LH side only)
- 11) Remove oil level gauge guide. (LH side only)
- 12) Remove valve rocker assembly. <Ref. to ME(H4SO)-54, REMOVAL, Valve Rocker Assembly.>

- 13) Remove camshaft cap.

- (1) Remove bolts (a) through (b) in alphabetical sequence.

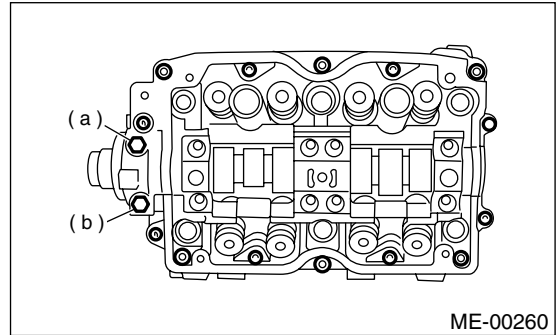

- (2) Equally loosen bolts (c) through (j) all the way in alphabetical sequence.

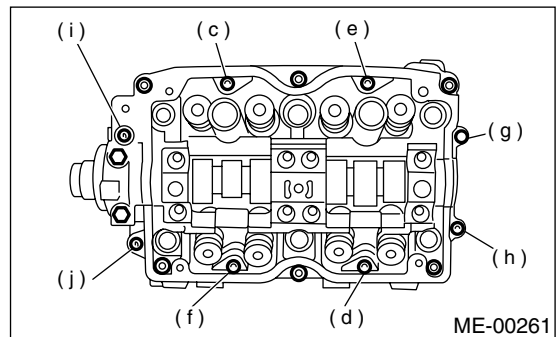

- (3) Remove bolts (k) through (p) in alphabetical sequence using ST.

ST 499497000 TORX PLUS

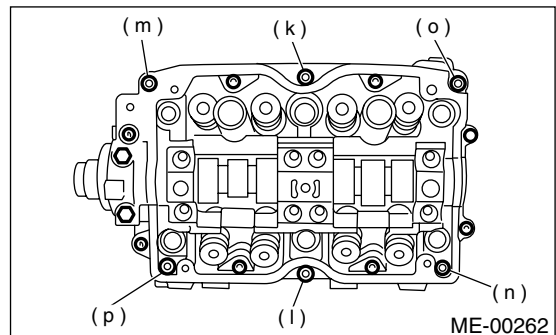

- (4) Remove camshaft cap.

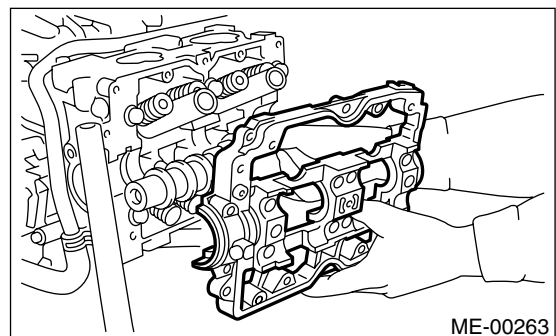

- 14) Remove camshaft.
- 15) Remove oil seal.
- 16) Remove plug from rear side of camshaft.

NOTE:

- Do not remove oil seal unless necessary.
- Do not scratch journal surface when removing oil seal.

B: INSTALLATION

- 1) Apply a coat of engine oil to camshaft journals and install camshaft.
- 2) Install camshaft cap.
 - (1) Apply liquid gasket on the around of camshaft cap.

Liquid gasket:

THREE BOND 1280B
P/N K0877YA018

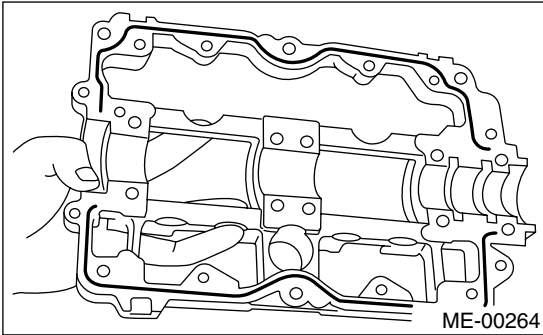

NOTE:

Thinly apply a 3 mm (0.12 in) diameter (A) continuous strip of liquid gasket along edge (B) of camshaft cap (C) mating surface.

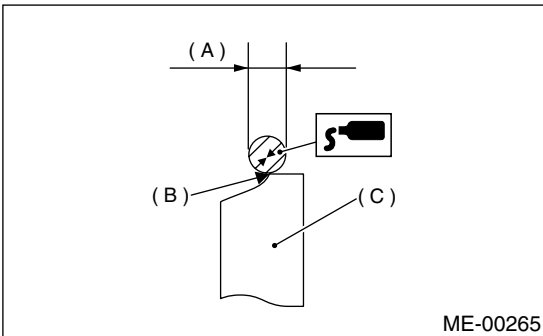

- (2) Temporarily tighten bolts (g) through (j) in alphabetical sequence.

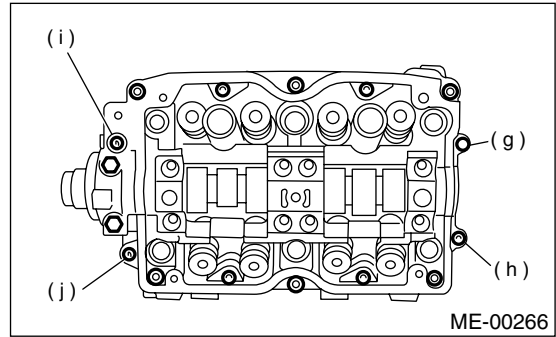

- (3) Install valve rocker assembly.

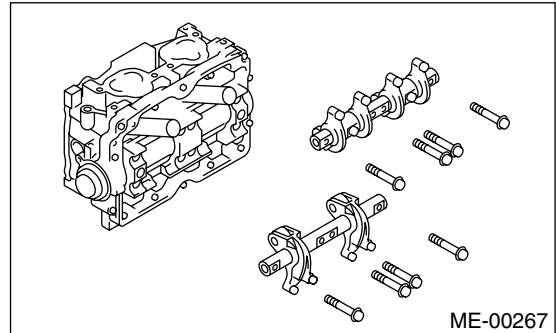

- (4) Tighten bolts (a) through (h) in alphabetical sequence.

Tightening torque:

25 N·m (2.5 kgf-m, 18.1 ft-lb)

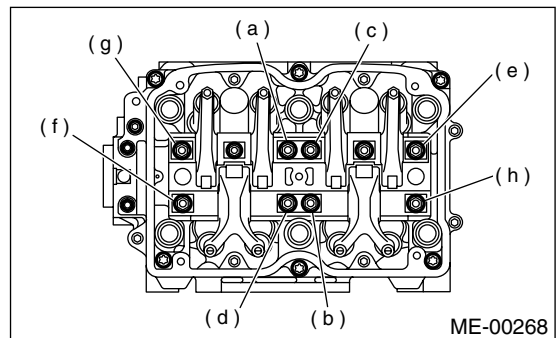

CAMSHAFT

MECHANICAL

(5) Tighten TORX bolts (i) through (n) in alphabetical sequence using ST.

ST 499497000 TORX PLUS

Tightening torque:

18 N·m (1.8 kgf·m, 13.0 ft·lb)

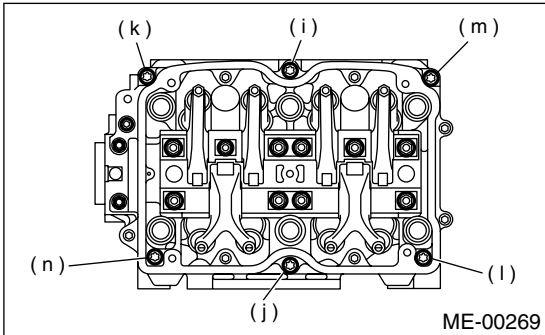

(6) Tighten bolts (o) through (v) in alphabetical sequence.

Tightening torque:

10 N·m (1.0 kgf·m, 7.2 ft·lb)

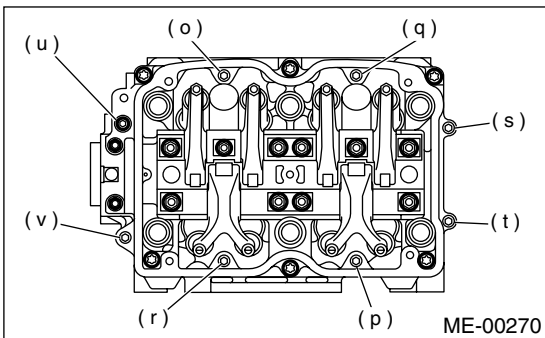

(7) Tighten bolts (w) through (x) in alphabetical sequence.

Tightening torque:

10 N·m (1.0 kgf·m, 7.2 ft·lb)

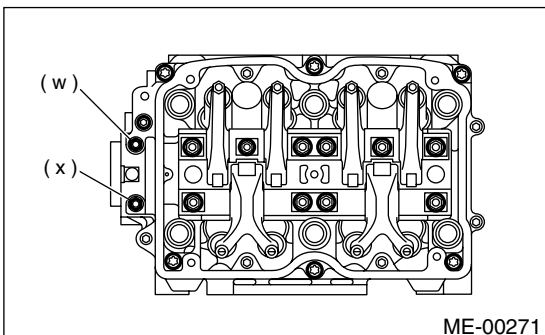

3) Apply a coat of grease to oil seal lips and install oil seal (A) on camshaft using ST1 and ST2.

NOTE:

Use a new oil seal.

ST1 499597000 OIL SEAL GUIDE

ST2 499587500 OIL SEAL INSTALLER

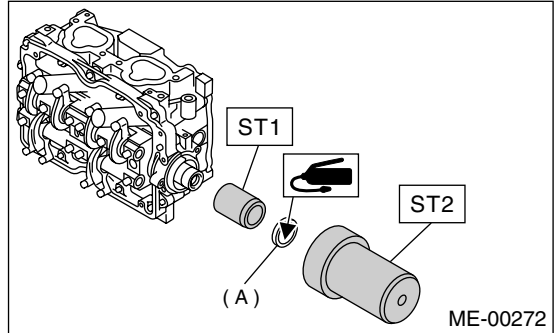

4) Install plug using ST.

ST 499587700 OIL SEAL INSTALLER

5) Adjust the valve clearance. <Ref. to ME(H4SO)-32, ADJUSTMENT, Valve Clearance.>

6) Install rocker cover and connect PCV hose.

7) Install oil level gauge guide. (LH side only)

8) Install camshaft position sensor support. (LH side only)

9) Install tensioner bracket.

Tightening torque:

25 N·m (2.5 kgf·m, 18.1 ft·lb)

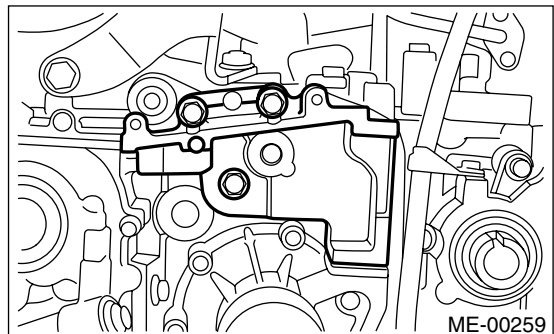

10) Install belt cover No. 2 (RH).

Tightening torque:

5 N·m (0.5 kgf·m, 3.6 ft·lb)

11) Install belt cover No. 2 (LH).

Tightening torque:

5 N·m (0.5 kgf-m, 3.6 ft-lb)

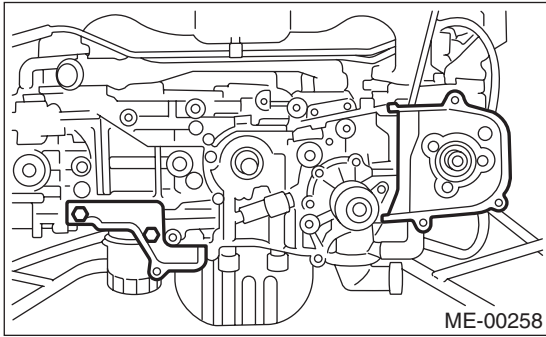

12) Install crankshaft sprocket. <Ref. to ME(H4SO)-53, INSTALLATION, Crankshaft Sprocket.>

13) Install camshaft sprocket. <Ref. to ME(H4SO)-52, INSTALLATION, Camshaft Sprocket.>

14) Install timing belt assembly. <Ref. to ME(H4SO)-48, INSTALLATION, Timing Belt Assembly.>

15) Install belt cover. <Ref. to ME(H4SO)-46, INSTALLATION, Belt Cover.>

16) Install crankshaft pulley. <Ref. to ME(H4SO)-45, INSTALLATION, Crankshaft Pulley.>

17) Install V-belt. <Ref. to ME(H4SO)-43, INSTALLATION, V-belt.>

C: INSPECTION

1. CAMSHAFT

1) Measure the bend, and repair or replace if necessary.

Limit:

0.025 mm (0.00098 in)

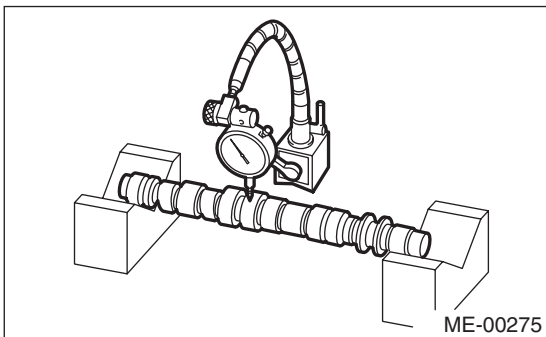

2) Check journal for damage and wear. Replace if faulty.

3) Measure outside diameter of camshaft journal and inside diameter of cylinder head journal, and determine the difference between the two (= oil clearance). If oil clearance exceeds specifications, replace camshaft or cylinder head as necessary.

Unit: mm (in)		
Clearance at journal	Standard	0.055 — 0.090 (0.0022 — 0.0035)
	Limit	0.10 (0.0039)
Camshaft journal O.D.		31.928 — 31.945 (1.2570 — 1.2577)
Journal hole I.D.		32.000 — 32.018 (1.2598 — 1.2605)

4) Check cam face condition; remove minor faults by grinding with oil stone. Measure the cam height H; replace if the limit has been exceeded.

Cam height: H

Item	Unit: mm (in)	
Intake	STD	39.485 — 39.585 (1.5545 — 1.5585)
	Limit	39.385 (1.5506)
Exhaust*1	STD	39.257 — 39.357 (1.5455 — 1.5495)
	Limit	39.157 (1.5416)
Exhaust*2	STD	39.843 — 39.943 (1.5686 — 1.5726)
	Limit	39.743 (1.5647)

*1: Except U5

*2: U5

Cam base circle diameter A:

IN: 34.00 mm (1.3386 in)

EX: 34.00 mm (1.3386 in)

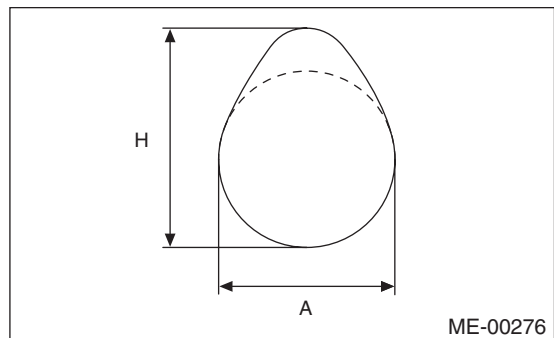

CAMSHAFT

MECHANICAL

2. CAMSHAFT SUPPORT

Measure the thrust clearance of camshaft with dial gauge. If the clearance exceeds the limit, replace camshaft support.

Standard:

0.030 — 0.090 mm (0.0012 — 0.0035 in)

Limit:

0.10 mm (0.0039 in)

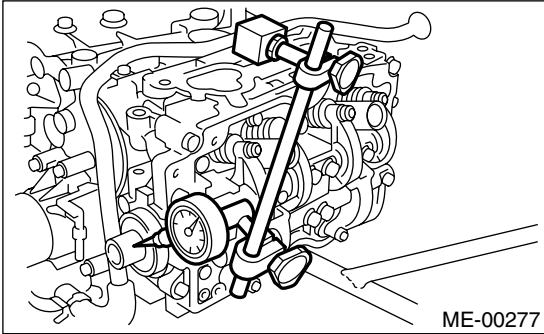

20. Cylinder Head Assembly

A: REMOVAL

- 1) Remove V-belt. <Ref. to ME(H4SO)-43, REMOVAL, V-belt.>
- 2) Remove crankshaft pulley. <Ref. to ME(H4SO)-45, REMOVAL, Crankshaft Pulley.>
- 3) Remove belt cover. <Ref. to ME(H4SO)-46, REMOVAL, Belt Cover.>
- 4) Remove timing belt assembly. <Ref. to ME(H4SO)-47, REMOVAL, Timing Belt Assembly.>
- 5) Remove camshaft sprocket. <Ref. to ME(H4SO)-52, REMOVAL, Camshaft Sprocket.>
- 6) Remove intake manifold. <Ref. to FU(H4SO)-15, REMOVAL, Intake Manifold.>
- 7) Remove bolt which installs A/C compressor bracket on cylinder head.
- 8) Remove valve rocker assembly. <Ref. to ME(H4SO)-54, REMOVAL, Valve Rocker Assembly.>
- 9) Remove camshaft. <Ref. to ME(H4SO)-56, REMOVAL, Camshaft.>
- 10) Remove cylinder head bolts in alphabetical sequence shown in figure.

NOTE:

Leave bolts (a) and (c) engaged by three or four threads to prevent cylinder head from falling.

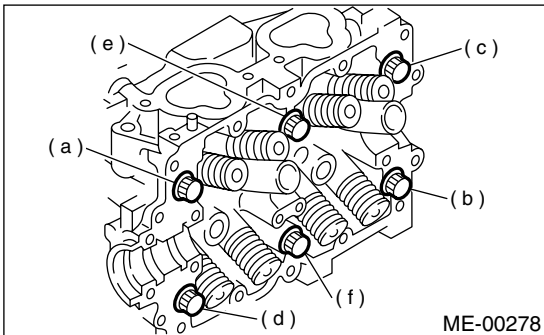

- 11) While tapping cylinder head with a plastic hammer, separate it from cylinder block.
- 12) Remove bolts (a) through (c) to remove cylinder head.

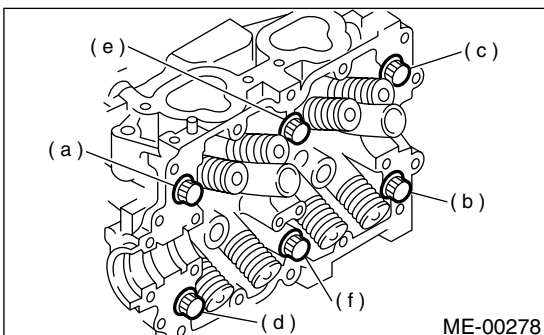

- 13) Remove cylinder head gasket.

CAUTION:

Do not scratch the mating surface of cylinder head and cylinder block.

- 14) Similarly, remove right side cylinder head.

B: INSTALLATION

1. CYLINDER HEAD

- 1) Install cylinder head and gaskets on cylinder block.

CAUTION:

- Use new cylinder head gaskets.
- Be careful not to scratch the mating surface of cylinder block and cylinder head.

- 2) Tighten cylinder head bolts.
 - (1) Apply a coat of engine oil to washers and bolt threads.
 - (2) Tighten all bolts to 29 N·m (3.0 kgf-m, 22 ft-lb) in alphabetical sequence. Then tighten all bolts to 69 N·m (7.0 kgf-m, 51 ft-lb) in alphabetical sequence.
 - (3) Back off all bolts by 180° with reversing order of assembly and after that back them off by 180° again.
 - (4) Tighten bolts (a) and (b) to 34 N·m (3.5 kgf-m, 25 ft-lb).
 - (5) Tighten bolts (c), (d), (e) and (f) to 15 N·m (1.5 kgf-m, 11 ft-lb).
 - (6) Tighten all bolts by 80 to 90° in alphabetical sequence.

CAUTION:

Do not tighten bolts more than 90°.

- (7) Further tighten all bolts by 80 to 90° in alphabetical sequence shown in figure below.

CAUTION:

Ensure that the total “re-tightening angle” [in the former two steps], do not exceed 180°.

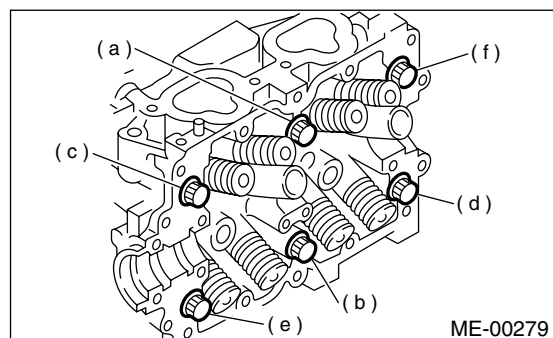

- 3) Install camshaft. <Ref. to ME(H4SO)-57, INSTALLATION, Camshaft.>
- 4) Install valve rocker assembly. <Ref. to ME(H4SO)-54, INSTALLATION, Valve Rocker Assembly.>

CYLINDER HEAD ASSEMBLY

MECHANICAL

- 5) Install A/C compressor bracket on cylinder head.
- 6) Install intake manifold. <Ref. to FU(H4SO)-18, INSTALLATION, Intake Manifold.>
- 7) Install camshaft sprocket. <Ref. to ME(H4SO)-52, INSTALLATION, Camshaft Sprocket.>
- 8) Install timing belt assembly. <Ref. to ME(H4SO)-48, INSTALLATION, Timing Belt Assembly.>
- 9) Install belt cover. <Ref. to ME(H4SO)-46, INSTALLATION, Belt Cover.>
- 10) Install crankshaft pulley. <Ref. to ME(H4SO)-45, INSTALLATION, Crankshaft Pulley.>
- 11) Install V-belt. <Ref. to ME(H4SO)-43, INSTALLATION, V-belt.>

C: DISASSEMBLY

- 1) Place cylinder head on ST.
ST 498267800 CYLINDER HEAD TABLE
- 2) Set ST on valve spring. Compress valve spring and remove the valve spring retainer key. Remove each valve and valve spring.
ST 499718000 VALVE SPRING REMOVER

NOTE:

- Mark each valve to prevent confusion.
- Use extreme care not to damage the lips of the intake valve oil seals and exhaust valve oil seals.

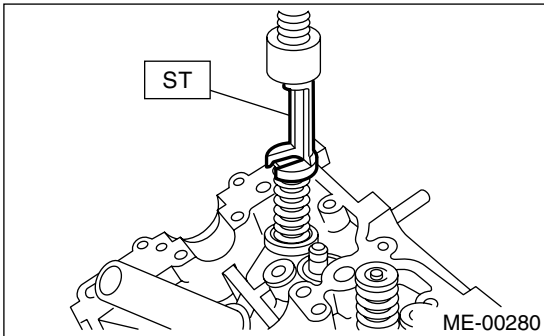

D: ASSEMBLY

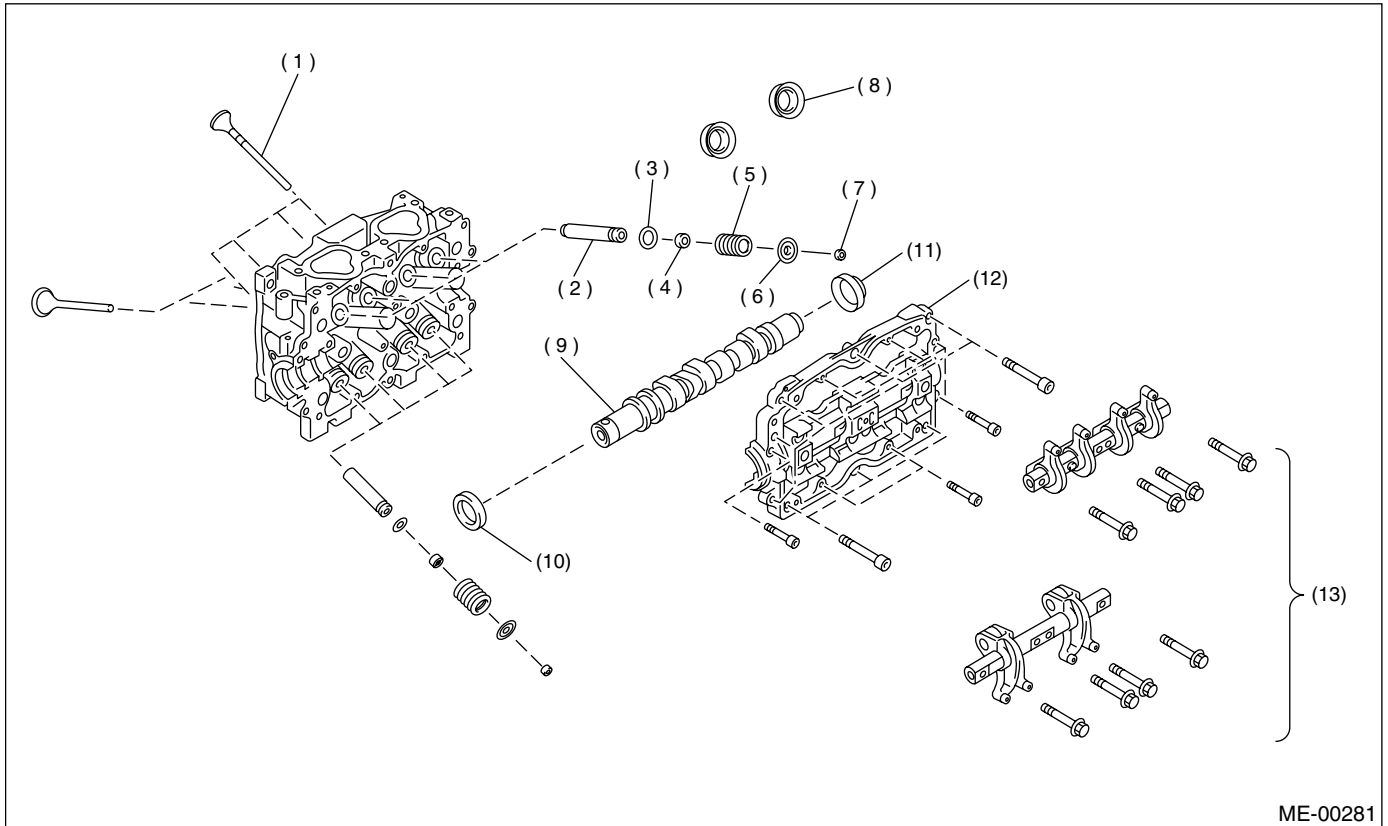

ME-00281

- | | | |
|-----------------------|----------------------------|------------------------|
| (1) Valve | (6) Retainer | (11) Plug |
| (2) Valve guide | (7) Collet (valve) | (12) Camshaft cap |
| (3) Valve spring seat | (8) Spark plug pipe gasket | (13) Valve rocker ASSY |
| (4) Oil seal | (9) Camshaft | |
| (5) Valve spring | (10) Oil seal | |

1) Installation of valve spring and valve

(1) Place cylinder head on ST.

ST 498267800 CYLINDER HEAD TABLE

(2) Coat stem of each valve with engine oil and insert valve into valve guide.

NOTE:

When inserting valve into valve guide, use special care not to damage the oil seal lip.

(3) Install valve spring and retainer.

NOTE:

Be sure to install the valve springs with their close-coiled end facing the seat on the cylinder head.

(4) Set ST on valve spring.

ST 499718000 VALVE SPRING REMOVER

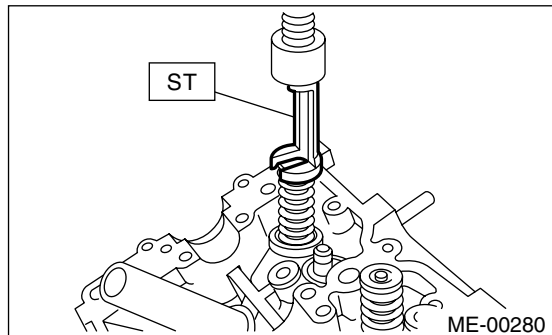

ME-00280

CYLINDER HEAD ASSEMBLY

MECHANICAL

(5) Compress valve spring and fit collet (valve).

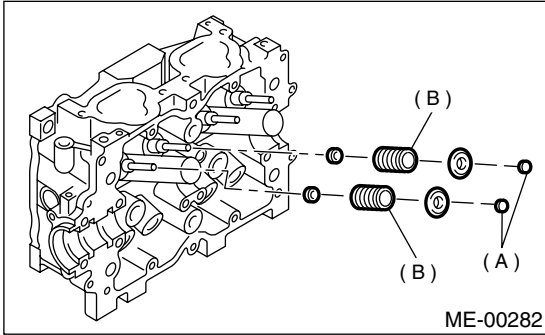

(A) Collet (valve)

(B) Painted face

(6) After installing, tap valve spring retainers lightly with wooden hammer for better seating.

E: INSPECTION

1. VALVE SPRING

1) Check valve springs for damage, free length, and tension. Replace valve spring if it is not to the specifications presented below.

2) To measure the squareness of the valve spring, stand the spring on a surface plate and measure its deflection at the top using a try square.

Free length	54.30 mm (2.1378 in)
Squareness	2.5°, 2.4 mm (0.094 in)
Tension/spring height	214 — 246 N (21.8 — 25.1 kgf, 48.1 — 55.3 lb)/ 45.0 mm (1.772 in)
	526 — 582 N (53.7 — 59.4 kgf, 118.2 — 130.8 lb)/ 34.7 mm (1.366 in)

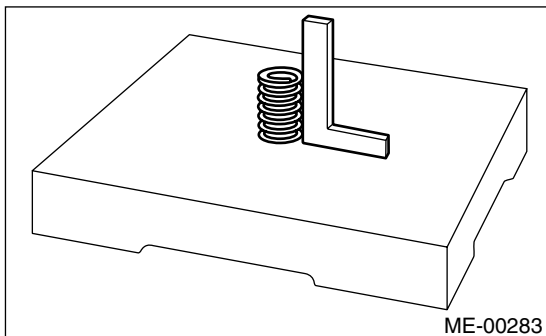

2. INTAKE AND EXHAUST VALVE OIL SEAL

If following conditions are found, use pliers to pinch oil seal and remove it from valve, and replace it new one.

- Lip is damaged
- Spring out of place
- Reconditioning of surfaces for valve and valve seat is necessary
- Replacement of valve guide is necessary

1) Place cylinder head on ST1.

2) Press-fit oil seal to the specified dimension indicated in the figure using ST2.

CAUTION:

- **Apply engine oil to oil seal before press-fitting.**
- **When press-fitting oil seal, do not use hammer or strike in.**
- **Differentiate between intake valve oil seal and exhaust valve oil seal by noting their difference in color.**

ST1 498267800 CYLINDER HEAD TABLE

ST2 498857100 VALVE OIL SEAL GUIDE

Color of rubber part:

Intake [Black]

Exhaust [Brown]

Color of spring part:

Intake [Silver]

Exhaust [Silver]

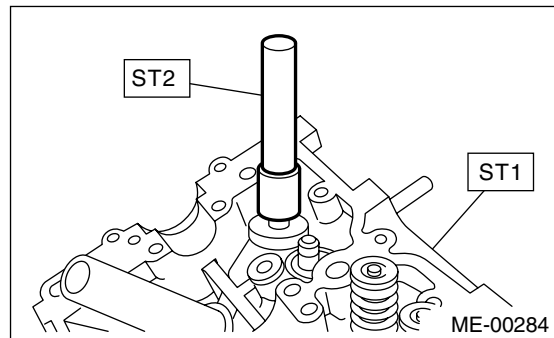

F: ADJUSTMENT

1. CYLINDER HEAD

1) Make sure that no crack or other damage exists. In addition to visual inspection, inspect important areas by means of red lead check.

Also make sure that gasket installing surface shows no trace of gas and water leaks.

2) Place cylinder head on ST.

ST 498267800 CYLINDER HEAD TABLE

3) Measure the warping of the cylinder head surface that mates with crankcase using a straight edge and thickness gauge.

If the warping exceeds 0.05 mm (0.0020 in), re-grind the surface with a surface grinder.

Warping limit:

0.05 mm (0.0020 in)

Grinding limit:

0.1 mm (0.004 in)

Standard height of cylinder head:

97.5 mm (3.839 in)

NOTE:

Uneven torque for the cylinder head bolts can cause warping. When reassembling, pay special attention to the torque so as to tighten evenly.

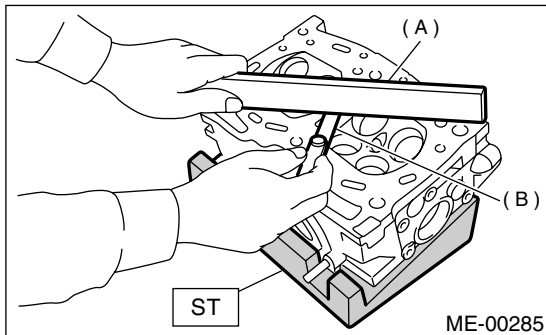

- (A) Straight edge
- (B) Thickness gauge

2. VALVE SEAT

Inspect intake and exhaust valve seats, and correct the contact surfaces with valve seat cutter if they are defective or when valve guides are replaced.

Valve seat width: W

Intake (A)

Standard 1.1 mm (0.043 in)

Limit 1.8 mm (0.071 in)

Exhaust (B)

Standard 1.5 mm (0.059 in)

Limit 2.2 mm (0.087 in)

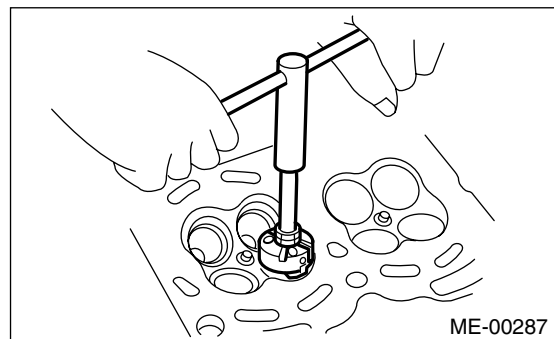
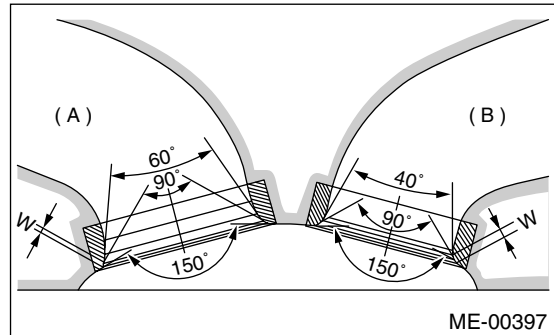

CYLINDER HEAD ASSEMBLY

MECHANICAL

3. VALVE GUIDE

1) Check the clearance between valve guide and stem. The clearance can be checked by measuring the outside diameter of valve stem and the inside diameter of valve guide with outside and inside micrometers respectively.

Clearance between the valve guide and valve stem:

Standard

Intake 0.035 — 0.062 mm (0.0014 — 0.0024 in)

Exhaust 0.040 — 0.067 mm (0.0016 — 0.0026 in)

Limit

0.15 mm (0.0059 in)

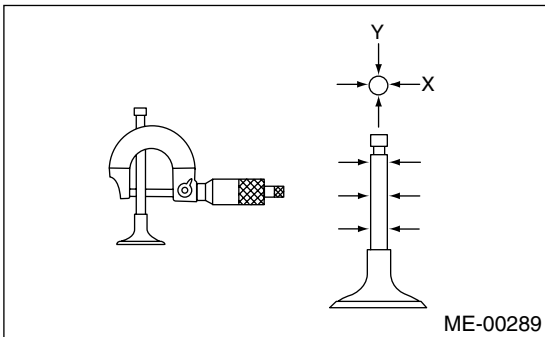
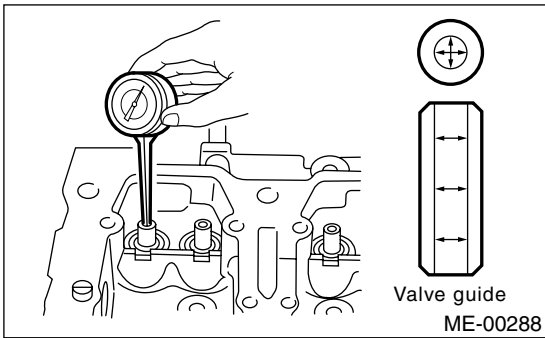

2) If the clearance between valve guide and stem exceeds the limit, replace valve guide or valve itself whichever shows greater amount of wear. See following procedure for valve guide replacement.

Valve guide inner diameter:

6.000 — 6.012 mm (0.2362 — 0.2367 in)

Valve stem outer diameters:

Intake

5.950 — 5.965 mm (0.2343 — 0.2348 in)

Exhaust

5.945 — 5.960 mm (0.2341 — 0.2346 in)

(1) Place cylinder head on ST1 with the combustion chamber upward so that valve guides enter the holes in ST1.

(2) Insert ST2 into valve guide and press it down to remove valve guide.

ST1 498267800 CYLINDER HEAD TABLE
ST2 499767200 VALVE GUIDE REMOVER

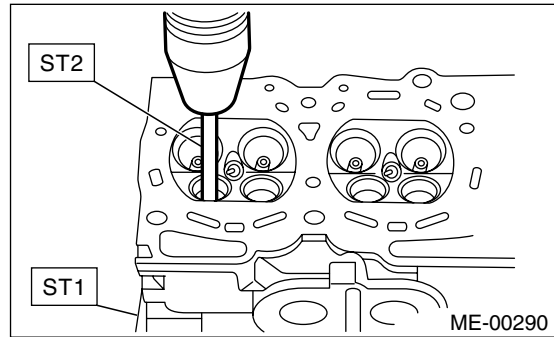

(3) Turn cylinder head upside down and place ST as shown in the figure.

Intake side:

ST 499767700 VALVE GUIDE ADJUSTER

Exhaust side:

ST 499767800 VALVE GUIDE ADJUSTER

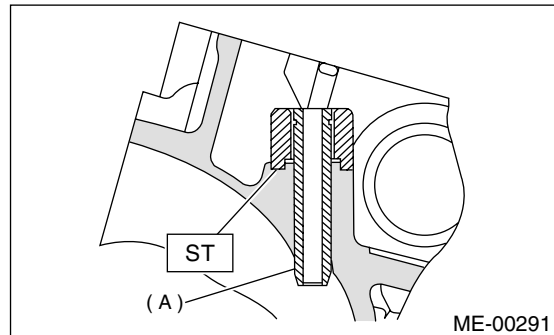

(A) Valve guide

(4) Before installing new oversize valve guide, make sure that neither scratches nor damages exist on the inside surface of the valve guide holes in cylinder head.

(5) Put new valve guide, coated with sufficient oil, in cylinder, and insert ST1 into valve guide. Press in until the valve guide upper end is flush with the upper surface of ST2.

- ST1 499767200 VALVE GUIDE REMOVER
 Intake side:
 ST2 499767700 VALVE GUIDE ADJUSTER
 Exhaust side:
 ST2 499767800 VALVE GUIDE ADJUSTER

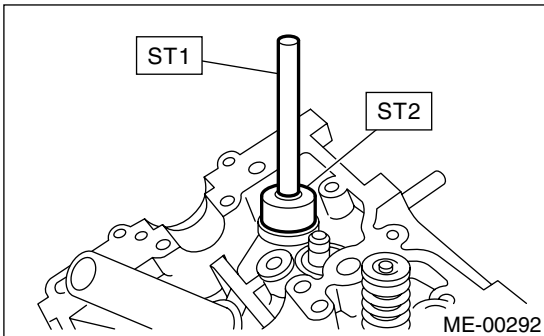

(6) Check the valve guide protrusion.

Valve guide protrusion: L

Intake

20.0 — 20.5 mm (0.787 — 0.807 in)

Exhaust

16.5 — 17.0 mm (0.650 — 0.669 in)

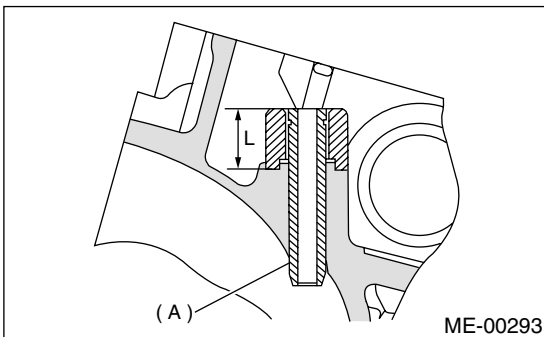

(A) Valve guide

(7) Ream the inside of valve guide with ST. Slowly rotate the reamer clockwise while pressing it lightly into valve guide, and return it also rotating clockwise. After reaming, clean valve guide to remove chips.

NOTE:

- Apply engine oil to the reamer when reaming.
- If the inner surface of the valve guide is torn, the edge of the reamer should be slightly ground with an oil stone.
- If the inner surface of the valve guide becomes lustrous and the reamer does not chips, use a new reamer or remedy the reamer.

- ST 499767400 VALVE GUIDE REAMER

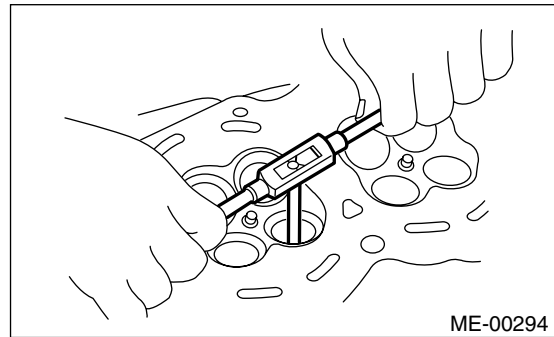

(8) Recheck the contact condition between valve and valve seat after replacing valve guide.

CYLINDER HEAD ASSEMBLY

MECHANICAL

4. INTAKE AND EXHAUST VALVE

1) Inspect the flange and stem of valve, and replace if damaged, worn, or deformed, or if "H" is less than the specified limit.

H:

Intake

Standard 1.0 mm (0.039 in)

Limit 0.6 mm (0.024 in)

Exhaust

Standard 1.2 mm (0.047 in)

Limit 0.6 mm (0.024 in)

Valve overall length:

Intake

120.6 mm (4.75 in)

Exhaust

121.7 mm (4.79 in)

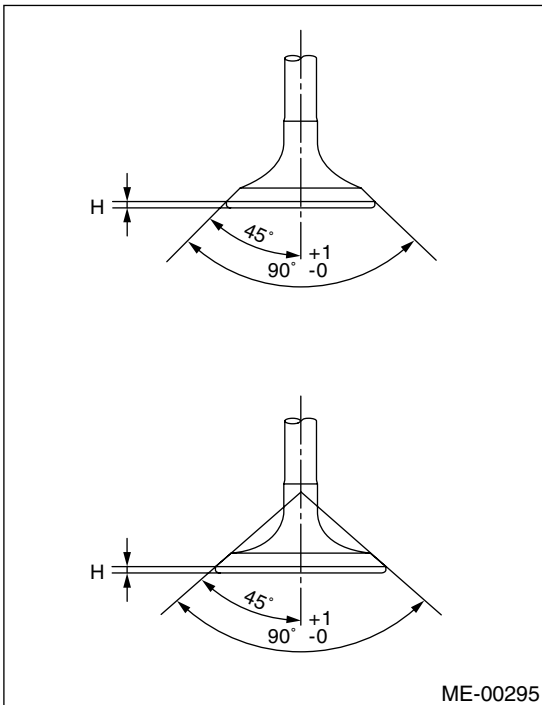

2) Put a small amount of grinding compound on the seat surface and lap the valve and seat surface. <Ref. to ME(H4SO)-65, VALVE SEAT, ADJUSTMENT, Cylinder Head Assembly.> Install a new intake valve oil seal after lapping.

21. Cylinder Block

A: REMOVAL

NOTE:

Before conducting this procedure, drain engine oil completely.

- 1) Remove intake manifold. <Ref. to FU(H4SO)-15, REMOVAL, Intake Manifold.>
- 2) Remove V-belt. <Ref. to ME(H4SO)-43, REMOVAL, V-belt.>
- 3) Remove crankshaft pulley. <Ref. to ME(H4SO)-45, REMOVAL, Crankshaft Pulley.>
- 4) Remove belt cover. <Ref. to ME(H4SO)-46, REMOVAL, Belt Cover.>
- 5) Remove timing belt assembly. <Ref. to ME(H4SO)-47, REMOVAL, Timing Belt Assembly.>
- 6) Remove camshaft sprocket. <Ref. to ME(H4SO)-52, REMOVAL, Camshaft Sprocket.>
- 7) Remove crankshaft sprocket. <Ref. to ME(H4SO)-45, REMOVAL, Crankshaft Pulley.>
- 8) Remove generator and A/C compressor with their brackets.
- 9) Remove rocker cover.
- 10) Remove cylinder head bolts in alphabetical sequence shown in figure.

NOTE:

Leave bolts (a) and (b) engaged by three or four threads to prevent cylinder head from falling.

- 11) While tapping cylinder head with a plastic hammer, separate it from cylinder block.
- 12) Remove bolts (a) through (c) to remove cylinder head.

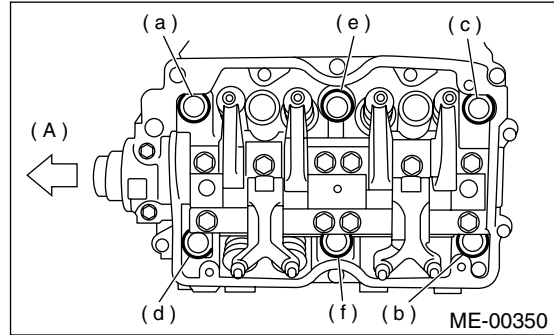

(A) Front side

- 13) Remove cylinder head gasket.

NOTE:

Do not scratch the mating surface of cylinder head and cylinder block.

- 14) Similarly, remove right side cylinder head.
- 15) Remove clutch housing cover (MT vehicles only).
- 16) Remove flywheel (MT vehicles only) or drive plate (AT vehicles only).

Using ST, lock crankshaft.

ST 498497100 CRANKSHAFT STOPPER

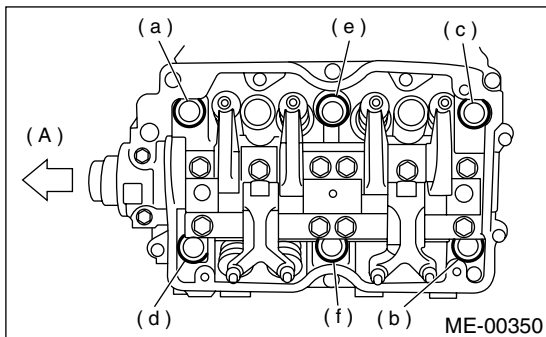

(A) Front side

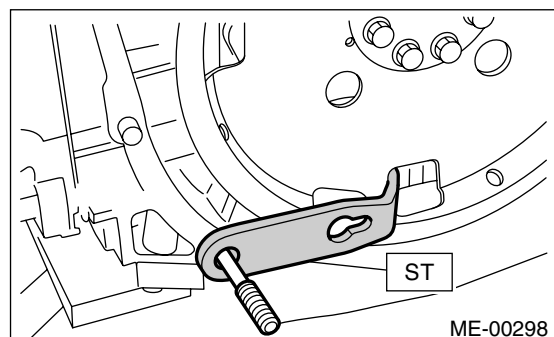
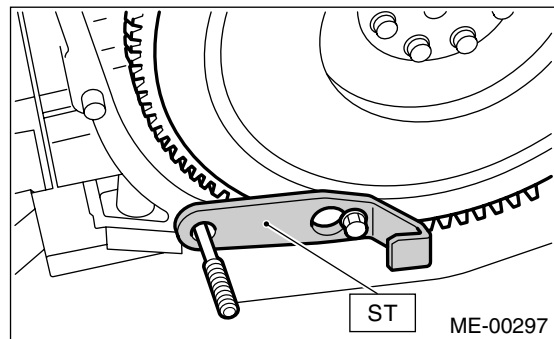

CYLINDER BLOCK

MECHANICAL

- 17) Remove oil separator cover.
- 18) Remove water by-pass pipe for heater.
- 19) Loosen bolts in alphabetical sequence as shown in figure and remove water pump.

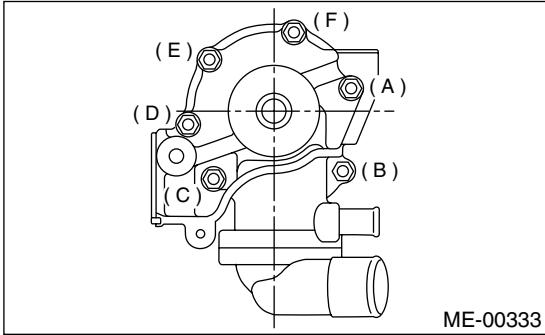

- 20) Remove oil pump from cylinder block.
Use a flat-bladed screwdriver as shown in figure when removing oil pump.

NOTE:

Be careful not to scratch the mating surface of cylinder block and oil pump.

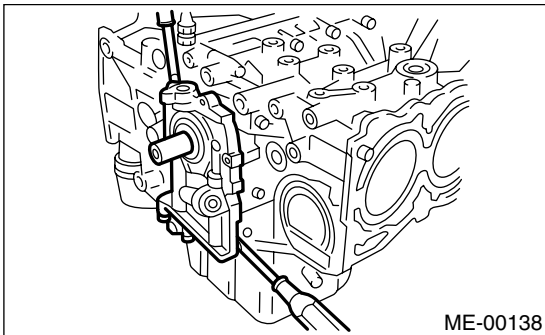

- 21) Removal of oil pan
 - (1) Turn cylinder block with #2 and #4 piston sides facing upward.
 - (2) Remove bolts which secure oil pan to cylinder block.
 - (3) Insert a oil pan cutter blade between cylinder block-to-oil pan clearance and remove oil pan.

NOTE:

Do not use a screwdriver or similar tool in place of oil pan cutter.

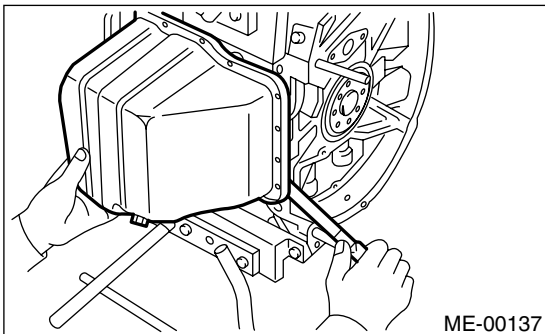

- 22) Remove oil strainer stay.
- 23) Remove oil strainer.
- 24) Remove baffle plate.
- 25) Remove oil filter using ST.
 - ST 498547000 OIL FILTER WRENCH [outer diameter 80 mm (3.15 in) for oil filter]
 - ST 18332AA000 OIL FILTER WRENCH [outer diameter 68 mm (2.68 in) for oil filter]
 - ST 18332AA010 OIL FILTER WRENCH [outer diameter 65 mm (2.56 in) for oil filter]

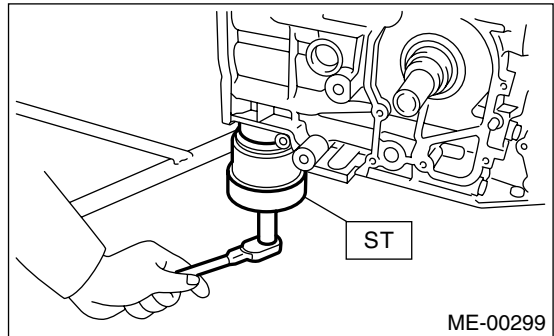

- 26) Remove water pipe.

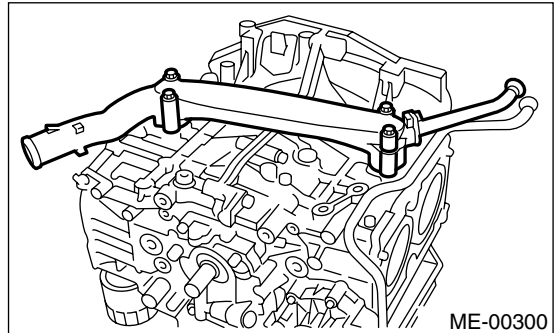

CYLINDER BLOCK

MECHANICAL

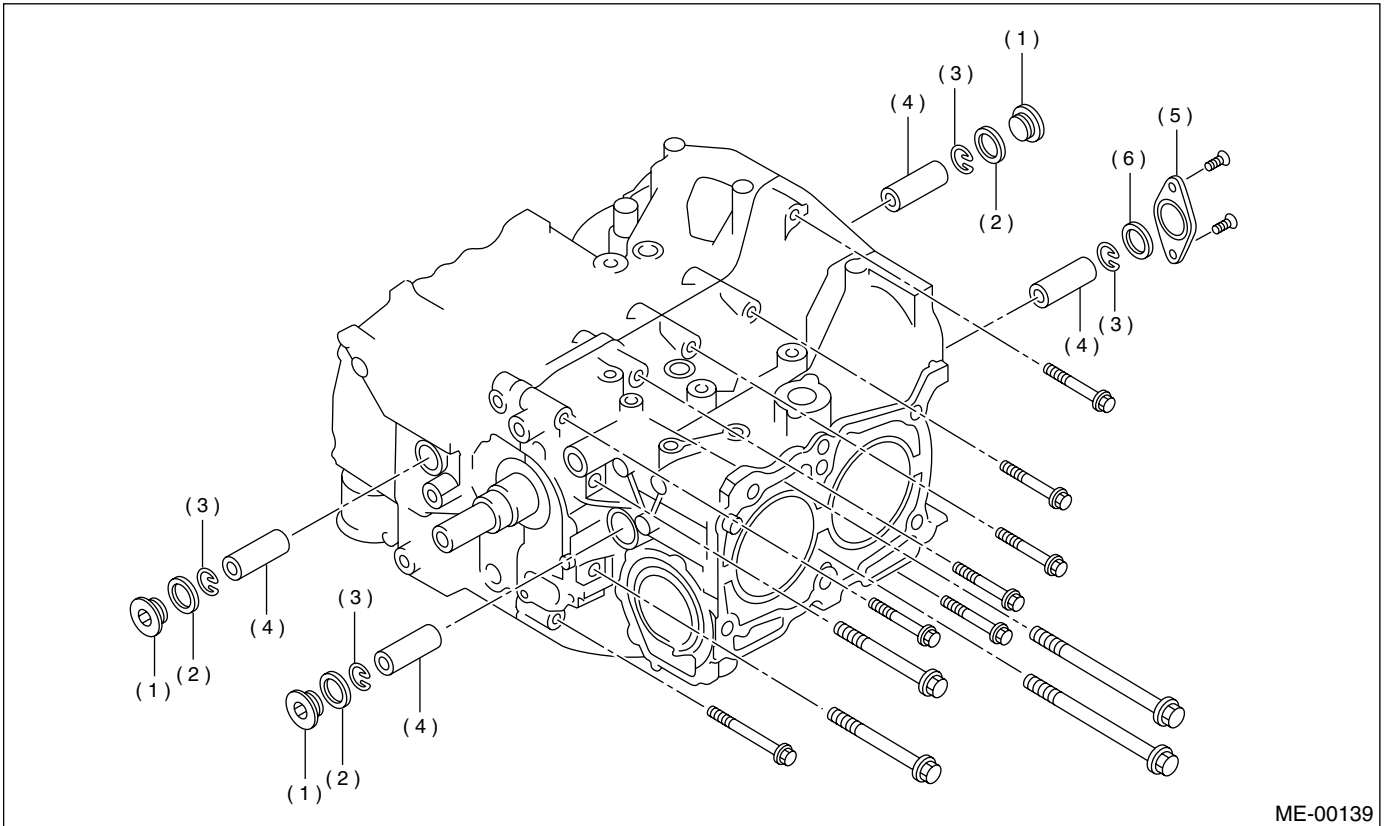

- (1) Service hole plug
- (2) Gasket

- (3) Snap ring
- (4) Piston pin

- (5) Service hole cover
- (6) O-ring

27) Remove service hole cover and service hole plugs using hexagon wrench [14 mm (0.55 in)].

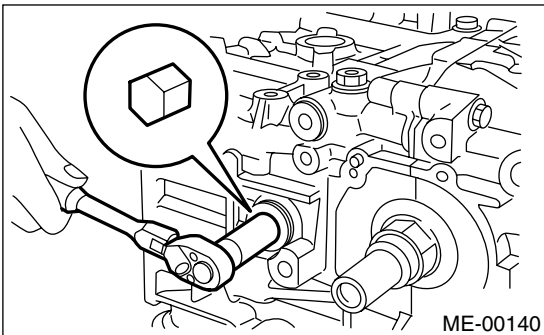

28) Rotate crankshaft to bring #1 and #2 pistons to bottom dead center position, then remove piston snap ring through service hole of #1 and #2 cylinders.

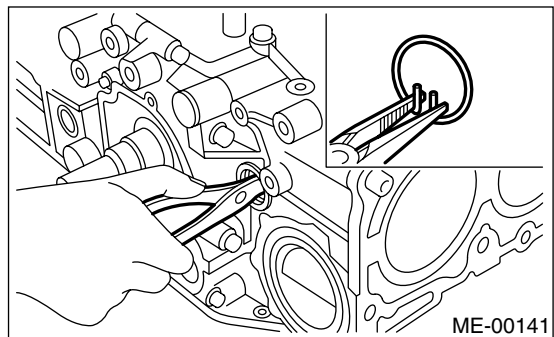

CYLINDER BLOCK

MECHANICAL

29) Draw out piston pin from #1 and #2 pistons using ST.

ST 499097700 PISTON PIN REMOVER

NOTE:

Be careful not to confuse original combination of piston, piston pin and cylinder.

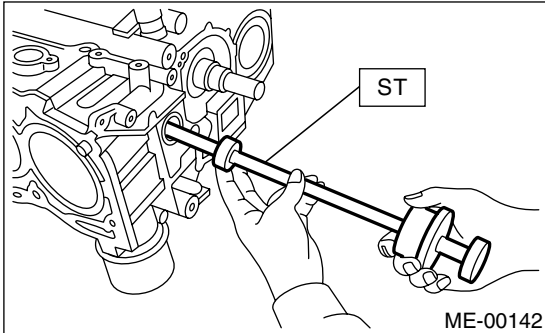

30) Similarly remove piston pins from #3 and #4 pistons.

31) Remove bolts which connect cylinder block on the side of #2 and #4 cylinders.

32) Loosen bolts which connect cylinder block on the side of #1 and #3 cylinders two or three turns.

33) Set up cylinder block so that #1 and #3 cylinders are on the upper side, then remove cylinder block connecting bolts.

34) Separate left-hand and right-hand cylinder blocks.

NOTE:

When separating cylinder block, do not allow the connecting rod to fall and damage the cylinder block.

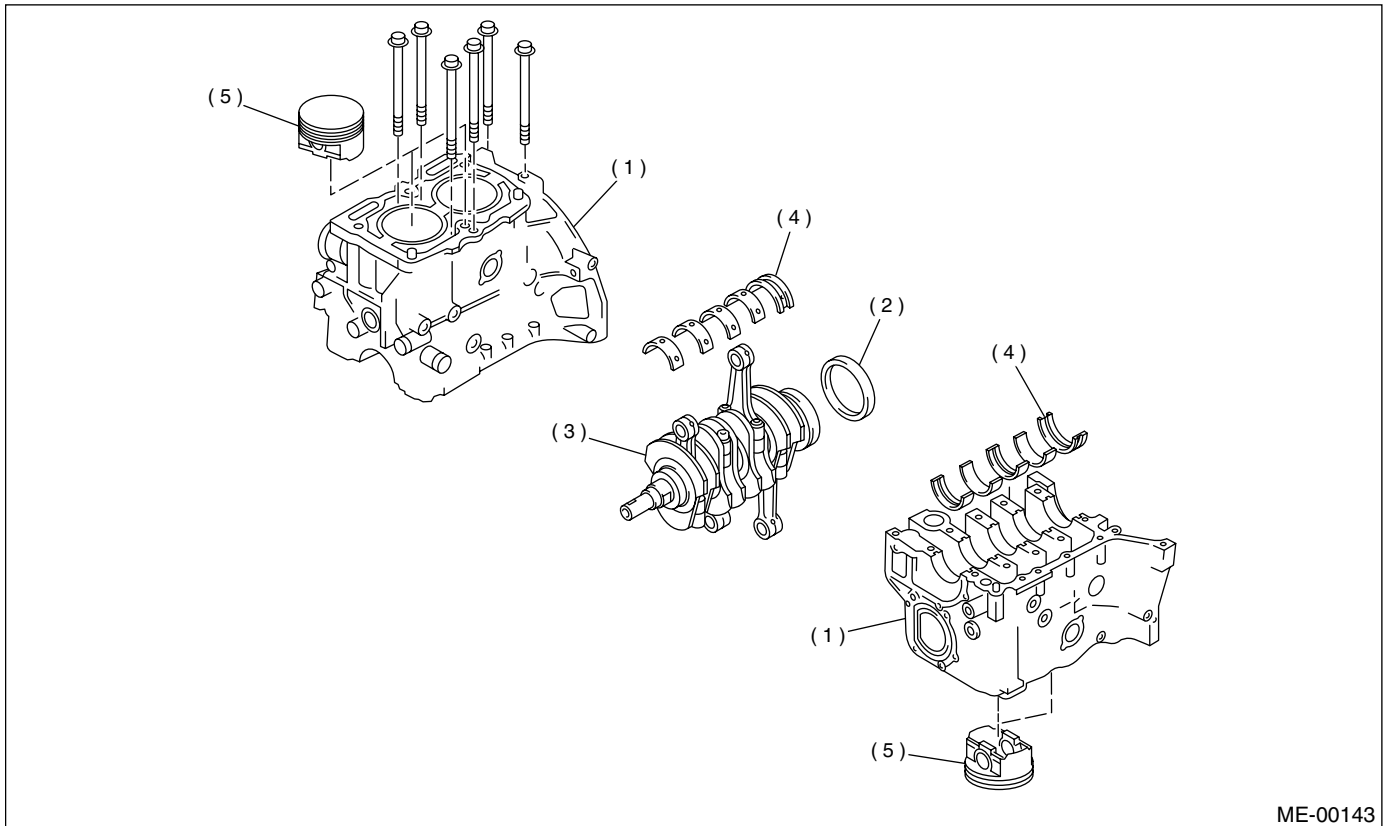

(1) Cylinder block

(2) Rear oil seal

(3) Crankshaft

(4) Crankshaft bearing

(5) Piston

- 35) Remove rear oil seal.
- 36) Remove crankshaft together with connecting rod.
- 37) Remove crankshaft bearings from cylinder block using hammer handle.

NOTE:

Do not confuse combination of crankshaft bearings. Press bearing at the end opposite to locking lip.

- 38) Remove pistons from cylinder block using hammer handle.

NOTE:

Do not confuse combination of pistons and cylinders.

B: INSTALLATION

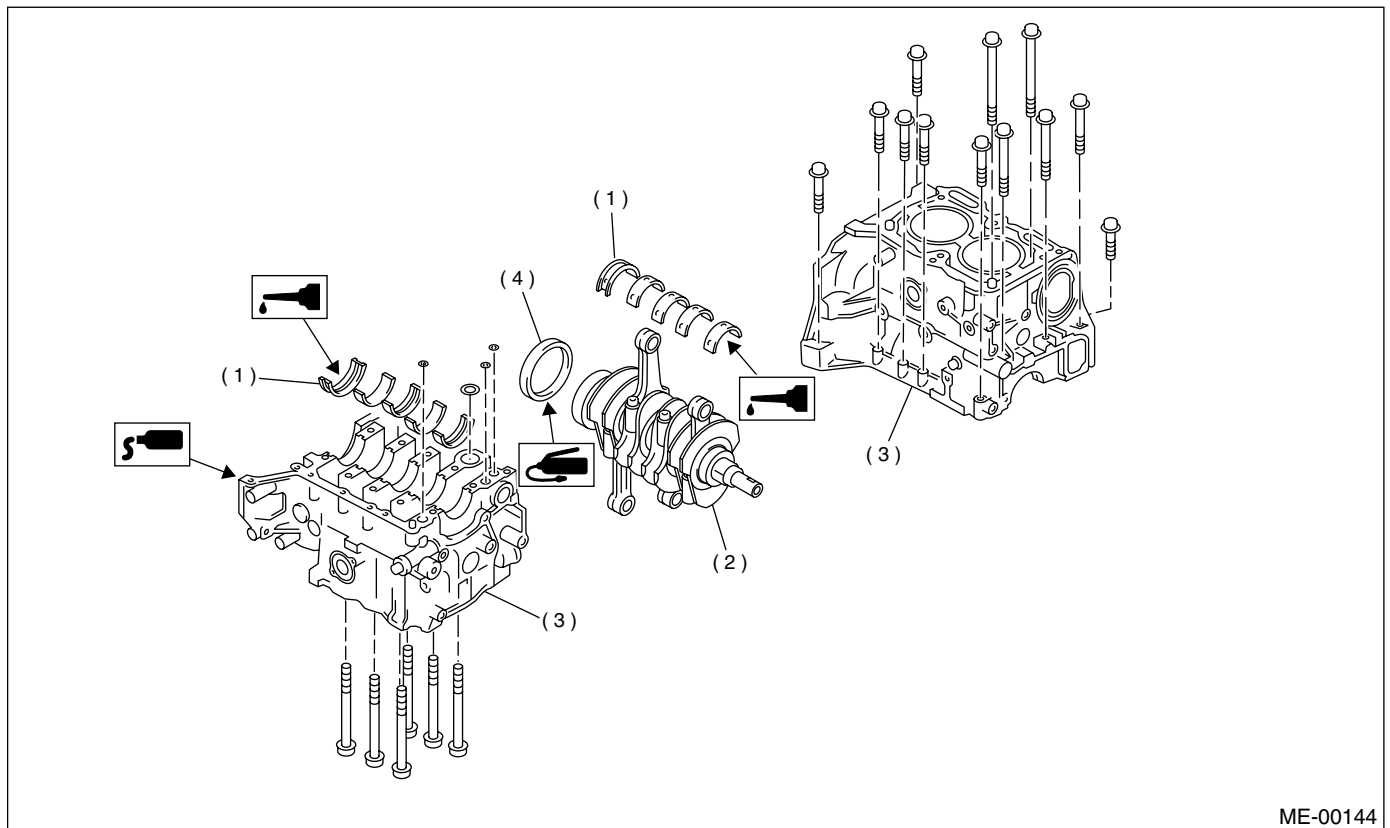

ME-00144

- (1) Crankshaft bearing
- (2) Crankshaft
- (3) Cylinder block
- (4) Rear oil seal

NOTE:

Remove oil in the mating surface of bearing and cylinder block before installation. Also apply a coat of engine oil to crankshaft pins.

- 1) Position crankshaft on the #2 and #4 cylinder block.
- 2) Apply fluid packing to the mating surface of #1 and #3 cylinder block, and position it on #2 and #4 cylinder block.

Fluid packing:

Part number 004403007

THREE BOND 1215 or equivalent

CYLINDER BLOCK

MECHANICAL

NOTE:

Do not allow fluid packing to jut into O-ring grooves, oil passages, bearing grooves, etc.

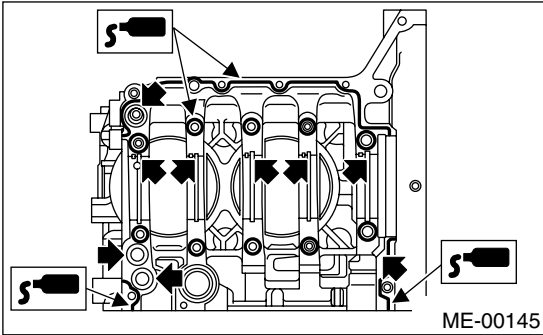

3) Tighten 10 mm cylinder block connecting bolts in alphabetical sequence shown in figure. (LH side)

Tightening torque:

15 N·m (1.5 kgf-m, 11 ft-lb)

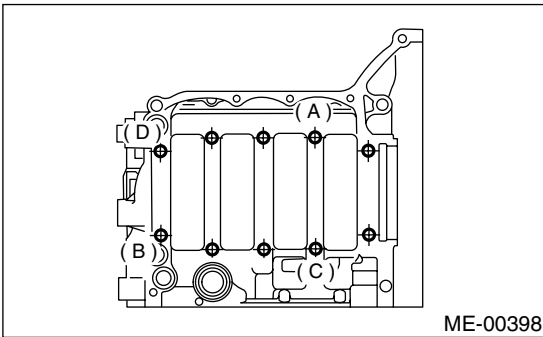

4) Tighten 10 mm cylinder block connecting bolts in alphabetical sequence shown in figure. (RH side)

Tightening torque:

15 N·m (1.5 kgf-m, 11 ft-lb)

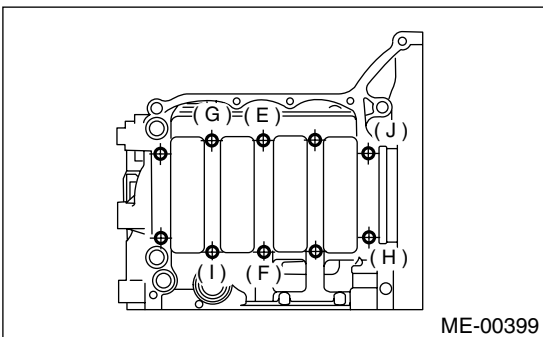

5) Tighten bolts (A to D) on left side of cylinder block more 90° in alphabetical sequence.

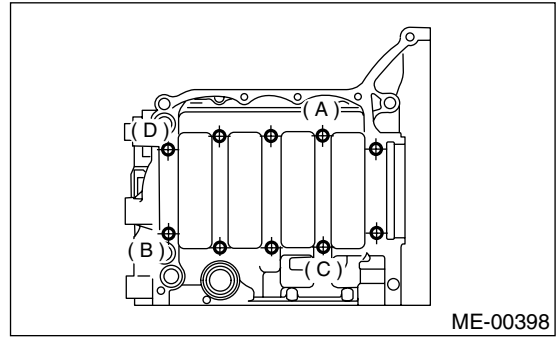

6) Tighten bolts (E to J) on right side of cylinder block more 90° in alphabetical sequence.

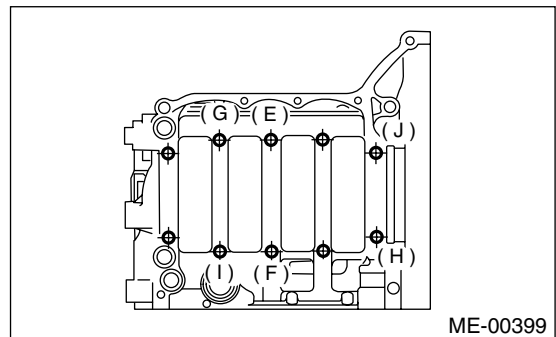

7) Tighten 8 mm and 6 mm cylinder block connecting bolts in alphabetical sequence shown in figure.

Tightening torque:

(A) — (G): 25 N·m (2.5 kgf-m, 18.1 ft-lb)

(H): 6.4 N·m (0.65 kgf-m, 4.7 ft-lb)

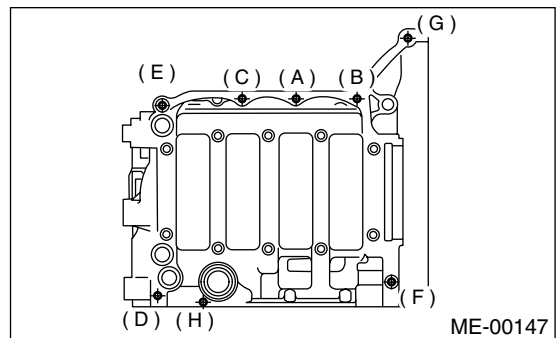

CYLINDER BLOCK

MECHANICAL

8) Install rear oil seal using ST1 and ST2.

ST1 499597100 OIL SEAL GUIDE

ST2 499587200 OIL SEAL INSTALLER

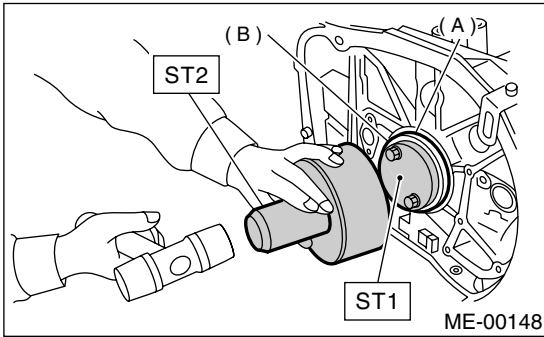

(A) Rear oil seal

(B) Flywheel attaching bolt

9) Position the top ring gap at (A) or (B) in the figure.

10) Position the second ring gap at 180° on the reverse side for the top ring gap.

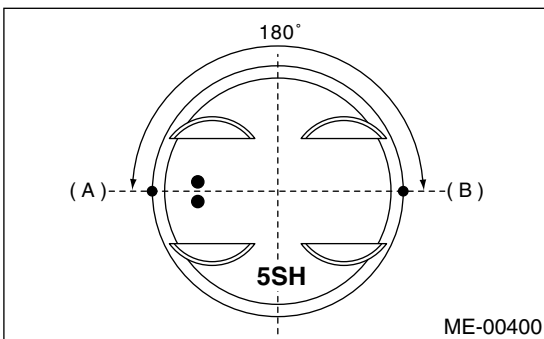

11) Position the expander gap at (C) in the figure. Except U5

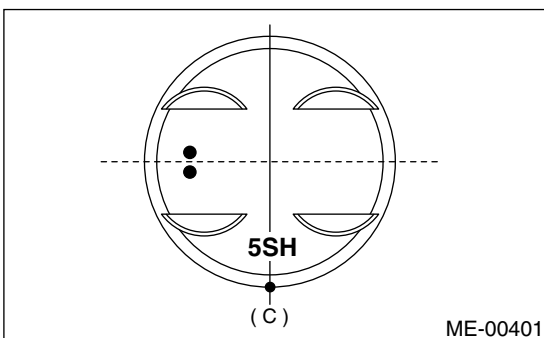

U5

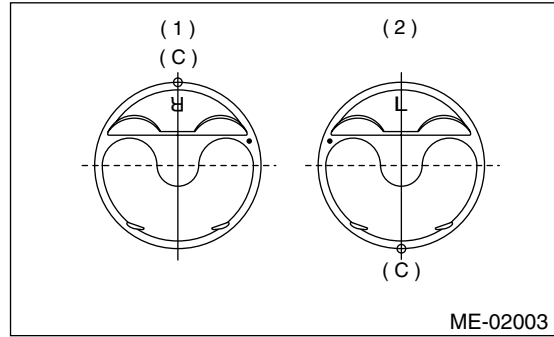

(1) Right side

(2) Left side

12) Position the lower rail gap at (D) in the figure. Except U5

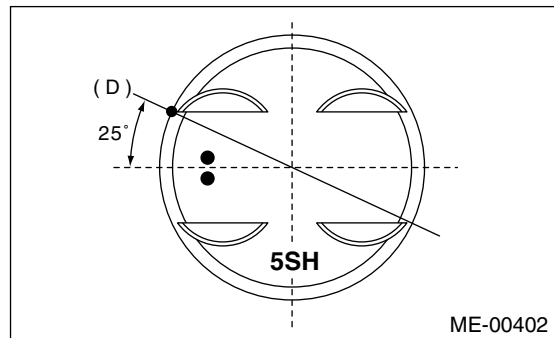

U5

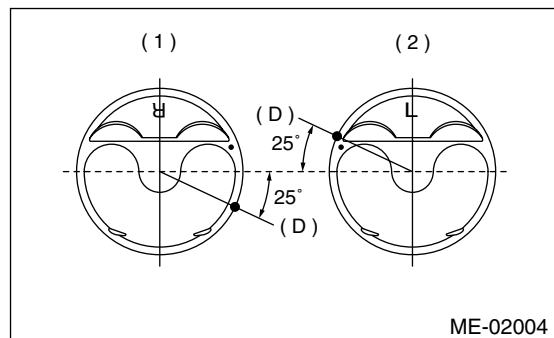

(1) Right side

(2) Left side

CYLINDER BLOCK

MECHANICAL

NOTE:

Align lower rail spin stopper (F) with piston side surface hole (E).

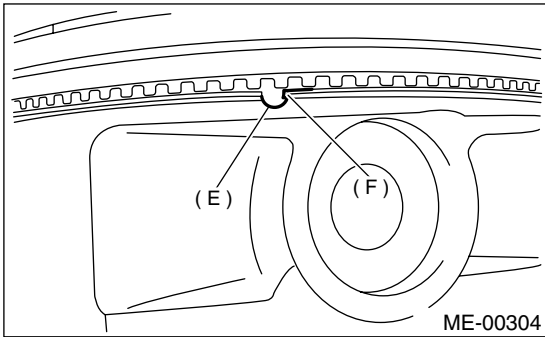

13) Position the upper rail gap at (G) in the figure. Except U5

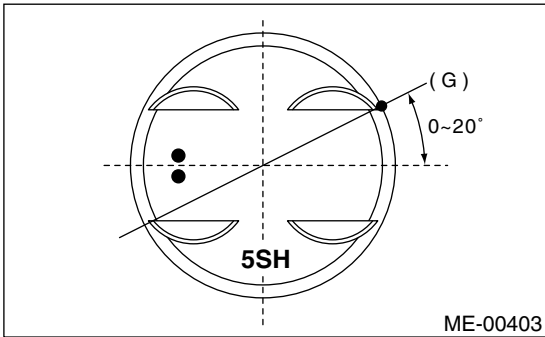

U5

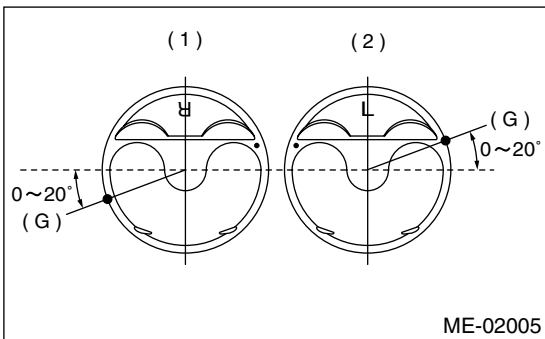

- (1) Right side
- (2) Left side

CAUTION:

- Ensure ring gaps do not face the same direction.
- Ensure ring gaps are not within the piston skirt area.

14) Install snap ring.

Install snap rings in piston holes located opposite service holes in cylinder block, when positioning all pistons in the corresponding cylinders.

NOTE:

Use new snap rings.

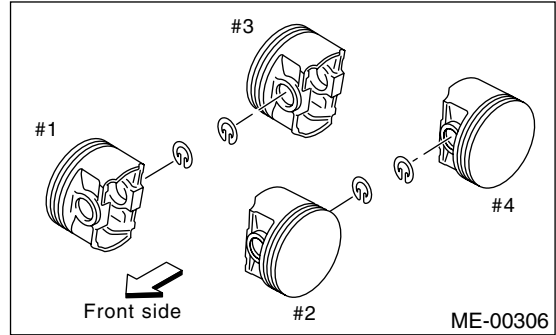

NOTE:

Piston front mark (A) faces towards the front of the engine.

Except U5

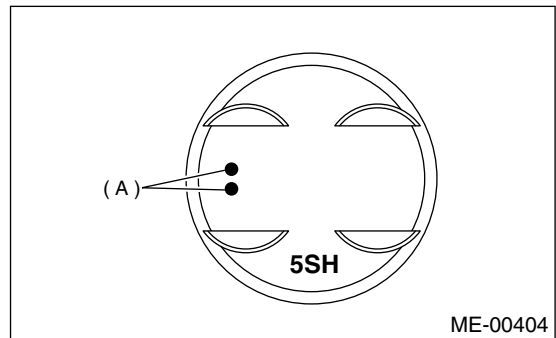

U5

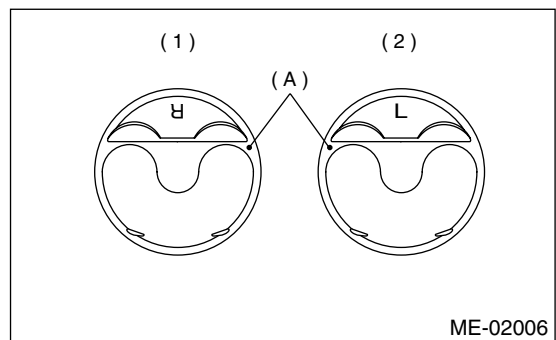

- (1) Right side
- (2) Left side

CYLINDER BLOCK

MECHANICAL

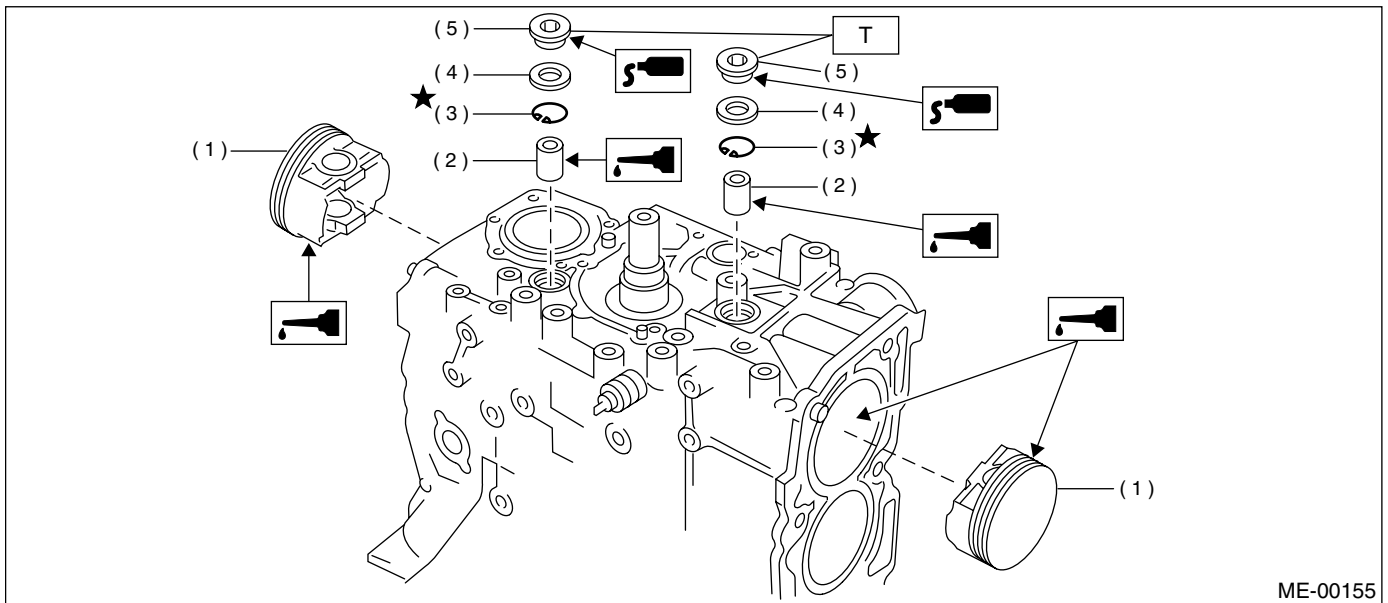

- (1) Piston
- (2) Piston pin
- (3) Snap ring
- (4) Gasket
- (5) Service hole plug

Tightening torque: N·m (kgf·m, ft·lb)
T: 70 (7.1, 51)

15) Installing piston

- (1) Turn cylinder block so that #1 and #2 cylinders face upward.
- (2) Using ST1, turn crankshaft so that #1 and #2 connecting rods are set at bottom dead center.

ST1 499987500 CRANKSHAFT SOCKET

- (3) Apply a coat of engine oil to pistons and cylinders and insert pistons in their cylinders using ST2.

ST2 498747300 PISTON GUIDE

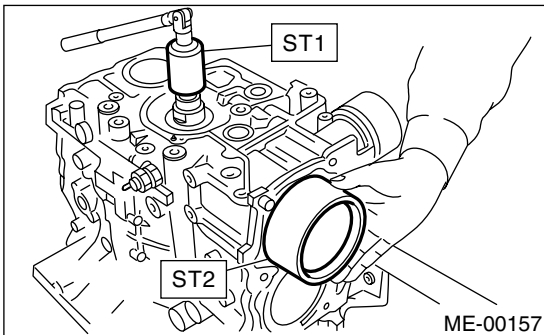

16) Installing piston pin

- (1) Apply a coat of engine oil to ST3.
- (2) Insert ST3 into service hole to align piston pin hole with connecting rod small end.

ST3 499017100 PISTON PIN GUIDE

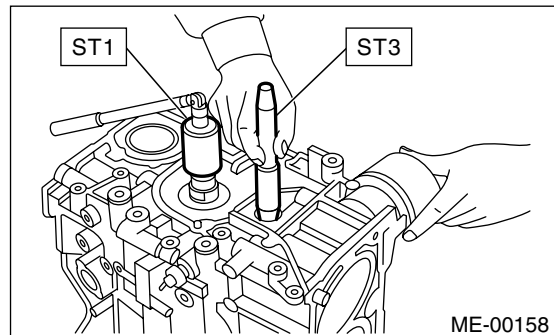

- (3) Apply a coat of engine oil to piston pin and insert piston pin into piston and connecting rod through service hole.

CYLINDER BLOCK

MECHANICAL

(4) Install snap ring.

NOTE:

Use new snap rings.

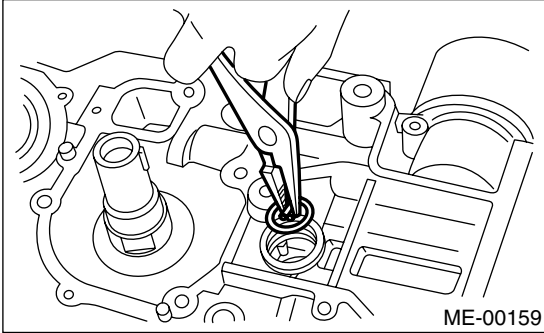

(5) Apply fluid packing around the service hole plug.

Fluid packing:

Part number 004403007

THREE BOND 1215 or equivalent

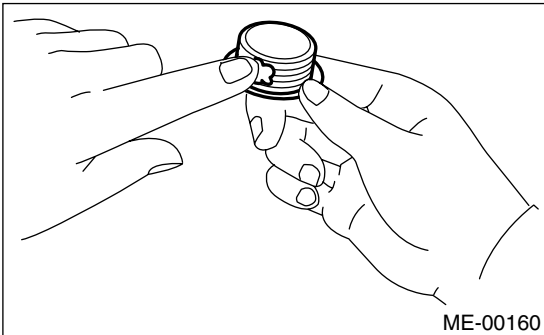

(6) Install service hole plug and gasket.

NOTE:

Use a new gasket.

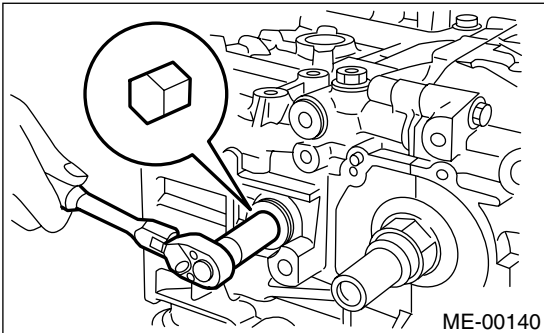

CYLINDER BLOCK

MECHANICAL

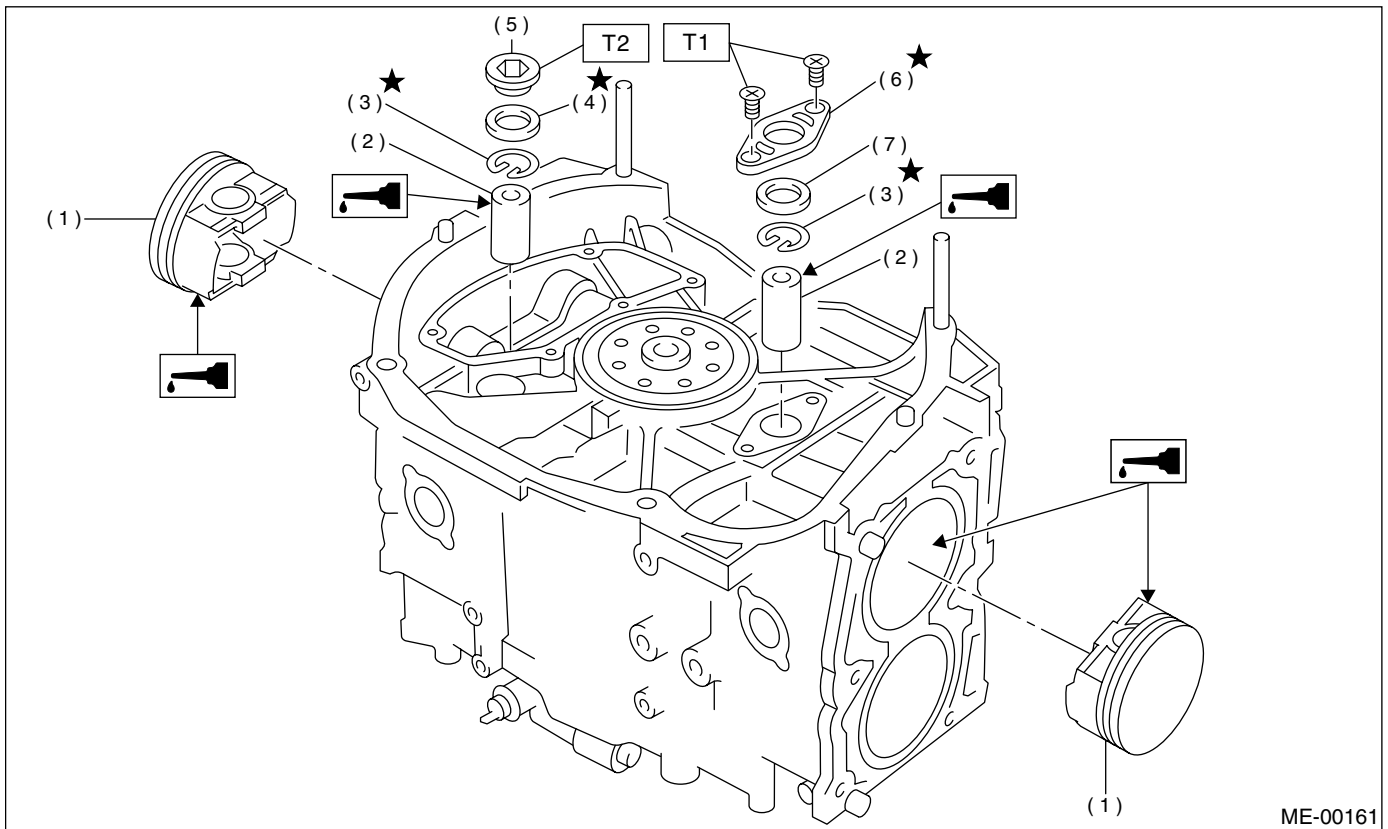

ME-00161

- | | |
|----------------|------------------------|
| (1) Piston | (5) Service hole plug |
| (2) Piston pin | (6) Service hole cover |
| (3) Snap ring | (7) O-ring |
| (4) Gasket | |

Tightening torque: N·m (kgf·m, ft·lb)

T1: 6.4 (0.65, 4.7)

T2: 70 (7.1, 51)

(7) Turn cylinder block so that #3 and #4 cylinders face upward. Using the same procedures as used for #1 and #2 cylinders, install pistons and piston pins.

17) Install water pipe.

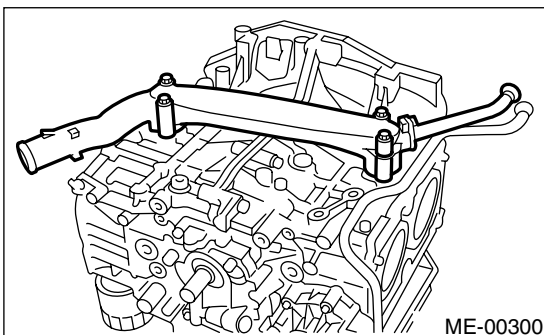

ME-00300

18) Install baffle plate.

Tightening torque:

6.4 N·m (0.65 kgf·m, 4.7 ft·lb)

19) Install oil strainer and O-ring

Tightening torque:

10 N·m (1.0 kgf·m, 7 ft·lb)

20) Install oil strainer stay.

21) Apply fluid packing to matching surfaces and install oil pan.

Fluid packing:

Part number 004403007

THREE BOND 1215 or equivalent

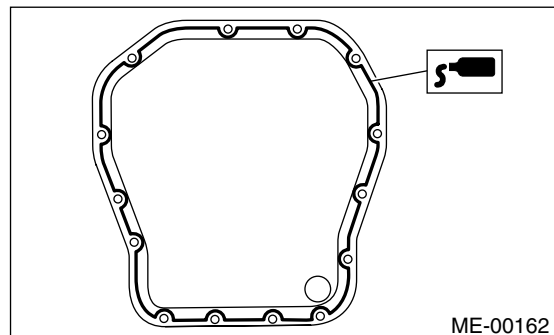

ME-00162

CYLINDER BLOCK

MECHANICAL

22) Apply fluid packing to matching surfaces and install oil separator cover.

Fluid packing:

Part number 004403007

THREE BOND 1215 or equivalent

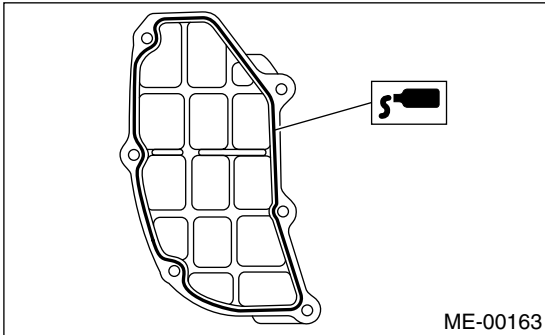

23) Install flywheel or drive plate.

To lock crankshaft, use ST.

ST 498497100 CRANKSHAFT STOPPER

Tightening torque:

72 N·m (7.3 kgf·m, 52.8 ft·lb)

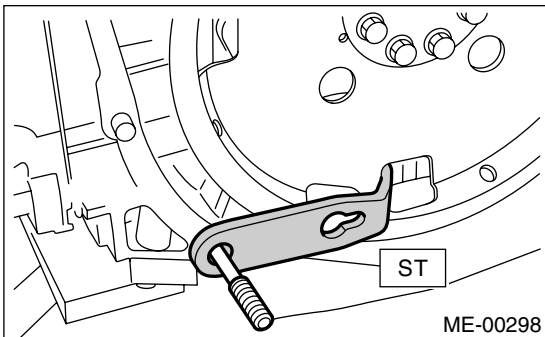
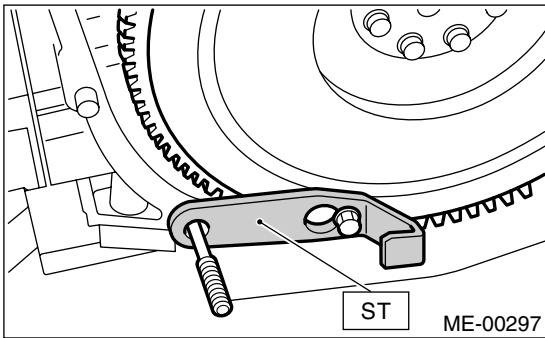

24) Install housing cover.

25) Installation of oil pump

(1) Discard front oil seal after removal. Replace with a new one using ST.

ST 499587100 OIL SEAL INSTALLER

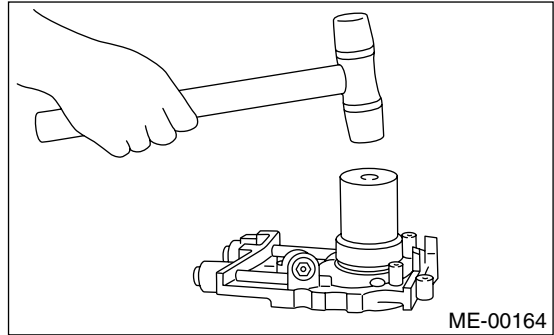

(2) Apply fluid packing to matching surface of oil pump.

Fluid packing:

Part number 004403007

THREE BOND 1215 or equivalent

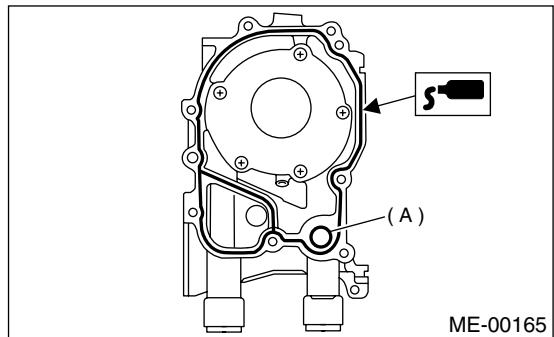

(A) O-ring

(3) Apply a coat of engine oil to the inside of the oil seal.

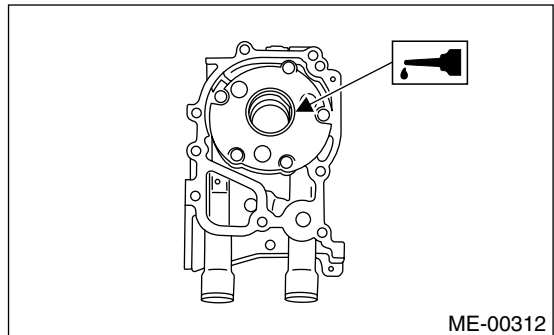

(4) Install oil pump on cylinder block. Be careful not to damage oil seal during installation.

Tightening torque:

6.4 N·m (0.65 kgf·m, 4.7 ft·lb)

NOTE:

- Do not forget to install O-ring and seal when installing oil pump.
- Align flat surface of oil pump's inner rotor with crankshaft before installation.

26) Install water pump and gasket.

Tightening torque:

First; 12 N·m (1.2 kgf-m, 8.7 ft-lb)

Second; 12 N·m (1.2 kgf-m, 8.7 ft-lb)

NOTE:

- Be sure to use a new gasket.
- When installing water pump, tighten bolts in two stages in alphabetical sequence as shown in figure.

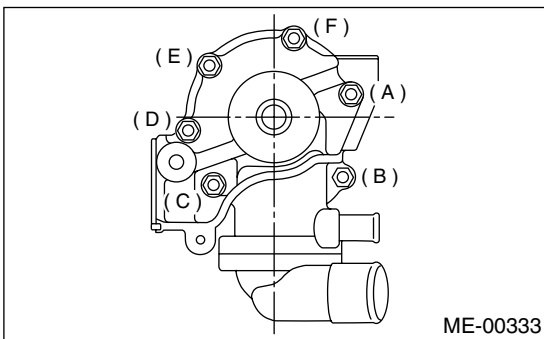

27) Install water by-pass pipe for heater.

28) Install oil filter by turning it by hand, being careful not to damage seal rubber.

- Further tighten (approximately 2/3 to 3/4 turn) the oil filter with outer diameter of 80 mm (3.15 in) after the seal rubber contacts the cylinder block or the oil cooler.
- Further tighten (approximately 1 turn) the oil filter with outer diameter of 68 mm (2.68 in) or 65 mm (2.56 in) after the seal rubber contacts the cylinder block.

CAUTION:

- **Oil filter with outer diameter of 80 mm (3.15 in) is not available for turbo model.**
- **Do not tighten excessively, or oil may leak.**

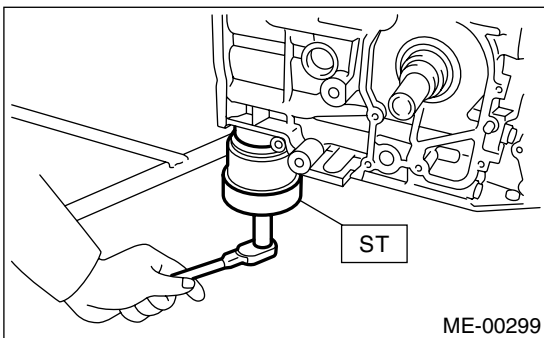

29) Tighten cylinder head bolts.

- (1) Apply a coat of engine oil to washers and bolt threads.

(2) Tighten all bolts to 29 N·m (3.0 kgf-m, 22 ft-lb) in alphabetical sequence.

Then tighten all bolts to 69 N·m (7.0 kgf-m, 51 ft-lb) in alphabetical sequence.

(3) Back off all bolts by 180° first; back them off by 180° again.

(4) Tighten bolts (a) and (b) to 34 N·m (3.5 kgf-m, 25 ft-lb).

(5) Tighten bolts (c), (d), (e) and (f) to 15 N·m (1.5 kgf-m, 11 ft-lb).

(6) Tighten all bolts by 80 to 90° in alphabetical sequence.

CAUTION:

Do not tighten bolts more than 90°.

(7) Further tighten all bolts by 80 to 90° in alphabetical sequence.

CAUTION:

Ensure that the total “re-tightening angle” [in the former two steps], do not exceed 180°.

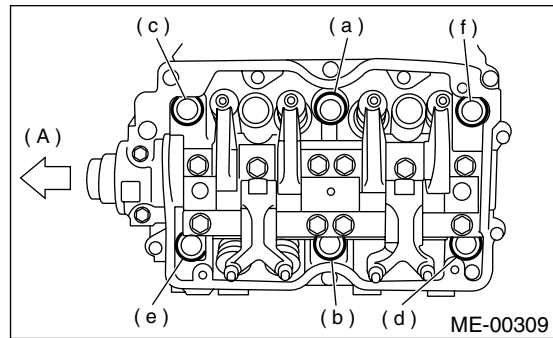

(A) Front side

30) Install oil level gauge guide and tighten attaching bolt (left side only).

31) Install rocker cover.

32) Install crankshaft sprocket. <Ref. to ME(H4SO)-53, INSTALLATION, Crankshaft Sprocket.>

33) Install camshaft sprocket. <Ref. to ME(H4SO)-52, INSTALLATION, Camshaft Sprocket.>

34) Install timing belt assembly. <Ref. to ME(H4SO)-48, INSTALLATION, Timing Belt Assembly.>

35) Install belt cover. <Ref. to ME(H4SO)-46, INSTALLATION, Belt Cover.>

36) Install crankshaft pulley. <Ref. to ME(H4SO)-45, INSTALLATION, Crankshaft Pulley.>

37) Install generator and A/C compressor brackets on cylinder head.

38) Install V-belt. <Ref. to ME(H4SO)-43, INSTALLATION, V-belt.>

39) Install intake manifold. <Ref. to FU(H4SO)-18, INSTALLATION, Intake Manifold.>

CYLINDER BLOCK

MECHANICAL

C: DISASSEMBLY

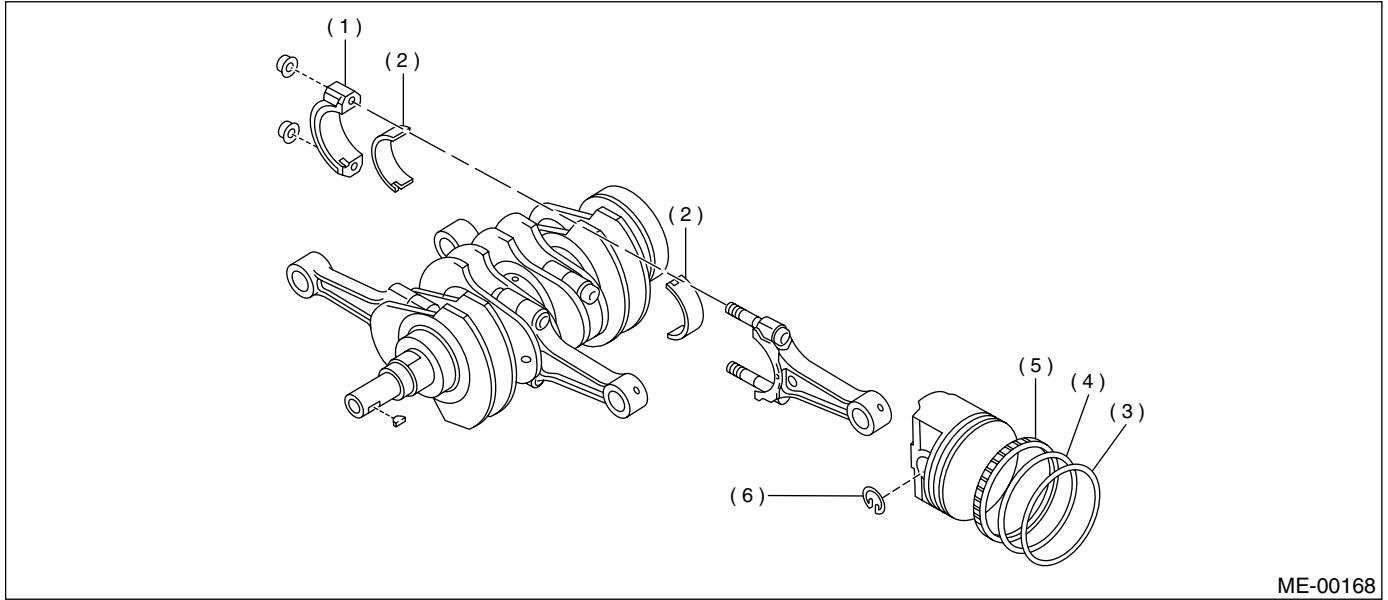

(1) Connecting rod cap
(2) Connecting rod bearing

(3) Top ring
(4) Second ring

(5) Oil ring
(6) Snap ring

- 1) Remove connecting rod cap.
- 2) Remove connecting rod bearing.

NOTE:

Arrange removed connecting rod, connecting rod cap and bearing in order to prevent confusion.

3) Remove piston rings using the piston ring expander.

4) Remove the oil ring by hand.

NOTE:

Arrange the removed piston rings in good order to prevent confusion.

5) Remove snap ring.

D: ASSEMBLY

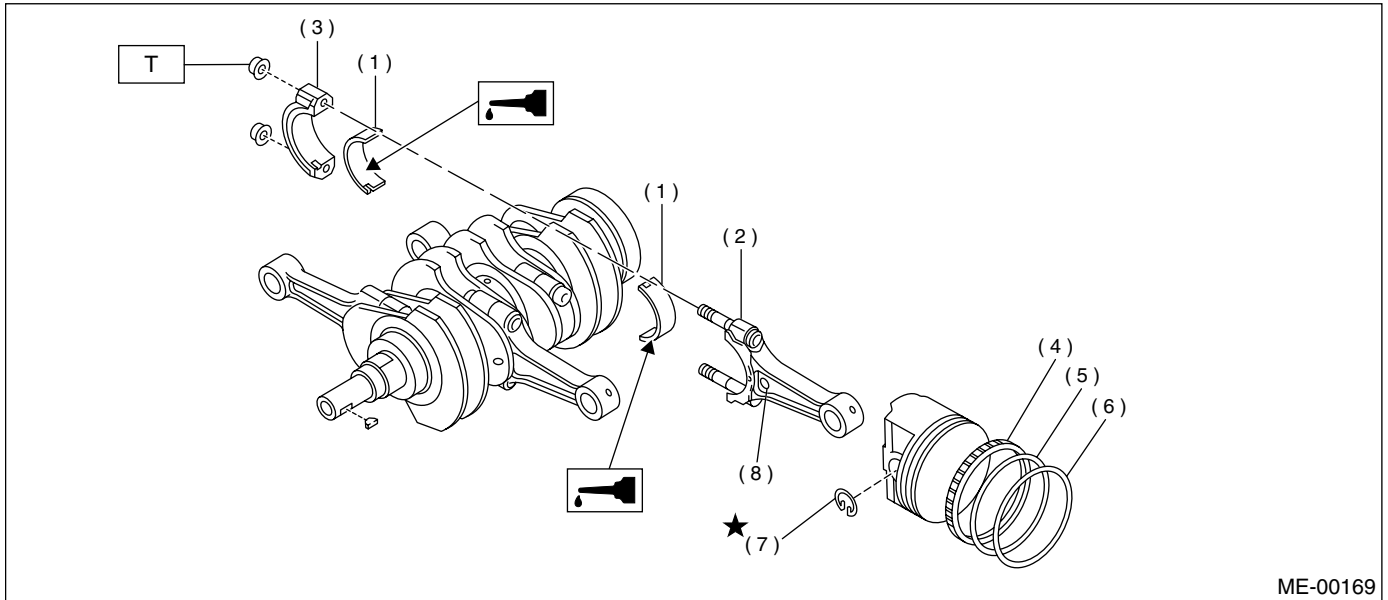

- | | |
|----------------------------|-----------------|
| (1) Connecting rod bearing | (5) Second ring |
| (2) Connecting rod | (6) Top ring |
| (3) Connecting rod cap | (7) Snap ring |
| (4) Oil ring | (8) Side mark |

Tightening torque: N-m (kgf-m, ft-lb)

T: 45 (4.6, 33)

1) Apply oil to the surfaces of the connecting rod bearings.

2) Install connecting rod bearings on connecting rods and connecting rod caps.

3) Position each connecting rod with the side marked facing forward, and install connecting rod on crankshaft.

4) Install connecting rod cap with connecting rod nut.

Ensure the arrow on connecting rod cap faces the front during installation.

NOTE:

- Each connecting rod has its own mating cap. Make sure that they are assembled correctly by checking their matching number.

- When tightening the connecting rod nuts, apply oil on the threads.

5) Install oil ring spacer, lower rail and upper rail in this order by hand. Then install second ring and top ring with a piston ring expander.

E: INSPECTION

1. CYLINDER BLOCK

1) Visually check for cracks and damage. Especially, inspect important parts by means of red lead check.

2) Check the oil passages for clogging.

3) Inspect crankcase surface that mates with cylinder head for warping by using a straight edge, and correct by grinding if necessary.

Warping limit:

0.05 mm (0.0020 in)

Grinding limit:

0.1 mm (0.004 in)

Standard height of cylinder block:

201.0 mm (7.91 in)

CYLINDER BLOCK

MECHANICAL

2. CYLINDER AND PISTON

1) The cylinder bore size is stamped on the cylinder block's front upper surface.

CAUTION:

Measurement should be performed at a temperature 20°C (68°F).

NOTE:

Standard sized pistons are classified into two grades, "A" and "B". These grades should be used as a guide line in selecting a standard piston.

Standard diameter:

A: 99.505 — 99.515 mm (3.9175 — 3.9179 in)

B: 99.495 — 99.505 mm (3.9171 — 3.9175 in)

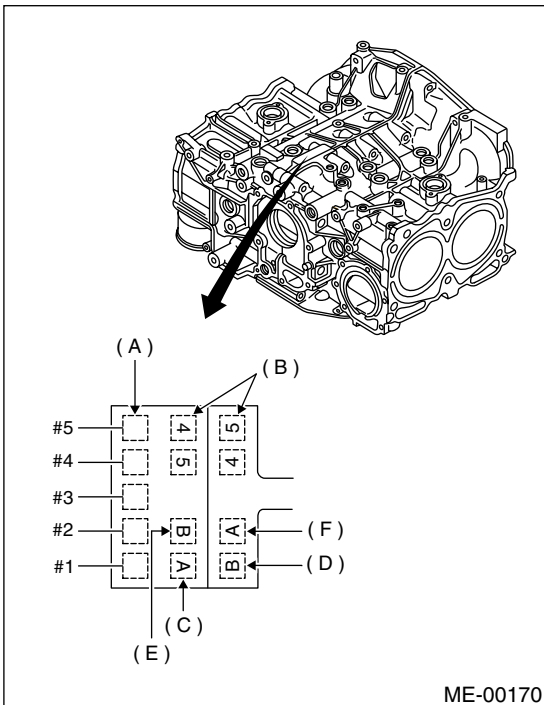

- (A) Main journal size mark
- (B) Cylinder block RH-LH combination mark
- (C) #1 cylinder bore size mark
- (D) #2 cylinder bore size mark
- (E) #3 cylinder bore size mark
- (F) #4 cylinder bore size mark

2) How to measure the inner diameter of each cylinder

Measure the inner diameter of each cylinder in both the thrust and piston pin directions at the heights shown in the figure, using a cylinder bore gauge.

NOTE:

Measurement should be performed at a temperature 20°C (68°F).

Taper:

Standard

0.015 mm (0.0006 in)

Limit

0.050 mm (0.0020 in)

Out-of-roundness:

Standard

0.010 mm (0.0004 in)

Limit

0.050 mm (0.0020 in)

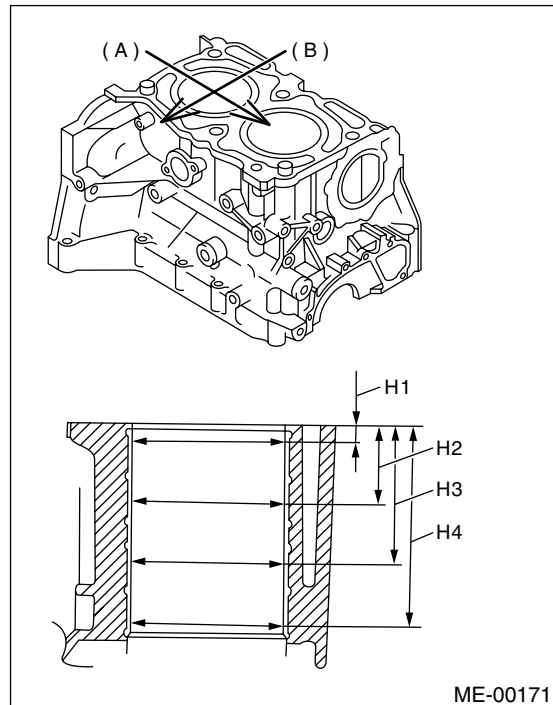

- (A) Piston pin direction
- (B) Thrust direction
- H1 10 mm (0.39 in)
- H2 45 mm (1.77 in)
- H3 80 mm (3.15 in)
- H4 115 mm (4.53 in)

3) When piston is to be replaced due to general or cylinder wear, determine a suitable sized piston by measuring the piston clearance.

4) How to measure the outer diameter of each piston

Measure the outer diameter of each piston at the height shown in the figure. (Thrust direction)

NOTE:

Measurement should be performed at a temperature of 20°C (68°F).

Piston grade point H:

37.0 mm (1.457 in)

Piston outer diameter:

Except U5

Standard

**A: 99.485 — 99.495 mm
(3.9167 — 3.9171 in)**

**B: 99.475 — 99.485 mm
(3.9163 — 3.9167 in)**

0.25 mm (0.0098 in) oversize

**99.725 — 99.735 mm
(3.9262 — 3.9266 in)**

0.50 mm (0.0197 in) oversize

**99.975 — 99.985 mm
(3.9360 — 3.9364 in)**

U5

Standard

(3.9175 — 3.9179 in)

**B: 99.495 — 99.505 mm
(3.9171 — 3.9175 in)**

0.25 mm (0.0098 in) oversize

**99.745 — 99.765 mm
(3.9270 — 3.9278 in)**

0.50 mm (0.0197 in) oversize

**99.995 — 100.015 mm
(3.9368 — 3.9376 in)**

5) Calculate the clearance between cylinder and piston.

NOTE:

Measurement should be performed at a temperature of 20°C (68°F).

Cylinder to piston clearance at 20°C (68°F):

Except U5

Standard

0.010 — 0.030 mm (0.0004 — 0.0012 in)

U5

Standard

-0.010 — 0.010 mm (0.0004 — 0.0004 in)

6) Boring and honing

(1) If the value of taper, out-of-roundness, or cylinder-to-piston clearance measured exceeds the specified limit or if there is any damage on the cylinder wall, rebore it to use an oversize piston.

NOTE:

When any of the cylinders needs reboring, all other cylinders must be bored at the same time, and use oversize pistons. Do not perform boring on one cylinder only, nor use an oversize piston for one cylinder only.

(2) If the cylinder inner diameter exceeds the limit after boring and honing, replace the crankcase.

NOTE:

Immediately after reboring, the cylinder diameter may differ from its real diameter due to temperature rise. Thus, pay attention to this when measuring the cylinder diameter.

Limit of cylinder enlarging (boring):

0.5 mm (0.020 in)

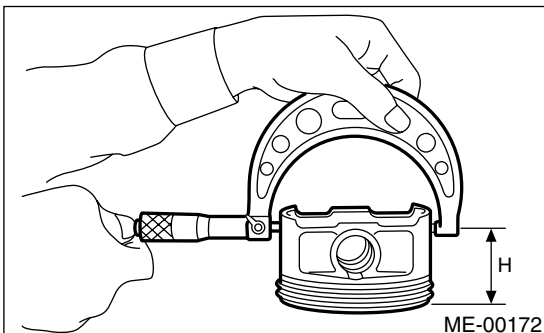

CYLINDER BLOCK

MECHANICAL

3. PISTON AND PISTON PIN

1) Check pistons and piston pins for damage, cracks, and wear and the piston ring grooves for wear and damage. Replace if defective.

2) Measure the piston-to-cylinder clearance at each cylinder. <Ref. to ME(H4SO)-84, CYLINDER AND PISTON, INSPECTION, Cylinder Block.> If any of the clearances is not to specification, replace the piston or bore the cylinder to use an over-size piston.

3) Make sure that piston pin can be inserted into the piston pin hole with a thumb at 20°C (68°F). Replace if defective.

Standard clearance between piston pin and hole in piston:

Standard

0.004 — 0.008 mm (0.0002 — 0.0003 in)

Limit

0.020 mm (0.0008 in)

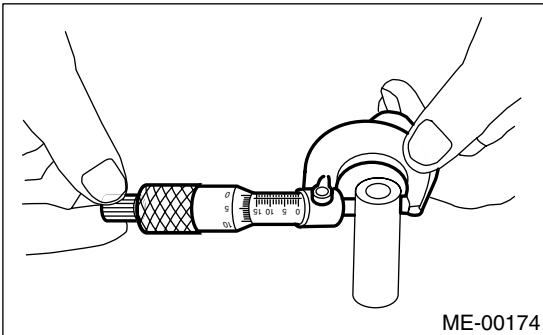
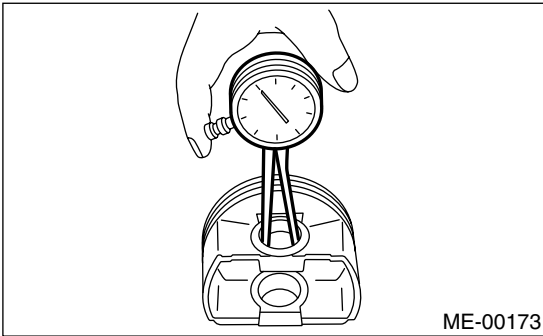

4) Check snap ring installation groove on the piston for burr. If necessary, remove burr (A) from the groove so that piston pin can lightly move.

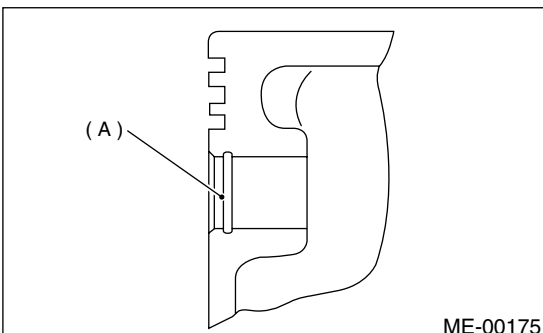

5) Check piston pin snap ring for distortion, cracks and wear.

4. PISTON RING

1) If piston ring is broken, damaged, or worn, or if its tension is insufficient, or when the piston is replaced, replace piston ring with a new one of the same size as the piston.

NOTE:

- Marks are shown on the end of the top and second rings. When installing the rings to the piston, face this mark upward.
- Oil ring consists of upper rail, expander and lower rail. When installing on piston, be careful of each rail's direction.

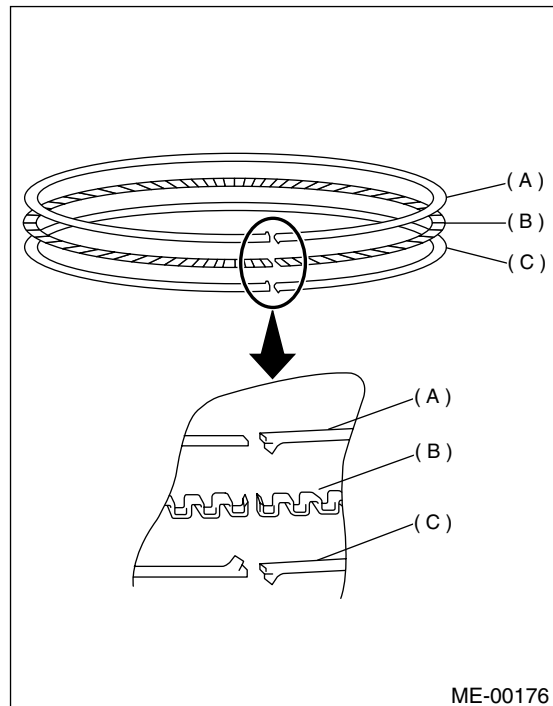

- (A) Upper rail
- (B) Expander
- (C) Lower rail

2) Clean piston ring groove and piston ring.

3) Squarely place piston ring and oil ring in cylinder, and measure the piston ring gap with a thickness gauge.

		Unit: mm (in)	
		Standard	Limit
Piston ring gap	Top ring	0.20 — 0.35 (0.0079 — 0.0138)	1.0 (0.039)
	Second ring	0.37 — 0.52 (0.0146 — 0.0205)	1.0 (0.039)
	Oil ring rail	0.20 — 0.50 (0.0079 — 0.0197)	1.5 (0.059)

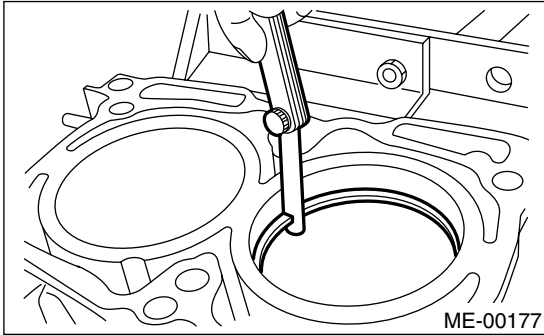

4) Measure the clearance between piston ring and piston ring groove with a thickness gauge.

		Unit: mm (in)	
		Standard	Limit
Clearance between piston ring and piston ring groove	Top ring	0.040 — 0.080 (0.0016 — 0.0031)	0.15 (0.0059)
	Second ring	0.030 — 0.070 (0.0012 — 0.0028)	0.15 (0.0059)

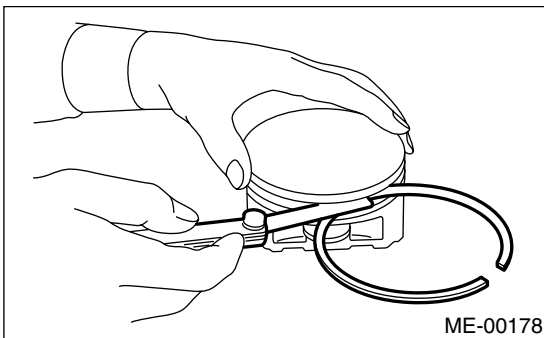

5. CONNECTING ROD

- 1) Replace connecting rod, if the large or small end thrust surface is damaged.
- 2) Check for bend or twist using a connecting rod aligner. Replace connecting rod if the bend or twist exceeds the limit.

Limit of bend or twist per 100 mm (3.94 in) in length:
0.10 mm (0.0039 in)

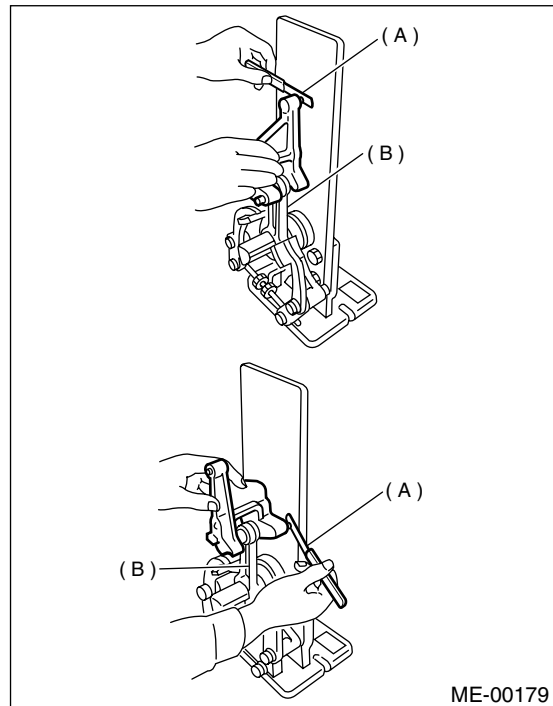

- (A) Thickness gauge
 (B) Connecting rod

3) Install connecting rod fitted with bearing to crankshaft and measure the side clearance (thrust clearance). Replace connecting rod if the side clearance exceeds the specified limit.

Connecting rod side clearance:

Standard

0.070 — 0.330 mm (0.0028 — 0.0130 in)

Limit

0.4 mm (0.016 in)

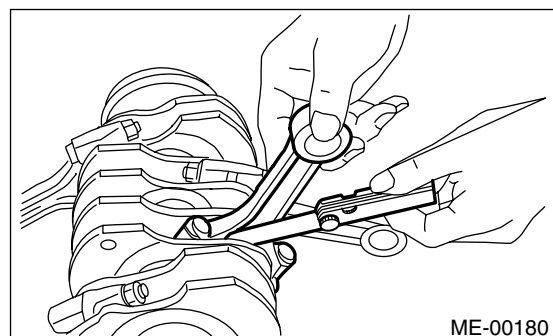

CYLINDER BLOCK

MECHANICAL

4) Inspect connecting rod bearing for scar, peeling, seizure, melting, wear, etc.

5) Measure the oil clearance on individual connecting rod bearings by means of plastigauge. If any oil clearance is not within specification, replace the defective bearing with a new one of standard size or undersize as necessary. (See the table below.)

Connecting rod oil clearance:

Standard

0.016 — 0.044 mm (0.0006 — 0.0017 in)

Limit

0.050 mm (0.0020 in)

Unit: mm (in)		
Bearing	Bearing size (Thickness at center)	Outer diameter of crank pin
Standard	1.490 — 1.502 (0.0587 — 0.0591)	51.984 — 52.000 (2.0466 — 2.0472)
0.03 (0.0012) undersize	1.504 — 1.513 (0.0592 — 0.0596)	51.954 — 51.970 (2.0454 — 2.0461)
0.05 (0.0020) undersize	1.514 — 1.523 (0.0596 — 0.0600)	51.934 — 51.950 (2.0446 — 2.0453)
0.25 (0.0098) undersize	1.614 — 1.622 (0.0635 — 0.0639)	51.734 — 51.750 (2.0368 — 2.0374)

6) Inspect bushing at connecting rod small end, and replace if worn or damaged. Also measure the piston pin clearance at the connecting rod small end.

Clearance between piston pin and bushing:

Standard

0 — 0.022 mm (0 — 0.0009 in)

Limit

0.030 mm (0.0012 in)

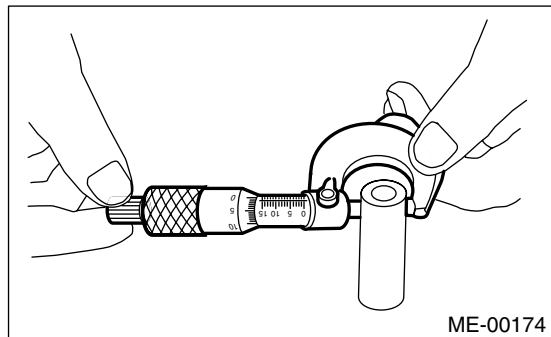
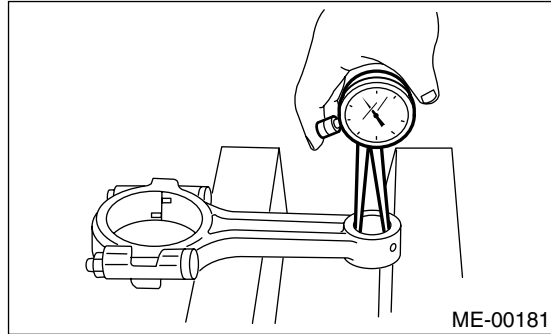

7) Replacement procedure is as follows.

(1) Remove bushing from connecting rod with ST and press.

(2) Press bushing with ST and press after applying oil on the periphery of bushing.

ST 499037100 CONNECTING ROD BUSHING REMOVER AND INSTALLER

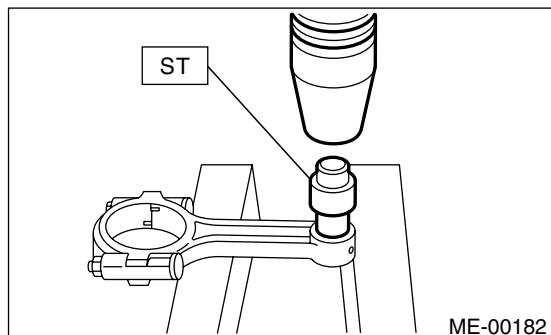

(3) Make two 3 mm (0.12 in) holes in bushing. Ream the inside of bushing.

(4) After completion of reaming, clean bushing to remove chips.

6. CRANKSHAFT AND CRANKSHAFT BEARING

- 1) Clean crankshaft completely and check for cracks by means of red lead check etc., and replace if defective.
- 2) Measure the crankshaft bend, and correct or replace if it exceeds the limit.

CAUTION:

If a suitable V-block is not available, install #1 and #5 crankshaft bearing on cylinder block, position crankshaft on these bearings and measure crankshaft bend using a dial gauge.

Crankshaft bend limit:
0.035 mm (0.0014 in)

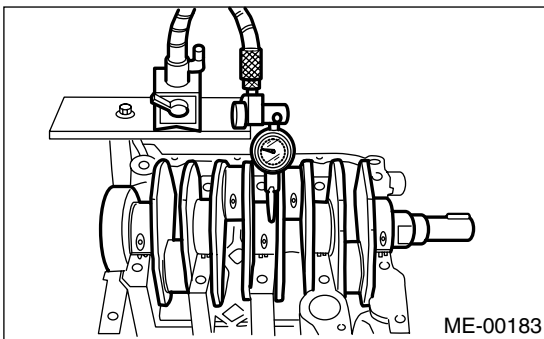

- 3) Inspect the crank journal and crank pin for wear. If they are not within the specifications, replace bearing with a suitable (undersize) one, and replace or recondition crankshaft as necessary. When grinding crank journal or crank pin, finish them to the specified dimensions according to the undersize bearing to be used.

Crank pin and crank journal:

Out-of-roundness

0.020 mm (0.0008 in) or less

Taper limit

0.07 mm (0.0028 in)

Grinding limit

0.250 mm (0.0098 in)

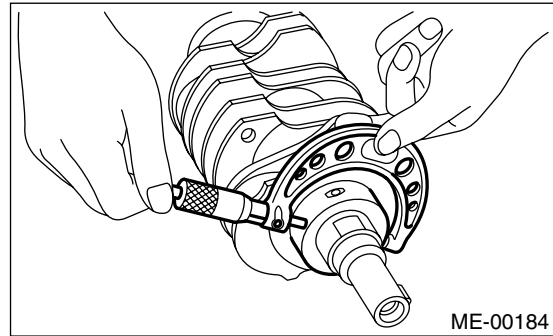

		Unit: mm (in)		
		Crank journal diameter		Crank pin diameter
		#1, #3	#2, #4, #5	
Standard	Journal O.D.	59.992 — 60.008 (2.3619 — 2.3625)	59.992 — 60.008 (2.3619 — 2.3625)	51.984 — 52.000 (2.0466 — 2.0472)
	Bearing size (Thickness at center)	1.998 — 2.011 (0.0787 — 0.0792)	2.000 — 2.013 (0.0787 — 0.0793)	1.490 — 1.502 (0.0587 — 0.0591)
0.03 (0.0012) undersize	Journal O.D.	59.962 — 59.978 (2.3607 — 2.3613)	59.962 — 59.978 (2.3607 — 2.3613)	51.954 — 51.970 (2.0454 — 2.0461)
	Bearing size (Thickness at center)	2.017 — 2.020 (0.0794 — 0.0795)	2.019 — 2.022 (0.0795 — 0.0796)	1.504 — 1.513 (0.0592 — 0.0596)
0.05 (0.0020) undersize	Journal O.D.	59.942 — 59.958 (2.3599 — 2.3605)	59.942 — 59.958 (2.3599 — 2.3605)	51.934 — 51.950 (2.0446 — 2.0453)
	Bearing size (Thickness at center)	2.027 — 2.030 (0.0798 — 0.0799)	2.029 — 2.032 (0.0799 — 0.0800)	1.514 — 1.523 (0.0596 — 0.0600)
0.25 (0.0098) undersize	Journal O.D.	59.742 — 59.758 (2.3520 — 2.3527)	59.742 — 59.758 (2.3520 — 2.3527)	51.734 — 51.750 (2.0368 — 2.0374)
	Bearing size (Thickness at center)	2.127 — 2.130 (0.0837 — 0.0839)	2.129 — 2.132 (0.0838 — 0.0839)	1.614 — 1.623 (0.0635 — 0.0639)

O.D. ... Outer Diameter

CYLINDER BLOCK

MECHANICAL

4) Measure the thrust clearance of crankshaft at center bearing. If the clearance exceeds the limit, replace bearing.

Crankshaft thrust clearance:

Standard

0.030 — 0.115 mm (0.0012 — 0.0045 in)

Limit

0.25 mm (0.0098 in)

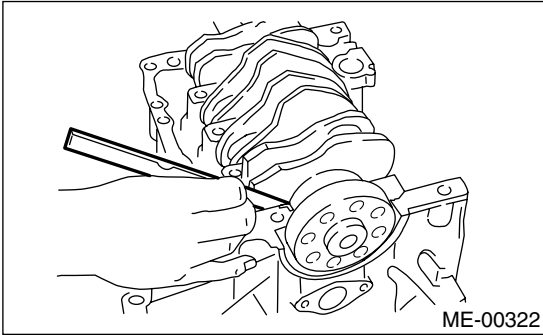

5) Inspect individual crankshaft bearings for signs of flaking, seizure, melting, and wear.

6) Measure the oil clearance on each crankshaft bearing by means of plastigauge. If the measurement is not within the specification, replace defective bearing with an undersize one, and replace or recondition crankshaft as necessary.

Crankshaft	Oil clearance	#1	Standard	0.010 — 0.030 mm (0.0004 — 0.0012 in)
			Limit	0.040 mm (0.0016 in)
		#2	Standard	0.010 — 0.030 mm (0.0004 — 0.0012 in)
			Limit	0.045 (0.0018 in)
		#3	Standard	0.010 — 0.030 mm (0.0004 — 0.0012 in)
			Limit	0.040 mm (0.0016 in)
		#4	Standard	0.010 — 0.030 mm (0.0004 — 0.0012 in)
			Limit	0.045 mm (0.0018 in)
		#5	Standard	0.010 — 0.031 mm (0.0004 — 0.0012 in)
			Limit	0.040 mm (0.0016 in)

ENGINE TROUBLE IN GENERAL

MECHANICAL

22.Engine Trouble in General

A: INSPECTION

NOTE:

“RANK” shown in the chart refer to the possibility of reason for the trouble in order (“Very often” to “Rarely”)

A — Very often

B — Sometimes

C — Rarely

TROUBLE	PROBLEM PARTS, ETC.	POSSIBLE CAUSE	RANK
1. Engine will not start.			
1) Starter does not turn.	• Starter	• Defective battery-to-starter harness	B
		• Defective starter switch	C
		• Defective inhibitor switch or neutral switch	C
		• Defective starter	B
	• Battery	• Poor terminal connection	A
		• Run-down battery	A
		• Defective charging system	B
	• Friction	• Seizure of crankshaft and connecting rod bearing	C
		• Seized camshaft	C
• Seized or stuck piston and cylinder		C	
2) Initial combustion does not occur.	• Starter	• Defective starter	C
	• Engine control system <Ref. to EN(H4SO)-2, Basic Diagnostic Procedure.>		A
	• Fuel line	• Defective fuel pump and relay	A
		• Lack of or insufficient fuel	B
	• Belt	• Defective	B
		• Defective timing	B
	• Compression	• Incorrect valve clearance	C
		• Loosened spark plugs or defective gasket	C
		• Loosened cylinder head bolts or defective gasket	C
		• Improper valve seating	C
		• Defective valve stem	C
		• Worn or broken valve spring	B
		• Worn or stuck piston rings, cylinder and piston	C
		• Incorrect valve timing	B
	• Improper engine oil (low viscosity)	B	
3) Initial combustion occur.	• Engine control system <Ref. to EN(H4SO)-2, Basic Diagnostic Procedure.>		A
	• Intake system	• Defective intake manifold gasket	B
		• Defective throttle body gasket	B
	• Fuel line	• Defective fuel pump and relay	C
		• Clogged fuel line	C
		• Lack of or insufficient fuel	B
	• Belt	• Defective	B
		• Defective timing	B
	• Compression	• Incorrect valve clearance	C
		• Loosened spark plugs or defective gasket	C
		• Loosened cylinder head bolts or defective gasket	C
		• Improper valve seating	C
		• Defective valve stem	C
		• Worn or broken valve spring	B
		• Worn or stuck piston rings, cylinder and piston	C
• Incorrect valve timing		B	
• Improper engine oil (low viscosity)	B		

ENGINE TROUBLE IN GENERAL

MECHANICAL

TROUBLE	PROBLEM PARTS, ETC.	POSSIBLE CAUSE	RANK
4) Engine stalls after initial combustion.	• Engine control system <Ref. to EN(H4SO)-2, Basic Diagnostic Procedure.>		A
	• Intake system	• Loosened or cracked intake duct	B
		• Loosened or cracked PCV hose	C
		• Loosened or cracked vacuum hose	C
		• Defective intake manifold gasket	B
		• Defective throttle body gasket	B
		• Dirty air cleaner element	C
	• Fuel line	• Clogged fuel line	C
		• Lack of or insufficient fuel	B
	• Belt	• Defective	B
		• Defective timing	B
	• Compression	• Incorrect valve clearance	C
		• Loosened spark plugs or defective gasket	C
		• Loosened cylinder head bolts or defective gasket	C
		• Improper valve seating	C
		• Defective valve stem	C
		• Worn or broken valve spring	B
• Worn or stuck piston rings, cylinder and piston		C	
• Incorrect valve timing		B	
• Improper engine oil (low viscosity)		B	
2. Rough idle and engine stall	• Engine control system <Ref. to EN(H4SO)-2, Basic Diagnostic Procedure.>		A
	• Intake system	• Loosened or cracked intake duct	A
		• Loosened or cracked PCV hose	A
		• Loosened or cracked vacuum hose	A
		• Defective intake manifold gasket	B
		• Defective throttle body gasket	B
		• Defective PCV valve	C
		• Loosened oil filler cap	B
		• Dirty air cleaner element	C
	• Fuel line	• Defective fuel pump and relay	C
		• Clogged fuel line	C
		• Lack of or insufficient fuel	B
	• Belt	• Defective timing	C
	• Compression	• Incorrect valve clearance	B
		• Loosened spark plugs or defective gasket	B
		• Loosened cylinder head bolts or defective gasket	B
		• Improper valve seating	B
		• Defective valve stem	C
		• Worn or broken valve spring	B
		• Worn or stuck piston rings, cylinder and piston	B
		• Incorrect valve timing	A
		• Improper engine oil (low viscosity)	B
	• Lubrication system	• Incorrect oil pressure	B
		• Defective rocker cover gasket	C
	• Cooling system	• Overheating	C
	• Others	• Malfunction of evaporative emission control system	A
		• Stuck or damaged throttle valve	B
		• Accelerator cable out of adjustment	C

ENGINE TROUBLE IN GENERAL

MECHANICAL

TROUBLE	PROBLEM PARTS, ETC.	POSSIBLE CAUSE	RANK
3. Low output, hesitation and poor acceleration	• Engine control system <Ref. to EN(H4SO)-2, Basic Diagnostic Procedure.>		A
	• Intake system	• Loosened or cracked intake duct	A
		• Loosened or cracked PCV hose	A
		• Loosened or cracked vacuum hose	B
		• Defective intake manifold gasket	B
		• Defective throttle body gasket	B
		• Defective PCV valve	B
		• Loosened oil filler cap	B
		• Dirty air cleaner element	A
	• Fuel line	• Defective fuel pump and relay	B
		• Clogged fuel line	B
		• Lack of or insufficient fuel	C
	• Belt	• Defective timing	B
	• Compression	• Incorrect valve clearance	B
		• Loosened spark plugs or defective gasket	B
		• Loosened cylinder head bolts or defective gasket	B
		• Improper valve seating	B
		• Defective valve stem	C
		• Worn or broken valve spring	B
		• Worn or stuck piston rings, cylinder and piston	C
• Incorrect valve timing		A	
• Improper engine oil (low viscosity)	B		
• Lubrication system	• Incorrect oil pressure	B	
• Cooling system	• Overheating	C	
	• Over cooling	C	
• Others	• Malfunction of evaporative emission control system	A	
4. Surging	• Engine control system <Ref. to EN(H4SO)-2, Basic Diagnostic Procedure.>		A
	• Intake system	• Loosened or cracked intake duct	A
		• Loosened or cracked PCV hose	A
		• Loosened or cracked vacuum hose	A
		• Defective intake manifold gasket	B
		• Defective throttle body gasket	B
		• Defective PCV valve	B
		• Loosened oil filler cap	B
		• Dirty air cleaner element	B
	• Fuel line	• Defective fuel pump and relay	B
		• Clogged fuel line	B
		• Lack of or insufficient fuel	C
	• Belt	• Defective timing	B
	• Compression	• Incorrect valve clearance	B
		• Loosened spark plugs or defective gasket	C
		• Loosened cylinder head bolts or defective gasket	C
		• Improper valve seating	C
		• Defective valve stem	C
		• Worn or broken valve spring	C
		• Worn or stuck piston rings, cylinder and piston	C
• Incorrect valve timing		A	
• Improper engine oil (low viscosity)	B		
• Cooling system	• Overheating	B	
• Others	• Malfunction of evaporative emission control system	C	

ENGINE TROUBLE IN GENERAL

MECHANICAL

TROUBLE	PROBLEM PARTS, ETC.	POSSIBLE CAUSE	RANK
5. Engine does not return to idle.	• Engine control system <Ref. to EN(H4SO)-2, Basic Diagnostic Procedure.>		A
	• Intake system	• Loosened or cracked vacuum hose	A
	• Others	• Stuck or damaged throttle valve	A
		• Accelerator cable out of adjustment	B
6. Dieseling (Run-on)	• Engine control system <Ref. to EN(H4SO)-2, Basic Diagnostic Procedure.>		A
	• Cooling system	• Overheating	B
	• Others	• Malfunction of evaporative emission control system	B
7. After burning in exhaust system	• Engine control system <Ref. to EN(H4SO)-2, Basic Diagnostic Procedure.>		A
	• Intake system	• Loosened or cracked intake duct	C
		• Loosened or cracked PCV hose	C
		• Loosened or cracked vacuum hose	B
		• Defective PCV valve	B
		• Loosened oil filler cap	C
	• Belt	• Defective timing	B
	• Compression	• Incorrect valve clearance	B
		• Loosened spark plugs or defective gasket	C
		• Loosened cylinder head bolts or defective gasket	C
		• Improper valve seating	B
		• Defective valve stem	C
		• Worn or broken valve spring	C
		• Worn or stuck piston rings, cylinder and piston	C
	• Incorrect valve timing	A	
• Lubrication system	• Incorrect oil pressure	C	
• Cooling system	• Over cooling	C	
• Others	• Malfunction of evaporative emission control system	C	
8. Knocking	• Engine control system <Ref. to EN(H4SO)-2, Basic Diagnostic Procedure.>		A
	• Intake system	• Loosened oil filler cap	B
	• Belt	• Defective timing	B
	• Compression	• Incorrect valve clearance	C
		• Incorrect valve timing	B
	• Cooling system	• Overheating	A
9. Excessive engine oil consumption	• Intake system	• Loosened or cracked PCV hose	A
		• Defective PCV valve	B
		• Loosened oil filler cap	C
	• Compression	• Defective valve stem	A
		• Worn or stuck piston rings, cylinder and piston	A
	• Lubrication system	• Loosened oil pump attaching bolts and defective gasket	B
		• Defective oil filler seal	B
		• Defective crankshaft oil seal	B
		• Defective rocker cover gasket	B
		• Loosened oil drain plug or defective gasket	B
	• Loosened oil pan fitting bolts or defective oil pan	B	

ENGINE TROUBLE IN GENERAL

MECHANICAL

TROUBLE	PROBLEM PARTS, ETC.	POSSIBLE CAUSE	RANK	
10. Excessive fuel consumption	• Engine control system <Ref. to EN(H4SO)-2, Basic Diagnostic Procedure.>		A	
	• Intake system	• Dirty air cleaner element	A	
	• Belt	• Defective timing	B	
	• Compression	• Incorrect valve clearance		B
		• Loosened spark plugs or defective gasket		C
		• Loosened cylinder head bolts or defective gasket		C
		• Improper valve seating		B
		• Defective valve stem		C
		• Worn or broken valve spring		C
		• Worn or stuck piston rings, cylinder and piston		B
		• Incorrect valve timing		B
	• Lubrication system	• Incorrect oil pressure		C
	• Cooling system	• Over cooling		C
• Others	• Accelerator cable out of adjustment		B	

ENGINE NOISE

MECHANICAL

23.Engine Noise

A: INSPECTION

Type of sound	Condition	Possible cause
Regular clicking sound	Sound increases as engine speed increases.	<ul style="list-style-type: none"> Valve mechanism is defective. Incorrect valve clearance Worn valve rocker Worn camshaft Broken valve spring
Heavy and dull clank	Oil pressure is low.	<ul style="list-style-type: none"> Worn crankshaft main bearing Worn connecting rod bearing (big end)
	Oil pressure is normal.	<ul style="list-style-type: none"> Loose flywheel mounting bolts Damaged engine mounting
High-pitched clank (Spark knock)	Sound is noticeable when accelerating with an overload.	<ul style="list-style-type: none"> Ignition timing advanced Accumulation of carbon inside combustion chamber Wrong spark plug Improper gasoline
Clank when engine speed is medium (1,000 to 2,000 rpm).	Sound is reduced when fuel injector connector of noisy cylinder is disconnected. (NOTE*)	<ul style="list-style-type: none"> Worn crankshaft main bearing Worn bearing at crankshaft end of connecting rod
Knocking sound when engine is operating under idling speed and engine is warm	Sound is reduced when fuel injector connector of noisy cylinder is disconnected. (NOTE*)	<ul style="list-style-type: none"> Worn cylinder liner and piston ring Broken or stuck piston ring Worn piston pin and hole at piston end of connecting rod
	Sound is not reduced if each fuel injector connector is disconnected in turn. (NOTE*)	<ul style="list-style-type: none"> Unusually worn valve lifter Worn cam gear Worn camshaft journal bore in crankcase
Squeaky sound	—	<ul style="list-style-type: none"> Insufficient generator lubrication
Rubbing sound	—	<ul style="list-style-type: none"> Defective generator brush and rotor contact
Gear scream when starting engine	—	<ul style="list-style-type: none"> Defective ignition starter switch Worn gear and starter pinion
Sound like polishing glass with a dry cloth	—	<ul style="list-style-type: none"> Loose drive belt Defective water pump shaft
Hissing sound	—	<ul style="list-style-type: none"> Loss of compression Air leakage in air intake system, hoses, connections or manifolds
Timing belt noise	—	<ul style="list-style-type: none"> Loose timing belt Belt contacting case/adjacent part
Valve tappet noise	—	<ul style="list-style-type: none"> Incorrect valve clearance

NOTE*:

When disconnecting fuel injector connector, Malfunction Indicator Light (CHECK ENGINE light) illuminates and trouble code is stored in ECM memory.

Therefore, carry out the CLEAR MEMORY MODE <Ref. to EN(H4SO)-50, Clear Memory Mode.> and INSPECTION MODE <Ref. to EN(H4SO)-42, Inspection Mode.> after connecting fuel injector connector.