

EXHAUST

EX(H4SO)

	Page
1. General Description	2
2. Front Exhaust Pipe.....	5
3. Center Exhaust Pipe	8
4. Rear Exhaust Pipe	9
5. Muffler	10

GENERAL DESCRIPTION

EXHAUST

1. General Description

A: COMPONENT

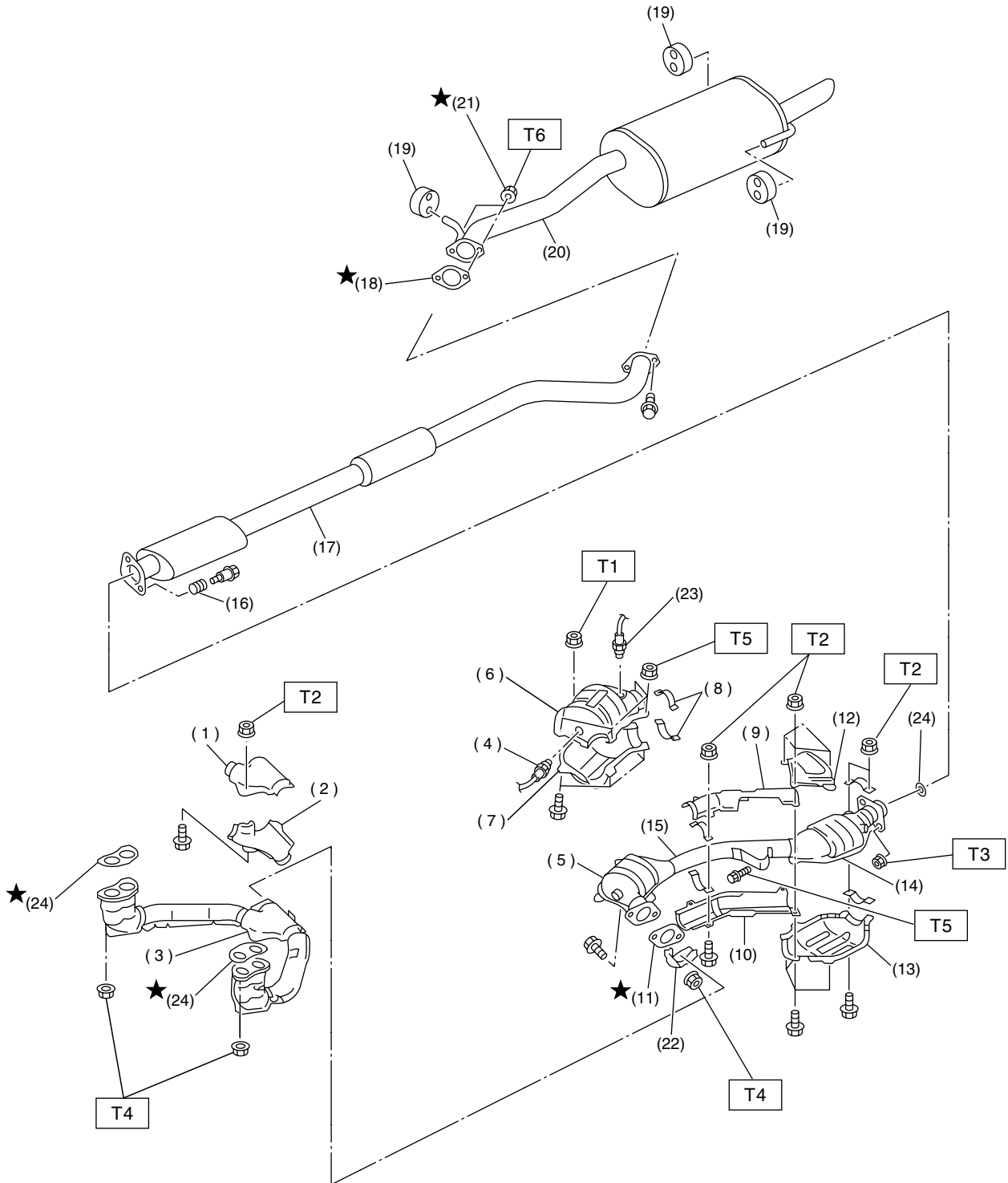

EX-00251

GENERAL DESCRIPTION

EXHAUST

(1) Upper front exhaust pipe cover CTR	(11) Gasket	(23) Rear oxygen sensor
(2) Lower front exhaust pipe cover CTR	(12) Upper rear catalytic converter cover	(24) Gasket
(3) Front exhaust pipe	(13) Lower rear catalytic converter cover (Except PICKUP)	
(4) Front oxygen (A/F) sensor	(14) Rear catalytic converter	
(5) Front catalytic converter	(15) Center exhaust pipe	
(6) Upper front catalytic converter cover	(16) Spring	
(7) Lower front catalytic converter cover	(17) Rear exhaust pipe	
(8) Clamp	(18) Gasket	
(9) Upper center exhaust pipe cover	(19) Cushion rubber	
(10) Lower center exhaust pipe cover	(20) Muffler	
	(21) Self-locking nut	
	(22) Protector	

Tightening torque: N·m (kgf-m, ft-lb)

T1: 8 (0.8, 5.8)

T2: 13 (1.3, 9.4)

T3: 18 (1.8, 13.0)

T4: 30 (3.1, 22.4)

T5: 35 (3.6, 26.0)

T6: 48 (4.9, 35.4)

GENERAL DESCRIPTION

EXHAUST

B: CAUTION

- Wear working clothing, including a cap, protective goggles, and protective shoes during operation.
- Remove contamination including dirt and corrosion before removal, installation or disassembly.
- Keep the disassembled parts in order and protect them from dust or dirt.
- Before removal, installation or disassembly, be sure to clarify the failure. Avoid unnecessary removal, installation, disassembly, and replacement.
- Be careful not to burn your hands, because each part on the vehicle is hot after running.
- Be sure to tighten fasteners including bolts and nuts to the specified torque.
- Place shop jacks or safety stands at the specified points.
- Before disconnecting electrical connectors of sensors or units, be sure to disconnect ground cable from battery.

2. Front Exhaust Pipe

A: REMOVAL

1) Disconnect battery ground cable.

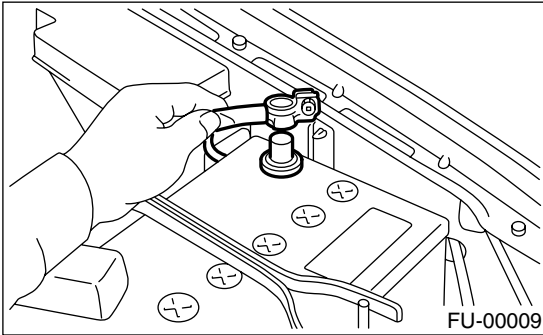

2) Disconnect front oxygen (A/F) sensor connector.

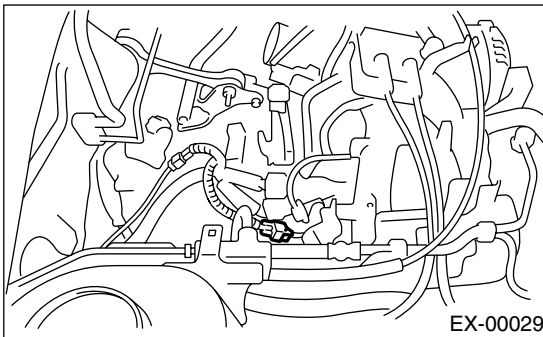

3) Disconnect rear oxygen sensor connector.

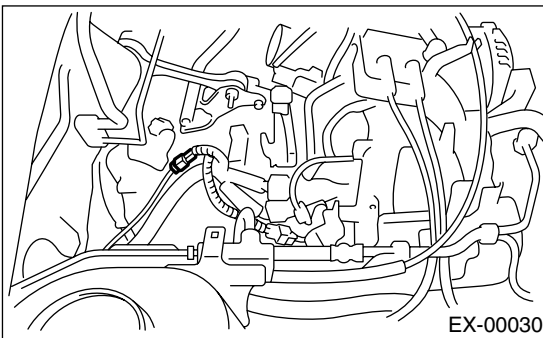

4) Lift-up the vehicle.

5) Separate front and center exhaust pipe assembly from rear exhaust pipe.

WARNING:

Be careful, exhaust pipe is hot.

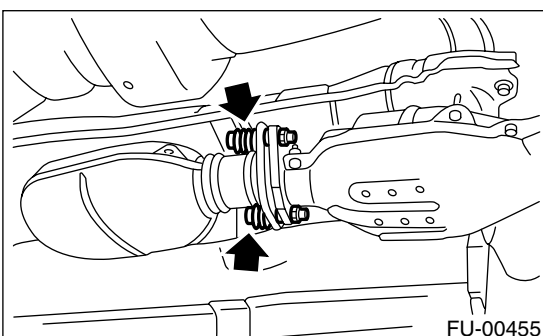

6) Remove under cover.

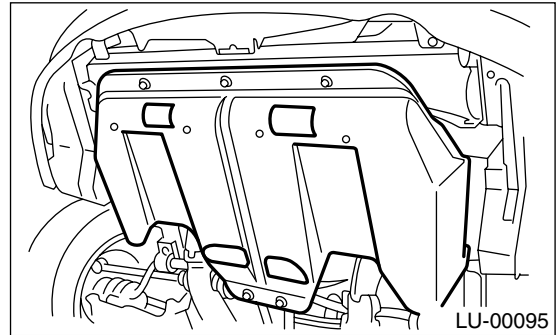

7) Remove nuts which hold front exhaust pipe onto cylinder heads.

CAUTION:

Be careful not to pull down front and center exhaust pipe assembly.

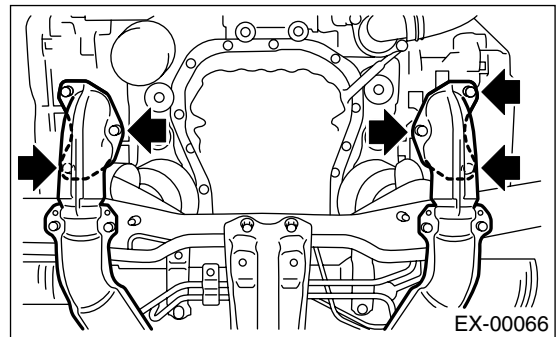

8) Remove bolt which installs front and center exhaust pipe assembly to hanger bracket.

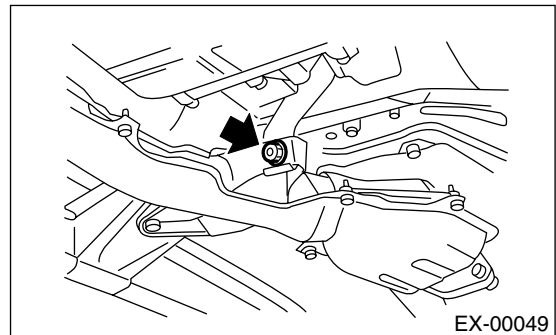

9) Remove front and center exhaust pipe assembly from the vehicle.

CAUTION:

- Be careful not to let front and center exhaust pipe assembly fall off when removing as it is quite heavy.
- After removing front and center exhaust assembly, do not apply excessive pulling force on rear exhaust pipe.

FRONT EXHAUST PIPE

EXHAUST

10) Separate front exhaust pipe from center exhaust pipe.

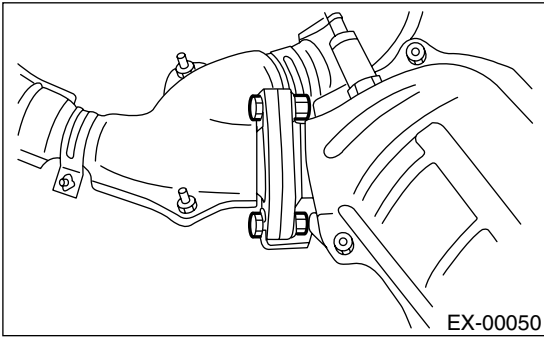

B: INSTALLATION

1) Install front exhaust pipe to center exhaust pipe.

NOTE:

Replace gaskets with new ones.

Tightening torque:

30 N·m (3.1 kgf-m, 22.4 ft-lb)

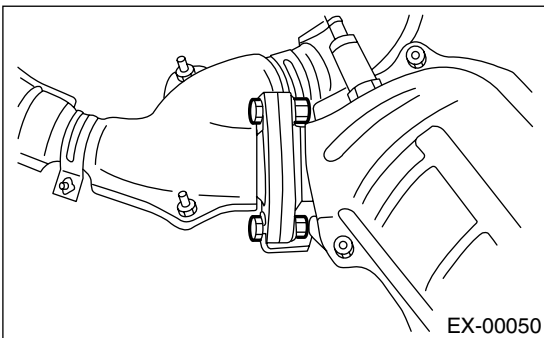

2) Install front and center exhaust pipe assembly to the vehicle.

3) Temporarily tighten bolt which installs front and center exhaust pipe assembly to hanger bracket.

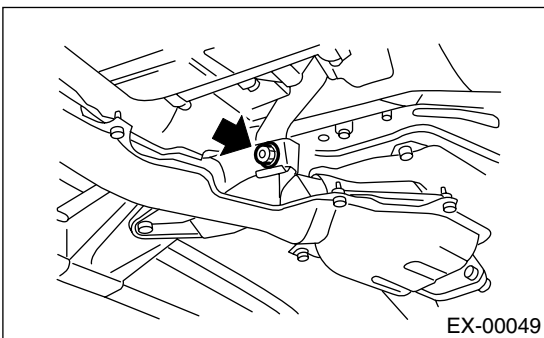

4) Tighten nuts which hold front exhaust pipe onto cylinder heads.

Tightening torque:

30 N·m (3.1 kgf-m, 22.4 ft-lb)

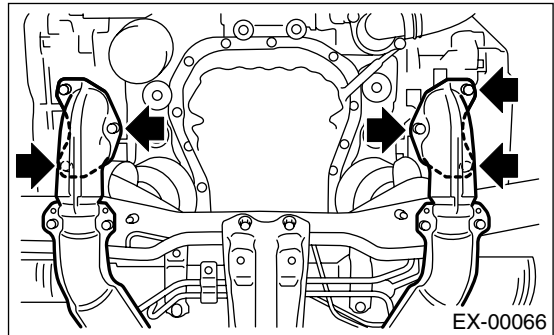

5) Install under cover.

6) Tighten bolts which install front and center exhaust pipe assembly to rear exhaust pipe.

Tightening torque:

18 N·m (1.8 kgf-m, 13.0 ft-lb)

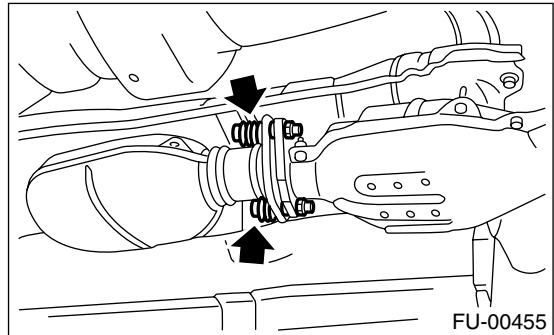

7) Tighten bolt which holds front and center exhaust pipe assembly to hanger bracket.

Tightening torque:

35 N·m (3.6 kgf-m, 26.0 ft-lb)

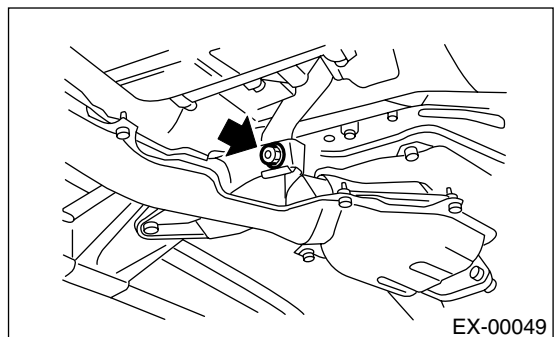

8) Lower the vehicle.

9) Connect rear oxygen sensor connector.

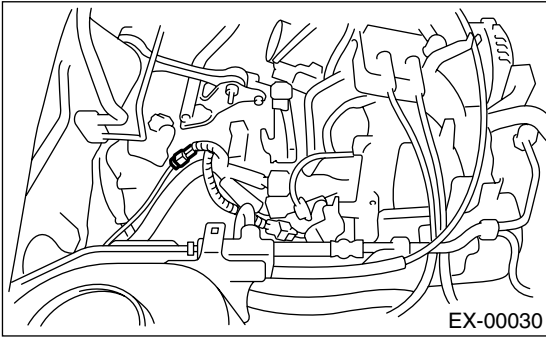

10) Connect front oxygen (A/F) sensor connector.

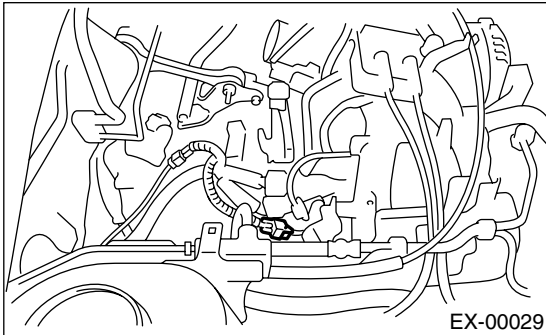

11) Connect battery ground cable.

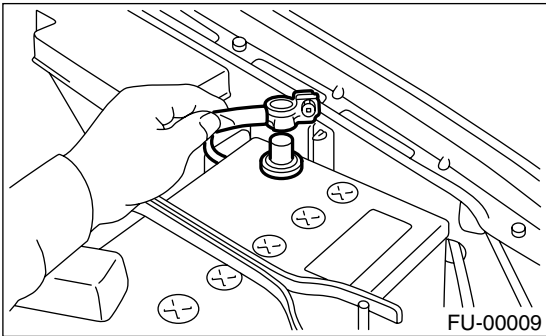

C: INSPECTION

- 1) Make sure there are no exhaust leaks from connections and welds.
- 2) Make sure there are no holes or rusting.

3. Center Exhaust Pipe

A: REMOVAL

After removing the center and front exhaust pipes as one unit, separate them. Refer to the procedure for removing the front exhaust pipe. <Ref. to EX(H4SO)-5, REMOVAL, Front Exhaust Pipe.>

B: INSTALLATION

Install the center exhaust pipe and front exhaust pipe as one unit. Refer to the procedure for installing the front exhaust pipe. <Ref. to EX(H4SO)-6, INSTALLATION, Front Exhaust Pipe.>

C: INSPECTION

- 1) Make sure there are no exhaust leaks from connections and welds.
- 2) Make sure there are no holes or rusting.

4. Rear Exhaust Pipe

A: REMOVAL

1) Separate rear exhaust pipe from center exhaust pipe.

CAUTION:

Be careful, exhaust pipe is hot.

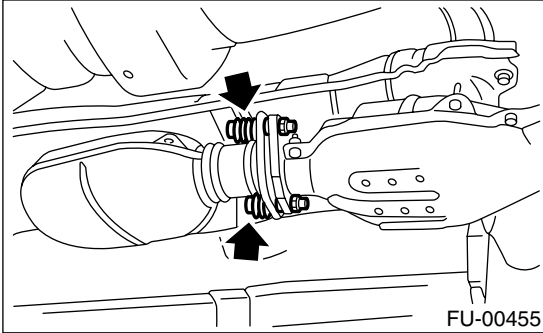

2) Separate rear exhaust pipe from muffler.

CAUTION:

Be careful not to pull down rear exhaust pipe.

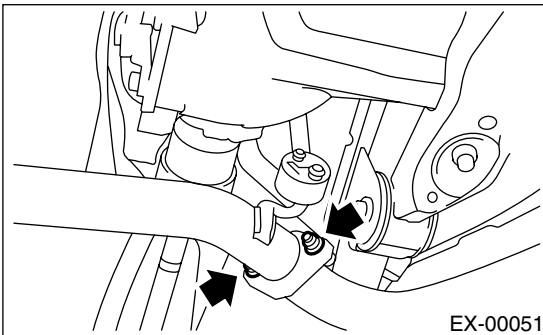

3) Remove rear exhaust pipe.

B: INSTALLATION

NOTE:

Replace gaskets and self-locking nuts with new ones.

1) Install rear exhaust pipe to muffler.

Tightening torque:

48 N·m (4.9 kgf-m, 35.4 ft-lb)

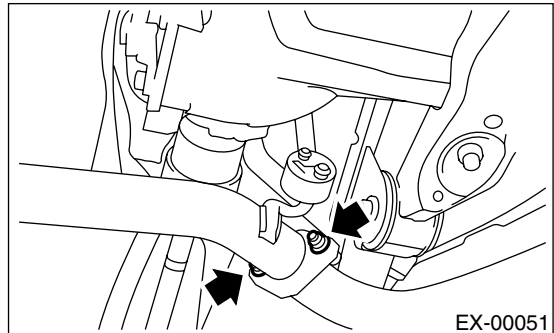

2) Install rear exhaust pipe to center exhaust pipe.

Tightening torque:

18 N·m (1.8 kgf-m, 13.0 ft-lb)

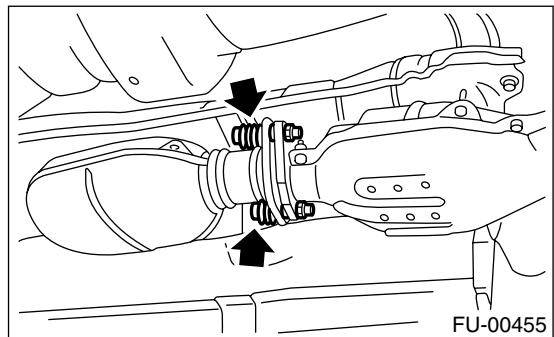

C: INSPECTION

1) Make sure there are no exhaust leaks from connections and welds.

2) Make sure there are no holes or rusting.

3) Make sure the cushion rubber is not worn or cracked.

MUFFLER

EXHAUST

5. Muffler

A: REMOVAL

1) Separate muffler from rear exhaust pipe.

CAUTION:

Be careful, exhaust pipe is hot.

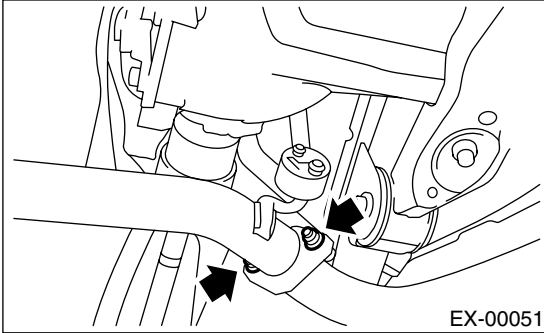

2) Remove left and right cushion rubbers.

CAUTION:

Be careful not to drop the muffler during removal.

NOTE:

To facilitate removal, apply a coat of SUBARU CRC to mating area of cushion rubbers in advance.

SUBARU CRC (Part No. 004301003)

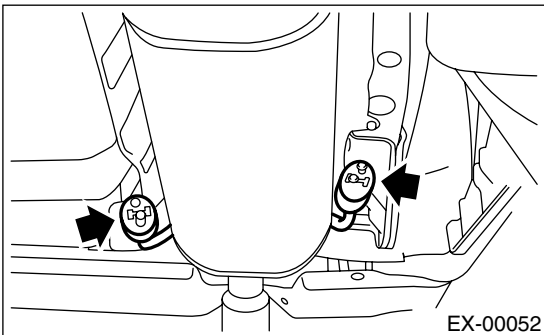

3) Remove front cushion rubber, and detach muffler assembly.

NOTE:

To facilitate removal, apply a coat of SUBARU CRC to mating area of cushion rubber in advance.

SUBARU CRC (Part No. 004301003)

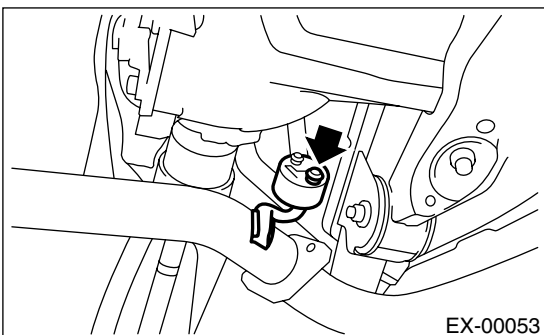

B: INSTALLATION

1) Install in the reverse order of removal.

NOTE:

Replace gasket and self-locking nuts with new ones.

Tightening torque:

48 N·m (4.9 kgf-m, 35.4 ft-lb)

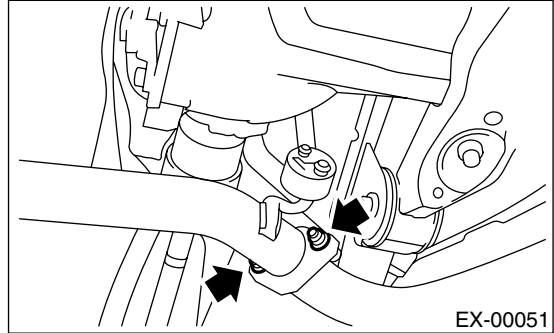

C: INSPECTION

1) Make sure there are no exhaust leaks from connections and welds.

2) Make sure there are no holes or rusting.

3) Make sure the cushion rubber is not worn or cracked.