

# FUEL INJECTION (FUEL SYSTEMS)

# *FU(H4SO U5)*

---

	<b>Page</b>
1. General Description .....	2
2. Throttle Body .....	14
3. Intake Manifold .....	15
4. Engine Coolant Temperature Sensor .....	27
5. Crankshaft Position Sensor .....	28
6. Camshaft Position Sensor .....	29
7. Knock Sensor .....	30
8. Throttle Position Sensor .....	31
9. Pressure Sensor .....	32
10. Air Flow and Intake Air Temperature Sensor .....	33
11. Tumble Generator Valve Assembly .....	34
12. Tumble Generator Valve Actuator .....	35
13. Tumble Generator Valve Position Sensor .....	36
14. EGR Valve .....	37
15. Fuel Injector .....	38
16. Front Oxygen (A/F) Sensor .....	42
17. Front Oxygen Sensor .....	45
18. Rear Oxygen Sensor .....	48
19. Engine Control Module .....	49
20. Main Relay .....	50
21. Fuel Pump Relay .....	51
22. Electronic Control Throttle Relay .....	52
23. Fuel .....	53
24. Fuel Tank .....	55
25. Fuel Filler Pipe .....	63
26. Fuel Pump .....	70
27. Fuel Level Sensor .....	72
28. Fuel Sub Level Sensor .....	73
29. Fuel Filter .....	74
30. Fuel Cut Valve .....	75
31. Fuel Damper Valve .....	76
32. Fuel Delivery, Return and Evaporation Lines .....	77
33. Fuel System Trouble in General .....	80

# GENERAL DESCRIPTION

FUEL INJECTION (FUEL SYSTEMS)

---

## 1. General Description

### A: SPECIFICATIONS

Fuel tank	Capacity	64 ℓ (16.9 US gal, 14.1 Imp gal)
	Location	Under rear seat
Fuel pump	Type	Impeller
	Shutoff discharge pressure	370 — 677 kPa (3.77 — 6.9 kg/cm <sup>2</sup> , 53.6 — 98 psi)
	Discharge flow	More than 65 ℓ (17.2 US gal, 14.3 Imp gal)/h [12 V at 300 kPa (3.06 kg/cm <sup>2</sup> , 43.5 psi)]
Fuel filter		Cartridge type

# GENERAL DESCRIPTION

FUEL INJECTION (FUEL SYSTEMS)

---

**MEMO:**

# GENERAL DESCRIPTION

FUEL INJECTION (FUEL SYSTEMS)

## B: COMPONENT

### 1. INTAKE MANIFOLD

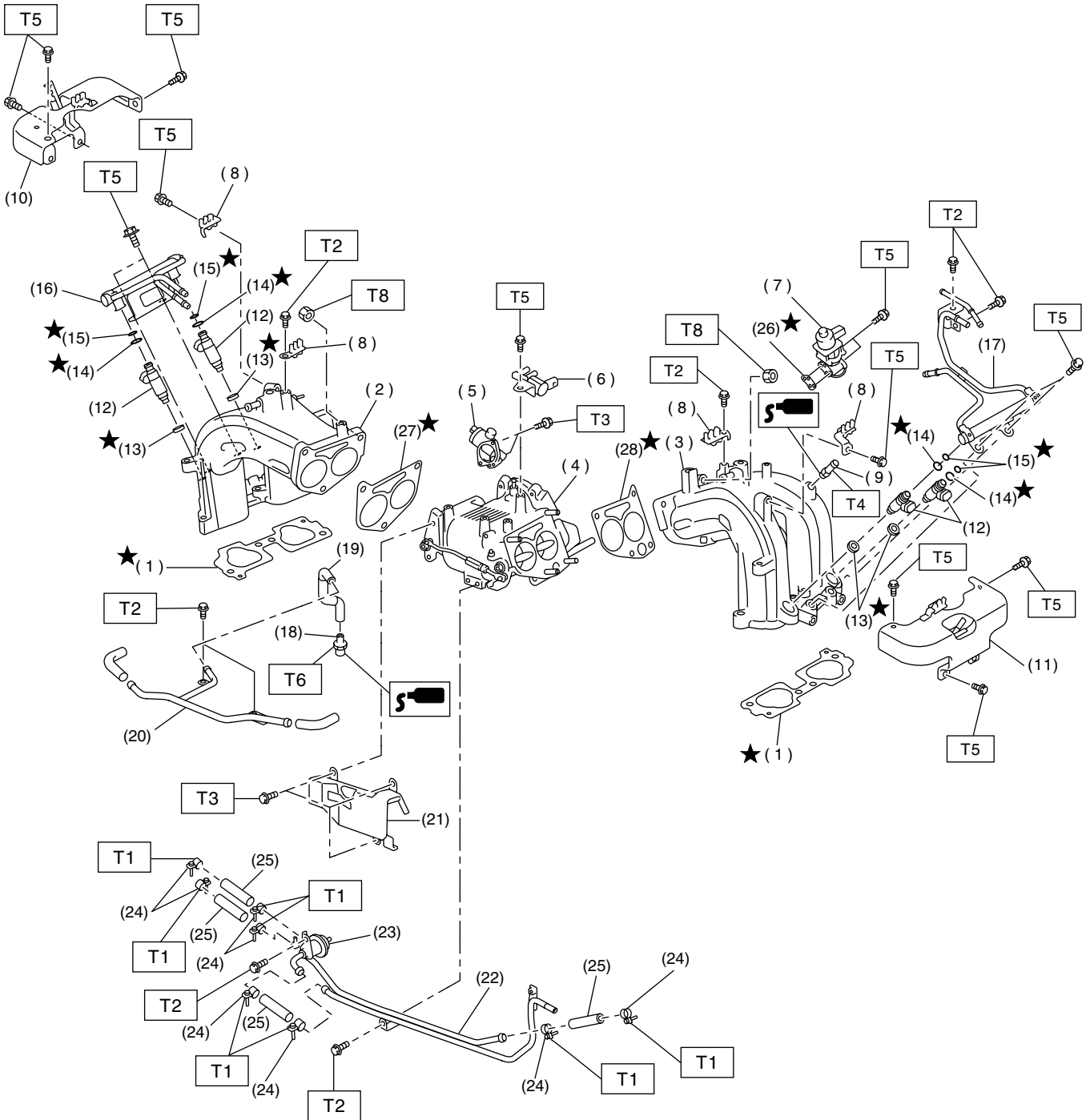

FU-01248

FU(H4SO U5)-4

# GENERAL DESCRIPTION

## FUEL INJECTION (FUEL SYSTEMS)

---

(1) Intake manifold gasket	(14) O-ring	(27) Tumble generator valve gasket RH
(2) Intake manifold RH	(15) O-ring	(28) Tumble generator valve gasket LH
(3) Intake manifold LH	(16) Fuel injector pipe RH	
(4) Tumble generator valve ASSY	(17) Fuel injector pipe LH	
(5) Tumble generator valve actuator	(18) PCV valve	
(6) Purge control solenoid valve	(19) PCV hose	
(7) EGR valve	(20) PCV pipe	
(8) Plug code holder	(21) Protector	
(9) Nipple	(22) Fuel pipe ASSY	
(10) Fuel pipe protector RH	(23) Pressure regulator	
(11) Fuel pipe protector LH	(24) Clamp	
(12) Fuel injector	(25) Fuel hose	
(13) O-ring	(26) EGR valve gasket	

---

**Tightening torque: N·m (kgf-m, ft-lb)****T1: 1.5 (0.15, 1.1)****T2: 5.0 (0.51, 3.7)****T3: 5.9 (0.60, 4.3)****T4: 17 (1.7, 12)****T5: 19 (0.19, 1.4)****T6: 22.5 (2.29, 16.6)****T7: 25 (2.6, 18.8)****T8: <Ref. to FU(H4SO U5)-23,  
ASSEMBLY, INTAKE  
MANIFOLD.>**

---

# GENERAL DESCRIPTION

FUEL INJECTION (FUEL SYSTEMS)

## 2. AIR INTAKE SYSTEM

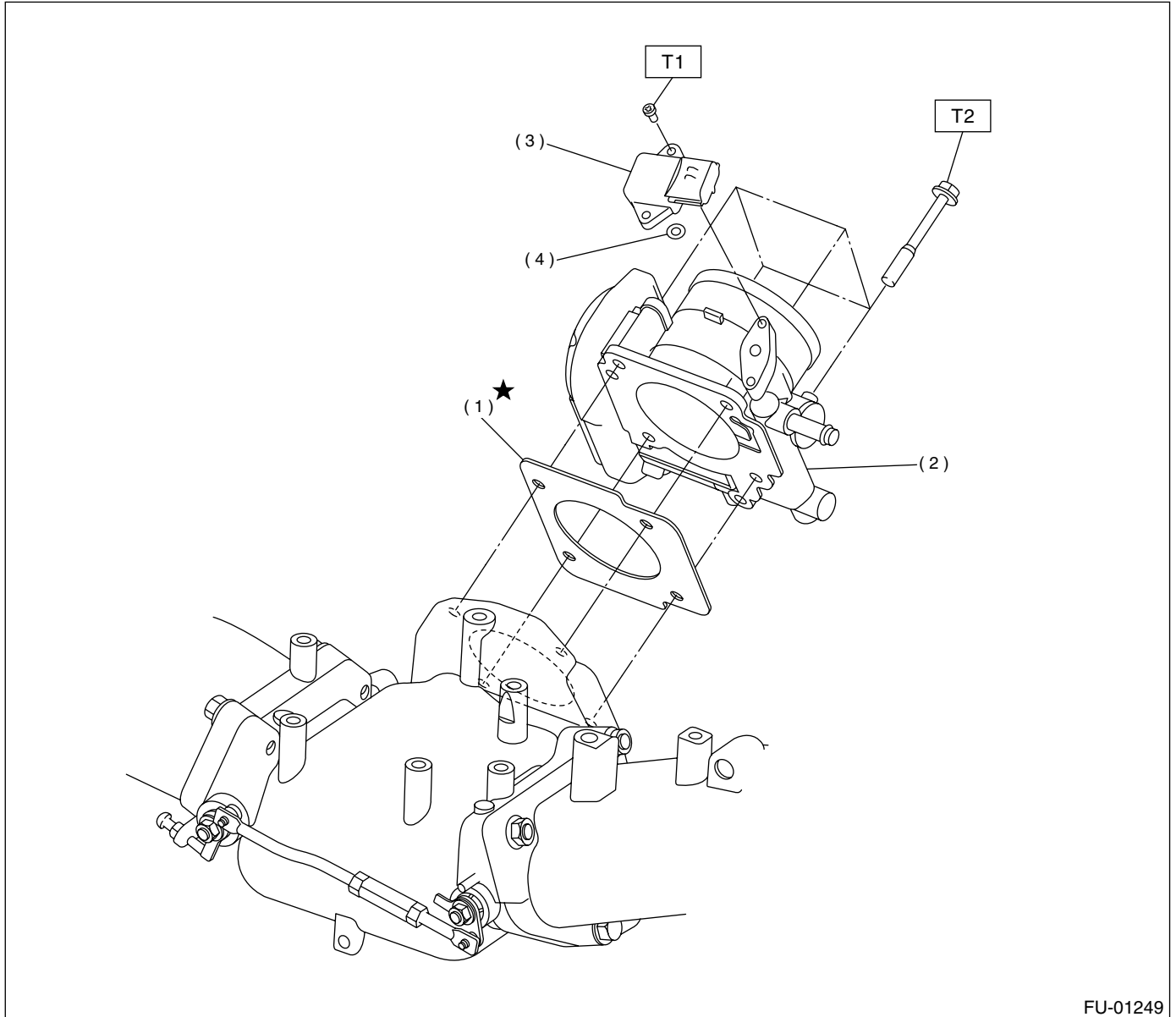

FU-01249

- (1) Gasket
- (2) Throttle body

- (3) Pressure sensor
- (4) O-ring

**Tightening torque: N·m (kgf·m, ft·lb)**

**T1: 1.6 (0.16, 1.2)**

**T2: 8 (0.8, 5.8)**

**FU(H4SO U5)-6**

# GENERAL DESCRIPTION

FUEL INJECTION (FUEL SYSTEMS)

## 3. CRANKSHAFT POSITION, CAMSHAFT POSITION AND KNOCK SENSORS

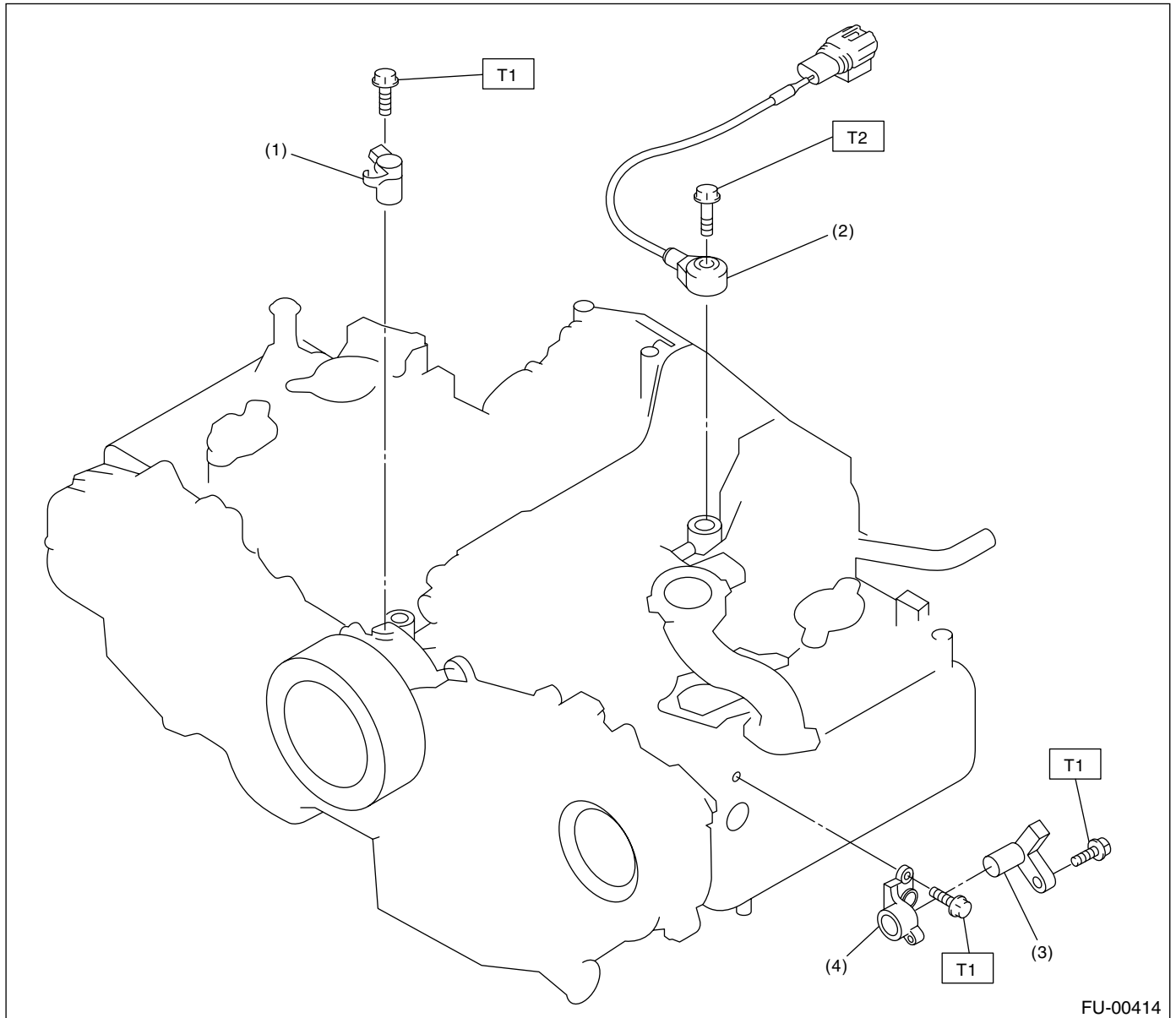

- (1) Crankshaft position sensor
- (2) Knock sensor

- (3) Camshaft position sensor
- (4) Camshaft position sensor support

**Tightening torque:** N·m (*kgf-m, ft-lb*)

**T1: 6.4 (0.65, 4.7)**

**T2: 24 (2.4, 17.4)**

# GENERAL DESCRIPTION

## FUEL INJECTION (FUEL SYSTEMS)

### 4. FUEL TANK

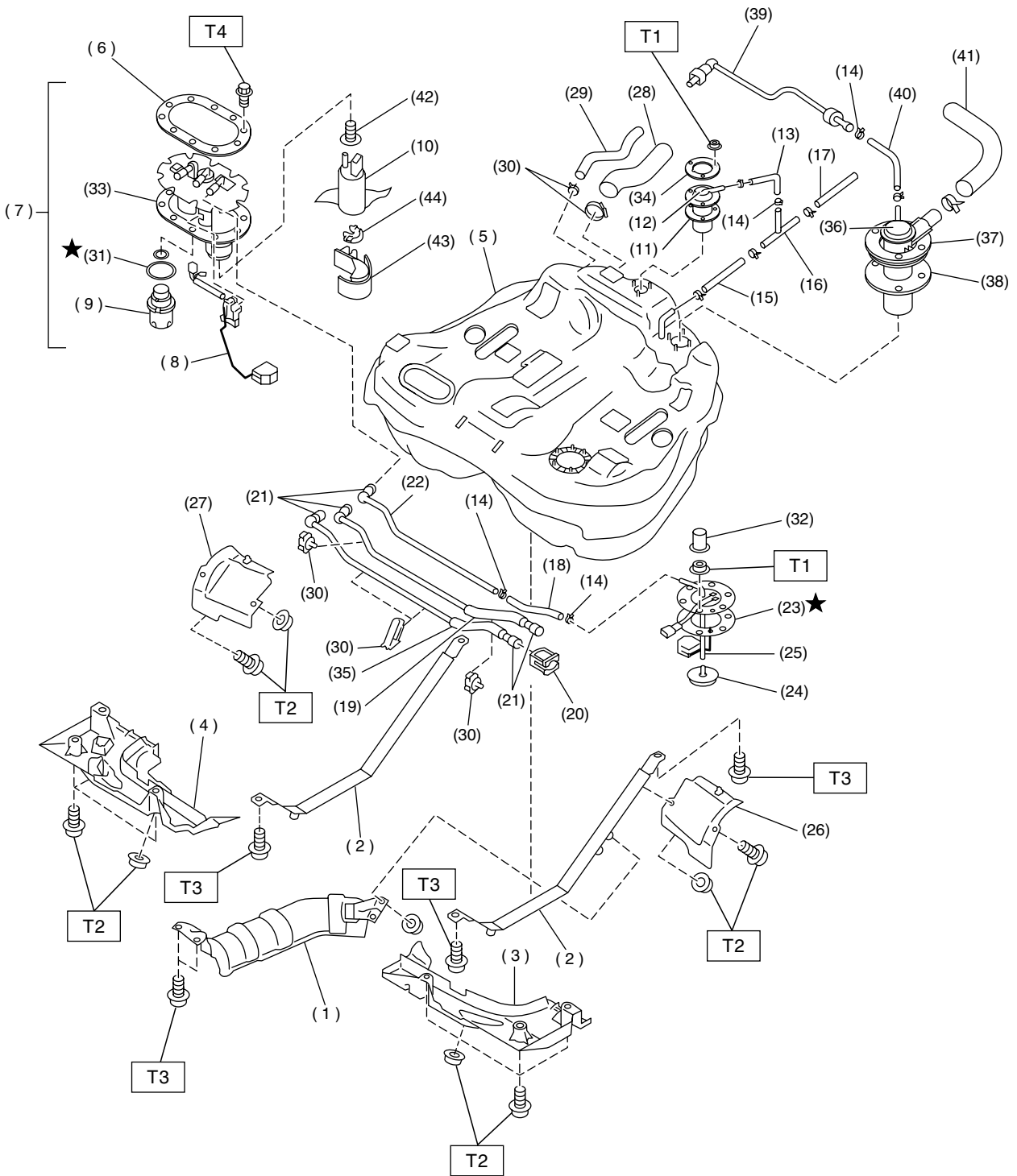

FU-02006



# GENERAL DESCRIPTION

## FUEL INJECTION (FUEL SYSTEMS)

---

(1) Heat sealed cover	(18) Jet pump hose	(35) Fuel delivery tube
(2) Fuel tank band	(19) Fuel return tube	(36) Vent valve
(3) Protector LH (Front)	(20) Retainer	(37) Vent valve plate
(4) Protector RH (Front)	(21) Quick connector	(38) Vent valve gasket
(5) Fuel tank	(22) Jet pump tube	(39) Evaporation tube
(6) Fuel pump plate	(23) Fuel sub level sensor gasket	(40) Evaporation hose D
(7) Fuel pump ASSY	(24) Jet pump filter	(41) Air vent hose
(8) Fuel level sensor	(25) Fuel sub level sensor	(42) Seal
(9) Fuel filter	(26) Protector LH (Rear)	(43) Fuel pump holder
(10) Fuel pump	(27) Protector RH (Rear)	(44) Grommet
(11) Fuel cut valve gasket	(28) Fuel filler hose	
(12) Fuel cut valve	(29) Fuel tank pressure sensor hose	
(13) Evaporation hose A	(30) Clamp	
(14) Clip	(31) Gasket	
(15) Evaporation hose C	(32) Cap	
(16) Joint pipe	(33) Gasket	
(17) Evaporation hose B	(34) Fuel cut valve plate	

---

**Tightening torque:** N·m (**kgf-m, ft-lb**)

**T1: 4.4 (0.45, 3.3)**

**T2: 18 (1.8, 13.0)**

**T3: 33 (3.4, 25)**

**T4: 5.9 (0.6, 4.3)**

---

# GENERAL DESCRIPTION

## FUEL INJECTION (FUEL SYSTEMS)

### 5. FUEL LINE

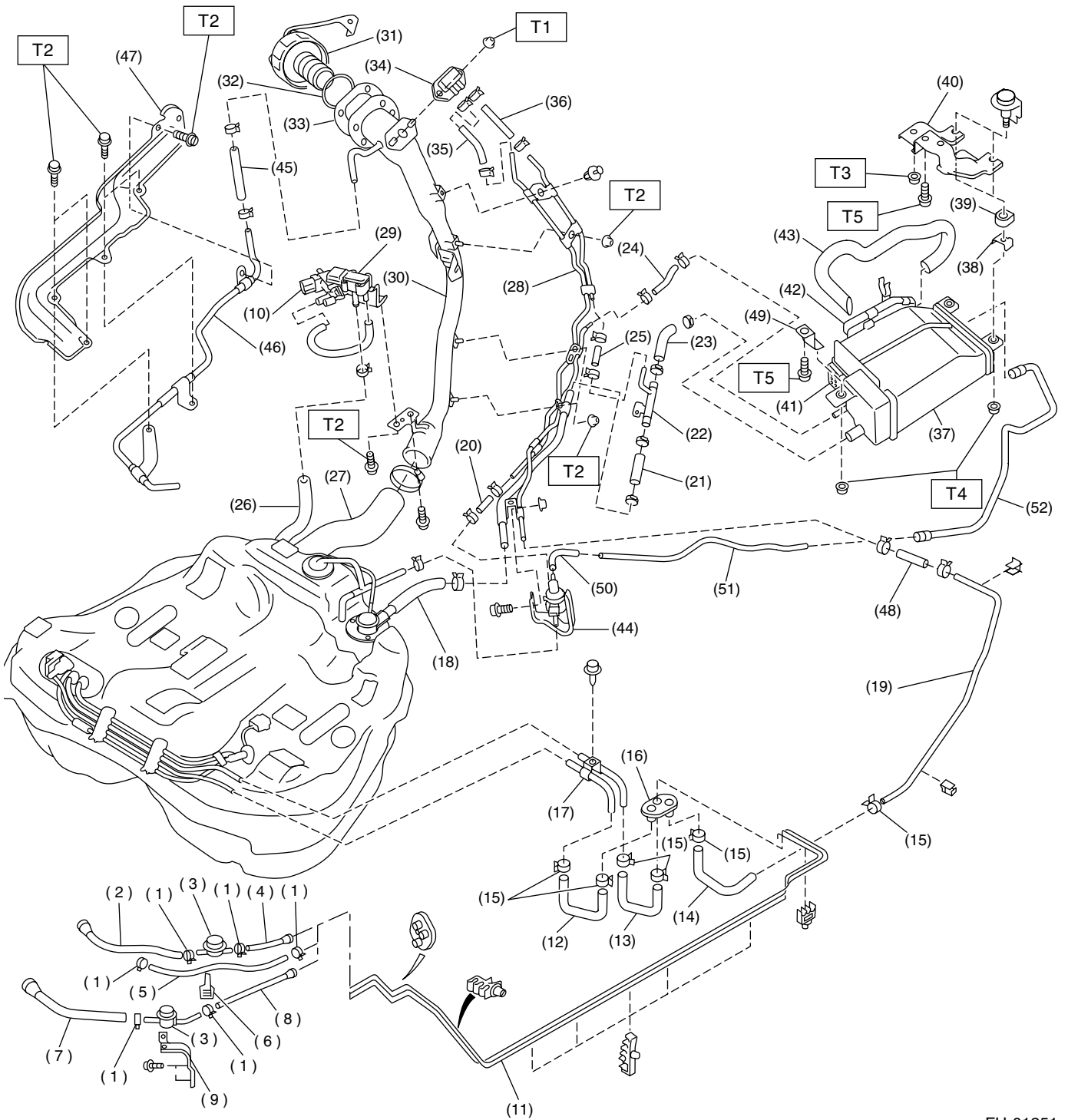

FU-01251

# GENERAL DESCRIPTION

## FUEL INJECTION (FUEL SYSTEMS)

---

(1) Clamp	(21) Air vent hose B	(41) Drain valve
(2) Fuel return hose A	(22) Air vent pipe	(42) Drain filter
(3) Fuel damper valve	(23) Air vent hose C	(43) Drain hose
(4) Fuel return hose B	(24) Evaporation hose D	(44) Pressure control solenoid valve
(5) Evaporation hose A	(25) Evaporation hose E	(45) Evaporation hose H
(6) Clip	(26) Fuel tank pressure sensor hose	(46) Evaporation pipe C
(7) Fuel delivery hose A	(27) Fuel filler hose	(47) Pipe protector
(8) Fuel delivery hose B	(28) Evaporation pipe B	(48) Evaporation hose I
(9) Fuel dumper valve bracket	(29) Fuel tank pressure sensor	(49) Canister bracket (front)
(10) Fuel tank sensor control valve	(30) Fuel filler pipe	(50) PCV hose
(11) Fuel pipe ASSY	(31) Fuel filler cap	(51) PCV pipe
(12) Fuel delivery hose C	(32) Ring	(52) PCV tube
(13) Fuel return hose C	(33) Packing	
(14) Evaporation hose B	(34) Shut valve	
(15) Clamp	(35) Evaporation hose F	
(16) Grommet	(36) Evaporation hose G	
(17) Fuel pipe ASSY	(37) Canister	
(18) Air vent hose A	(38) Canister lower bracket	
(19) Evaporation pipe A	(39) Cushion rubber	
(20) Evaporation hose C	(40) Canister upper bracket	

---

**Tightening torque: N·m (kgf-m, ft-lb)**

**T1: 4.5 (0.46, 3.3)**

**T2: 7.5 (0.76, 5.5)**

**T3: 18 (1.8, 13.0)**

**T4: 23 (2.3, 16.6)**

**T5: 33 (3.4, 25)**

---

# GENERAL DESCRIPTION

## FUEL INJECTION (FUEL SYSTEMS)

### 6. FUEL FILLER PIPE

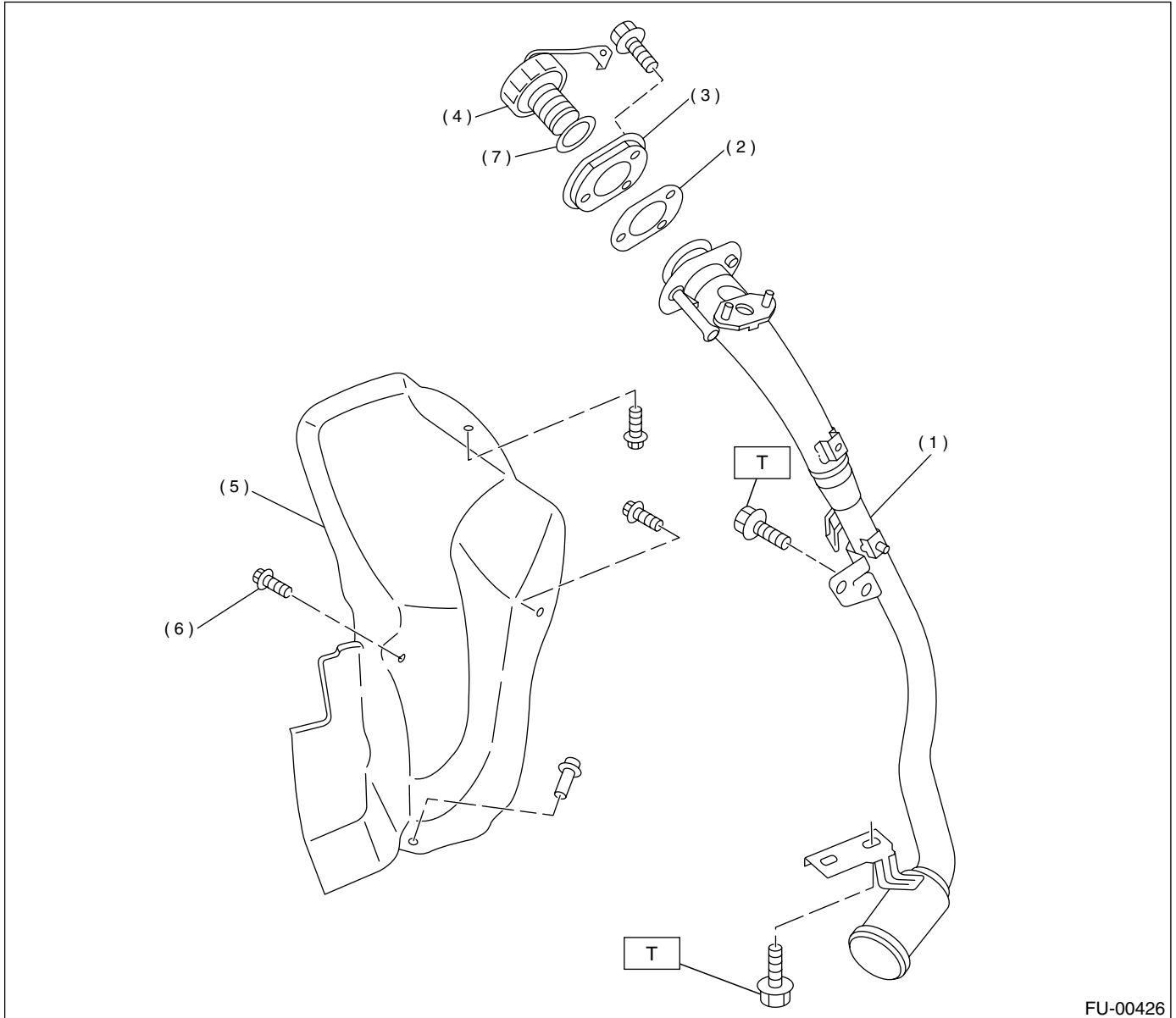

- (1) Fuel filler pipe ASSY
- (2) Filler pipe packing
- (3) Filler ring
- (4) Filler cap
- (5) Filler pipe protector
- (6) Clip
- (7) O-ring

**Tightening torque: N·m (kgf-m, ft-lb)**

**T: 7.5 (0.75, 5.4)**

# GENERAL DESCRIPTION



## FUEL INJECTION (FUEL SYSTEMS)

### C: CAUTION

- Wear working clothing, including a cap, protective goggles, and protective shoes during operation.
- Remove contamination including dirt and corrosion before removal, installation or disassembly.
- Keep the disassembled parts in order and protect them from dust or dirt.
- Before removal, installation or disassembly, be sure to clarify the failure. Avoid unnecessary removal, installation, disassembly, and replacement.

- Be careful not to burn your hands, because each part on the vehicle is hot after running.
- Be sure to tighten fasteners including bolts and nuts to the specified torque.
- Place shop jacks or safety stands at the specified points.
- Before disconnecting electrical connectors of sensors or units, be sure to disconnect ground cable from battery.
- Place “NO FIRE” signs near the working area.
- Be careful not to spill fuel on the floor.

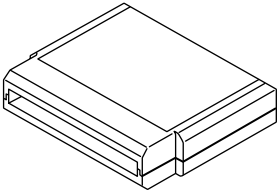
### D: PREPARATION TOOL

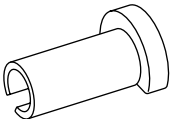
ILLUSTRATION	TOOL NUMBER	DESCRIPTION	REMARKS
 <p>ST24082AA230</p>	24082AA230	CARTRIDGE	Troubleshooting for electrical systems.
 <p>ST22771AA030</p>	22771AA030	SELECT MONITOR KIT	Troubleshooting for electrical systems.
 <p>ST42099AE000</p>	42099AE000	CONNECTOR REMOVER	Used for removing quick connector in engine room.

# THROTTLE BODY

FUEL INJECTION (FUEL SYSTEMS)

## 2. Throttle Body

### A: REMOVAL

1) Disconnect battery ground cable.

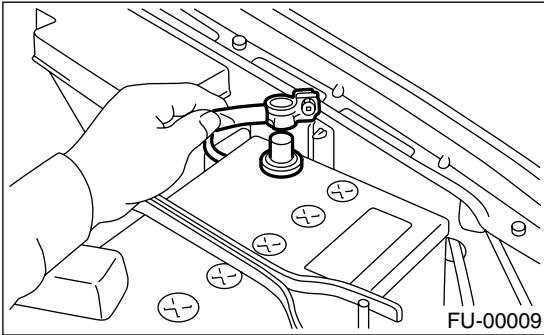

2) Remove air intake chamber.

<Ref. to IN(H4SO U5)-6, REMOVAL, Air Intake Chamber.>

3) Disconnect connectors from throttle position sensor and pressure sensor.

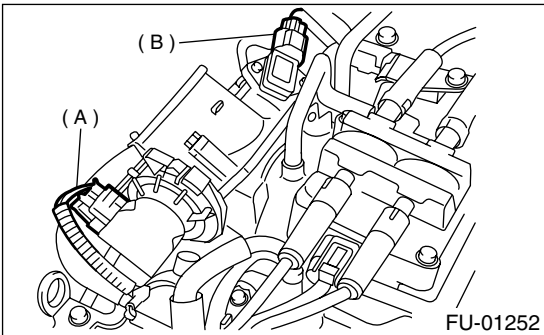

(A) Throttle position sensor

(B) Pressure sensor

4) Disconnect engine coolant hoses (A) from throttle body.

5) Remove bolts (B) which install throttle body to intake manifold.

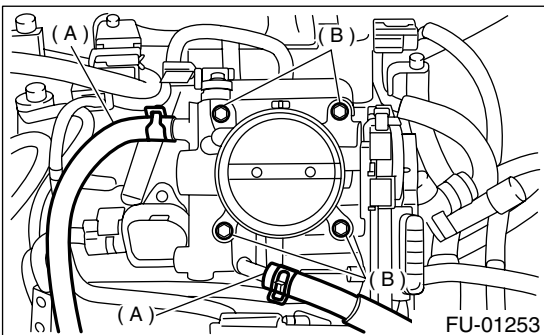

### B: INSTALLATION

Install in the reverse order of removal.

NOTE:

Always use a new gasket.

**Tightening torque:**

**Throttle body;**

**8 N·m (0.8 kgf-m, 5.8 ft-lb)**

### 3. Intake Manifold

#### A: REMOVAL

- 1) Release fuel pressure. <Ref. to FU(H4SO U5)-53, RELEASING OF FUEL PRESSURE, OPERATION, Fuel.>
- 2) Open fuel flap lid, and remove fuel filler cap.
- 3) Disconnect battery ground cable.

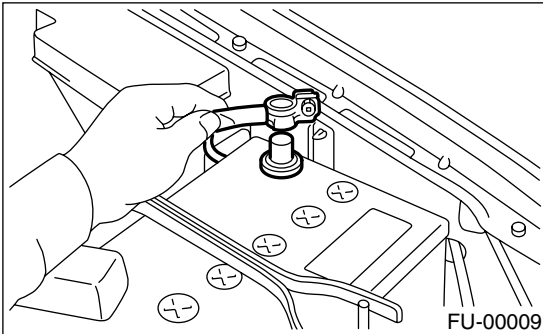

- 4) Remove air cleaner case and air intake chamber. <Ref. to IN(H4SO U5)-5, REMOVAL, Air Cleaner Case.> and <Ref. to IN(H4SO U5)-6, REMOVAL, Air Intake Chamber.>
- 5) Remove power steering pump and tank from brackets.

- (1) Remove air intake duct. <Ref. to IN(H4SO U5)-7, REMOVAL, Air Intake Duct.>
- (2) Remove front V-belt. <Ref. to ME(H4SO)-43, REMOVAL, V-belt.>
- (3) Remove bolts which hold power steering pipes onto intake manifold protector.

#### NOTE:

Do not disconnect power steering hose.

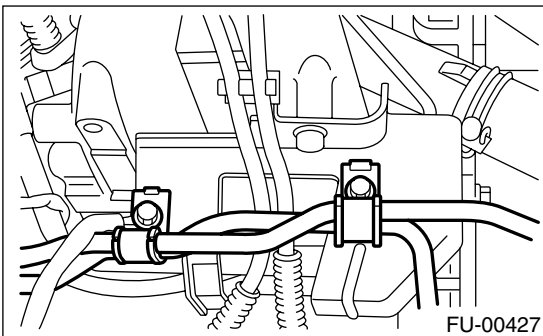

- (4) Remove bolts which install power steering pump bracket.

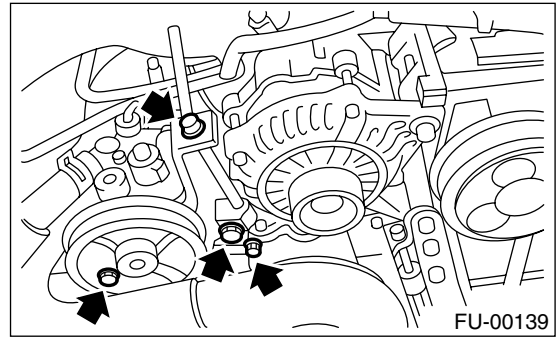

- (5) Disconnect connector from power steering pump switch.

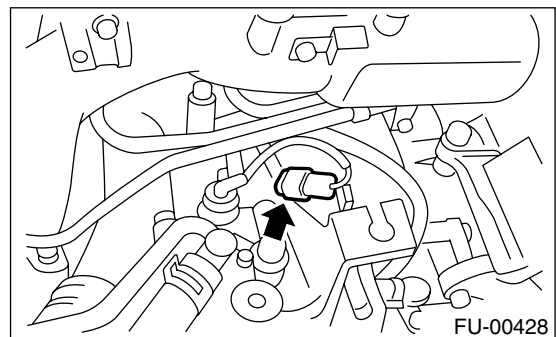

- (6) Remove power steering tank from the bracket by pulling it upwards.

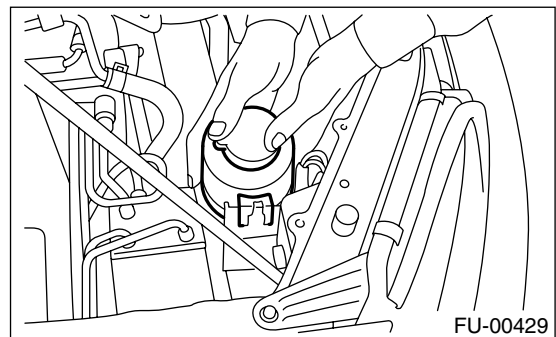

- (7) Place power steering pump and tank on the right side wheel apron.

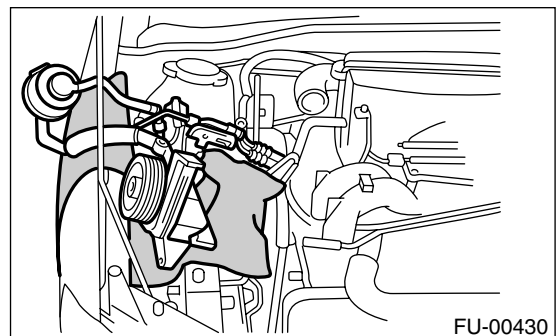

- 6) Disconnect spark plug cords from spark plugs.

# INTAKE MANIFOLD

## FUEL INJECTION (FUEL SYSTEMS)

7) Disconnect PCV hose from intake manifold.

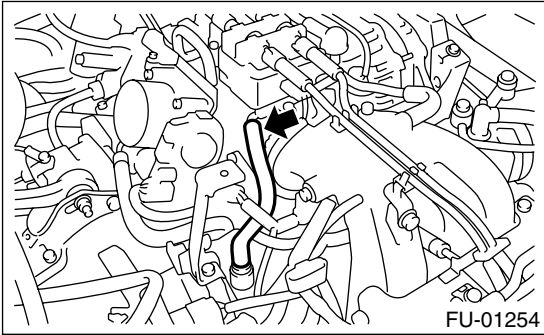

8) Disconnect engine coolant hose (A) from throttle body.

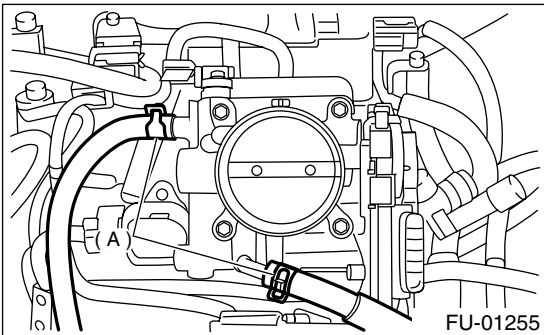

9) Disconnect brake booster hose.

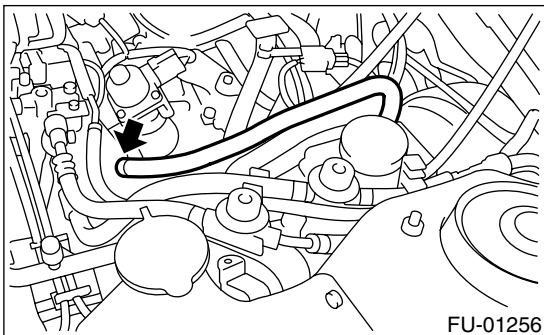

10) Remove air intake chamber stay RH and engine harness bracket, and disconnect engine harness connectors from bulkhead harness connectors.

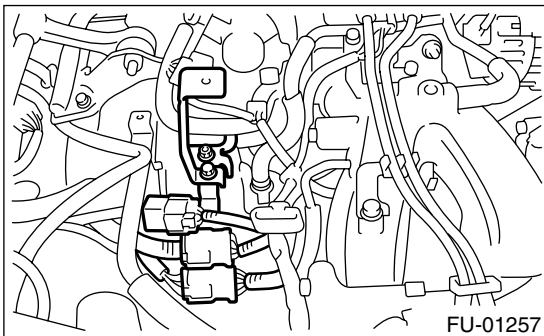

11) Disconnect knock sensor connector.

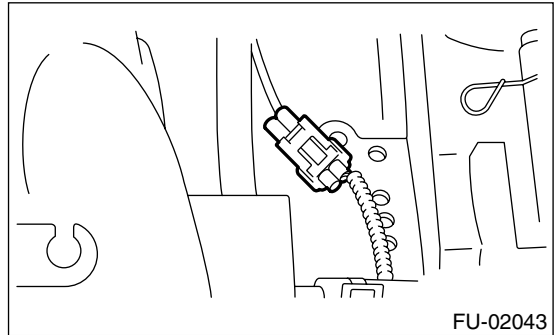

12) Disconnect connector from crankshaft position sensor.

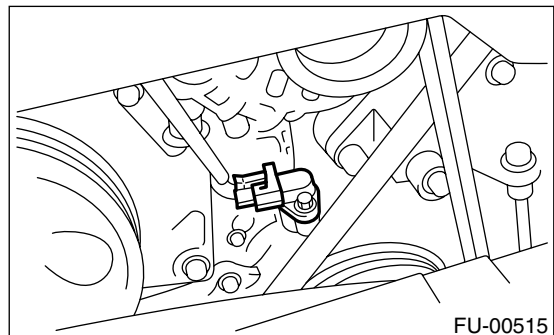

13) Disconnect connector from oil pressure switch.

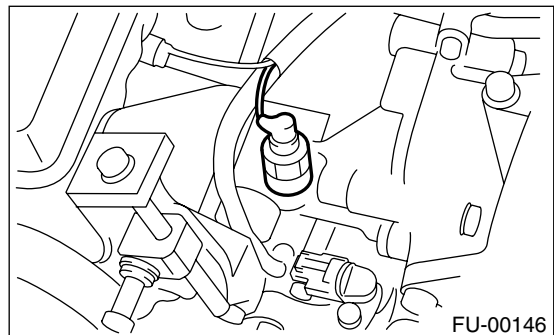

14) Disconnect connector from camshaft position sensor.

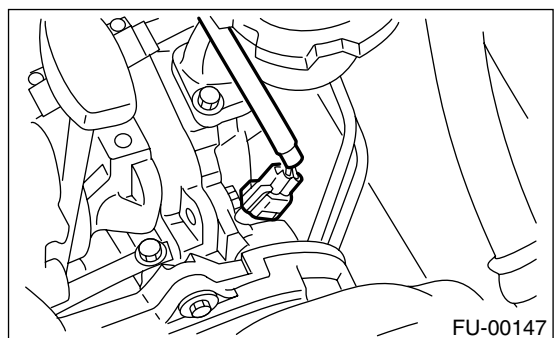



# INTAKE MANIFOLD

FUEL INJECTION (FUEL SYSTEMS)

15) Disconnect connectors from front oxygen (A/F) sensor.

- LH side

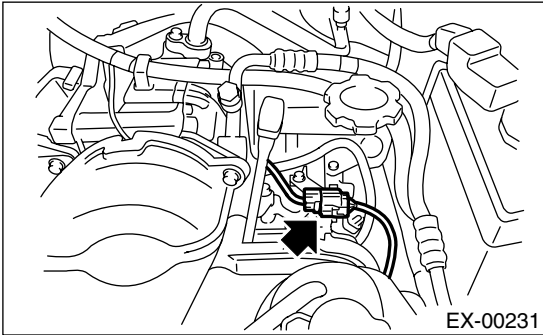

- RH side

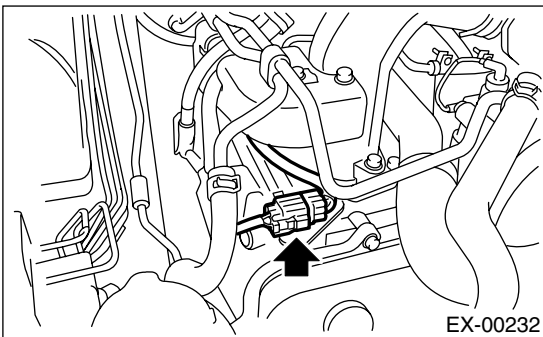

16) Disconnect connectors from engine coolant temperature sensor.

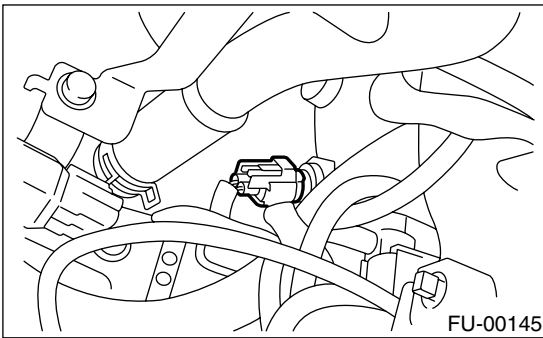

17) Remove EGR pipe from intake manifold and cylinder head.

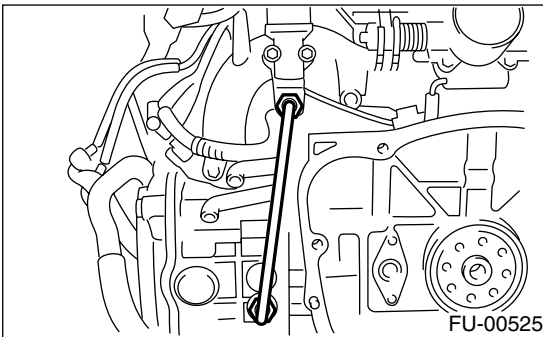

18) Using the ST, disconnect fuel hoses from fuel pipes.

### WARNING:

- Do not spill fuel.
- Catch fuel from hoses in a container or cloth.

ST 42099AE000 CONNECTOR REMOVER

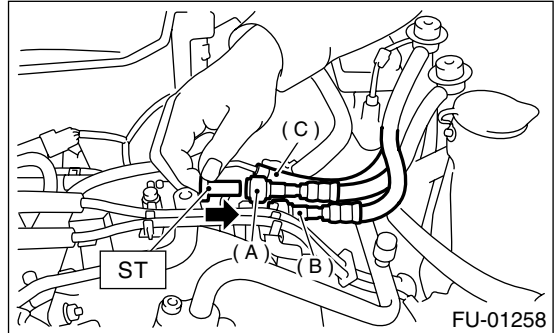

- (A) Fuel delivery hose
- (B) Fuel return hose
- (C) Evaporation hose

19) Remove bolts which hold intake manifold onto cylinder heads, and remove intake manifold.

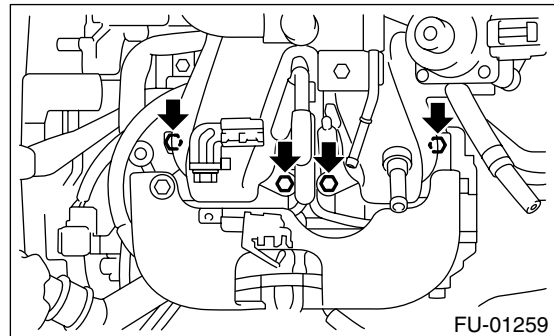

## B: INSTALLATION

1) Install intake manifold onto cylinder heads.

### NOTE:

Always use new gaskets.

### Tightening torque:

**25 N·m (2.5 kgf-m, 18.1 ft-lb)**

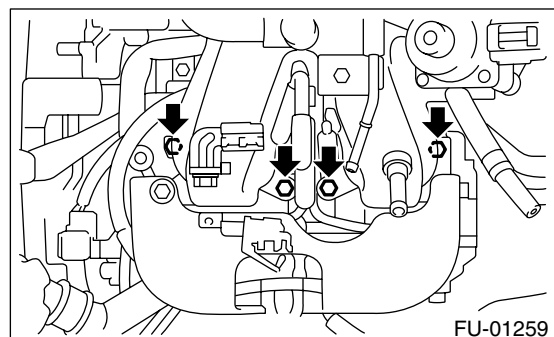

# INTAKE MANIFOLD

## FUEL INJECTION (FUEL SYSTEMS)

2) Connect fuel hoses.

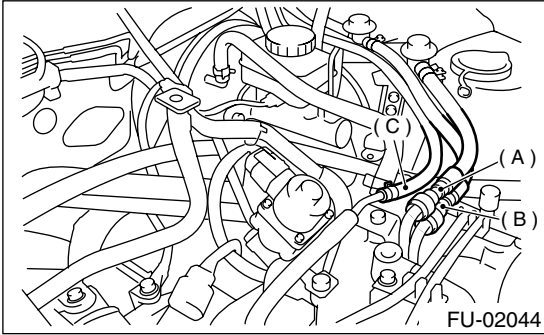

- (A) Fuel delivery hose
- (B) Fuel return hose
- (C) Evaporation hose

3) Install EGR pipe to intake manifold and cylinder head.

**Tightening torque:**

**34 N·m (3.5 kgf-m, 25 ft-lb)**

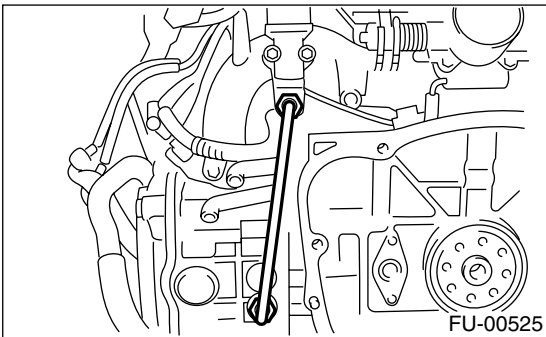

4) Connect connectors to engine coolant temperature sensor.

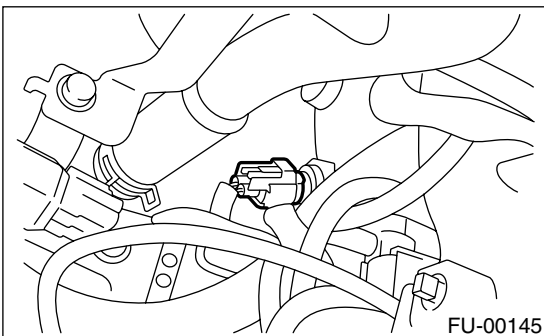

5) Connect connectors to front oxygen (A/F) sensor.

- LH side

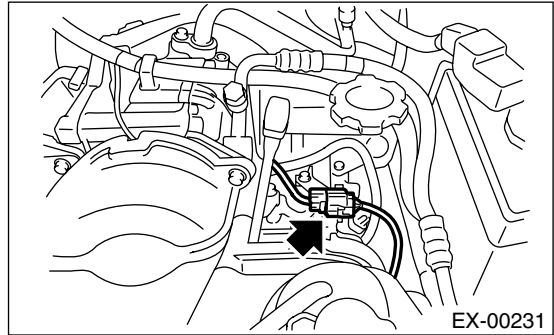

- RH side

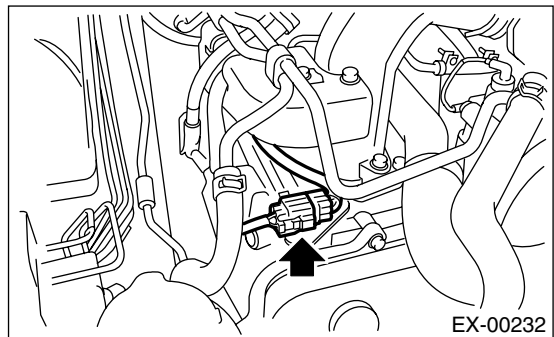

6) Connect connector to camshaft position sensor.

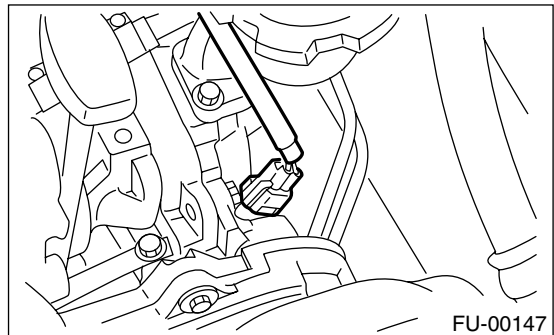

7) Connect connector to oil pressure switch.

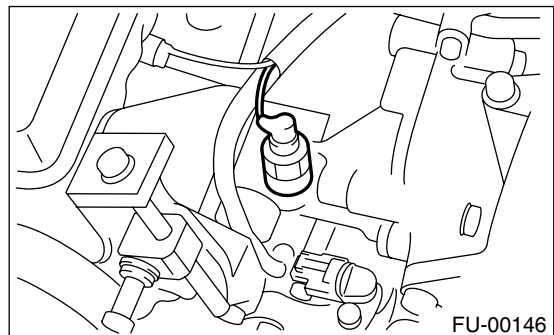

# INTAKE MANIFOLD

## FUEL INJECTION (FUEL SYSTEMS)

8) Connect connector to crankshaft position sensor.

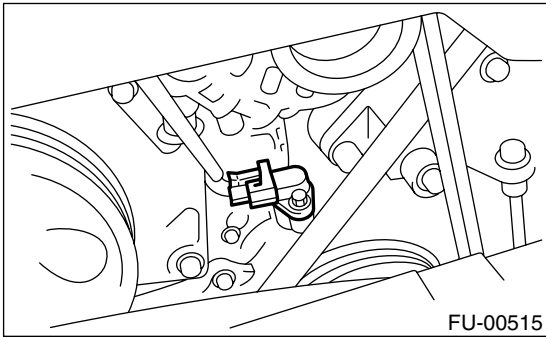

9) Connect knock sensor connector.

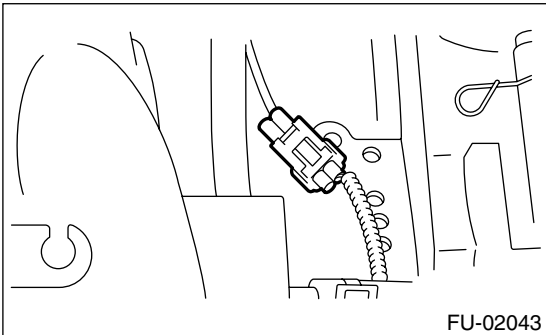

10) Install air intake chamber stay RH and engine harness bracket, and connect engine harness connectors to bulkhead connectors.

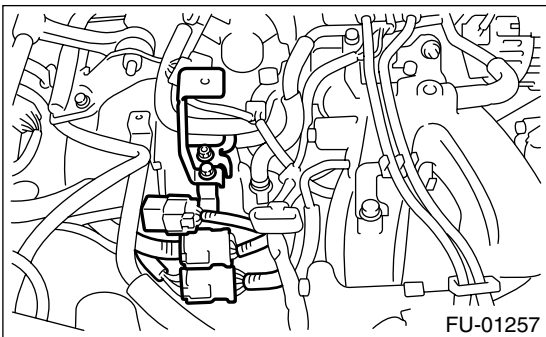

11) Connect brake booster hose.

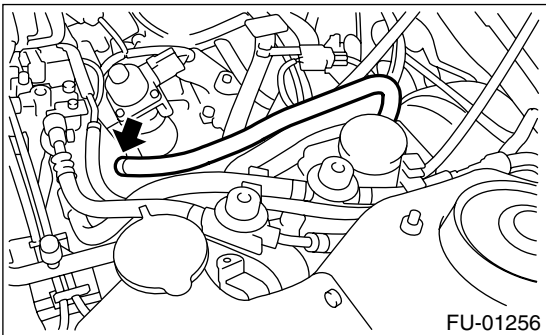

12) Connect engine coolant hose (A) to throttle body.

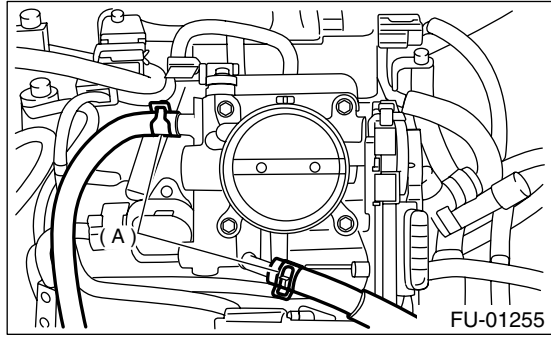

13) Connect PCV hose to intake manifold.

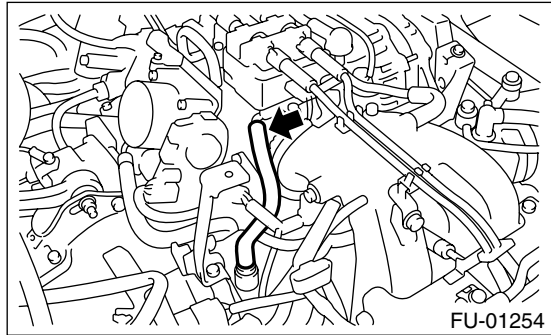

14) Connect spark plug cords to spark plugs.  
15) Install power steering pump and tank on brackets.

(1) Install power steering tank on bracket.

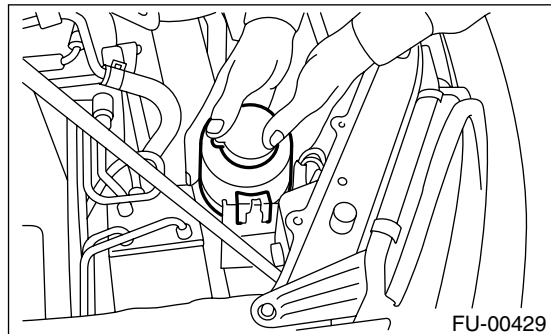

(2) Connect connector to power steering pump switch.

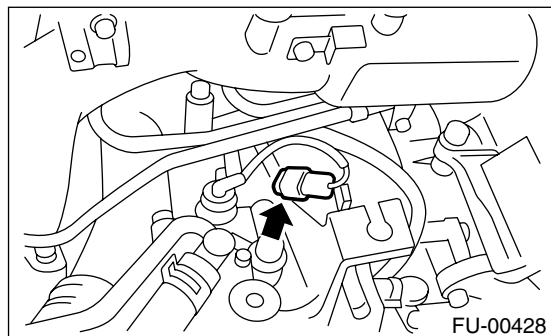

# INTAKE MANIFOLD

## FUEL INJECTION (FUEL SYSTEMS)

(3) Tighten bolts which install power steering pump on bracket.

### Tightening torque:

**22 N·m (2.2 kgf·m, 15.9 ft·lb)**

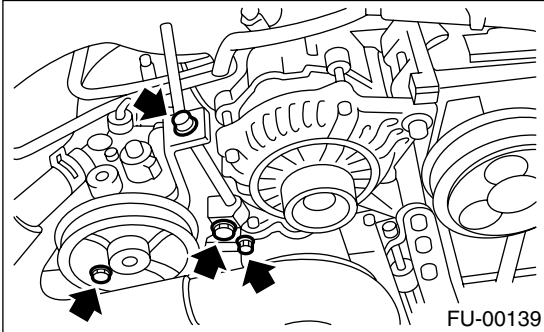

(4) Install power steering pipes onto right side intake manifold protector.

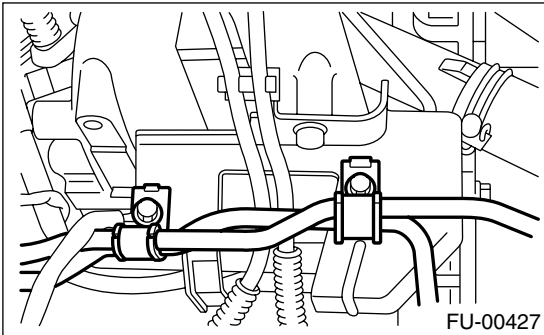

(5) Install front V-belt.

<Ref. to ME(H4SO)-43, INSTALLATION, V-belt.>

(6) Install air intake duct.

16) Install air cleaner case and air intake chamber.  
<Ref. to IN(H4SO U5)-5, INSTALLATION, Air Cleaner Case.> and <Ref. to IN(H4SO U5)-6, INSTALLATION, Air Intake Chamber.>

17) Connect connector to fuel pump relay.

18) Connect battery ground cable.

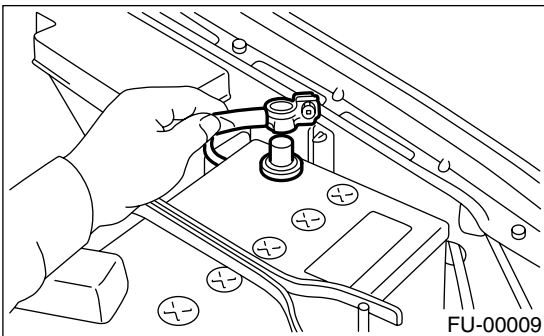

## C: DISASSEMBLY

1) Disconnect engine ground terminal from intake manifold.

- LH side

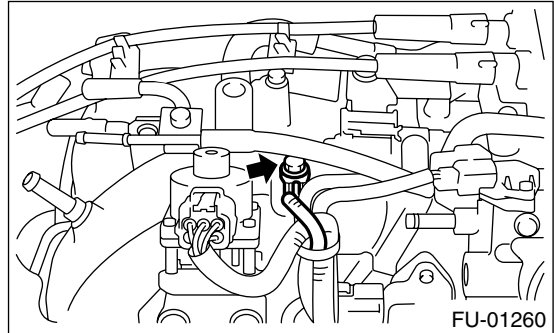

- RH side

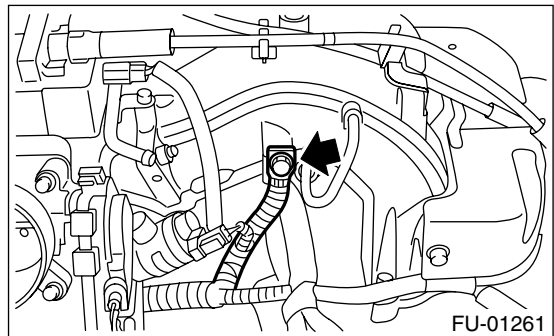

2) Remove ignition coil and ignitor assembly. <Ref. to IG(H4SO)-7, REMOVAL, Ignition Coil and Ignitor Assembly.>

3) Remove throttle body.

<Ref. to FU(H4SO U5)-14, REMOVAL, Throttle Body.>

4) Remove EGR valve.

<Ref. to FU(H4SO U5)-37, REMOVAL, EGR Valve.>

5) Remove PCV pipe.

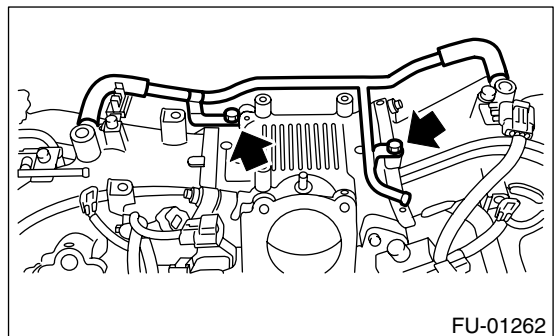

# INTAKE MANIFOLD

FUEL INJECTION (FUEL SYSTEMS)

6) Disconnect pressure regulator vacuum hose from intake manifold.

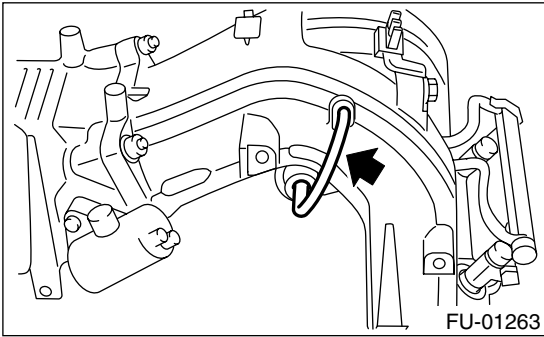

7) Remove fuel pipe protector LH.

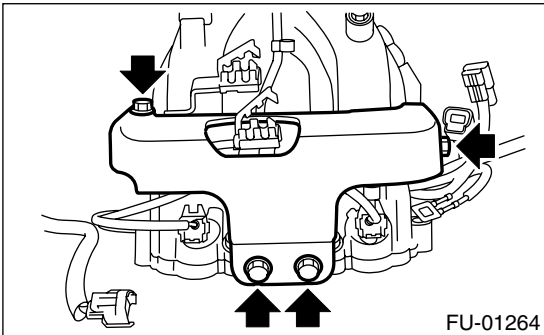

8) Remove fuel pipe protector RH.

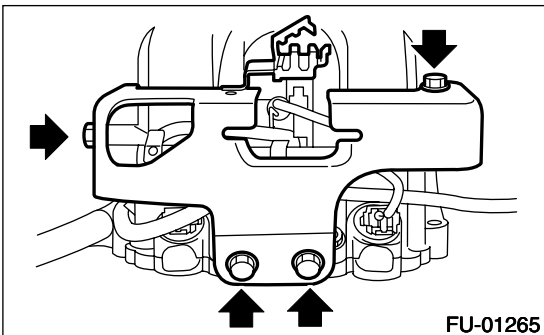

9) Disconnect connector (A) from fuel injector.

10) Remove harness band (B) which holds engine harness onto injector pipe.

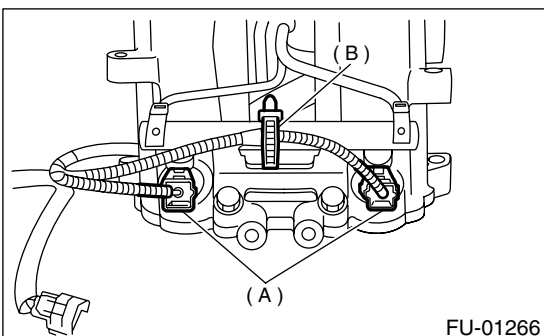

11) Remove tumble generator valve actuator. <Ref. to FU(H4SO U5)-35, REMOVAL, Tumble Generator Valve Actuator.>

12) Remove purge control solenoid valve. <Ref. to EC(H4SO)-6, REMOVAL, Purge Control Solenoid Valve.>

13) Remove harness bands which hold engine harness onto intake manifold.

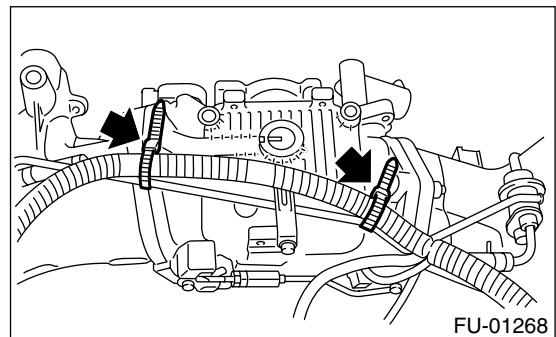
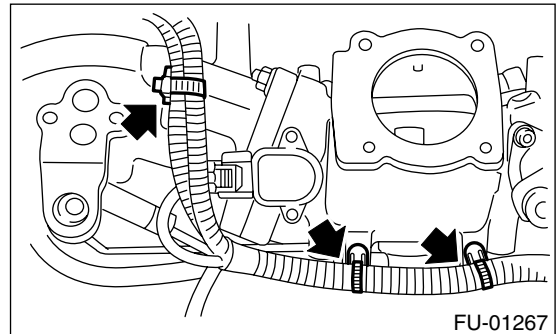

14) Remove engine harness from intake manifold.

15) Remove bolt which installs injector pipe on intake manifold as shown in figure.

- RH side

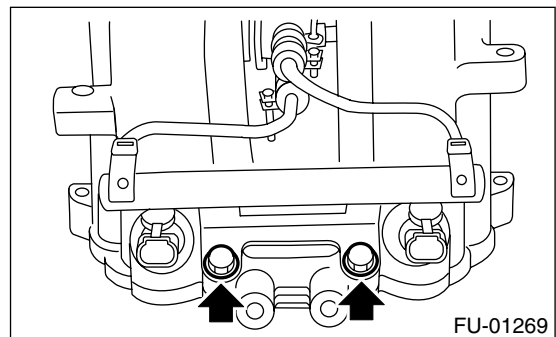

# INTAKE MANIFOLD

## FUEL INJECTION (FUEL SYSTEMS)

- LH side

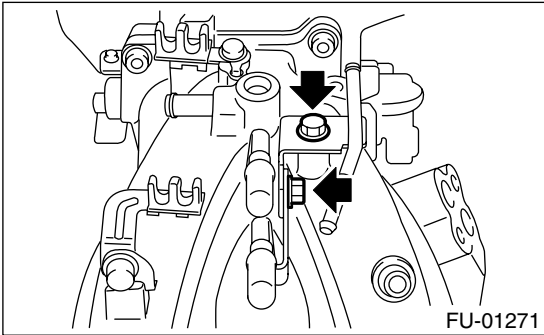
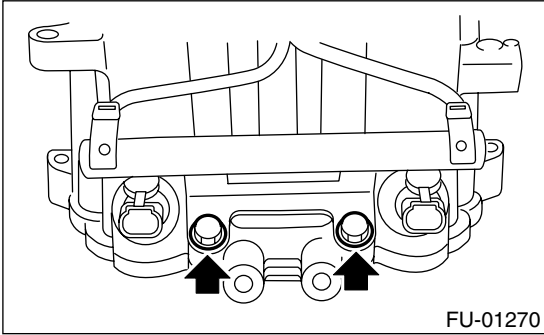

16) Remove fuel injectors.

17) Loosen the clamp which holds fuel injector pipe RH onto fuel hose, and disconnect the pipe from fuel hose.

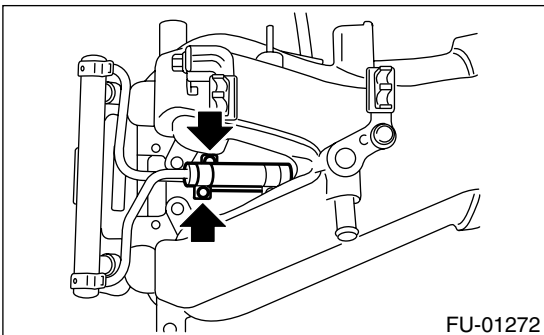

18) Loosen the clamp which holds fuel injector pipe LH onto fuel hose, and disconnect the pipe from fuel hose.

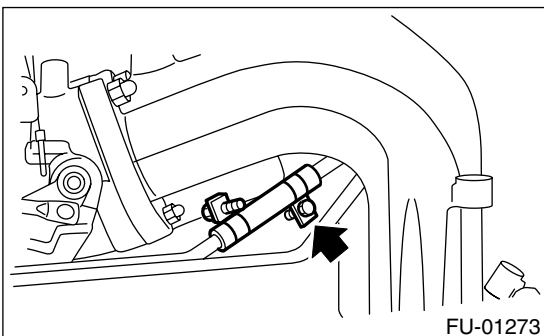

19) Remove bolt which installs fuel pipe on intake manifold.

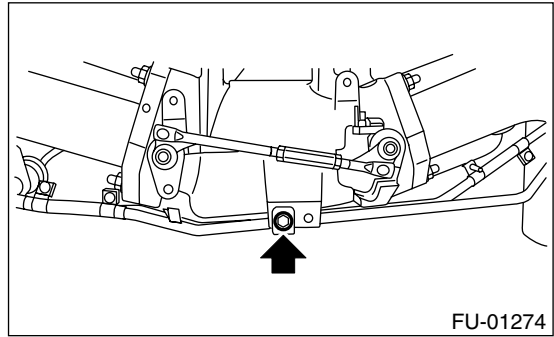

20) Remove bolt which install pressure regulator to intake manifold.

21) Remove intake manifold RH from tumble generator valve assembly.

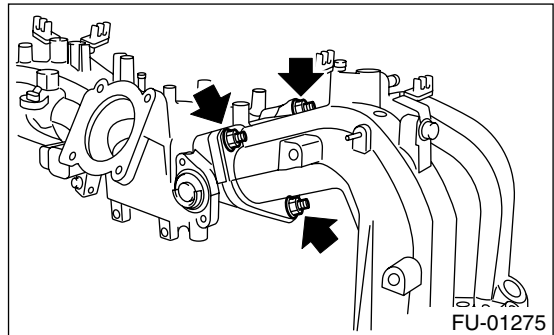

22) Similarly, remove intake manifold LH.

# INTAKE MANIFOLD

FUEL INJECTION (FUEL SYSTEMS)

## D: ASSEMBLY

1) Install intake manifold RH and LH to tumble generator valve assembly.

### NOTE:

Always use a new gasket.

### CAUTION:

**This work should be done on cylinder head. (Do not use gasket for the mating surface of cylinder head and intake manifold at this time.)**

- (1) Temporarily tighten (a) - (o) in alphabetical order.
- (2) Tighten (e) - (k) to 5 N·m (0.5 kgf-m, 4 ft-lb).
- (3) Tighten (a) - (d) and (l) - (o) to 10 N·m (1.0 kgf-m, 7 ft-lb).
- (4) Tighten (e) - (g) to 25 N·m (2.6 kgf-m, 18 ft-lb).
- (5) Tighten (h) - (k) to 25 N·m (2.6 kgf-m, 18 ft-lb).
- (6) Loosen (a) - (d) and (l) - (o) to remove.

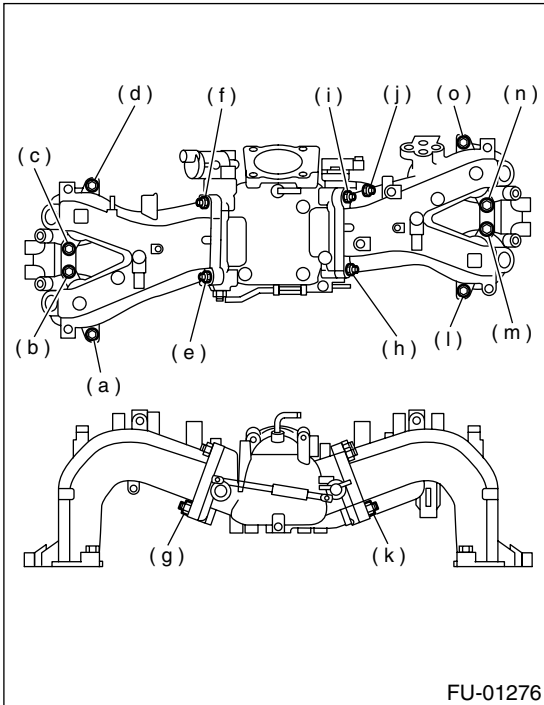

2) Tighten bolt which pressure regulator to intake manifold.

### Tightening torque:

**5.0 N·m (0.51 kgf-m, 3.7 ft-lb)**

3) Tighten bolt which installs fuel pipes on intake manifold.

### Tightening torque:

**5.0 N·m (0.51 kgf-m, 3.7 ft-lb)**

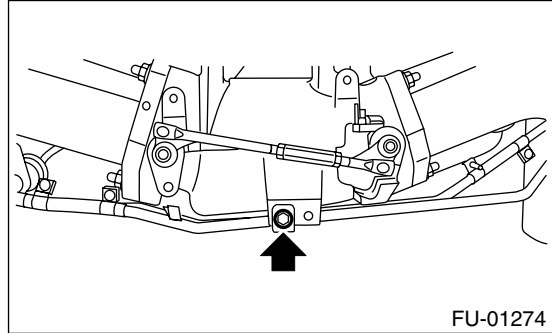

4) Connect fuel injector pipe to fuel hose, and tighten clamp screw.

### NOTE:

Tighten clamp screw as shown in the Figure below.

**L: 2 — 5 mm (0.08 — 0.20 in)**

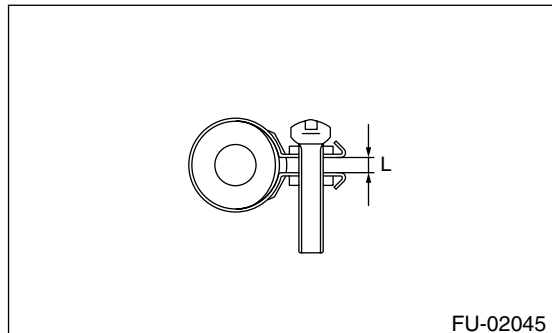

### Tightening torque:

**1.5 N·m (0.15 kgf-m, 1.1 ft-lb)**

- LH side

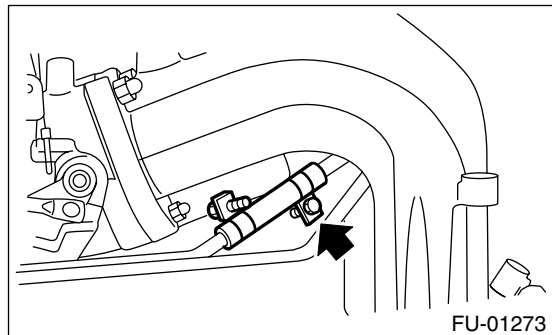

# INTAKE MANIFOLD

## FUEL INJECTION (FUEL SYSTEMS)

- RH side

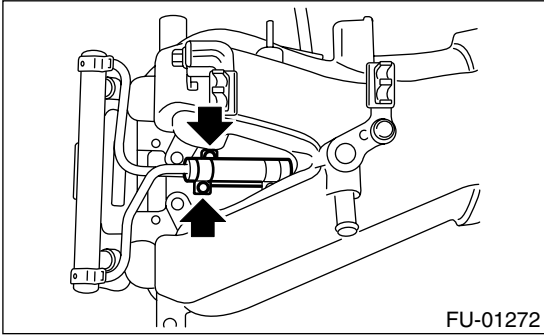

- 5) Install fuel injectors.
- 6) Tighten bolt which installs injector pipe on intake manifold.

- RH side

**Tightening torque:**  
**19 N·m (1.9 kgf-m, 13.7 ft-lb)**

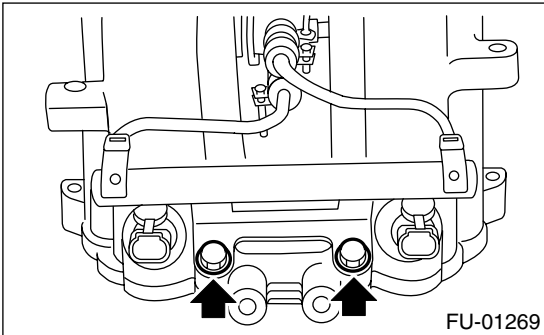

- LH side

**Tightening torque:**  
**19 N·m (1.9 kgf-m, 13.7 ft-lb)**

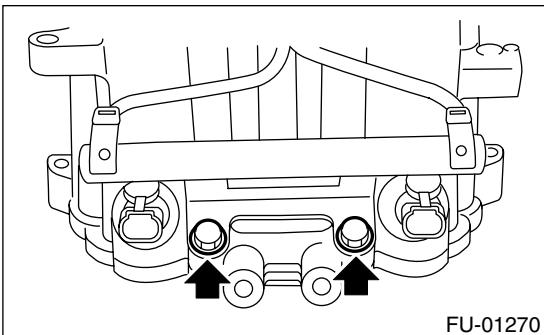

**Tightening torque:**  
**5.0 N·m (0.51 kgf-m, 3.7 ft-lb)**

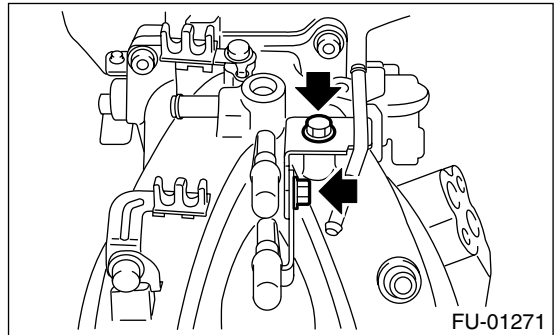

- 7) Hold engine harness by harness bands.

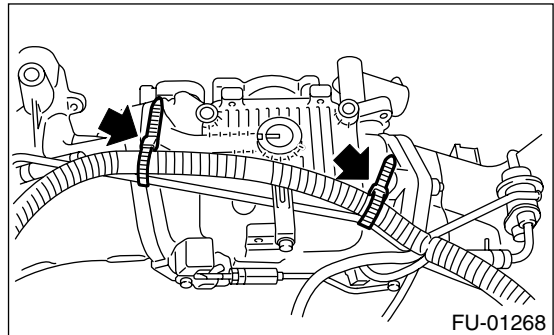
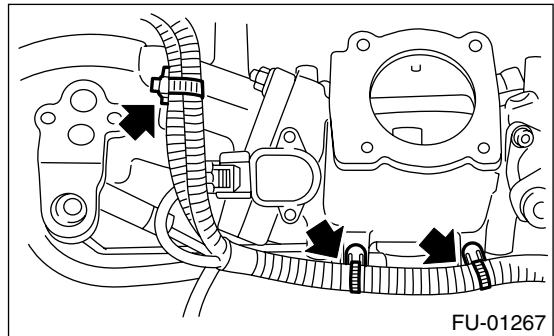

- 8) Install purge control solenoid valve. <Ref. to EC(H4SO)-6, INSTALLATION, Purge Control Solenoid Valve.>
- 9) Install tumble generator valve actuator. <Ref. to FU(H4SO U5)-35, INSTALLATION, Tumble Generator Valve Actuator.>
- 10) Connect connector (A) to fuel injector.



# INTAKE MANIFOLD

FUEL INJECTION (FUEL SYSTEMS)

11) Secure engine harness on injector pipe by harness band (B).

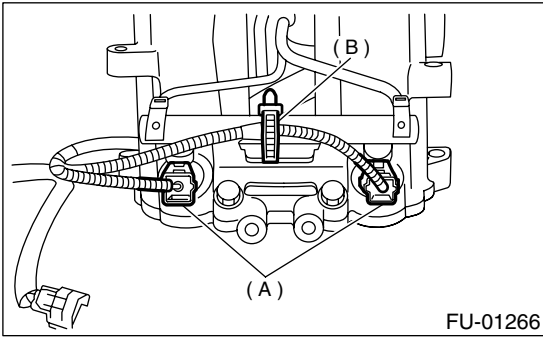

FU-01266

12) Install fuel pipe protector RH.

**Tightening torque:**

**19 N·m (1.9 kgf-m, 13.7 ft-lb)**

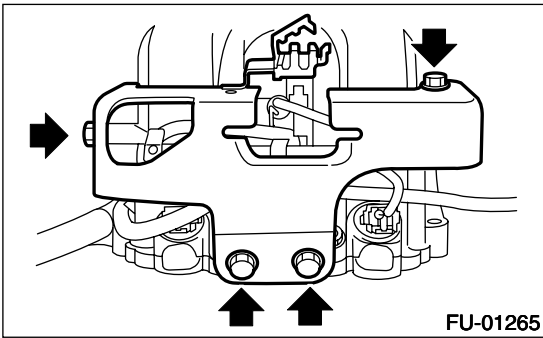

FU-01265

13) Install fuel pipe protector LH.

**Tightening torque:**

**19 N·m (1.9 kgf-m, 13.7 ft-lb)**

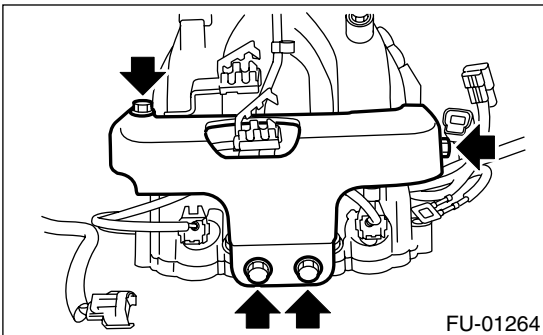

FU-01264

14) Connect pressure regulator vacuum hose to intake manifold.

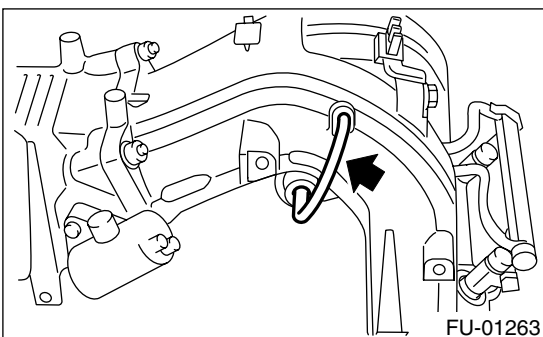

FU-01263

15) Install PCV pipe.

**Tightening torque:**

**5.0 N·m (0.51 kgf-m, 3.7 ft-lb)**

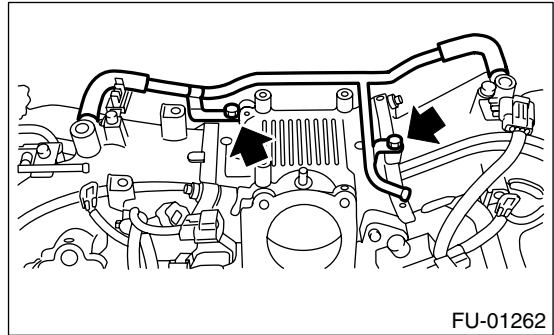

FU-01262

16) Install EGR valve.

<Ref. to FU(H4SO U5)-37, INSTALLATION, EGR Valve.>

17) Install throttle body to intake manifold.

<Ref. to FU(H4SO U5)-14, INSTALLATION, Throttle Body.>

18) Install ignition coil and ignitor assembly. <Ref. to IG(H4SO)-7, INSTALLATION, Ignition Coil and Ignitor Assembly.>

19) Install engine ground terminal to intake manifold.

**Tightening torque:**

**19 N·m (1.9 kgf-m, 13.7 ft-lb)**

- LH side

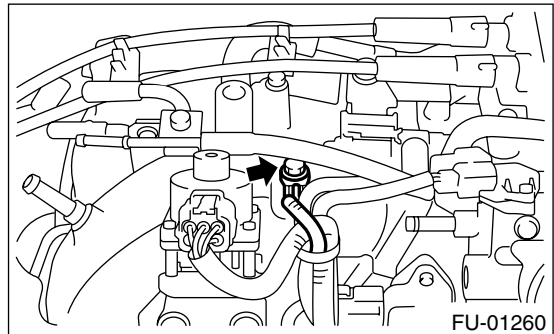

FU-01260

- RH side

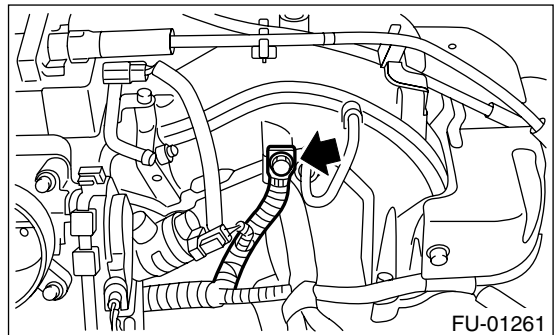

FU-01261

## INTAKE MANIFOLD

FUEL INJECTION (FUEL SYSTEMS)

---

### **E: INSPECTION**

Make sure the fuel pipe and fuel hoses are not cracked and that connections are tight.

## 4. Engine Coolant Temperature Sensor

### A: REMOVAL

- 1) Disconnect battery ground cable.

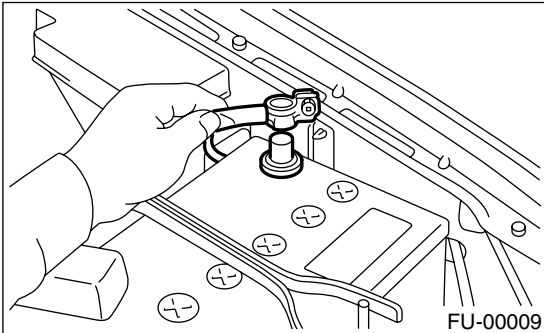

- 2) Remove air intake chamber. <Ref. to IN(H4SO U5)-6, REMOVAL, Air Intake Chamber.>
- 3) Disconnect connector from engine coolant temperature sensor.

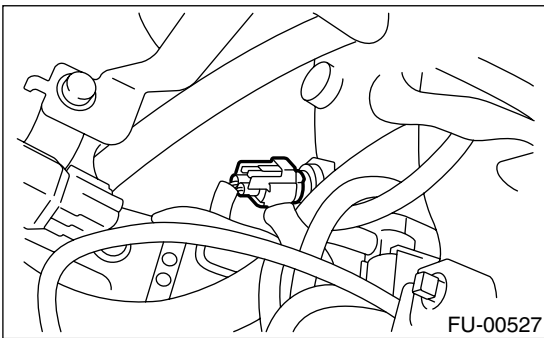

- 4) Remove engine coolant temperature sensor.

### B: INSTALLATION

Install in the reverse order of removal.

#### **Tightening torque:**

**18 N·m (1.8 kgf-m, 1.3 ft-lb)**

# CRANKSHAFT POSITION SENSOR

FUEL INJECTION (FUEL SYSTEMS)

## 5. Crankshaft Position Sensor

### A: REMOVAL

1) Disconnect battery ground cable.

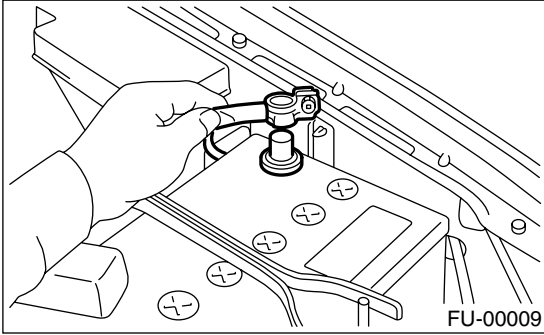

2) Remove bolt which installs crankshaft position sensor to cylinder block.

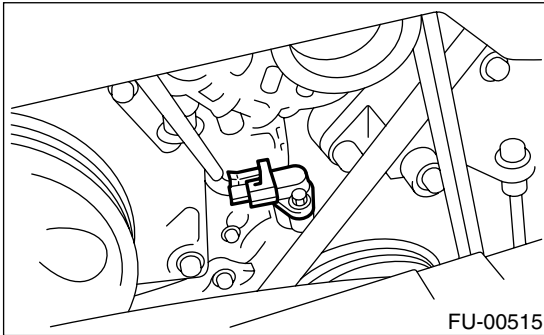

3) Remove crankshaft position sensor, and disconnect connector from it.

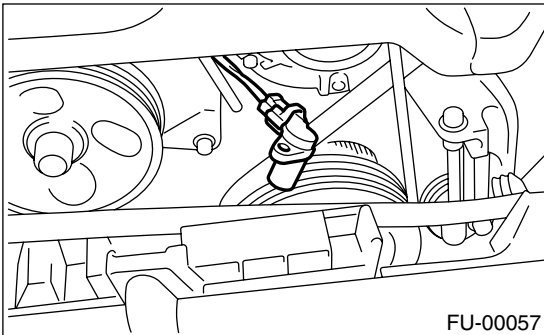

### B: INSTALLATION

Install in the reverse order of removal.

**Tightening torque:**

**T: 6.4 N·m (0.65 kgf-m, 4.7 ft-lb)**

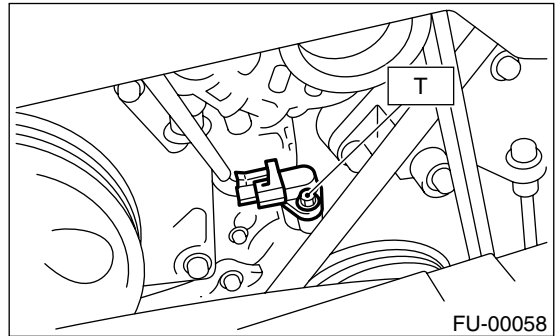

# CAMSHAFT POSITION SENSOR

FUEL INJECTION (FUEL SYSTEMS)

## 6. Camshaft Position Sensor

### A: REMOVAL

1) Disconnect battery ground cable.

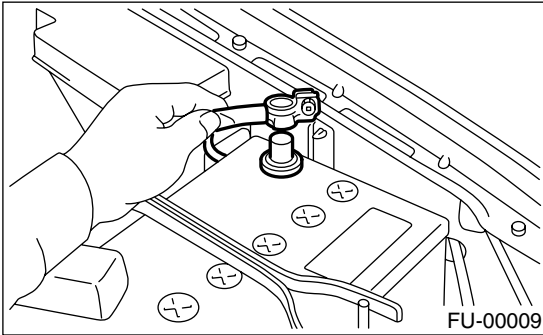

2) Disconnect connector from camshaft position sensor.

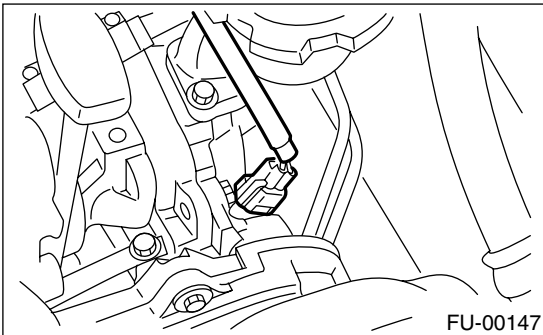

3) Remove bolt which installs camshaft position sensor to camshaft position sensor support.

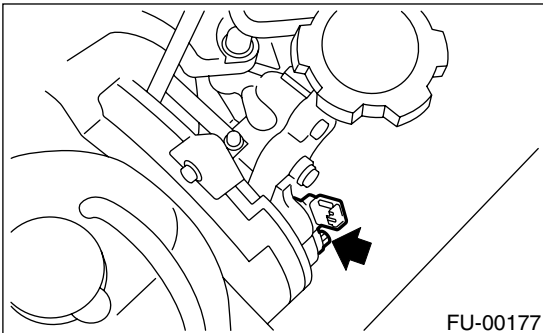

4) Remove bolt which installs camshaft position sensor support to camshaft cap LH.

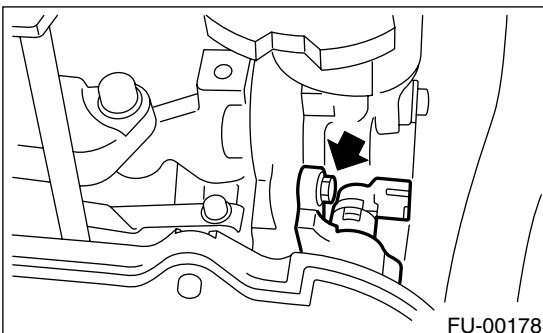

5) Remove camshaft position sensor and camshaft position sensor support as a unit.

6) Remove camshaft position sensor itself.

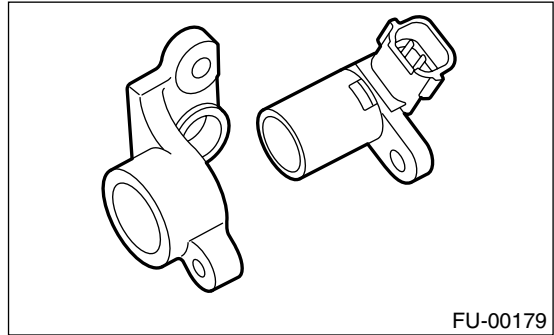

### B: INSTALLATION

Install in the reverse order of removal.

#### *Tightening torque:*

- **Camshaft position sensor support;**  
**6.4 N·m (0.65 kgf-m, 4.7 ft-lb)**
- **Camshaft position sensor;**  
**6.4 N·m (0.65 kgf-m, 4.7 ft-lb)**

# KNOCK SENSOR

FUEL INJECTION (FUEL SYSTEMS)

## 7. Knock Sensor

### A: REMOVAL

- 1) Disconnect battery ground cable.

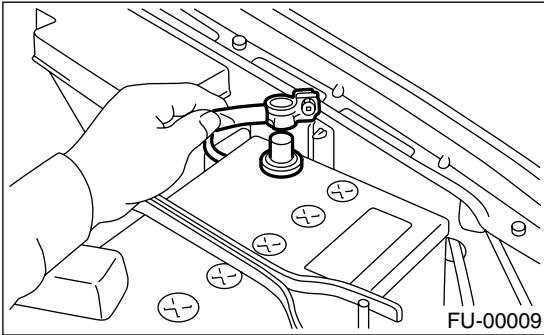

- 2) Remove air intake chamber.  
<Ref. to IN(H4SO U5)-6, REMOVAL, Air Intake Chamber.>
- 3) Disconnect knock sensor connector.

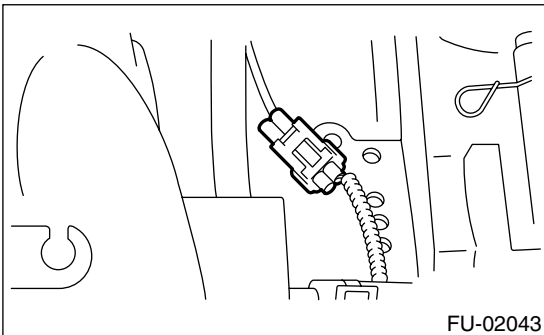

- 4) Remove knock sensor from cylinder block.

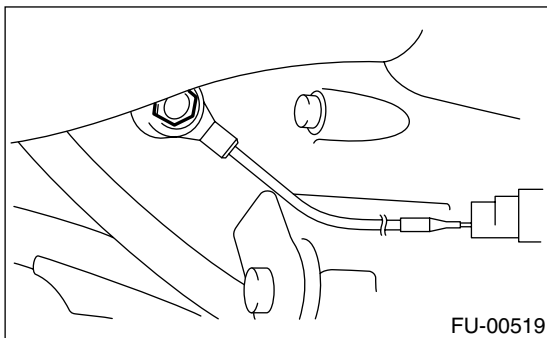

### B: INSTALLATION

- 1) Install knock sensor to cylinder block.

**Tightening torque:**

**24 N·m (2.4 kgf-m, 17.4 ft-lb)**

NOTE:

The extraction area of the knock sensor cord must be positioned at a 60° angle relative to the engine rear.

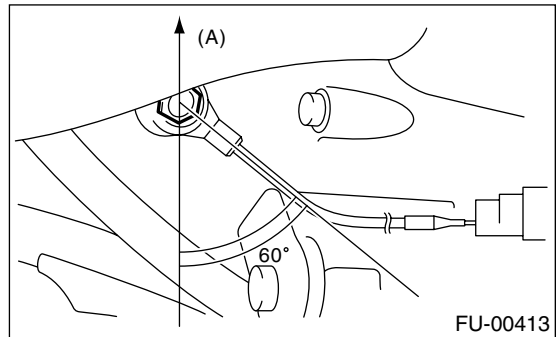

(A) Front side

- 2) Connect knock sensor connector.

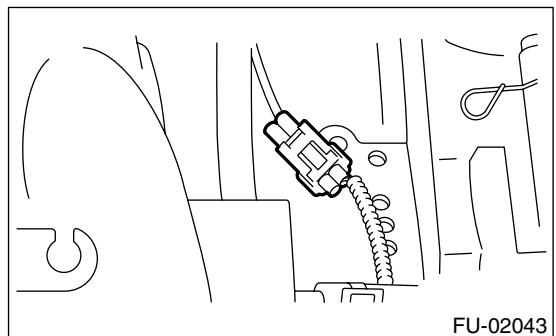

- 3) Install air intake chamber.  
<Ref. to IN(H4SO U5)-6, INSTALLATION, Air Intake Chamber.>
- 4) Connect battery ground cable.

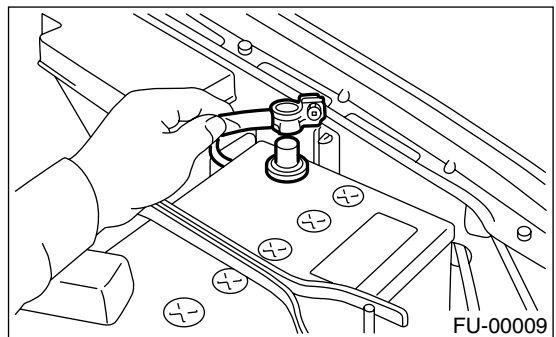

## 8. Throttle Position Sensor

### A: SPECIFICATIONS

Do not remove throttle sensor from throttle body because throttle body should not be disassembled. For removal and installation, refer to "Throttle Body". <Ref. to FU(H4SO U5)-14, REMOVAL, Throttle Body.> and <Ref. to FU(H4SO U5)-14, INSTALLATION, Throttle Body.>

# PRESSURE SENSOR

FUEL INJECTION (FUEL SYSTEMS)

---

## 9. Pressure Sensor

### A: REMOVAL

- 1) Disconnect battery ground cable.

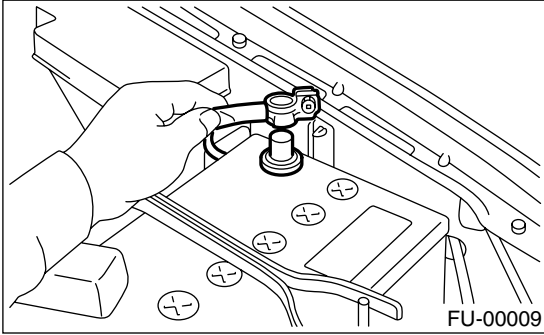

- 2) Disconnect connector from pressure sensor.

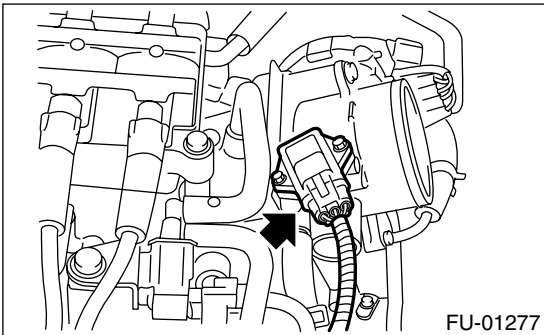

- 3) Remove pressure sensor from throttle body.

### B: INSTALLATION

Install in the reverse order of removal.

NOTE:

Replace O-ring with a new one.

**Tightening torque:**

**1.6 N·m (0.16 kgf-m, 1.2 ft-lb)**



## 10. Air Flow and Intake Air Temperature Sensor

### A: REMOVAL

- 1) Disconnect the ground cable from battery.

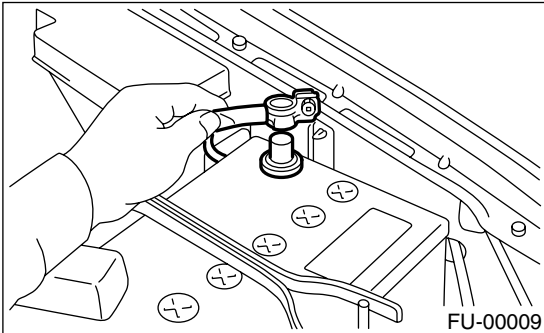

- 2) Disconnect the connector from the air flow and intake air temperature sensor.

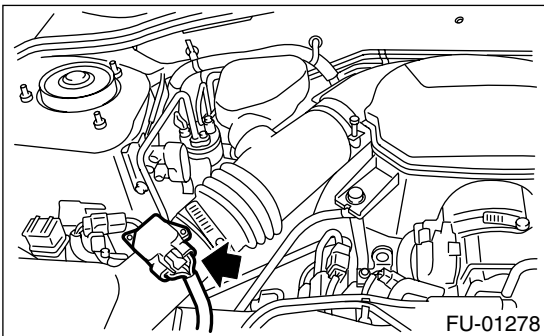

- 3) Remove the air flow and intake air temperature sensor from air cleaner case.

### B: INSTALLATION

Install in the reverse order of removal.

#### **Tightening torque:**

**1.0 N·m (0.10 kgf·m, 0.7 ft·lb)**

# TUMBLE GENERATOR VALVE ASSEMBLY

FUEL INJECTION (FUEL SYSTEMS)

---

## 11. Tumble Generator Valve Assembly

### A: SPECIFICATIONS

For removal and installation, refer to "Intake Manifold". <Ref. to FU(H4SO U5)-15, REMOVAL, Intake Manifold.> and <Ref. to FU(H4SO U5)-17, INSTALLATION, Intake Manifold.>

## 12. Tumble Generator Valve Actuator

### A: REMOVAL

- 1) Release the fuel pressure. <Ref. to FU(H4SO U5)-53, RELEASING OF FUEL PRESSURE, OPERATION, Fuel.>
- 2) Open the fuel filler lid and remove the fuel filler cap.
- 3) Disconnect the ground cable from battery.

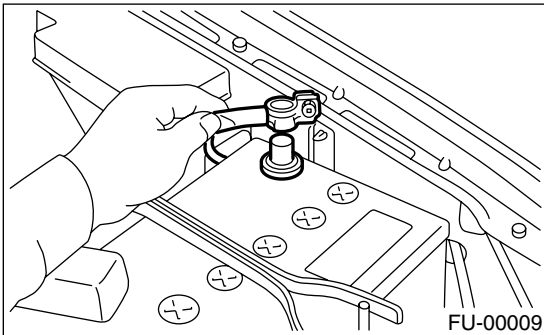

- 4) Remove the throttle body. <Ref. to FU(H4SO U5)-14, REMOVAL, Throttle Body.>
- 5) Disconnect the connector from tumble generator valve actuator.
- 6) Remove the tumble generator valve actuator.

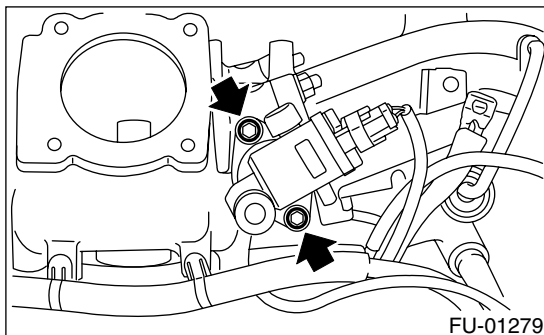

### B: INSTALLATION

Install in the reverse order of removal.

#### **Tightening torque:**

**5.9 N·m (0.60 kgf·m, 4.3 ft·lb)**

# TUMBLE GENERATOR VALVE POSITION SENSOR

FUEL INJECTION (FUEL SYSTEMS)

---

## 13. Tumble Generator Valve Position Sensor

### A: SPECIFICATIONS

Do not remove tumble generator valve position sensor from tumble generator valve assembly because the sensor cannot be adjusted when installing. For removal and installation, refer to "Tumble Generator Valve Assembly". <Ref. to FU(H4SO U5)-34, SPECIFICATIONS, Tumble Generator Valve Assembly.>

## 14.EGR Valve

### A: REMOVAL

- 1) Disconnect battery ground cable.

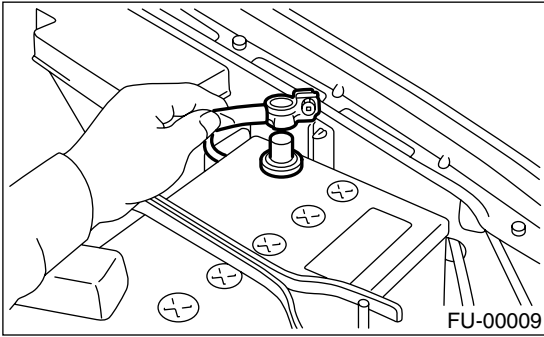

- 2) Disconnect connector from EGR valve.

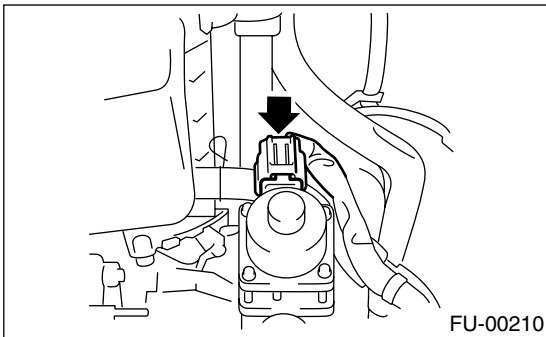

- 3) Remove EGR valve from intake manifold.

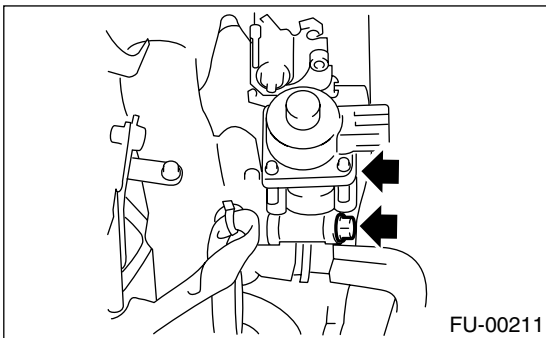

### B: INSTALLATION

Install in the reverse order of removal.

NOTE:

Always use a new gasket.

**Tightening torque:**

**19 N·m (1.9 kgf-m, 14.0 ft-lb)**

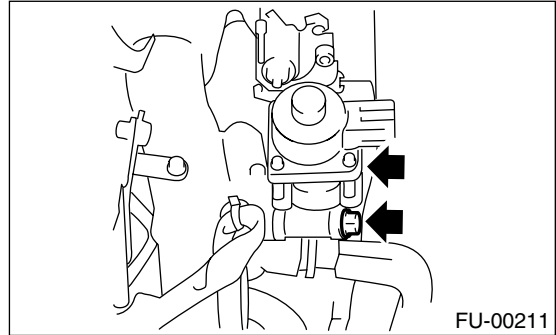

# FUEL INJECTOR

FUEL INJECTION (FUEL SYSTEMS)

## 15. Fuel Injector

### A: REMOVAL

#### 1. RH SIDE

- 1) Release fuel pressure.  
<Ref. to FU(H4SO U5)-53, RELEASING OF FUEL PRESSURE, OPERATION, Fuel.>
- 2) Open fuel flap lid, and remove fuel filler cap.
- 3) Disconnect battery ground cable.

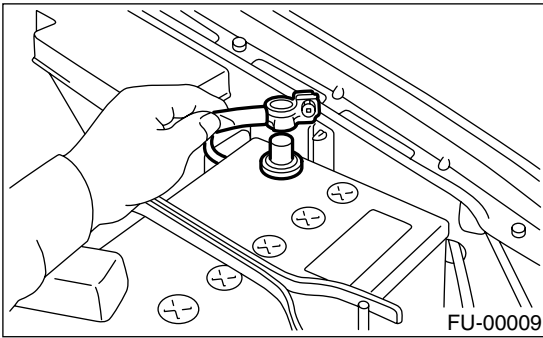

- 4) Remove air cleaner case.  
<Ref. to IN(H4SO U5)-5, REMOVAL, Air Cleaner Case.>
- 5) Remove spark plug cords from spark plugs (#1 and #3 cylinders).

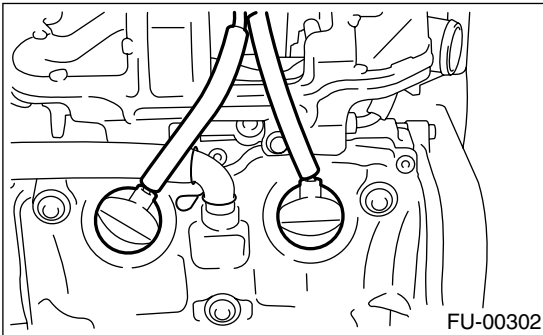

- 6) Remove power steering pump and tank from brackets.

- (1) Remove front V-belt.  
<Ref. to ME(H4SO)-43, REMOVAL, V-belt.>
- (2) Remove bolts which hold power steering pipes onto intake manifold protector.

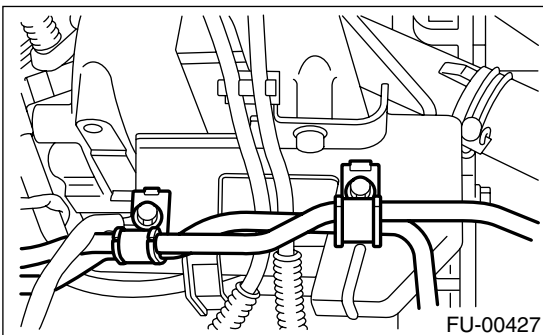

- (3) Remove bolts which install power steering pump to bracket.

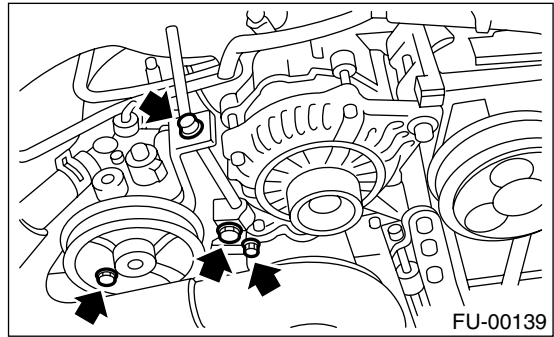

- (4) Disconnect connector from power steering pump switch.

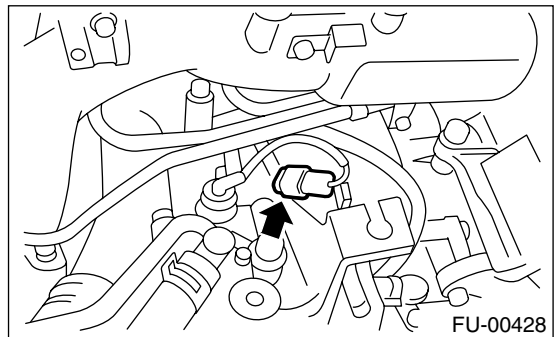

- (5) Remove power steering tank from the bracket by pulling it upwards.

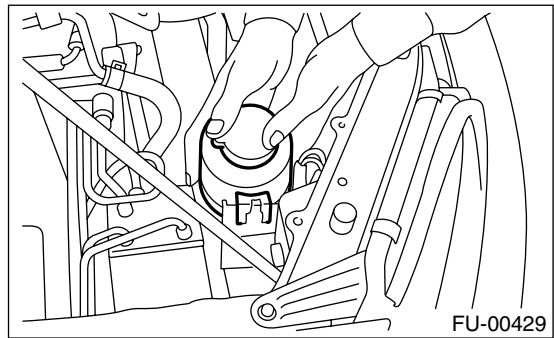

- (6) Place power steering pump and tank on the right side wheel apron.

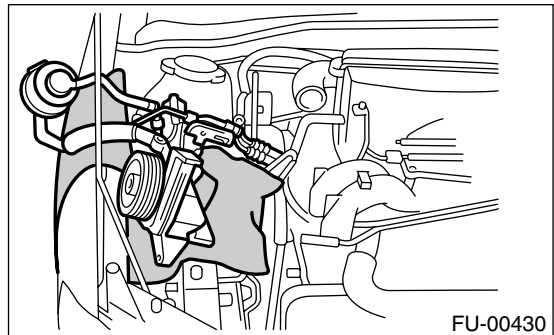

7) Remove fuel pipe protector RH.

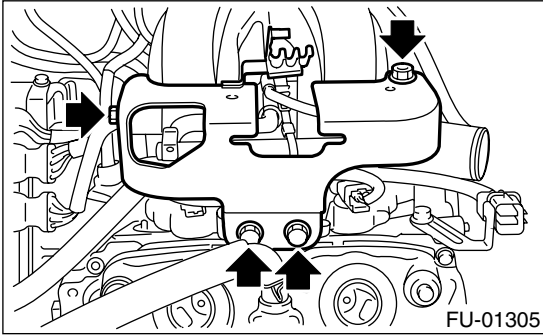

8) Disconnect connector (A) from fuel injector.  
9) Remove harness band (B) which holds engine harness onto injector pipe.

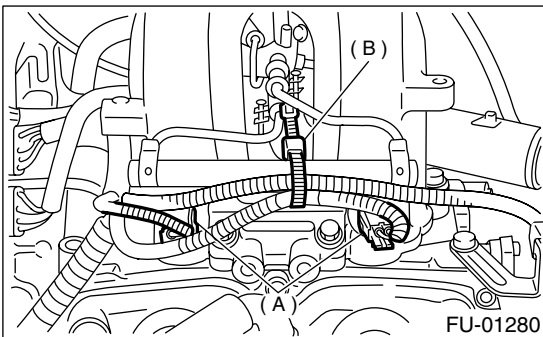

10) Remove bolts which hold injector pipe to intake manifold.

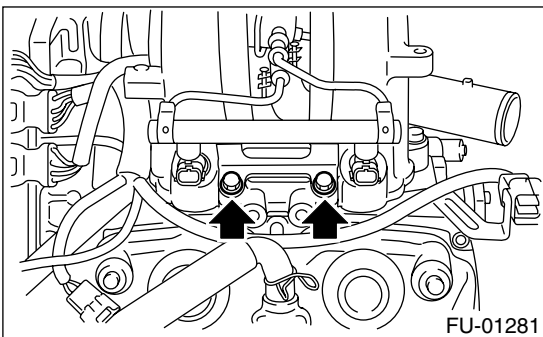

11) Lift up fuel injector pipe, and remove fuel injector.

## 2. LH SIDE

1) Release fuel pressure. <Ref. to FU(H4SO U5)-53, RELEASING OF FUEL PRESSURE, OPERATION, Fuel.>  
2) Open fuel flap lid, and remove fuel filler cap.  
3) Disconnect battery ground cable.

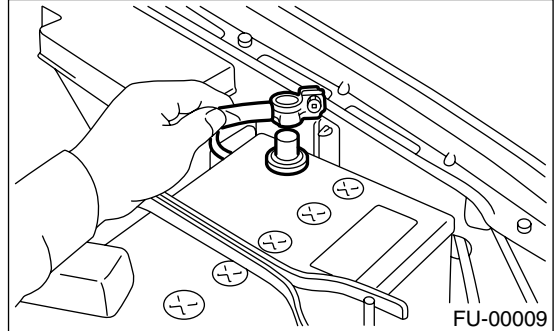

4) Remove two bolts which install washer tank on body.

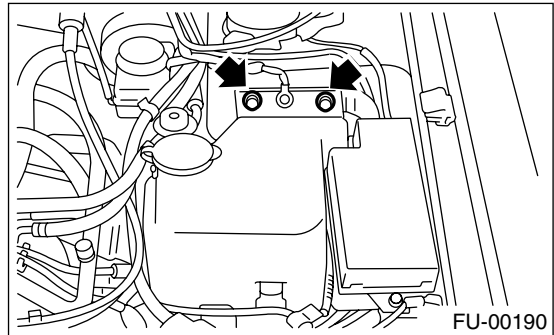

5) Disconnect connector from front window washer motor.  
6) Disconnect connector from rear gate glass washer motor.

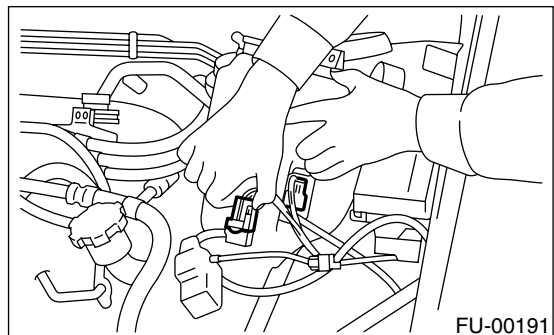

7) Disconnect rear window glass washer hose from washer motor, then plug connection with a suitable cap.

# FUEL INJECTOR

## FUEL INJECTION (FUEL SYSTEMS)

8) Move washer tank, and secure it away from working area.

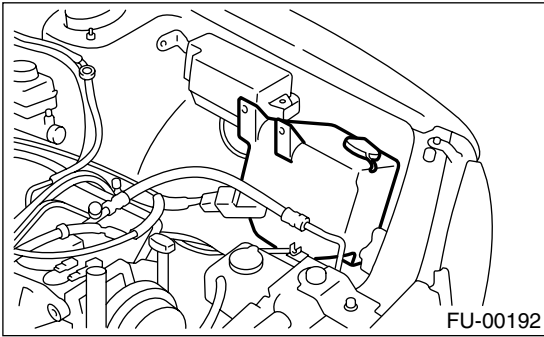

9) Remove spark plug cords from spark plugs (#2 and #4 cylinders).

10) Remove fuel pipe protector LH.

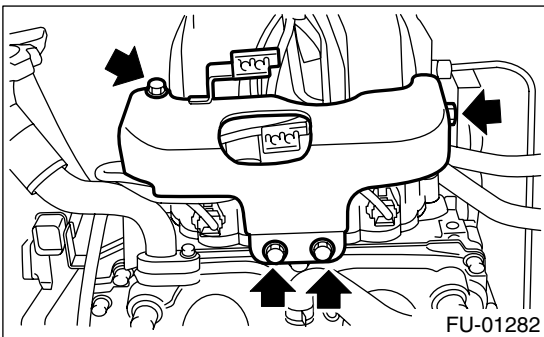

11) Disconnect connector (A) from fuel injector.

12) Remove harness band (B) which holds engine harness onto injector pipe.

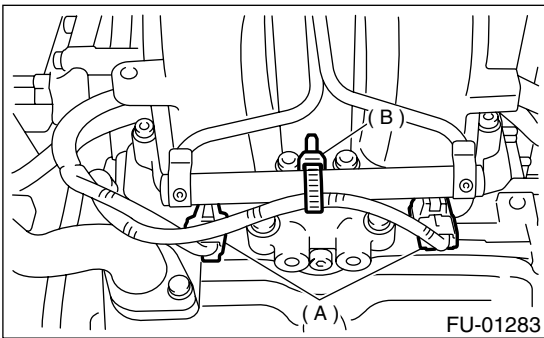

13) Remove bolt which holds injector pipe to intake manifold.

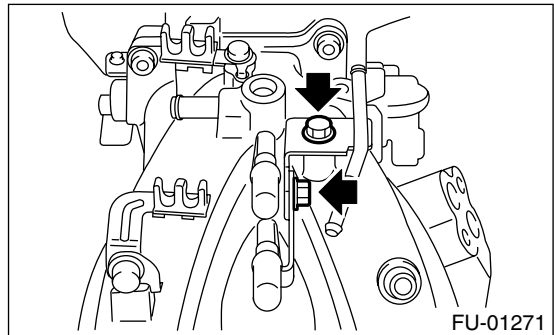
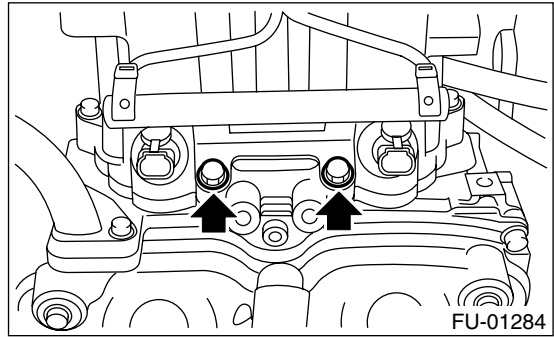

14) Lift up fuel injector pipe, and remove fuel injector.

## B: INSTALLATION

### 1. RH SIDE

Install in the reverse order of removal.

NOTE:

Replace O-rings with new ones.

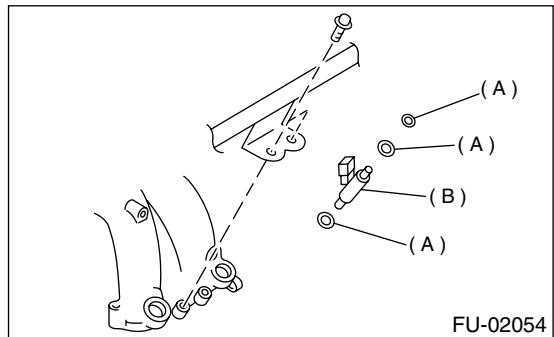

- (A) O-ring
- (B) Fuel injector



# FUEL INJECTOR

FUEL INJECTION (FUEL SYSTEMS)

**Tightening torque:**  
**19 N·m (0.19 kgf-m, 1.4 ft-lb)**

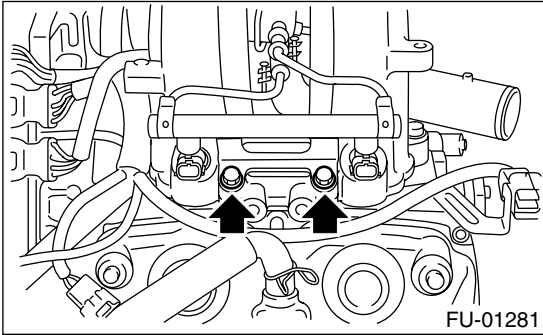

**Tightening torque:**  
**5.0 N·m (0.51 kgf-m, 3.7 ft-lb)**

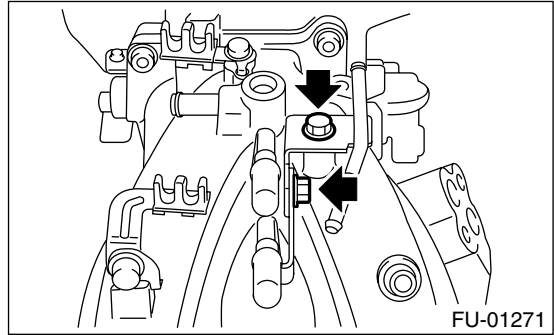

**Tightening torque:**  
**19 N·m (0.19 kgf-m, 1.4 ft-lb)**

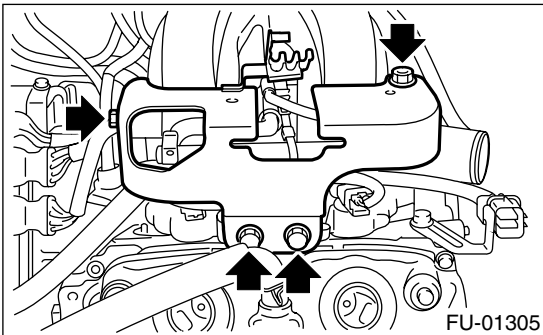

**Tightening torque:**  
**19 N·m (1.9 kgf-m, 13.7 ft-lb)**

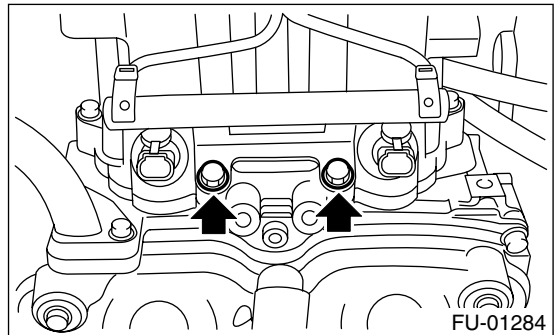

## 2. LH SIDE

Install in the reverse order of removal.

**NOTE:**

Replace O-rings with new ones.

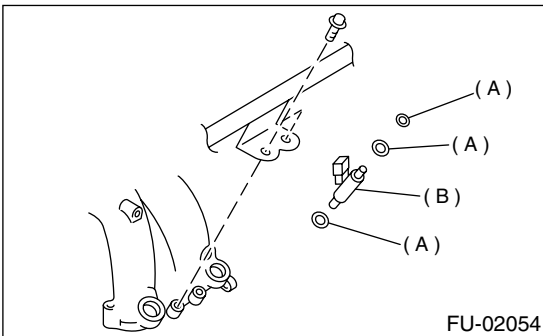

- (A) O-ring
- (B) Fuel injector

**Tightening torque:**  
**19 N·m (1.9 kgf-m, 13.7 ft-lb)**

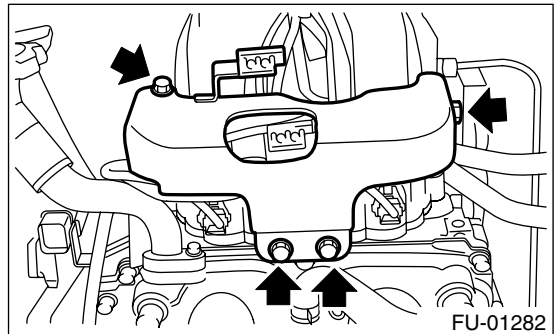

# FRONT OXYGEN (A/F) SENSOR

FUEL INJECTION (FUEL SYSTEMS)

## 16. Front Oxygen (A/F) Sensor

### A: REMOVAL

#### 1. LH SIDE

- 1) Disconnect battery ground cable.

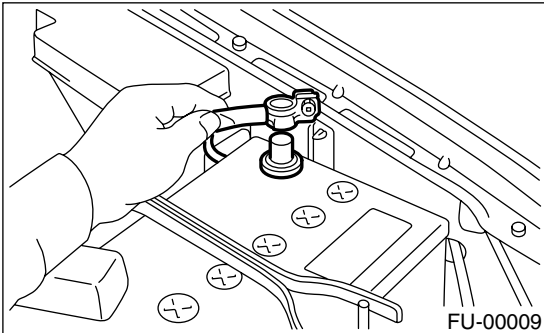

- 2) Disconnect connectors from bracket and front oxygen (A/F) sensor.

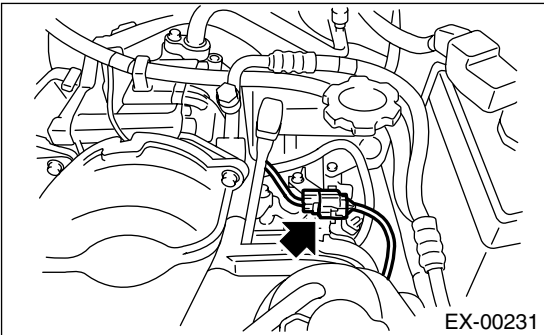

- 3) Lift-up the vehicle.
- 4) Remove undercover.
- 5) Remove front oxygen (A/F) sensor harness from bracket.

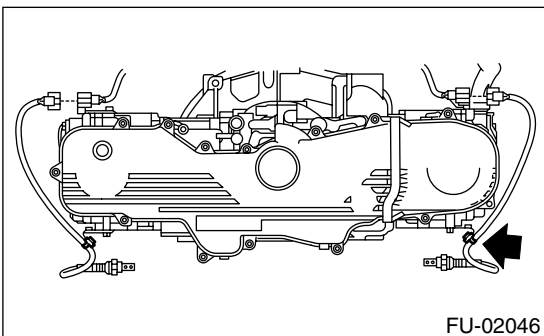

- 6) Apply SUBARU CRC or its equivalent to thread-  
ed portion of front oxygen (A/F) sensor, and leave it  
for one minute or more.

**SUBARU CRC (Part No. 004301003)**

- 7) Remove front oxygen (A/F) sensor.

#### CAUTION:

When removing the oxygen (A/F) sensor, wait until exhaust pipe cools, otherwise it will damage exhaust pipe.

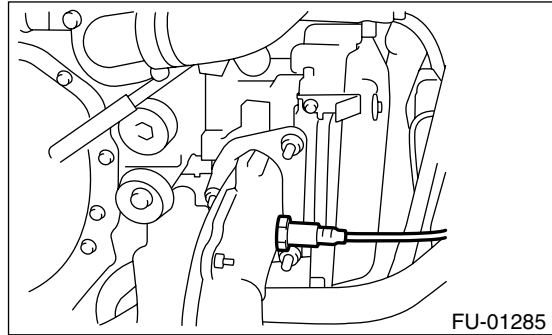

#### 2. RH SIDE

- 1) Disconnect battery ground cable.

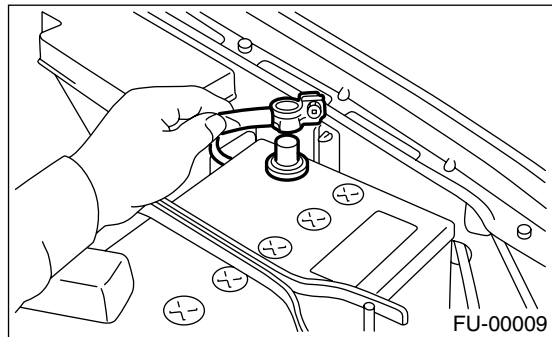

- 2) Disconnect connectors from bracket and front oxygen (A/F) sensor.

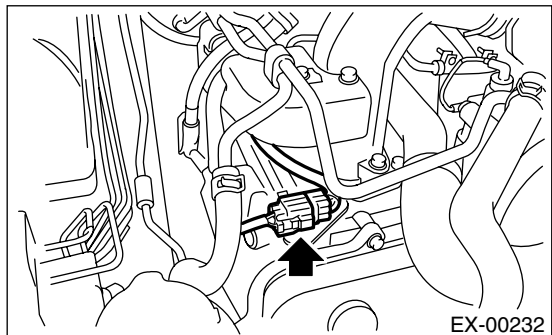

- 3) Lift-up the vehicle.
- 4) Remove undercover.

# FRONT OXYGEN (A/F) SENSOR

FUEL INJECTION (FUEL SYSTEMS)

- 5) Remove front oxygen (A/F) sensor harness from bracket.

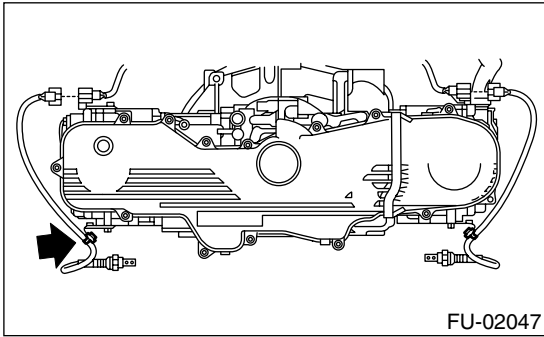

- 6) Apply SUBARU CRC or its equivalent to threaded portion of front oxygen (A/F) sensor, and leave it for one minute or more.

**SUBARU CRC (Part No. 004301003)**

- 7) Remove front oxygen (A/F) sensor.

**CAUTION:**

When removing the oxygen (A/F) sensor, wait until exhaust pipe cools, otherwise it will damage exhaust pipe.

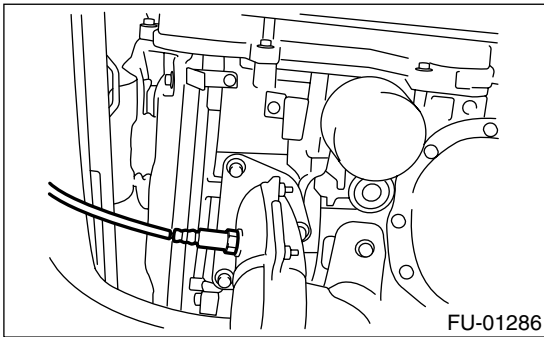

## B: INSTALLATION

### 1. LH SIDE

- 1) Before installing front oxygen (A/F) sensor, apply anti-seize compound only to threaded portion of front oxygen (A/F) sensor to make the next removal easier.

**Anti-seize compound:**  
**SS-30 by JET LUBE**

**CAUTION:**

Never apply anti-seize compound to protector of front oxygen (A/F) sensor.

- 2) Install front oxygen (A/F) sensor.

**Tightening torque:**

**21 N·m (2.1 kgf-m, 15.2 ft-lb)**

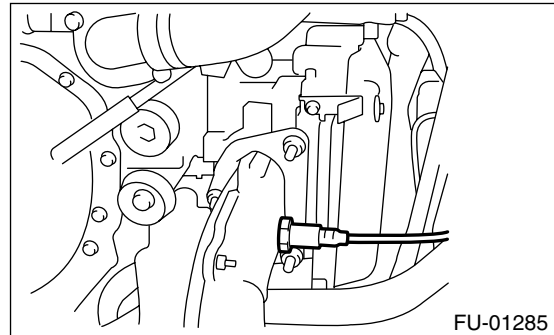

- 3) Install front oxygen (A/F) sensor harness to bracket.

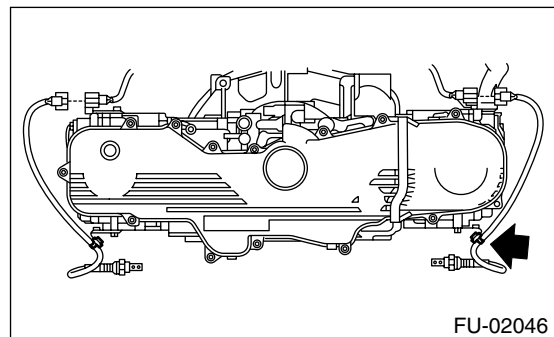

- 4) Install undercover.  
5) Lower the vehicle.  
6) Connect connector of front oxygen (A/F) sensor, and install connector to bracket.

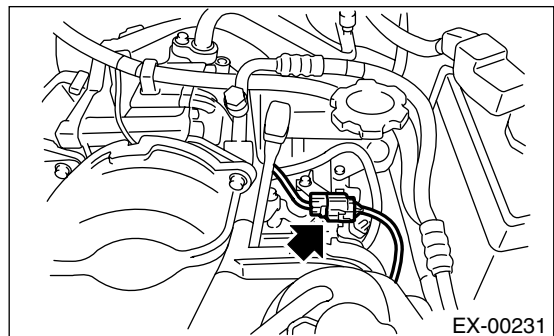

- 7) Connect battery ground cable.

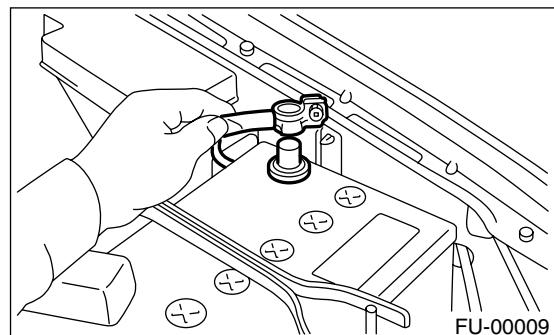

# FRONT OXYGEN (A/F) SENSOR

FUEL INJECTION (FUEL SYSTEMS)

## 2. RH SIDE

1) Before installing front oxygen (A/F) sensor, apply anti-seize compound only to threaded portion of front oxygen (A/F) sensor to make the next removal easier.

**Anti-seize compound:**  
**SS-30 by JET LUBE**

**CAUTION:**  
Never apply anti-seize compound to protector of front oxygen (A/F) sensor.

2) Install front oxygen (A/F) sensor.

**Tightening torque:**  
**21 N·m (2.1 kgf-m, 15.2 ft-lb)**

7) Connect battery ground cable.

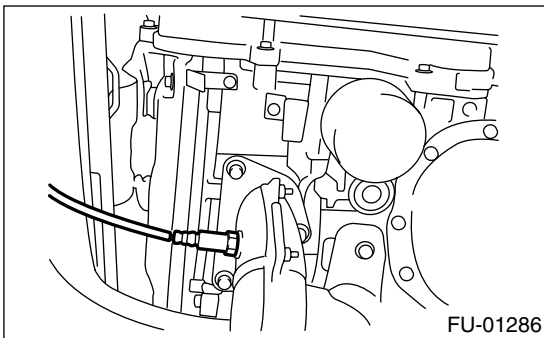
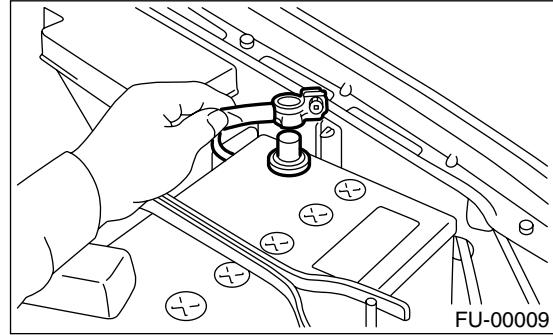

3) Install front oxygen (A/F) sensor harness to bracket.

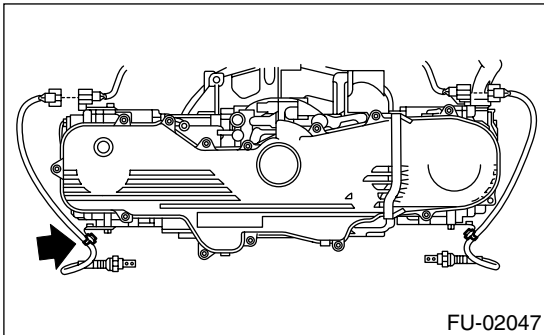

4) Install undercover.

5) Lower the vehicle.

6) Connect connector of front oxygen (A/F) sensor.

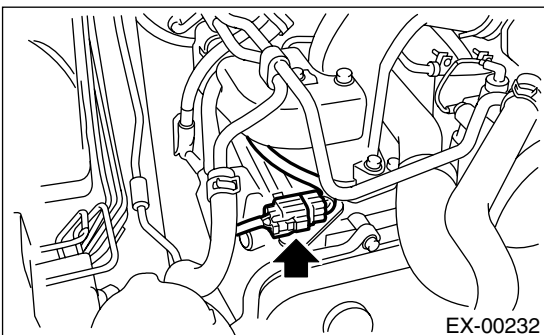

# FRONT OXYGEN SENSOR

FUEL INJECTION (FUEL SYSTEMS)

## 17. Front Oxygen Sensor

### A: REMOVAL

#### 1. LH SIDE

- 1) Disconnect battery ground cable.

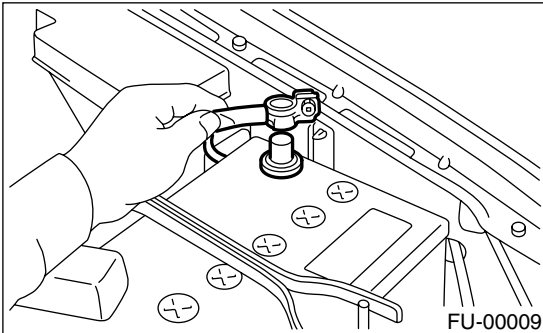

- 2) Disconnect connector from front oxygen sensor.

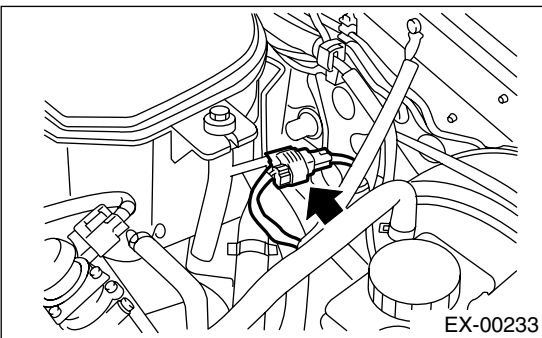

- 3) Lift-up the vehicle.
- 4) Remove front oxygen sensor harness from bracket.

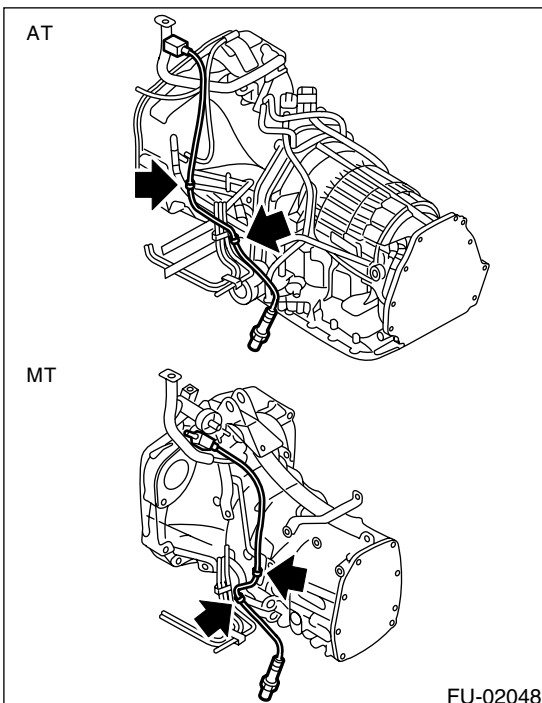

- 5) Apply SUBARU CRC or its equivalent to threaded portion of front oxygen sensor, and leave it for one minute or more.

**SUBARU CRC (Part No. 004301003)**

- 6) Remove front oxygen sensor.

#### CAUTION:

**When removing the oxygen sensor, wait until exhaust pipe cools, otherwise it will damage exhaust pipe.**

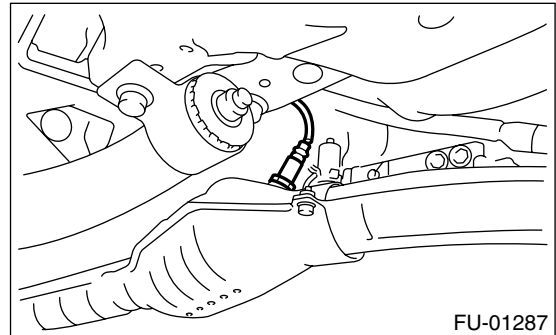

#### 2. RH SIDE

- 1) Disconnect battery ground cable.

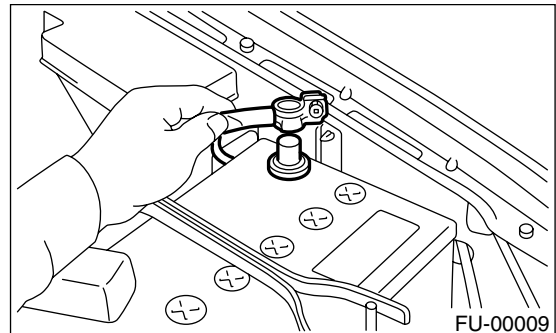

- 2) Disconnect connector from front oxygen sensor.

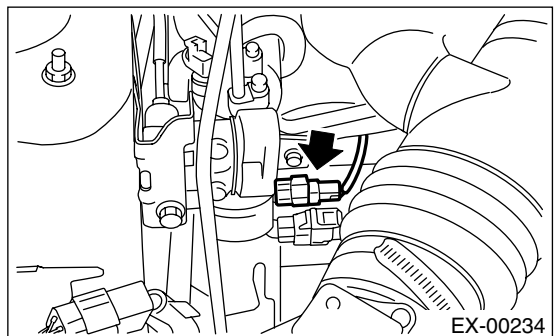

- 3) Lift-up the vehicle.

# FRONT OXYGEN SENSOR

## FUEL INJECTION (FUEL SYSTEMS)

4) Remove front oxygen sensor harness from bracket.

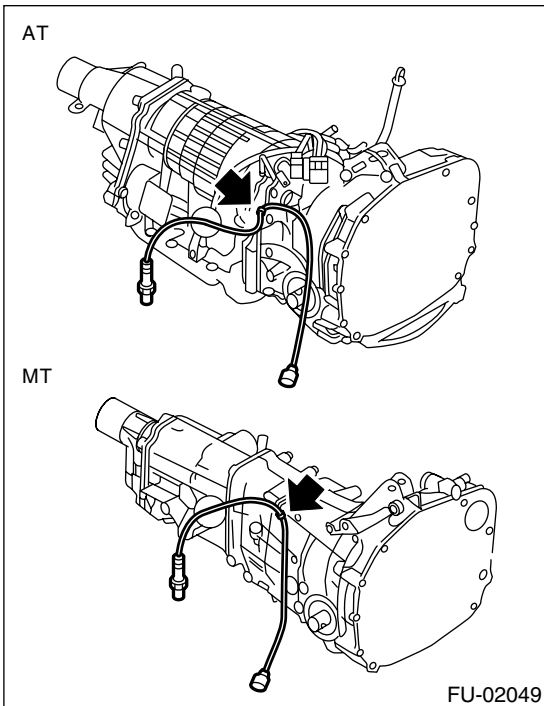

5) Apply SUBARU CRC or its equivalent to threaded portion of front oxygen sensor, and leave it for one minute or more.

**SUBARU CRC (Part No. 004301003)**

6) Remove front oxygen sensor.

### CAUTION:

When removing the oxygen sensor, wait until exhaust pipe cools, otherwise it will damage exhaust pipe.

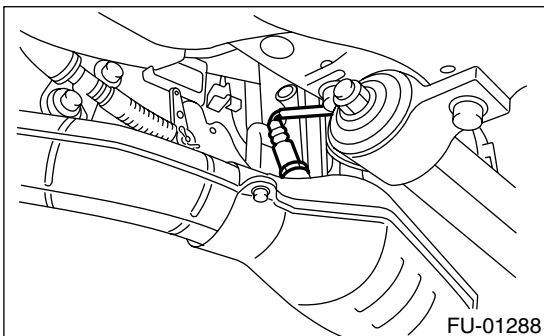

## B: INSTALLATION

### 1. LH SIDE

1) Before installing front oxygen sensor, apply anti-seize compound only to threaded portion of front oxygen sensor to make the next removal easier.

### CAUTION:

Never apply anti-seize compound to protector of rear oxygen sensor.

**Anti-seize compound:**

**SS-30 by JET LUBE**

2) Install front oxygen sensor.

**Tightening torque:**

**21 N·m (2.1 kgf-m, 15.2 ft-lb)**

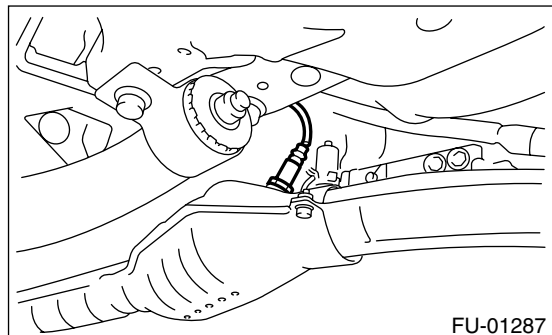

3) Install front oxygen sensor harness to bracket.

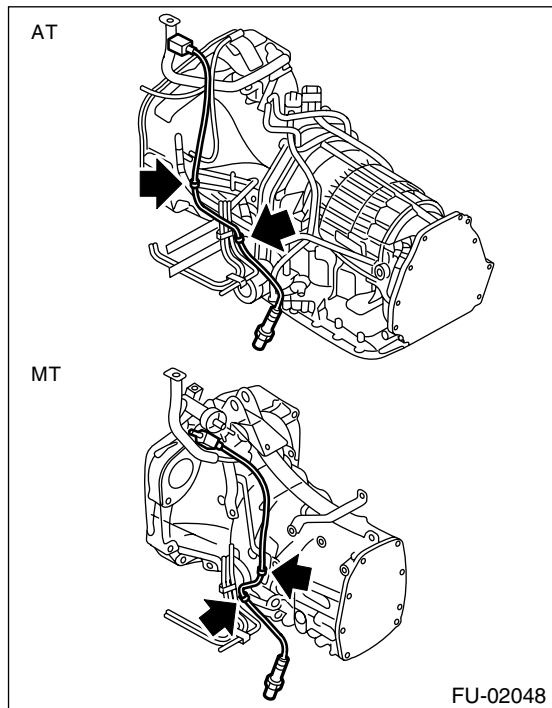

4) Lower the vehicle.

# FRONT OXYGEN SENSOR

FUEL INJECTION (FUEL SYSTEMS)

5) Connect connector to front oxygen sensor.

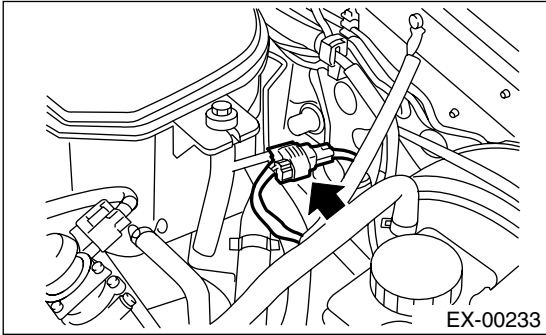

6) Connect battery ground cable.

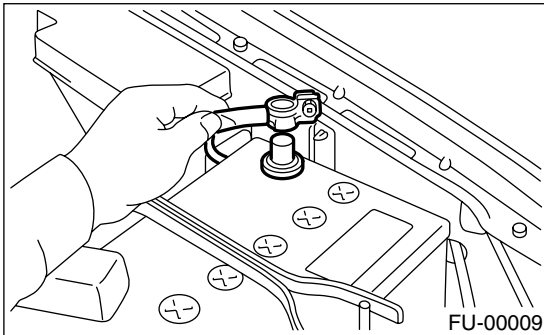

## 2. RH SIDE

1) Before installing front oxygen sensor, apply anti-seize compound only to threaded portion of front oxygen sensor to make the next removal easier.

### CAUTION:

Never apply anti-seize compound to protector of front oxygen sensor.

**Anti-seize compound:**  
**SS-30 by JET LUBE**

2) Install front oxygen sensor.

### Tightening torque:

**21 N·m (2.1 kgf·m, 15.2 ft·lb)**

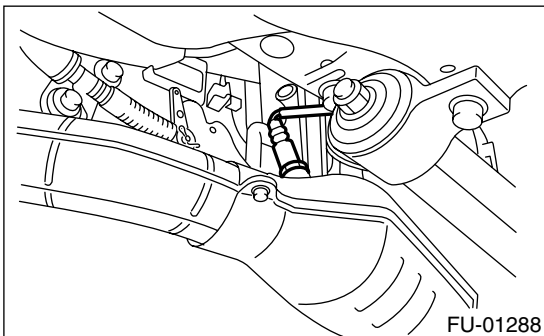

3) Install front oxygen sensor harness to bracket.

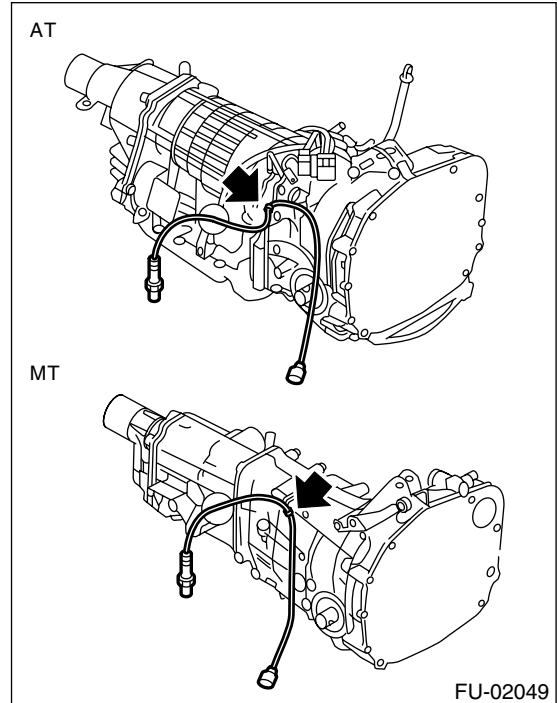

4) Lower the vehicle.

5) Connect connector to front oxygen sensor.

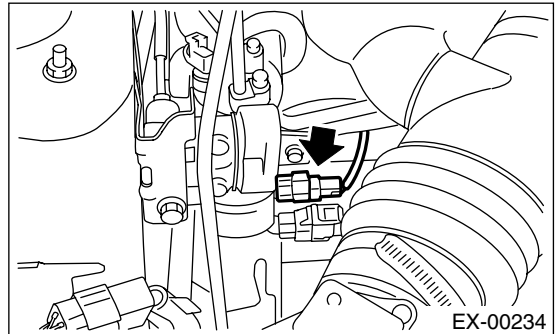

6) Connect battery ground cable.

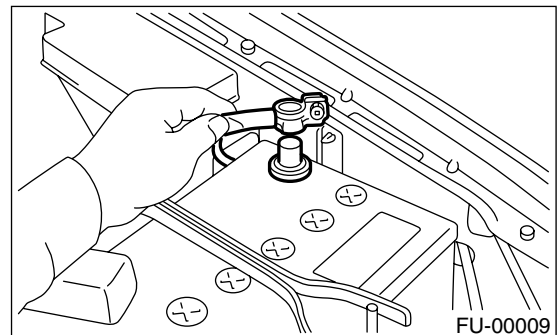

# REAR OXYGEN SENSOR

FUEL INJECTION (FUEL SYSTEMS)

## 18. Rear Oxygen Sensor

### A: REMOVAL

- 1) Disconnect battery ground cable.

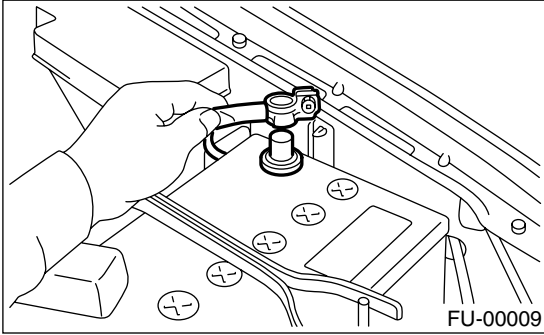

- 2) Lift-up the vehicle.
- 3) Disconnect connector from rear oxygen sensor.

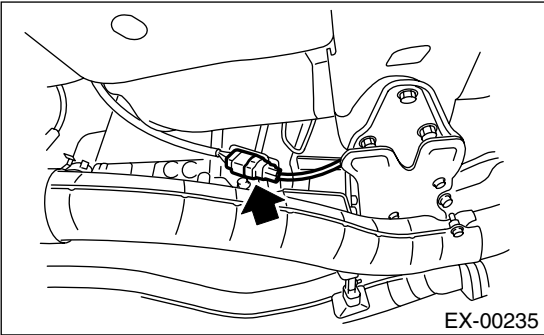

- 4) Apply SUBARU CRC or its equivalent to threaded portion of rear oxygen sensor, and leave it for one minute or more.

**SUBARU CRC (Part No. 004301003)**

- 5) Remove rear oxygen sensor.

### CAUTION:

**When removing the oxygen sensor, wait until exhaust pipe cools, otherwise it will damage exhaust pipe.**

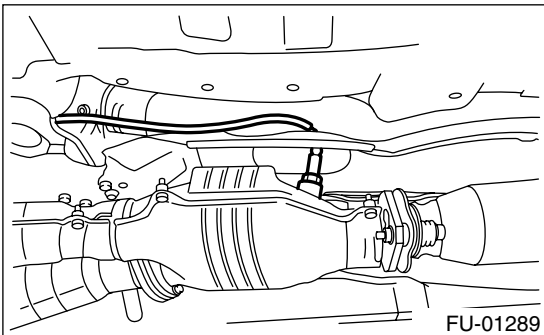

### B: INSTALLATION

- 1) Before installing rear oxygen sensor, apply anti-seize compound only to threaded portion of rear oxygen sensor to make the next removal easier.

### CAUTION:

**Never apply anti-seize compound to protector of rear oxygen sensor.**

### Anti-seize compound:

**SS-30 by JET LUBE**

- 2) Install rear oxygen sensor.

### Tightening torque:

**21 N·m (2.1 kgf-m, 15.2 ft-lb)**

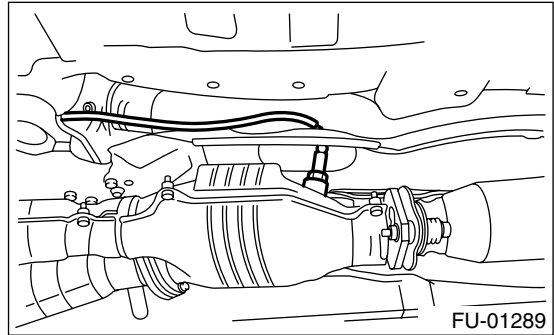

- 3) Connect connector to rear oxygen sensor.

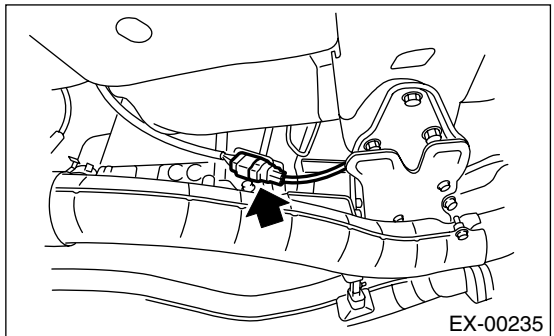

- 4) Lower the vehicle.
- 5) Connect battery ground cable.

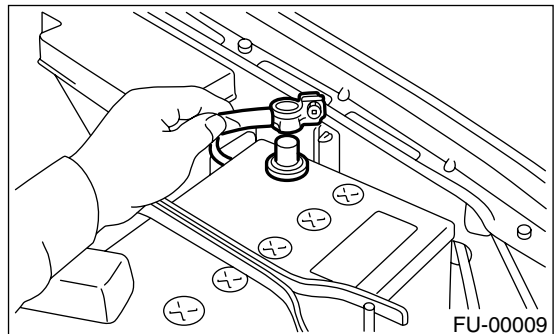



## 19.Engine Control Module

### A: REMOVAL

- 1) Disconnect battery ground cable.

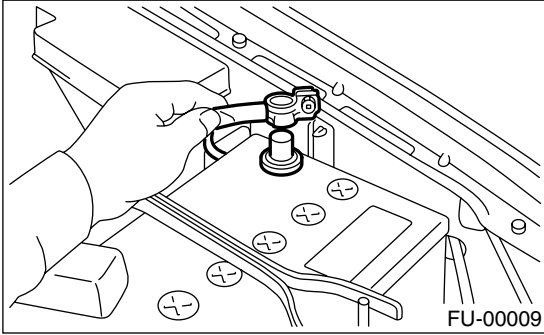

- 2) Remove lower inner trim of passenger side.  
<Ref. to EI-51, REMOVAL, Lower Inner Trim.>
- 3) Detach floor mat of passenger seat.
- 4) Remove protect cover.

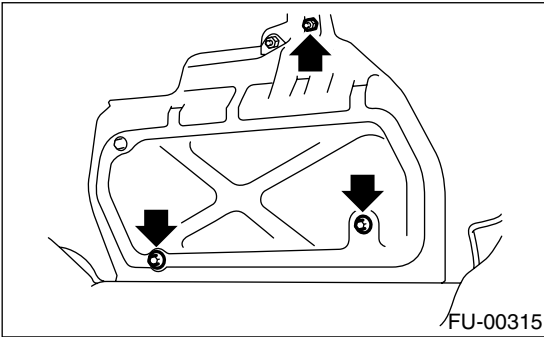

- 5) Remove nuts (A) which hold ECM to bracket.
- 6) Remove clip (B) from bracket.

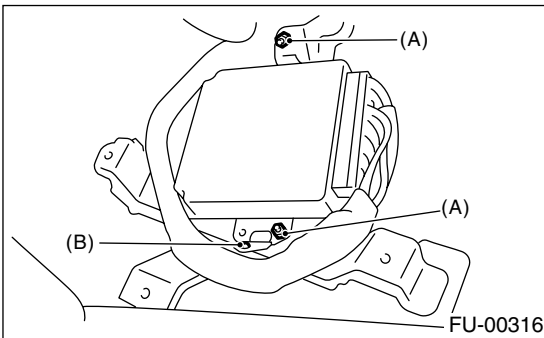

- 7) Disconnect ECM connectors and take out ECM.

### B: INSTALLATION

Install in the reverse order of removal.

#### CAUTION:

When replacing ECM, be careful not to use the wrong spec. ECM to avoid any damage to the fuel injection system.

*Tightening torque:*

**5 N·m (0.51 kgf-m, 3.7 ft-lb)**

# MAIN RELAY

FUEL INJECTION (FUEL SYSTEMS)

---

## 20.Main Relay

### A: REMOVAL

- 1) Disconnect battery ground cable.

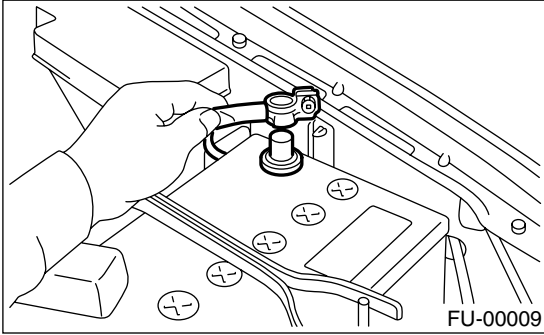

- 2) Remove lower cover of driver side.
- 3) Disconnect connectors from main relay.

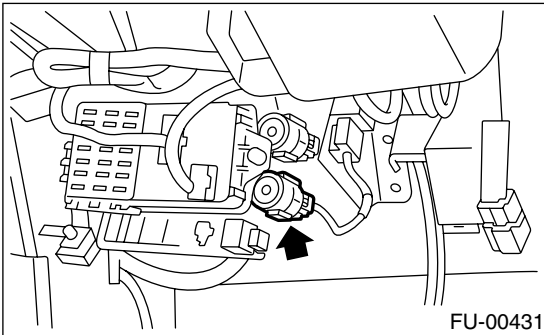

- 4) Remove main relay from bracket.

### B: INSTALLATION

Install in the reverse order of removal.

## 21. Fuel Pump Relay

### A: REMOVAL

- 1) Disconnect battery ground cable.

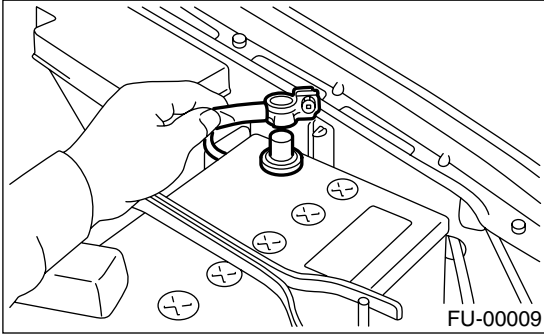

- 2) Remove lower cover of driver side.
- 3) Disconnect connector from fuel pump relay.

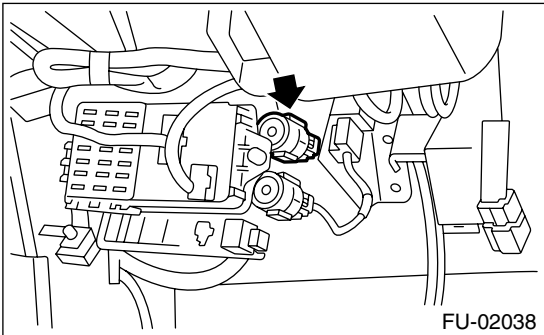

- 4) Remove fuel pump relay from bracket.

### B: INSTALLATION

Install in the reverse order of removal.

# ELECTRONIC CONTROL THROTTLE RELAY

FUEL INJECTION (FUEL SYSTEMS)

---

## 22. Electronic Control Throttle Relay

### A: REMOVAL

1) Disconnect battery ground cable.

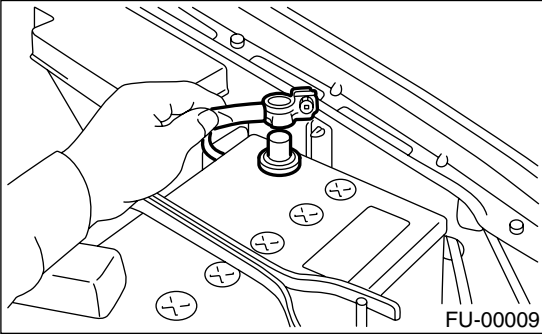

2) Disconnect connector from electronic control throttle relay of passenger side.

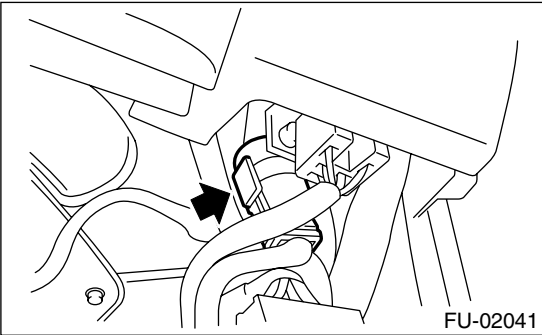

### B: INSTALLATION

Install in the reverse order of removal.

### 23. Fuel

#### A: OPERATION

##### 1. RELEASING OF FUEL PRESSURE

###### WARNING:

- Place “NO FIRE” signs near the working area.
- Be careful not to spill fuel on the floor.

- 1) Disconnect connector from fuel pump relay.

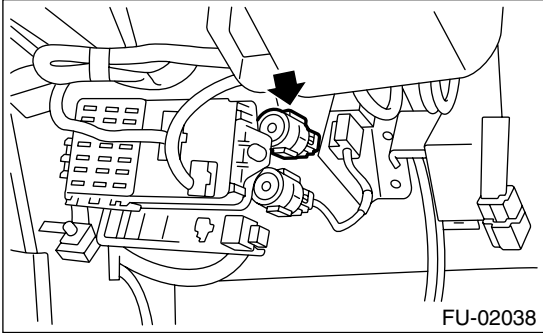

- 2) Start the engine and run it until it stalls.
- 3) After the engine stalls, crank it for five more seconds.
- 4) Turn ignition switch to OFF.

##### 2. DRAINING FUEL

###### WARNING:

- Place “NO FIRE” signs near the working area.
- Be careful not to spill fuel on the floor.

- 1) Set vehicle on the lift.
- 2) Disconnect battery ground cable.

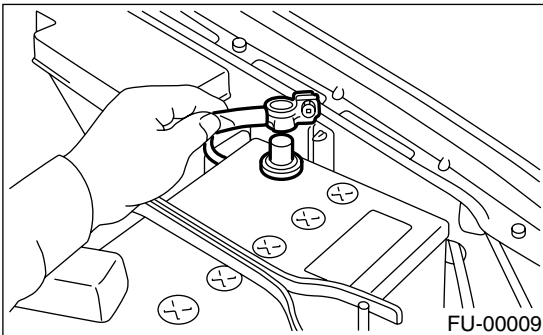

- 3) Lift-up the vehicle.
- 4) Remove front right side fuel tank cover.

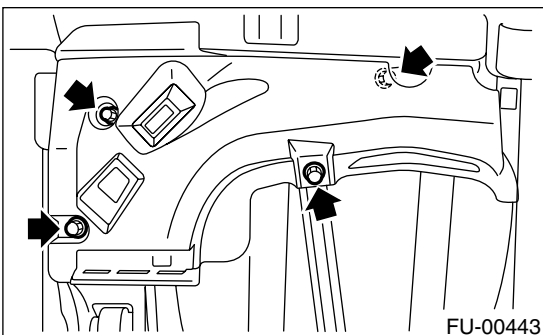

- 5) Drain fuel from fuel tank.  
Set a container under the vehicle and remove drain plug from fuel tank.

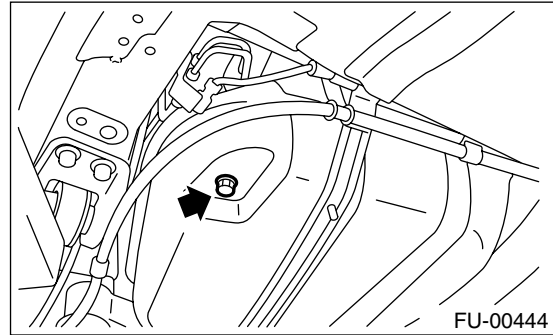

- 6) Tighten fuel drain plug.

###### NOTE:

Always use new gaskets.

###### **Tightening torque:**

**26 N·m (2.65 kgf-m, 19.2 ft-lb)**

- 7) Install front right side tank cover.

###### **Tightening torque:**

**18 N·m (1.8 kgf-m, 13.0 ft-lb)**

- 8) Lower the vehicle.
- 9) Remove sub service hole cover.

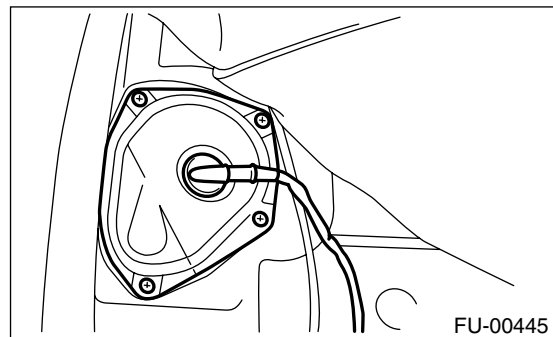

- 10) Disconnect connector from fuel sub level sensor.

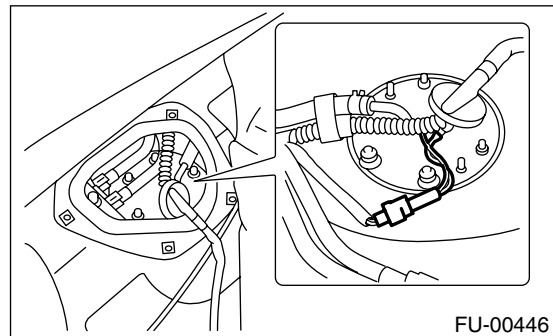

# FUEL

## FUEL INJECTION (FUEL SYSTEMS)

11) Disconnect fuel jet pump hose.

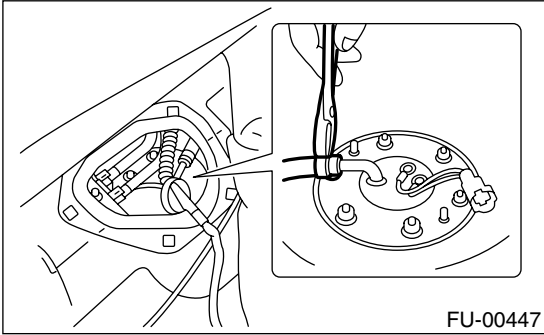

(1) Connect fuel jet pump hose.

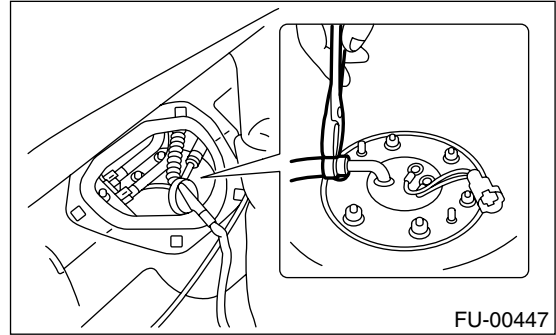

12) Remove fuel sub level sensor.

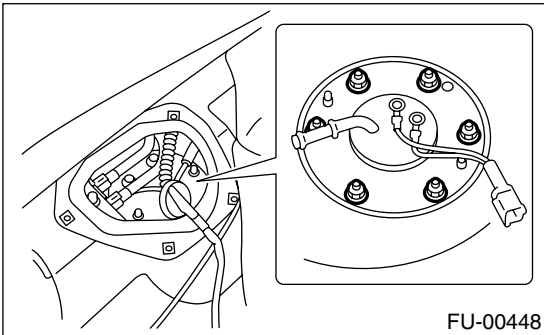

(2) Connect connector from fuel sub level sensor.

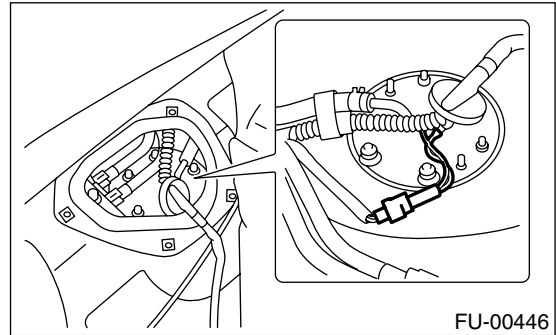

13) Drain fuel from fuel tank by using hand pump.

**WARNING:**

**Do not use a motor pump when draining fuel.**

14) After draining fuel, reinstall fuel sub level sensor.

**Tightening torque:**

**T: 4.4 N·m (0.45 kgf-m, 3.3 ft-lb)**

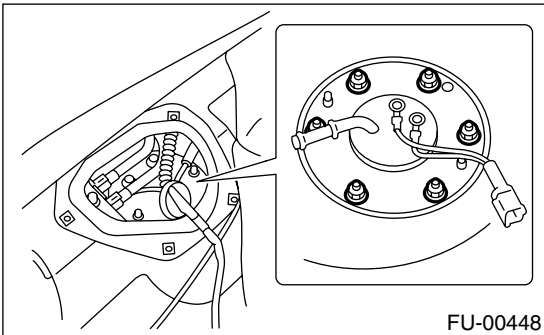

(3) Install sub service hole cover.

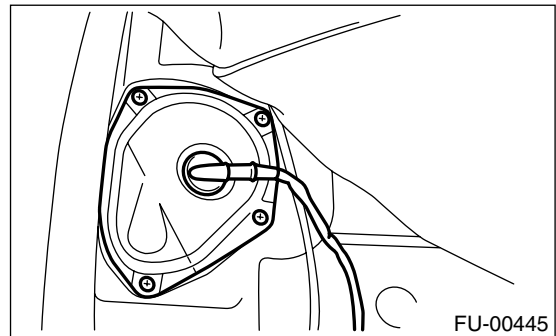

(4) Set rear seat and floor mat.

**NOTE:**

If you have not removed fuel tank yet, proceed with the procedure below for installation.

### 24. Fuel Tank

#### A: REMOVAL

- 1) Set vehicle on the lift.
- 2) Release fuel pressure. <Ref. to FU(H4SO U5)-53, RELEASING OF FUEL PRESSURE, OPERATION, Fuel.>
- 3) Drain fuel from fuel tank. <Ref. to FU(H4SO U5)-53, DRAINING FUEL, OPERATION, Fuel.>
- 4) Remove holder clip which secures fuel tank cord on bracket.

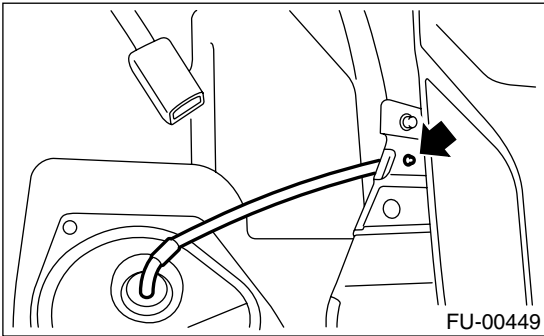

- 5) Disconnect connector of fuel tank cord to rear harness.

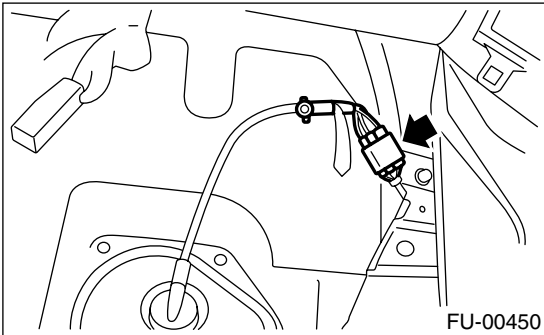

- 6) Push grommet which holds fuel tank cord on service hole cover into body side.

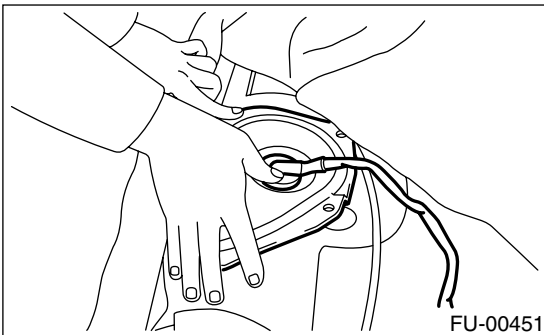

- 7) Separate quick connector of fuel delivery (A) and return hose (B). <Ref. to FU(H4SO U5)-77, REMOVAL, REMOVAL, Fuel Delivery, Return and Evaporation Lines.>

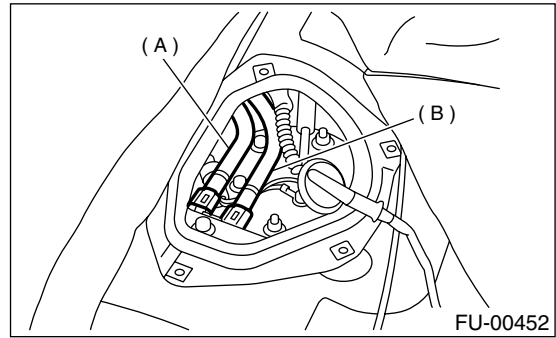

- 8) Remove parking brake cable.
  - (1) Remove console box. <Ref. to EI-45, REMOVAL, Console Box.>
  - (2) Remove parking brake bracket and disconnect parking brake cable from equalizer. <Ref. to PB-6, REMOVAL, Parking Brake Cable.>
- 9) Remove trunk trim. (Sedan model) <Ref. to EI-59, REMOVAL, Trunk Trim.>
- 10) Remove rear quarter lower trim. (Wagon model) <Ref. to EI-52, WAGON, REMOVAL, Rear Quarter Trim.>
- 11) Remove pipe protector.

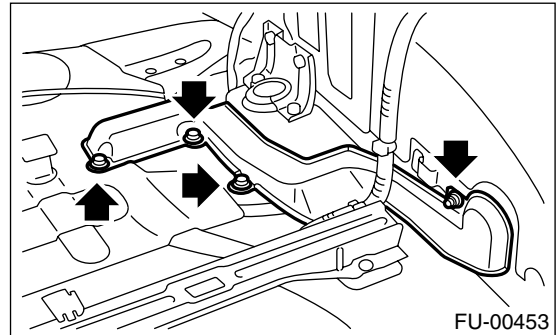

- 12) Separate quick connector of evaporation pipe. <Ref. to FU(H4SO U5)-77, REMOVAL, Fuel Delivery, Return and Evaporation Lines.>

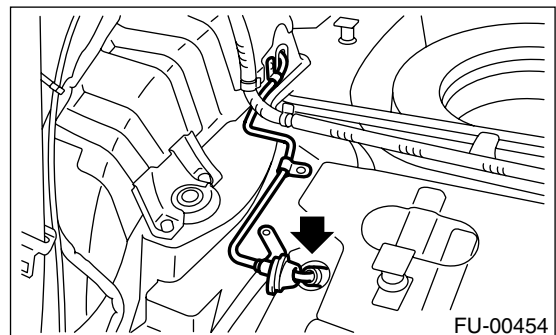

- 13) Remove wheel nuts from rear wheels.
- 14) Lift-up the vehicle.

# FUEL TANK

## FUEL INJECTION (FUEL SYSTEMS)

- 15) Remove rear wheel.
- 16) Remove front side fuel tank cover.

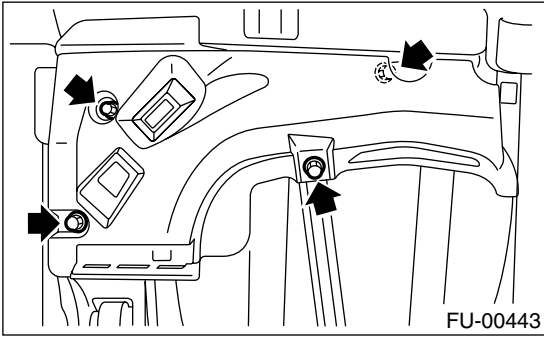

- 17) Remove rear exhaust pipe and muffler.

**NOTE:**

To facilitate removal, apply a coat of SUBARU CRC to matching area of rubber cushions in advance.

**SUBARU CRC (Part No. 004301003)**

- (1) Separate front exhaust pipe and rear exhaust pipe.

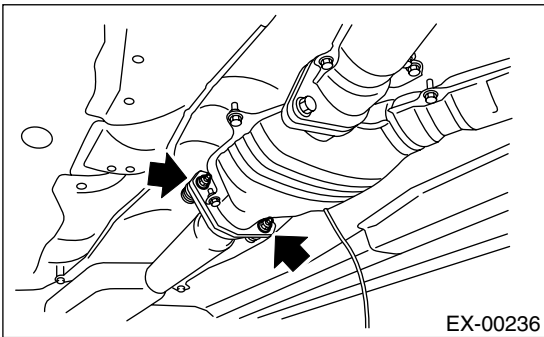

- (2) Remove left and right rubber cushions.

**CAUTION:**

Be careful not to pull down muffler.

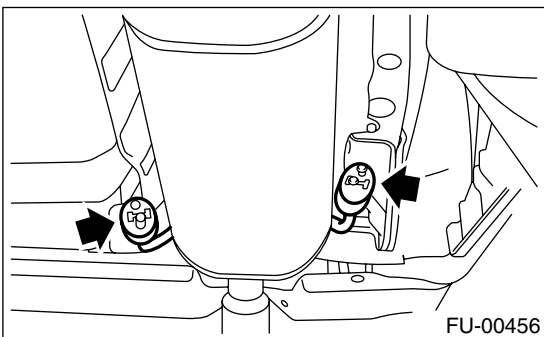

- (3) Remove front rubber cushion and detach muffler assembly.

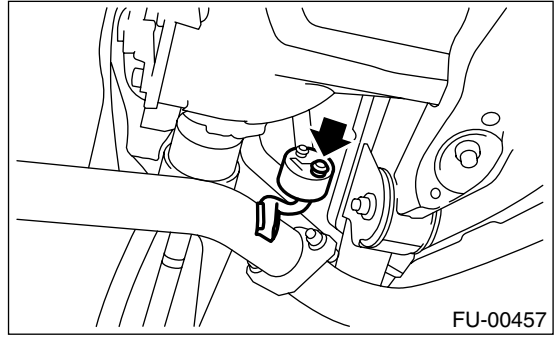

- 18) Remove propeller shaft. <Ref. to DS-15, REMOVAL, Propeller Shaft.>

- 19) Disconnect connector from ABS sensor.

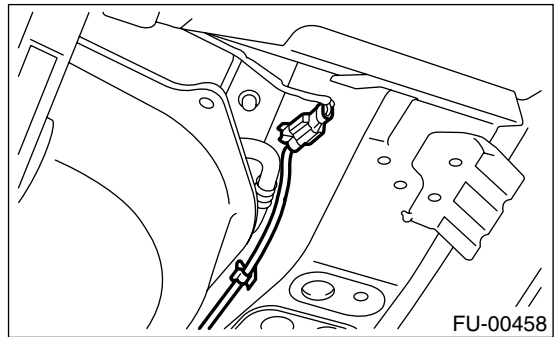

- 20) Remove bolts which hold parking brake cable holding bracket.

- 21) Remove parking brake cable from cabin by forcibly pulling it backward.

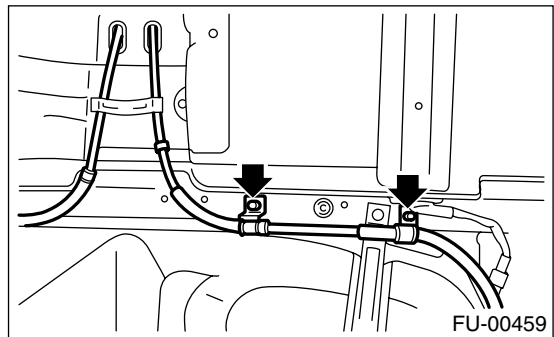

- 22) Remove bolts which hold parking brake cable holding bracket.

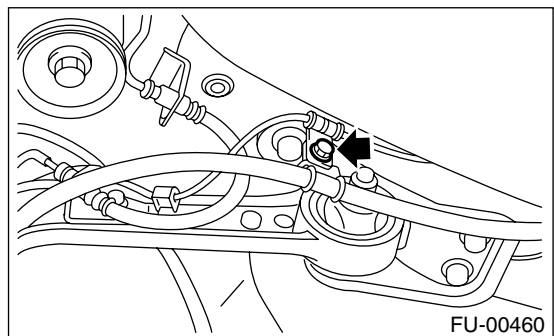



# FUEL TANK

## FUEL INJECTION (FUEL SYSTEMS)

23) Remove bolts which hold rear brake hoses holding bracket.

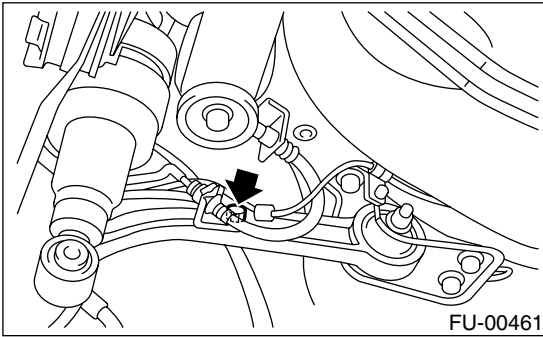

24) Remove rear brake caliper, then tie it up to the body side of the vehicle as shown in figure.

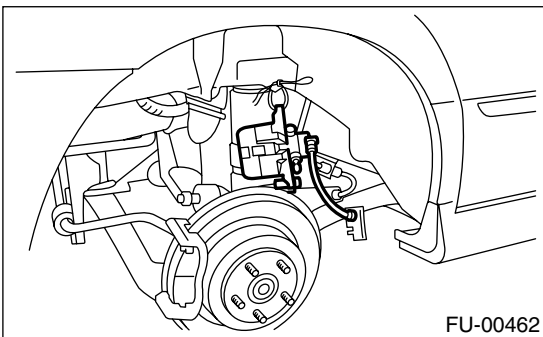

25) Remove rear suspension assembly.

### WARNING:

**A helper is required to perform this work.**

- (1) Support rear differential with transmission jack.
- (2) Remove bolt which holds rear shock absorber to rear suspension arm.

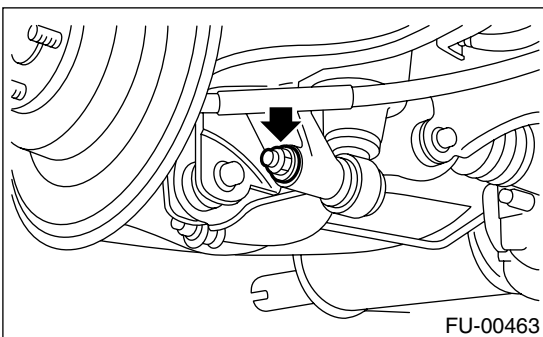

(3) Remove bolts which secure rear suspension assembly to body.

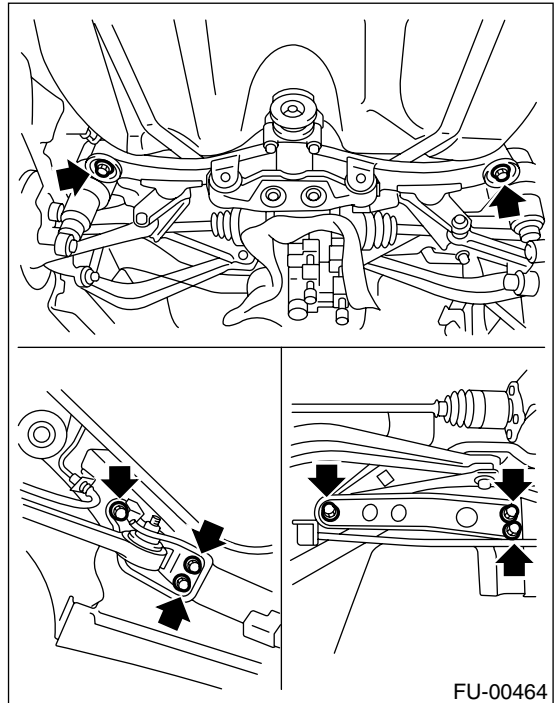

- (4) Remove rear suspension assembly.
- 26) Remove rear side fuel tank cover.

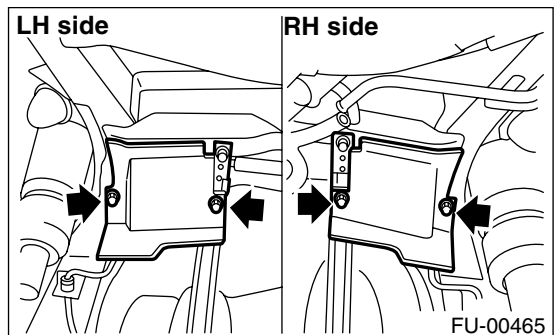

27) Disconnect fuel filler hose (A) and fuel tank pressure sensor hose (B).

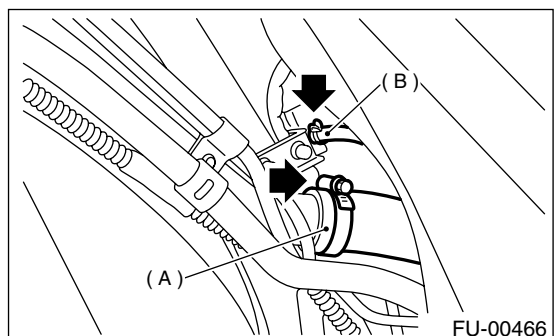

# FUEL TANK

## FUEL INJECTION (FUEL SYSTEMS)

28) Disconnect air vent hose (A) from evaporation pipe assembly and disconnect evaporation hose (B) from pressure control solenoid valve.

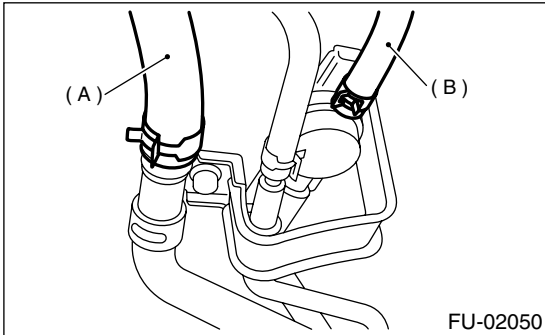

3) Connect air vent hose (A) to evaporation pipe assembly and connect evaporation hose (B) to pressure control solenoid valve.

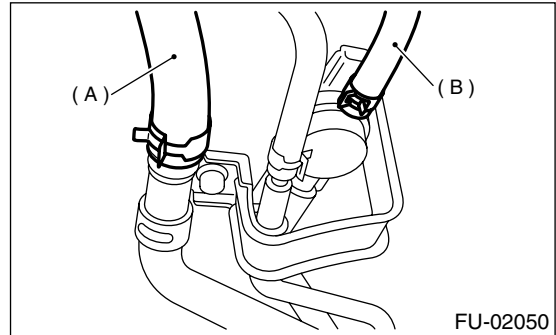

29) Support fuel tank with transmission jack, remove bolts from bands and dismount fuel tank from the vehicle.

### WARNING:

**A helper is required to perform this work.**

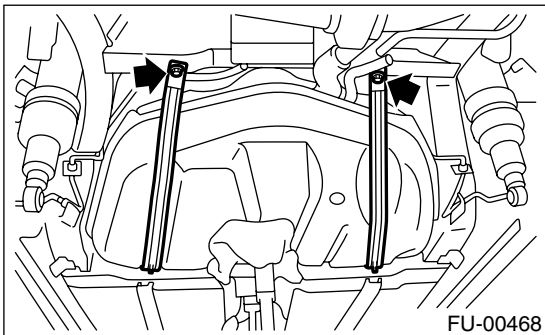

4) Connect fuel filler hose (A) and fuel tank pressure sensor hose (B).

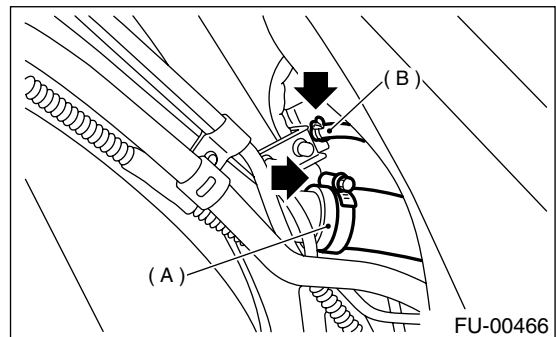

5) Tighten band mounting bolts.

### Tightening torque:

**33 N·m (3.4 kgf-m, 25 ft-lb)**

## B: INSTALLATION

1) Support fuel tank with transmission jack and push fuel tank harness into access hole with grommet.

2) Set fuel tank and temporarily tighten bolts of fuel tank bands.

### WARNING:

**A helper is required to perform this work.**

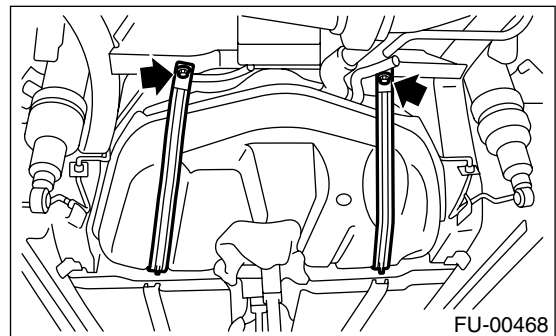
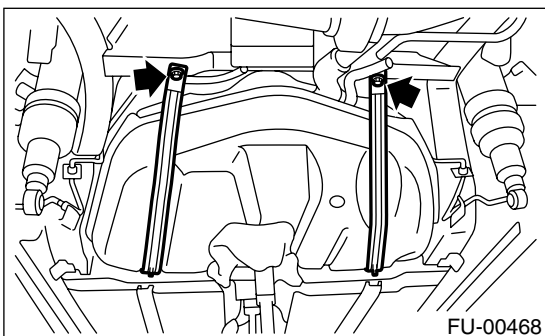

6) Install rear side fuel tank cover.

# FUEL TANK

FUEL INJECTION (FUEL SYSTEMS)

**Tightening torque:**  
**18 N·m (1.8 kgf·m, 13.0 ft·lb)**

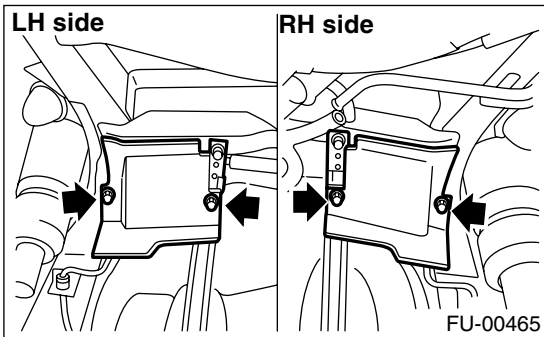

7) Install rear suspension assembly.

**WARNING:**

**A helper is required to perform this work.**

(1) Support rear suspension assembly and then tighten bolts which secure rear suspension assembly.

**Tightening torque:**

**T1: 172 N·m (17.5 kgf·m, 127 ft·lb)**

**T2: 108 N·m (11.0 kgf·m, 80 ft·lb)**

**T3: 66 N·m (6.7 kgf·m, 48 ft·lb)**

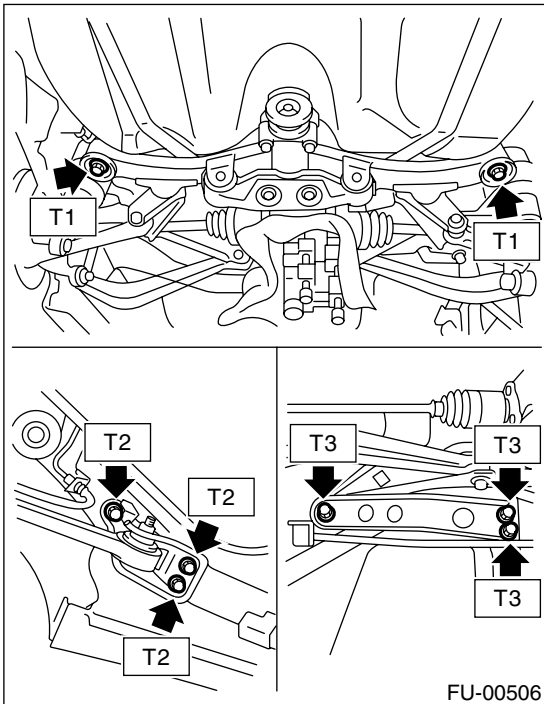

(2) Tighten bolt which holds rear shock absorber to rear suspension arm. <Ref. to RS-14, INSTALLATION, Link Upper.>

**Tightening torque:**  
**157 N·m (16 kgf·m, 116 ft·lb)**

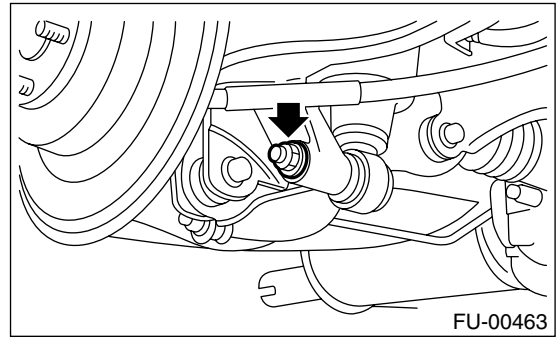

8) Install rear brake caliper. <Ref. to BR-22, INSTALLATION, Rear Disc Brake Assembly.>

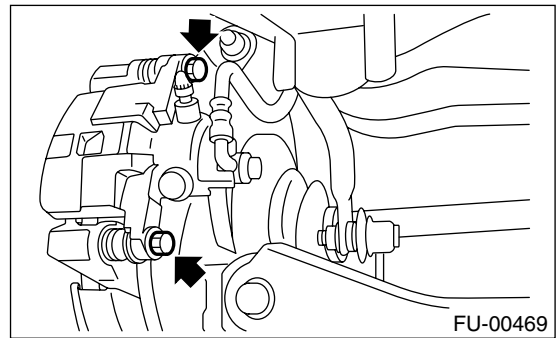

9) Tighten bolts which hold rear brake hoses holding bracket.

**Tightening torque:**

**33 N·m (3.4 kgf·m, 25 ft·lb)**

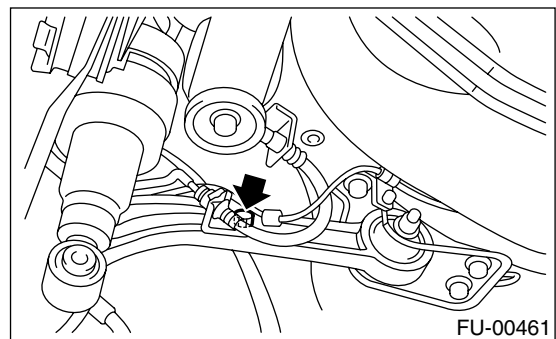

10) Install parking brake cable to cabin by forcibly pushing it forward.

11) Tighten bolts which hold parking brake cable holding bracket.

# FUEL TANK

## FUEL INJECTION (FUEL SYSTEMS)

### Tightening torque:

**18 N·m (1.8 kgf-m, 13.0 ft-lb)**

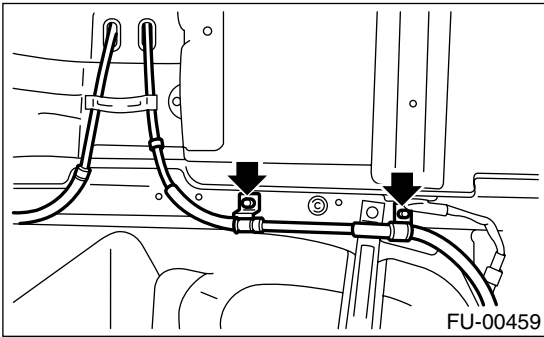

### Tightening torque:

**32 N·m (3.3 kgf-m, 23.9 ft-lb)**

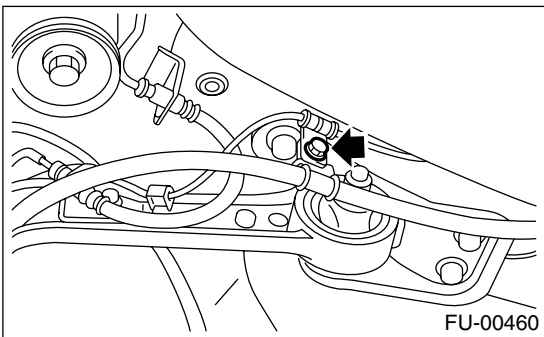

12) Connect connector to ABS sensor.

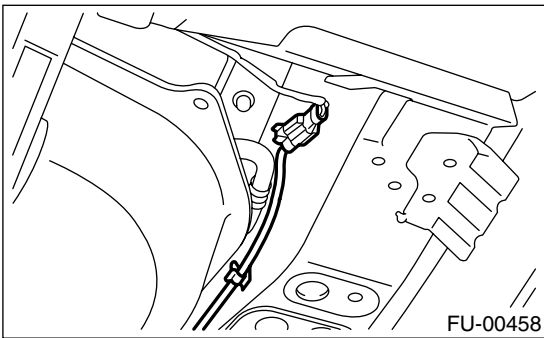

13) Install propeller shaft. <Ref. to DS-16, INSTALLATION, Propeller Shaft.>

14) Install rear exhaust pipe and muffler.

### NOTE:

To facilitate the procedure, apply a coat of SUBARU CRC to matching area of rubber cushions in advance.

**SUBARU CRC (Part No. 004301003)**

(1) Install left and right rubber cushions.

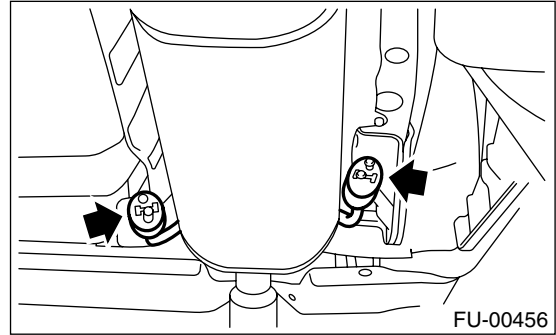

(2) Install front rubber cushion and attach muffler assembly.

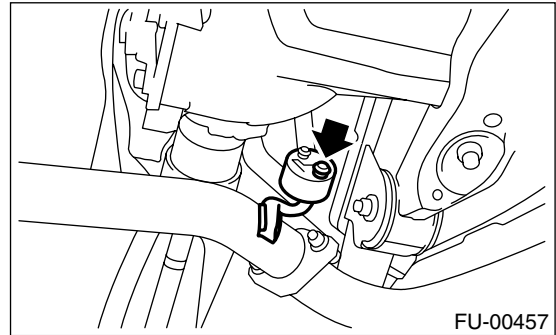

(3) Install rear exhaust pipe to front exhaust pipe.

### Tightening torque:

**18 N·m (1.8 kgf-m, 13.0 ft-lb)**

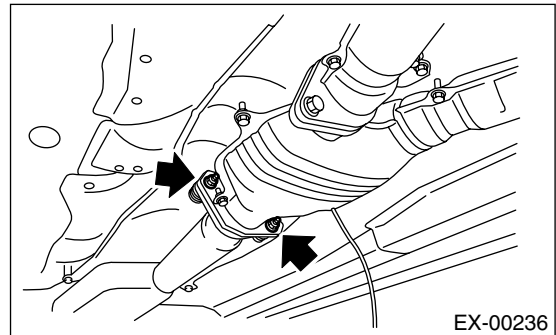

15) Install front side fuel tank cover.

### Tightening torque:

**18 N·m (1.8 kgf-m, 13.0 ft-lb)**

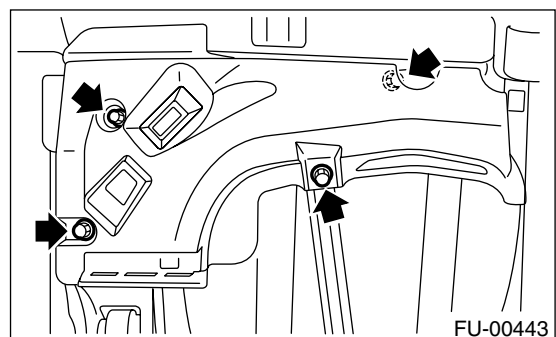

# FUEL TANK

## FUEL INJECTION (FUEL SYSTEMS)

- 16) Install rear wheel.
- 17) Lower the vehicle.
- 18) Tighten wheel nuts to rear wheel.
- 19) Install parking brake cable. <Ref. to PB-5, INSTALLATION, Parking Brake Lever.>
- 20) Install console box. <Ref. to EI-45, INSTALLATION, Console Box.>
- 21) Connect fuel hoses and hold them with quick connector. <Ref. to FU(H4SO U5)-78, INSTALLATION, Fuel Delivery, Return and Evaporation Lines.>

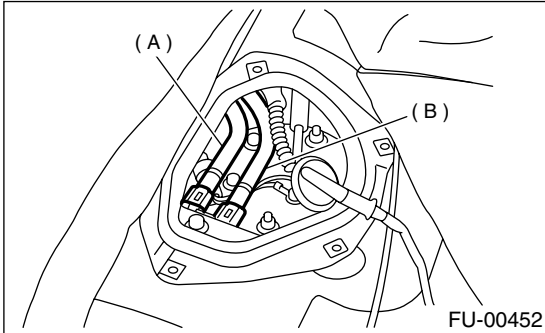

- (A) Delivery hose  
(B) Return hose

- 22) Connect evaporation pipe and hold it with quick connector. <Ref. to FU(H4SO U5)-78, INSTALLATION, Fuel Delivery, Return and Evaporation Lines.>

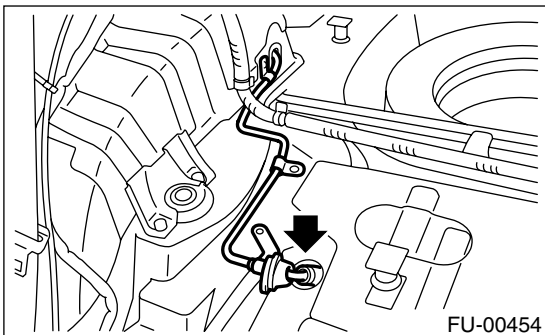

- 23) Install pipe protector.

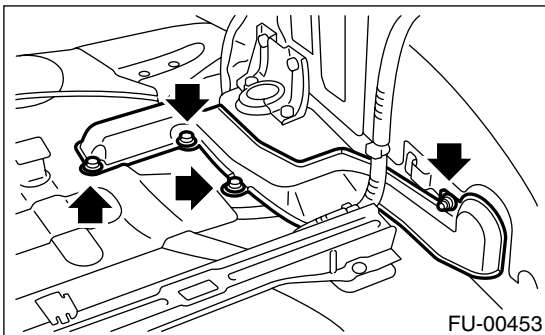

- 24) Install trunk room trim. (Sedan model)
- 25) Install luggage room trim. (Wagon model)

- 26) Connect fuel jet pump hose.

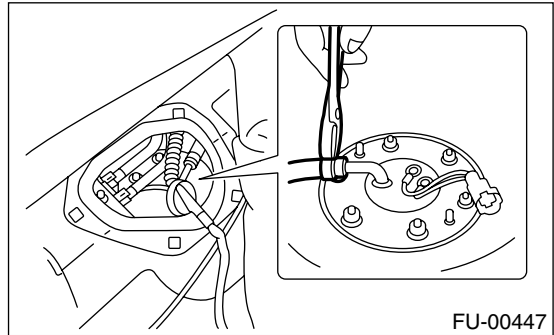

- 27) Connect connector to fuel sub level sensor.

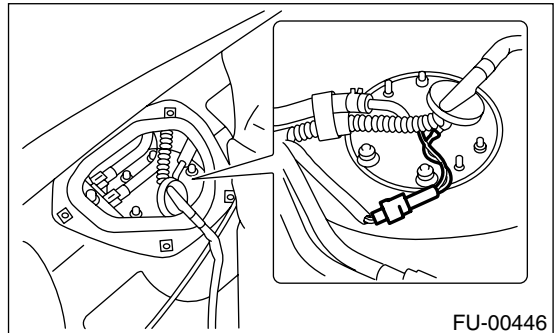

- 28) Install sub service hole cover.

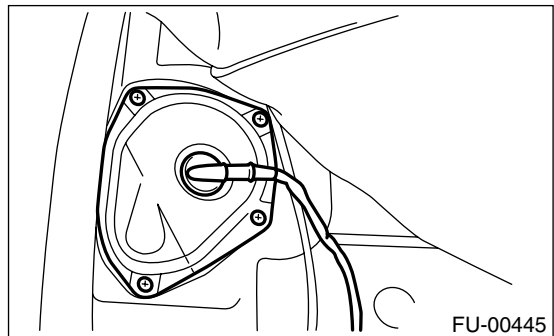

- 29) Connect connectors to fuel tank cord and plug service hole with grommet.

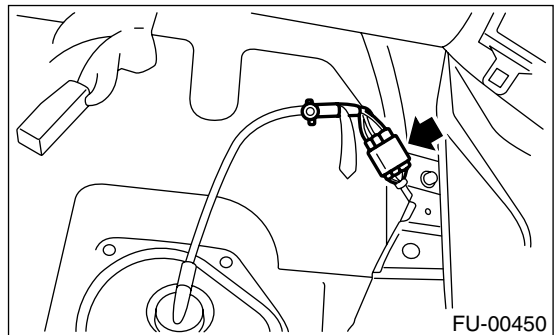

# FUEL TANK

## FUEL INJECTION (FUEL SYSTEMS)

---

30) Install holder clip which secures fuel tank cord on bracket.

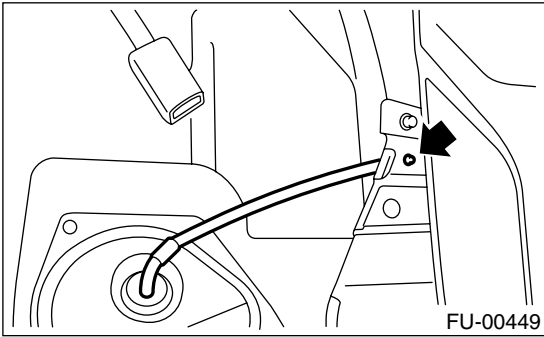

31) Set rear seat and floor mat.

32) Connect connector to fuel pump relay.

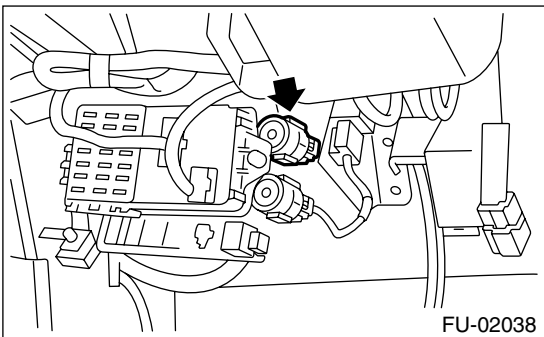

33) Adjust parking brake lever stroke. <Ref. to PB-5, ADJUSTMENT, Parking Brake Lever.>

34) Check wheel alignment and adjust if necessary. <Ref. to FS-6, INSPECTION, Wheel Alignment.>

### **C: INSPECTION**

1) Make sure there are no cracks, holes, or other damage on the fuel tank.

2) Make sure that the fuel hoses and fuel pipes are not cracked and that connections are tight.

## 25. Fuel Filler Pipe

### A: REMOVAL

**WARNING:**

- Place “NO FIRE” signs near the working area.
- Be careful not to spill fuel on the floor.

- 1) Drain fuel from fuel tank. <Ref. to FU(H4SO U5)-53, DRAINING FUEL, OPERATION, Fuel.>
- 2) Remove rear exhaust pipe and muffler.

**NOTE:**

To facilitate removal, apply a coat of SUBARU CRC to matching area of rubber cushions in advance.

**SUBARU CRC (Part No. 004301003)**

- (1) Separate front exhaust pipe and rear exhaust pipe.

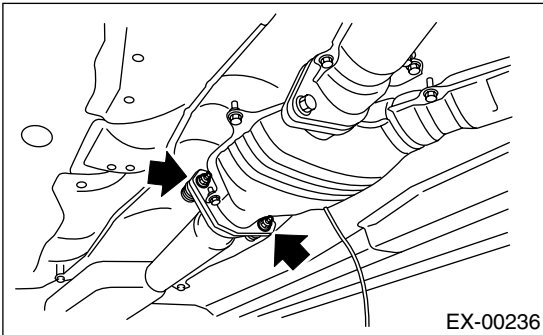

- (2) Remove left and right rubber cushions.

**CAUTION:**

Be careful not to pull down muffler.

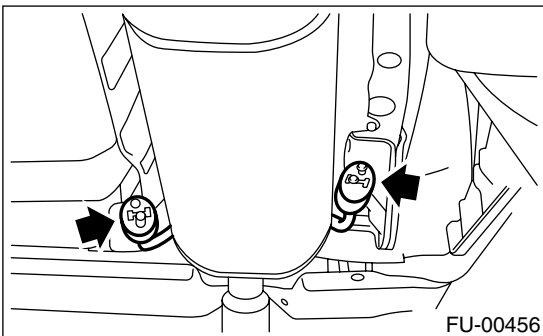

- (3) Remove front rubber cushion and detach muffler assembly.

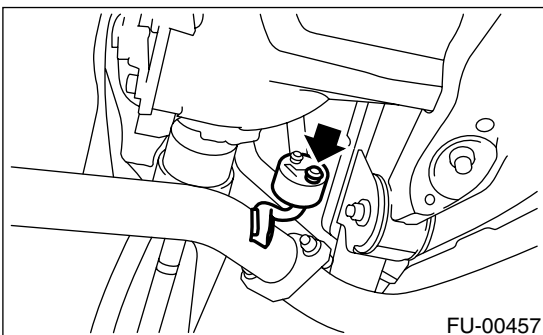

- 3) Remove heat sealed cover.

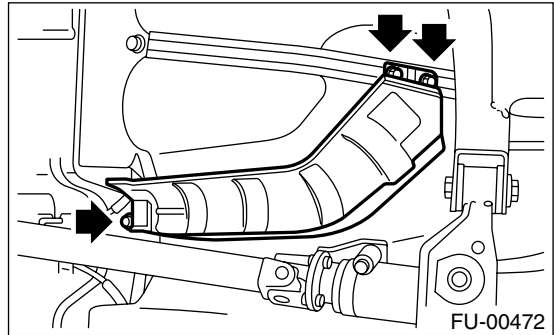

- 4) Place transmission jack under sub frame.

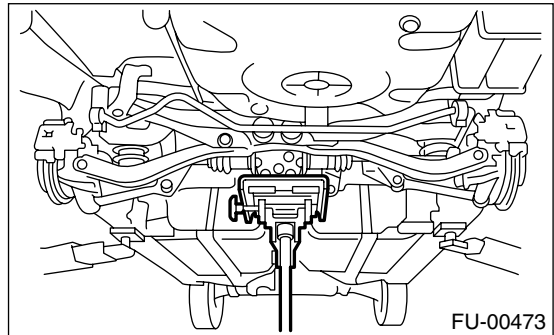

- 5) Remove bolt which holds rear shock absorber to rear suspension arm.

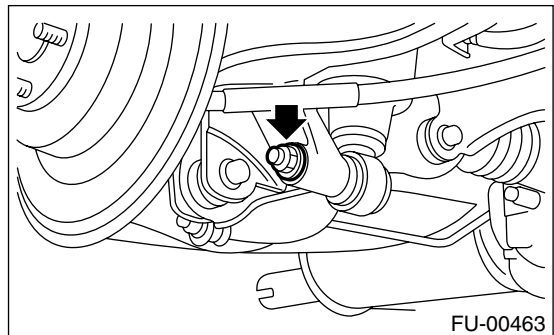

# FUEL FILLER PIPE

## FUEL INJECTION (FUEL SYSTEMS)

6) Remove bolts which hold rear sub frame on body.

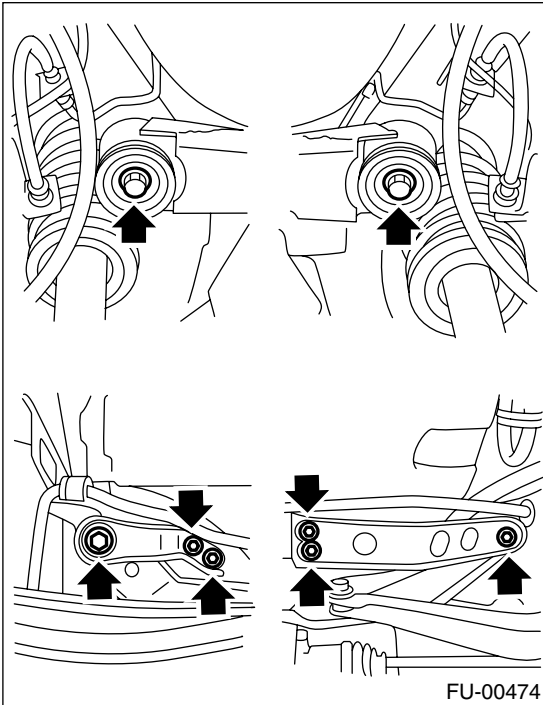

7) Lower the rear sub frame.

**CAUTION:**

**Be sure to lower sub frame slowly.**

**A = 150 mm (5.91 in)**

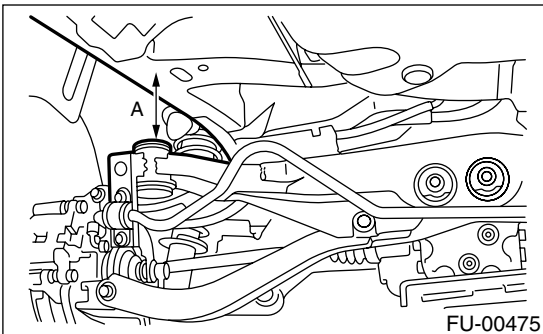

8) Remove fuel filler pipe protector.

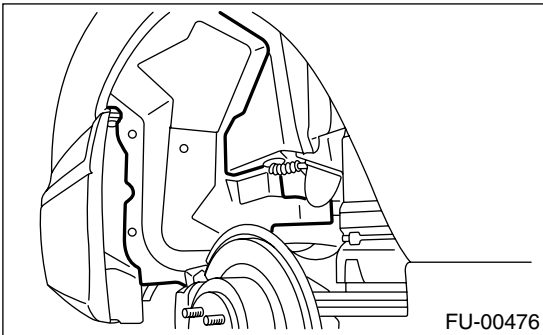

9) Disconnect air vent hose (A) and evaporation hose (P) from evaporation pipe assembly.

10) Disconnect evaporation hose (C) from pressure control solenoid valve.

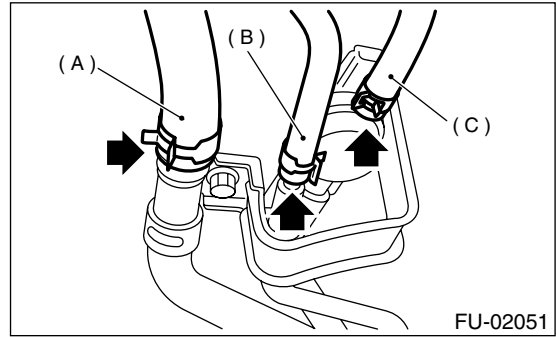

11) Remove bolt which holds evaporation pipe assembly on body.

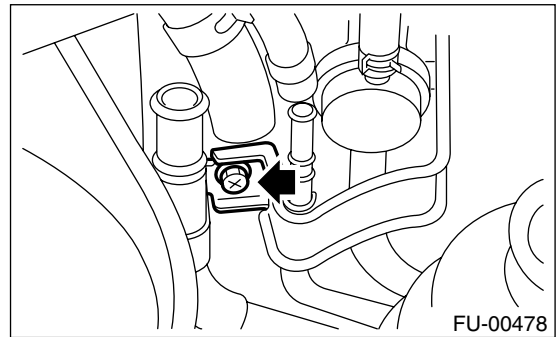

12) Disconnect fuel filler hose.

13) Remove bolt which holds fuel pressure sensor on fuel filler pipe and remove bolt which holds fuel filler pipe on body.

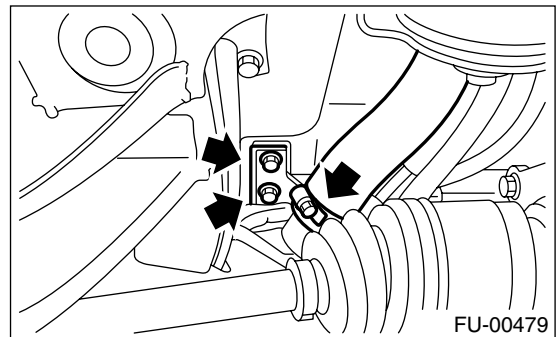

14) Disconnect canister hose from evaporation pipe assembly.

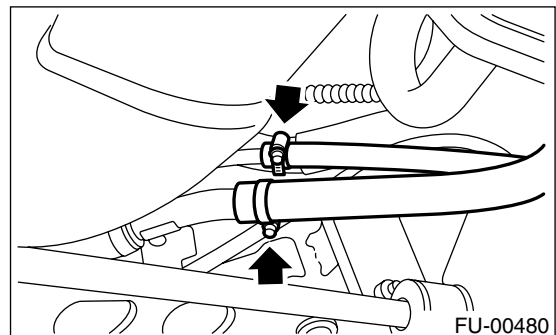



# FUEL FILLER PIPE

FUEL INJECTION (FUEL SYSTEMS)

15) Disconnect evaporation hose from fuel filler pipe.

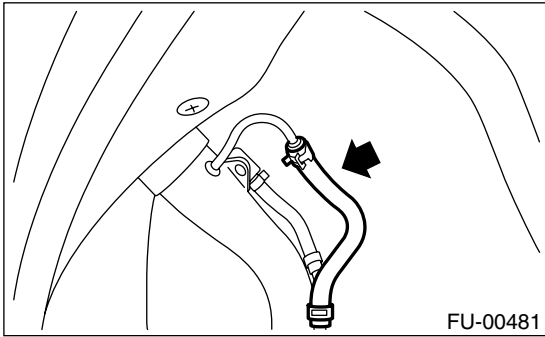

16) Remove bolt which holds fuel filler pipe to body.

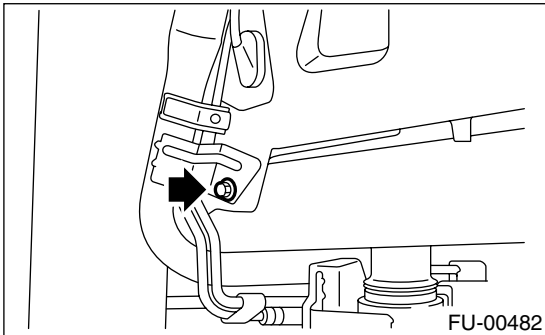

17) Remove fuel filler pipe from under side of the vehicle.

## B: INSTALLATION

1) Hold fuel filler flap open.  
2) Set fuel saucer (A) with rubber packing (C) and insert fuel filler pipe into hole from the inner side of apron.

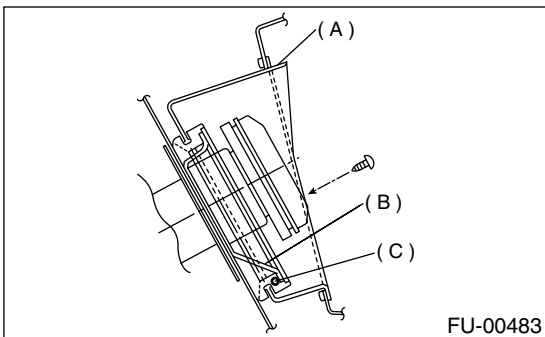

3) Align holes in fuel filler pipe neck and set cup (B), and tighten screws.

### NOTE:

If edges of rubber packing are folded toward the inside, straighten it with a screwdriver.

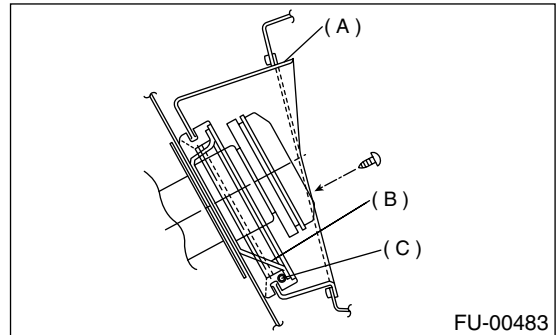

4) Tighten bolt which holds fuel filler pipe on body.

### Tightening torque:

**7.5 N·m (0.75 kgf-m, 5.4 ft-lb)**

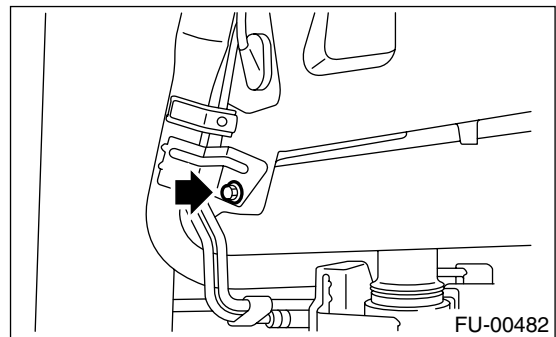

5) Insert evaporation hose approximately 25 to 30 mm (0.98 to 1.18 in) into the lower end of evaporation pipe and hold clip.

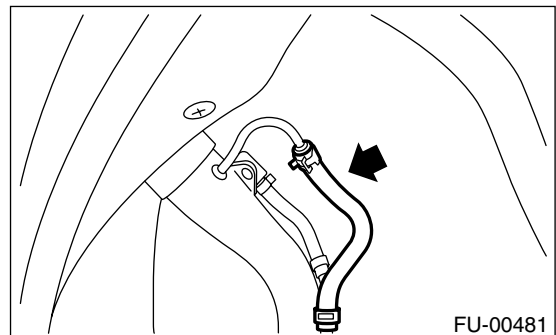

# FUEL FILLER PIPE

## FUEL INJECTION (FUEL SYSTEMS)

$L = 27.5 \pm 2.5 \text{ mm (1.083 \pm 0.098 in)}$

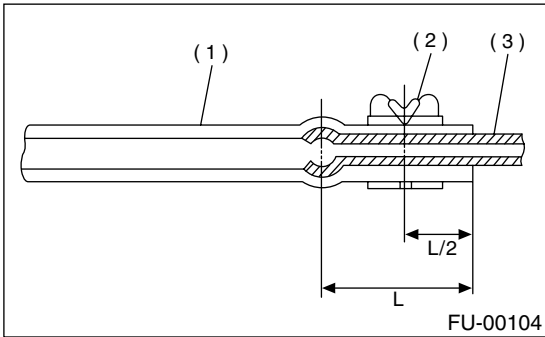

- (1) Hose
- (2) Clip
- (3) Pipe

6) Insert canister hoses approximately 25 to 30 mm (0.98 to 1.18 in) into the lower end of evaporation pipe assembly and tighten clamp.

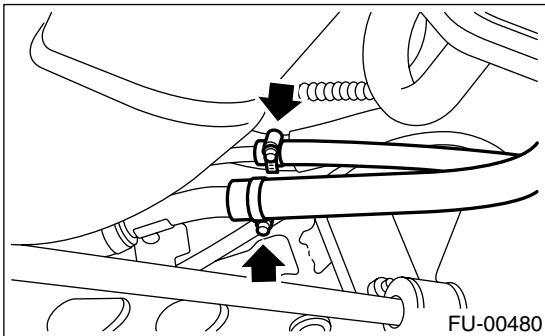

$L = 27.5 \pm 2.5 \text{ mm (1.083 \pm 0.098 in)}$

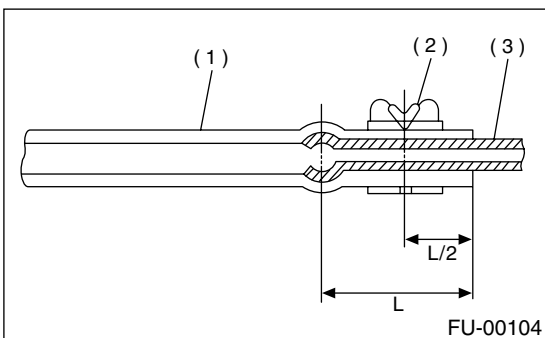

- (1) Hose
- (2) Clip
- (3) Pipe

7) Tighten bolt which holds evaporation pipe assembly on body.

**Tightening torque:**

**7.5 N·m (0.75 kgf-m, 5.4 ft-lb)**

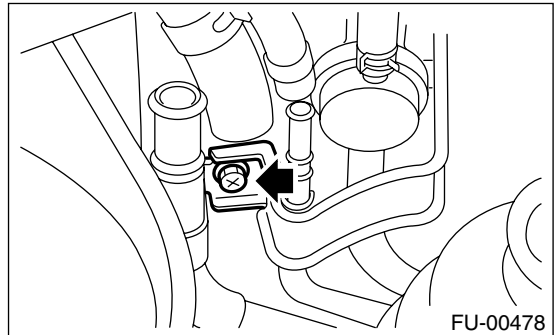

8) Insert air vent hose (A), evaporation hose (B) approximately 25 to 30 mm (0.98 to 1.18 in) into the lower end of evaporation pipe assembly and hold clip.

9) Insert evaporation hose (C) to pressure control solenoid valve and hold clip.

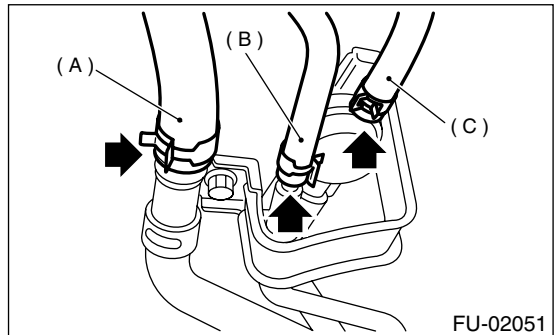

$L = 27.5 \pm 2.5 \text{ mm (1.083 \pm 0.098 in)}$

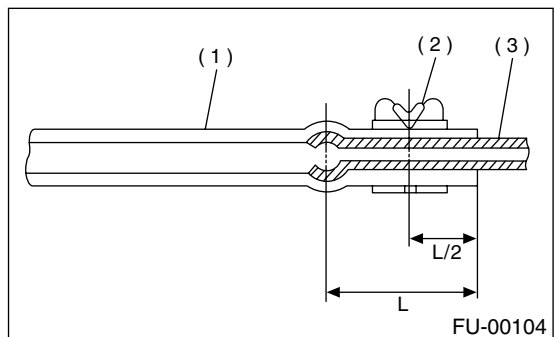

- (1) Hose
- (2) Clip
- (3) Pipe

10) Tighten bolt which holds fuel filler pipe on body and tighten bolt which holds fuel pressure sensor on fuel filler pipe.

**Tightening torque:**

**7.5 N·m (0.75 kgf-m, 5.4 ft-lb)**

# FUEL FILLER PIPE

FUEL INJECTION (FUEL SYSTEMS)

11) Insert fuel filler hose approximately 35 to 40 mm (1.38 to 1.57 in) over the lower end of fuel filler pipe and tighten clamp.

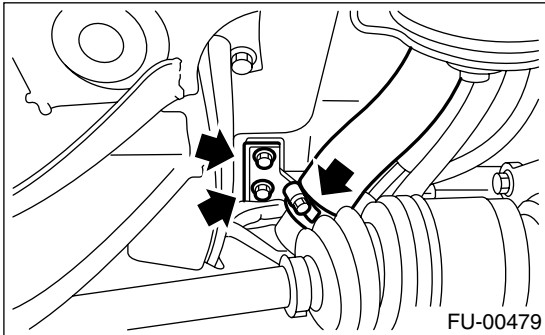

12) Jack-up the rear sub frame and tighten bolts which hold rear sub frame on body.

**Tightening torque:**

**T1: 66 N·m (6.7 kgf·m, 48.5 ft·lb)**

**T2: 172 N·m (17.5 kgf·m, 127 ft·lb)**

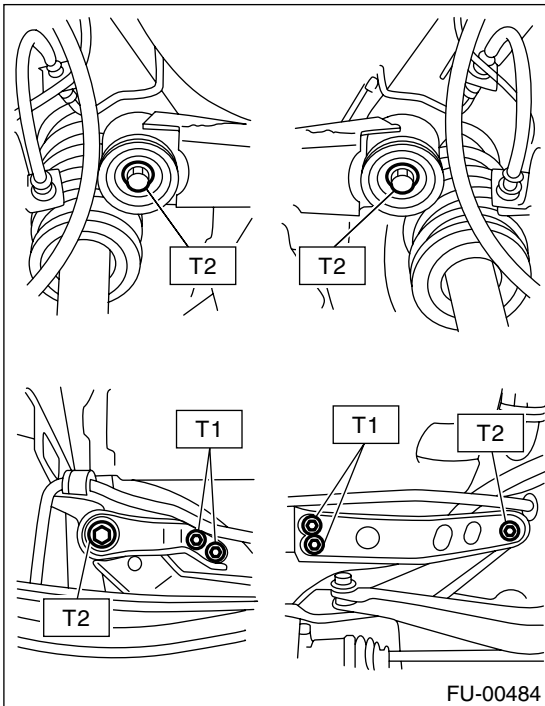

13) Tighten bolt which holds rear shock absorber to rear suspension arm. <Ref. to RS-17, INSTALLATION, Rear Shock Absorber.>

**Tightening torque:**

**157 N·m (16 kgf·m, 116 ft·lb)**

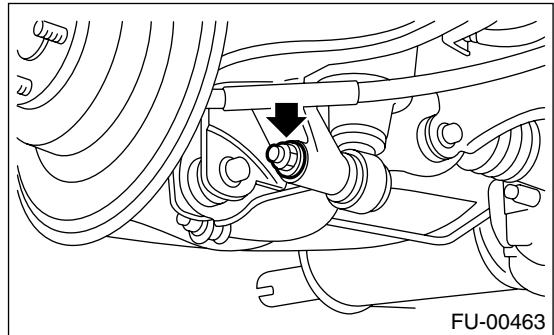

14) Install heat shield cover.

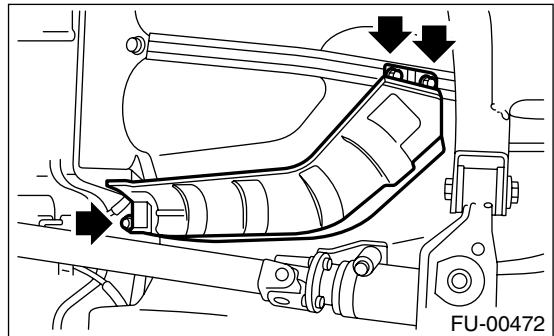

15) Install rear exhaust pipe and muffler.

**NOTE:**

To facilitate the procedure, apply a coat of SUBARU CRC to matching area of rubber cushions in advance.

**SUBARU CRC (Part No. 004301003)**

(1) Install left and right rubber cushions.

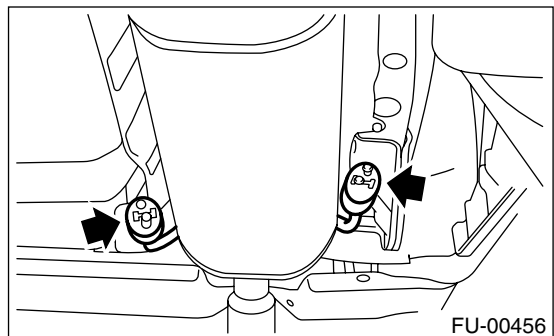

# FUEL FILLER PIPE

## FUEL INJECTION (FUEL SYSTEMS)

(2) Install front rubber cushion and attach muffler assembly.

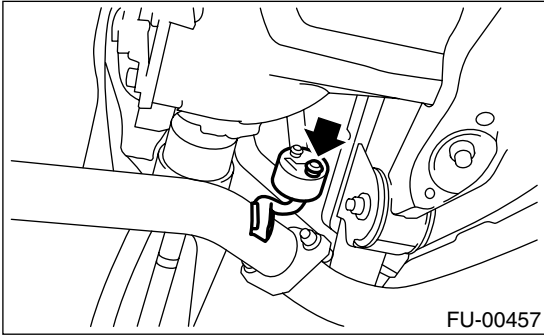

(3) Install rear exhaust pipe to front exhaust pipe.

**Tightening torque:**

**18 N·m (1.8 kgf-m, 13.0 ft-lb)**

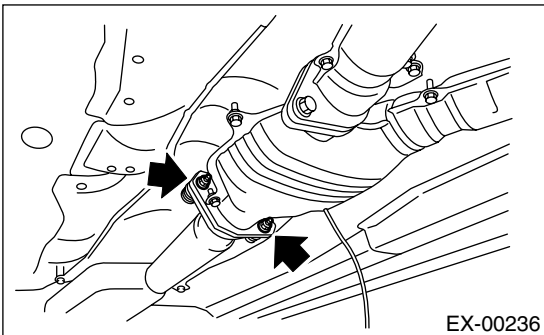

16) Install fuel filler pipe protector.

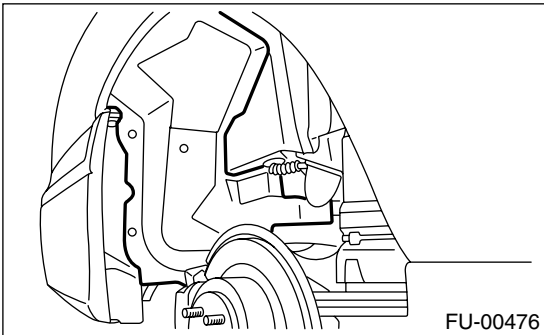

17) Install rear right wheel.

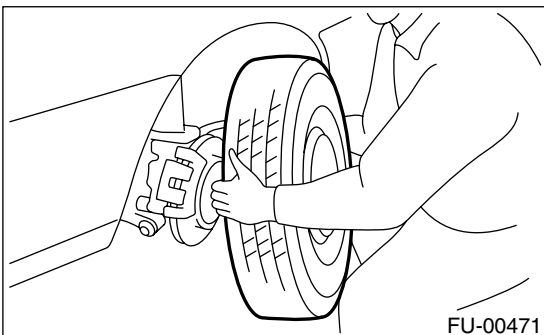

18) Lower the vehicle.

19) Tighten wheel nuts.

20) Connect battery ground terminal.

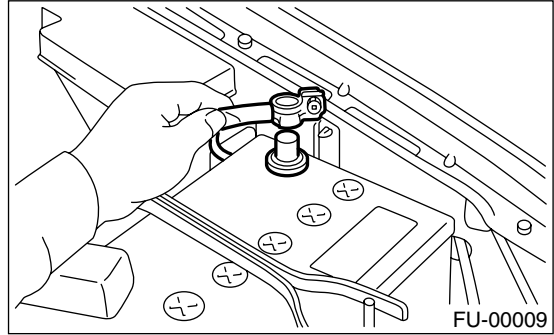

21) Remove fuel filler pipe to under side of the vehicle.

### C: DISASSEMBLY

1) Disconnect evaporation hose from evaporation pipe assembly.

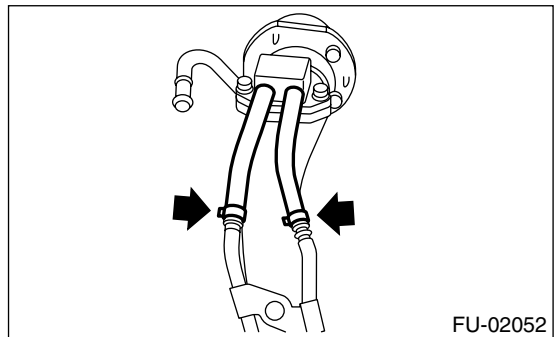

2) Remove shut valve from fuel filler pipe.

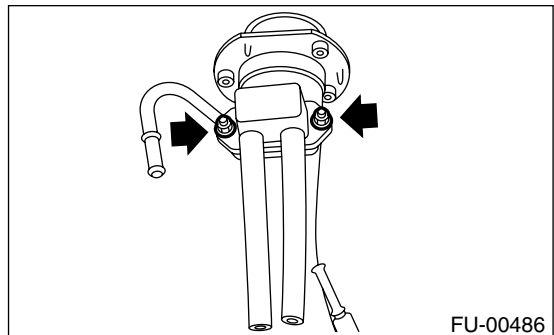

3) Remove nut which holds evaporation pipe assembly on fuel filler pipe.

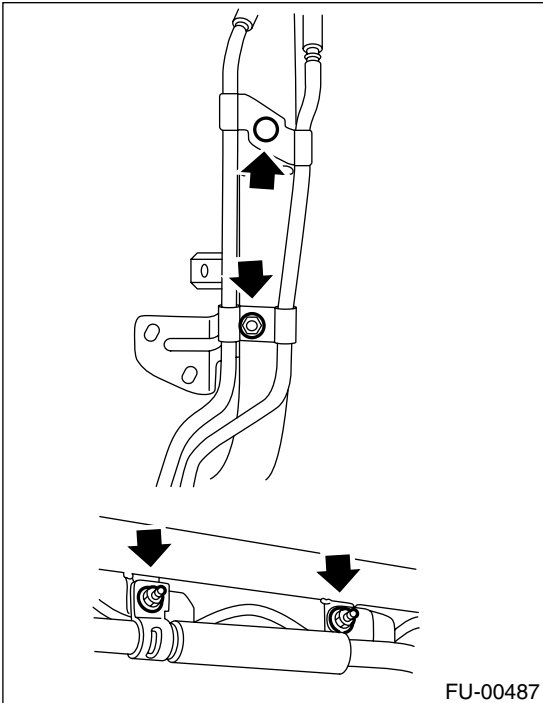

### **D: ASSEMBLY**

Assemble in the reverse order of disassembly.

# FUEL PUMP

## FUEL INJECTION (FUEL SYSTEMS)

### 26. Fuel Pump

#### A: REMOVAL

##### WARNING:

- Place “NO FIRE” signs near the working area.
- Be careful not to spill fuel on the floor.

##### NOTE:

Fuel pump assembly consists of fuel pump and fuel level sensor.

- 1) Release fuel pressure. <Ref. to FU(H4SO U5)-53, RELEASING OF FUEL PRESSURE, OPERATION, Fuel.>
- 2) Drain fuel from fuel tank. <Ref. to FU(H4SO U5)-53, DRAINING FUEL, OPERATION, Fuel.>
- 3) Raise rear seat and turn floor mat up.
- 4) Remove access hole lid.

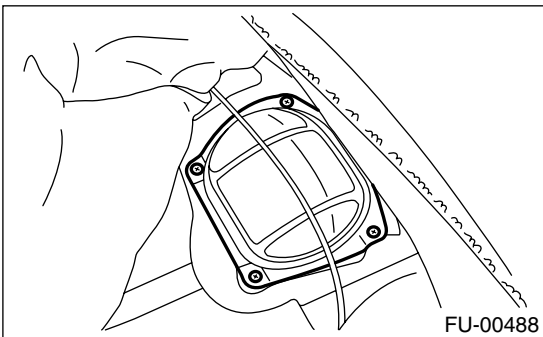

- 5) Disconnect connector from fuel pump.

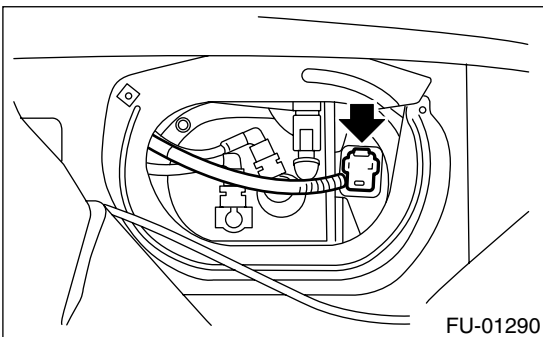

- 6) Disconnect quick connector, and then disconnect fuel delivery hose (A), return hose (B) and jet pump hose. <Ref. to FU(H4SO U5)-77, REMOVAL, Fuel Delivery, Return and Evaporation Lines.>

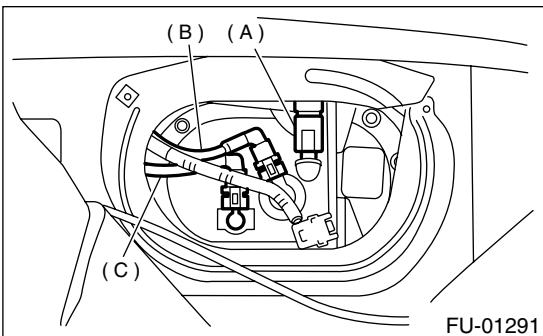

- 7) Remove nuts which install fuel pump assembly onto fuel tank.

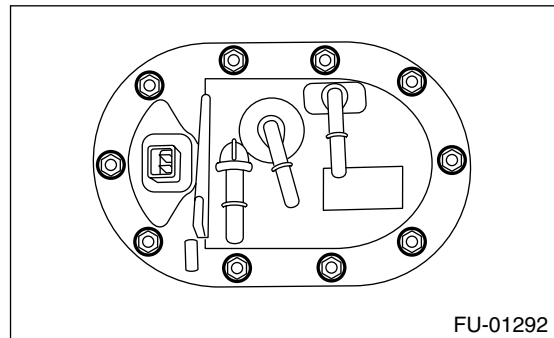

- 8) Remove fuel pump assembly from fuel tank.

#### B: INSTALLATION

Install in the reverse order of removal. Do the following:

- (1) Always use new gaskets.
- (2) Ensure sealing portion is free from fuel or foreign particles before installation.
- (3) Tighten nuts in alphabetical sequence shown in figure to specified torque.

##### Tightening torque:

**5.9 N·m (0.6 kgf·m, 4.3 ft·lb)**

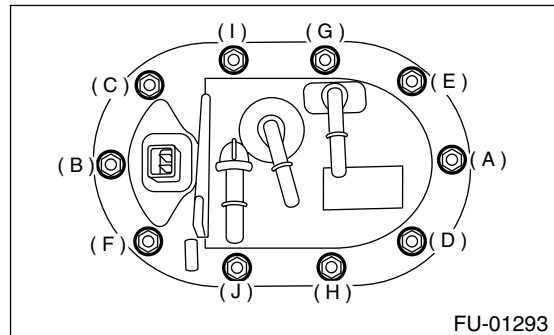

#### C: DISASSEMBLY

- 1) Remove fuel pump and pump holder.

##### NOTE:

When disassembling pump holder, be careful as it is installed with two pawls.

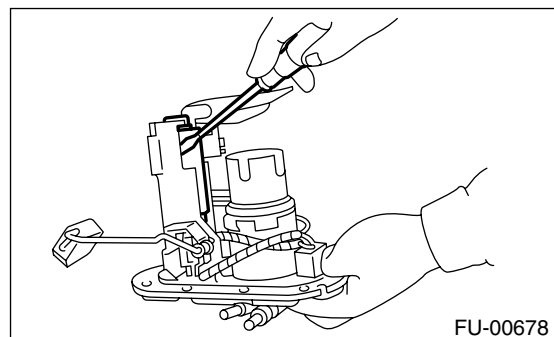

2) Disconnect connector from fuel pump.

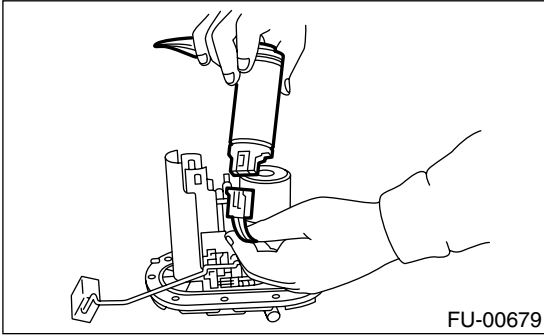

### D: ASSEMBLY

Assemble in the reverse order of disassembly.

### E: INSPECTION

Connect lead harness to connector terminal of fuel pump and apply battery power supply to check whether the pump operate.

#### WARNING:

- Wipe off the fuel completely.
- Keep battery as far apart from fuel pump as possible.
- Be sure to turn the battery supply ON and OFF on the battery side.
- Do not run fuel pump for a long time under non-load condition.

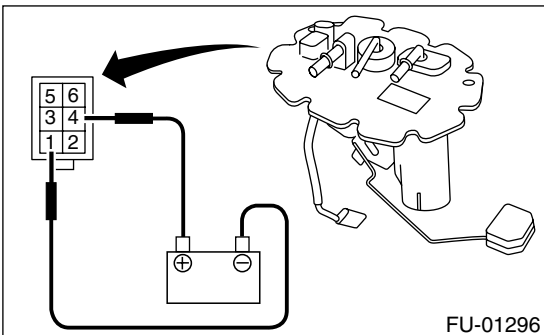

# FUEL LEVEL SENSOR

FUEL INJECTION (FUEL SYSTEMS)

## 27. Fuel Level Sensor

### A: REMOVAL

#### WARNING:

- Place “NO FIRE” signs near the working area.
- Be careful not to spill fuel on the floor.

#### NOTE:

Fuel level sensor is built in fuel pump assembly.

- 1) Remove fuel pump assembly. <Ref. to FU(H4SO U5)-70, REMOVAL, Fuel Pump.>
- 2) Disconnect connector from fuel pump bracket.

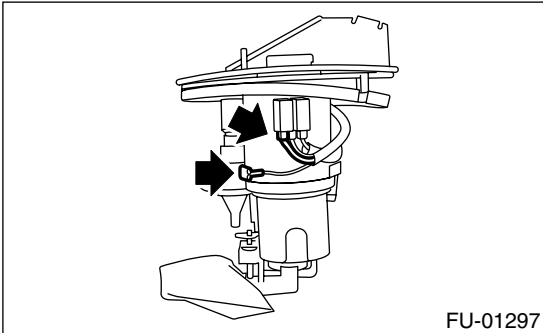

- 3) Pushing the pawls with a screwdriver, remove fuel level sensor by pulling it downwards.

#### NOTE:

If the retainer pawls are broken during removal, the fuel level sensor must be replaced with a new one.

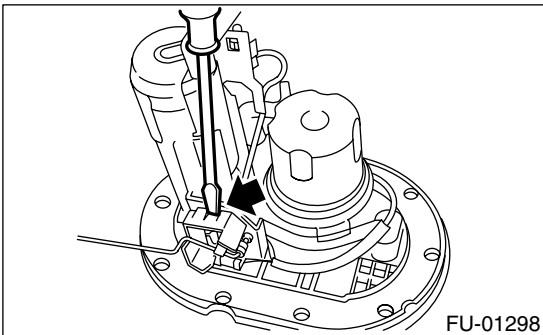

### B: INSTALLATION

Install in the reverse order of removal.

#### WARNING:

- Ground cable must be connected.
- Spark may occur and ignite if fuel is nearby.

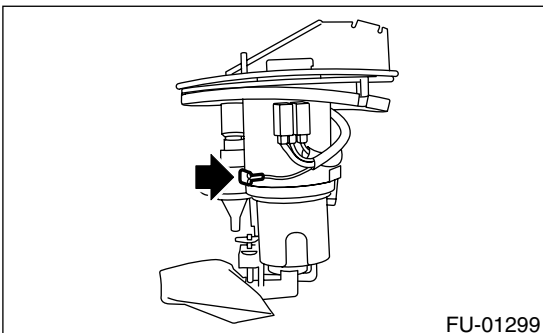

FU(H4SO U5)-72



# FUEL SUB LEVEL SENSOR

FUEL INJECTION (FUEL SYSTEMS)

## 28. Fuel Sub Level Sensor

### A: REMOVAL

#### WARNING:

- Place "NO FIRE" signs near the working area.
- Be careful not to spill fuel on the floor.
- During work procedures, if fuel tank is more than 3/4 full, be careful because fuel may spill.

- 1) Drain fuel from fuel tank. <Ref. to FU(H4SO U5)-53, DRAINING FUEL, OPERATION, Fuel.>
- 2) Raise rear seat and turn floor mat up. (Wagon model)
- 3) Remove rear seat. (Sedan model)
- 4) Remove service hole cover.

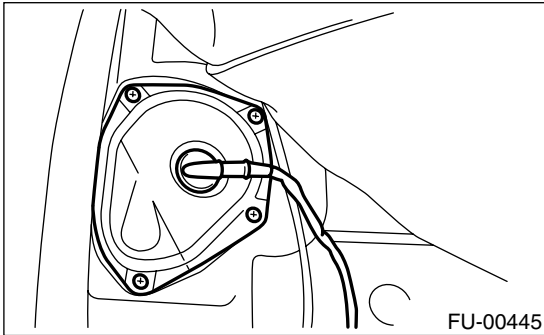

- 5) Disconnect connector from fuel sub level sensor.

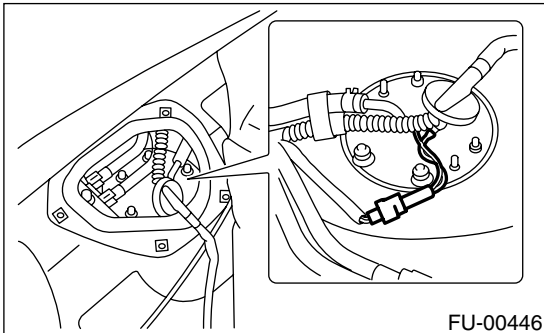

- 6) Disconnect fuel jet pump hose.

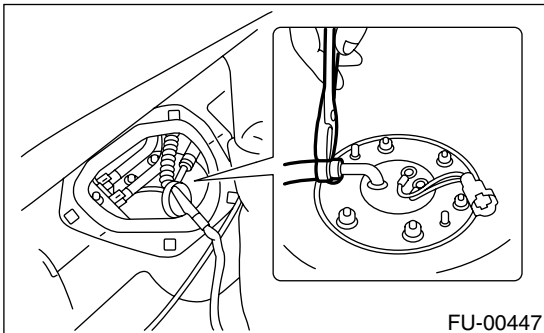

- 7) Remove bolts which install fuel sub level sensor on fuel tank.

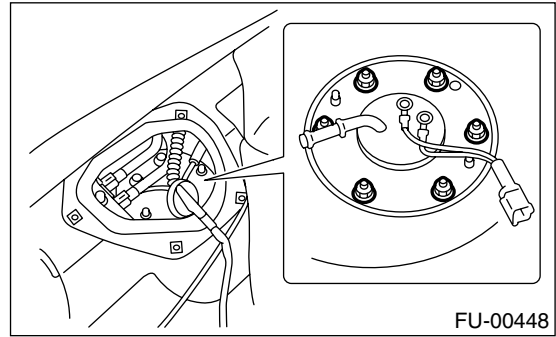

- 8) Remove fuel sub level sensor.

### B: INSTALLATION

Install in the reverse order of removal.

#### Tightening torque:

**4.4 N·m (0.45 kgf·m, 3.3 ft·lb)**

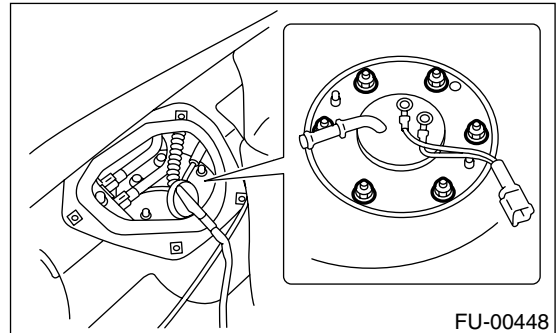

# FUEL FILTER

FUEL INJECTION (FUEL SYSTEMS)

## 29. Fuel Filter

### A: REMOVAL

#### WARNING:

- Place “NO FIRE” signs near the working area.
- Be careful not to spill fuel on the floor.

#### NOTE:

The fuel filter is built in fuel pump assembly.

- 1) Release the fuel pressure. <Ref. to FU(H4SO U5)-53, RELEASING OF FUEL PRESSURE, OPERATION, Fuel.>
- 2) Remove the fuel pump assembly. <Ref. to FU(H4SO U5)-70, REMOVAL, Fuel Pump.>
- 3) Disconnect the ground cable from filter holder.

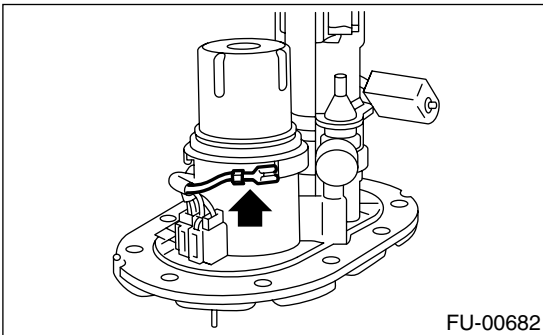

- 4) Remove the filter holder by turning it to the left from the body pawls, and then take out the filter.

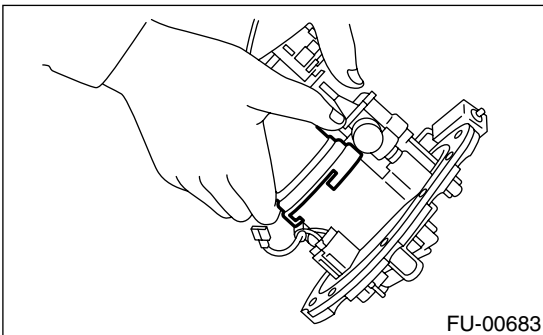

### B: INSTALLATION

#### NOTE:

- If the fuel hoses are damaged at the connecting portion, replace it with a new one.
- If the clamps are badly damaged, replace with new ones.
- Replace the o-ring with new ones.

- 1) Set the O-ring on the filter holder, and then install by turning to the right.

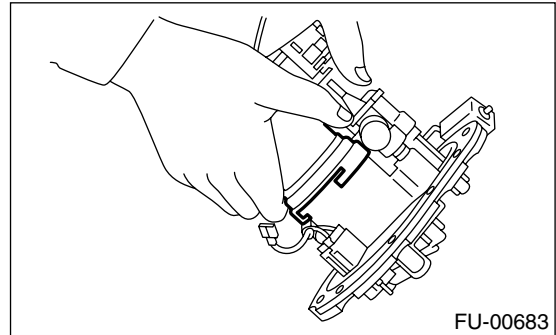

- 2) Connect the ground cable to filter holder.

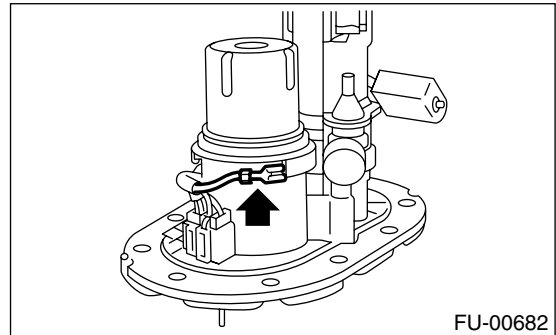

- 3) Install the fuel pump assembly. <Ref. to FU(H4SO U5)-70, INSTALLATION, Fuel Pump.>

### C: INSPECTION

- 1) Check the inside of fuel filter for dirt and water sediment.
- 2) If it is clogged, or if replacement interval has been reached, replace it.

## 30. Fuel Cut Valve

### A: REMOVAL

- 1) Remove fuel tank. <Ref. to FU(H4SO U5)-55, REMOVAL, Fuel Tank.>
- 2) Move clip and disconnect evaporation hose from fuel cut valve.

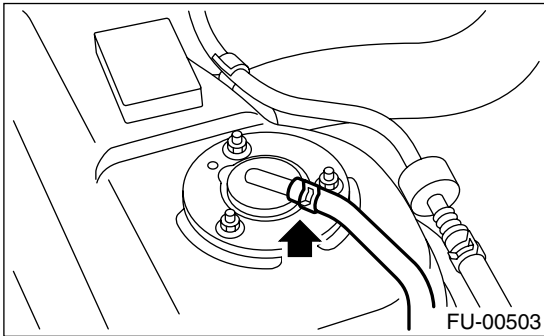

- 3) Remove bolts which install fuel cut valve.

### B: INSTALLATION

Install in the reverse order of removal.

#### **Tightening torque:**

**4.4 N·m (0.45 kgf·m, 3.3 ft-lb)**

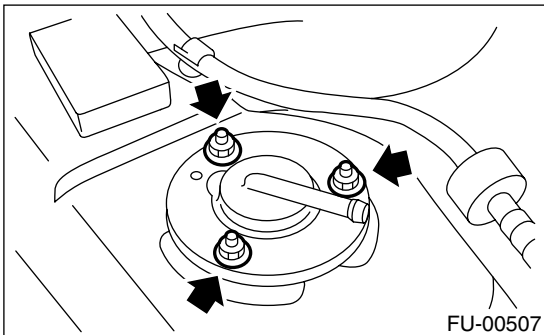

# FUEL DAMPER VALVE

FUEL INJECTION (FUEL SYSTEMS)

---

## 31. Fuel Damper Valve

### A: REMOVAL

- 1) Release the fuel pressure. <Ref. to FU(H4SO U5)-53, RELEASING OF FUEL PRESSURE, OPERATION, Fuel.>
- 2) Remove the fuel damper valve from the fuel delivery line and return line.

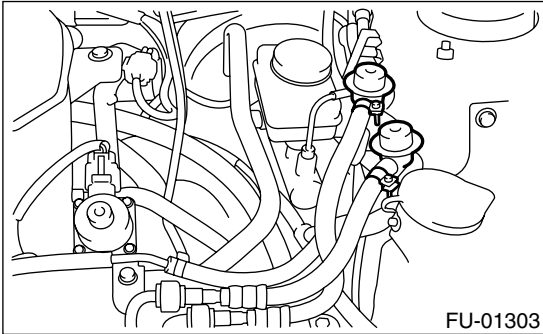

### B: INSTALLATION

Install in the reverse order of removal.

#### *Tightening torque:*

**1.5 N·m (0.15 kgf-m, 1.1 ft-lb)**

# FUEL DELIVERY, RETURN AND EVAPORATION LINES

FUEL INJECTION (FUEL SYSTEMS)

## 32. Fuel Delivery, Return and Evaporation Lines

### A: REMOVAL

- 1) Set vehicle on the lift.
- 2) Release fuel pressure. <Ref. to FU(H4SO U5)-53, RELEASING OF FUEL PRESSURE, OPERATION, Fuel.>
- 3) Open fuel filler flap lid and remove fuel filler cap.

- 4) Remove fuel tank. <Ref. to FU(H4SO U5)-55, REMOVAL, Fuel Tank.>
- 5) Remove fuel filler pipe. <Ref. to FU(H4SO U5)-63, REMOVAL, Fuel Filler Pipe.>
- 6) Remove floor mat. <Ref. to EI-60, REMOVAL, Floor Mat.>
- 7) Remove fuel delivery pipes and hoses, fuel return pipes and hoses, evaporation pipes and hoses.

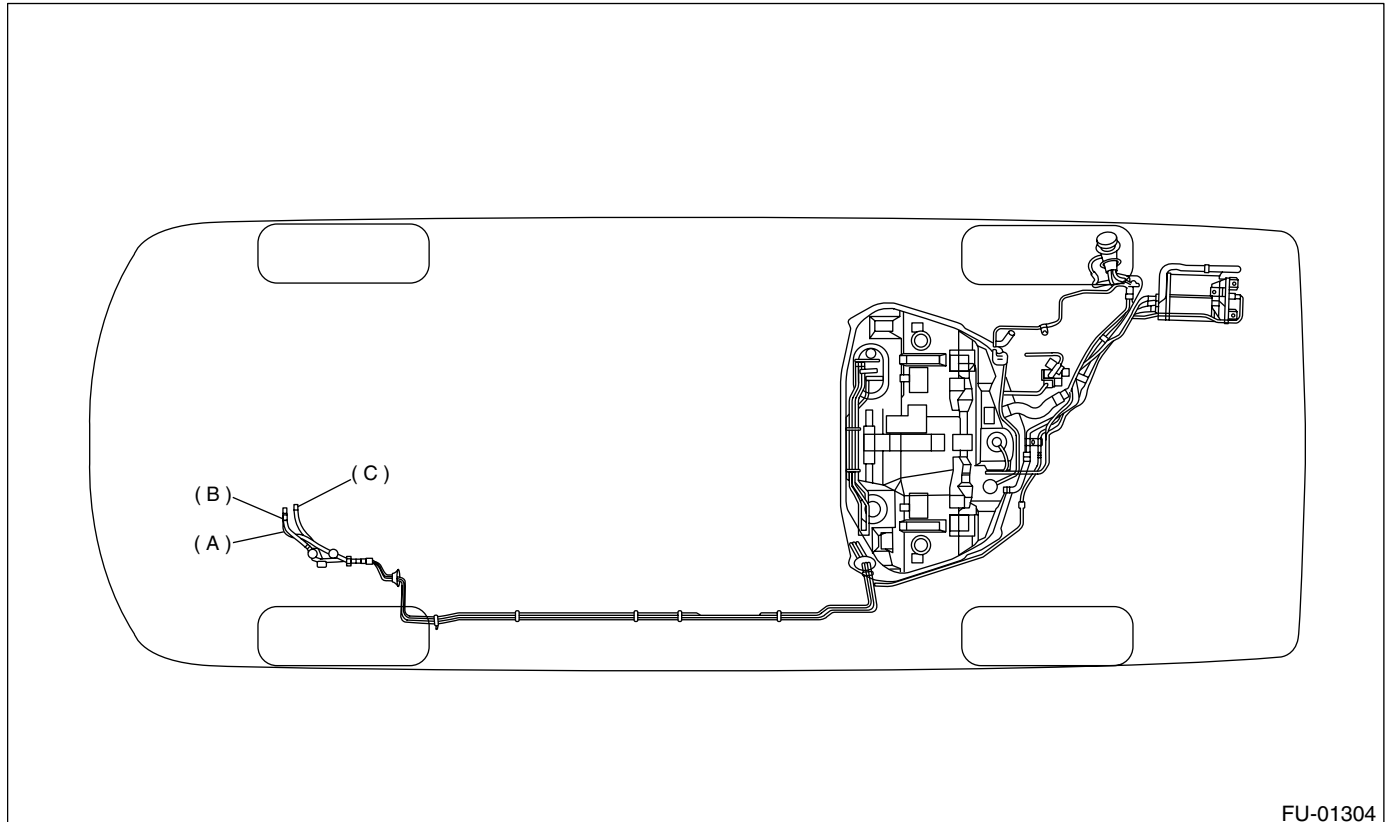

FU-01304

(A) Fuel delivery line

(B) Fuel return line

(C) Evaporation line

# FUEL DELIVERY, RETURN AND EVAPORATION LINES

## FUEL INJECTION (FUEL SYSTEMS)

8) In engine room, detach fuel delivery hoses, return hoses and evaporation hose.

- (1) Separate quick connector of fuel delivery line and return line by pushing the ST in the direction of the arrow. Separate quick connector of fuel delivery line and return line by pushing in the direction of the arrow using an ST.

ST 42099AE000 CONNECTOR REMOVER

- (2) Remove clip, and separate evaporation hose from pipe.

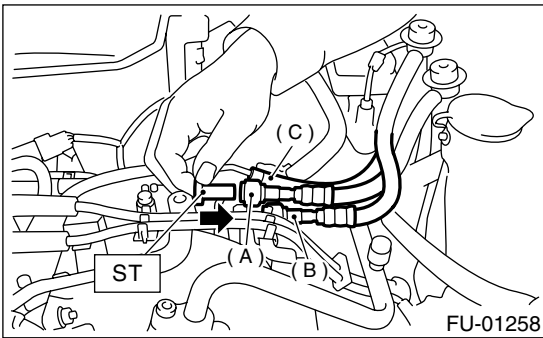

- (A) Fuel delivery hose
- (B) Return hose
- (C) Evaporation hose

9) Separate quick connector on fuel delivery and return line.

- (1) Clean pipe and connector, if they are covered with dust.
- (2) Cover pipe and connector with vinyl bag to prevent scratch and contamination.

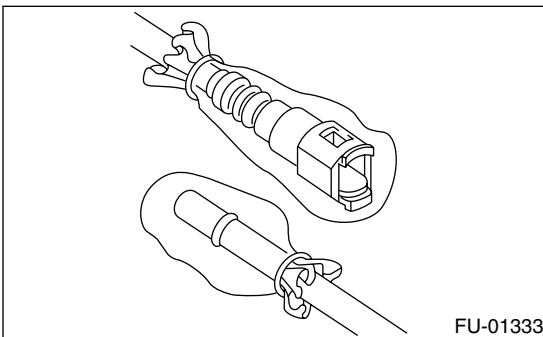

- (3) Hold connector (A) and push retainer (B) down.
- (4) Pull out connector (A) from retainer (B).

**CAUTION:**  
Replace retainer with new ones.

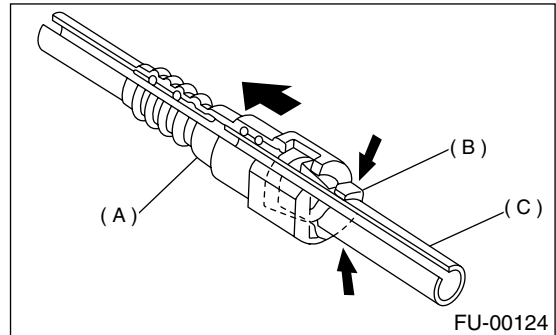

- (A) Connector
- (B) Retainer
- (C) Pipe

## B: INSTALLATION

1) Connect quick connector on fuel delivery and return line.

**CAUTION:**

- Always use a new retainer.
- Make sure that the connected portion is not damaged or has dust. If necessary, clean seal surface (A) of pipe.

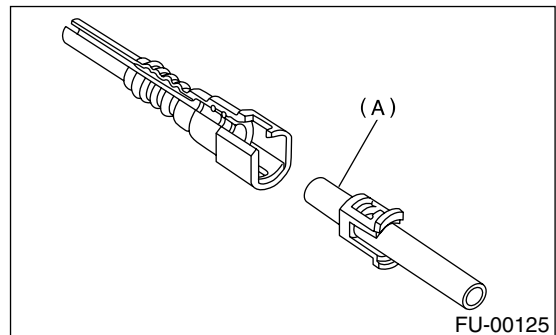

- (1) Set new retainer (B) to connector (A).
- (2) Push pipe into connector completely.

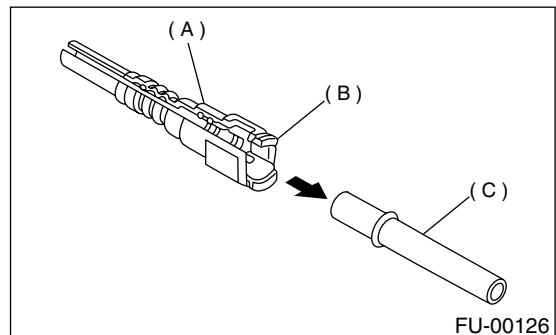

- (A) Connector
- (B) Retainer
- (C) Pipe

# FUEL DELIVERY, RETURN AND EVAPORATION LINES

FUEL INJECTION (FUEL SYSTEMS)

## CAUTION:

- Pull the connector to ensure it is connected securely.
- Ensure the two retainer pawls are engaged in their mating positions in the connector.
- Be sure to inspect hoses and their connections for any leakage of fuel.

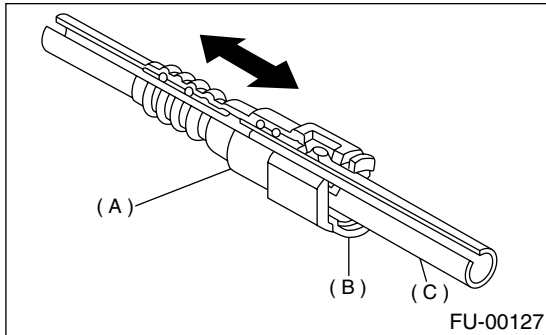

- (A) Connector
- (B) Retainer
- (C) Pipe

2) Connect fuel delivery hose to pipe with an overlap of 20 to 25 mm (0.79 to 0.98 in).

Type A: When insertion length is specified.

Type B: When insertion length is not specified.

$$\varnothing : 2.5 \pm 1.5 \text{ mm } (0.098 \pm 0.059 \text{ in})$$

$$L : 22.5 \pm 2.5 \text{ mm } (0.886 \pm 0.098 \text{ in})$$

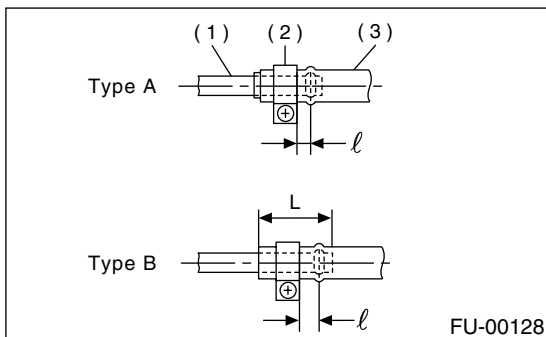

- (1) Pipe
- (2) Clamp
- (3) Hose

3) Connect evaporation hose to pipe by approx. 15 mm (0.59 in) from hose end.

$$L = 17.5 \pm 2.5 \text{ mm } (0.689 \pm 0.098 \text{ in})$$

## CAUTION:

Be sure to inspect hoses and their connections for any leakage of fuel.

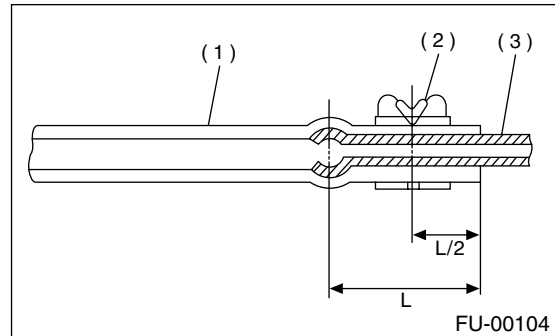

- (1) Hose
- (2) Clip
- (3) Pipe

## C: INSPECTION

1) Make sure that there are no cracks on the fuel pipes and fuel hoses.

2) Make sure that the fuel pipe and fuel hose connections are tight.

# FUEL SYSTEM TROUBLE IN GENERAL

## FUEL INJECTION (FUEL SYSTEMS)

### 33. Fuel System Trouble in General

#### A: INSPECTION

Trouble and possible cause		Corrective action
<b>1. Insufficient fuel supply to the injector</b>		
1)	Fuel pump will not operate.	
	○ Defective terminal contact.	Inspect connections, especially ground, and tighten securely.
	○ Trouble in electromagnetic or electronic circuit parts.	Replace fuel pump.
2)	Lowering of fuel pump function.	Replace fuel pump.
3)	Clogged dust or water in the fuel filter.	Replace fuel filter, clean or replace fuel tank.
4)	Clogged or bent fuel pipe or hose.	Clean, correct or replace fuel pipe or hose.
5)	Air is mixed in the fuel system.	Inspect or retighten each connection part.
6)	Clogged or bent breather tube or pipe.	Clean, correct or replace air breather tube or pipe.
7)	Damaged diaphragm of pressure regulator.	Replace.
<b>2. Leakage or blow out fuel</b>		
1)	Loosened joints of the fuel pipe.	Retightening.
2)	Cracked fuel pipe, hose and fuel tank.	Replace.
3)	Defective welding part on the fuel tank.	Replace.
4)	Defective drain packing of the fuel tank.	Replace.
5)	Clogged or bent air breather tube or air vent tube.	Clean, correct or replace air breather tube or air vent tube.
<b>3. Gasoline smell inside of compartment</b>		
1)	Loose joints at air breather tube, air vent tube and fuel filler pipe.	Retightening.
2)	Defective packing air tightness on the fuel saucer.	Correct or replace packing.
3)	Cracked fuel separator.	Replace separator.
4)	Inoperative fuel pump modulator or circuit.	Replace.
<b>4. Defective fuel level indicator</b>		
1)	Defective operation of fuel level sensor.	Replace.
<b>5. Noise</b>		
1)	Large operation noise or vibration of fuel pump.	Replace.

**NOTE:**

- When the vehicle is left unattended for an extended period of time, water may accumulate in the fuel tank. To prevent water condensation.

- (1) Top off the fuel tank or drain the fuel completely.
- (2) Drain water condensation from the fuel filter.

- Refilling the fuel tank.

Refill the fuel tank while there is still some fuel left in the tank.

- Protecting the fuel system against freezing and water condensation.

- (1) Cold areas

In snow-covered areas, mountainous areas, skiing areas, etc. where ambient temperatures drop below 0°C (32°F) throughout the winter season, use an anti-freeze solution in the fuel tank. Refueling will also complement the effect of anti-freeze solution each time the fuel level drops to about one-half. After the winter season, drain water which may have accumulated in the fuel filter and fuel tank in the manner same as that described under damaged areas below.

- (2) Damaged areas

If water accumulated in the fuel filter, drain water from both the fuel filter and fuel tank or use a water removing agent (or anti-freeze solution) in the fuel tank.

- Observe the instructions, notes, etc., indicated on the label affixed to the anti-freeze solution (water removing agent) container before use.



# FUEL SYSTEM TROUBLE IN GENERAL

FUEL INJECTION (FUEL SYSTEMS)

---

MEMO:

# **FUEL SYSTEM TROUBLE IN GENERAL**

FUEL INJECTION (FUEL SYSTEMS)

---