

INTAKE (INDUCTION)

IN(H4SO U5)

	Page
1. General Description	2
2. Air Cleaner Element	4
3. Air Cleaner Case	5
4. Air Intake Chamber	6
5. Air Intake Duct.....	7
6. Resonator Chamber	8

GENERAL DESCRIPTION

INTAKE (INDUCTION)

1. General Description

A: COMPONENT

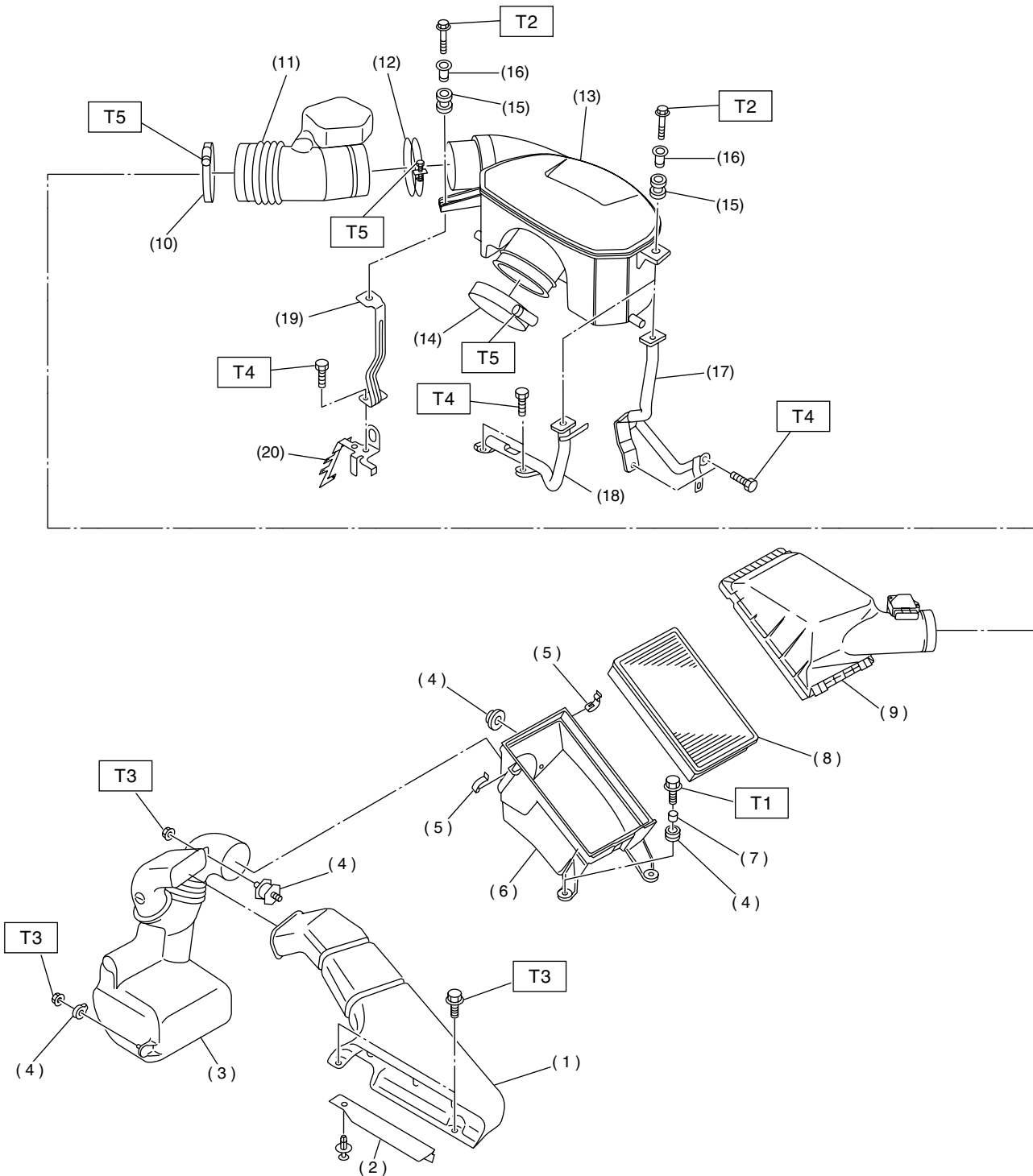

IN-00240

IN(H4SO U5)-2

GENERAL DESCRIPTION

INTAKE (INDUCTION)

(1) Air intake duct	(11) Air intake boot	(19) Air intake chamber stay RH
(2) Plate	(12) Clamp	(20) Engine harness bracket
(3) Resonator chamber	(13) Air intake chamber	
(4) Cushion	(14) Clamp	
(5) Clip	(15) Bushing	
(6) Air cleaner lower case	(16) Spacer	
(7) Spacer	(17) Air intake chamber stay LH (MT models)	
(8) Air cleaner element	(18) Air intake chamber stay LH (AT models)	
(9) Air cleaner upper cover		
(10) Clamp		

Tightening torque: N·m (kgf-m, ft-lb)

T1: 33 (3.4, 24.6)

T2: 6.5 (0.66, 4.8)

T3: 7.5 (0.76, 5.5)

T4: 16 (1.6, 11.6)

T5: 3 (0.3, 2.2)

B: CAUTION

- Wear working clothing, including a cap, protective goggles, and protective shoes during operation.
- Remove contamination including dirt and corrosion before removal, installation or disassembly.
- Keep the disassembled parts in order and protect them from dust or dirt.
- Before removal, installation or disassembly, be sure to clarify the failure. Avoid unnecessary removal, installation, disassembly, and replacement.
- Be careful not to burn your hands, because each part on the vehicle is hot after running.
- Be sure to tighten fasteners including bolts and nuts to the specified torque.
- Place shop jacks or safety stands at the specified points.
- Before disconnecting electrical connectors of sensor or units, be sure to disconnect the ground cable from battery.

AIR CLEANER ELEMENT

INTAKE (INDUCTION)

2. Air Cleaner Element

A: REMOVAL

- 1) Disconnect ground cable from battery.

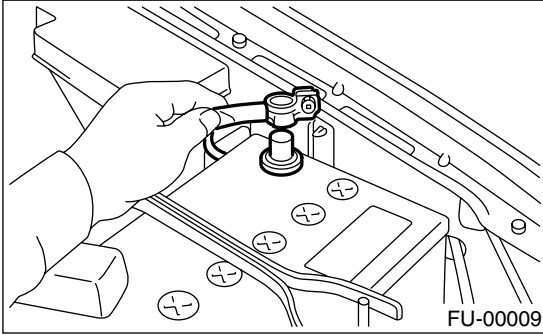

- 2) Disconnect connector from air flow sensor.

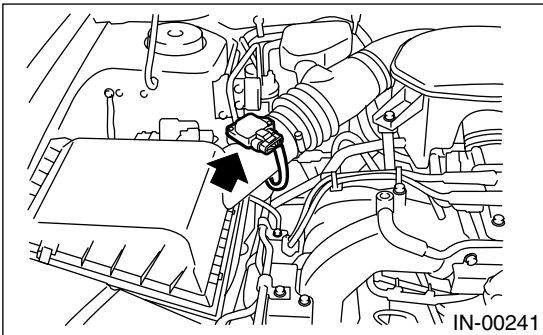

- 3) Remove the clip (A) above the air cleaner case.

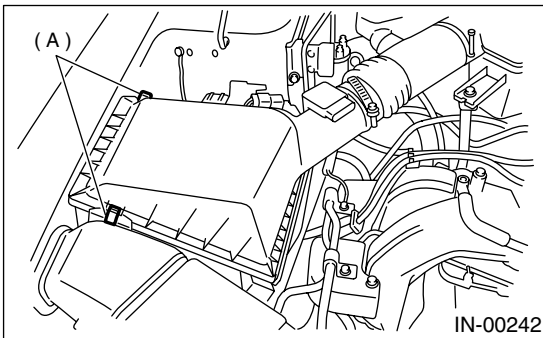

- 4) Raise air cleaner upper cover and remove air cleaner element.

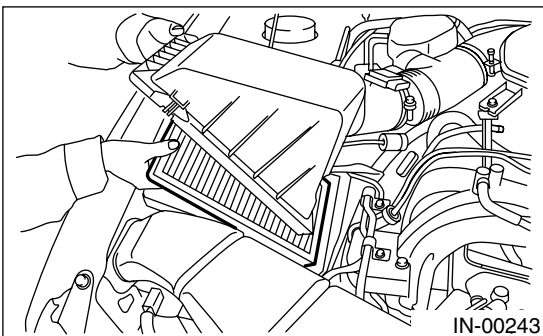

B: INSTALLATION

Install in the reverse order of removal.

NOTE:

Before installing air cleaner upper cover, align protruding portions with holes of air cleaner lower case, then secure upper cover to lower case.

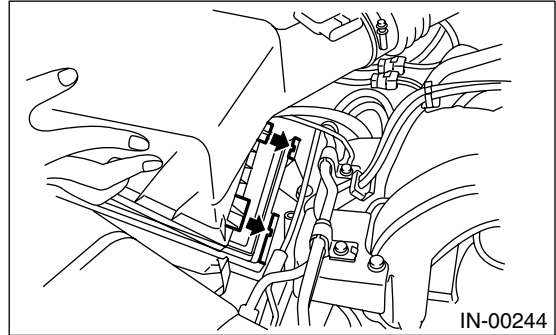

C: INSPECTION

Replace if excessively damaged or dirty.

3. Air Cleaner Case

A: REMOVAL

- 1) Remove air intake duct. <Ref. to IN(H4SO U5)-7, REMOVAL, Air Intake Duct.>
- 2) Remove air cleaner element. <Ref. to IN(H4SO U5)-4, REMOVAL, Air Cleaner Element.>
- 3) Remove bolt which installs air cleaner case to body.

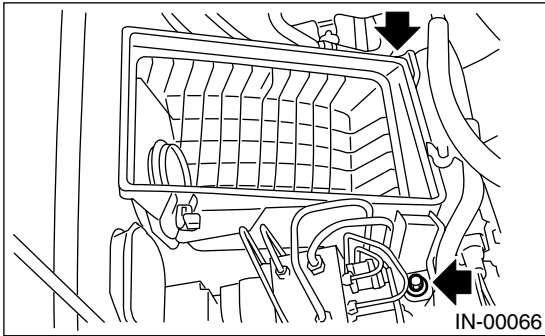

- 4) Remove the air cleaner case.

B: INSTALLATION

Install in the reverse order of removal.

Tightening torque:

33 N·m (3.4 kgf-m, 24.6 ft-lb)

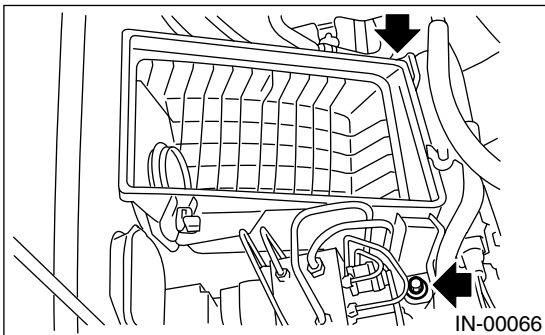

C: INSPECTION

Check for cracks and loose connections.

AIR INTAKE CHAMBER

INTAKE (INDUCTION)

4. Air Intake Chamber

A: REMOVAL

- 1) Loosen clamp (A) which connects air intake chamber and throttle body.
- 2) Loosen clamp (B) which connects air intake boot and air intake chamber.
- 3) Remove bolt (C) which secures air intake chamber to stay.

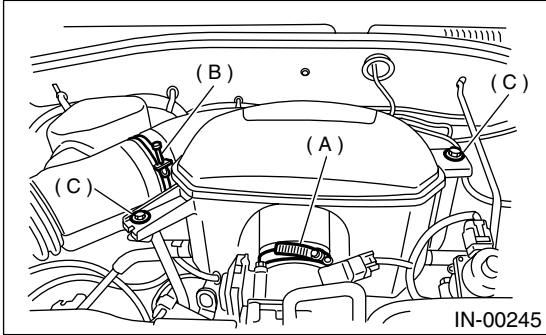

- 4) Disconnect blow-by hoses (2 places) and then, remove air intake chamber.

B: INSTALLATION

Install in the reverse order of removal.

Tightening torque:

6.5 N·m (0.66 kgf-m, 4.8 ft-lb)

C: INSPECTION

- 1) Check for cracks and loose connections.
- 2) Make sure that no foreign objects are mixed in the air intake chamber.

5. Air Intake Duct

A: REMOVAL

1) Remove bolts which install air intake duct on the front side of body.

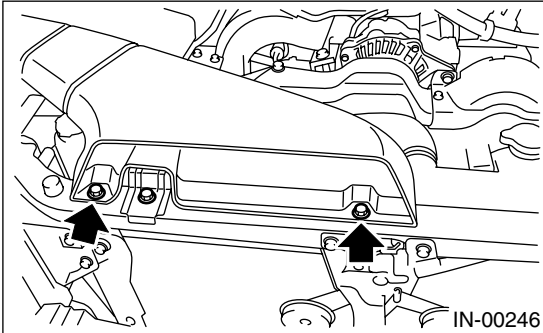

B: INSTALLATION

Install in the reverse order of removal.

Tightening torque:

7.5 N·m (0.76 kgf-m, 5.5 ft-lb)

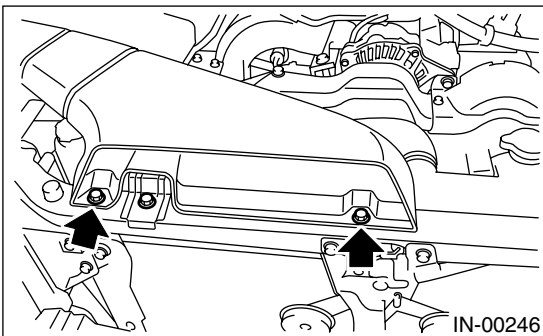

C: INSPECTION

Check for cracks and loose connections. Make sure that no foreign objects are mixed in the air intake duct.

6. Resonator Chamber

A: REMOVAL

- 1) Set vehicle on a lift.
- 2) Remove air intake duct. <Ref. to IN(H4SO U5)-7, REMOVAL, Air Intake Duct.>
- 3) Remove air cleaner case. <Ref. to IN(H4SO U5)-5, REMOVAL, Air Cleaner Case.>
- 4) Remove the resonator chamber mounting bolt on the right of engine compartment.

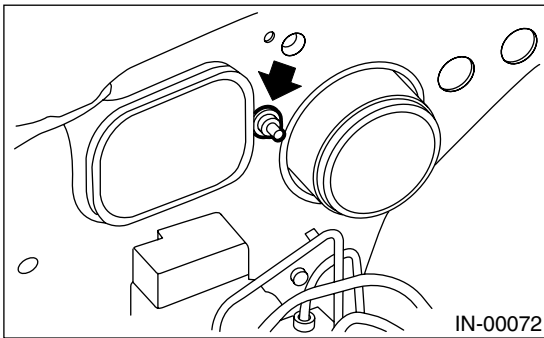

- 5) Remove the front right tire, and lift the vehicle.
- 6) Remove front mudguard RH.
- 7) Remove the resonator chamber (A) from the inside front fender.

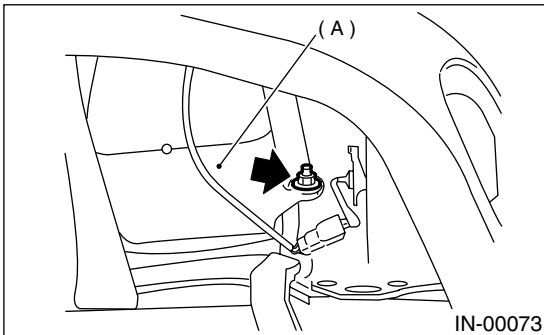

B: INSTALLATION

Install in the reverse order of removal.

C: INSPECTION

Check for cracks and loose connections. Make sure that no foreign objects are mixed in the resonator chamber.