

FUEL INJECTION (FUEL SYSTEMS)

FU(H4DOTC)

	Page
1. General Description	2
2. Throttle Body	14
3. Intake Manifold.....	15
4. Engine Coolant Temperature Sensor.....	27
5. Crankshaft Position Sensor.....	28
6. Camshaft Position Sensor.....	29
7. Knock Sensor	30
8. Mass Air Flow and Intake Air Temperature Sensor	31
9. Manifold Absolute Pressure Sensor.....	32
10. Fuel Injector	33
11. Tumble Generator Valve Assembly	34
12. Tumble Generator Valve Actuator.....	35
13. Tumble Generator Valve Position Sensor.....	36
14. Wastegate Control Solenoid Valve	37
15. Front Oxygen (A/F) Sensor	38
16. Rear Oxygen Sensor.....	40
17. Exhaust Temperature Sensor	42
18. Engine Control Module (ECM)	43
19. Main Relay	44
20. Fuel Pump Relay.....	45
21. Electronic Control Throttle Relay	46
22. Fuel Pump Control Unit.....	47
23. Fuel	48
24. Fuel Tank	51
25. Fuel Filler Pipe	59
26. Fuel Pump.....	67
27. Fuel Level Sensor	70
28. Fuel Sub Level Sensor.....	71
29. Fuel Filter	72
30. Fuel Cut Valve.....	73
31. Fuel Damper Valve	74
32. Fuel Delivery, Return and Evaporation Lines.....	75
33. Fuel System Trouble in General	78

GENERAL DESCRIPTION

FUEL INJECTION (FUEL SYSTEMS)

1. General Description

A: SPECIFICATIONS

Fuel tank	Capacity	60 ℓ (15.9 US gal, 13.2 Imp gal)
	Location	Under rear seat
Fuel pump	Type	Impeller
	Shutoff discharge pressure	450 — 677 kPa (4.59 — 6.9 kg/cm ² , 65.27 — 98.2 psi)
	Discharge flow	More than 130 ℓ (34.3 US gal, 28.6 Imp gal)/h [12 V at 300 kPa (3.06 kg/cm ² , 43.5 psi)]
Fuel filter		Cartridge type

GENERAL DESCRIPTION

FUEL INJECTION (FUEL SYSTEMS)

MEMO:

GENERAL DESCRIPTION

FUEL INJECTION (FUEL SYSTEMS)

B: COMPONENT

1. INTAKE MANIFOLD

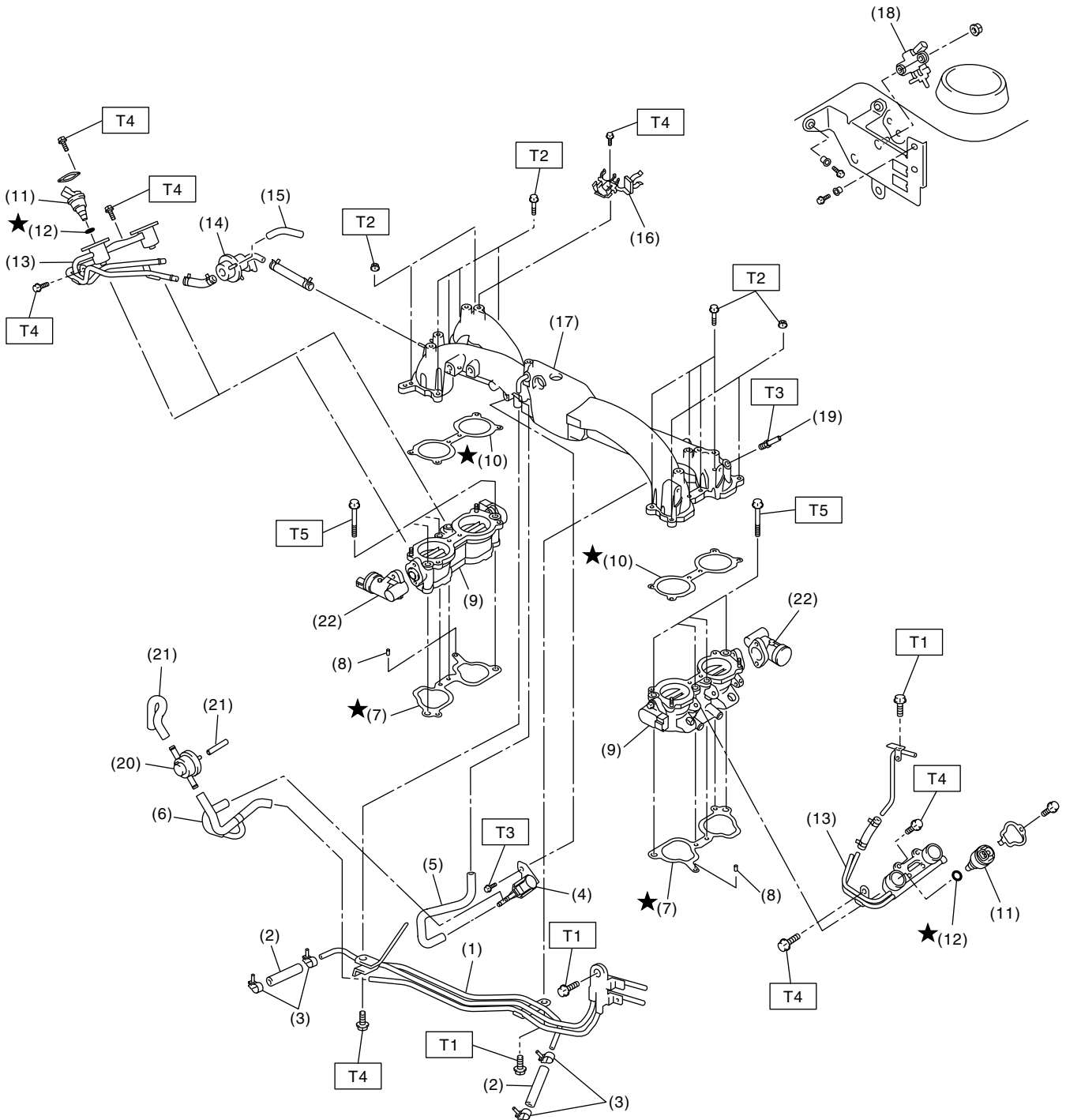

FU-02037

FU(H4DOTC)-4

GENERAL DESCRIPTION

FUEL INJECTION (FUEL SYSTEMS)

(1) Fuel pipe ASSY	(13) Fuel injector pipe	<i>Tightening torque: N-m (kgf-m, ft-lb)</i>
(2) Fuel hose	(14) Pressure regulator	<i>T1: 5 (0.5, 3.6)</i>
(3) Clip	(15) Pressure regulator hose	<i>T3: 8.25 (0.84, 6.1)</i>
(4) Purge control solenoid valve	(16) Blow-by hose stay	<i>T5: 17 (1.73, 12.5)</i>
(5) Vacuum hose	(17) Intake manifold	<i>T6: 19 (1.94, 13.7)</i>
(6) Vacuum control hose	(18) Wastegate control solenoid valve ASSY	<i>T7: 25 (2.5, 18.1)</i>
(7) Intake manifold gasket		
(8) Guide pin	(19) Nipple	
(9) Tumble generator valve ASSY	(20) Purge valve	
(10) Tumble generator valve gasket	(21) Purge hose	
(11) Fuel injector	(22) Tumble generator valve actuator	
(12) O-ring		

GENERAL DESCRIPTION

FUEL INJECTION (FUEL SYSTEMS)

2. AIR INTAKE SYSTEM

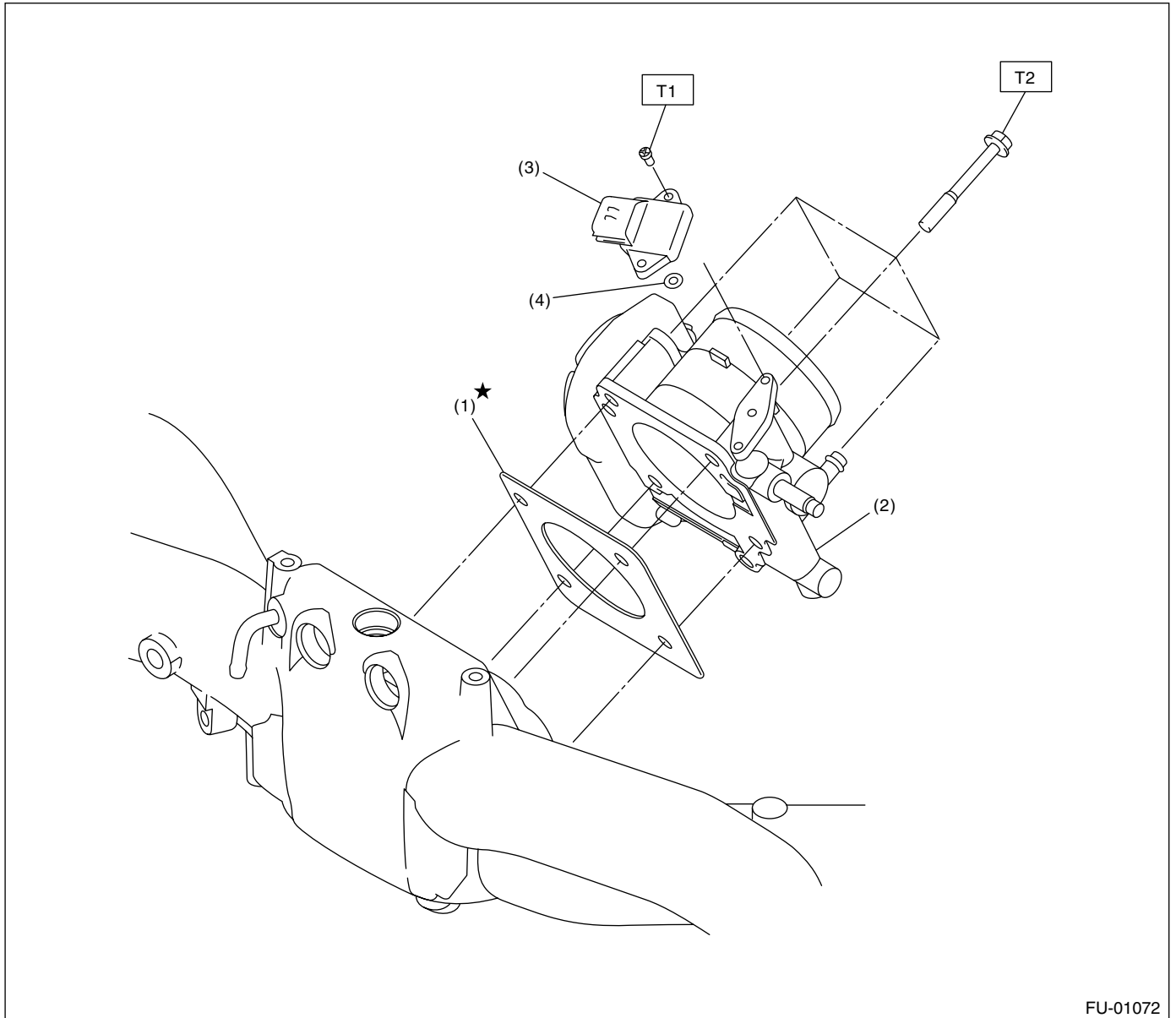

FU-01072

- (1) Gasket
- (2) Throttle body

- (3) Manifold absolute pressure sensor
- (4) O-ring

Tightening torque: N·m (kgf·m, ft·lb)

T1: 1.6 (0.16, 1.2)

T2: 8 (0.8, 5.8)

GENERAL DESCRIPTION

FUEL INJECTION (FUEL SYSTEMS)

3. CRANKSHAFT POSITION, CAMSHAFT POSITION AND KNOCK SENSORS

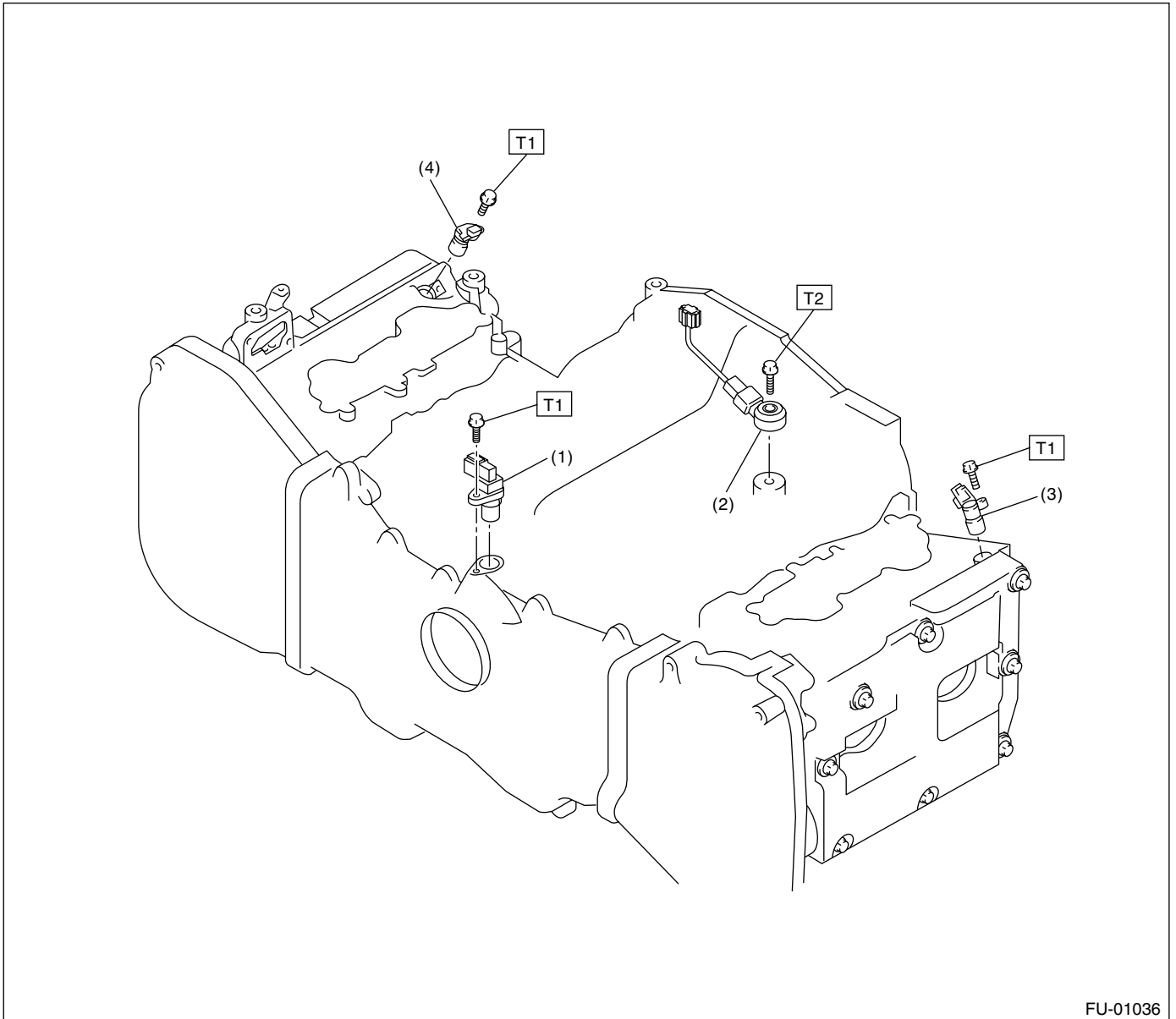

- (1) Crankshaft position sensor
- (2) Knock sensor

- (3) Camshaft position sensor LH
- (4) Camshaft position sensor RH

Tightening torque: N·m (kgf-m, ft-lb)

T1: 6.4 (0.65, 4.7)

T2: 24 (2.4, 17.4)

GENERAL DESCRIPTION

FUEL INJECTION (FUEL SYSTEMS)

4. FUEL TANK

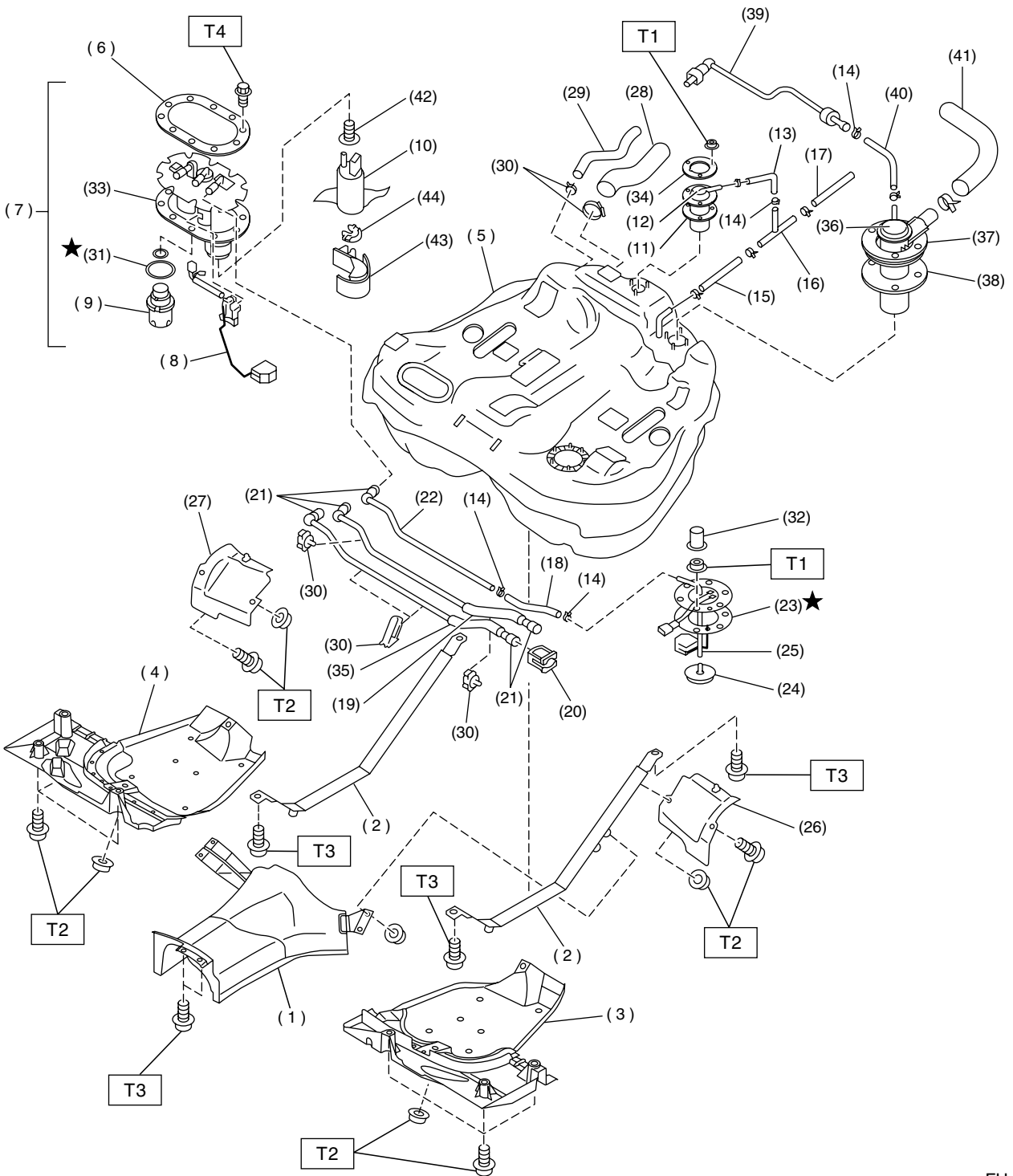

FU-02002

GENERAL DESCRIPTION

FUEL INJECTION (FUEL SYSTEMS)

(1) Heat sealed cover	(18) Jet pump hose	(35) Fuel delivery tube
(2) Fuel tank band	(19) Fuel return tube	(36) Vent valve
(3) Protector LH (Front)	(20) Retainer	(37) Vent valve plate
(4) Protector RH (Front)	(21) Quick connector	(38) Vent valve gasket
(5) Fuel tank	(22) Jet pump tube	(39) Evaporation tube
(6) Fuel pump plate	(23) Fuel sub level sensor gasket	(40) Evaporation hose D
(7) Fuel pump ASSY	(24) Jet pump filter	(41) Air vent hose
(8) Fuel level sensor	(25) Fuel sub level sensor	(42) Seal
(9) Fuel filter	(26) Protector LH (Rear)	(43) Fuel pump holder
(10) Fuel pump	(27) Protector RH (Rear)	(44) Grommet
(11) Fuel cut valve gasket	(28) Fuel filler hose	
(12) Fuel cut valve	(29) Fuel tank pressure sensor hose	
(13) Evaporation hose A	(30) Clamp	
(14) Clip	(31) Gasket	
(15) Evaporation hose C	(32) Cap	
(16) Joint pipe	(33) Gasket	
(17) Evaporation hose B	(34) Fuel cut valve plate	

Tightening torque: N-m (kgf-m, ft-lb)**T1: 4.4 (0.45, 3.3)****T2: 18 (1.8, 13.0)****T3: 33 (3.4, 25)****T4: 5.9 (0.6, 4.3)**

GENERAL DESCRIPTION

FUEL INJECTION (FUEL SYSTEMS)

5. Fuel Line

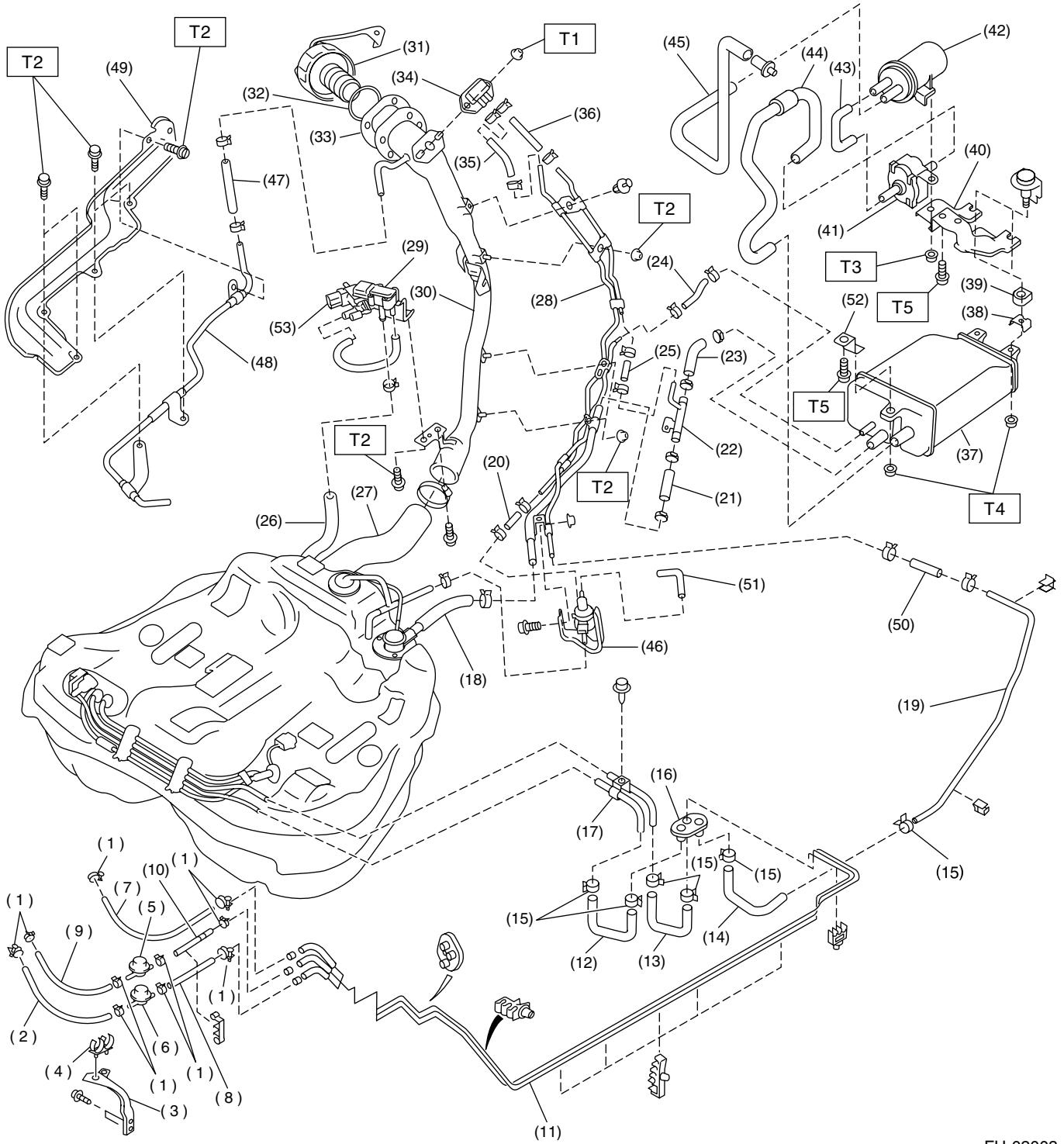

FU-02003

GENERAL DESCRIPTION

FUEL INJECTION (FUEL SYSTEMS)

- | | | |
|----------------------------|-------------------------------------|-------------------------------------------|
| (1) Clamp | (23) Evaporation hose I | (45) Drain filter hose B |
| (2) Fuel delivery hose A | (24) Evaporation hose J | (46) Pressure control solenoid valve |
| (3) Bracket | (25) Evaporation hose K | (47) Evaporation hose N |
| (4) Clamp | (26) Fuel tank pressure sensor hose | (48) Evaporation pipe C |
| (5) Fuel damper (return) | (27) Fuel filler hose | (49) Pipe protector |
| (6) Fuel damper (delivery) | (28) Evaporation pipe B | (50) Evaporation hose O |
| (7) Evaporation hose F | (29) Fuel tank pressure sensor | (51) Pressure control solenoid valve hose |
| (8) Fuel delivery hose B | (30) Fuel filler pipe | (52) Canister bracket (front) |
| (9) Fuel return hose A | (31) Fuel filler cap | (53) Fuel tank sensor control valve |
| (10) Fuel return hose B | (32) Ring B | |
| (11) Fuel pipe ASSY | (33) Packing | |
| (12) Fuel delivery hose C | (34) Shut valve | |
| (13) Fuel return hose C | (35) Evaporation hose L | |
| (14) Evaporation hose G | (36) Evaporation hose M | |
| (15) Clamp | (37) Canister | |
| (16) Grommet | (38) Canister lower bracket | |
| (17) Fuel pipe ASSY | (39) Cushion rubber | |
| (18) Air vent hose A | (40) Canister upper bracket | |
| (19) Evaporation pipe A | (41) Drain valve | |
| (20) Evaporation hose H | (42) Drain filter | |
| (21) Air vent hose B | (43) Drain filter hose A | |
| (22) Air vent pipe | (44) Drain valve hose | |

Tightening torque: N-m (kgf-m, ft-lb)**T1: 4.5 (0.46, 3.3)****T2: 7.5 (0.76, 5.5)****T3: 18 (1.8, 13.0)****T4: 23 (2.3, 16.6)****T5: 33 (3.4, 25)**

GENERAL DESCRIPTION

FUEL INJECTION (FUEL SYSTEMS)

6. Fuel Filler Pipe

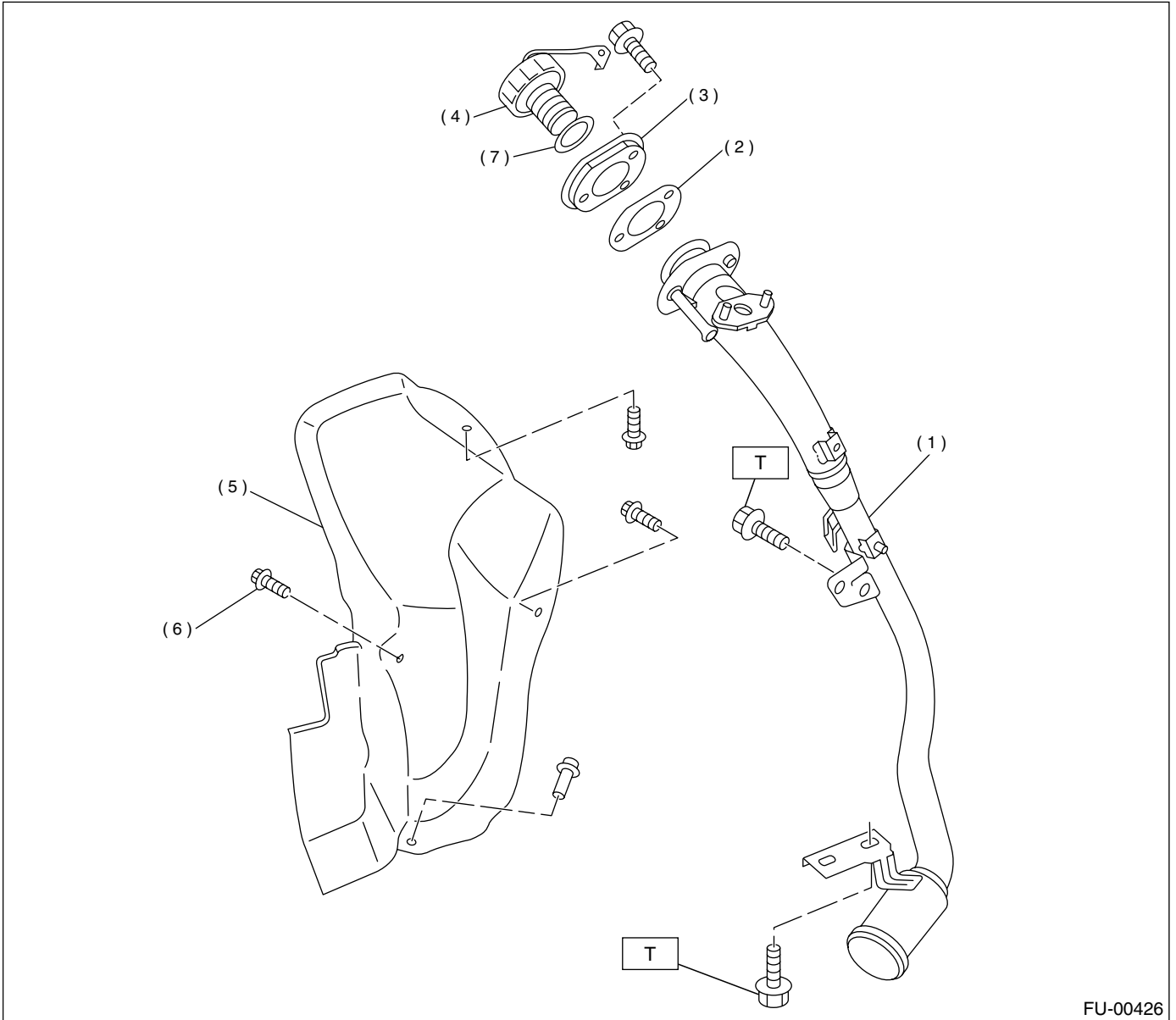

FU-00426

- | | |
|---------------------------|---------------------------|
| (1) Fuel filler pipe ASSY | (5) Filler pipe protector |
| (2) Filler pipe packing | (6) Clip |
| (3) Filler ring | (7) Ring B |
| (4) Filler cap | |

Tightening torque: N·m (kgf-m, ft-lb)

T: 7.5 (0.75, 5.4)

GENERAL DESCRIPTION



FUEL INJECTION (FUEL SYSTEMS)

C: CAUTION

- Wear working clothing, including a cap, protective goggles, and protective shoes during operation.
- Remove contamination including dirt and corrosion before removal, installation or disassembly.
- Keep the disassembled parts in order and protect them from dust or dirt.
- Before removal, installation or disassembly, be sure to clarify the failure. Avoid unnecessary removal, installation, disassembly, and replacement.

- Be careful not to burn your hands, because each part on the vehicle is hot after running.
- Be sure to tighten fasteners including bolts and nuts to the specified torque.
- Place shop jacks or safety stands at the specified points.
- Before disconnecting electrical connectors of sensors or units, be sure to disconnect negative terminal from battery.
- Place "NO FIRE" signs near the working area.
- Be careful not to spill fuel on the floor.

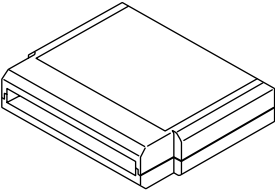
D: PREPARATION TOOL

ILLUSTRATION	TOOL NUMBER	DESCRIPTION	REMARKS
 <p>ST24082AA230</p>	<p>24082AA230 (New adopted tool)</p>	CARTRIDGE	Troubleshooting for electrical system.
 <p>ST22771AA030</p>	22771AA030	SELECT MONITOR KIT	Troubleshooting for electrical systems.

THROTTLE BODY

FUEL INJECTION (FUEL SYSTEMS)

2. Throttle Body

A: REMOVAL

1) Disconnect the ground cable from battery.

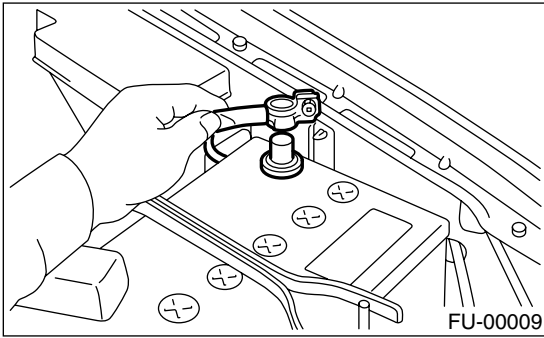

2) Remove the intercooler. <Ref. to IN(H4DOTC)-10, REMOVAL, Intercooler.>

3) Disconnect the connector from the throttle position sensor (A) and manifold absolute pressure sensor (B).

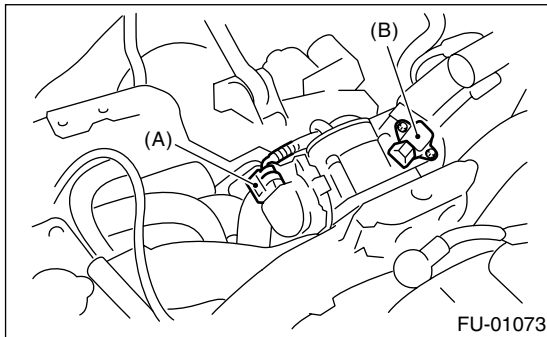

4) Disconnect the engine coolant hoses from the throttle body.

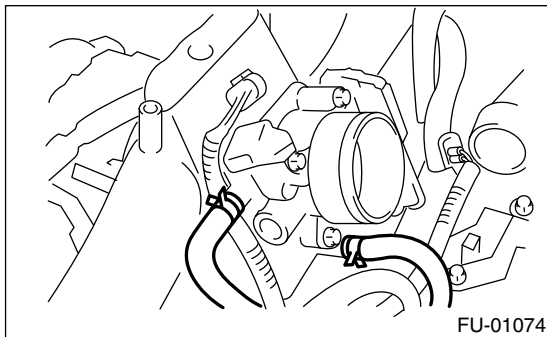

5) Remove the bolts which secure the throttle body to intake manifold.

B: INSTALLATION

Install in the reverse order of removal.

NOTE:

Always use a new gasket.

Tightening torque:

8 N·m (0.8 kgf-m, 5.8 ft-lb)

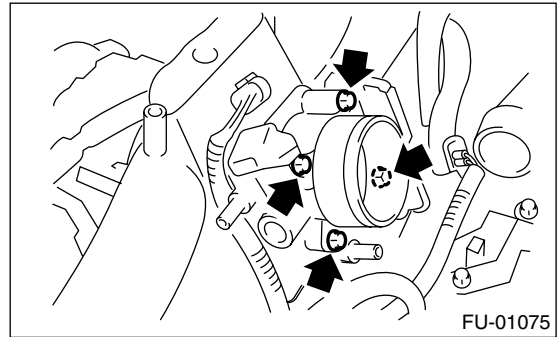

3. Intake Manifold

A: REMOVAL

- 1) Release the fuel pressure. <Ref. to FU(H4DOTC)-48, RELEASING OF FUEL PRESSURE, OPERATION, Fuel.>
- 2) Open the fuel filler lid and remove the fuel filler cap.
- 3) Disconnect the ground cable from battery.

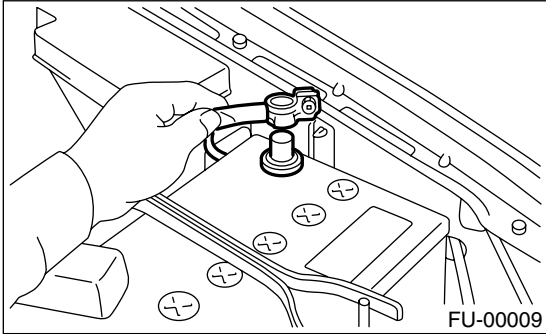

- 4) Lift up the vehicle.
- 5) Remove the under cover.
- 6) Drain the engine coolant about 3.0 ℓ (3.2 US qt, 2.6 Imp qt).

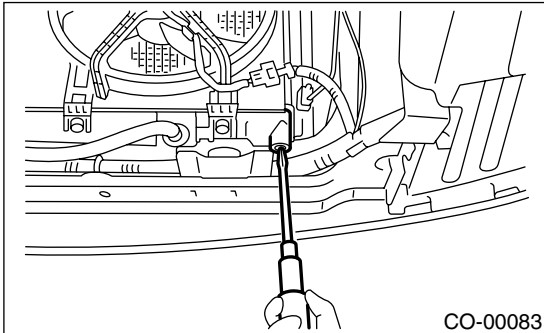

- 7) Remove the air cleaner upper cover and air intake boot. <Ref. to IN(H4DOTC)-7, REMOVAL, Air Cleaner.>
- 8) Remove the air cleaner element.
- 9) Remove the intercooler. <Ref. to IN(H4DOTC)-10, REMOVAL, Intercooler.>
- 10) Remove the coolant filler tank. <Ref. to CO(H4DOTC)-29, REMOVAL, Coolant Filler Tank.>
- 11) Remove the power steering pump.
 - (1) Remove the front side V-belt. <Ref. to ME(H4DOTC)-45, REMOVAL, V-belt.>

- (2) Disconnect the power steering switch connector.

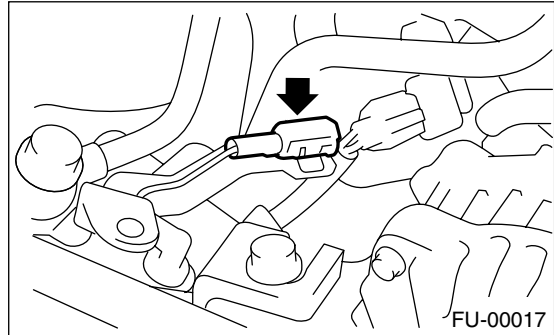

- (3) Remove the bolts which secure the power steering pipe brackets to the intake manifold.

NOTE:

Do not disconnect the power steering hose.

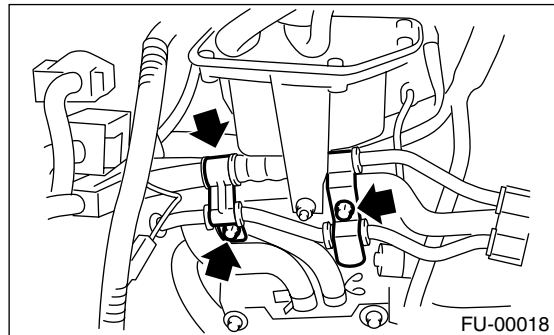

- (4) Remove the bolts which secure the power steering pump bracket.

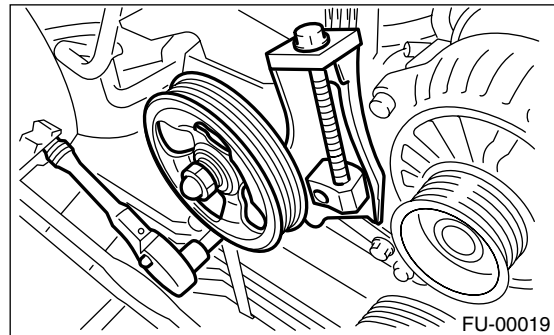

- (5) Remove the power steering tank from the bracket by pulling it upward.

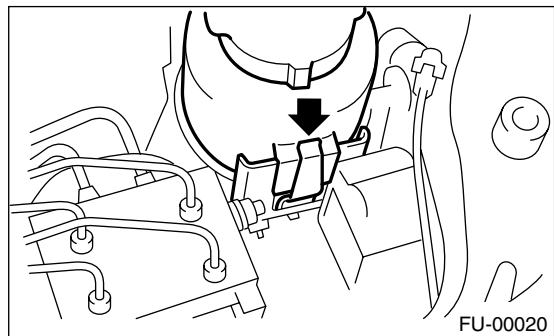

INTAKE MANIFOLD

FUEL INJECTION (FUEL SYSTEMS)

(6) Place the power steering pump on the right side wheel apron.

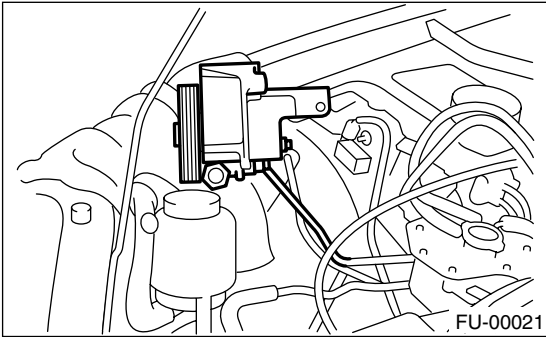

15) Disconnect the pressure hose from the intake duct.

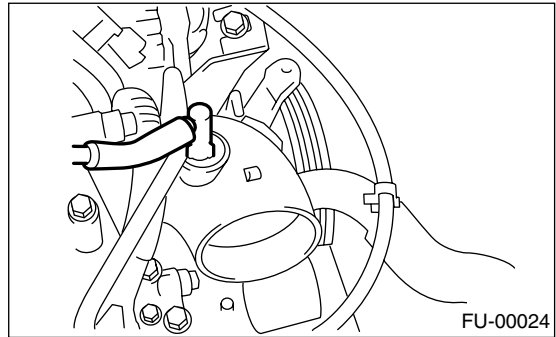

12) Disconnect the emission hose (A) and connector (B) from the PCV hose assembly.

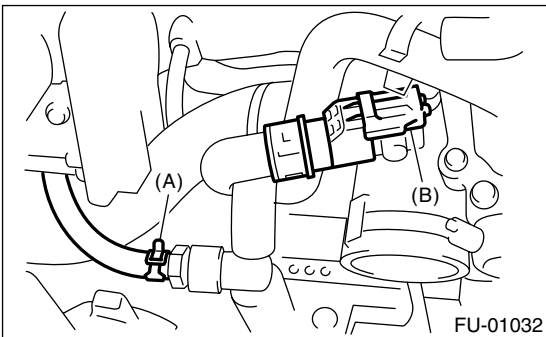

16) Disconnect the engine harness connectors from the bulkhead harness connectors.

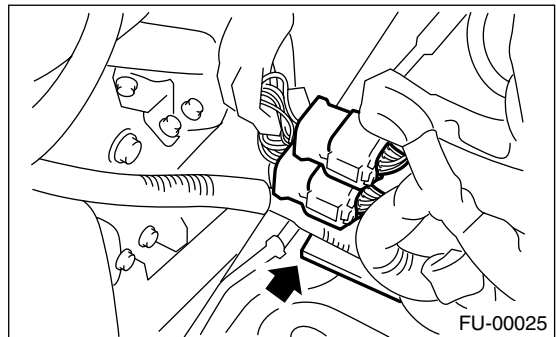

13) Disconnect the engine coolant hoses from the throttle body.

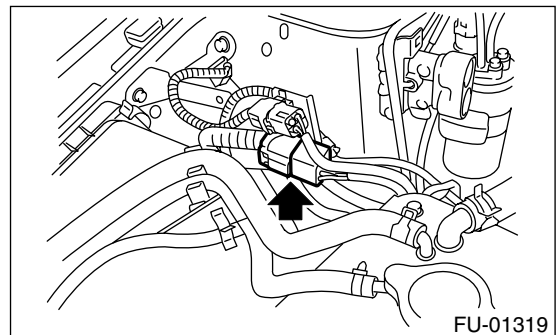
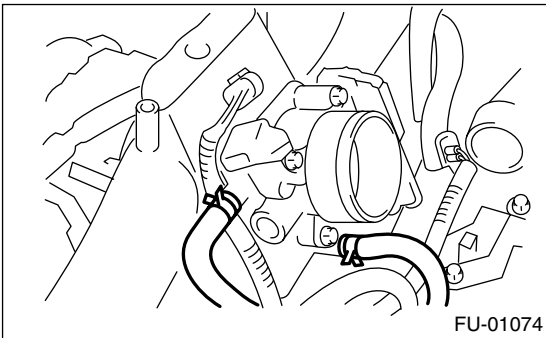

14) Disconnect the brake booster hose.

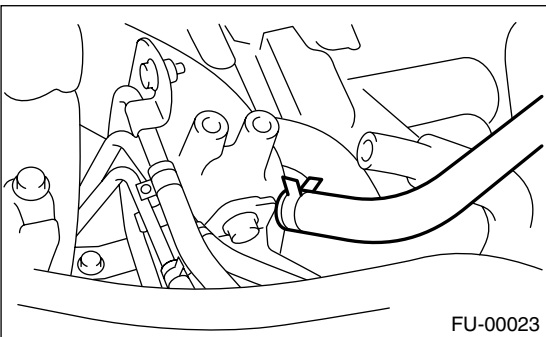

17) Disconnect the connectors from the engine coolant temperature sensor (A), oil pressure switch (B) and crankshaft position sensor (C).

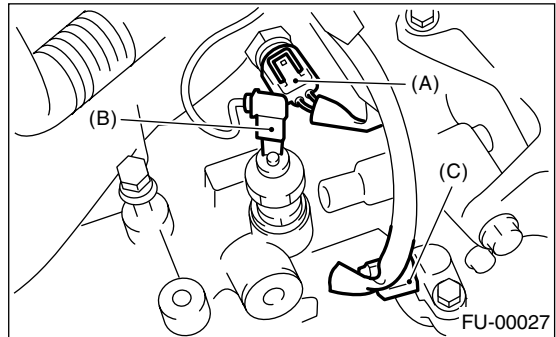

INTAKE MANIFOLD

FUEL INJECTION (FUEL SYSTEMS)

18) Disconnect the knock sensor connector.

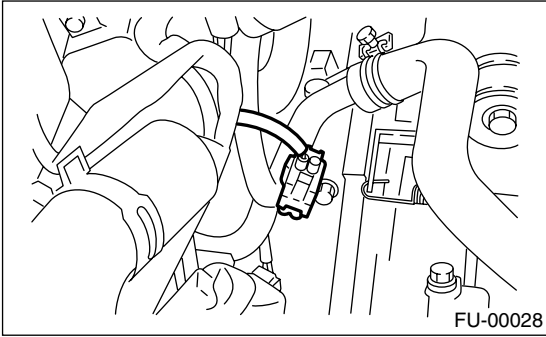

19) Disconnect the connector from the camshaft position sensor.

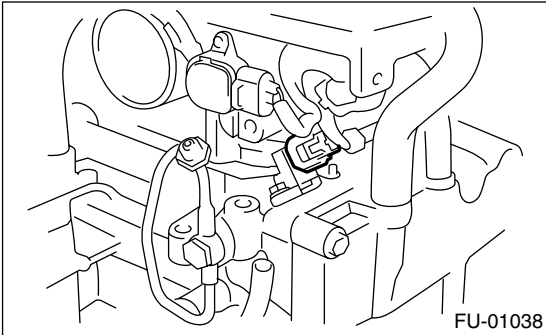

20) Disconnect the connector from the ignition coil.

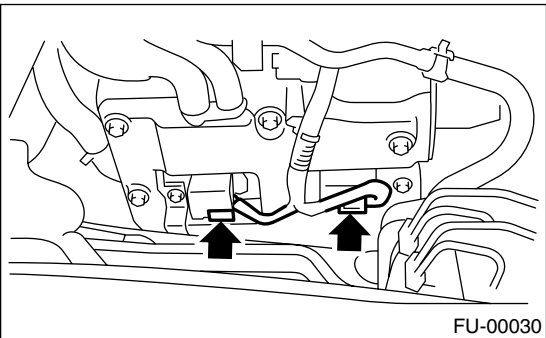

21) Disconnect the engine harness fixed by clip (A) from the bracket.

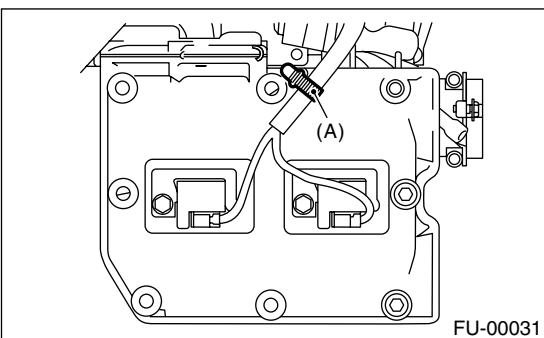

22) Disconnect the fuel delivery hose, return hose and evaporation hose.

CAUTION:

- Do not spill fuel.

- Catch fuel from hoses in a container or cloth.

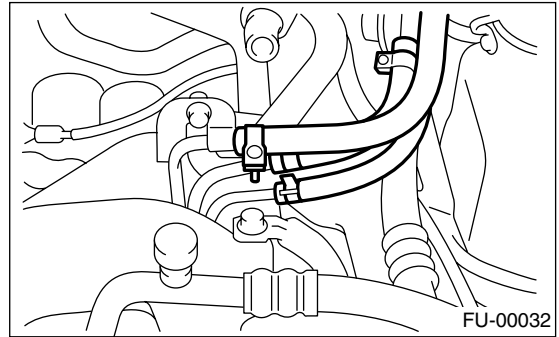

23) Remove the bolts which secure the intake manifold to the cylinder heads.

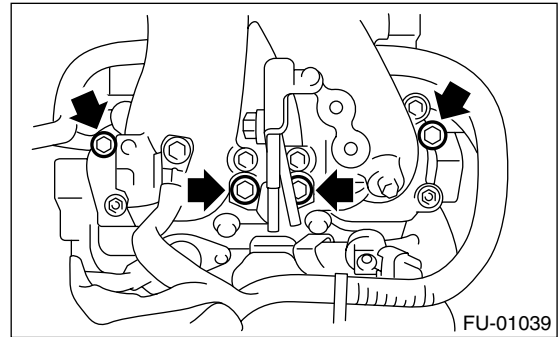

24) Remove the intake manifold.

B: INSTALLATION

1) Install the intake manifold onto cylinder heads.

NOTE:

Always use new gaskets.

Tightening torque:

25 N·m (2.5 kgf-m, 18.1 ft-lb)

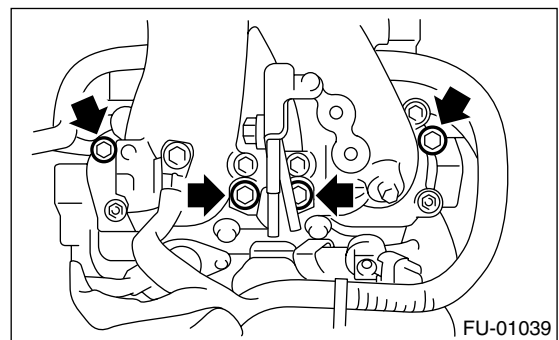

INTAKE MANIFOLD

FUEL INJECTION (FUEL SYSTEMS)

2) Connect the fuel delivery hose, return hose and evaporation hose.

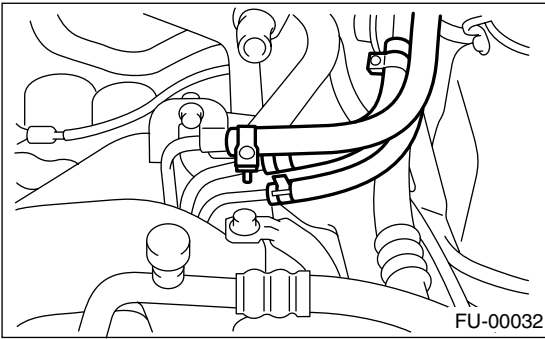

3) Connect the connector to the oil pressure switch (B), crankshaft position sensor (C) and engine coolant temperature sensor (A).

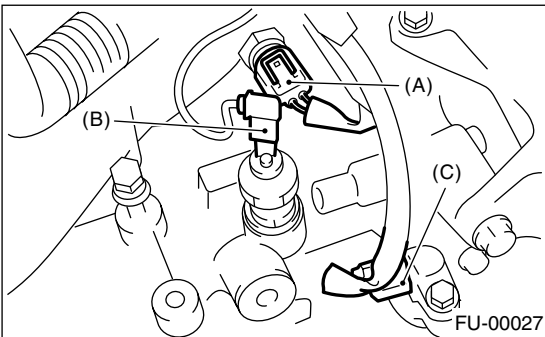

4) Connect the connector to the knock sensor.

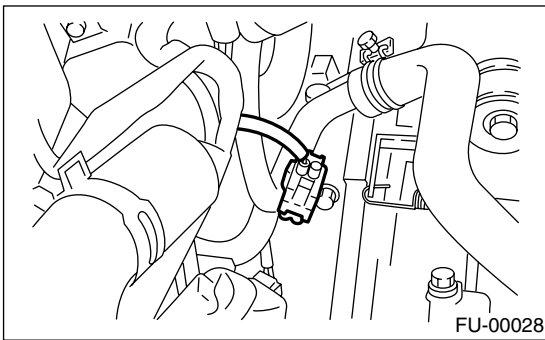

5) Connect the connector to the camshaft position sensor.

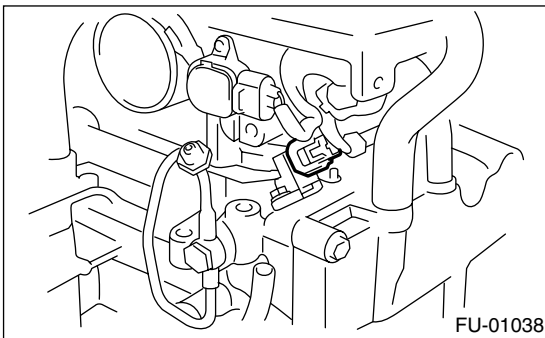

6) Connect the connector to the ignition coil.

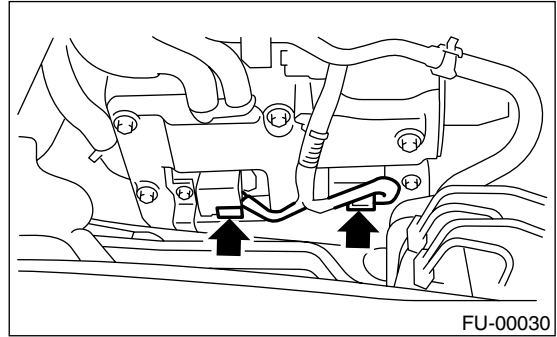

7) Connect the engine harness with clip (A) to the bracket.

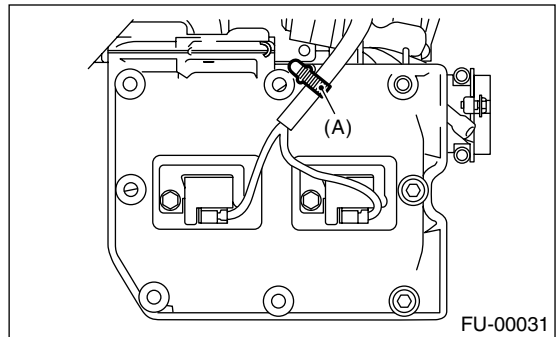

8) Connect the engine harness connector to the bulkhead harness connectors.

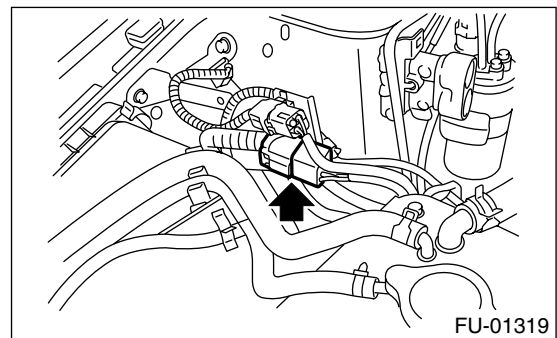
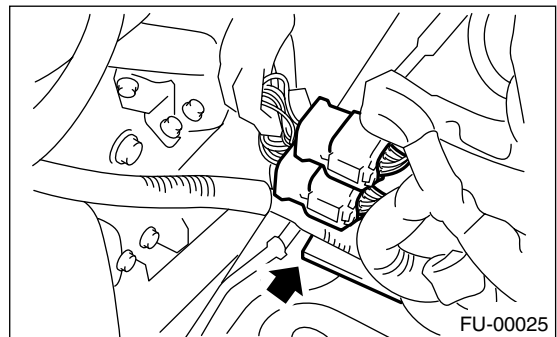

INTAKE MANIFOLD

FUEL INJECTION (FUEL SYSTEMS)

9) Connect the brake booster vacuum hose.

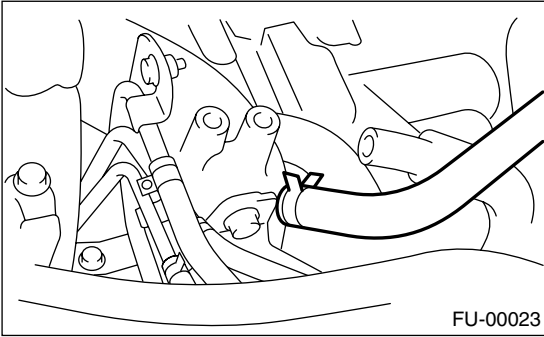

10) Connect the engine coolant hoses to the throttle body.

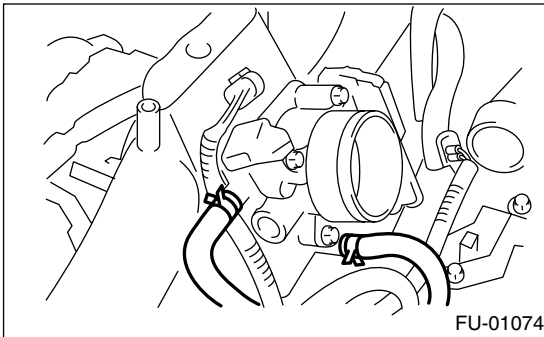

11) Connect the emission hose (A) and connector (B) to the PCV hose assembly.

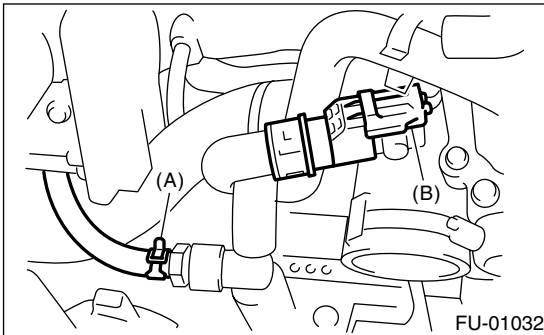

12) Connect the pressure hose to the intake duct.

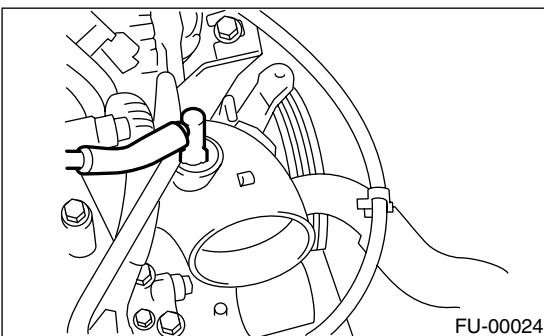

13) Install the power steering pump.

(1) Install the power steering tank on the bracket.

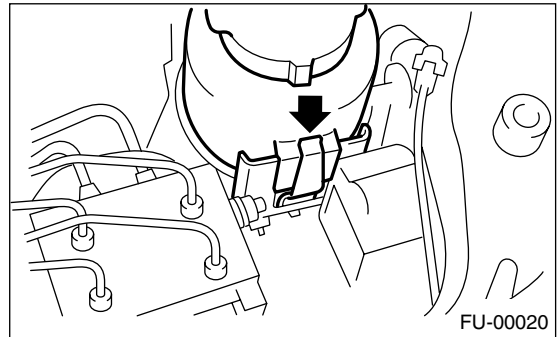

(2) Connect the connector to the power steering pump switch.

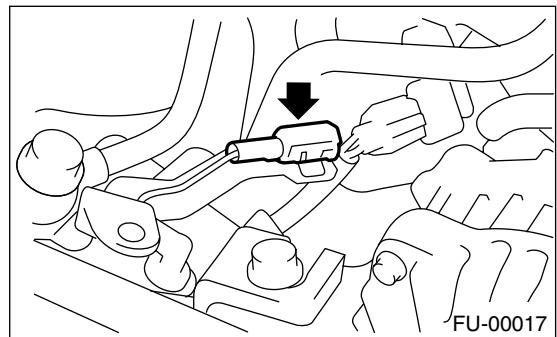

(3) Install the power steering pump, and tighten the bolts.

Tightening torque:

22 N·m (2.2 kgf-m, 15.9 ft-lb)

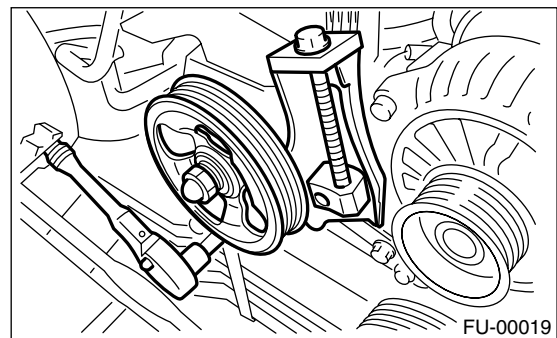

(4) Install the power steering pipe brackets on the intake manifold RH.

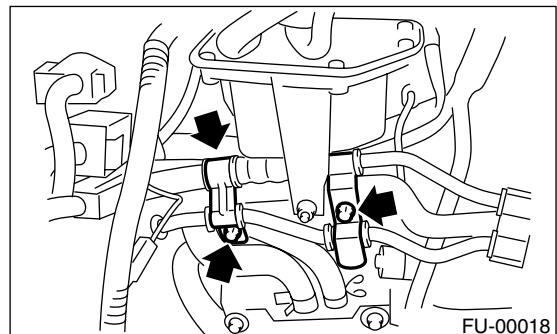

INTAKE MANIFOLD

FUEL INJECTION (FUEL SYSTEMS)

- (5) Install the front side V-belt. <Ref. to ME(H4DOTC)-45, REMOVAL, V-belt.>
- 14) Install the coolant filler tank. <Ref. to CO(H4DOTC)-29, INSTALLATION, Coolant Filler Tank.>
- 15) Install the intercooler. <Ref. to IN(H4DOTC)-11, INSTALLATION, Intercooler.>
- 16) Install the air cleaner element.
- 17) Install the air cleaner upper cover and air intake duct as a unit. <Ref. to IN(H4DOTC)-7, INSTALLATION, Air Cleaner.>
- 18) Connect the connector to the fuel pump relay.

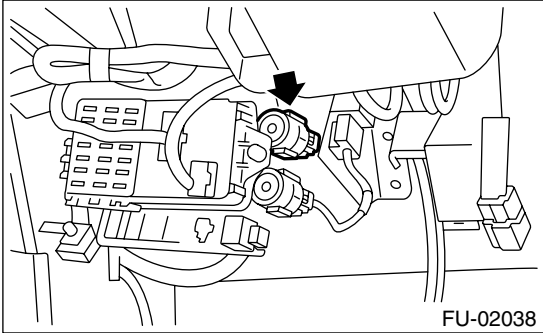

- 19) Connect the battery ground cable to battery.
- 20) Lift up the vehicle.
- 21) Install the under cover.
- 22) Fill the engine coolant. <Ref. to CO(H4DOTC)-13, FILLING OF ENGINE COOLANT, REPLACEMENT, Engine Coolant.>

C: DISASSEMBLY

- 1) Remove the engine ground terminal from the intake manifold.

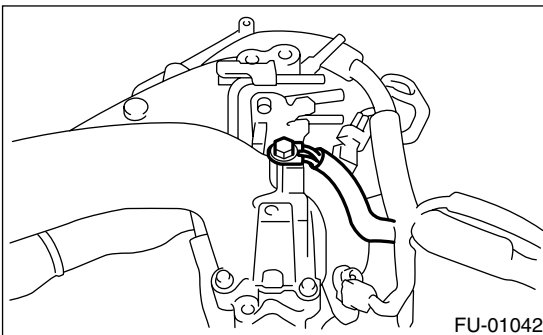
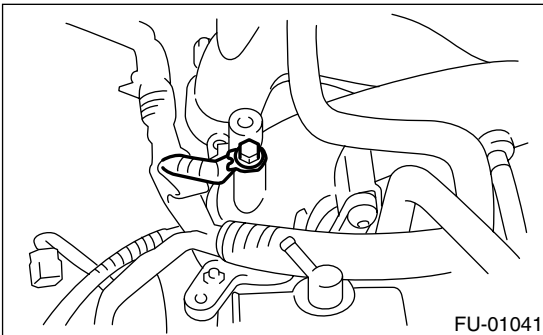

- 2) Disconnect the connector from the throttle position sensor (A) and manifold absolute pressure sensor (B).

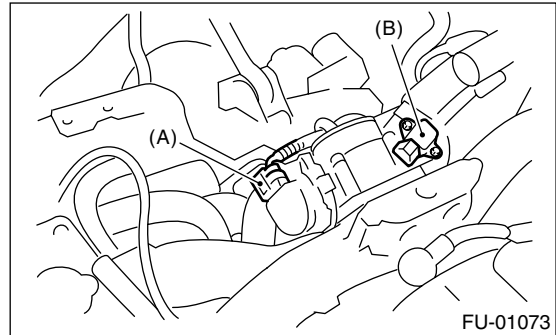

- 3) Remove the throttle body from the intake manifold.

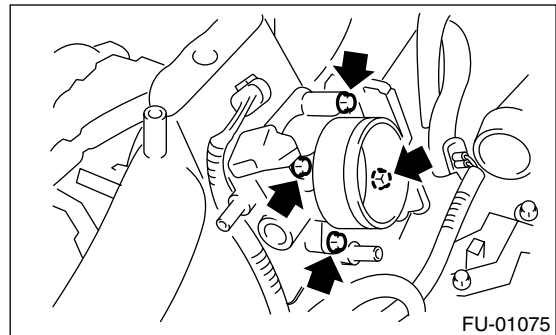

- 4) Disconnect the connector from the fuel injector.

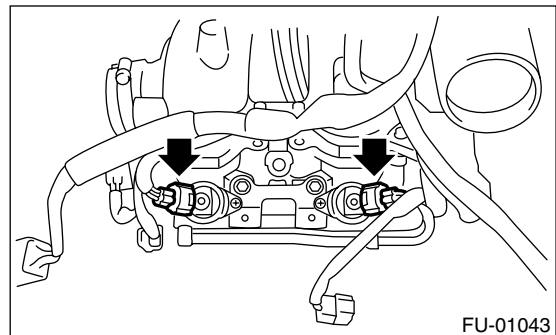

- 5) Disconnect the connector from the tumble generator valve actuator.

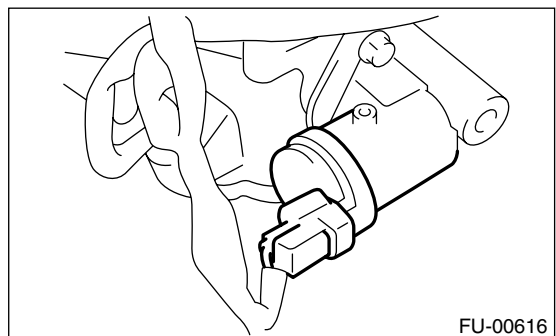

INTAKE MANIFOLD

FUEL INJECTION (FUEL SYSTEMS)

6) Disconnect the connector from the tumble generator valve sensor.

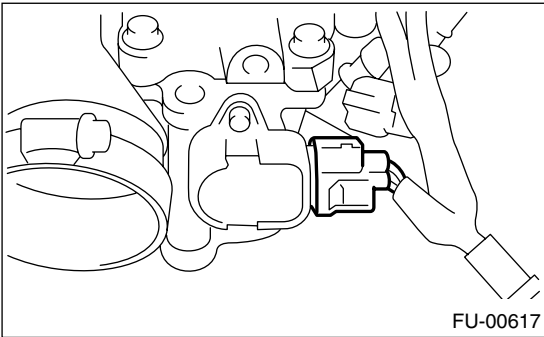

7) Disconnect the connector from the purge control solenoid valve.

8) Remove the purge control solenoid valve.

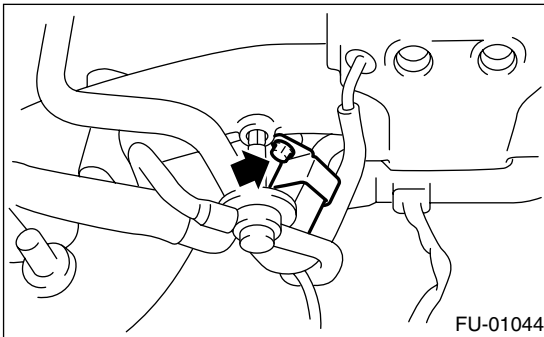

9) Disconnect the evaporation hose and purge valve from the intake manifold.

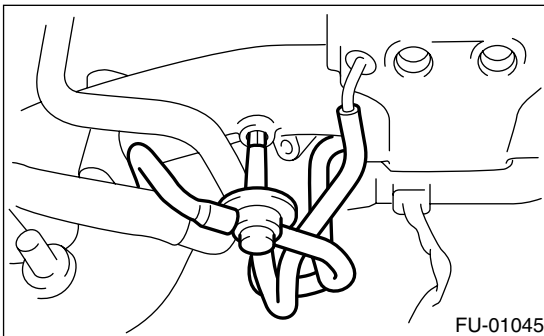

10) Remove the two bolts which hold the fuel pipes on the left side of intake manifold.

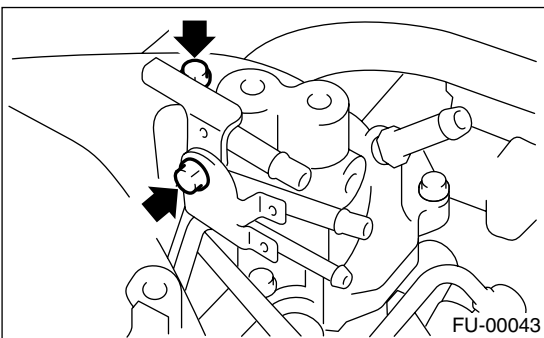

11) Remove the bolt which hold the fuel injector pipe onto intake manifold.

• LH SIDE

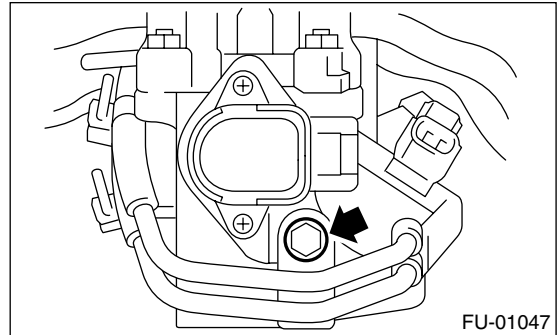
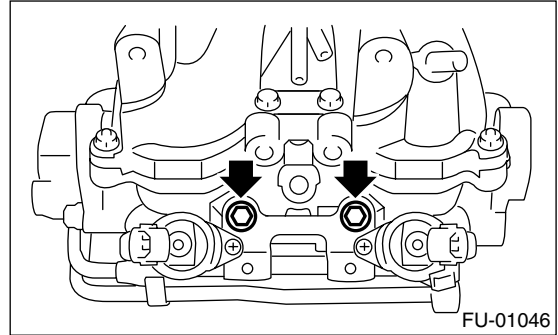

• RH SIDE

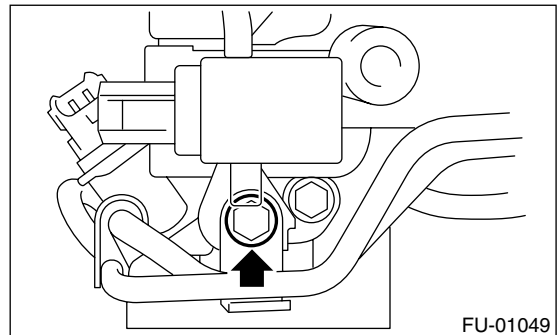
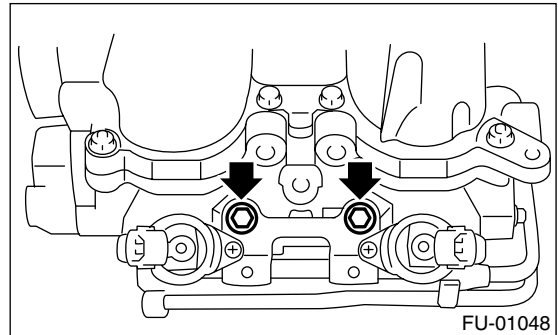

INTAKE MANIFOLD

FUEL INJECTION (FUEL SYSTEMS)

12) Remove the harness bracket which holds the engine harness onto intake manifold.

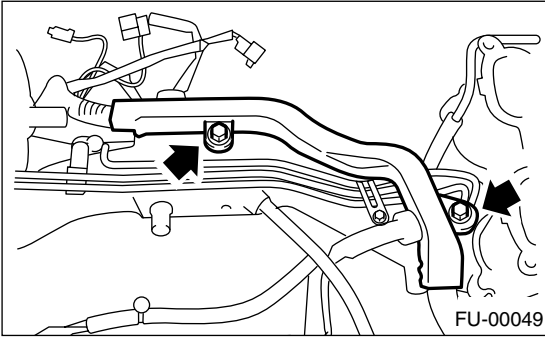

13) Remove the engine harness from the intake manifold.

14) Loosen the clamp which holds the front left side fuel hose to injector pipe, and then remove the pipe from clamp.

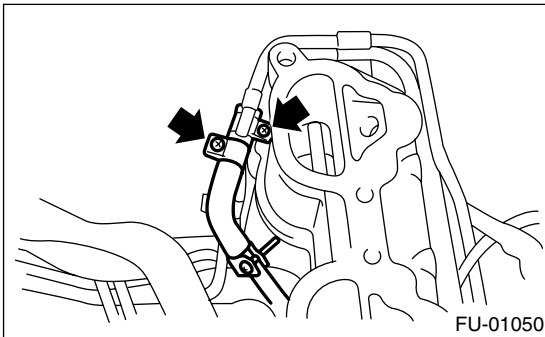

15) Loosen the clamp which holds the right side fuel hose to injector pipe, and then remove the pipe from clamp.

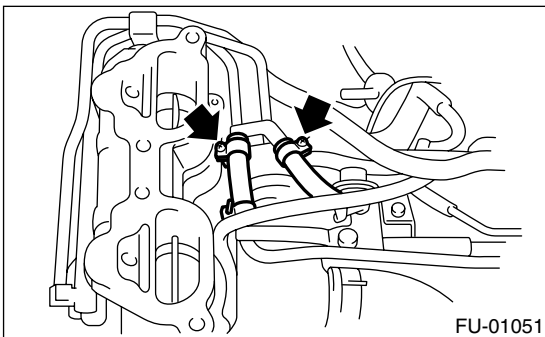

16) Remove the bolts which install the fuel pipe on intake manifold.

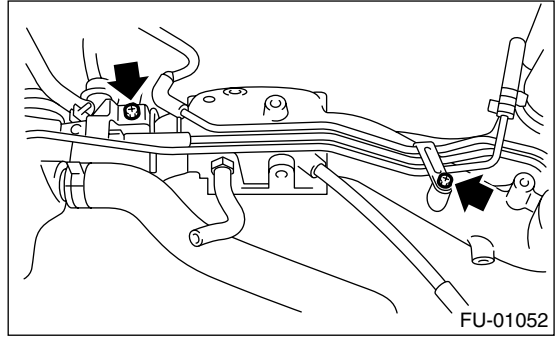

17) Remove the fuel pipe assembly and pressure regulator from the intake manifold.

18) Remove the intake duct from the intake manifold.

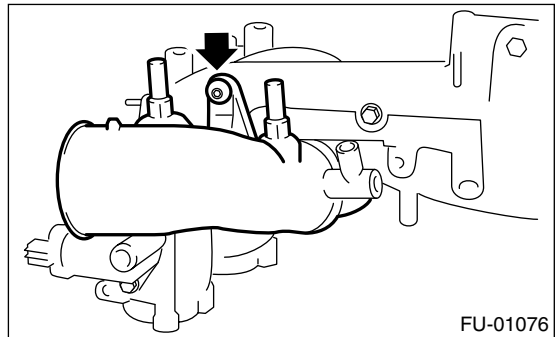

19) Remove the tumble generator valve assembly from the intake manifold.

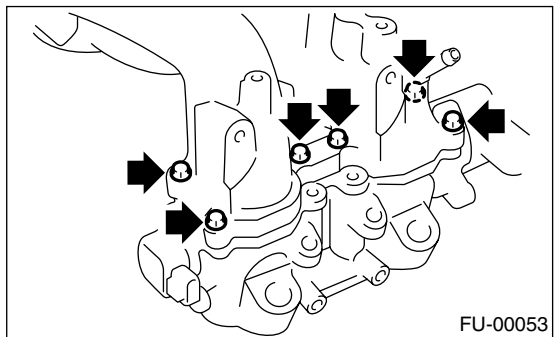

INTAKE MANIFOLD

FUEL INJECTION (FUEL SYSTEMS)

D: ASSEMBLY

NOTE:

Replace the gasket with a new one.

1) Install the tumble generator valve assembly to the intake manifold.

Tightening torque:

8.25 N·m (0.84 kgf-m, 6.1 ft-lb)

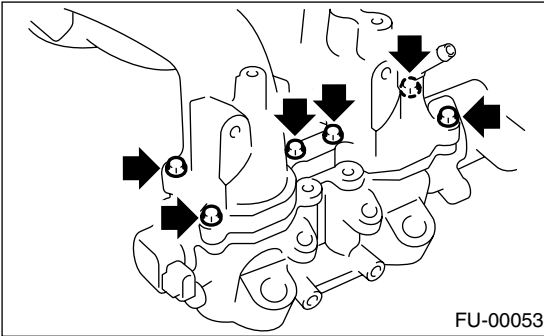

2) Install the air intake duct to the intake manifold.

Tightening torque:

19 N·m (1.94 kgf-m, 13.7 ft-lb)

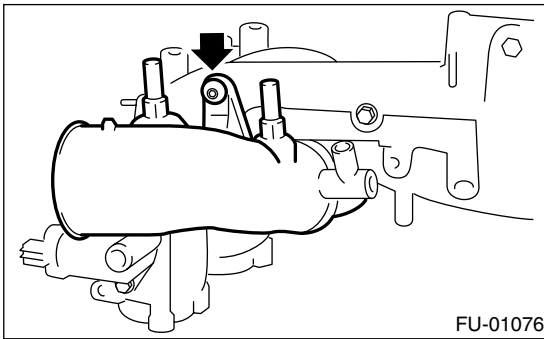

3) Install the fuel pipe assembly and pressure regulator to the intake manifold.

Tightening torque:

4.9 N·m (0.5 kgf-m, 3.6 ft-lb)

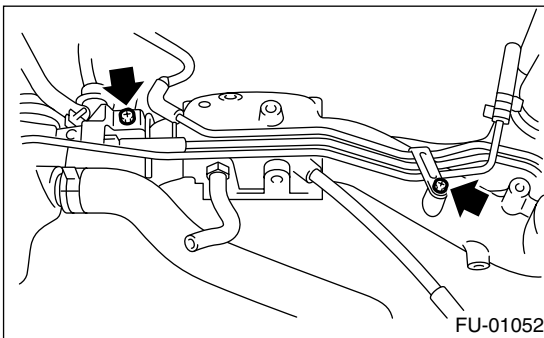

4) Install the fuel injector pipe LH.

5) Connect the left side fuel hose to injector pipe, and tighten the clamp screw.

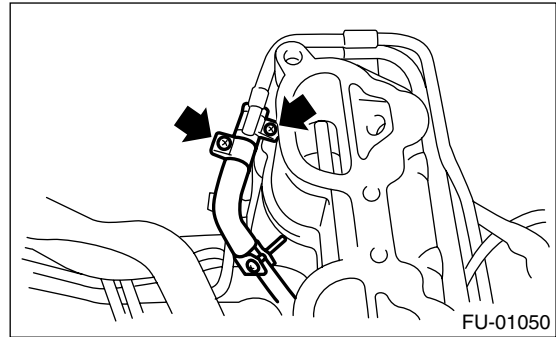

6) Install the fuel injector pipe RH.

7) Connect the right side fuel hose to injector pipe, and tighten the clamp screw.

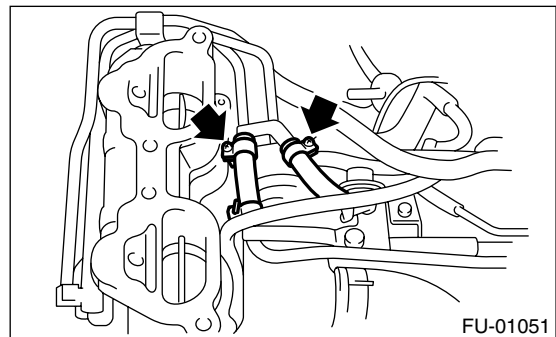

8) Install the engine harness to the intake manifold.

9) Install the harness bracket which holds the engine harness onto intake manifold.

Tightening torque:

19 N·m (1.94 kgf-m, 13.7 ft-lb)

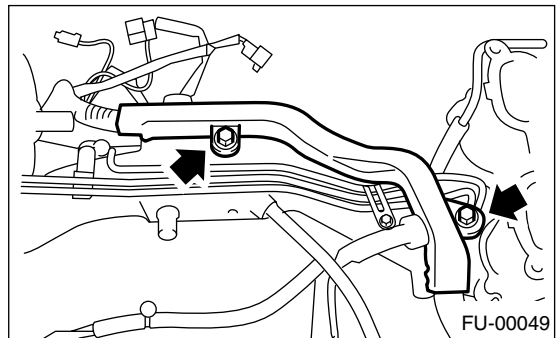

10) Tighten the bolts which install the fuel injector pipe onto intake manifold.

Tightening torque:

19 N·m (1.94 kgf-m, 13.7 ft-lb)

INTAKE MANIFOLD

FUEL INJECTION (FUEL SYSTEMS)

• LH SIDE

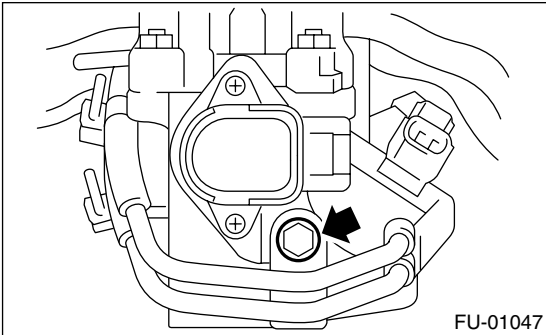
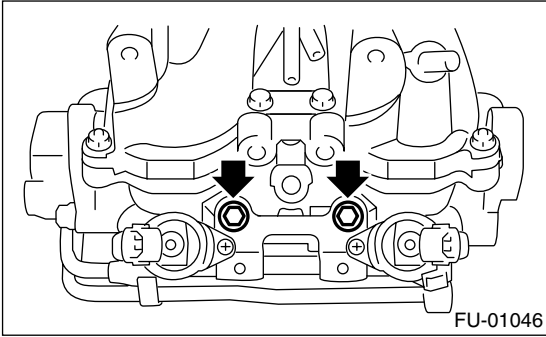

• RH SIDE

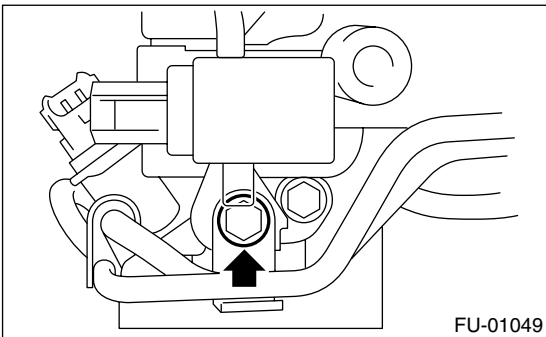
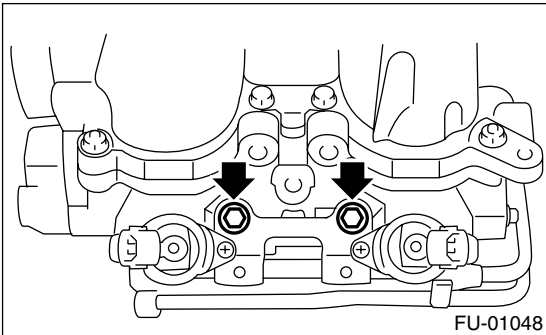

11) Tighten the two bolts which install the fuel pipes on the left side of intake manifold.

Tightening torque:
5 N·m (0.5 kgf-m, 3.6 ft-lb)

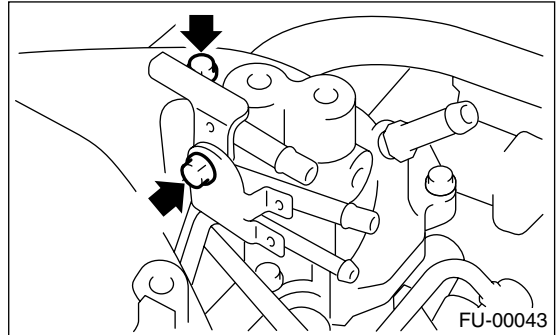

12) Connect the evaporation hoses to the purge valve.

NOTE:
Connect the evaporation hoses as shown in the figure.

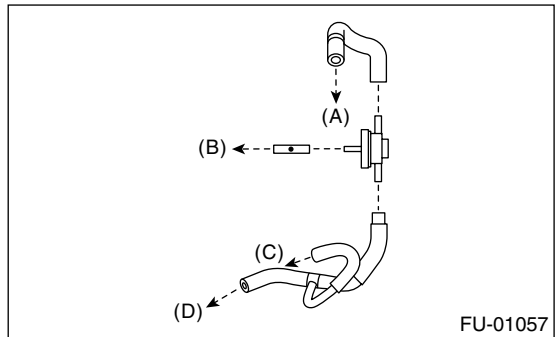

- (A) To intake duct
- (B) To intake manifold
- (C) To purge control solenoid valve
- (D) To fuel pipe ASSY

13) Connect the evaporation hose and purge valve to the intake manifold.

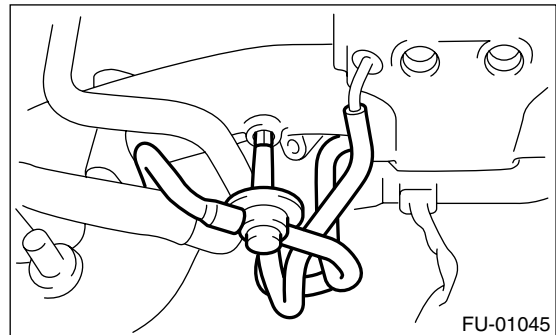

14) Install the purge control solenoid valve.

INTAKE MANIFOLD

FUEL INJECTION (FUEL SYSTEMS)

Tightening torque:

16 N·m (1.6 kgf·m, 11.8 ft·lb)

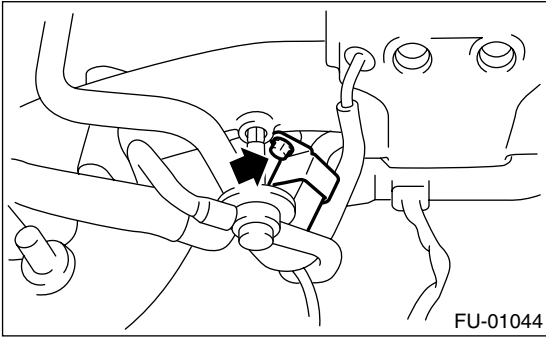

15) Connect the hoses to the purge control solenoid valve.

NOTE:

Connect the evaporation hoses as shown in the figure.

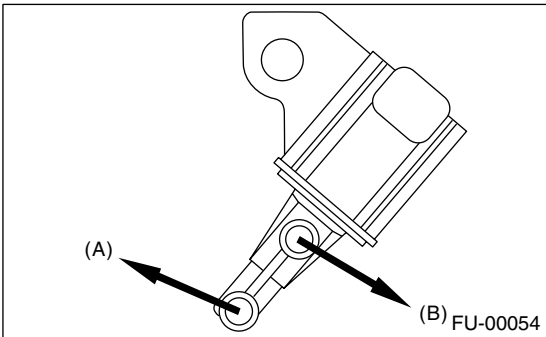

(A) To purge valve

(B) To intake manifold

16) Connect the connector to the purge control solenoid valve.

17) Connect the connector to the tumble generator valve sensor.

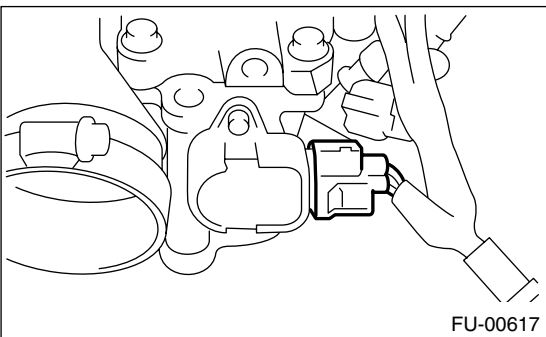

18) Connect the connector to the tumble generator valve actuator.

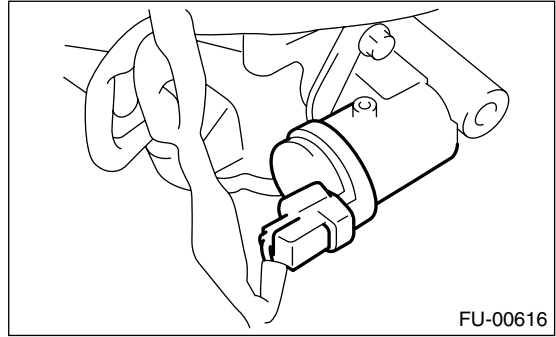

19) Connect the connector to the fuel injector.

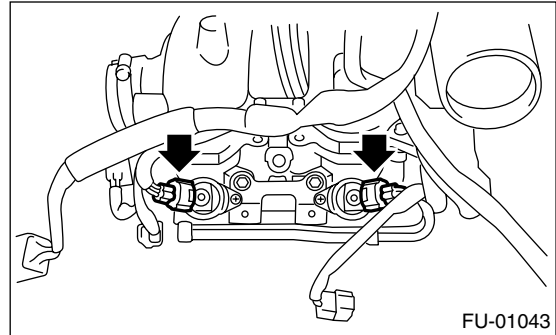

20) Install the throttle body to the intake manifold.

NOTE:

Replace the gasket with a new one.

Tightening torque:

8 N·m (0.8 kgf·m, 5.8 ft·lb)

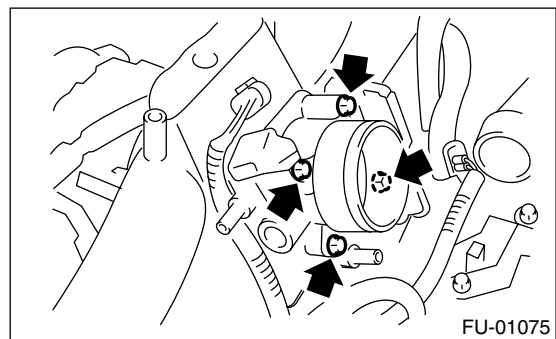

INTAKE MANIFOLD

FUEL INJECTION (FUEL SYSTEMS)

21) Connect the connector to the throttle position sensor (A) and manifold absolute pressure sensor (B).

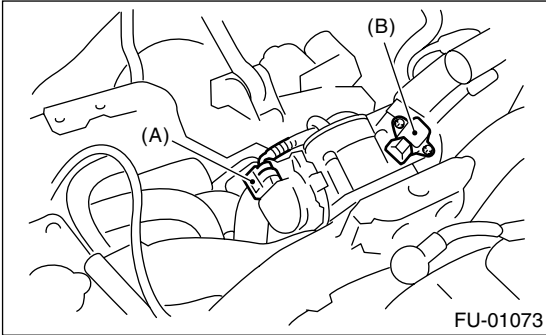

22) Install the engine ground terminal to the intake manifold.

Tightening torque:

19 N·m (1.94 kgf-m, 13.7 ft-lb)

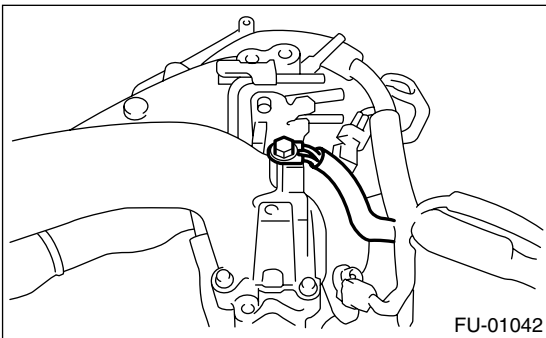
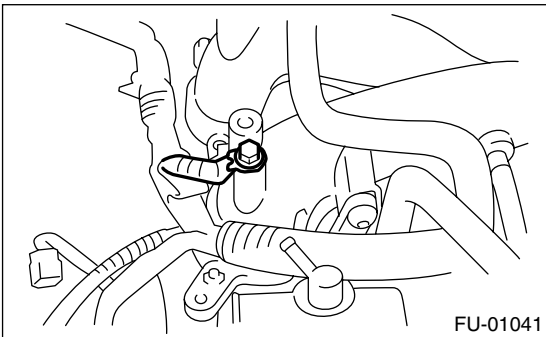

E: INSPECTION

Make sure the fuel pipe and fuel hoses are not cracked and the connections are tightened.

ENGINE COOLANT TEMPERATURE SENSOR

FUEL INJECTION (FUEL SYSTEMS)

4. Engine Coolant Temperature Sensor

A: REMOVAL

- 1) Disconnect the ground cable from battery.

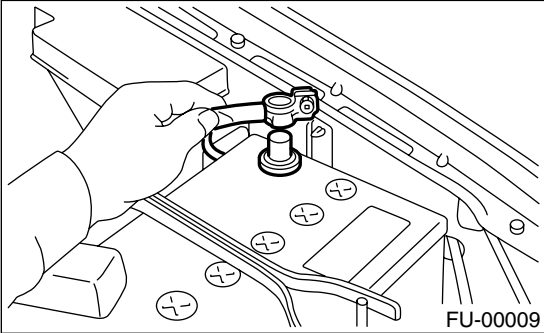

- 2) Remove the generator. <Ref. to SC(H4SO)-15, REMOVAL, Generator.>
- 3) Drain the engine coolant. <Ref. to CO(H4DOTC)-13, DRAINING OF ENGINE COOLANT, REPLACEMENT, Engine Coolant.>
- 4) Disconnect the connector from the engine coolant temperature sensor.

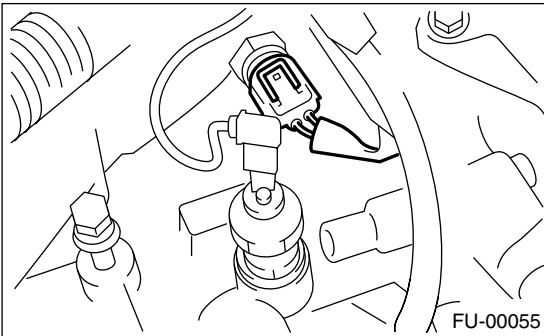

- 5) Remove the engine coolant temperature sensor.

B: INSTALLATION

Install in the reverse order of removal.

Tightening torque:

18 N·m (1.8 kgf-m, 13.3 ft-lb)

CRANKSHAFT POSITION SENSOR

FUEL INJECTION (FUEL SYSTEMS)

5. Crankshaft Position Sensor

A: REMOVAL

1) Disconnect the ground cable from battery.

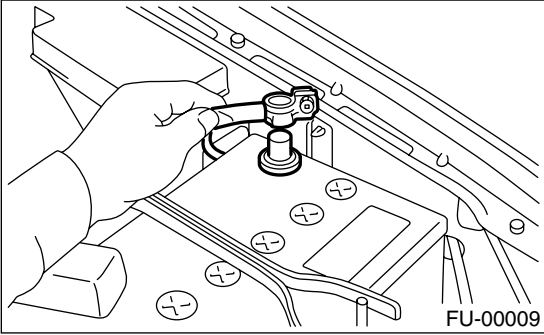

2) Remove the bolt which installs the crankshaft position sensor to cylinder block.

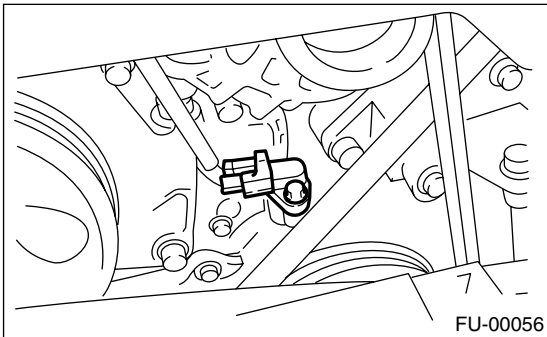

3) Remove the crankshaft position sensor, and disconnect the connector from it.

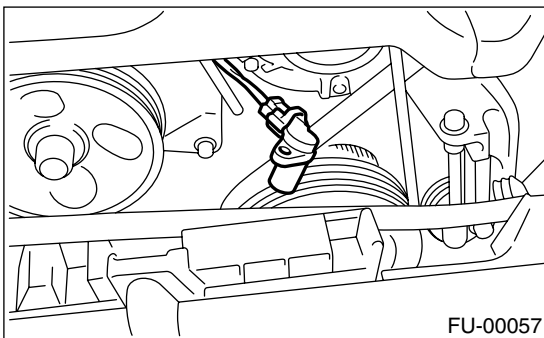

B: INSTALLATION

Install in the reverse order of removal.

Tightening torque:

T: 6.4 N·m (0.65 kgf-m, 4.7 ft-lb)

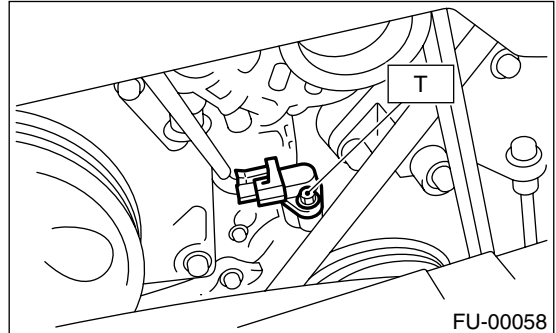

6. Camshaft Position Sensor

A: REMOVAL

- 1) Disconnect the ground cable from battery.

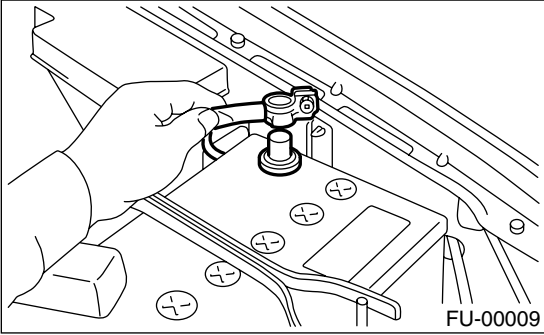

- 2) Disconnect the connector from the camshaft position sensor RH.
- 3) Remove the camshaft position sensor RH from the backside of cylinder head.

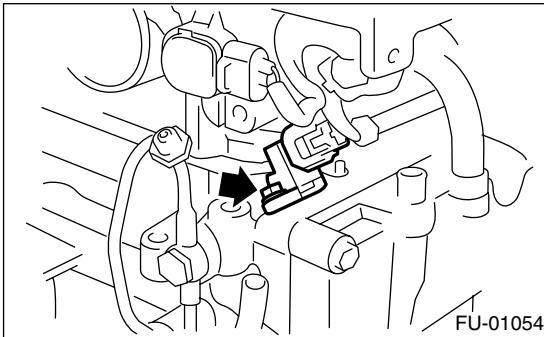

- 4) Remove the camshaft position sensor LH same as RH side.

B: INSTALLATION

Install in the reverse order of removal.

Tightening torque:

T: 6.4 N·m (0.65 kgf-m, 4.7 ft-lb)

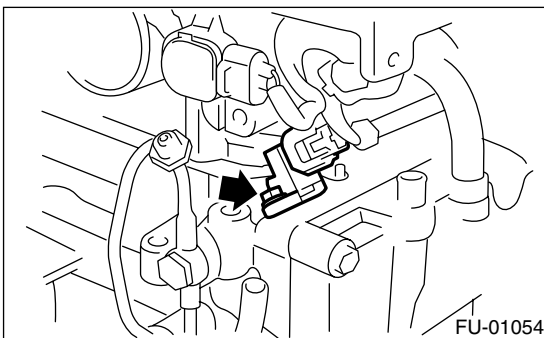

KNOCK SENSOR

FUEL INJECTION (FUEL SYSTEMS)

7. Knock Sensor

A: REMOVAL

1) Disconnect the ground cable from battery.

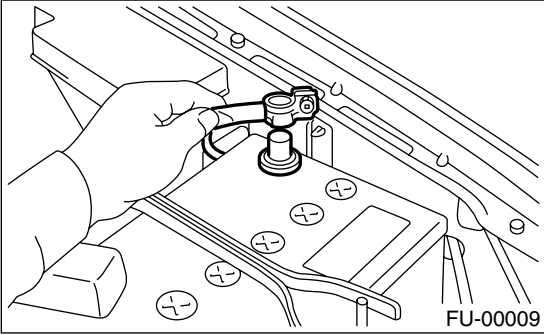

2) Remove the intercooler. <Ref. to IN(H4DOTC)-10, REMOVAL, Intercooler.>

3) Disconnect the knock sensor connector.

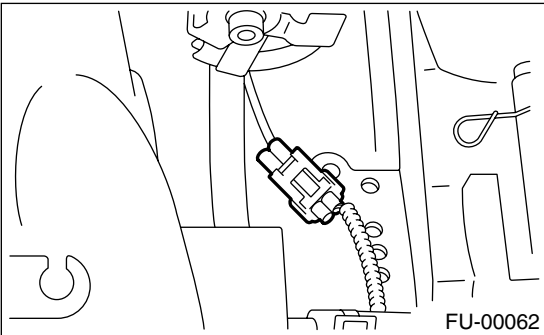

4) Remove the knock sensor from the cylinder block.

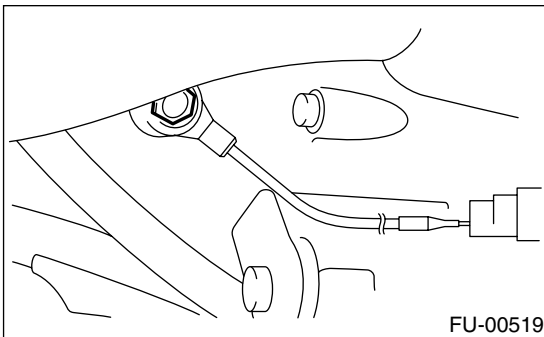

B: INSTALLATION

1) Install the knock sensor to the cylinder block.

Tightening torque:

24 N·m (2.4 kgf-m, 17.4 ft-lb)

NOTE:

Extraction area of the knock sensor cord must be positioned at a 60° angle relative to the engine rear.

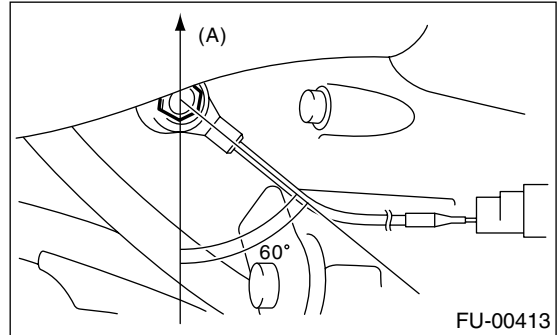

(A) Front side

2) Connect the knock sensor connector.

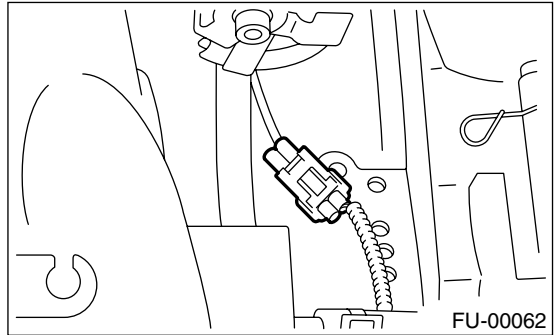

3) Install the intercooler. <Ref. to IN(H4DOTC)-11, INSTALLATION, Intercooler.>

4) Connect the battery ground cable to battery.

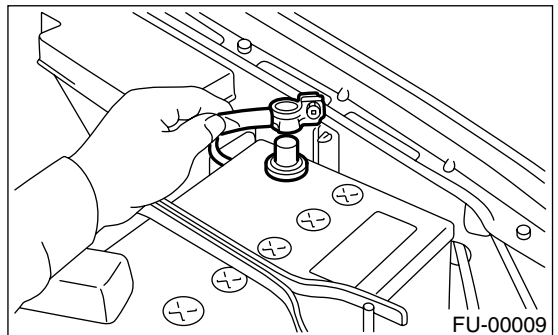

8. Mass Air Flow and Intake Air Temperature Sensor

A: REMOVAL

- 1) Disconnect the ground cable from battery.

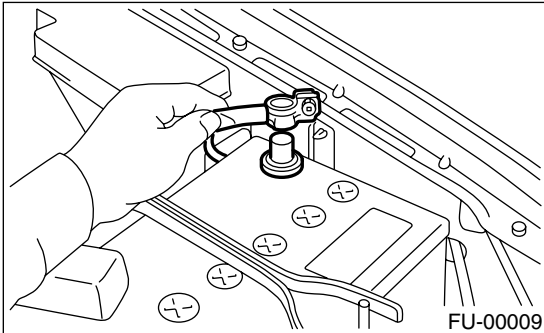

- 2) Disconnect the connector from mass air flow and intake air temperature sensor.
- 3) Remove the mass air flow and intake air temperature sensor.

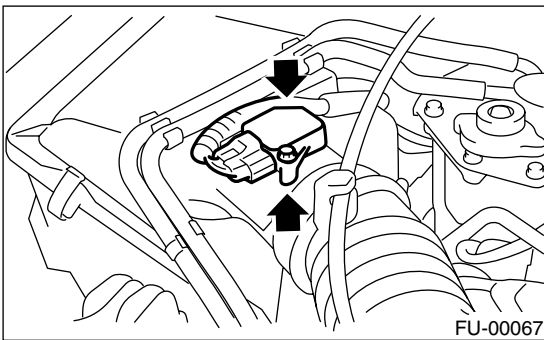

B: INSTALLATION

Install in the reverse order of removal.

Tightening torque:

1.7 N·m (0.17 kgf-m, 1.3 ft-lb)

MANIFOLD ABSOLUTE PRESSURE SENSOR

FUEL INJECTION (FUEL SYSTEMS)

9. Manifold Absolute Pressure Sensor

A: REMOVAL

1) Disconnect the ground cable from battery.

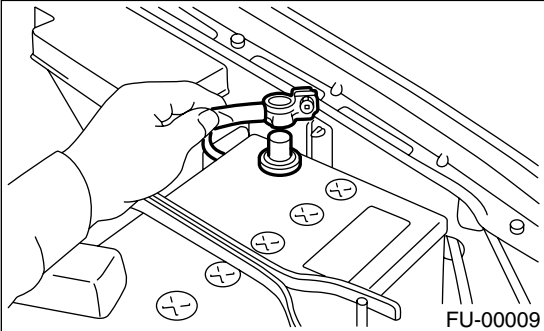

2) Disconnect the connectors from manifold absolute pressure sensor.

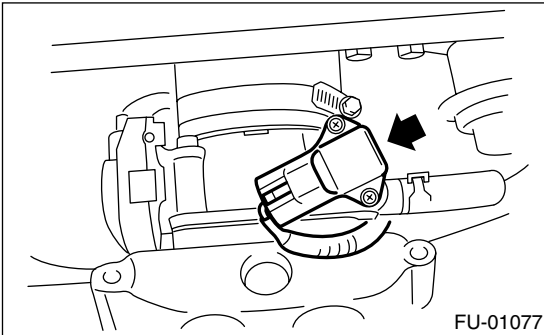

3) Remove the manifold absolute pressure sensor from the throttle body.

B: INSTALLATION

Install in the reverse order of removal.

NOTE:

Replace the O-rings for the manifold absolute pressure sensor with new ones.

Tightening torque:

1.6 N·m (0.16 kgf·m, 1.2 ft·lb)

10. Fuel Injector

A: REMOVAL

1. RH SIDE

- 1) Release the fuel pressure. <Ref. to FU(H4DOTC)-48, RELEASING OF FUEL PRESSURE, OPERATION, Fuel.>
- 2) Open the fuel filler flap lid and remove the fuel filler cap.
- 3) Disconnect the ground cable from battery.

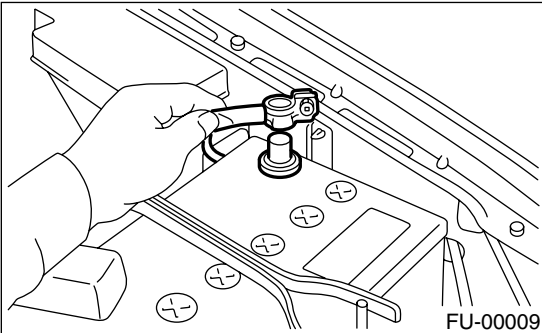

- 4) Disconnect the connector from the fuel injector.
- 5) Remove the screw and remove the fuel injector.

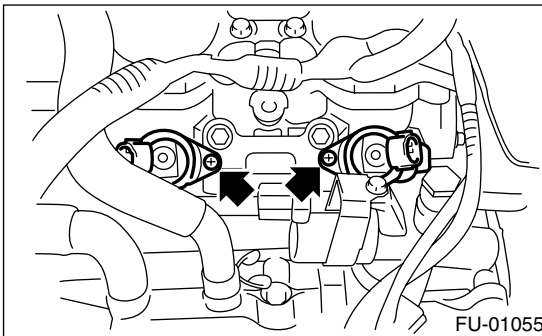

2. LH SIDE

- 1) Release the fuel pressure. <Ref. to FU(H4DOTC)-48, RELEASING OF FUEL PRESSURE, OPERATION, Fuel.>
- 2) Open the fuel filler flap lid and remove the fuel filler cap.
- 3) Disconnect the ground cable from battery.

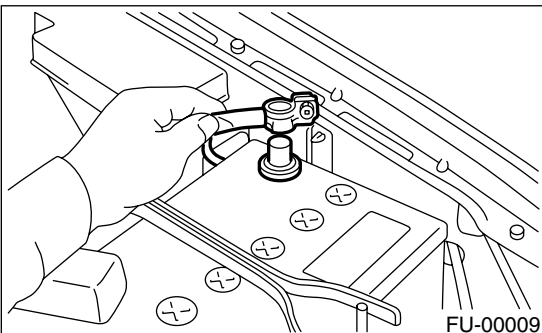

- 4) Remove the intake manifold. <Ref. to FU(H4DOTC)-15, REMOVAL, Intake Manifold.>
- 5) Disconnect the connector from the fuel injector.
- 6) Remove the screw and remove the fuel injector.

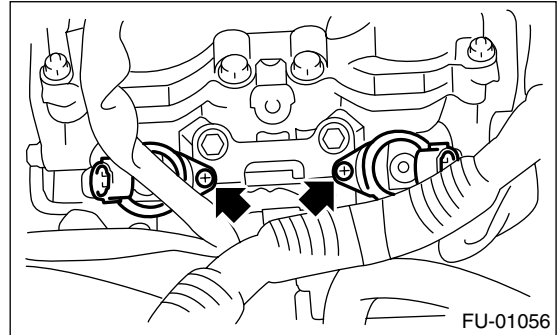

B: INSTALLATION

1. RH SIDE

Install in the reverse order of removal.

NOTE:

Replace the O-rings with new ones.

2. LH SIDE

Install in the reverse order of removal.

NOTE:

Replace the O-rings with new ones.

TUMBLE GENERATOR VALVE ASSEMBLY

FUEL INJECTION (FUEL SYSTEMS)

11. Tumble Generator Valve Assembly

A: REMOVAL

- 1) Release the fuel pressure. <Ref. to FU(H4DOTC)-48, RELEASING OF FUEL PRESSURE, OPERATION, Fuel.>
- 2) Open the fuel filler lid and remove the fuel filler cap.
- 3) Disconnect the ground cable from battery.

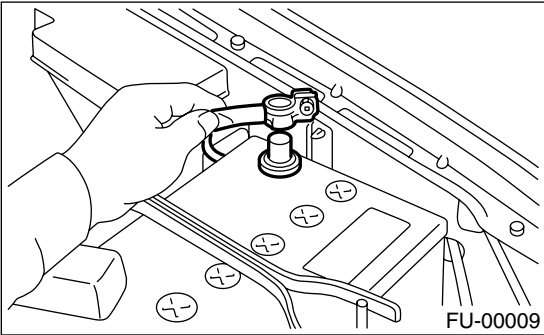

- 4) Remove the intake manifold. <Ref. to FU(H4DOTC)-15, REMOVAL, Intake Manifold.>
- 5) Disconnect the connector from the tumble generator valve sensor.

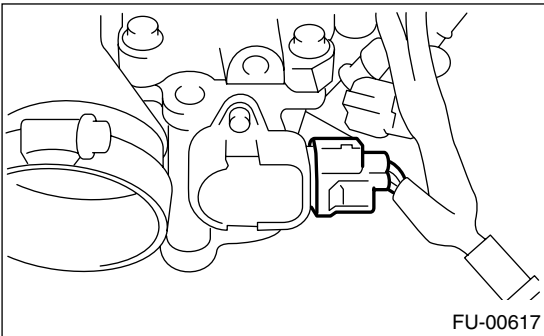

- 6) Disconnect the connector from the tumble generator valve actuator.

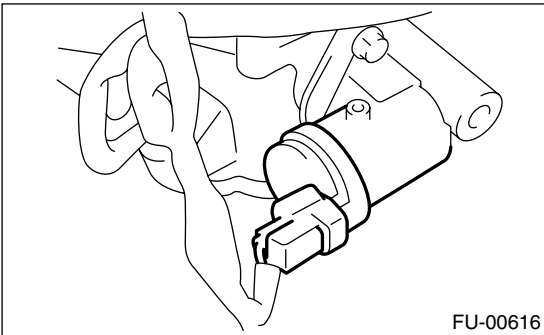

- 7) Remove the fuel injector. <Ref. to FU(H4DOTC)-33, REMOVAL, Fuel Injector.>

- 8) Remove the tumble generator valve body from the intake manifold.

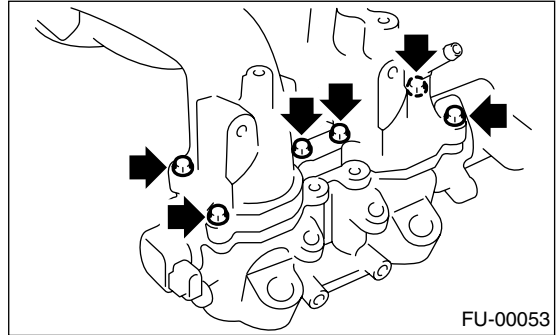

B: INSTALLATION

Install in the reverse order of removal.

NOTE:

Always use new gaskets.

Tightening torque:

8.25 N·m (0.84 kgf-m, 6.1 ft-lb)

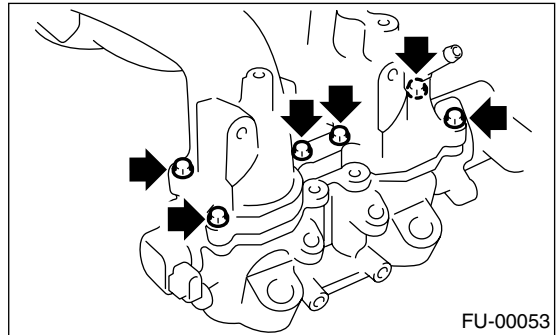

TUMBLE GENERATOR VALVE ACTUATOR

FUEL INJECTION (FUEL SYSTEMS)

12. Tumble Generator Valve Actuator

A: REMOVAL

1. RH SIDE

- 1) Release the fuel pressure. <Ref. to FU(H4DOTC)-48, RELEASING OF FUEL PRESSURE, OPERATION, Fuel.>
- 2) Open the fuel filler lid and remove the fuel filler cap.
- 3) Disconnect the ground cable from battery.

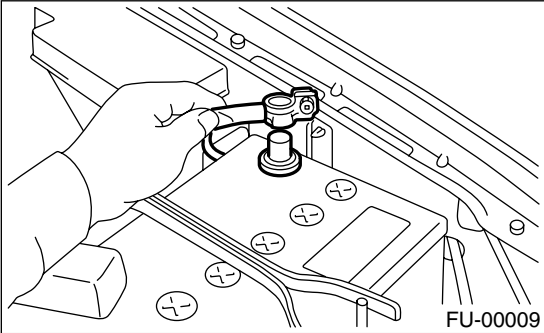

- 4) Remove the intake manifold. <Ref. to FU(H4DOTC)-15, REMOVAL, Intake Manifold.>
- 5) Disconnect the connector from tumble generator valve actuator RH.
- 6) Remove the tumble generator valve actuator RH.

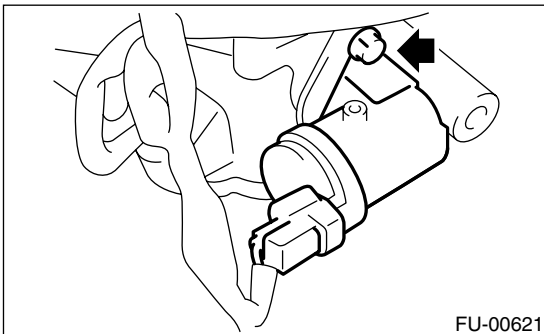

2. LH SIDE

- 1) Release the fuel pressure. <Ref. to FU(H4DOTC)-48, RELEASING OF FUEL PRESSURE, OPERATION, Fuel.>
- 2) Open the fuel filler lid and remove the fuel filler cap.

- 3) Disconnect the ground cable from battery.

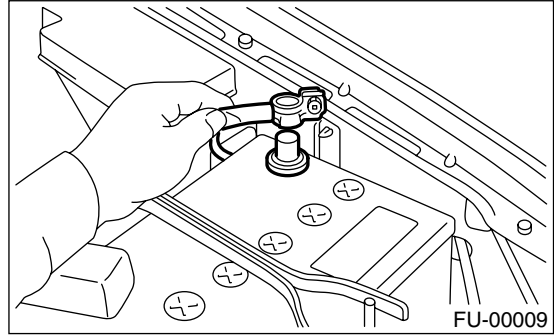

- 4) Disconnect the connector from tumble generator valve actuator LH.
- 5) Remove the tumble generator valve actuator LH.

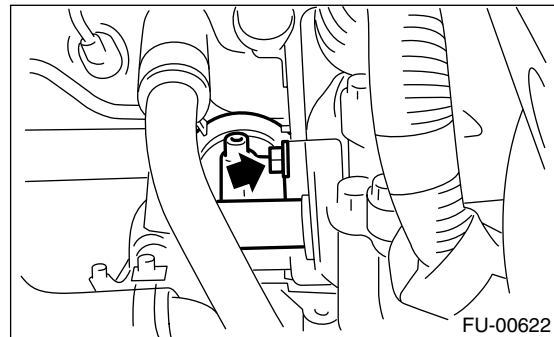

B: INSTALLATION

1. RH SIDE

Install in the reverse order of removal.

2. LH SIDE

Install in the reverse order of removal.

13. Tumble Generator Valve Position Sensor

A: SPECIFICATIONS

Do not remove tumble generator valve position sensor from tumble generator valve assembly because the sensor cannot be adjusted when installing.

For removal and installation, refer to "Tumble Generator Valve Assembly". <Ref. to FU(H4DOTC)-34, REMOVAL, Tumble Generator Valve Assembly.> and <Ref. to FU(H4DOTC)-34, INSTALLATION, Tumble Generator Valve Assembly.>

WASTEGATE CONTROL SOLENOID VALVE

FUEL INJECTION (FUEL SYSTEMS)

14. Wastegate Control Solenoid Valve

A: REMOVAL

1) Disconnect the ground cable from battery.

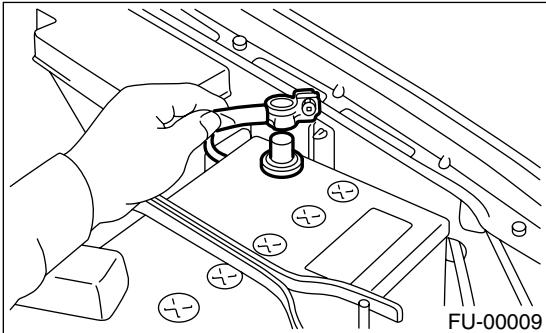

2) Disconnect the engine harness connector (A) from bracket.

3) Disconnect the connector (B) from wastegate control solenoid valve.

4) Remove the bracket from body.

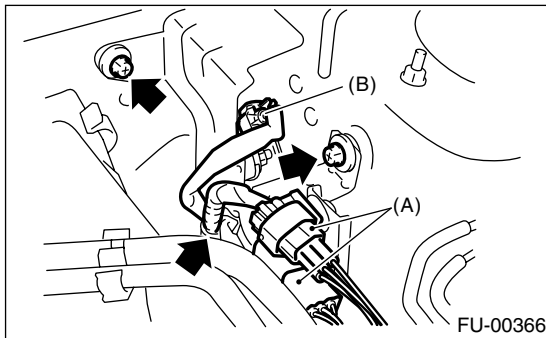

5) Disconnect the pressure hoses (C) from wastegate control solenoid valve.

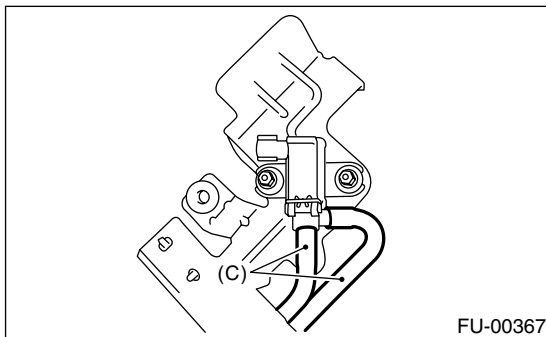

6) Remove the wastegate control solenoid valve from bracket.

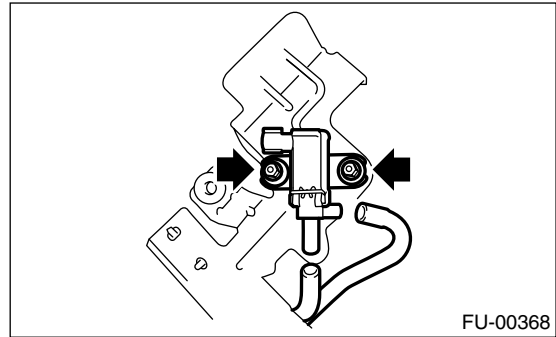

B: INSTALLATION

Install in the reverse order of removal.

Tightening torque:

6.4 N·m (0.65 kgf-m, 4.7 ft-lb)

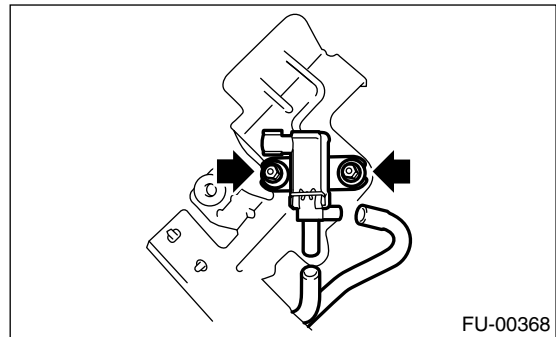

FRONT OXYGEN (A/F) SENSOR

FUEL INJECTION (FUEL SYSTEMS)

15. Front Oxygen (A/F) Sensor

A: REMOVAL

1) Disconnect the ground cable from battery.

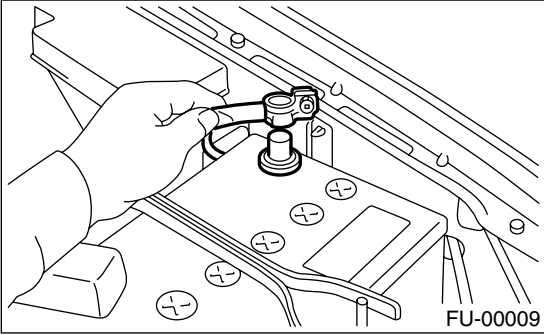

2) Disconnect the connector from the front oxygen (A/F) sensor.

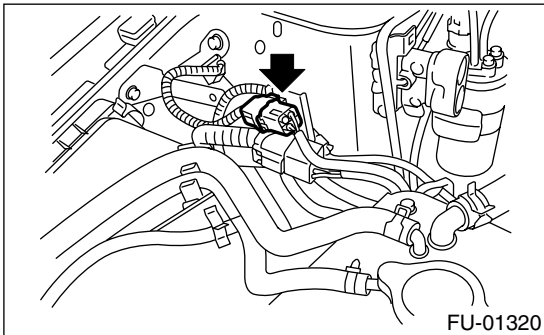

3) Disconnect the engine harness fixed by clip (A).

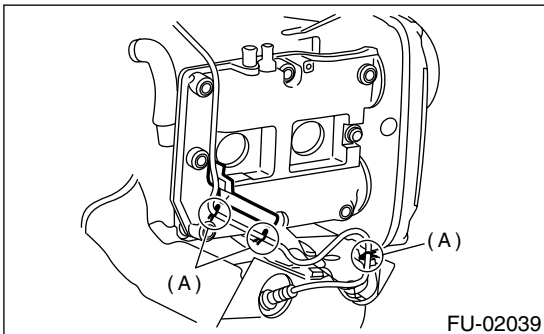

- 4) Remove the front right side wheel.
- 5) Lift-up the vehicle.
- 6) Remove the service hole cover.

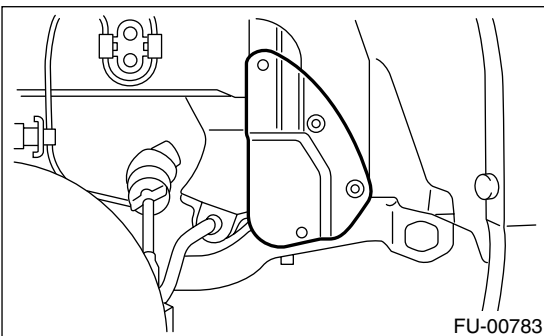

7) Apply SUBARU CRC or its equivalent to the threaded portion of front oxygen (A/F) sensor, and leave it for one minute or more.

SUBARU CRC (Part No. 004301003)

8) Remove the front oxygen (A/F) sensor.

CAUTION:

When removing the oxygen (A/F) sensor, wait until exhaust pipe cools; otherwise, it will damage exhaust pipe.

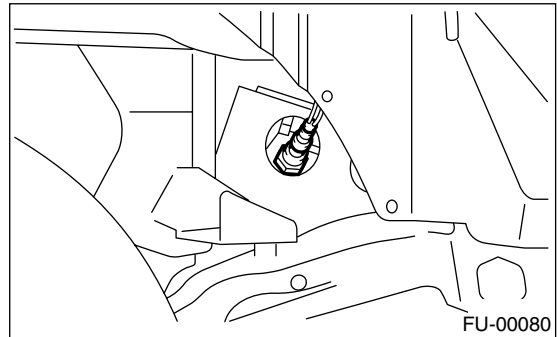

B: INSTALLATION

1) Before installing front oxygen (A/F) sensor, apply anti-seize compound only to the threaded portion of front oxygen (A/F) sensor to make the next removal easier.

Anti-seize compound:

SS-30 by JET LUBE

CAUTION:

Never apply anti-seize compound to protector of front oxygen (A/F) sensor.

2) Install the front oxygen (A/F) sensor.

Tightening torque:

30 N·m (3.1 kgf-m, 22.1 ft-lb)

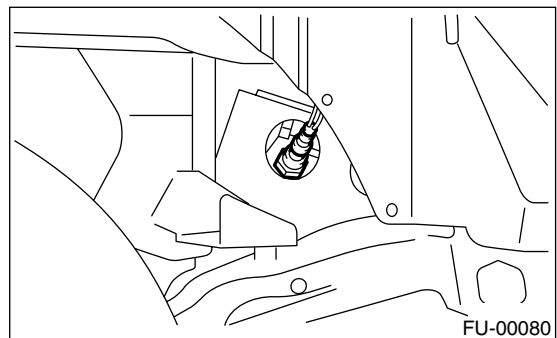

FRONT OXYGEN (A/F) SENSOR

FUEL INJECTION (FUEL SYSTEMS)

3) Install the service hole cover.

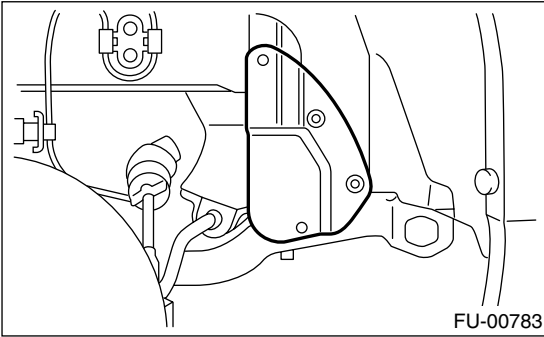

4) Lower the vehicle.

5) Install the front right side wheel.

6) Connect the engine harness using clips (A).

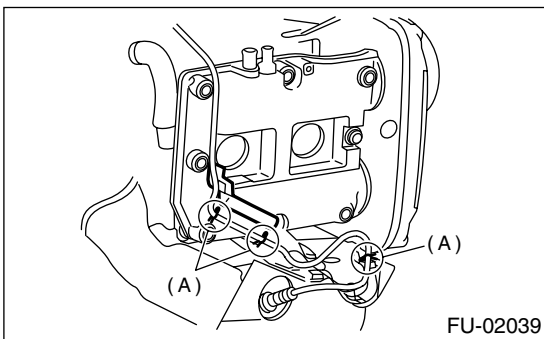

7) Connect the connector of front oxygen (A/F) sensor.

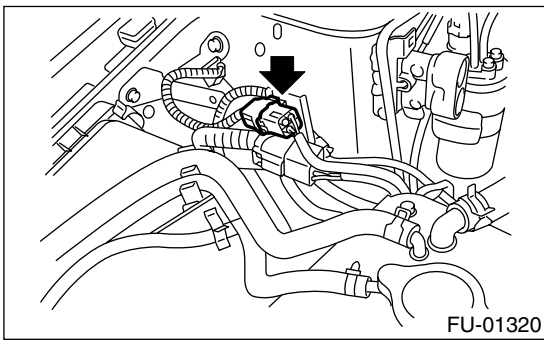

8) Connect the battery ground cable to battery.

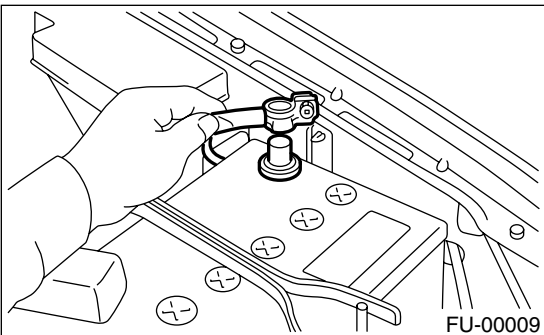

REAR OXYGEN SENSOR

FUEL INJECTION (FUEL SYSTEMS)

16. Rear Oxygen Sensor

A: REMOVAL

1) Disconnect the ground cable from battery.

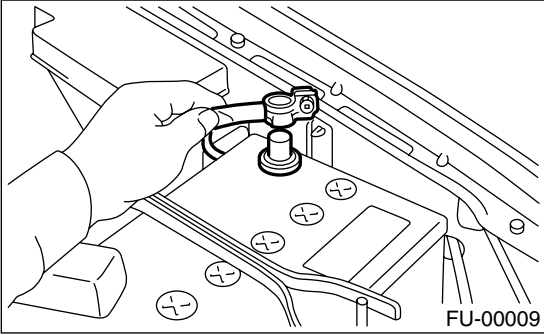

2) Lift-up the vehicle.

3) Disconnect the connector from the rear oxygen sensor.

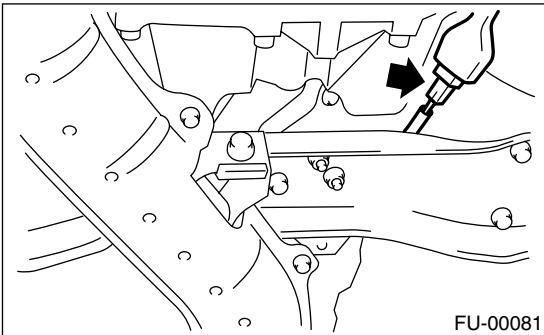

4) Remove the clip by pulling out from the upper side of crossmember.

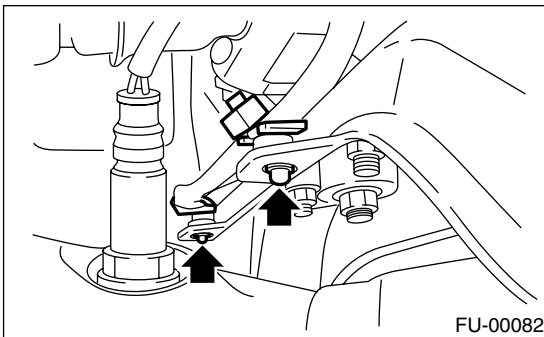

5) Apply SUBARU CRC or its equivalent to the threaded portion of rear oxygen sensor, and leave it for one minute or more.

SUBARU CRC (Part No. 004301003)

6) Remove the rear oxygen sensor.

CAUTION:

When removing the oxygen sensor, wait until exhaust pipe cools; otherwise, it will damage exhaust pipe.

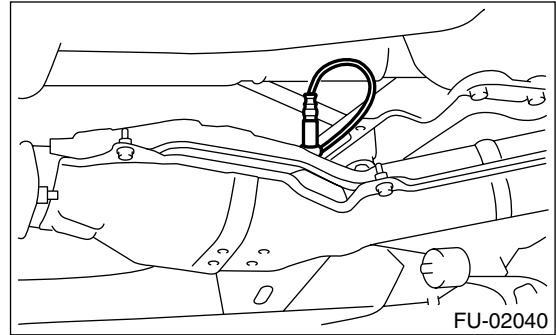

B: INSTALLATION

1) Before installing rear oxygen sensor, apply anti-seize compound only to the threaded portion of rear oxygen sensor to make the next removal easier.

CAUTION:

Never apply anti-seize compound to protector of rear oxygen sensor.

Anti-seize compound:

SS-30 by JET LUBE

2) Install the rear oxygen sensor.

Tightening torque:

21 N·m (2.1 kgf-m, 15.2 ft-lb)

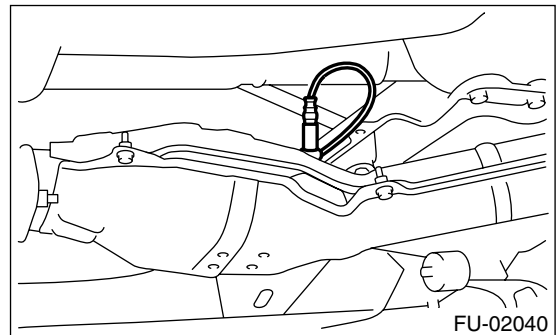

3) Connect the connector to the rear oxygen sensor.

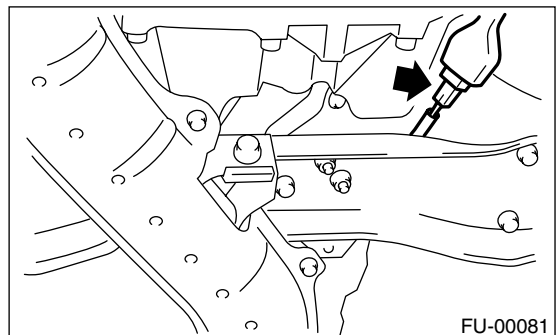

REAR OXYGEN SENSOR

FUEL INJECTION (FUEL SYSTEMS)

4) Connect the clip to the crossmember.

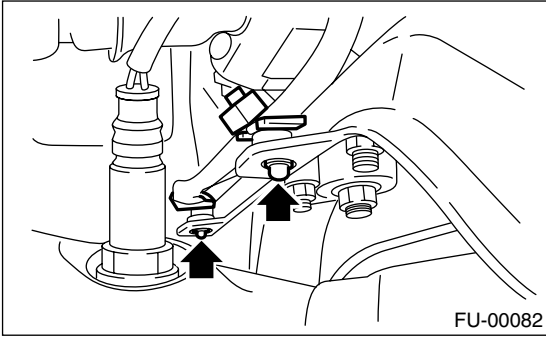

5) Lower the vehicle.

6) Connect the battery ground cable to battery.

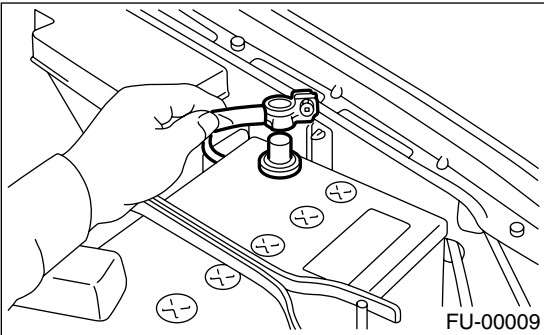

EXHAUST TEMPERATURE SENSOR

FUEL INJECTION (FUEL SYSTEMS)

17. Exhaust Temperature Sensor

A: REMOVAL

1) Disconnect the ground cable from battery.

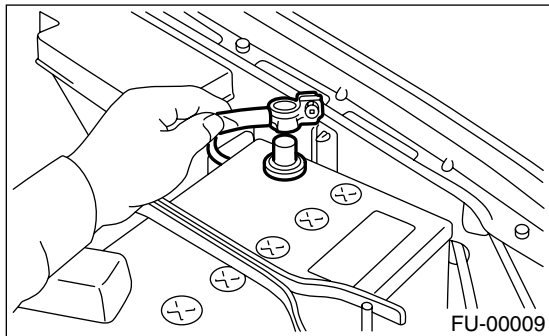

2) Remove the joint pipe. <Ref. to EX(H4DOTC)-13, REMOVAL, Joint Pipe.>

3) Apply SUBARU CRC or its equivalent to the threaded portion of exhaust temperature sensor, and leave it for one minute or more.

SUBARU CRC (Part No. 004301003)

4) Remove the exhaust temperature sensor.

CAUTION:

When removing the exhaust temperature sensor, wait until joint pipe cools, otherwise it will damage exhaust pipe.

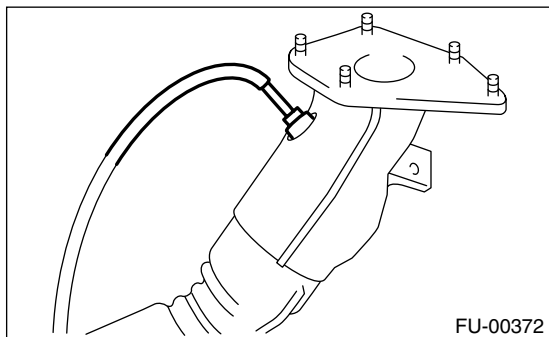

B: INSTALLATION

1) Before installing exhaust temperature sensor, apply anti-seize compound only to the threaded portion of exhaust temperature sensor to make the next removal easier.

CAUTION:

Never apply anti-seize compound to protector of exhaust temperature sensor.

Anti-seize compound:

SS-30 by JET LUBE

2) Install the exhaust temperature sensor.

NOTE:

Align the harness (A) of exhaust temperature sensor to the marking (B) of joint pipe, and tighten the screws.

Tightening torque:

21 N·m (2.1 kgf-m, 15.2 ft-lb)

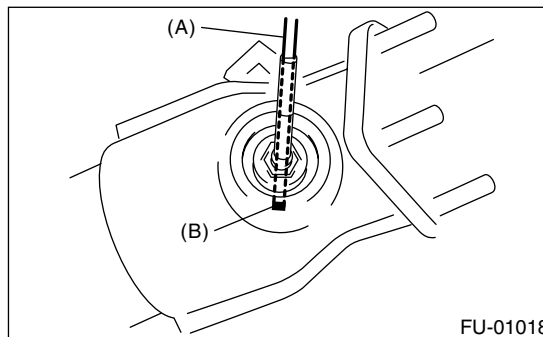

3) Install the joint pipe. <Ref. to EX(H4DOTC)-13, INSTALLATION, Joint Pipe.>

4) Connect the battery ground cable to battery.

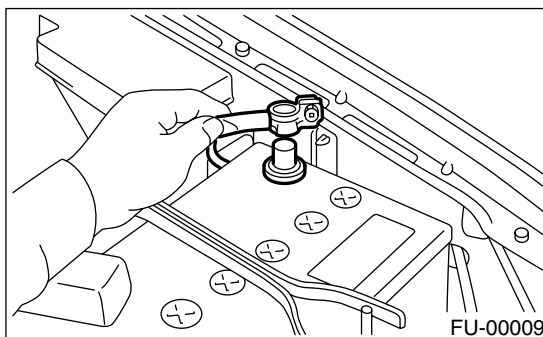

18.Engine Control Module (ECM)

A: REMOVAL

1) Disconnect the ground cable from battery.

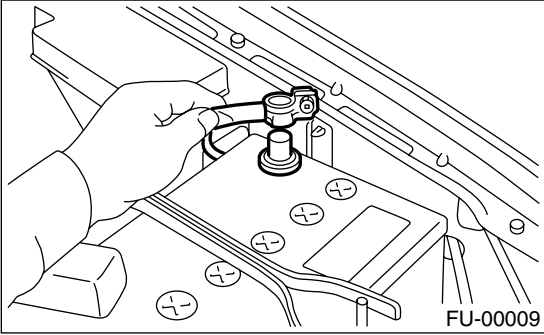

2) Remove the lower inner trim of the passenger side.

<Ref. to EI-51, REMOVAL, Lower Inner Trim.>

3) Detach the floor mat of the front passenger seat.

4) Remove the protect cover.

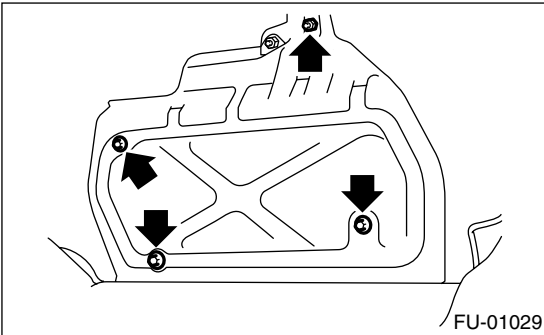

5) Remove the nuts (A) which hold ECM to the bracket.

6) Remove the clip (B) from the bracket.

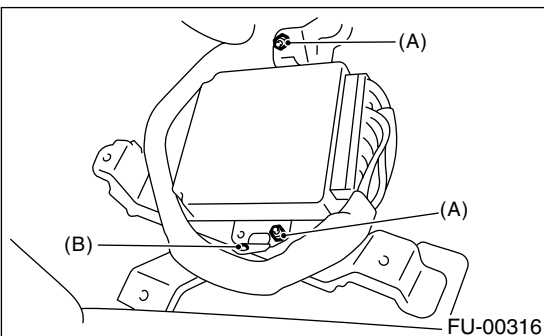

7) Disconnect the ECM connectors and take out the ECM.

B: INSTALLATION

Install in the reverse order of removal.

NOTE:

When replacing ECM, be careful not to use the wrong spec. ECM to avoid any damage to the fuel injection system.

MAIN RELAY

FUEL INJECTION (FUEL SYSTEMS)

19.Main Relay

A: REMOVAL

- 1) Disconnect the ground cable from battery.

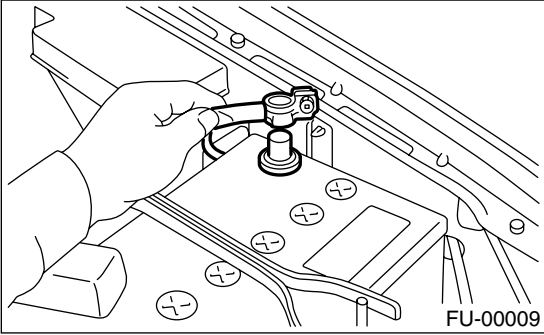

- 2) Remove the driver's side lower cover.
- 3) Disconnect the connectors from the main relay.
- 4) Remove the main relay from the bracket.

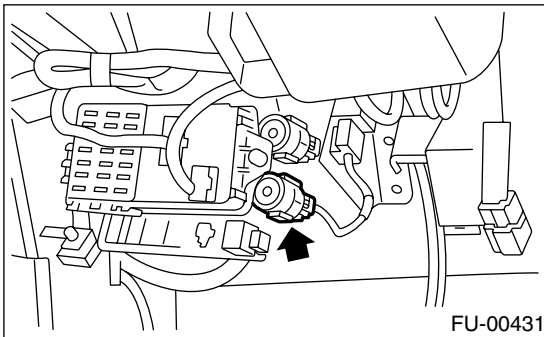

B: INSTALLATION

Install in the reverse order of removal.

20. Fuel Pump Relay

A: REMOVAL

- 1) Disconnect the ground cable from battery.

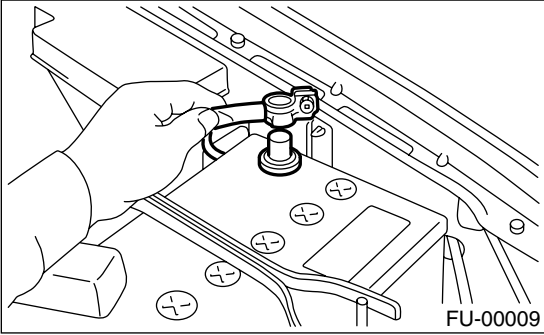

- 2) Remove the driver's side lower cover.
- 3) Disconnect the connector from the fuel pump relay.
- 4) Remove the fuel pump relay from the bracket.

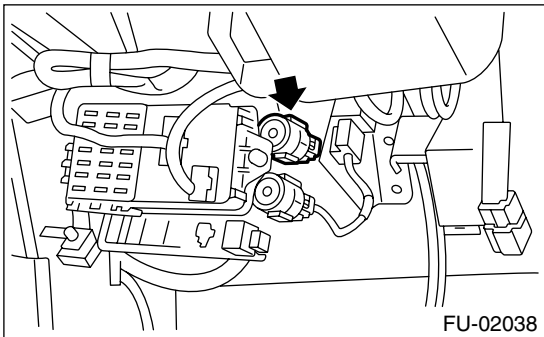

- 5) Remove the fuel pump relay from the mounting bracket.

B: INSTALLATION

Install in the reverse order of removal.

ELECTRONIC CONTROL THROTTLE RELAY

FUEL INJECTION (FUEL SYSTEMS)

21. Electronic Control Throttle Relay

A: REMOVAL

1) Disconnect ground cable from battery.

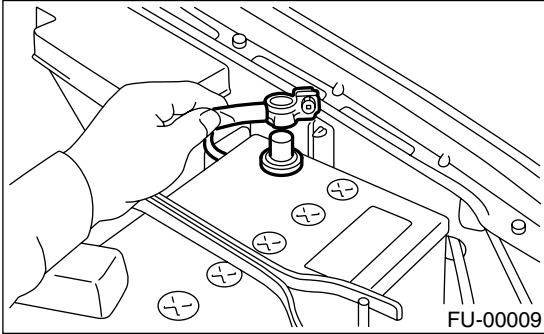

2) Disconnect connector from the passenger's side electronic control throttle relay.

3) Remove the electronic control throttle relay from the bracket.

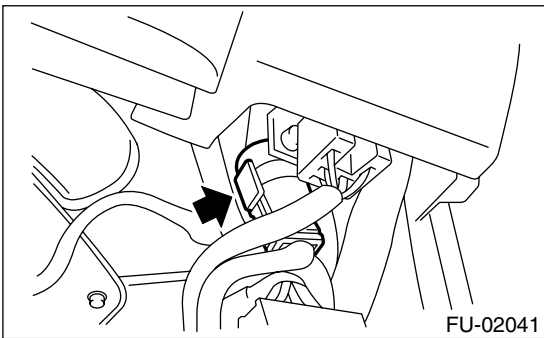

B: INSTALLATION

Install in the reverse order of removal.

22. Fuel Pump Control Unit

A: REMOVAL

- 1) Disconnect the ground cable from battery.

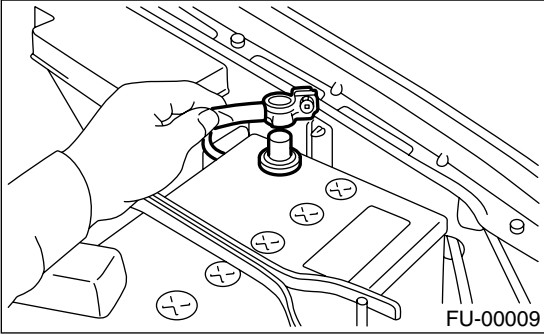

- 2) Remove the rear pillar trim. <Ref. to EI-69, REMOVAL, Rear Pillar Trim.>
- 3) Remove the fuel pump control unit bracket from the vehicle body.

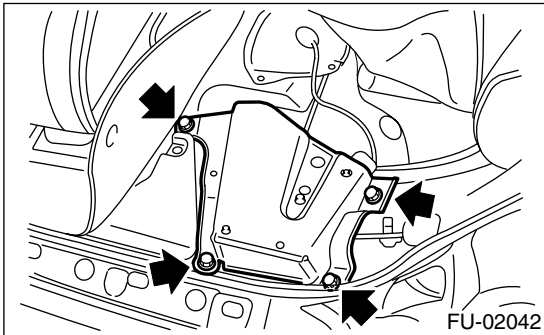

- 4) Disconnect the connector from the fuel pump control unit.
- 5) Remove the fuel pump control unit.

B: INSTALLATION

Install in the reverse order of removal.

FUEL

FUEL INJECTION (FUEL SYSTEMS)

23. Fuel

A: OPERATION

1. RELEASING OF FUEL PRESSURE

WARNING:

- Place “NO FIRE” signs near the working area.
- Be careful not to spill fuel on the floor.

- 1) Disconnect connector from fuel pump relay.

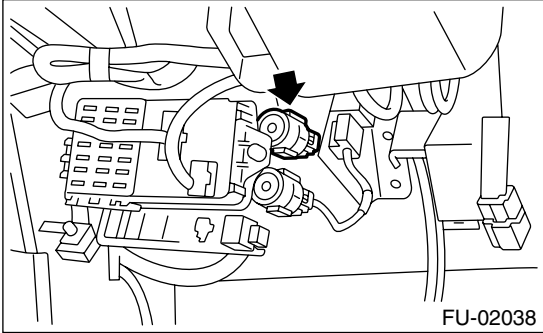

- 2) Start the engine and run it until it stalls.
- 3) After the engine stalls, crank it for five more seconds.
- 4) Turn ignition switch to OFF.

2. DRAINING FUEL

WARNING:

- Place “NO FIRE” signs near the working area.
- Be careful not to spill fuel on the floor.

- 1) Set vehicle on the lift.
- 2) Disconnect battery ground cable.

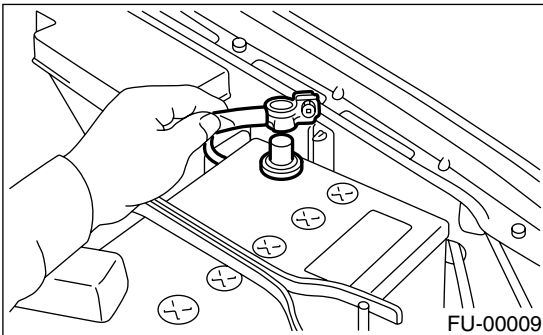

- 3) Lift-up the vehicle.
- 4) Remove front right side fuel tank cover.

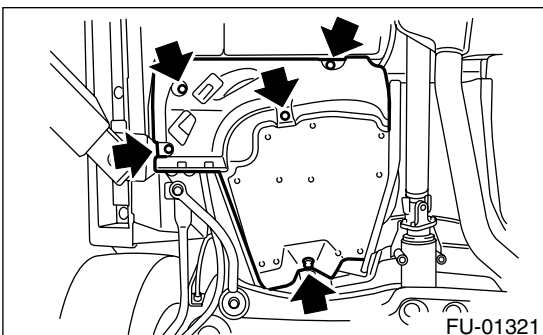

- 5) Drain fuel from fuel tank.
Set a container under the vehicle and remove drain plug from fuel tank.

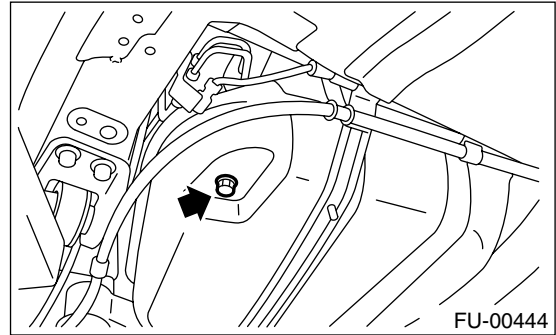

- 6) Tighten fuel drain plug and install front right side tank cover.

NOTE:

Replace gasket with new one.

Tightening torque:

26 N·m (2.65 kgf-m, 19.2 ft-lb)

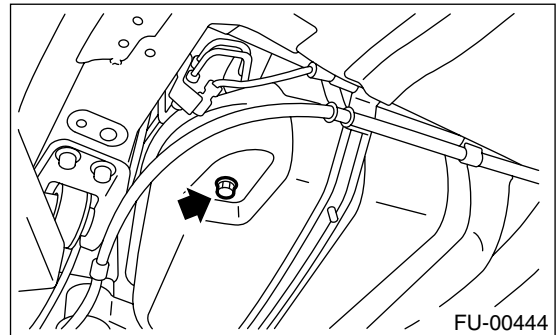

Tightening torque:

18 N·m (1.8 kgf-m, 13.0 ft-lb)

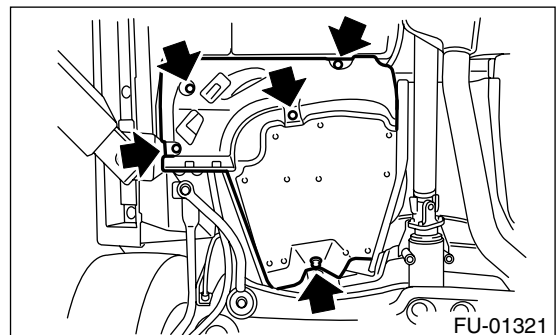

- 7) Lower the vehicle.

FUEL

FUEL INJECTION (FUEL SYSTEMS)

8) Remove sub service hole cover.

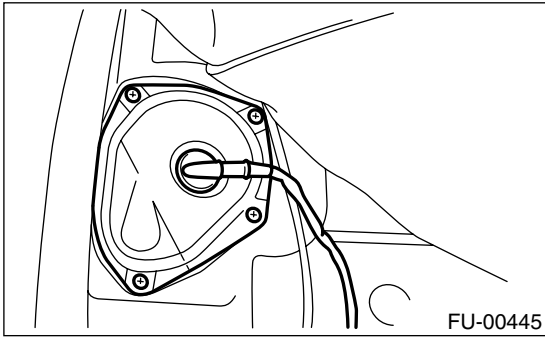

9) Disconnect connector from fuel sub level sensor.

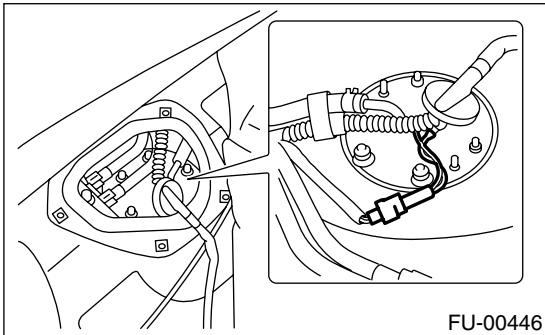

10) Disconnect fuel jet pump hose.

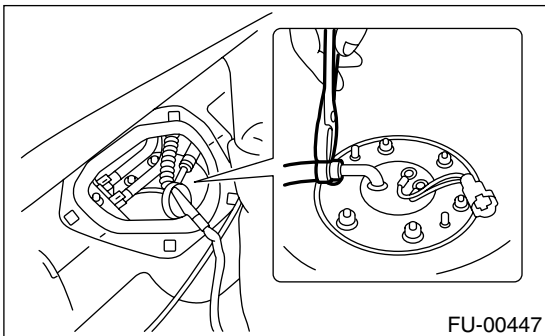

11) Remove fuel sub level sensor.

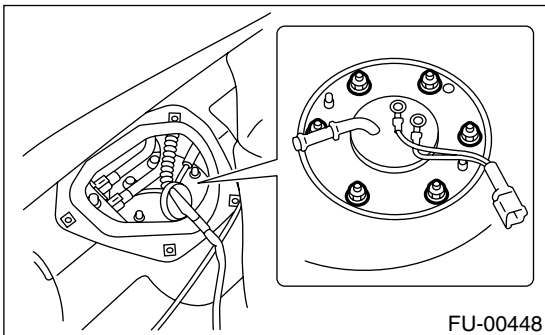

12) Drain fuel from fuel tank by using hand pump.

WARNING:

Do not use a motor pump when draining fuel.

13) After draining fuel, reinstall fuel sub level sensor.

Tightening torque:

T: 4.4 N·m (0.45 kgf·m, 3.3 ft·lb)

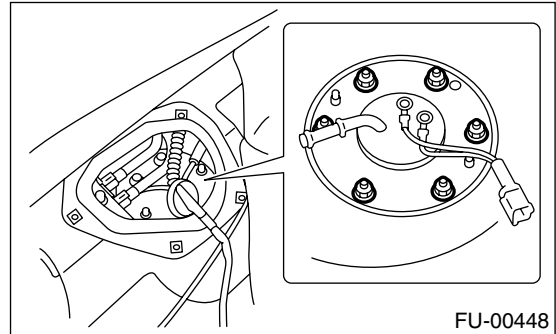

NOTE:

If you have not removed fuel tank yet, proceed with the procedure below for installation.

(1) Connect fuel jet pump hose.

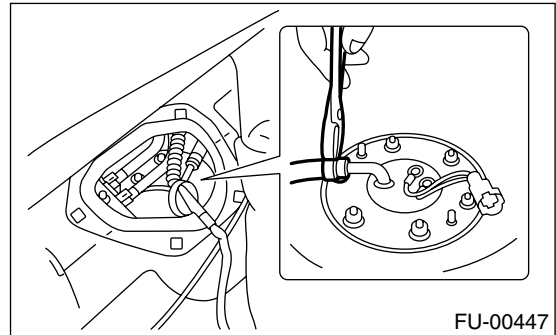

(2) Connect connector from fuel sub level sensor.

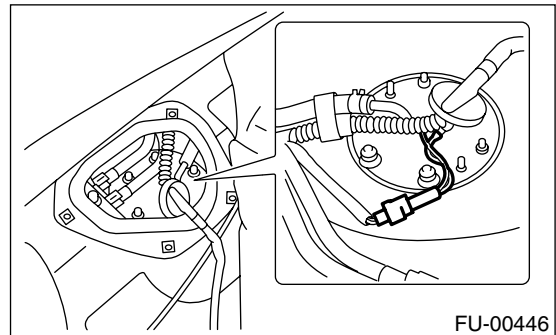

FUEL

FUEL INJECTION (FUEL SYSTEMS)

(3) Install sub service hole cover.

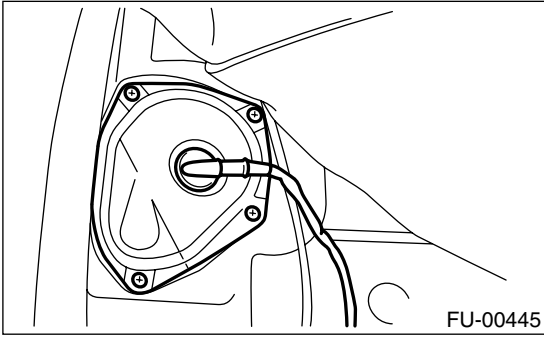

(4) Set rear seat and floor mat.

24. Fuel Tank

A: REMOVAL

- 1) Set vehicle on the lift.
- 2) Release fuel pressure. <Ref. to FU(H4DOTC)-48, RELEASING OF FUEL PRESSURE, OPERATION, Fuel.>
- 3) Drain fuel from fuel tank. <Ref. to FU(H4DOTC)-48, DRAINING FUEL, OPERATION, Fuel.>
- 4) Remove holder clip which secures fuel tank cord on bracket.

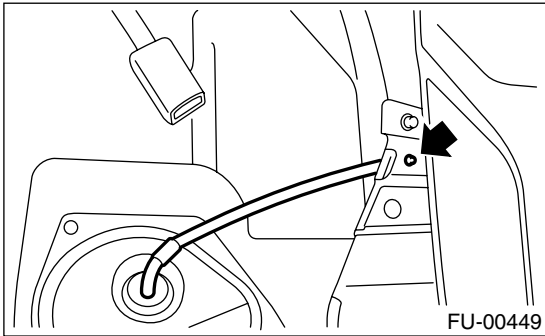

- 5) Disconnect connector of fuel tank cord to rear harness.

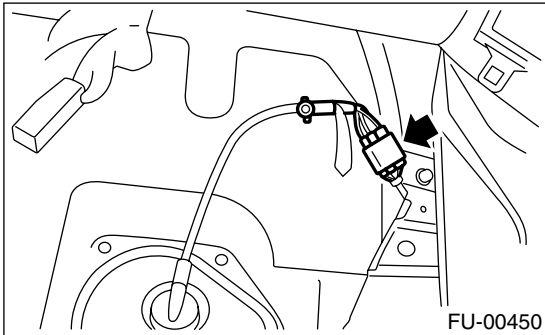

- 6) Push grommet which holds fuel tank cord on service hole cover into body side.

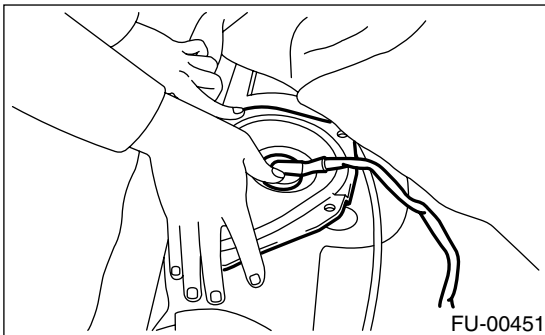

- 7) Separate quick connector of fuel delivery (A) and return hose (B). <Ref. to FU(H4DOTC)-75, REMOVAL, REMOVAL, Fuel Delivery, Return and Evaporation Lines.>

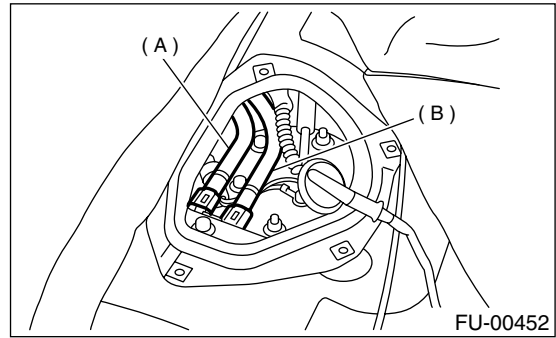

- 8) Remove parking brake cable.
 - (1) Remove console box. <Ref. to EI-45, REMOVAL, Console Box.>
 - (2) Remove parking brake bracket and disconnect parking brake cable from equalizer. <Ref. to PB-6, REMOVAL, Parking Brake Cable.>
- 9) Remove rear pillar trim. <Ref. to EI-69, REMOVAL, Rear Pillar Trim.>
- 10) Remove pipe protector.

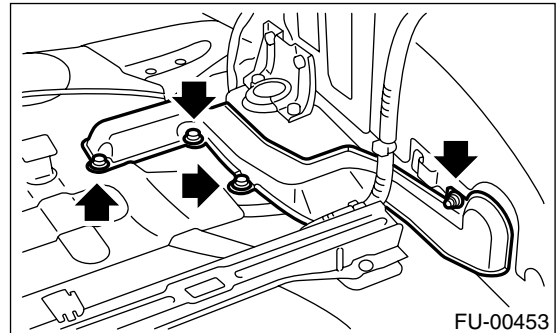

- 11) Separate quick connector of evaporation pipe. <Ref. to FU(H4DOTC)-75, REMOVAL, Fuel Delivery, Return and Evaporation Lines.>

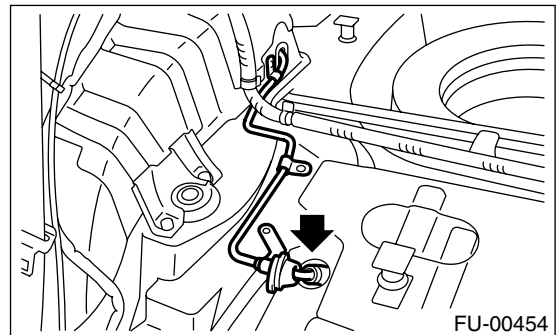

- 12) Remove wheel nuts from rear wheels.
- 13) Lift-up the vehicle.
- 14) Remove rear wheel.

FUEL TANK

FUEL INJECTION (FUEL SYSTEMS)

15) Remove front side fuel tank cover.

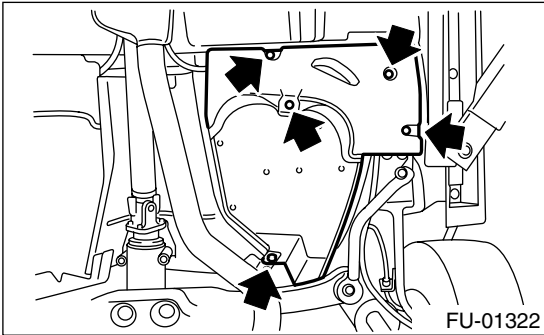
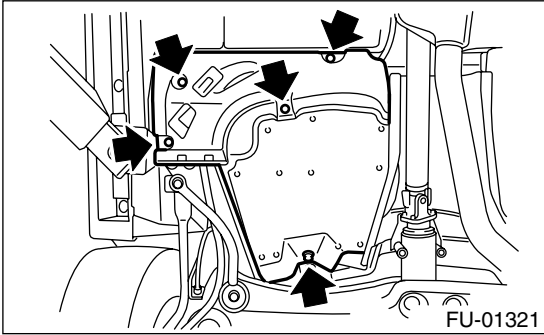

16) Remove rear exhaust pipe and muffler.

NOTE:

To facilitate removal, apply a coat of SUBARU CRC to matching area of rubber cushions in advance.

SUBARU CRC (Part No. 004301003)

(1) Separate rear exhaust pipe from center exhaust pipe.

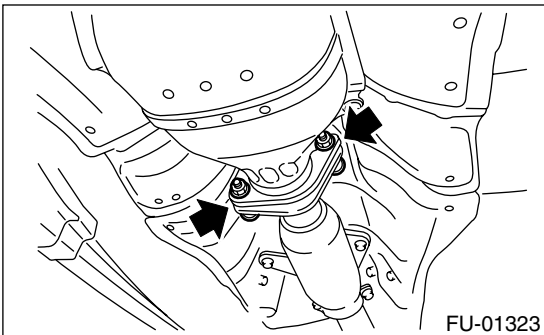

(2) Remove left and right rubber cushions.

CAUTION:

Be careful not to pull down muffler.

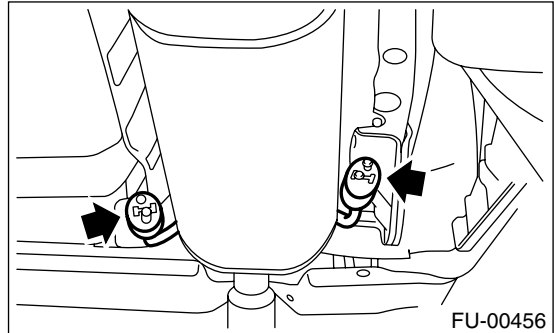

(3) Remove front rubber cushion and detach muffler assembly.

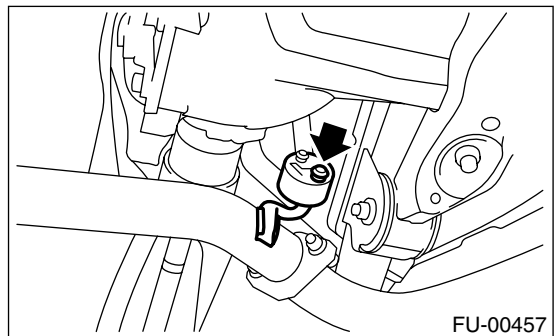

17) Remove propeller shaft. <Ref. to DS-15, REMOVAL, Propeller Shaft.>

18) Disconnect connector from ABS sensor.

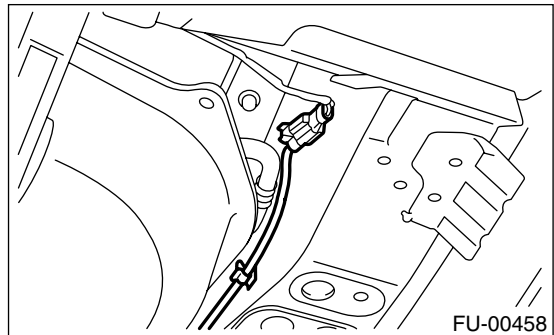

19) Remove bolts which hold parking brake cable holding bracket.

20) Remove parking brake cable from cabin by forcibly pulling it backward.

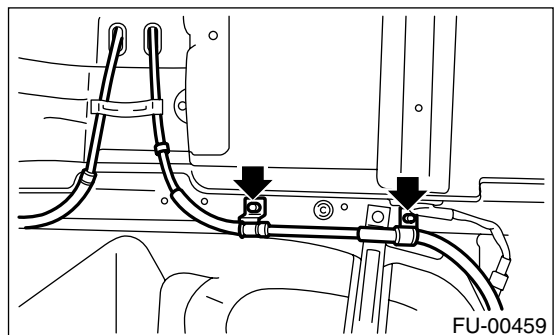

FUEL TANK

FUEL INJECTION (FUEL SYSTEMS)

21) Remove bolts which hold parking brake cable holding bracket.

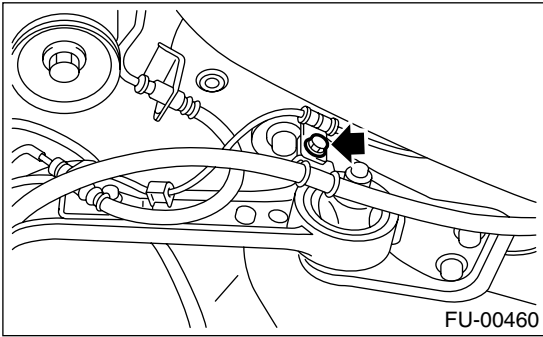

(2) Remove bolt which holds rear shock absorber to rear suspension arm.

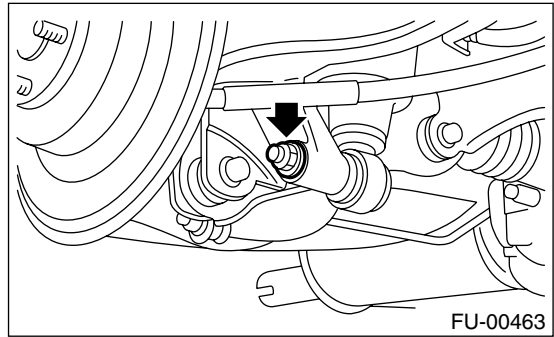

22) Remove bolts which hold rear brake hoses holding bracket.

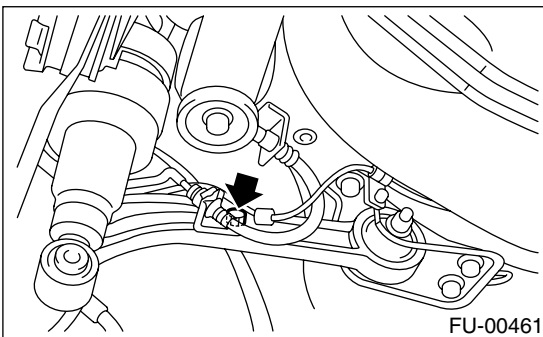

(3) Remove bolts which secure rear suspension assembly to body.

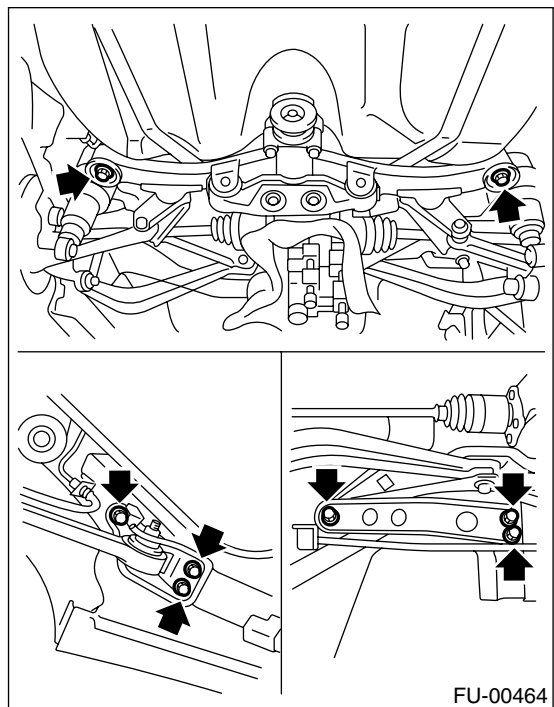

23) Remove rear brake caliper, then tie it up to the body side of the vehicle as shown in figure.

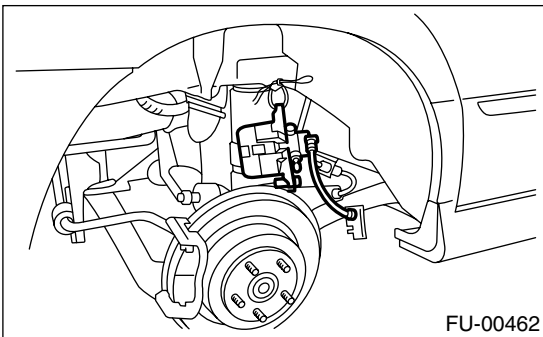

(4) Remove rear suspension assembly.
25) Remove rear side fuel tank cover.

24) Remove rear suspension assembly.

WARNING:

A helper is required to perform this work.

(1) Support rear differential with transmission jack.

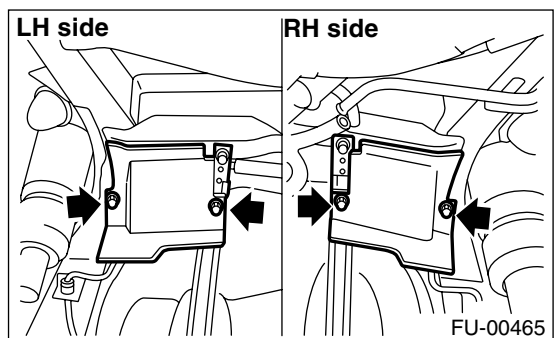

FUEL TANK

FUEL INJECTION (FUEL SYSTEMS)

26) Disconnect fuel filler hose (A) and fuel tank pressure sensor hose (B).

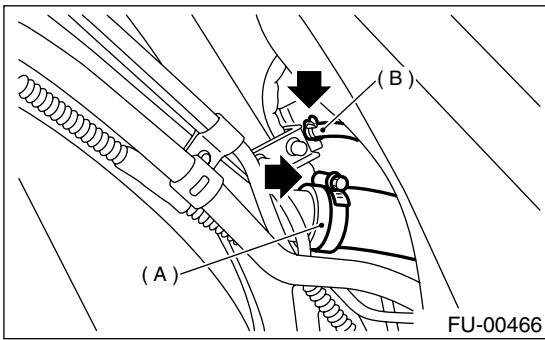

27) Disconnect air vent hose (A) from evaporation pipe assembly and disconnect evaporation hose (H) from pressure control solenoid valve.

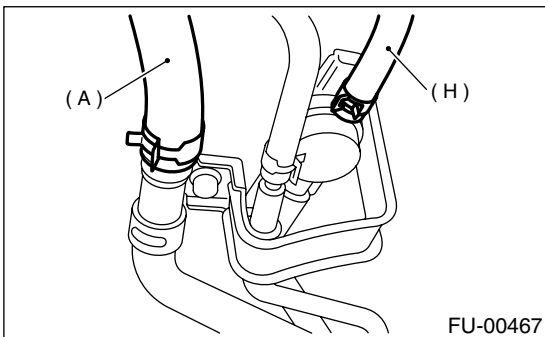

28) Support fuel tank with transmission jack, remove bolts from bands and dismount fuel tank from the vehicle.

WARNING:
A helper is required to perform this work.

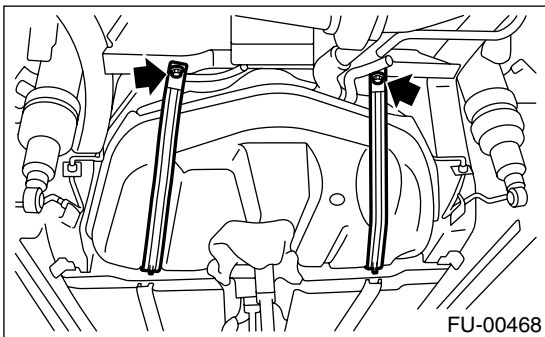

B: Installation

1) Support fuel tank with transmission jack and push fuel tank harness into access hole with grommet.

2) Set fuel tank and temporarily tighten bolts of fuel tank bands.

WARNING:
A helper is required to perform this work.

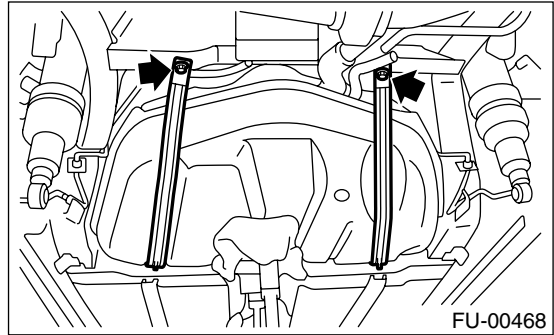

3) Connect air vent hose (A) to evaporation pipe assembly and connect evaporation hose (H) to pressure control solenoid valve.

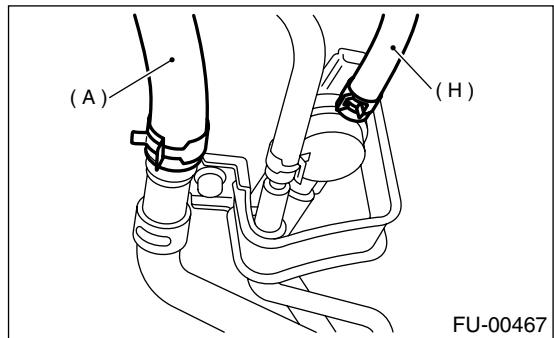

4) Connect fuel filler hose (A) and fuel tank pressure sensor hose (B).

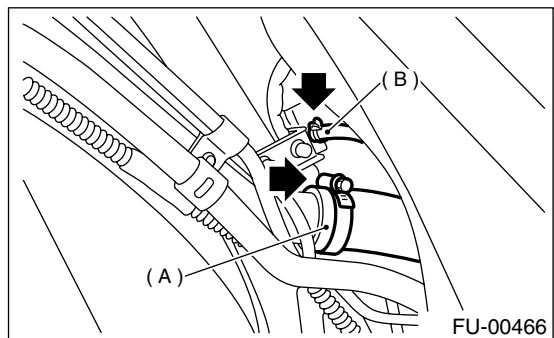

FUEL TANK

FUEL INJECTION (FUEL SYSTEMS)

5) Tighten band mounting bolts.

Tightening torque:

33 N·m (3.4 kgf·m, 25 ft·lb)

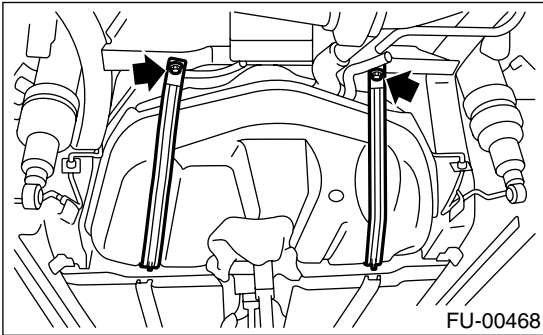

6) Install rear side fuel tank cover.

Tightening torque:

18 N·m (1.8 kgf·m, 13.0 ft·lb)

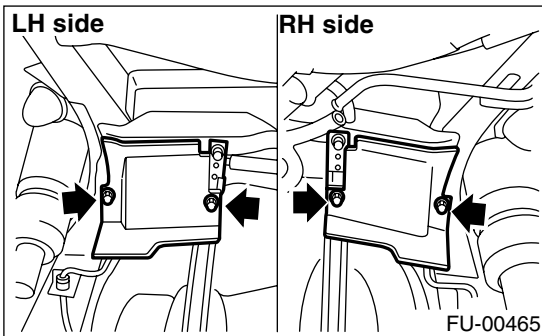

7) Install rear suspension assembly.

WARNING:

A helper is required to perform this work.

(1) Support rear suspension assembly and then tighten bolts which secure rear suspension assembly.

Tightening torque:

T1: 172 N·m (17.5 kgf·m, 127 ft·lb)

T2: 108 N·m (11.0 kgf·m, 80 ft·lb)

T3: 66 N·m (6.7 kgf·m, 48 ft·lb)

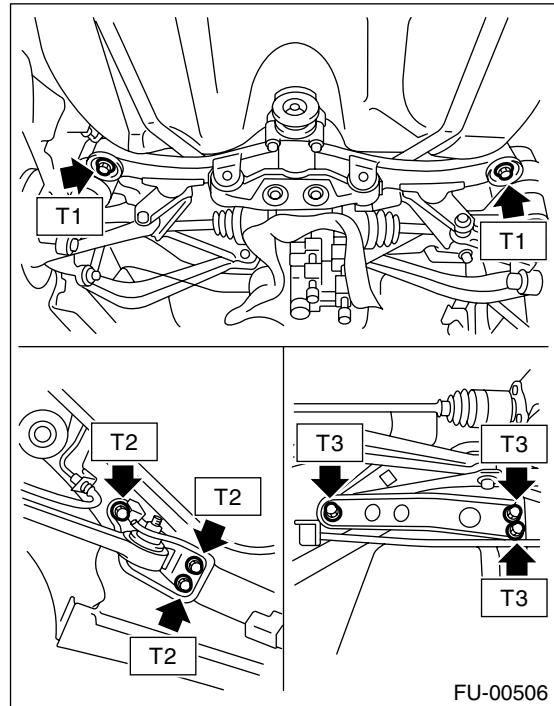

(2) Tighten bolt which holds rear shock absorber to rear suspension arm. <Ref. to RS-14, INSTALLATION, Link Upper.>

Tightening torque:

157 N·m (16 kgf·m, 116 ft·lb)

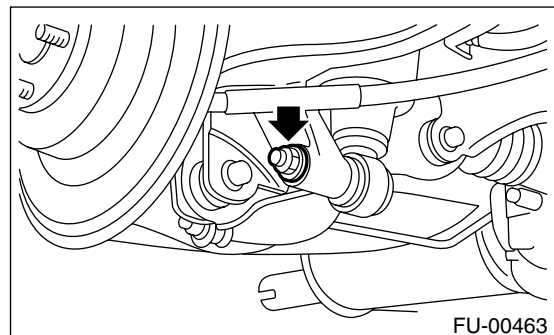

FUEL TANK

FUEL INJECTION (FUEL SYSTEMS)

8) Install rear brake caliper. <Ref. to BR-22, INSTALLATION, Rear Disc Brake Assembly.>

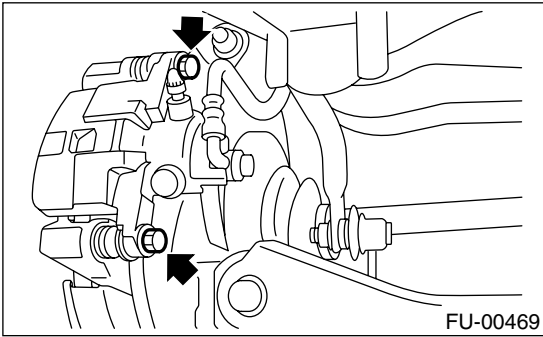

9) Tighten bolts which hold rear brake hoses holding bracket.

Tightening torque:

33 N·m (3.4 kgf·m, 25 ft·lb)

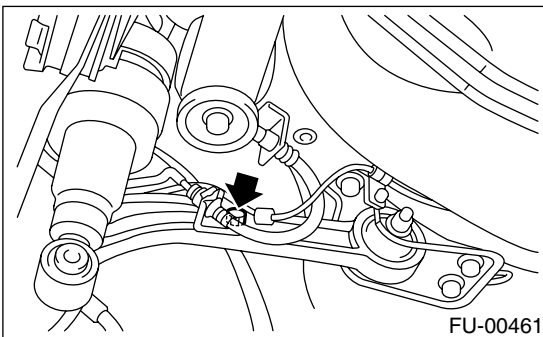

10) Install parking brake cable to cabin by forcibly pushing it forward.

11) Tighten bolts which hold parking brake cable holding bracket.

Tightening torque:

18 N·m (1.8 kgf·m, 13.0 ft·lb)

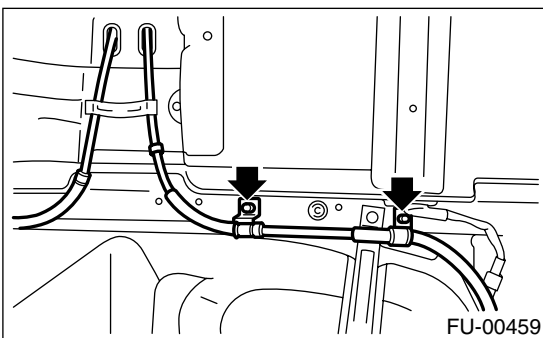

Tightening torque:

32 N·m (3.3 kgf·m, 23.9 ft·lb)

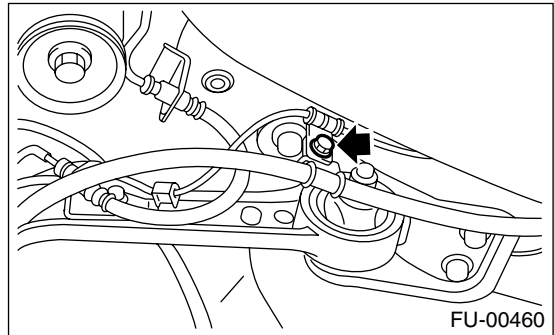

12) Connect connector to ABS sensor.

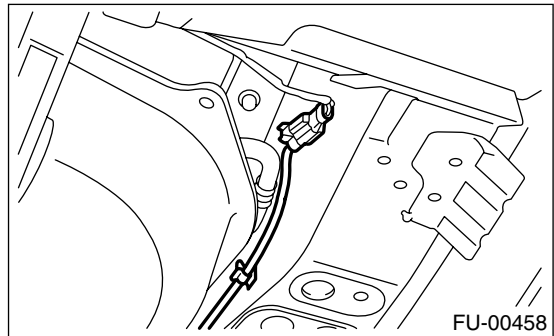

13) Install propeller shaft. <Ref. to DS-16, INSTALLATION, Propeller Shaft.>

14) Install rear exhaust pipe and muffler.

NOTE:

To facilitate the procedure, apply a coat of SUBARU CRC to matching area of rubber cushions in advance.

SUBARU CRC (Part No. 004301003)

(1) Install left and right rubber cushions.

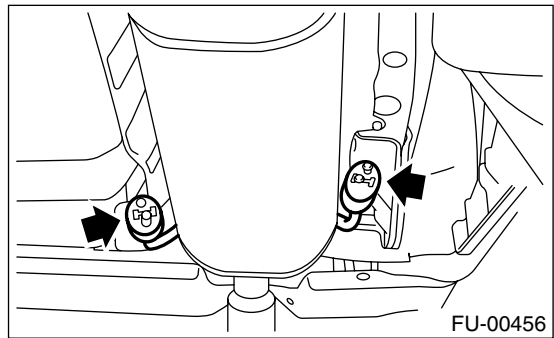

FUEL TANK

FUEL INJECTION (FUEL SYSTEMS)

- (2) Install front rubber cushion and attach muffler assembly.

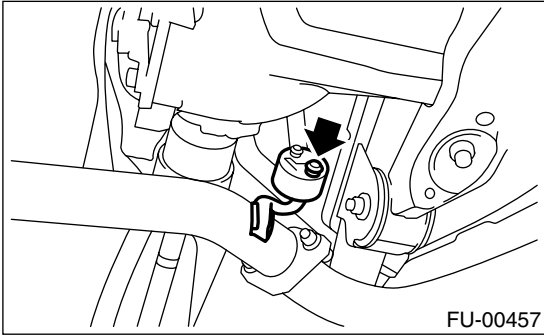

- (3) Install rear exhaust pipe to center exhaust pipe.

Tightening torque:

18 N·m (1.8 kgf-m, 13.0 ft-lb)

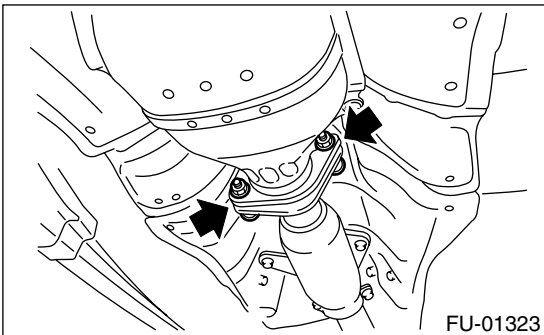

- 15) Install front side fuel tank cover.

Tightening torque:

18 N·m (1.8 kgf-m, 13.0 ft-lb)

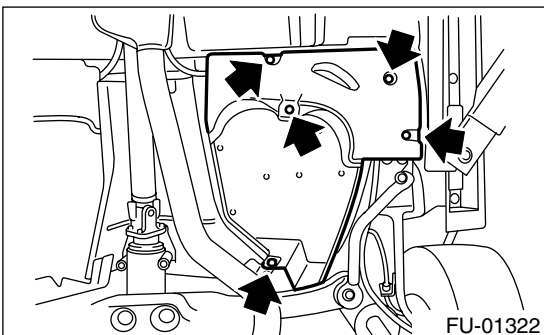
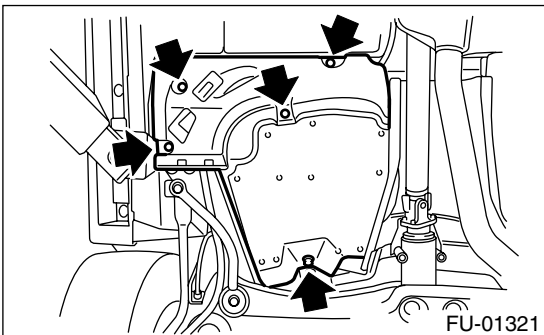

- 16) Install rear wheel.
17) Lower the vehicle.
18) Tighten wheel nuts to rear wheel.
19) Install parking brake cable. <Ref. to PB-5, INSTALLATION, Parking Brake Lever.>
20) Install console box. <Ref. to EI-45, INSTALLATION, Console Box.>
21) Connect fuel hoses and hold them with quick connector. <Ref. to FU(H4DOTC)-76, INSTALLATION, Fuel Delivery, Return and Evaporation Lines.>

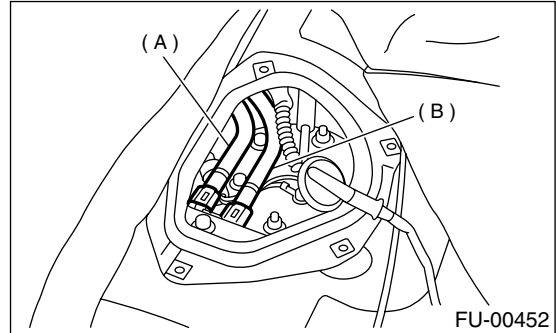

- (A) Delivery hose
(B) Return hose

- 22) Connect evaporation pipe and hold it with quick connector. <Ref. to FU(H4DOTC)-76, INSTALLATION, Fuel Delivery, Return and Evaporation Lines.>

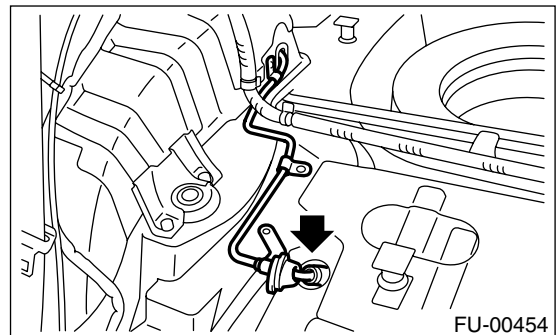

- 23) Install pipe protector.

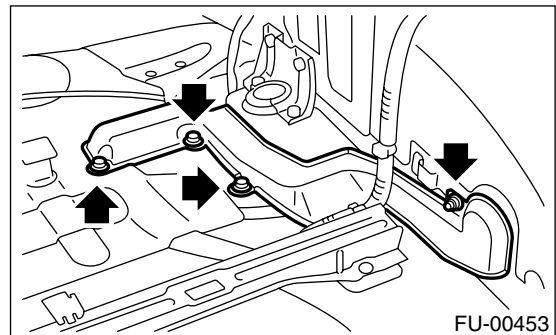

- 24) Install rear pillar trim. <Ref. to EI-69, REMOVAL, Rear Pillar Trim.>

FUEL TANK

FUEL INJECTION (FUEL SYSTEMS)

25) Connect fuel jet pump hose.

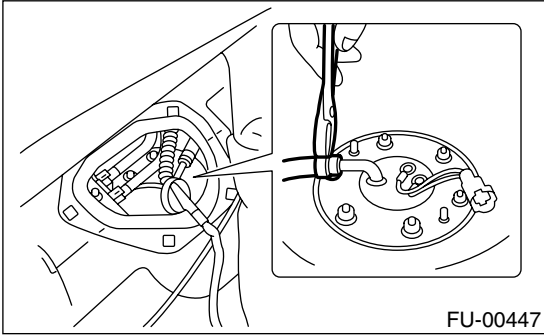

26) Connect connector to fuel sub level sensor.

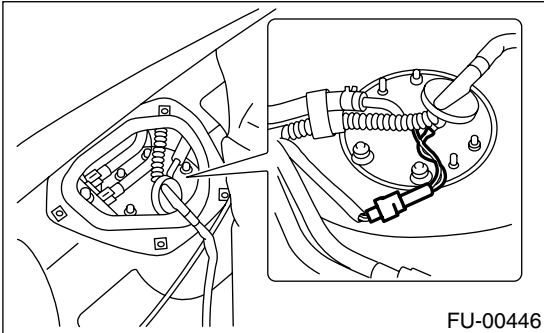

27) Install sub service hole cover.

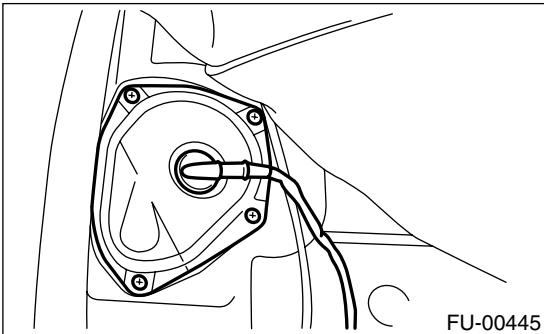

28) Connect connectors to fuel tank cord and plug service hole with grommet.

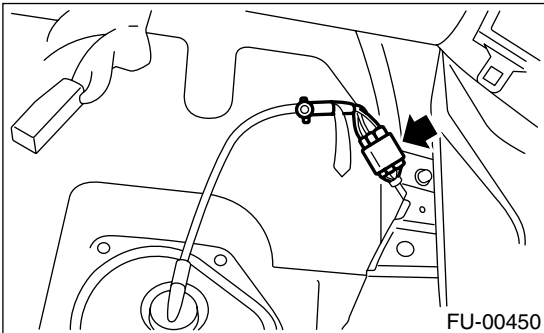

29) Install holder clip which secures fuel tank cord on bracket.

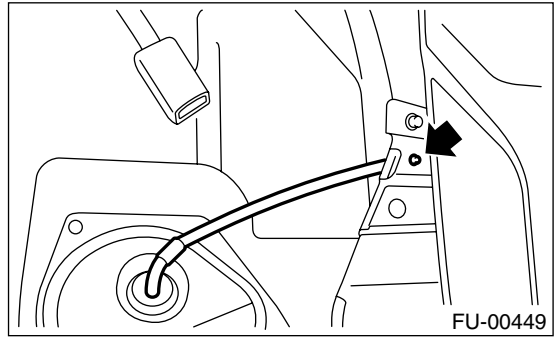

30) Set rear seat and floor mat.

31) Connect connector to fuel pump relay.

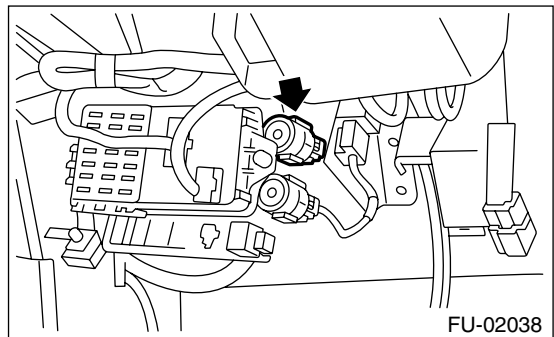

32) Adjust parking brake lever stroke. <Ref. to PB-5, ADJUSTMENT, Parking Brake Lever.>

33) Check wheel alignment and adjust if necessary. <Ref. to FS-6, INSPECTION, Wheel Alignment.>

C: INSPECTION

1) Make sure there are no cracks, holes, or other damage on the fuel tank.

2) Make sure that the fuel hoses and fuel pipes are not cracked and that connections are tight.

25. Fuel Filler Pipe

A: REMOVAL

WARNING:

- Place “NO FIRE” signs near the working area.
- Be careful not to spill fuel on the floor.

- 1) Set the vehicle on the lift.
- 2) Disconnect battery ground cable.

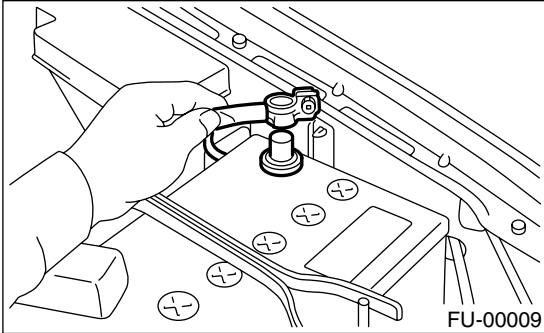

- 3) Open fuel filler flap lid and remove filler cap.
- 4) Remove screws holding packing in place.

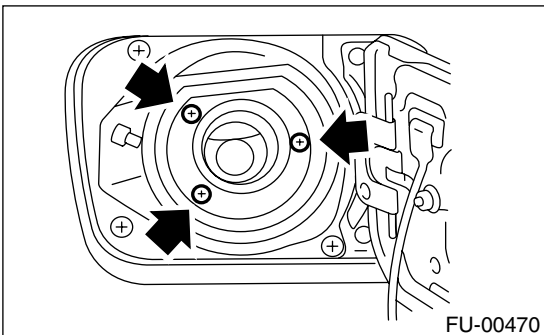

- 5) Lift-up the vehicle.
- 6) Remove rear wheel nuts.
- 7) Remove rear wheel.

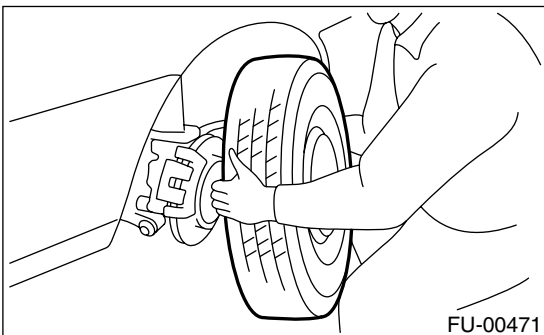

- 8) Remove front right side fuel tank cover.

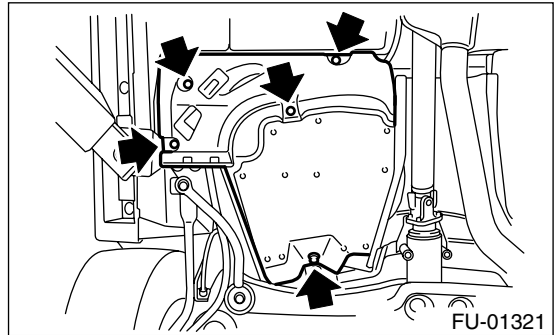

- 9) Drain fuel from fuel tank. Set a container under the vehicle and remove drain plug from fuel tank.

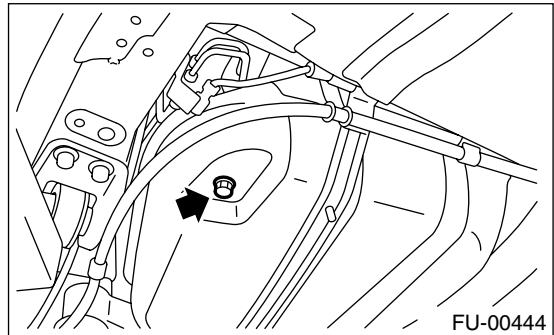

- 10) Tighten fuel drain plug and then install front right side tank cover.

NOTE:

Replace gasket with new one.

Tightening torque:

26 N·m (2.65 kgf-m, 19.2 ft-lb)

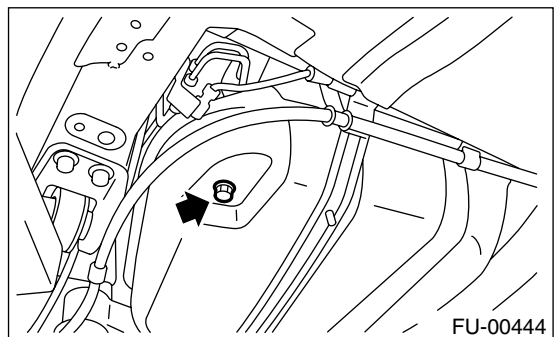

FUEL FILLER PIPE

FUEL INJECTION (FUEL SYSTEMS)

Tightening torque:

18 N·m (1.8 kgf-m, 13.0 ft-lb)

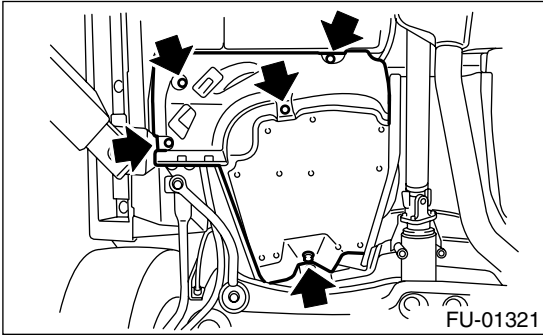

11) Remove rear exhaust pipe and muffler.

NOTE:

To facilitate removal, apply a coat of SUBARU CRC to matching area of rubber cushions in advance.

SUBARU CRC (Part No. 004301003)

(1) Separate rear exhaust pipe from center exhaust pipe.

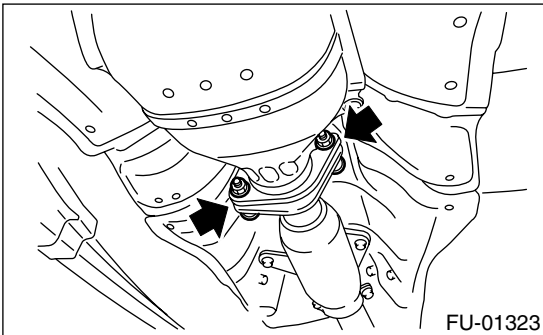

(2) Remove left and right rubber cushions.

CAUTION:

Be careful not to pull down muffler.

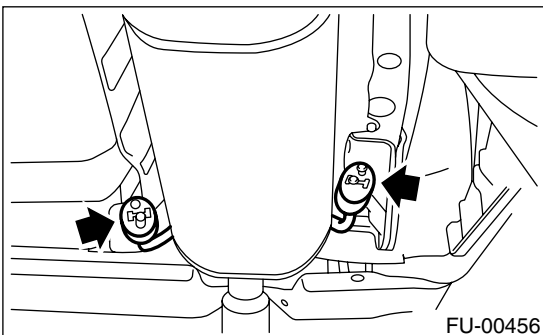

(3) Remove front rubber cushion and detach muffler assembly.

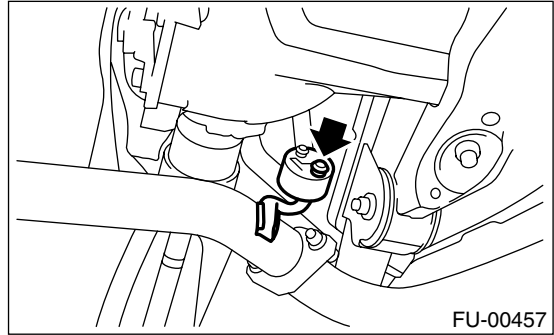

12) Remove heat sealed cover.

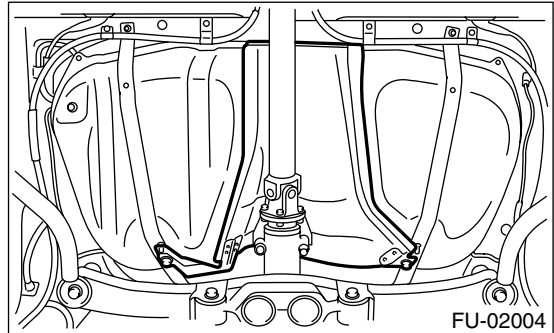

13) Place transmission jack under sub frame.

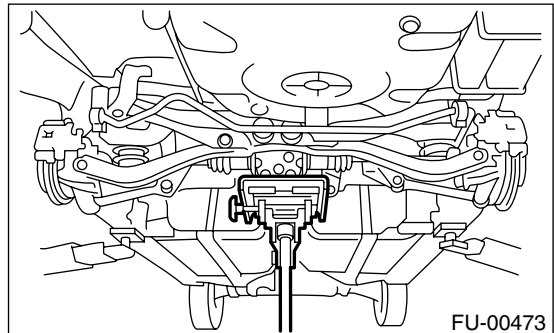

14) Remove bolt which holds rear shock absorber to rear suspension arm.

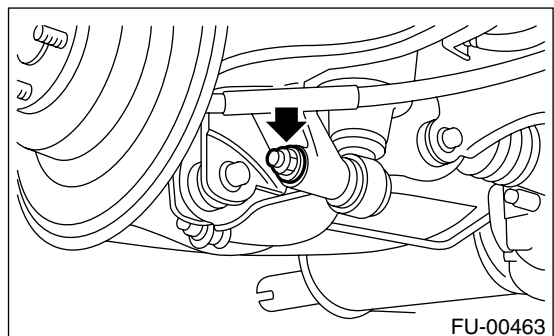

FUEL FILLER PIPE

FUEL INJECTION (FUEL SYSTEMS)

15) Remove bolts which hold rear sub frame on body.

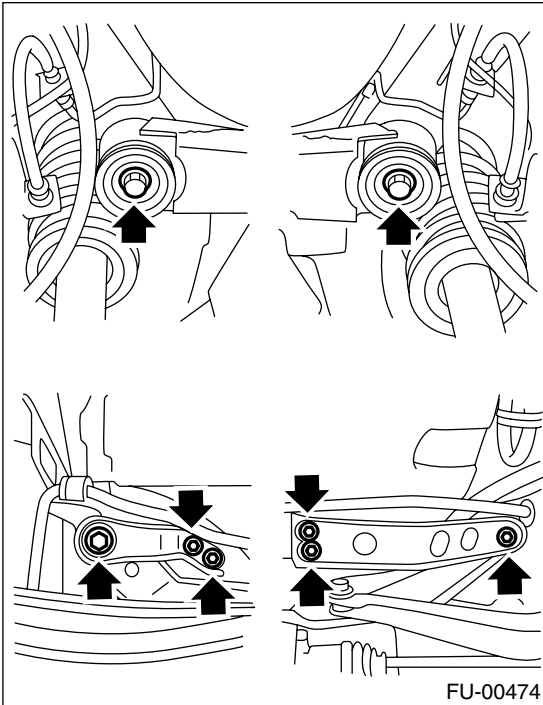

16) Lower the rear sub frame.

CAUTION:

Be sure to lower sub frame slowly.

A = 150 mm (5.91 in)

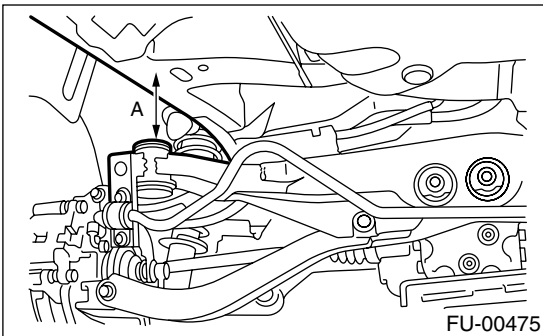

17) Remove fuel filler pipe protector.

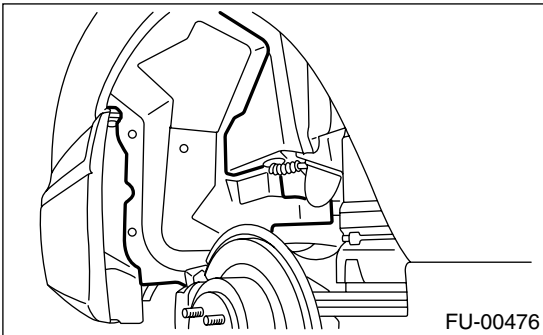

18) Disconnect air vent hose (A) and evaporation hose (P) from evaporation pipe assembly.

19) Disconnect evaporation hose (H) from pressure control solenoid valve.

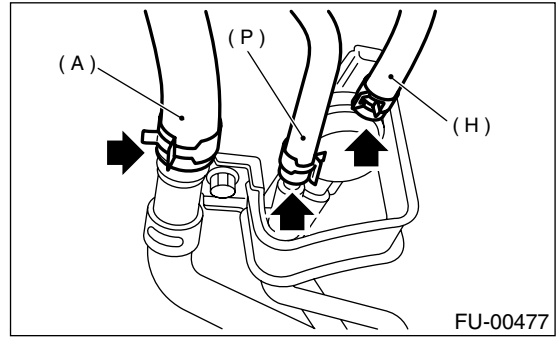

20) Remove bolt which holds evaporation pipe assembly on body.

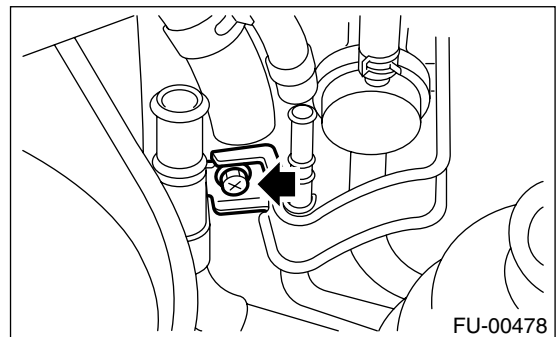

21) Disconnect fuel filler hose.

22) Remove bolt which holds fuel pressure sensor on fuel filler pipe and remove bolt which holds fuel filler pipe on body.

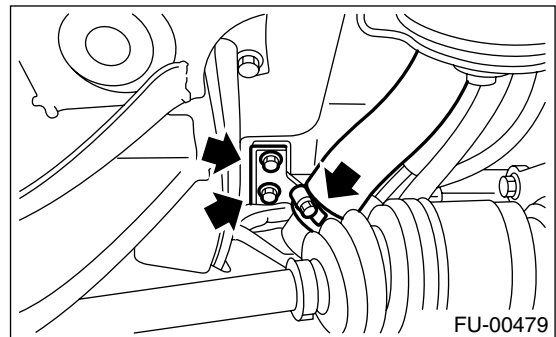

23) Disconnect canister hose from evaporation pipe assembly.

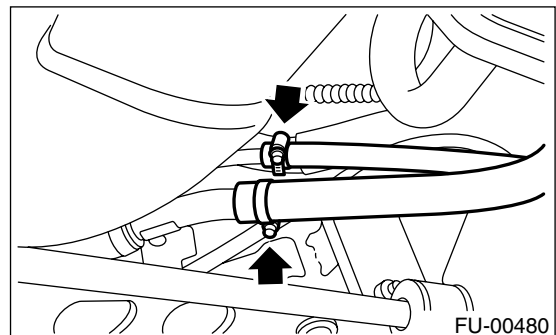

FUEL FILLER PIPE

FUEL INJECTION (FUEL SYSTEMS)

24) Disconnect evaporation hose (O) from fuel filler pipe.

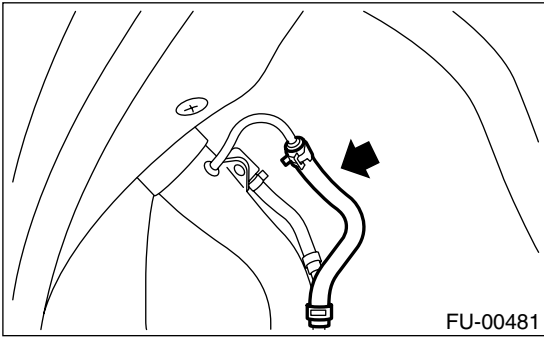

25) Remove bolt which holds fuel filler pipe to body.

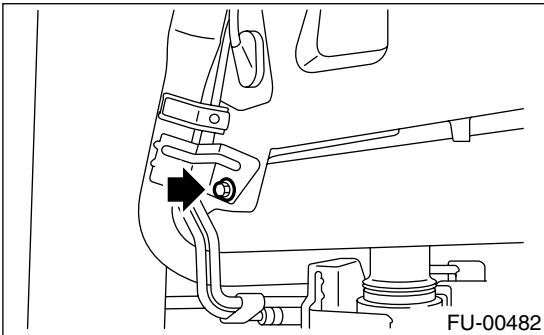

26) Remove fuel filler pipe from under side of the vehicle.

B: Installation

1) Hold fuel filler flap open.

2) Set fuel saucer (A) with rubber packing (C) and insert fuel filler pipe into hole from the inner side of apron.

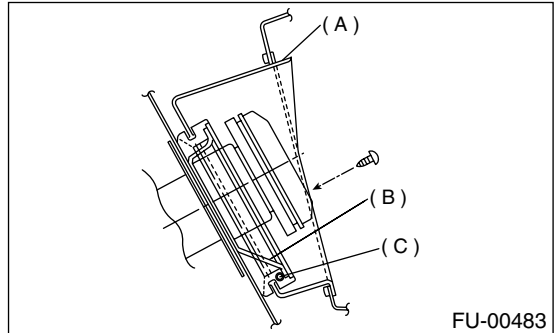

3) Align holes in fuel filler pipe neck and set cup (B), and tighten screws.

NOTE:

If edges of rubber packing are folded toward the inside, straighten it with a screwdriver.

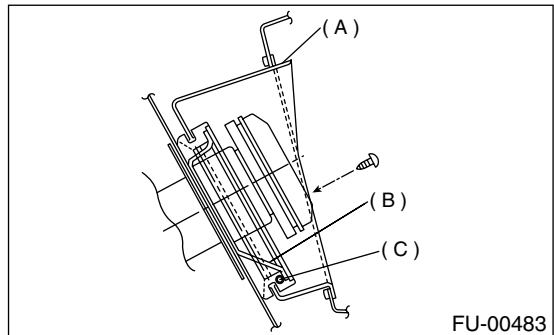

4) Tighten bolt which holds fuel filler pipe on body.

Tightening torque:

7.5 N·m (0.75 kgf-m, 5.4 ft-lb)

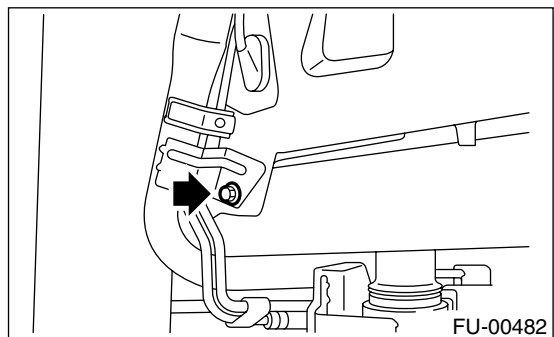

FUEL FILLER PIPE

FUEL INJECTION (FUEL SYSTEMS)

5) Insert evaporation hose approximately 25 to 30 mm (0.98 to 1.18 in) into the lower end of evaporation pipe and hold clip.

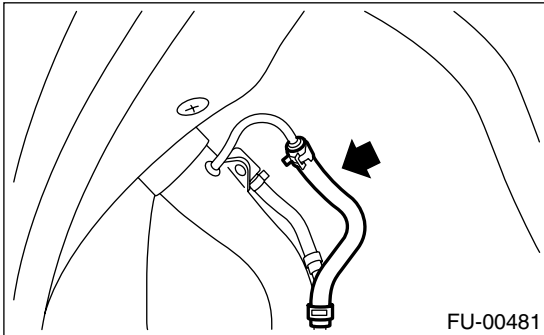

$L = 27.5 \pm 2.5 \text{ mm (1.083 \pm 0.098 in)}$

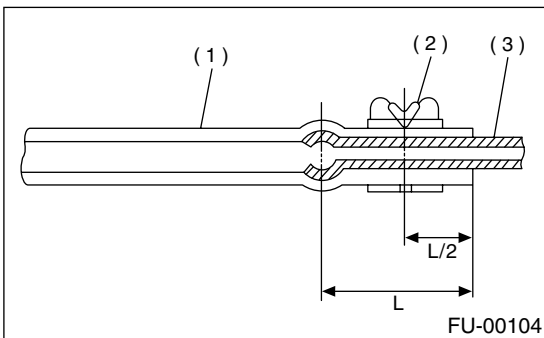

- (1) Hose
- (2) Clip
- (3) Pipe

6) Insert canister hoses approximately 25 to 30 mm (0.98 to 1.18 in) into the lower end of evaporation pipe assembly and tighten clamp.

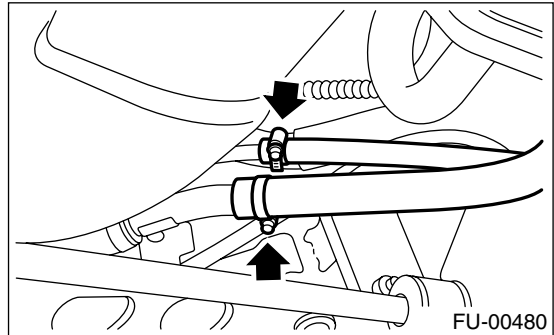

$L = 27.5 \pm 2.5 \text{ mm (1.083 \pm 0.098 in)}$

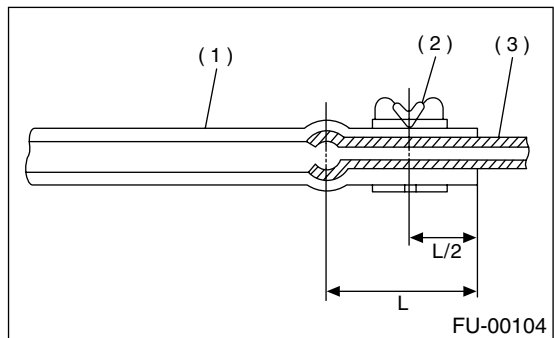

- (1) Hose
- (2) Clip
- (3) Pipe

7) Tighten bolt which holds evaporation pipe assembly on body.

Tightening torque:

7.5 N·m (0.75 kgf-m, 5.4 ft-lb)

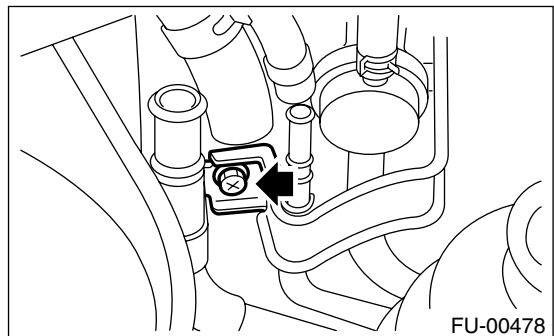

8) Insert air vent hose (A), evaporation hose (P) approximately 25 to 30 mm (0.98 to 1.18 in) into the lower end of evaporation pipe assembly and hold clip.

FUEL FILLER PIPE

FUEL INJECTION (FUEL SYSTEMS)

9) Insert evaporation hose (H) to pressure control solenoid valve and hold clip.

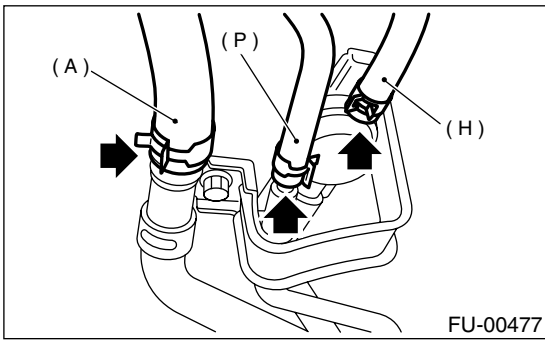

$L = 27.5 \pm 2.5 \text{ mm (1.083 \pm 0.098 in)}$

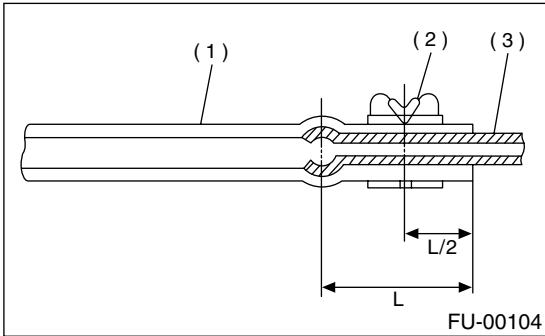

- (1) Hose
- (2) Clip
- (3) Pipe

10) Tighten bolt which holds fuel filler pipe on body and tighten bolt which holds fuel pressure sensor on fuel filler pipe.

Tightening torque:

7.5 N·m (0.75 kgf-m, 5.4 ft-lb)

11) Insert fuel filler hose approximately 35 to 40 mm (1.38 to 1.57 in) over the lower end of fuel filler pipe and tighten clamp.

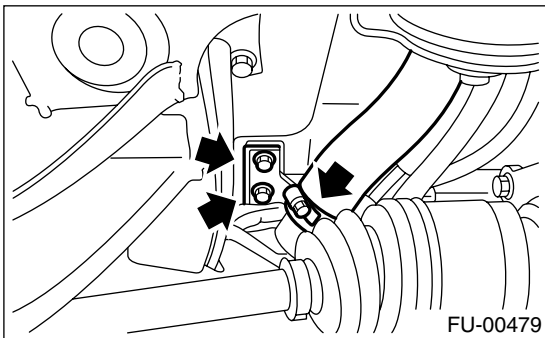

12) Jack-up the rear sub frame and tighten bolts which hold rear sub frame on body.

Tightening torque:

T1: 66 N·m (6.7 kgf-m, 48.5 ft-lb)

T2: 172 N·m (17.5 kgf-m, 127 ft-lb)

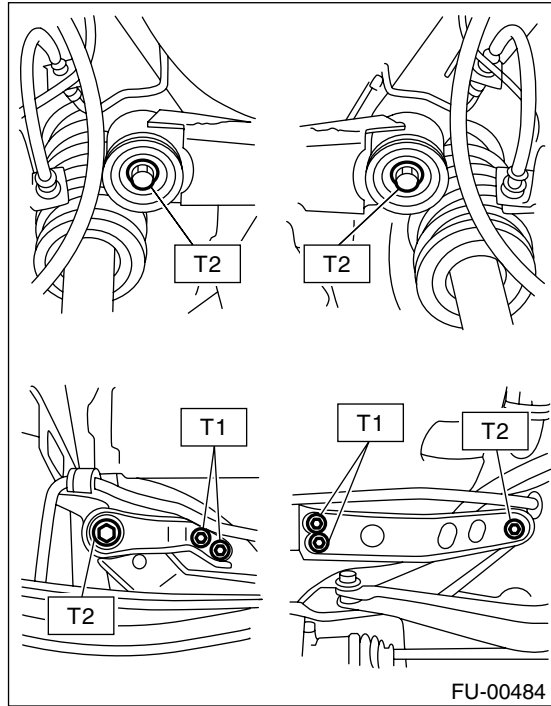

13) Tighten bolt which holds rear shock absorber to rear suspension arm. <Ref. to RS-17, INSTALLATION, Rear Shock Absorber.>

Tightening torque:

157 N·m (16 kgf-m, 116 ft-lb)

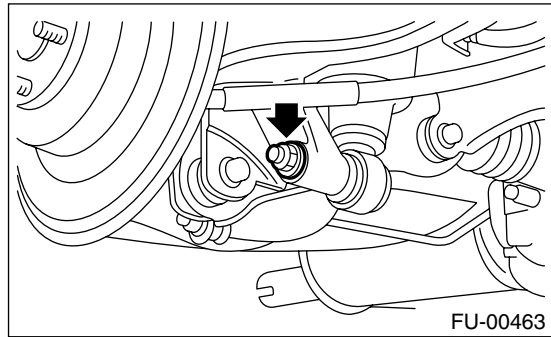

FUEL FILLER PIPE

FUEL INJECTION (FUEL SYSTEMS)

14) Install heat shield cover.

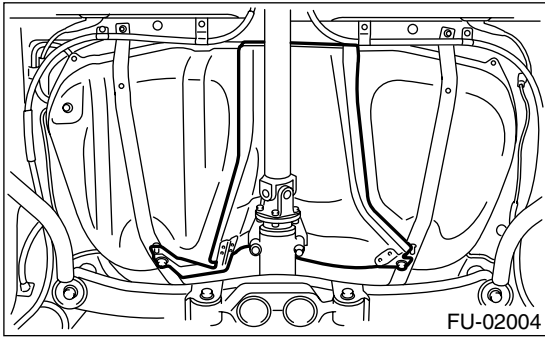

15) Install rear exhaust pipe and muffler.

NOTE:

To facilitate the procedure, apply a coat of SUBARU CRC to matching area of rubber cushions in advance.

SUBARU CRC (Part No. 004301003)

(1) Install left and right rubber cushions.

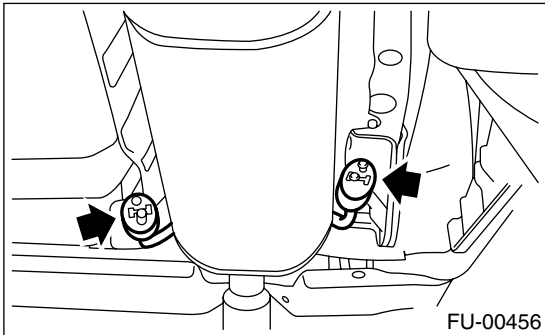

(2) Install front rubber cushion and attach muffler assembly.

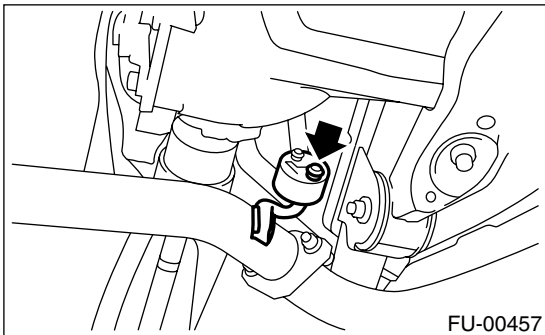

(3) Install rear exhaust pipe to center exhaust pipe.

Tightening torque:

18 N·m (1.8 kgf-m, 13.0 ft-lb)

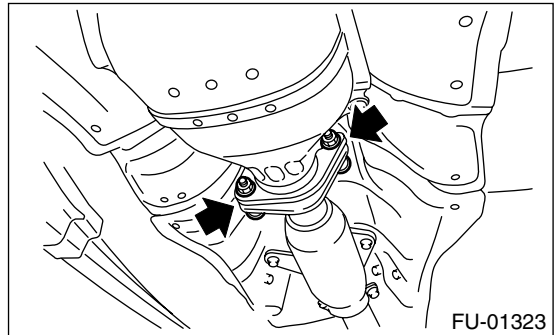

16) Install fuel filler pipe protector.

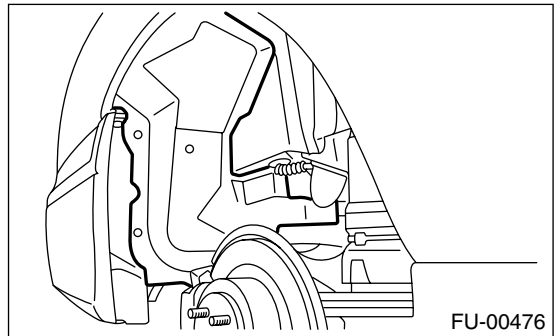

17) Install rear right wheel.

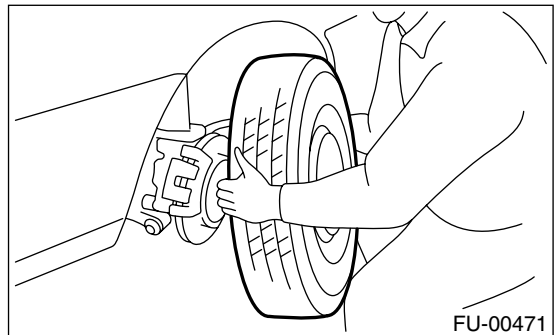

18) Lower the vehicle.

19) Tighten wheel nuts.

20) Connect battery ground cable.

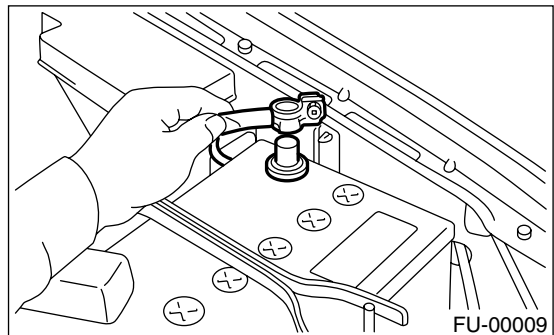

21) Remove fuel filler pipe to under side of the vehicle.

FUEL FILLER PIPE

FUEL INJECTION (FUEL SYSTEMS)

C: DISASSEMBLY

1) Disconnect evaporation hose (L) and (M) from evaporation pipe assembly.

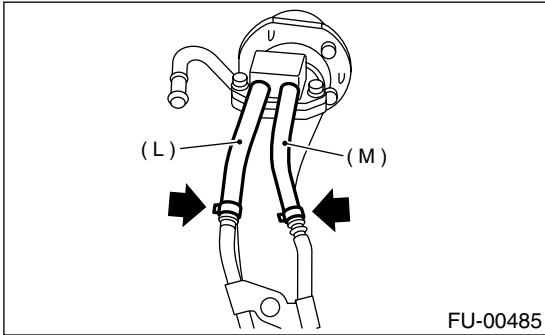

2) Remove shut valve from fuel filler pipe.

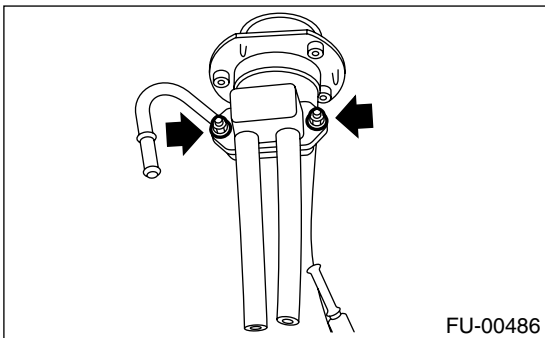

3) Remove nut which holds evaporation pipe assembly on fuel filler pipe.

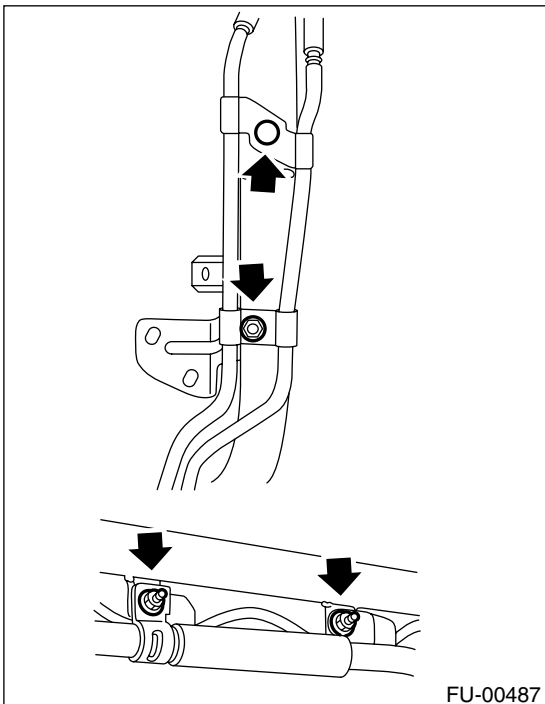

D: ASSEMBLY

Assemble in the reverse order of disassembly.

26. Fuel Pump

A: REMOVAL

WARNING:

- Place “NO FIRE” signs near the working area.
- Be careful not to spill fuel on the floor.
- During work procedures, if fuel tank is more than 3/4 full, be careful because fuel may spill.

NOTE:

Fuel pump assembly consists of fuel pump and fuel level sensor.

- 1) Release fuel pressure. <Ref. to FU(H4DOTC)-48, RELEASING OF FUEL PRESSURE, OPERATION, Fuel.>
- 2) Open fuel filler flap lid and remove fuel filler cap.
- 3) Disconnect battery ground cable.

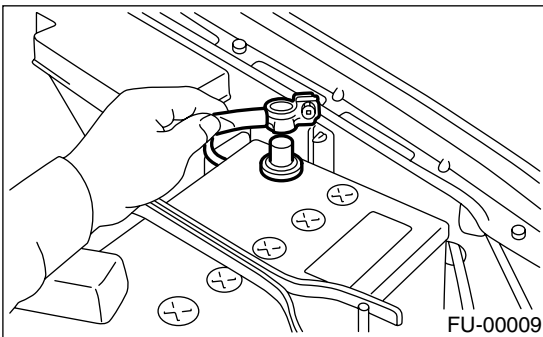

- 4) Lift-up the vehicle.
- 5) Remove front side fuel tank cover.

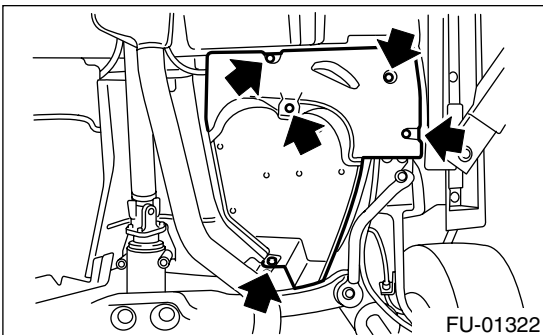
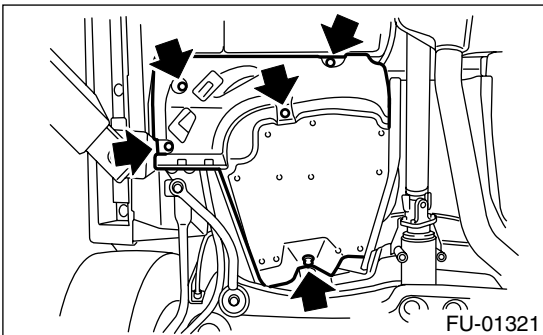

- 6) Drain fuel from fuel tank. Set a container under the vehicle and remove drain plug from fuel tank.

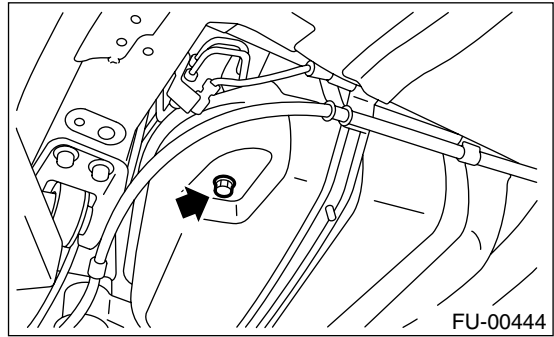

- 7) Tighten fuel drain plug and install front right side fuel tank cover.

NOTE:

Replace gasket with new one.

Tightening torque:

26 N·m (2.65 kgf-m, 19.2 ft-lb)

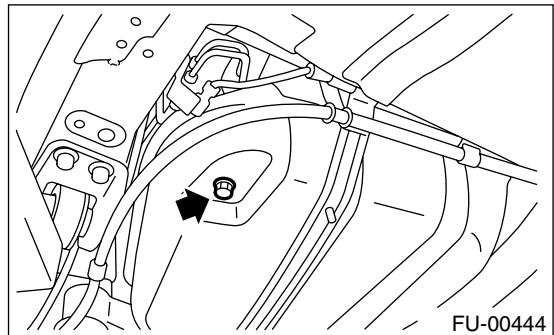

Tightening torque:

18 N·m (1.8 kgf-m, 13.0 ft-lb)

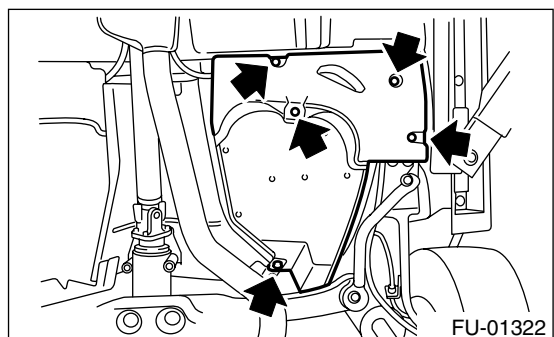
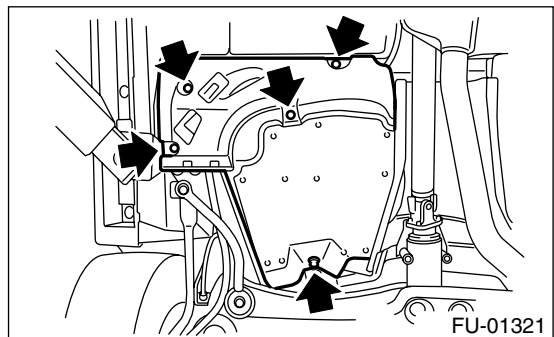

FUEL PUMP

FUEL INJECTION (FUEL SYSTEMS)

- 8) Raise rear seat and turn floor mat up.
- 9) Remove access hole lid.

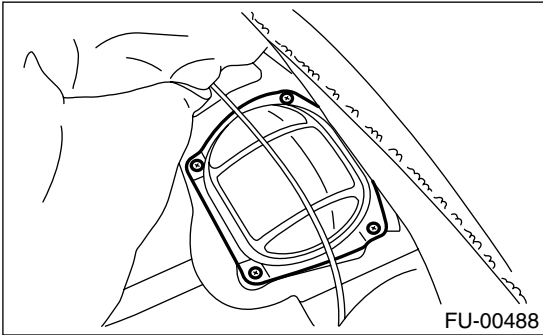

- 10) Disconnect connector from fuel pump.

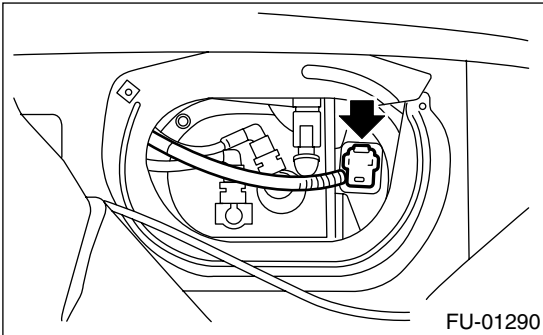

- 11) Move clips and then disconnect jet pump hose (C).
- 12) Disconnect quick connector and then disconnect fuel delivery hose (A) and return hose (B). <Ref. to FU(H4DOTC)-75, REMOVAL, Fuel Delivery, Return and Evaporation Lines.>

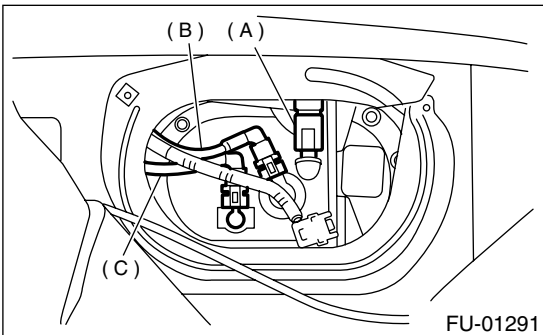

- 13) Remove nuts which install fuel pump assembly onto fuel tank.

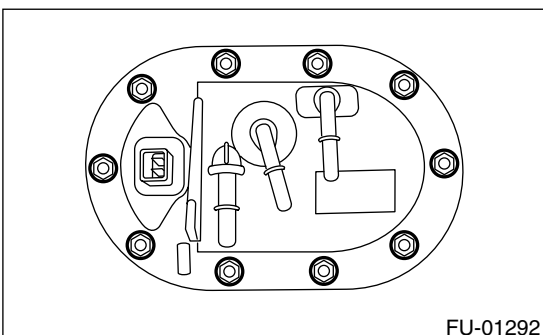

- 14) Take off fuel pump assembly from fuel tank.

B: INSTALLATION

Install in the reverse order of removal. Do the following:

- (1) Always use new gaskets.
- (2) Ensure sealing portion is free from fuel or foreign particles before installation.
- (3) Tighten nuts in alphabetical sequence shown in figure to specified torque.

Tightening torque:

5.9 N·m (0.6 kgf·m, 4.3 ft·lb)

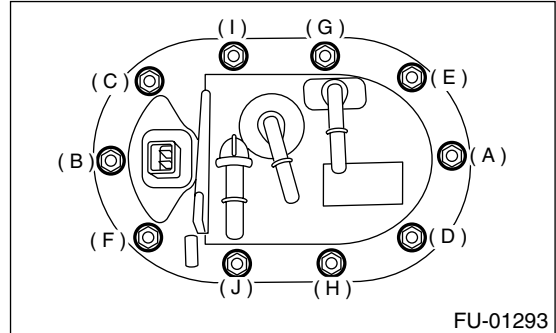

C: Disassembly

- 1) Remove fuel pump and pump holder.

NOTE:

When disassembling pump holder, be careful as it is installed with two pawls.

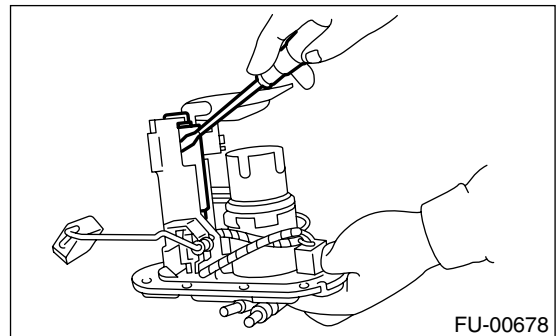

- 2) Disconnect connector from fuel pump.

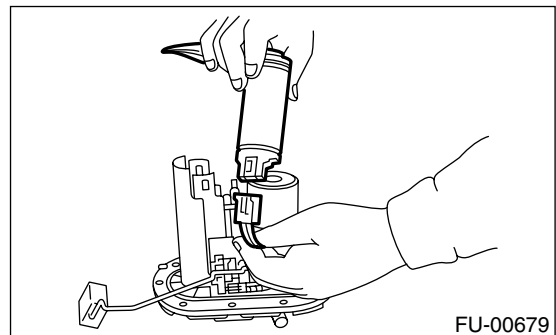

D: ASSEMBLY

Assemble in the reverse order of disassembly.

E: INSPECTION

Connect lead harness to connector terminal of fuel pump and apply battery power supply to check whether the pump operate.

WARNING:

- Wipe off the fuel completely.
- Keep battery as far apart from fuel pump as possible.
- Be sure to turn the battery supply ON and OFF on the battery side.
- Do not run fuel pump for a long time under non-load condition.

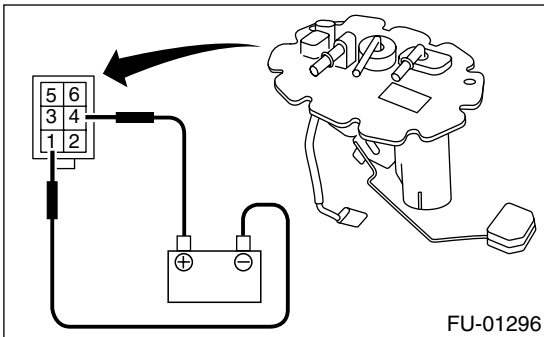

FUEL LEVEL SENSOR

FUEL INJECTION (FUEL SYSTEMS)

27. Fuel Level Sensor

A: REMOVAL

WARNING:

- Place “NO FIRE” signs near the working area.
- Be careful not to spill fuel on the floor.
- During work procedures, if fuel tank is more than 3/4 full, be careful because fuel may spill.

NOTE:

Fuel level sensor is built in fuel pump assembly.

- 1) Remove fuel pump assembly. <Ref. to FU(H4DOTC)-67, REMOVAL, Fuel Pump.>
- 2) Disconnect connector from fuel pump bracket.

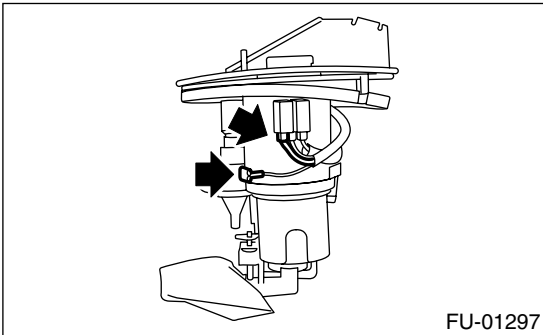

- 3) Pushing the pawls with a screwdriver, remove fuel level sensor by pulling it downwards.

NOTE:

If the retainer pawls are broken during removal, the fuel level sensor must be replaced with a new one.

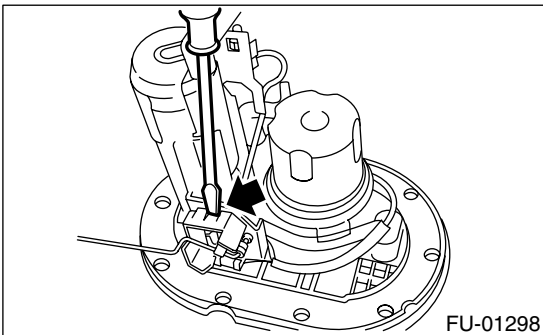

B: Installation

Install in the reverse order of removal.

WARNING:

- Ground cable must be connected.
- Spark may occur and ignite if fuel is nearby.

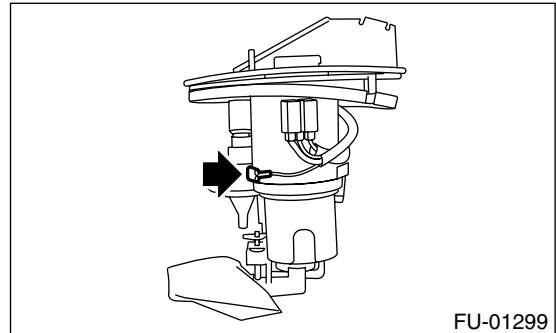

FUEL SUB LEVEL SENSOR

FUEL INJECTION (FUEL SYSTEMS)

28. Fuel Sub Level Sensor

A: REMOVAL

WARNING:

- Place “NO FIRE” signs near the working area.
- Be careful not to spill fuel on the floor.
- During work procedures, if fuel tank is more than 3/4 full, be careful because fuel may spill.

- 1) Drain fuel from fuel tank. <Ref. to FU(H4DOTC)-48, DRAINING FUEL, OPERATION, Fuel.>
- 2) Raise rear seat and turn floor mat up.
- 3) Remove service hole cover.

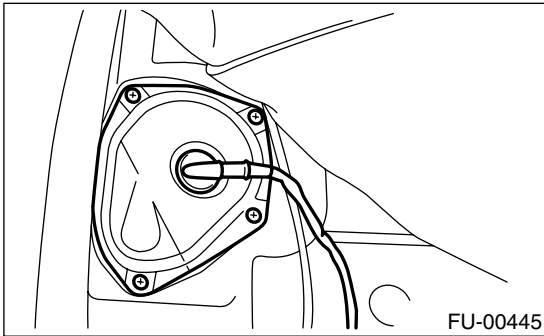

- 4) Disconnect connector from fuel sub level sensor.

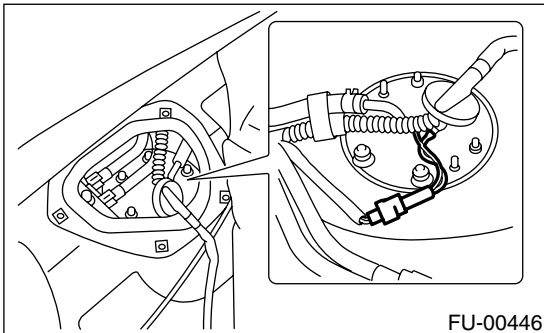

- 5) Disconnect fuel jet pump hose.

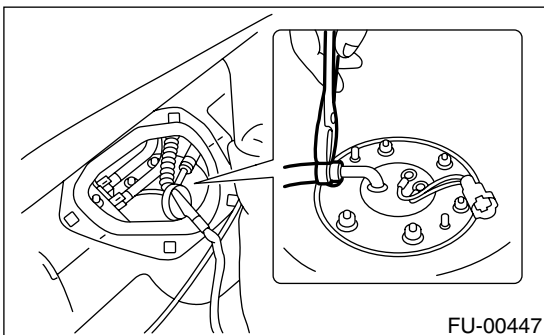

- 6) Remove bolts which install fuel sub level sensor on fuel tank.

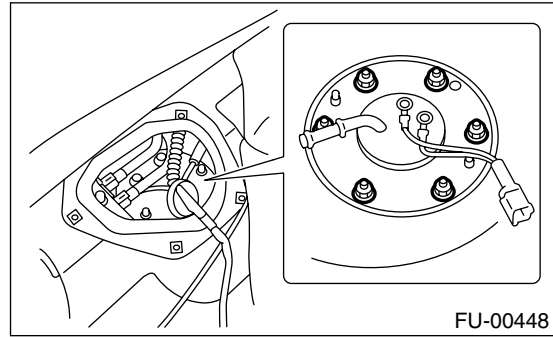

- 7) Remove fuel sub level sensor.

B: Installation

Install in the reverse order of removal.

Tightening torque:

4.4 N·m (0.45 kgf·m, 3.3 ft·lb)

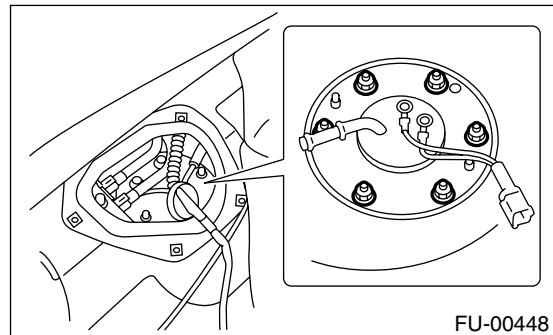

FUEL FILTER

FUEL INJECTION (FUEL SYSTEMS)

29. Fuel Filter

A: REMOVAL

WARNING:

- Place “NO FIRE” signs near the working area.
- Be careful not to spill fuel on the floor.

NOTE:

The fuel filter is built in fuel pump assembly.

- 1) Release the fuel pressure. <Ref. to FU(H4DOTC)-48, RELEASING OF FUEL PRESSURE, OPERATION, Fuel.>
- 2) Remove the fuel pump assembly. <Ref. to FU(H4DOTC)-67, REMOVAL, Fuel Pump.>
- 3) Disconnect the ground cable from filter holder.

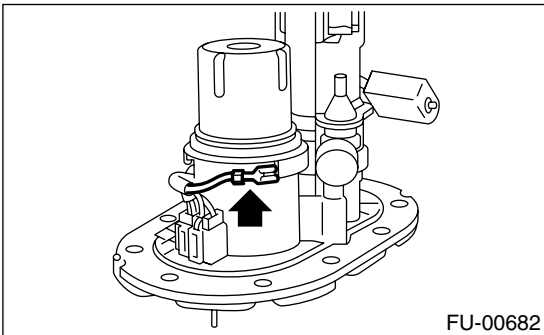

- 4) Remove the filter holder by turning it to the left from the body pawls, and then take out the filter.

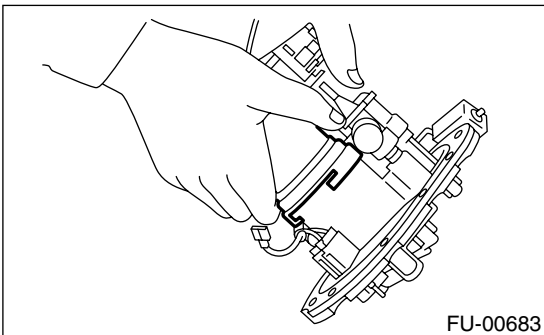

B: Installation

NOTE:

- If the fuel hoses are damaged at the connecting portion, replace it with a new one.
- If the clamps are badly damaged, replace with new ones.
- Replace the o-ring with new ones.

- 1) Set the O-ring on the filter holder, and then install by turning to the right.

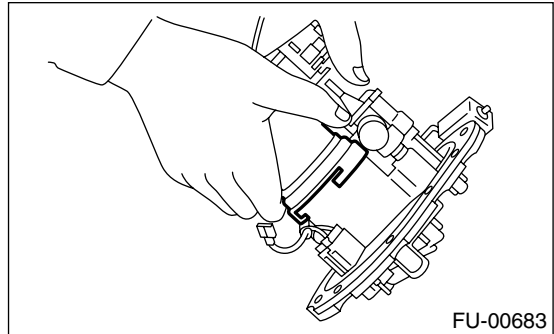

- 2) Connect the ground cable to filter holder.

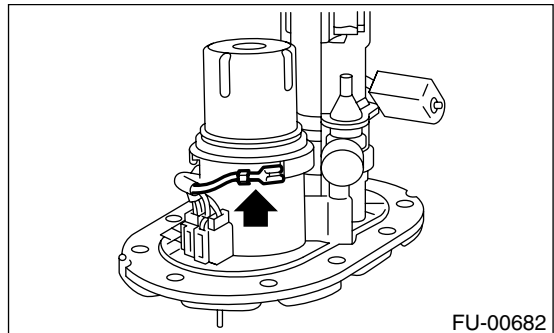

- 3) Install the fuel pump assembly. <Ref. to FU(H4DOTC)-68, INSTALLATION, Fuel Pump.>

C: INSPECTION

- 1) Check the inside of fuel filter for dirt and water sediment.
- 2) If it is clogged, or if replacement interval has been reached, replace it.

30. Fuel Cut Valve

A: REMOVAL

- 1) Remove fuel tank. <Ref. to FU(H4DOTC)-51, REMOVAL, Fuel Tank.>
- 2) Move clip and disconnect evaporation hose from fuel cut valve.

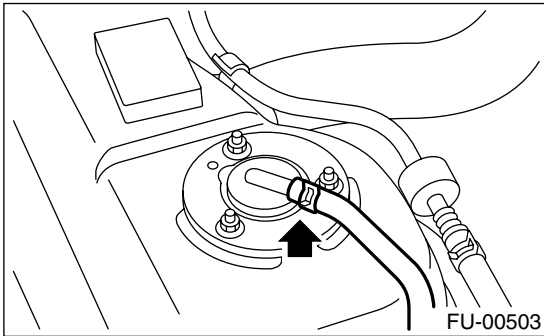

- 3) Remove bolts which install fuel cut valve.

B: INSTALLATION

Install in the reverse order of removal.

Tightening torque:

4.4 N·m (0.45 kgf·m, 3.3 ft-lb)

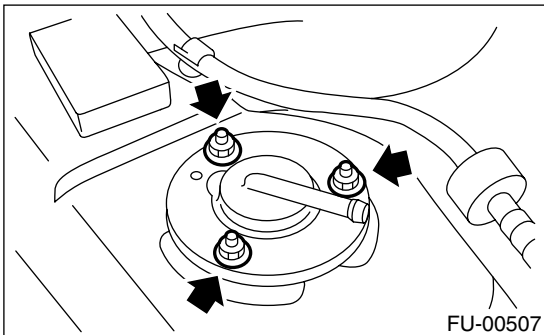

FUEL DAMPER VALVE

FUEL INJECTION (FUEL SYSTEMS)

31. Fuel Damper Valve

A: REMOVAL

- 1) Release the fuel pressure. <Ref. to FU(H4DOTC)-48, RELEASING OF FUEL PRESSURE, OPERATION, Fuel.>
- 2) Remove the fuel damper valve from the fuel delivery line and return line.

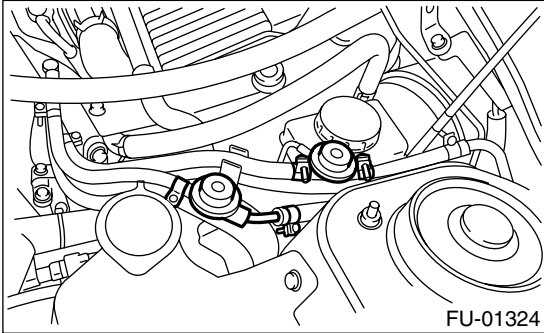

B: INSTALLATION

Install in the reverse order of removal.

Tightening torque:

1.25 N·m (0.13 kgf-m, 0.94 ft-lb)

FUEL DELIVERY, RETURN AND EVAPORATION LINES

FUEL INJECTION (FUEL SYSTEMS)

32. Fuel Delivery, Return and Evaporation Lines

A: REMOVAL

- 1) Set vehicle on the lift.
- 2) Release fuel pressure. <Ref. to FU(H4DOTC)-48, RELEASING OF FUEL PRESSURE, OPERATION, Fuel.>
- 3) Open fuel filler flap lid and remove fuel filler cap.

- 4) Remove fuel tank. <Ref. to FU(H4DOTC)-51, REMOVAL, Fuel Tank.>
- 5) Remove fuel filler pipe. <Ref. to FU(H4DOTC)-59, REMOVAL, Fuel Filler Pipe.>
- 6) Remove floor mat. <Ref. to EI-60, REMOVAL, Floor Mat.>
- 7) Remove fuel delivery pipes and hoses, fuel return pipes and hoses, evaporation pipes and hoses.

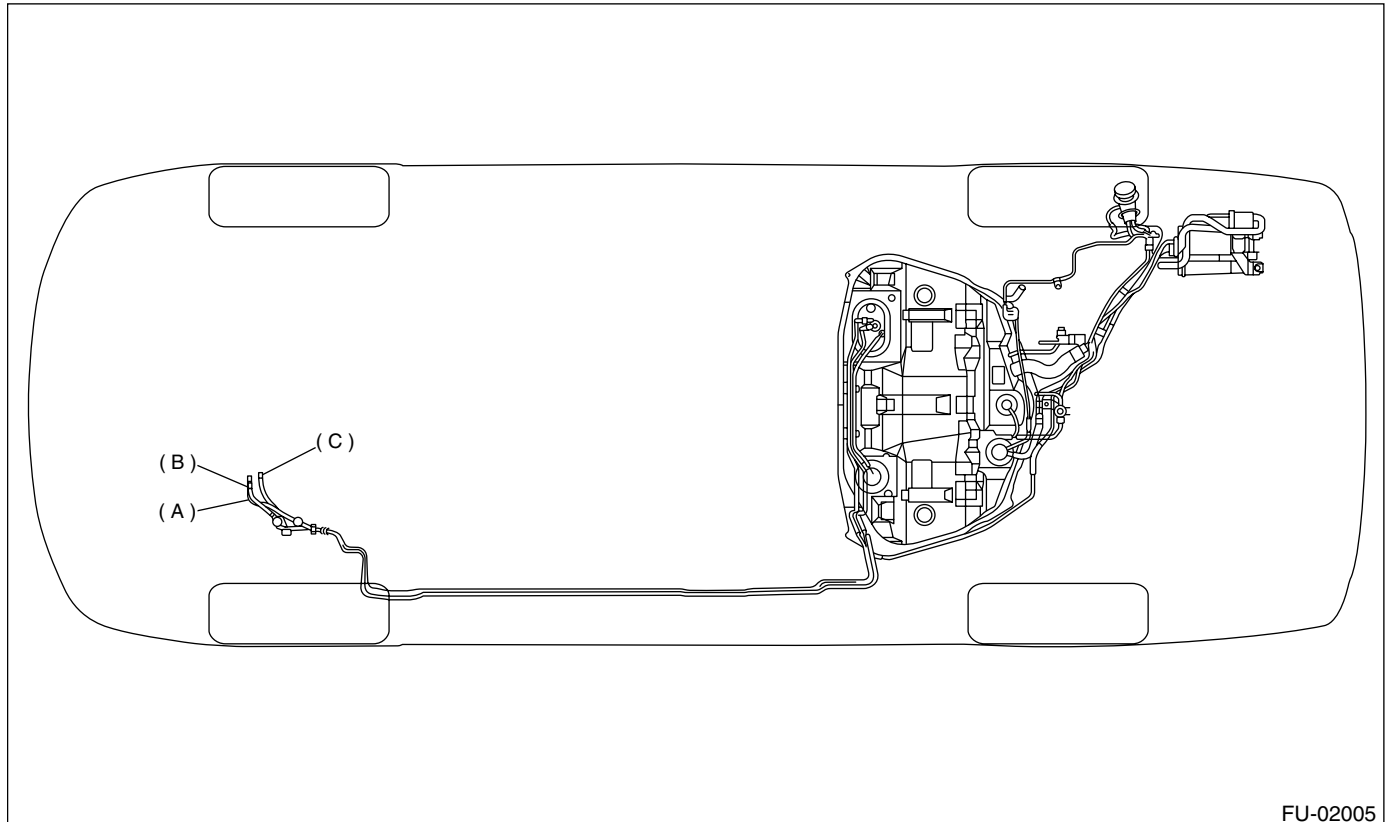

(A) Fuel delivery line

(B) Fuel return line

(C) Evaporation line

- 8) In engine room, detach fuel delivery hoses, return hoses and evaporation hose.

- (3) Pull out connector (A) from retainer (B).

CAUTION:
Replace retainer with new ones.

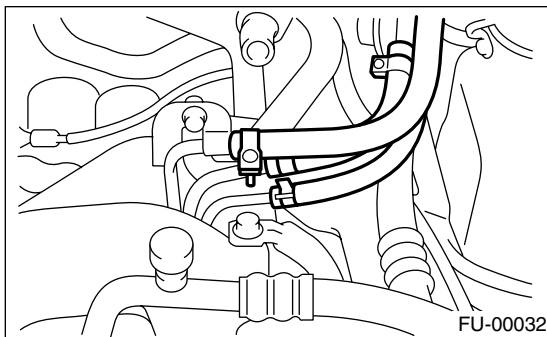

- 9) Separate quick connector on fuel delivery and return line.

- (1) Clean pipe and connector, if they are covered with dust.
- (2) Hold connector (A) and push retainer (B) down.

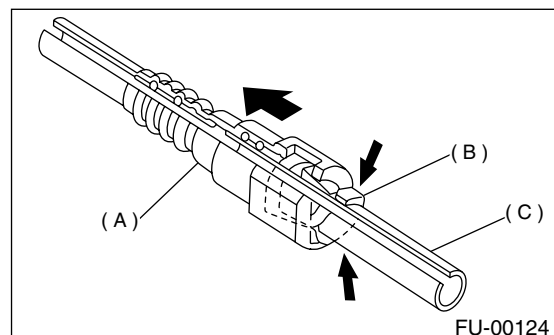

(A) Connector

(B) Retainer

(C) Pipe

FUEL DELIVERY, RETURN AND EVAPORATION LINES

FUEL INJECTION (FUEL SYSTEMS)

B: Installation

1) Connect quick connector on fuel delivery and return line.

CAUTION:

- Always use a new retainer.
- Make sure that the connected portion is not damaged or has dust. If necessary, clean seal surface (A) of pipe.

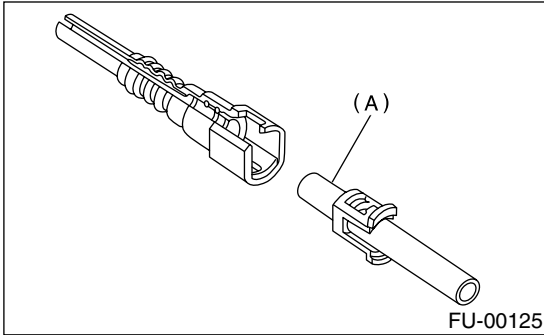

- (1) Set new retainer (B) to connector (A).
- (2) Push pipe into connector completely.

NOTE:

At this time, two clicking sounds are heard.

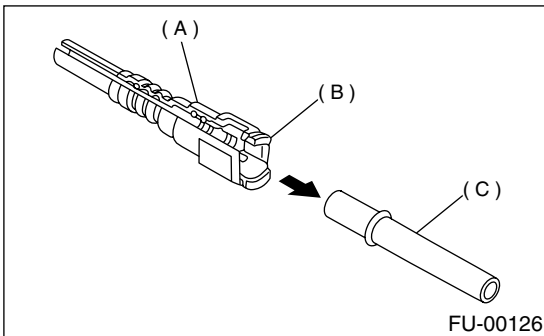

- (A) Connector
- (B) Retainer
- (C) Pipe

CAUTION:

- Pull the connector to ensure it is connected securely.
- Ensure the two retainer pawls are engaged in their mating positions in the connector.
- Be sure to inspect hoses and their connections for any leakage of fuel.

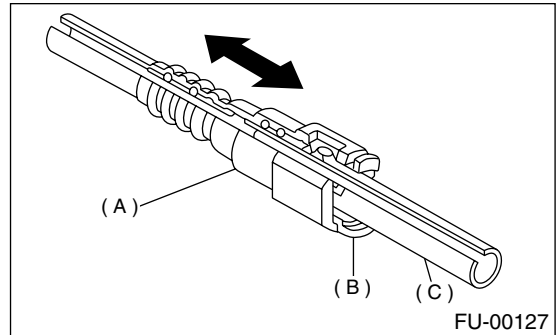

- (A) Connector
- (B) Retainer
- (C) Pipe

2) Connect fuel delivery hose to pipe with an overlap of 20 to 25 mm (0.79 to 0.98 in).

Type A: When insertion length is specified.

Type B: When insertion length is not specified.

$$\varnothing : 2.5 \pm 1.5 \text{ mm } (0.098 \pm 0.059 \text{ in})$$

$$L : 22.5 \pm 2.5 \text{ mm } (0.886 \pm 0.098 \text{ in})$$

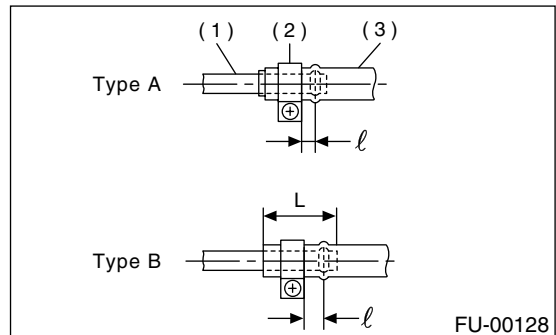

- (1) Pipe
- (2) Clamp
- (3) Hose

FUEL DELIVERY, RETURN AND EVAPORATION LINES

FUEL INJECTION (FUEL SYSTEMS)

3) Connect evaporation hose to pipe by approx. 15 mm (0.59 in) from hose end.

$L = 17.5 \pm 2.5 \text{ mm (0.689 \pm 0.098 in)}$

CAUTION:

Be sure to inspect hoses and their connections for any leakage of fuel.

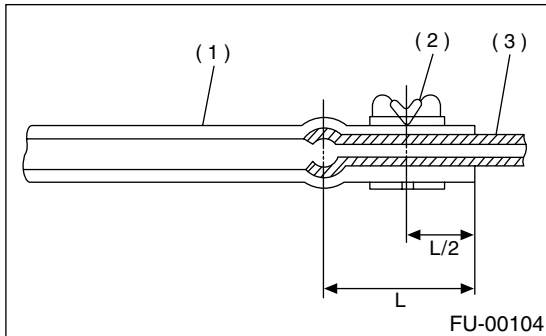

- (1) Hose
- (2) Clip
- (3) Pipe

C: INSPECTION

- 1) Make sure that there are no cracks on the fuel pipes and fuel hoses.
- 2) Make sure that the fuel pipe and fuel hose connections are tight.

FUEL SYSTEM TROUBLE IN GENERAL

FUEL INJECTION (FUEL SYSTEMS)

33. Fuel System Trouble in General

A: Inspection

Trouble and possible cause		Corrective action
1. Insufficient fuel supply to the injector		
1)	Fuel pump will not operate.	
	○ Defective terminal contact.	Inspect connections, especially ground, and tighten securely.
	○ Trouble in electromagnetic or electronic circuit parts.	Replace fuel pump.
2)	Lowering of fuel pump function.	Replace fuel pump.
3)	Clogged dust or water in the fuel filter.	Replace fuel filter, clean or replace fuel tank.
4)	Clogged or bent fuel pipe or hose.	Clean, correct or replace fuel pipe or hose.
5)	Air is mixed in the fuel system.	Inspect or retighten each connection part.
6)	Clogged or bent breather tube or pipe.	Clean, correct or replace air breather tube or pipe.
7)	Damaged diaphragm of pressure regulator.	Replace.
2. Leakage or blow out fuel		
1)	Loosened joints of the fuel pipe.	Retightening.
2)	Cracked fuel pipe, hose and fuel tank.	Replace.
3)	Defective welding part on the fuel tank.	Replace.
4)	Defective drain packing of the fuel tank.	Replace.
5)	Clogged or bent air breather tube or air vent tube.	Clean, correct or replace air breather tube or air vent tube.
3. Gasoline smell inside of compartment		
1)	Loose joints at air breather tube, air vent tube and fuel filler pipe.	Retightening.
2)	Defective packing air tightness on the fuel saucer.	Correct or replace packing.
3)	Cracked fuel separator.	Replace separator.
4)	Inoperative fuel pump modulator or circuit.	Replace.
4. Defective fuel level indicator		
1)	Defective operation of fuel level sensor.	Replace.
5. Noise		
1)	Large operation noise or vibration of fuel pump.	Replace.

NOTE:

- When the vehicle is left unattended for an extended period of time, water may accumulate in the fuel tank. To prevent water condensation.

- (1) Top off the fuel tank or drain the fuel completely.
- (2) Drain water condensation from the fuel filter.

- Refilling the fuel tank.

Refill the fuel tank while there is still some fuel left in the tank.

- Protecting the fuel system against freezing and water condensation.

- (1) Cold areas

In snow-covered areas, mountainous areas, skiing areas, etc. where ambient temperatures drop below 0°C (32°F) throughout the winter season, use an anti-freeze solution in the fuel tank. Refueling will also complement the effect of anti-freeze solution each time the fuel level drops to about one-half. After the winter season, drain water which may have accumulated in the fuel filter and fuel tank in the manner same as that described under damaged areas below.

- (2) Damaged areas

If water accumulated in the fuel filter, drain water from both the fuel filter and fuel tank or use an anti-freeze solution (water removing agent) in the fuel tank.

- Observe the instructions, notes, etc., indicated on the label affixed to the anti-freeze solution (water removing agent) container before use.