

EMISSION CONTROL (AUX. EMISSION CONTROL DEVICES)

EC(H4DOTC)

	Page
1. General Description	2
2. Front Catalytic Converter	3
3. Rear Catalytic Converter	4
4. Canister	5
5. Purge Control Solenoid Valve	6
6. Main Fuel Level Sensor	7
7. Fuel Temperature Sensor	8
8. Sub Fuel Level Sensor	9
9. Fuel Tank Pressure Sensor	10
10. Fuel Tank Sensor Control Valve	11
11. Pressure Control Solenoid Valve	12
12. Drain Filter.....	13
13. Vent Valve.....	14
14. Shut Valve.....	15
15. Drain Valve.....	16
16. PCV Hose Assembly	17

GENERAL DESCRIPTION

EMISSION CONTROL (AUX. EMISSION CONTROL DEVICES)

1. General Description

A: CAUTION

- Wear working clothing, including a cap, protective goggles, and protective shoes during operation.
- Remove contamination including dirt and corrosion before removal, installation or disassembly.
- Keep the disassembled parts in order and protect them from dust or dirt.
- Before removal, installation or disassembly, be sure to clarify the failure. Avoid unnecessary removal, installation, disassembly, and replacement.
- Be careful not to burn your hands, because each part on the vehicle is hot after running.
- Be sure to tighten fasteners including bolts and nuts to the specified torque.
- Place shop jacks or safety stands at the specified points.
- Before disconnecting electrical connectors of sensors or units, be sure to disconnect the negative terminal from battery.

B: PREPARATION TOOL

1. SPECIAL TOOLS

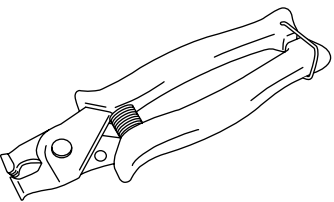
ILLUSTRATION	TOOL NUMBER	DESCRIPTION	REMARKS
 ST18353AA000	18353AA000	CLAMP PLIERS	<ul style="list-style-type: none">• Used for removing and installing PCV hose.• This tool is a general tool that is made by CAILLAU in France. (Code: 54.0.000.205) Tool number is fixed as special tool in order to obtain it as easily as SUBARU genuine parts.

FRONT CATALYTIC CONVERTER

EMISSION CONTROL (AUX. EMISSION CONTROL DEVICES)

2. Front Catalytic Converter

A: REMOVAL

1) Remove the center exhaust pipe. <Ref. to EX(H4DOTC)-9, REMOVAL, Center Exhaust Pipe.>

2) Separate the front catalytic converter (A) from rear catalytic converter (B).

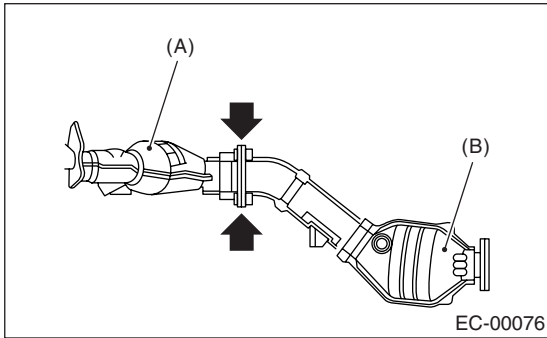

B: INSTALLATION

NOTE:

- Replace the gaskets with new ones.
- Install in the reverse order of removal.

C: INSPECTION

- 1) Make sure there are no exhaust leaks from connections and welds.
- 2) Make sure there are no holes or rusting.

REAR CATALYTIC CONVERTER

EMISSION CONTROL (AUX. EMISSION CONTROL DEVICES)

3. Rear Catalytic Converter

A: REMOVAL

- 1) Remove the center exhaust pipe. <Ref. to EX(H4DOTC)-9, REMOVAL, Center Exhaust Pipe.>
- 2) Separate the rear catalytic converter (B) from front catalytic converter (A).

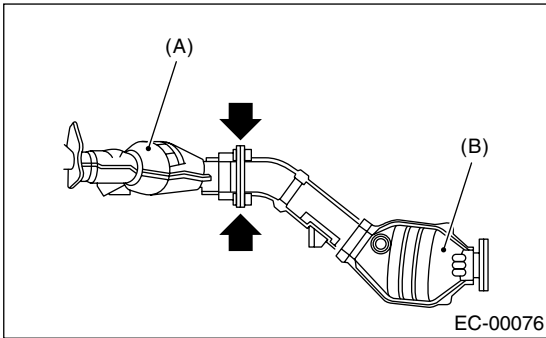

B: INSTALLATION

NOTE:

- Replace the gaskets with new ones.
- Install in the reverse order of removal.

C: INSPECTION

- 1) Make sure there are no exhaust leaks from connections and welds.
- 2) Make sure there are no holes or rusting.

CANISTER

EMISSION CONTROL (AUX. EMISSION CONTROL DEVICES)

4. Canister

A: REMOVAL

- 1) Lift-up the vehicle.
- 2) Loosen two clamps which hold two canister hoses, and disconnect evaporation three hoses from canister.

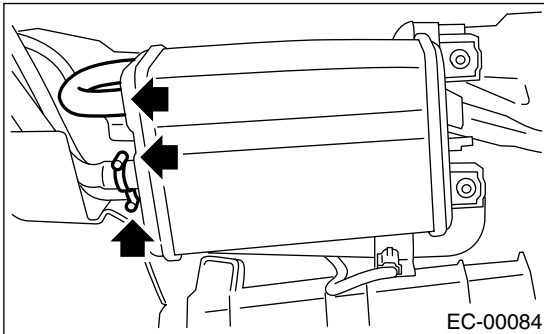

- 3) Remove canister from body.

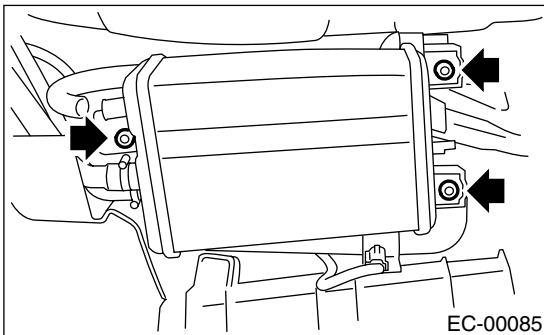

B: INSTALLATION

- 1) Install in the reverse order of removal.

Tightening torque:

23 N·m (2.3 kgf-m, 17 ft-lb)

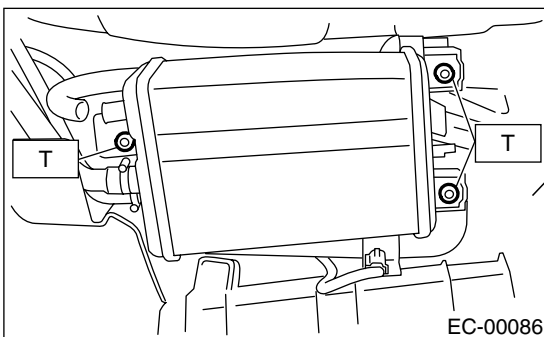

C: INSPECTION

Make sure the canister and canister hoses are not cracked or loose.

PURGE CONTROL SOLENOID VALVE

EMISSION CONTROL (AUX. EMISSION CONTROL DEVICES)

5. Purge Control Solenoid Valve

A: REMOVAL

- 1) Disconnect ground cable from battery.

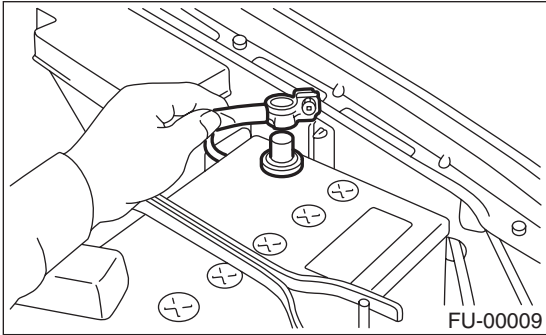

- 2) Disconnect the connector and hoses from purge control solenoid valve.
- 3) Remove the bolt which installs the purge control solenoid valve onto intake manifold.

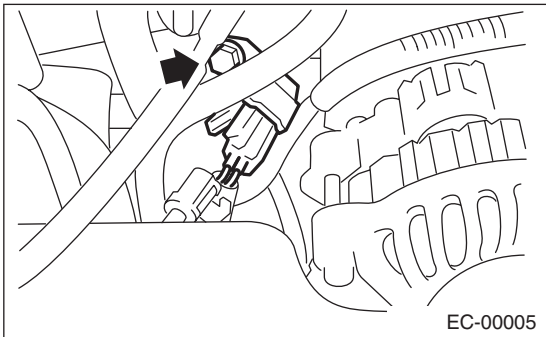

B: INSTALLATION

Install in the reverse order of removal.

Tightening torque:

16 N·m (1.6 kgf-m, 11.6 ft-lb)

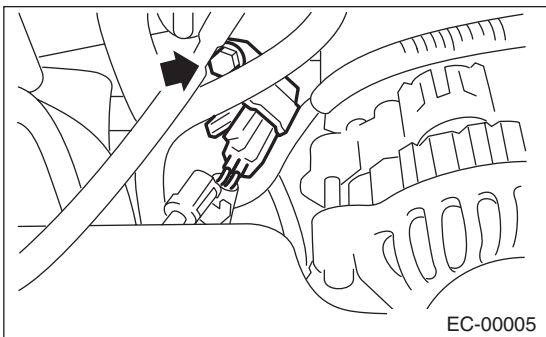

NOTE:

Connect the evaporation hoses as shown in the figure.

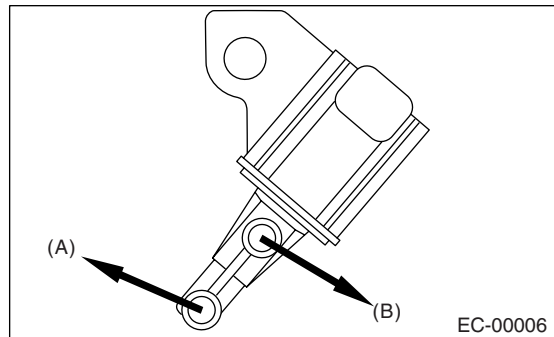

(A) To purge valve

(B) To intake manifold

C: INSPECTION

Make sure the hoses are not cracked or loose.

MAIN FUEL LEVEL SENSOR

EMISSION CONTROL (AUX. EMISSION CONTROL DEVICES)

6. Main Fuel Level Sensor

A: REMOVAL

For work procedures, refer to FU(H4DOTC) section. <Ref. to FU(H4DOTC)-70, REMOVAL, Fuel Level Sensor.>

B: INSTALLATION

For work procedures, refer to FU(H4DOTC) section. <Ref. to FU(H4DOTC)-70, INSTALLATION, Fuel Level Sensor.>

FUEL TEMPERATURE SENSOR

EMISSION CONTROL (AUX. EMISSION CONTROL DEVICES)

7. Fuel Temperature Sensor

A: REMOVAL

WARNING:

During work procedures, if fuel tank is more than 3/4 full, be careful because fuel may spill.

NOTE:

Fuel temperature sensor is built in fuel pump assembly.

- 1) Remove fuel pump assembly. <Ref. to FU(H4DOTC)-67, REMOVAL, Fuel Pump.>
- 2) Disconnect connector from fuel pump bracket.

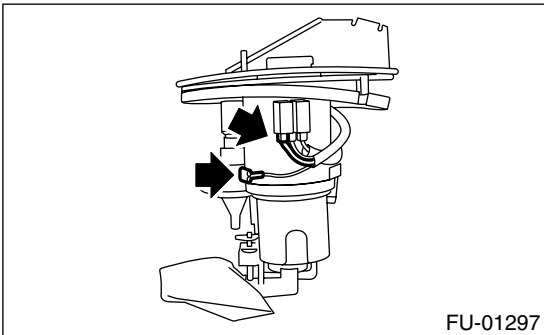

- 3) Remove fuel temperature sensor.

NOTE:

When replacing fuel temperature sensor, also replace fuel level sensor. <Ref. to FU(H4DOTC)-70, REMOVAL, Fuel Level Sensor.>

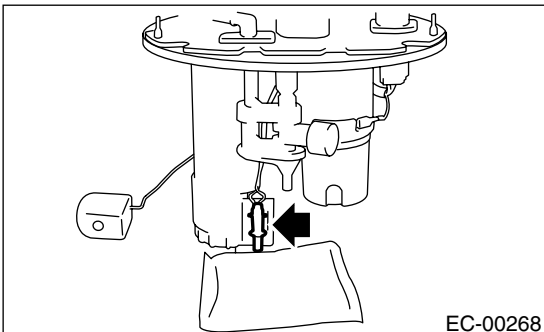

B: Installation

- 1) Install in the reverse order of removal.

WARNING:

- Ground cable must be connected.
- Spark may occur and ignite if fuel is nearby.

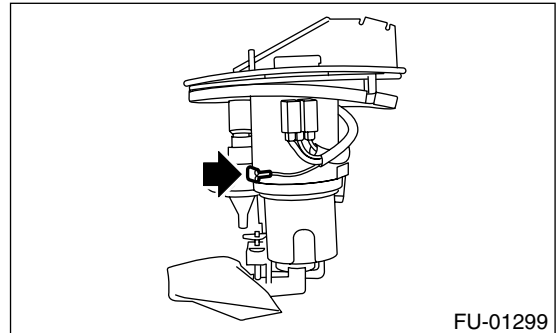

SUB FUEL LEVEL SENSOR

EMISSION CONTROL (AUX. EMISSION CONTROL DEVICES)

8. Sub Fuel Level Sensor

A: REMOVAL

For work procedures, refer to “FU(H4DOTC)” section. <Ref. to FU(H4DOTC)-71, REMOVAL, Fuel Sub Level Sensor.>

B: INSTALLATION

For work procedures, refer to “FU(H4DOTC)” section. <Ref. to FU(H4DOTC)-71, INSTALLATION, Fuel Sub Level Sensor.>

FUEL TANK PRESSURE SENSOR

EMISSION CONTROL (AUX. EMISSION CONTROL DEVICES)

9. Fuel Tank Pressure Sensor

A: REMOVAL

- 1) Set the vehicle on the lift.
- 2) Open fuel flap lid, and remove fuel filler cap.
- 3) Disconnect ground cable from battery.

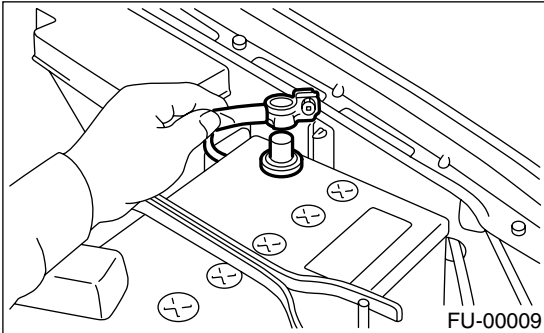

- 4) Lift-up the vehicle.
- 5) Disconnect connector from fuel tank pressure sensor and fuel tank sensor control valve.
- 6) Disconnect pressure hose from fuel tank pressure sensor.

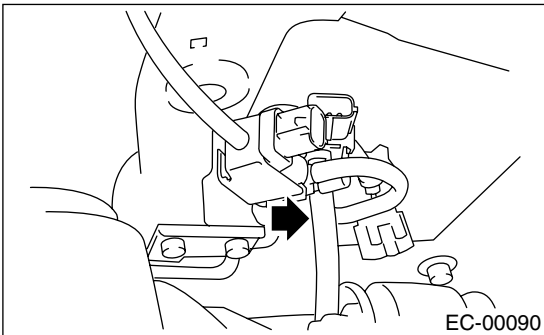

- 7) Remove fuel tank pressure sensor and fuel tank sensor control valve with bracket.

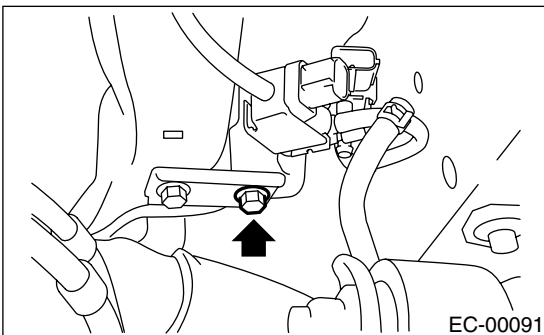

- 8) Remove fuel tank sensor control valve from bracket.

NOTE:

Fuel tank pressure sensor cannot be removed because it is integral with bracket.

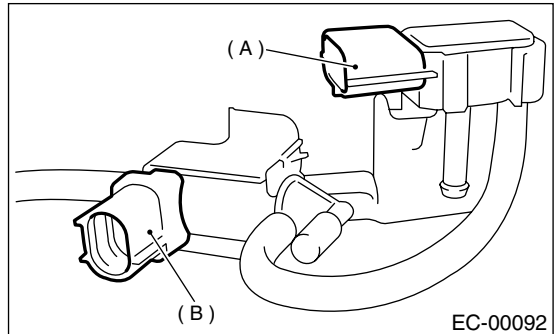

- (A) Fuel tank pressure sensor
(B) Fuel tank sensor control valve

B: INSTALLATION

Install in the reverse order of removal.

Tightening torque:

7.4 N·m (0.75 kgf-m, 5.4 ft-lb)

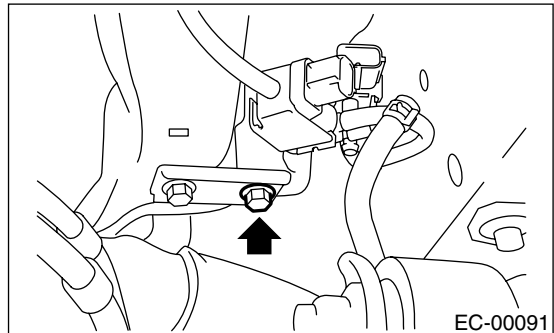

C: INSPECTION

Make sure that hoses are not cracked or loose.

FUEL TANK SENSOR CONTROL VALVE

EMISSION CONTROL (AUX. EMISSION CONTROL DEVICES)

10. Fuel Tank Sensor Control Valve

A: REMOVAL

1) Remove fuel tank pressure sensor. <Ref. to EC(H4DOTC)-10, REMOVAL, Fuel Tank Pressure Sensor.>

2) Remove fuel tank sensor control valve from bracket.

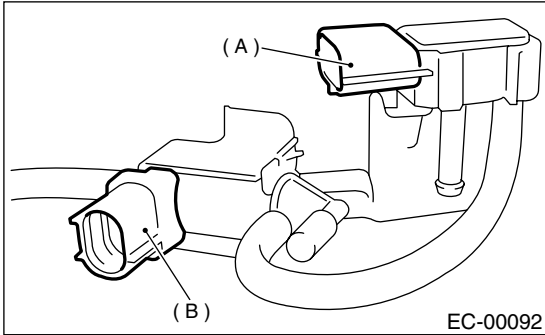

- (1) Fuel tank pressure sensor
- (2) Fuel tank sensor control valve

B: INSTALLATION

Install in the reverse order of removal.

C: INSPECTION

Make sure that hoses are not cracked or loose.

PRESSURE CONTROL SOLENOID VALVE

EMISSION CONTROL (AUX. EMISSION CONTROL DEVICES)

11. Pressure Control Solenoid Valve

A: REMOVAL

- 1) Set the vehicle on the lift.
- 2) Disconnect ground cable from battery.

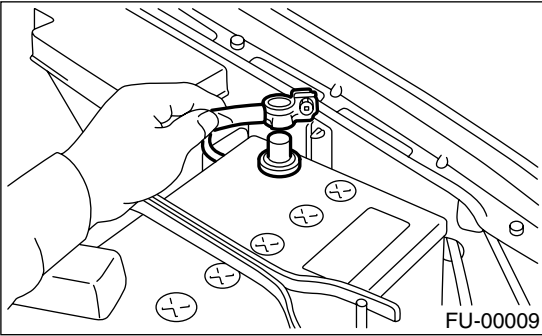

- 3) Lift-up the vehicle.
- 4) Disconnect connector from pressure control solenoid valve.

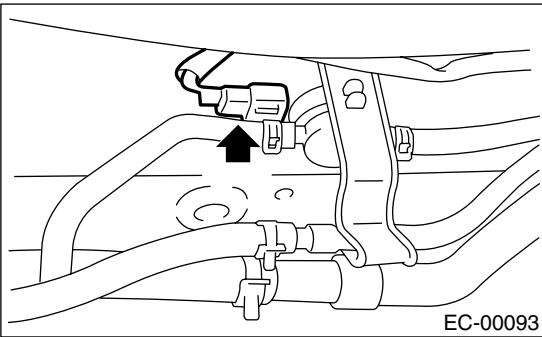

- 5) Disconnect two evaporation hoses from pressure control solenoid valve.

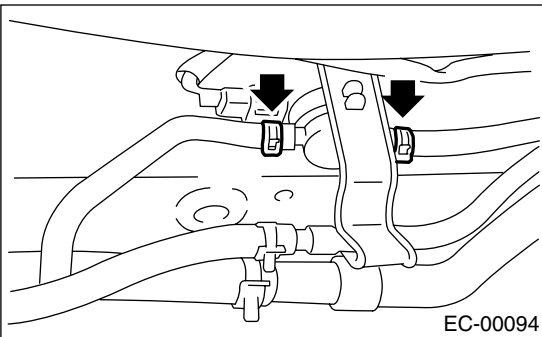

- 6) Remove pressure control solenoid valve from bracket.

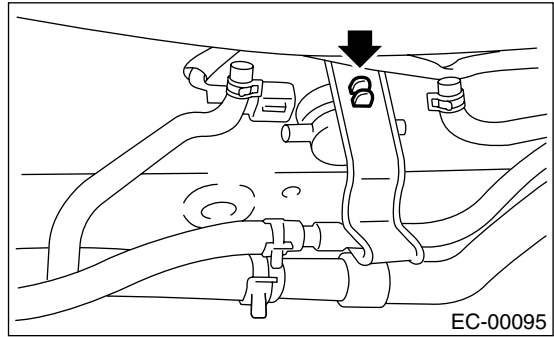

B: INSTALLTION

Install in the reverse order of removal.

C: INSPECTION

Make sure that hoses are not cracked or loose.

DRAIN FILTER

EMISSION CONTROL (AUX. EMISSION CONTROL DEVICES)

12. Drain Filter

A: REMOVAL

- 1) Set the vehicle on the lift.
- 2) Disconnect battery ground cable.

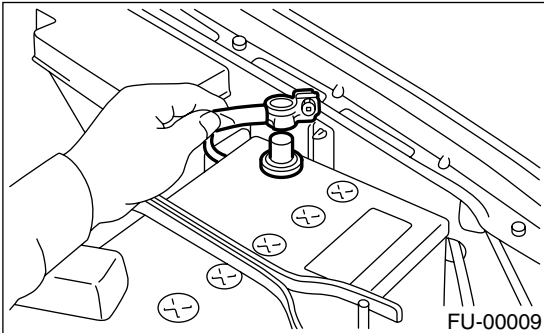

- 3) Lift-up the vehicle.
- 4) Remove canister. <Ref. to EC(H4DOTC)-5, REMOVAL, Canister.>
- 5) Disconnect connector from drain valve.

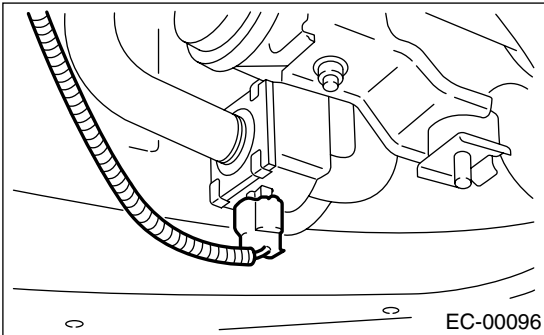

- 6) Remove nut which installs drain filter and drain valve brackets on body, and remove them as a unit.

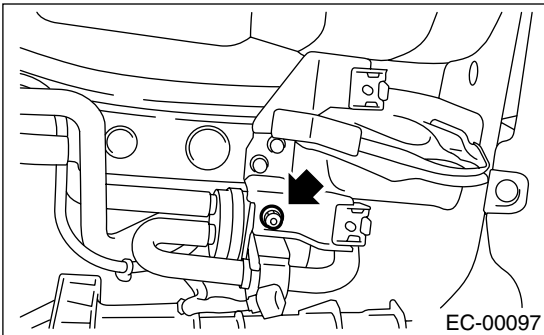

- 7) Disconnect evaporation hoses, (a) and remove drain filter (b).

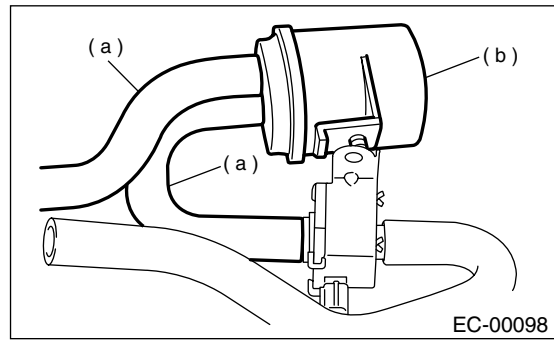

B: INSTALLATION

Install in the reverse order of removal.

Tightening torque:

18 N·m (1.8 kgf-m, 13.0 ft-lb)

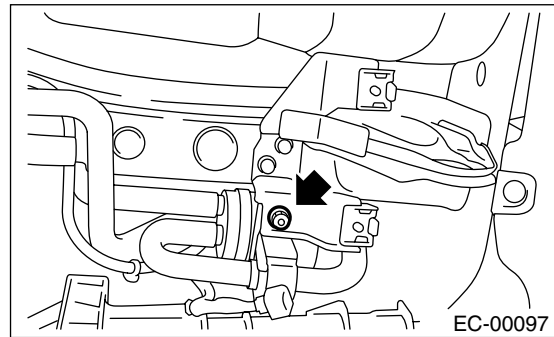

C: INSPECTION

- 1) Make sure that all hoses are installed correctly.
- 2) Make sure that hoses are not cracked or loose.

VENT VALVE

EMISSION CONTROL (AUX. EMISSION CONTROL DEVICES)

13.Vent Valve

A: REMOVAL

- 1) Remove fuel tank. <Ref. to FU(H4DOTC)-51, REMOVAL, Fuel Tank.>
- 2) Move clips, and disconnect hoses from vent valve.

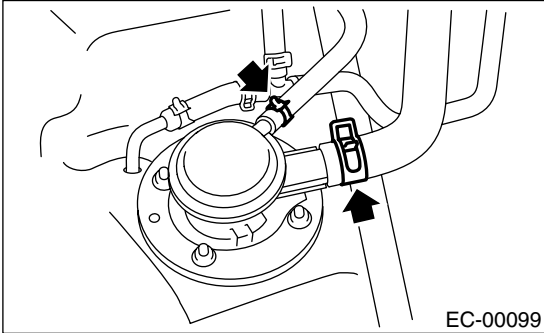

- 3) Remove nuts which install vent valve on fuel tank.

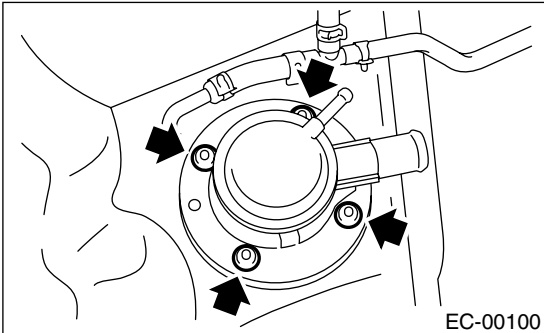

B: INSTALLATION

Install in the reverse order of removal.

NOTE:

Replace rubber seat with a new one.

Tightening torque:

4.4 N·m (0.45 kgf-m, 3.3 ft-lb)

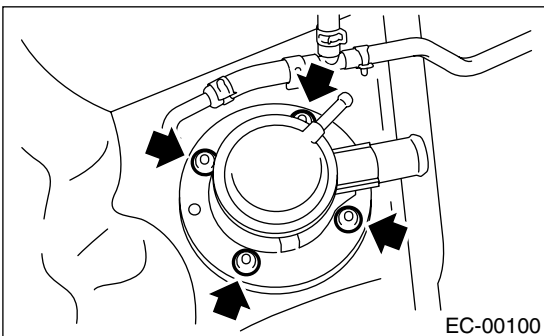

C: INSPECTION

Make sure that hoses are not cracked or loose.

SHUT VALVE

EMISSION CONTROL (AUX. EMISSION CONTROL DEVICES)

14. Shut Valve

A: REMOVAL

- 1) Drain fuel from fuel tank. <Ref. to FU(H4DOTC)-48, DRAINING FUEL, OPERATION, Fuel.>
- 2) Remove fuel filler pipe. <Ref. to FU(H4DOTC)-59, REMOVAL, Fuel Filler Pipe.>
- 3) Disconnect evaporation hoses from shut valve.

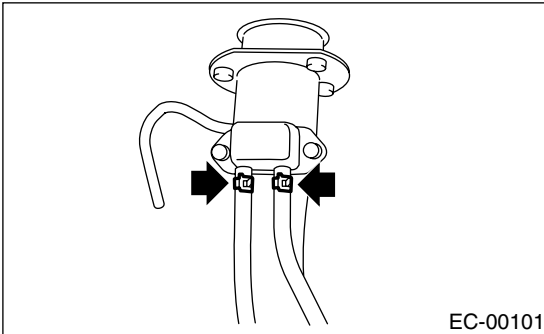

- 4) Remove shut valve from fuel filler pipe.

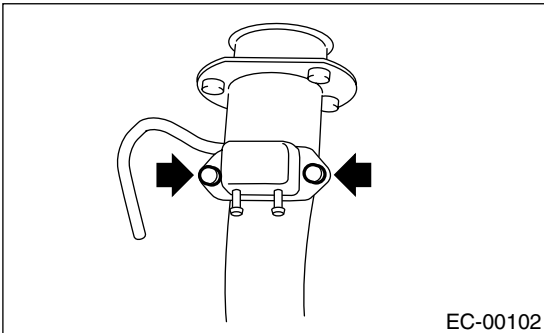

B: INSTALLATION

Install in the reverse order of removal.

Tightening torque:

4.4 N·m (0.45 kgf·m, 3.3 ft·lb)

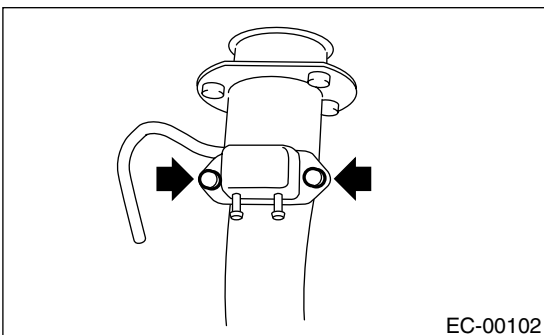

C: INSPECTION

Make sure that hoses are not cracked or loose.

DRAIN VALVE

EMISSION CONTROL (AUX. EMISSION CONTROL DEVICES)

15. Drain Valve

A: REMOVAL

- 1) Set the vehicle on the lift.
- 2) Disconnect battery ground cable.

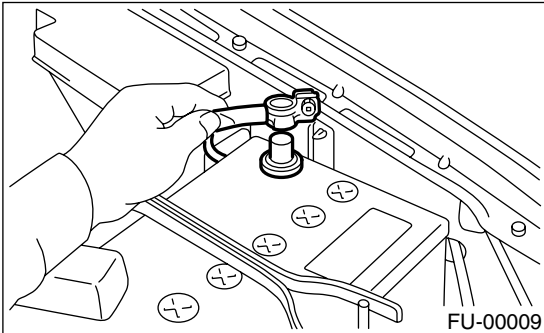

- 3) Lift-up the vehicle.
- 4) Remove canister. <Ref. to EC(H4DOTC)-5, REMOVAL, Canister.>
- 5) Disconnect connector from drain valve.

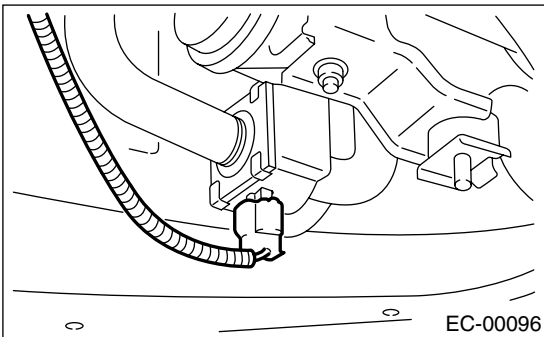

- 6) Remove bolt which installs drain filter and drain valve brackets on body.

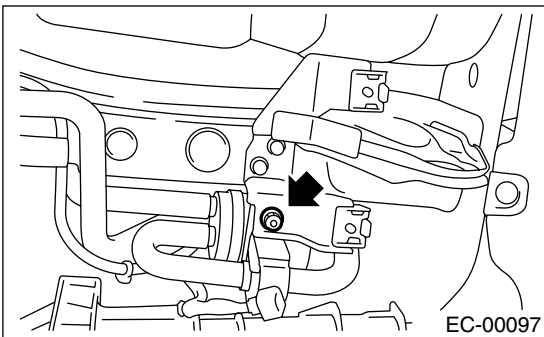

- 7) Disconnect evaporation hose and remove drain valve.

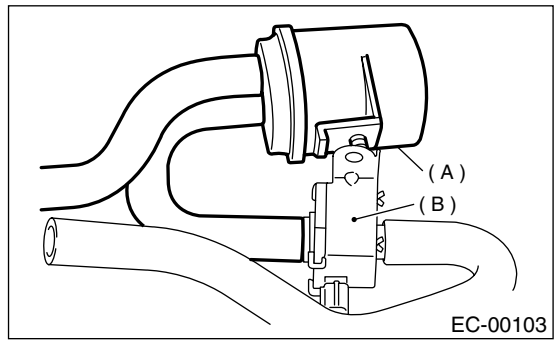

- (1) Drain filter
- (2) Drain valve

B: INSTALLATION

Install in the reverse order of removal.

Tightening torque:

18 N·m (1.8 kgf-m, 13.0 ft-lb)

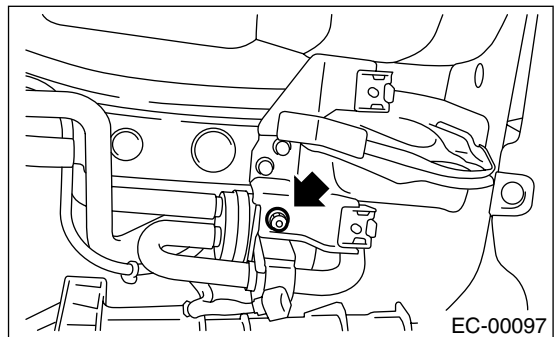

C: INSPECTION

- 1) Make sure that all hoses are installed correctly.
- 2) Make sure that hoses are not cracked or loose.

PCV HOSE ASSEMBLY

EMISSION CONTROL (AUX. EMISSION CONTROL DEVICES)

16.PCV Hose Assembly

A: REMOVAL

CAUTION:

Removal is not allowed except for the damage of PCV hose, diagnosis connector and PCV valve.

- 1) Remove the intake manifold.
<Ref. to FU(H4DOTC)-15, REMOVAL, Intake Manifold.>
- 2) Unlock with a dent of special tool clipped by a protrusion of clamp.
- 3) Remove the PCV hose assembly.
ST 18353AA000 CLUMP PLIER

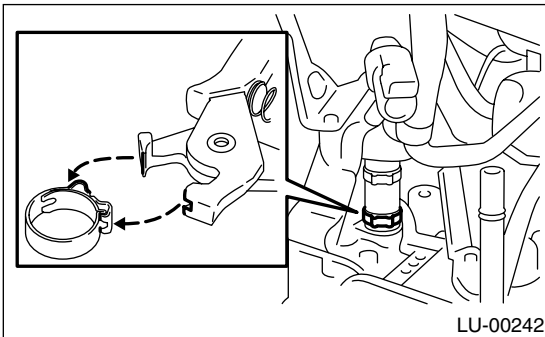

B: INSTALLATION

NOTE:

Replace the clamp with a new one.

- 1) Install the PCV hose assembly and lock it with a protrusion of clamp clipped by special tool.
ST 18353AA000 CLUMP PLIER

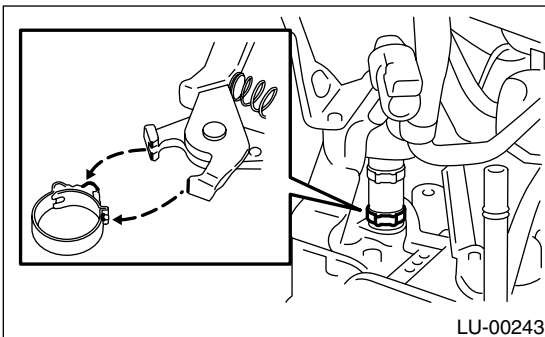

- 2) Install the intake manifold.
<Ref. to FU(H4DOTC)-17, INSTALLATION, Intake Manifold.>

PCV HOSE ASSEMBLY

EMISSION CONTROL (AUX. EMISSION CONTROL DEVICES)

MEMO: