

MECHANICAL

ME(H4DOTC)

	Page
1. General Description	2
2. Compression	24
3. Idle Speed	25
4. Ignition Timing	26
5. Intake Manifold Vacuum.....	27
6. Engine Oil Pressure	28
7. Fuel Pressure	29
8. Valve Clearance	30
9. Engine Assembly	34
10. Engine Mounting	43
11. Preparation for Overhaul.....	44
12. V-belt.....	45
13. Crankshaft Pulley	47
14. Timing Belt Cover.....	48
15. Timing Belt Assembly.....	49
16. Camshaft Sprocket.....	57
17. Crankshaft Sprocket.....	58
18. Camshaft.....	59
19. Cylinder Head Assembly	65
20. Cylinder Block	72
21. Intake and Exhaust Valve	93
22. Piston	94
23. Connecting Rod	95
24. Crankshaft.....	96
25. Engine Trouble in General	97
26. Engine Noise	102

GENERAL DESCRIPTION

MECHANICAL

1. General Description

A: SPECIFICATIONS

Engine	Type		Horizontally opposed, liquid cooled, 4-cylinder, 4-stroke gasoline engine		
	Valve arrangement		Belt driven, double overhead camshaft, 4-valve/cylinder		
	Bore × Stroke		mm (in)	99.5 × 79.0 (3.917 × 3.110)	
	Piston displacement		cm ³ (cu in)	2,457 (150)	
	Compression ratio		8.2		
	Compression pressure (at 200 — 300 rpm)		kPa (kgf/cm ² , psi)	981 — 1,177 (10 — 12, 142 — 171)	
	Number of piston rings		Pressure ring: 2, Oil ring: 1		
	Intake valve timing	Opening	Max. retard	ATDC 5°	
			Min. advance	BTDC 15°	
		Closing	Max. retard	ABDC 65°	
			Min. advance	ABDC 45°	
	Exhaust valve timing	Opening		BBDC 55°	
		Closing		ATDC 5°	
	Valve clearance	Intake	mm (in)	0.20 ^{+0.04} _{-0.06} (0.0079 ^{+0.0016} _{-0.0024})	
		Exhaust	mm (in)	0.35±0.05 (0.0138±0.0020)	
	Idling speed [At neutral position on MT, "P" or "N" position on AT]		No load	M/T: 700±100	
				A/T: 700±100	
			A/C ON	A/C refrigerant pressure low	M/T: 725±100
A/C refrigerant pressure high	A/T: 750±100				
Firing order		1 → 3 → 2 → 4			
Ignition timing		BTDC/rpm	MT:13°±10°		
			AT:17°±10°		

NOTE:

STD: Standard I.D.: Inner Diameter O.D.: Outer Diameter OS: Oversize US: Undersize

GENERAL DESCRIPTION

MECHANICAL

Belt tension adjuster	Protrusion of adjuster rod			5.2 — 6.2 mm (0.205 — 0.244 in)
Belt tensioner	Spacer O.D.			17.955 — 17.975 mm (0.7069 — 0.7077 in)
	Tensioner bush I.D.			18.0 — 18.08 mm (0.7087 — 0.7118 in)
	Clearance between spacer and bush	STD		0.025 — 0.125 mm (0.0010 — 0.0049 in)
		Limit		0.175 mm (0.0069 in)
	Side clearance of spacer	STD		0.2 — 0.55 mm (0.0079 — 0.0217 in)
Limit			0.81 mm (0.0319 in)	
Camshaft	Bend limit			0.020 mm (0.00079 in)
	Thrust clearance		STD	0.068 — 0.116 mm (0.0027 — 0.0046 in)
			Limit	0.14 mm (0.0055 in)
	Cam lobe height	Intake	STD	46.55 — 46.65 mm (1.833 — 1.837 in)
			Limit	46.45 mm (1.829 in)
		Exhaust	STD	46.75 — 46.85 mm (1.841 — 1.844 in)
			Limit	46.65 mm (1.837 in)
	Journal O.D.	STD	Front	37.946 — 37.963 mm (1.4939 — 1.4946 in)
			Center	29.946 — 29.963 mm (1.1790 — 1.1796 in)
			rear	
Oil clearance		STD	0.037 — 0.072 mm (0.0015 — 0.0028 in)	
		Limit	0.10 mm (0.0039 in)	
Cylinder head	Surface warpage limit			0.05 mm (0.0020 in)
	Surface grinding limit			0.3 mm (0.012 in)
	Standard height			127.5 mm (5.02 in)
Valve seat	Refacing angle			90°
	Contacting width	Intake	STD	1.0 mm (0.039 in)
			Limit	1.7 mm (0.067 in)
		Exhaust	STD	1.5 mm (0.059 in)
			Limit	2.2 mm (0.087 in)
Valve guide	Inner diameter			6.000 — 6.012 mm (0.2362 — 0.2367 in)
	Protrusion above head			15.8 — 16.2 mm (0.622 — 0.638 in)
Valve	Head edge thickness	Intake	STD	1.2 mm (0.047 in)
			Limit	0.8 mm (0.031 in)
		Exhaust	STD	1.5 mm (0.059 in)
			Limit	0.8 mm (0.031 in)
	Stem diameter		Intake	5.955 — 5.970 mm (0.2344 — 0.2350 in)
			Exhaust	5.945 — 5.960 mm (0.2341 — 0.2346 in)
	Stem oil clearance	STD	Intake	0.030 — 0.057 mm (0.0012 — 0.0022 in)
			Exhaust	0.040 — 0.067 mm (0.0016 — 0.0026 in)
Limit		—	0.15 mm (0.0059 in)	
Overall length		Intake	104.4 mm (4.110 in)	
		Exhaust	104.65 mm (4.120 in)	
Valve spring	Free length			47.32 mm (1.863 in)
	Squareness			2.5°, 2.1 mm (0.083 in)
	Tension/spring height		Set	205 — 235 N (20.9 — 24.0 kgf, 46.1 — 52.8 lb)/ 36.0 mm (1.417 in)
			Lift	426 — 490 N (43.4 — 50.0 kgf, 95.8 — 110 lb)/ 26.50 mm (1.043 in)

GENERAL DESCRIPTION

MECHANICAL

Cylinder block	Surface warpage limit (mating with cylinder head)			0.05 mm (0.0020 in)
	Surface grinding limit			0.1 mm (0.004 in)
	Standard height			201.0 mm (7.91 in)
	Cylinder bore	STD	A	99.505 — 99.515 mm (3.9175 — 3.9179 in)
			B	99.495 — 99.505 mm (3.9171 — 3.9175 in)
	Taper	STD		0.015 mm (0.0006 in)
		Limit		0.050 mm (0.0020 in)
	Out-of-roundness	STD		0.010 mm (0.0004 in)
		Limit		0.050 mm (0.0020 in)
	Piston clearance	STD		-0.010 — 0.010 mm (-0.0004 — 0.0004 in)
Limit		0.030 mm (0.0012 in)		
Enlarging (boring) limit			0.5 mm (0.020 in)	
Piston	Outer diameter	STD	A	99.505 — 99.515 mm (3.9175 — 3.9179 in)
			B	99.495 — 99.505 mm (3.9171 — 3.9175 in)
		0.25 mm (0.0098 in) OS		99.745 — 99.765 mm (3.9270 — 3.9278 in)
		0.50 mm (0.0197 in) OS		99.995 — 100.015 mm (3.9368 — 3.9376 in)
Piston pin	Standard clearance between piston pin and hole in piston		STD	0.004 — 0.008 mm (0.0002 — 0.0003 in)
			Limit	0.020 mm (0.0008 in)
	Degree of fit			Piston pin must be fitted into position with thumb at 20°C (68°F).
Piston ring	Piston ring gap	Top ring	STD	0.20 — 0.25 mm (0.0079 — 0.0098 in)
			Limit	1.0 mm (0.039 in)
		Second ring	STD	0.37 — 0.52 mm (0.015 — 0.020 in)
			Limit	1.0 mm (0.039 in)
	Oil ring	STD	0.20 — 0.50 mm (0.0079 — 0.020 in)	
		Limit	1.5 mm (0.059 in)	
	Clearance between piston ring and piston ring groove	Top ring	STD	0.040 — 0.080 mm (0.0016 — 0.0031 in)
			Limit	0.15 mm (0.0059 in)
Second ring		STD	0.030 — 0.070 mm (0.0012 — 0.0028 in)	
		Limit	0.15 mm (0.0059 in)	
Connecting rod	Bend twist per 100 mm (3.94 in) in length		Limit	0.10 mm (0.0039 in)
	Side clearance	STD		0.070 — 0.330 mm (0.0028 — 0.0130 in)
		Limit		0.4 mm (0.016 in)
Connecting rod bearing	Oil clearance	STD		0.017 — 0.045 mm (0.0007 — 0.0018 in)
		Limit		0.05 mm (0.0020 in)
	Thickness at center portion	STD		1.490 — 1.502 mm (0.0587 — 0.0591 in)
		0.03 mm (0.0012 in) US		1.504 — 1.512 mm (0.0592 — 0.0595 in)
		0.05 mm (0.0020 in) US		1.514 — 1.522 mm (0.0596 — 0.0599 in)
		0.25 mm (0.0098 in) US		1.614 — 1.622 mm (0.0635 — 0.0639 in)
	Connecting rod bushing	Clearance between piston pin and bushing		STD
Limit				0.030 mm (0.0012 in)

GENERAL DESCRIPTION

MECHANICAL

Crankshaft	Bend limit		0.035 mm (0.0014 in)			
	Crank pin and crank journal	Out-of-roundness		0.005 mm (0.0002 in) or less		
		Grinding limit		0.25 mm (0.0098 in)		
	Crank pin outer diameter		STD	51.984 — 52.000 mm (2.0466 — 2.0472 in)		
			0.03 mm (0.0012 in) US	51.954 — 51.970 mm (2.0454 — 2.0461 in)		
			0.05 mm (0.0020 in) US	51.934 — 51.950 mm (2.0447 — 2.0453 in)		
			0.25 mm (0.0098 in) US	51.734 — 51.750 mm (2.0368 — 2.0374 in)		
	Crank journal outer diameter		#1, #3, #5	STD	59.992 — 60.008 mm (2.3619 — 2.3625 in)	
				0.03 mm (0.0012 in) US	59.962 — 59.978 mm (2.3607 — 2.3613 in)	
				0.05 mm (0.0020 in) US	59.942 — 59.958 mm (2.3599 — 2.3605 in)	
				0.25 mm (0.0098 in) US	59.742 — 59.758 mm (2.3520 — 2.3527 in)	
			#2, #4	STD	59.992 — 60.008 mm (2.3619 — 2.3625 in)	
				0.03 mm (0.0012 in) US	59.962 — 59.978 mm (2.3607 — 2.3613 in)	
				0.05 mm (0.0020 in) US	59.942 — 59.958 mm (2.3599 — 2.3605 in)	
				0.25 mm (0.0098 in) US	59.742 — 59.758 mm (2.3520 — 2.3527 in)	
	Thrust clearance		STD	0.030 — 0.115 mm (0.0012 — 0.0045 in)		
			Limit	0.25 mm (0.0098 in)		
	Oil clearance		#1	STD	0.003 — 0.030 mm (0.00012 — 0.0012 in)	
				Limit	0.040 mm (0.0016 in)	
			#2	STD	0.012 — 0.033 mm (0.0004 — 0.0012 in)	
Limit				0.045 mm (0.0018 in)		
#3			STD	0.003 — 0.030 mm (0.00012 — 0.0012 in)		
			Limit	0.040 mm (0.0016 in)		
#4			STD	0.012 — 0.033 mm (0.0004 — 0.0012 in)		
			Limit	0.045 mm (0.0018 in)		
#5			STD	0.010 — 0.031 mm (0.0004 — 0.0012 in)		
			Limit	0.040 mm (0.0016 in)		

GENERAL DESCRIPTION

MECHANICAL

Crankshaft main bearing	Crankshaft main bearing thickness	#1, #3	STD	1.998 — 2.011 mm (0.0787 — 0.0792 in)
			0.03 mm (0.0012 in) US	2.017 — 2.020 mm (0.0794 — 0.0795 in)
			0.05 mm (0.0020 in) US	2.027 — 2.030 mm (0.0798 — 0.0799 in)
			0.25 mm (0.0098 in) US	2.127 — 2.130 mm (0.0837 — 0.0839 in)
		#2, #4, #5	STD	2.000 — 2.013 mm (0.0787 — 0.0793 in)
			0.03 mm (0.0012 in) US	2.019 — 2.022 mm (0.0795 — 0.0796 in)
			0.05 mm (0.0020 in) US	2.029 — 2.032 mm (0.0799 — 0.0800 in)
			0.25 mm (0.0098 in) US	2.129 — 2.132 mm (0.0838 — 0.0839 in)

B: COMPONENT

1. TIMING BELT

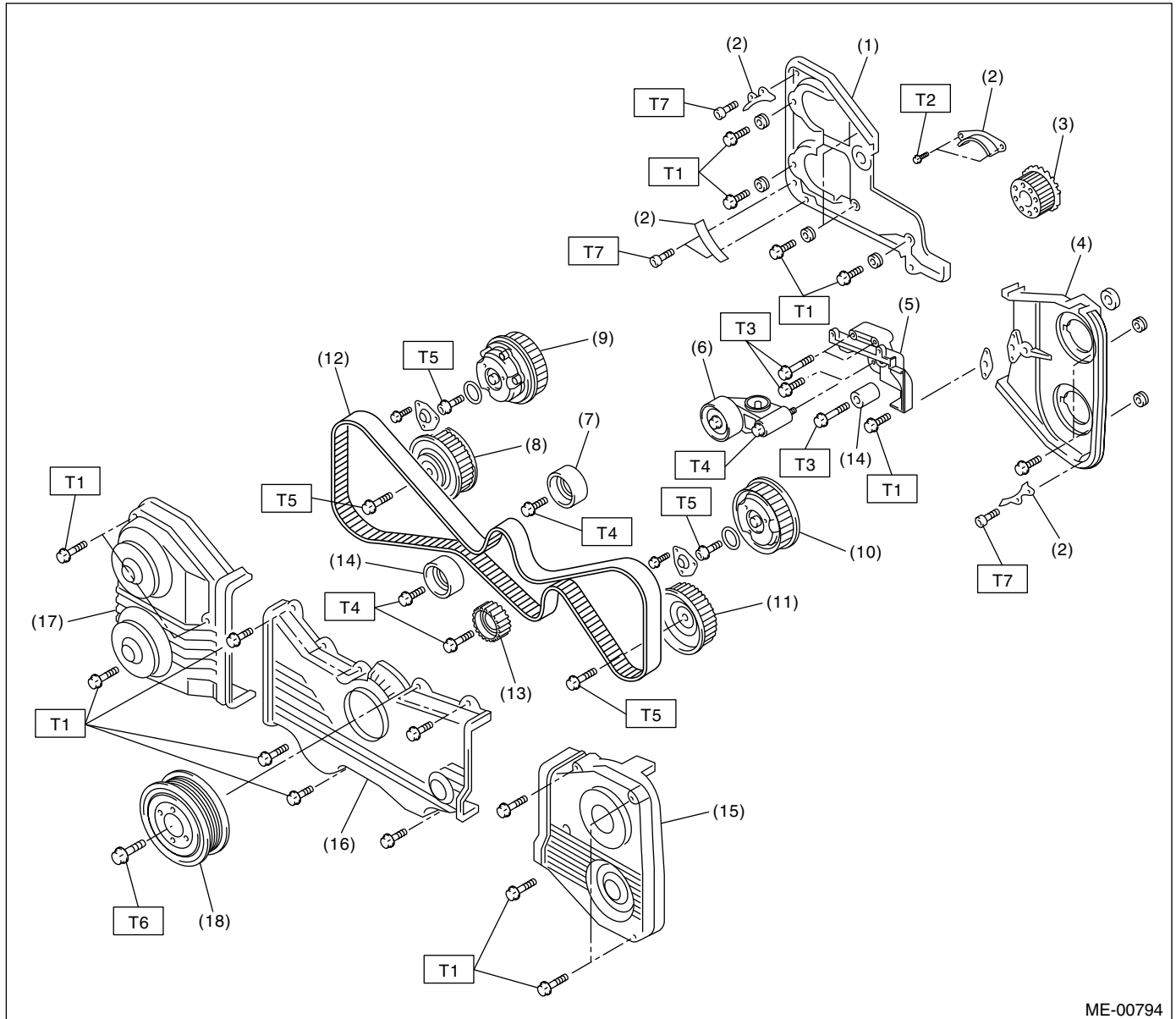

ME-00794

- | | |
|------------------------------------------|-------------------------------------|
| (1) Timing belt cover No. 2 (RH) | (11) Exhaust camshaft sprocket (LH) |
| (2) Timing belt guide (MT model) | (12) Timing belt |
| (3) Crankshaft sprocket | (13) Belt idler No. 2 |
| (4) Timing belt cover No. 2 (LH) | (14) Belt idler |
| (5) Tensioner bracket | (15) Timing belt cover (LH) |
| (6) Automatic belt tension adjuster ASSY | (16) Front belt cover |
| (7) Belt idler | (17) Timing belt cover (RH) |
| (8) Exhaust camshaft sprocket (RH) | (18) Crankshaft pulley |
| (9) Intake camshaft sprocket (RH) | |
| (10) Intake camshaft sprocket (LH) | |

Tightening torque: N·m (kgf·m, ft·lb)

T1: 5 (0.5, 3.6)

T2: 10 (1.0, 7)

T3: 25 (2.5, 18.1)

T4: 39 (4.0, 28.9)

T5: <Ref. to ME(H4DOTC)-58, INSTALLATION, CRANKSHAFT SPROCKET.>

T6: <Ref. to ME(H4DOTC)-47, INSTALLATION, CRANKSHAFT PULLEY.>

T7: 6.4 (0.65, 4.7)

GENERAL DESCRIPTION

MECHANICAL

2. CYLINDER HEAD AND CAMSHAFT

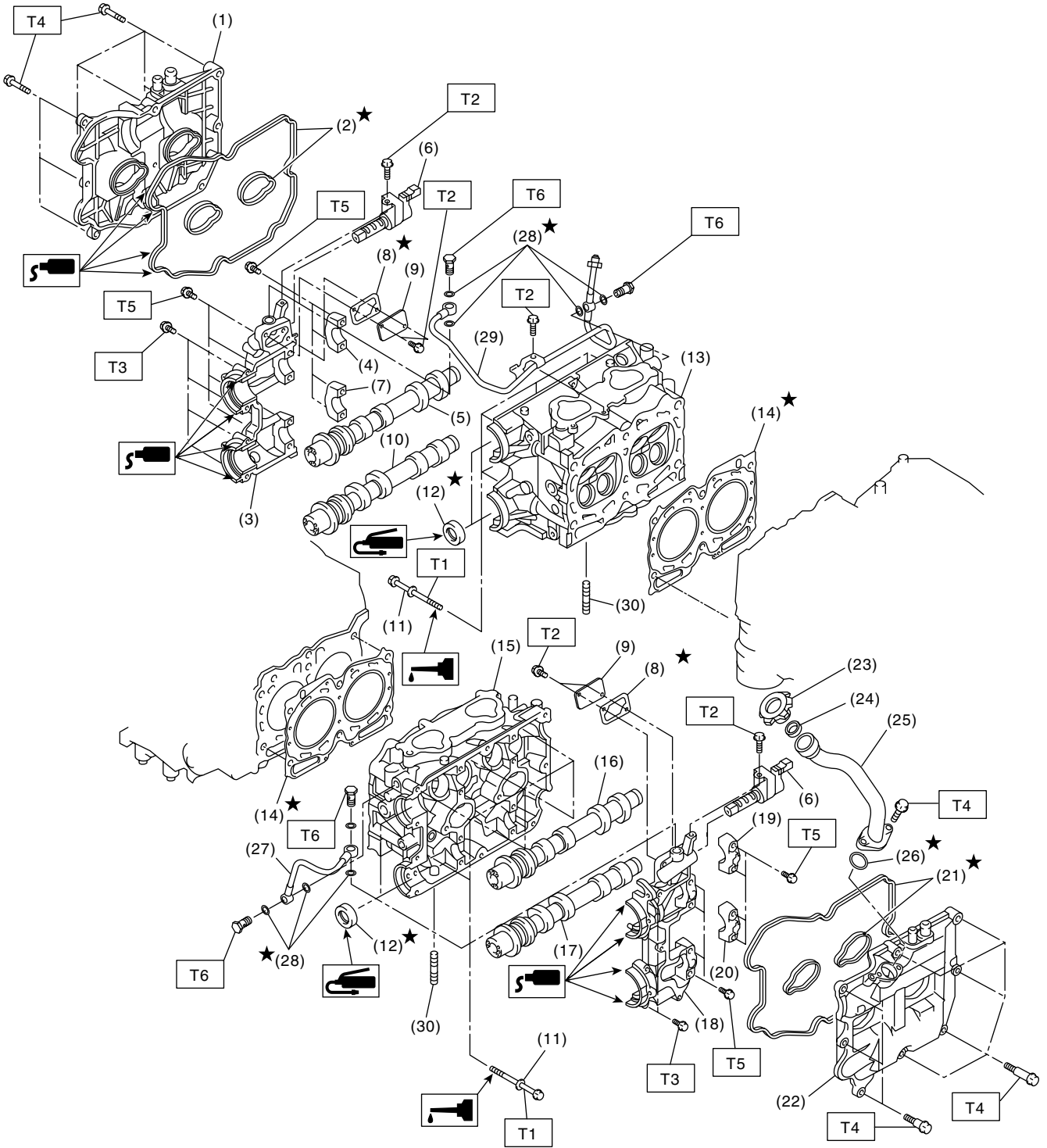

ME-00765

ME(H4DOTC)-8

GENERAL DESCRIPTION

MECHANICAL

-
- | | | |
|------------------------------------------|-------------------------------------|--------------------|
| (1) Rocker cover (RH) | (13) Cylinder head (RH) | (27) Oil pipe (LH) |
| (2) Rocker cover gasket (RH) | (14) Cylinder head gasket | (28) Gasket |
| (3) Camshaft cap (Front RH) | (15) Cylinder head (LH) | (29) Oil pipe (RH) |
| (4) Intake camshaft cap (RH) | (16) Intake camshaft (LH) | (30) Stud bolt |
| (5) Intake camshaft (RH) | (17) Exhaust camshaft (LH) | |
| (6) Variable valve timing solenoid valve | (18) Camshaft cap (Front LH) | |
| (7) Exhaust camshaft cap (Center RH) | (19) Intake camshaft cap (Rear LH) | |
| (8) Gasket | (20) Exhaust camshaft cap (Rear LH) | |
| (9) Oil return cover | (21) Rocker cover gasket (LH) | |
| (10) Exhaust camshaft (RH) | (22) Rocker cover (LH) | |
| (11) Cylinder head bolt | (23) Oil filler cap | |
| (12) Oil seal | (24) Gasket | |
| | (25) Oil filler duct | |
| | (26) O-ring | |

Tightening torque: N·m (kgf-m, ft-lb)

T1: <Ref. to ME(H4DOTC)-65, INSTALLATION, CYLINDER HEAD ASSEMBLY.>

T2: 8 (0.8, 5.9)

T3: 10 (1.0, 7)

T4: 6.4 (0.65, 4.7)

T5: 20 (2.0, 14.5)

T6: 29 (3.0, 21.4)

GENERAL DESCRIPTION

MECHANICAL

3. CYLINDER HEAD AND VALVE ASSEMBLY

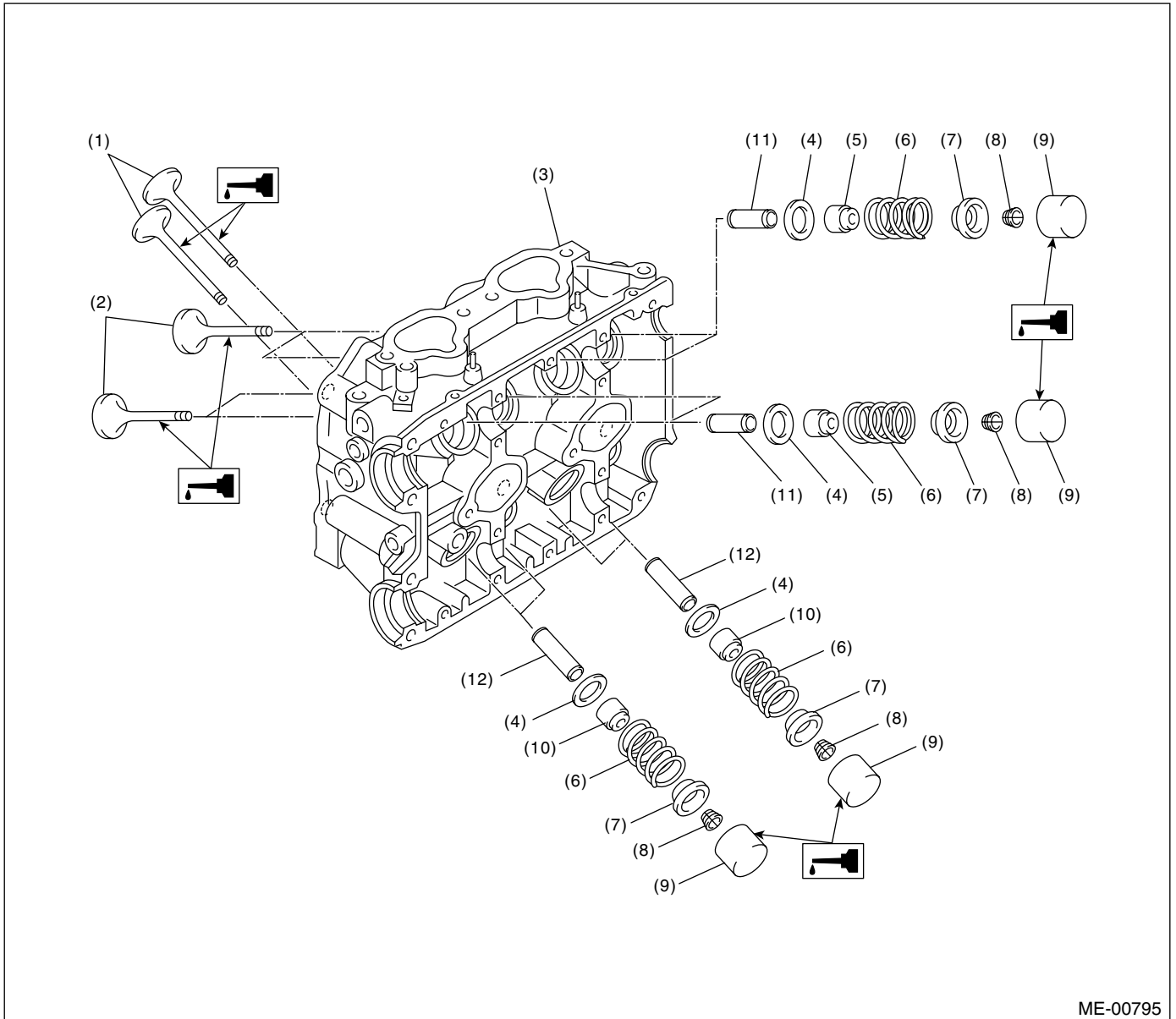

ME-00795

- (1) Exhaust valve
- (2) Intake valve
- (3) Cylinder head
- (4) Valve spring seat

- (5) Intake valve oil seal
- (6) Valve spring
- (7) Retainer
- (8) Retainer key

- (9) Valve lifter
- (10) Exhaust valve oil seal
- (11) Intake valve guide
- (12) Exhaust valve guide

GENERAL DESCRIPTION

MECHANICAL

MEMO:

GENERAL DESCRIPTION

MECHANICAL

4. CYLINDER BLOCK

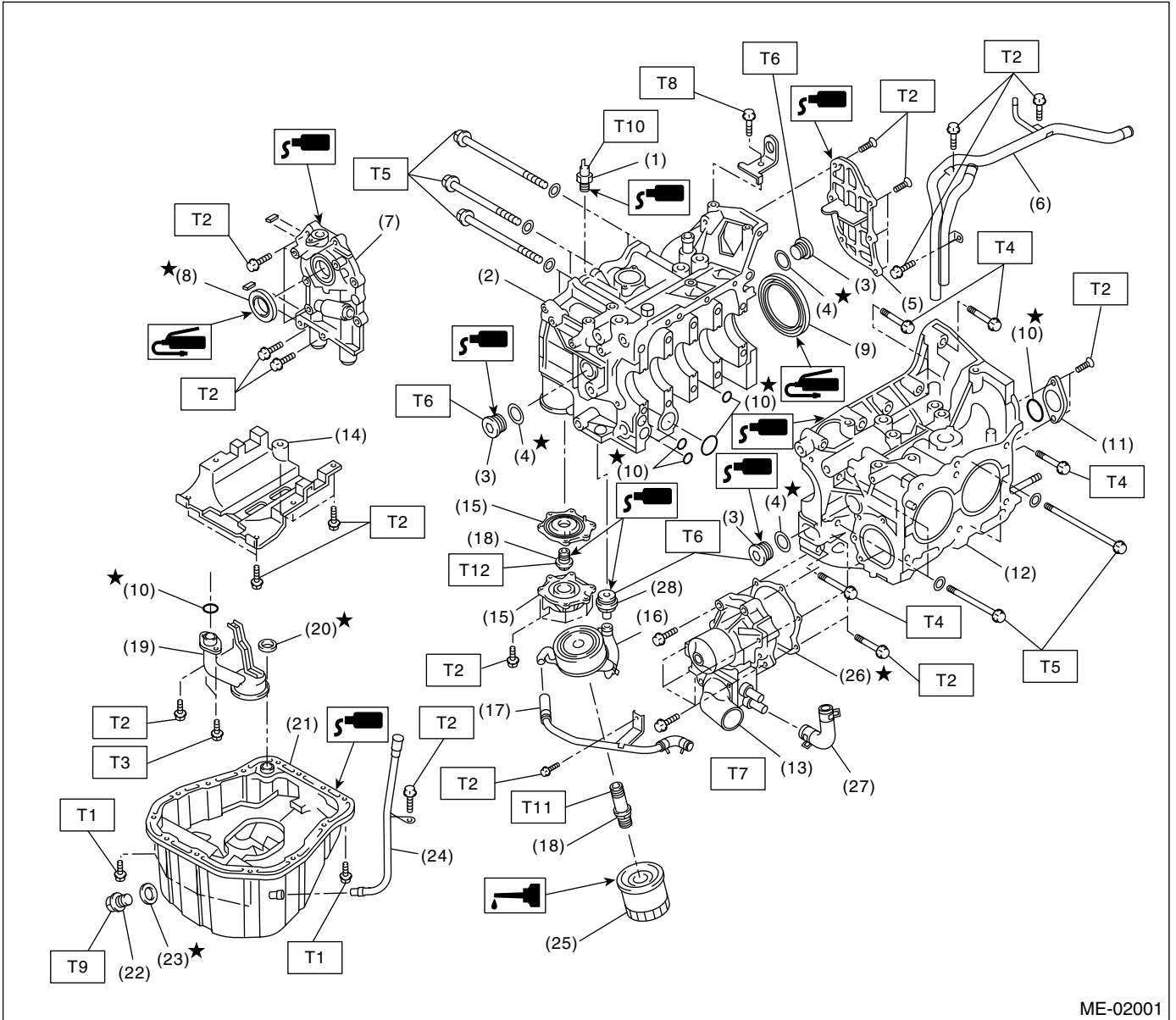

ME-02001

GENERAL DESCRIPTION

MECHANICAL

(1) Oil pressure switch	(16) Oil cooler	Tightening torque: N-m (kgf-m, ft-lb)
(2) Cylinder block (RH)	(17) Water by-pass pipe	T1: 5 (0.5, 3.6)
(3) Service hole plug	(18) Connector	T2: 6.4 (0.65, 4.7)
(4) Gasket	(19) Oil strainer	T3: 10 (1.0, 7.2)
(5) Oil separator cover	(20) Gasket	T4: 25 (2.5, 18.1)
(6) Water by-pass pipe	(21) Oil pan	T5: <Ref. to ME(H4DOTC)-76, INSTALLATION, CYLINDER BLOCK.>
(7) Oil pump	(22) Drain plug	T6: 70 (7.1, 50.6)
(8) Front oil seal	(23) Metal gasket	T7: First 12 (1.2, 8.7) Second 12 (1.2, 8.7)
(9) Rear oil seal	(24) Oil level gauge guide	T8: 16 (1.6, 11.6)
(10) O-ring	(25) Oil filter	T9: 44 (4.5, 33)
(11) Service hole cover	(26) Gasket	T10: 25 (2.5, 18.1)
(12) Cylinder block (LH)	(27) Water pump hose	T11: 54 (5.5, 40)
(13) Water pump	(28) Plug	T12: 45 (4.6, 33)
(14) Baffle plate		
(15) Adapter		

GENERAL DESCRIPTION

MECHANICAL

5. CRANKSHAFT AND PISTON

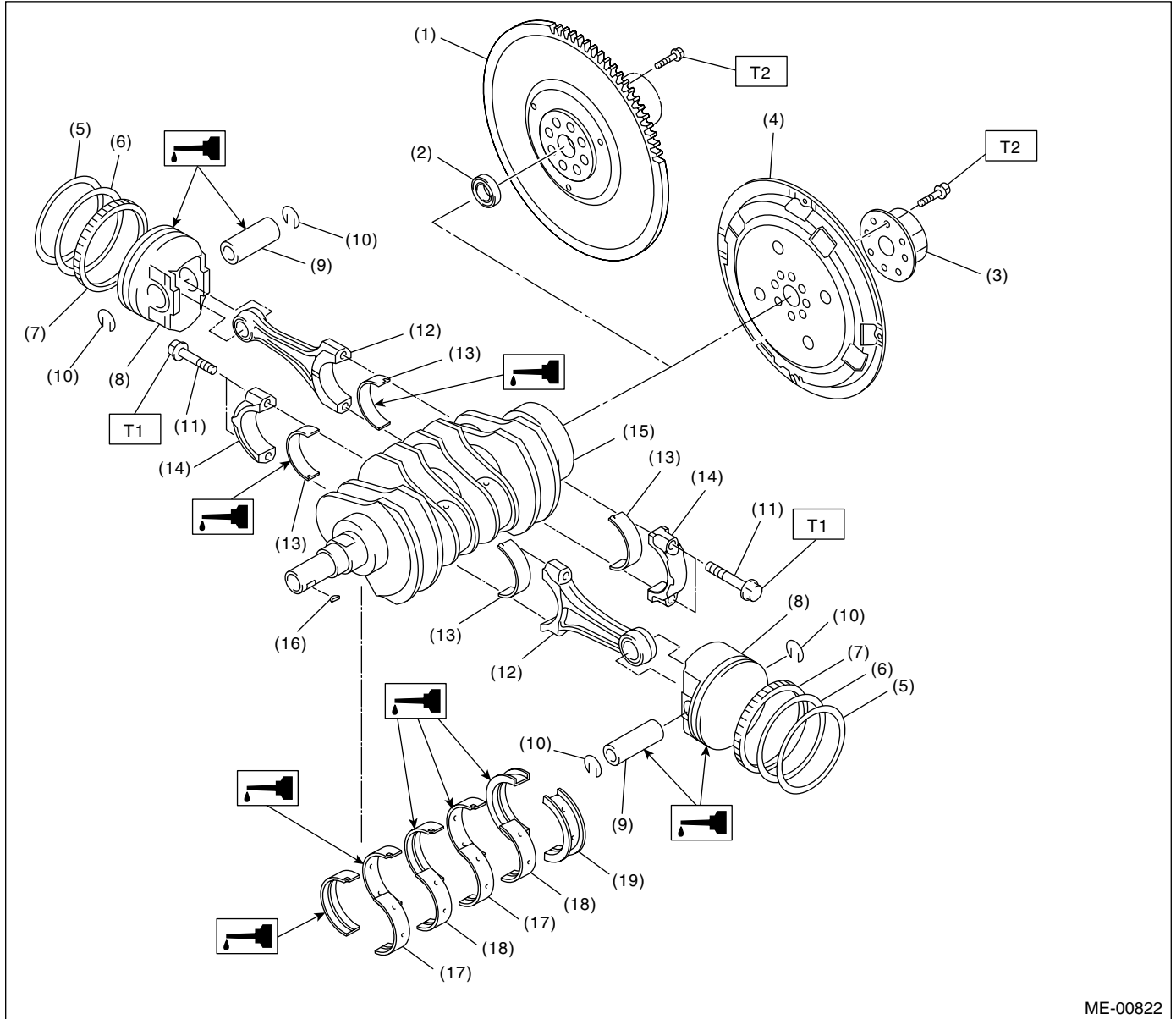

ME-00822

- | | | |
|------------------------------|-----------------------------|--------------------------------|
| (1) Flywheel (MT model) | (9) Piston pin | (17) Crankshaft bearing #1, #3 |
| (2) Ball bearing (MT model) | (10) Circlip | (18) Crankshaft bearing #2, #4 |
| (3) Reinforcement (AT model) | (11) Connecting rod bolt | (19) Crankshaft bearing #5 |
| (4) Drive plate (AT model) | (12) Connecting rod | |
| (5) Top ring | (13) Connecting rod bearing | |
| (6) Second ring | (14) Connecting rod cap | |
| (7) Oil ring | (15) Crankshaft | |
| (8) Piston | (16) Woodruff key | |

Tightening torque: N·m (kgf·m, ft·lb)

T1: 52 (5.3, 38.4)

T2: 72 (7.3, 52.8)

6. ENGINE MOUNTING

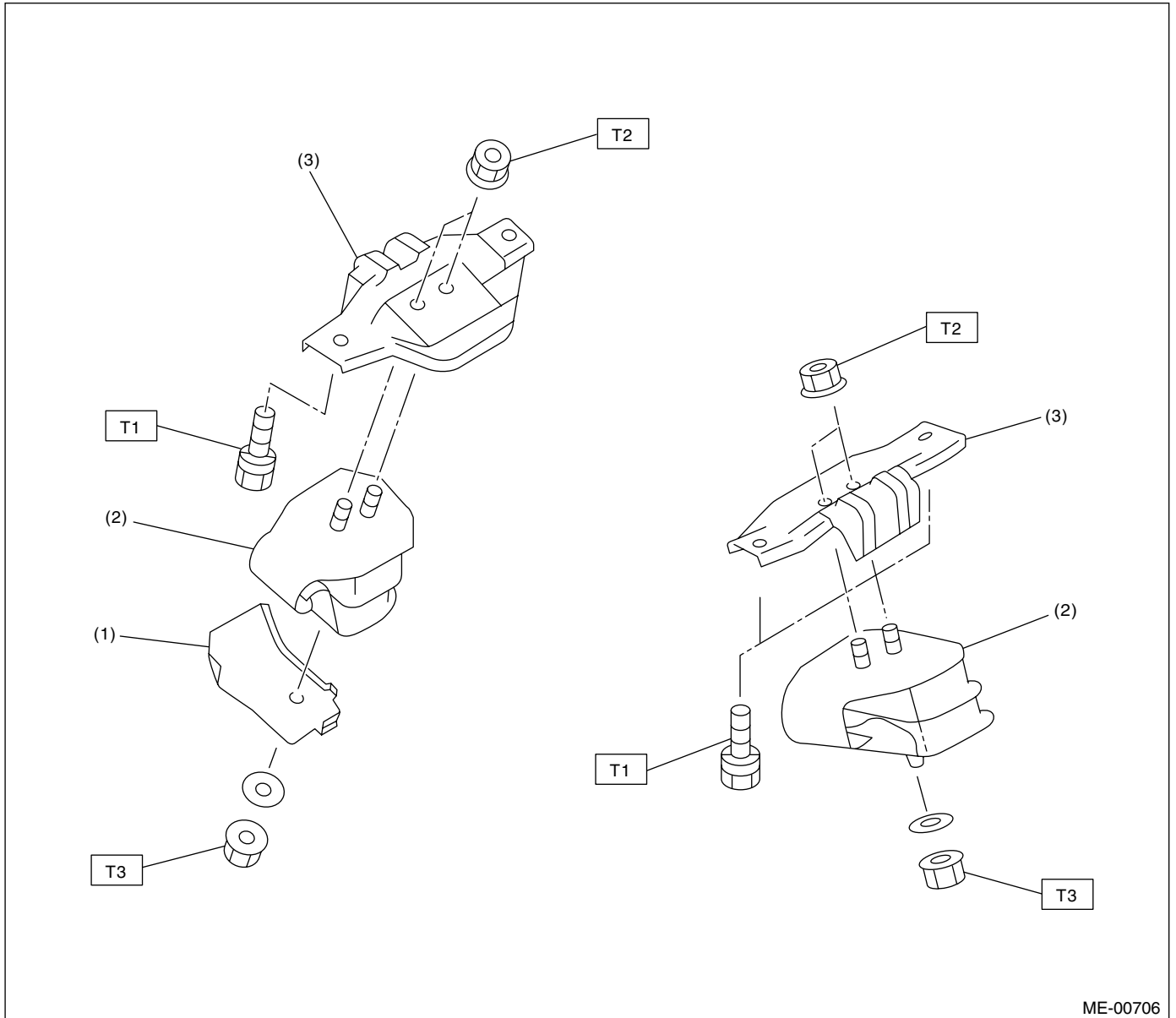

ME-00706

- (1) Heat shield cover
- (2) Front cushion rubber

- (3) Front engine mounting bracket

Tightening torque: N·m (kgf-m, ft-lb)

T1: 35 (3.6, 25.8)

T2: 42 (4.3, 30.9)

T3: 85 (8.7, 62.7)

GENERAL DESCRIPTION

MECHANICAL

C: CAUTION

- Wear working clothing, including a cap, protective goggles, and protective shoes during operation.
- Remove contamination including dirt and corrosion before removal, installation or disassembly.
- Keep the disassembled parts in order and protect them from dust or dirt.
- Before removal, installation or disassembly, be sure to clarify the failure. Avoid unnecessary removal, installation, disassembly, and replacement.
- Be careful not to burn your hands, because each part in the vehicle is hot after running.
- Be sure to tighten fasteners including bolts and nuts to the specified torque.
- Place shop jacks or safety stands at the specified points.
- Before disconnecting electrical connectors of sensors or units, be sure to disconnect the ground cable from battery.
- All parts should be thoroughly cleaned, paying special attention to the engine oil passages, pistons and bearings.
- Rotating parts and sliding parts such as piston, bearing and gear should be coated with oil prior to assembly.
- Be careful not to let oil, grease or coolant contact the timing belt, clutch disc and flywheel.
- All removed parts, if to be reused, should be reinstalled in the original positions and directions.
- Bolts, nuts and washers should be replaced with new ones as required.
- Even if necessary inspections have been made in advance, proceed with assembly work while making rechecks.
- Remove or install the engine in an area where chain hoists, lifting devices, etc. are available for ready use.
- Be sure not to damage coated surfaces of body panels with tools or stain seats and windows with coolant or oil. Place a cover over fenders, as required, for protection.
- Prior to starting work, prepare the following: Service tools, clean cloth, containers to catch coolant and oil, wire ropes, chain hoist, transmission jacks, etc.
- Lift-up or lower the vehicle when necessary. Make sure to support the correct positions.

GENERAL DESCRIPTION

MECHANICAL

D: PREPARATION TOOL

1. SPECIAL TOOLS

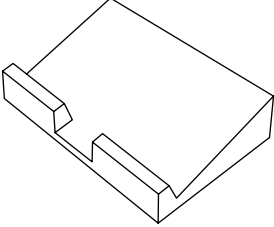
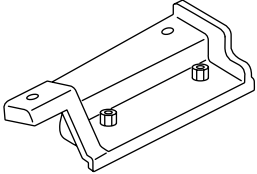
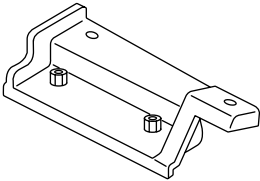
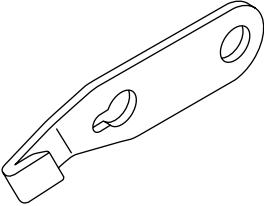
ILLUSTRATION	TOOL NUMBER	DESCRIPTION	REMARKS
 <p data-bbox="331 661 472 683">ST-498267600</p>	498267600	CYLINDER HEAD TABLE	<ul style="list-style-type: none"> • Used for replacing valve guides. • Used for removing and installing valve springs.
 <p data-bbox="331 1034 472 1055">ST-498457000</p>	498457000	ENGINE STAND ADAPTER RH	Used with ENGINE STAND (499817000).
 <p data-bbox="331 1415 472 1436">ST-498457100</p>	498457100	ENGINE STAND ADAPTER LH	Used with ENGINE STAND (499817000).
 <p data-bbox="331 1789 472 1810">ST-498497100</p>	498497100	CRANKSHAFT STOPPER	Used for stopping rotation of flywheel when loosening and tightening crankshaft pulley bolt, etc.

GENERAL DESCRIPTION

MECHANICAL

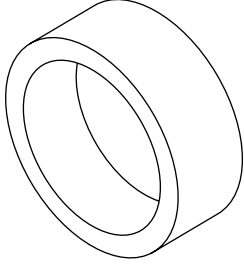
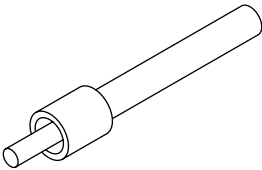
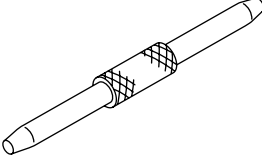
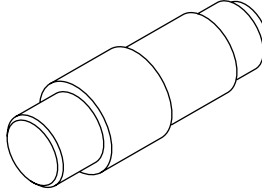
ILLUSTRATION	TOOL NUMBER	DESCRIPTION	REMARKS
 <p style="text-align: center;">ST-498747300</p>	498747300	PISTON GUIDE	Used for installing piston in cylinder for 2.5 L engine.
 <p style="text-align: center;">ST-498857100</p>	498857100	VALVE OIL SEAL GUIDE	Used for press-fitting of intake and exhaust valve guide oil seals.
 <p style="text-align: center;">ST-499017100</p>	499017100	PISTON PIN GUIDE	Used for installing piston pin, piston and connecting rod.
 <p style="text-align: center;">ST-499037100</p>	499037100	CONNECTING ROD BUSHING REMOVER & INSTALLER	Used for removing and installing connecting rod bushing.

GENERAL DESCRIPTION

MECHANICAL

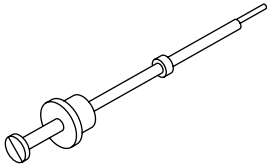
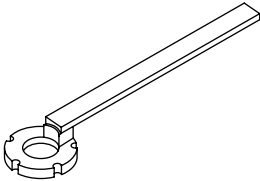
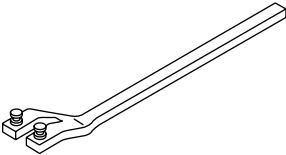
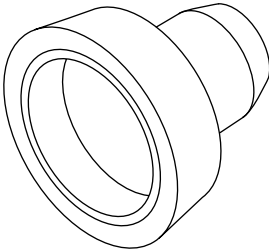
ILLUSTRATION	TOOL NUMBER	DESCRIPTION	REMARKS
 <p style="text-align: center;">ST-499097700</p>	499097700	PISTON PIN REMOVER ASSY	Used for removing piston pin.
 <p style="text-align: center;">ST-499207400</p>	499207400	CAMSHAFT SPROCKET WRENCH	Used for removing and installing exhaust camshaft sprocket.
 <p style="text-align: center;">ST-499977500</p>	499977500	CAMSHAFT SPROCKET WRENCH	Used for removing and installing intake camshaft sprocket.
 <p style="text-align: center;">ST-499587200</p>	499587200	CRANKSHAFT OIL SEAL INSTALLER	<ul style="list-style-type: none"> • Used for installing crankshaft oil seal. • Used with CRANKSHAFT OIL SEAL GUIDE (499597100).

GENERAL DESCRIPTION

MECHANICAL

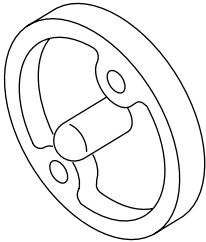
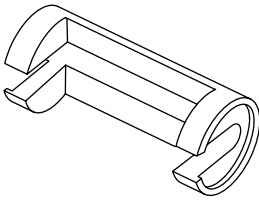
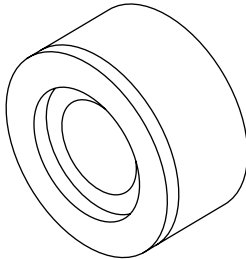
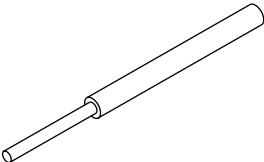
ILLUSTRATION	TOOL NUMBER	DESCRIPTION	REMARKS
 <p style="text-align: center;">ST-499597100</p>	499597100	CRANKSHAFT OIL SEAL GUIDE	<ul style="list-style-type: none"> • Used for installing crankshaft oil seal. • Used with CRANKSHAFT OIL SEAL INSTALLER (499587200).
 <p style="text-align: center;">ST-499718000</p>	499718000	VALVE SPRING REMOVER	Used for removing and installing valve spring.
 <p style="text-align: center;">ST18251AA020</p>	18251AA020	VALVE GUIDE ADJUSTER	Used for installing intake and exhaust valve guides.
 <p style="text-align: center;">ST-499767200</p>	499767200	VALVE GUIDE REMOVER	Used for removing valve guides.

GENERAL DESCRIPTION

MECHANICAL

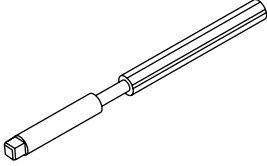
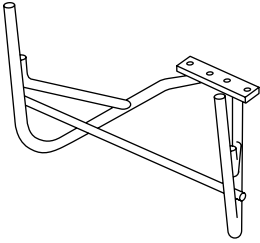
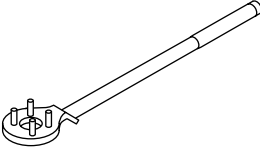
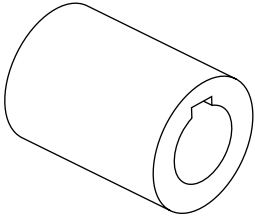
ILLUSTRATION	TOOL NUMBER	DESCRIPTION	REMARKS
 <p style="text-align: center;">ST-499767400</p>	499767400	VALVE GUIDE REAMER	Used for reaming valve guides.
 <p style="text-align: center;">ST-499817000</p>	499817000	ENGINE STAND	<ul style="list-style-type: none"> • Stand used for engine disassembly and assembly. • Used with ENGINE STAND ADAPTER RH (498457000) & LH (498457100).
 <p style="text-align: center;">ST-499977100</p>	499977100	CRANKSHAFT PULLEY WRENCH	Used for stopping rotation of crankshaft pulley when loosening and tightening crankshaft pulley bolts.
 <p style="text-align: center;">ST-499987500</p>	499987500	CRANKSHAFT SOCKET	Used for rotating crankshaft.

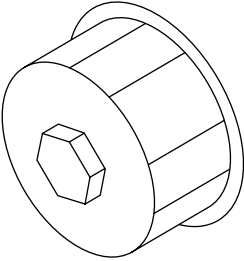
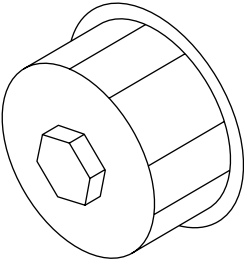
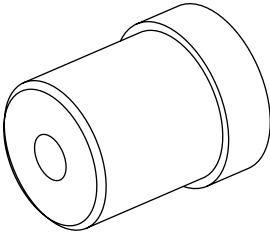
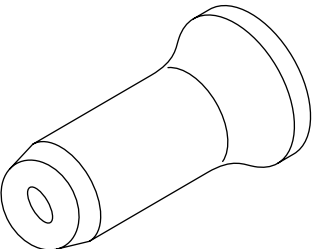

GENERAL DESCRIPTION

MECHANICAL

ILLUSTRATION	TOOL NUMBER	DESCRIPTION	REMARKS
 <p style="text-align: center;">ST18332AA000</p>	18332AA000	OIL FILTER WRENCH	Used for removing and installing the oil filter. (Outer diameter : 68 mm (2.68 in))
 <p style="text-align: center;">ST18332AA000</p>	18332AA010	OIL FILTER WRENCH	Used for removing and installing the oil filter. (Outer diameter : 65 mm (2.56 in))
 <p style="text-align: center;">ST-499587100</p>	499587100	OIL SEAL INSTALLER	Used for installing oil pump oil seal.
 <p style="text-align: center;">ST-499587600</p>	499587600	OIL SEAL INSTALLER	Used for installing camshaft oil seal for DOHC engine.

GENERAL DESCRIPTION

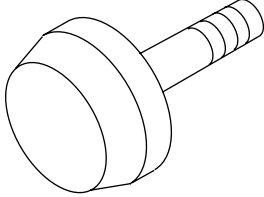
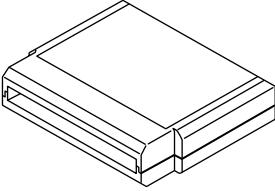
MECHANICAL

ILLUSTRATION	TOOL NUMBER	DESCRIPTION	REMARKS
 ST-499597200	499597200	OIL SEAL GUIDE	<ul style="list-style-type: none"> • Used for installing camshaft oil seal for DOHC engine. • Used with OIL SEAL GUIDE (499587600).
 ST24082AA230	24082AA230 (Newly adopted tool)	CARTRIDGE	Troubleshooting for electrical systems.
 ST22771AA030	22771AA030	SUBARU SELECT MONI- TOR KIT	Troubleshooting for electrical systems.

2. GENERAL PURPOSE TOOLS

TOOL NAME	REMARKS
Compression Gauge	Used for measuring compression.

E: PROCEDURE

It is possible to conduct the following service procedures with engine on the vehicle, however, the procedures described in this section are based on the condition that the engine is removed from the vehicle.

- V-belt
- Timing Belt
- Camshaft
- Cylinder Head

2. Compression

A: INSPECTION

CAUTION:

After warming-up, engine becomes very hot. Be careful not to burn yourself during measurement.

- 1) After warming-up the engine, turn the ignition switch to OFF.
- 2) Make sure that the battery is fully charged.
- 3) Release the fuel pressure. <Ref. to FU(H4DOTC)-48, RELEASING OF FUEL PRESSURE, OPERATION, Fuel.>
- 4) Remove all the spark plugs. <Ref. to IG(H4DOTC)-5, REMOVAL, Spark Plug.>
- 5) Fully open the throttle valve.
- 6) Check the starter motor for satisfactory performance and operation.
- 7) Hold the compression gauge tight against spark plug hole.

NOTE:

When using a screw-in type compression gauge, the screw (put into cylinder head spark plug hole) should be less than 18 mm (0.71 in) long.

- 8) Crank the engine by means of starter motor, and then read the maximum value on the gauge when the pointer is steady.

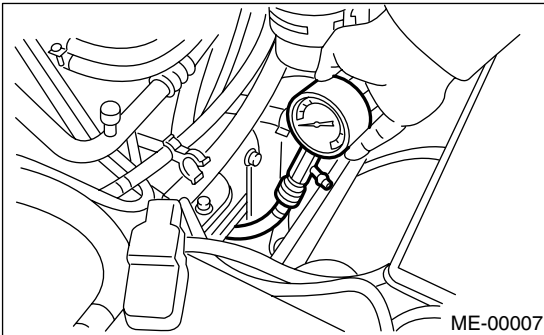

- 9) Perform at least two measurements per cylinder, and make sure that the values are correct.

Compression (350 rpm and fully open throttle):

Standard

981 — 1,177 kPa (10 — 12 kgf/cm², 142 — 171 psi)

Limit

882 kPa (9.0 kgf/cm², 128 psi)

Difference between cylinders

Less than 49 kPa (0.5 kgf/cm², 7 psi)

3. Idle Speed

A: INSPECTION

1. USING SUBARU SELECT MONITOR

1) Before checking the idle speed, check the following:

(1) Ensure the air cleaner element is free from clogging, ignition timing is correct, spark plugs are in good condition, and that the hoses are connected properly.

(2) Ensure the malfunction indicator light does not illuminate.

2) Warm-up the engine.

3) Stop the engine, and then turn the ignition switch to OFF.

4) Insert the cartridge to SUBARU SELECT MONITOR.

5) Connect the SUBARU SELECT MONITOR to data link connector.

6) Turn the ignition switch to ON, and SUBARU SELECT MONITOR switch to ON.

7) Select the {2. Each System Check} in Main Menu.

8) Select the {Engine Control System} in Selection Menu.

9) Select the {1. Current Data Display & Save} in Engine Control System Diagnosis.

10) Select the {1.12 Data Display} in Data Display Menu.

11) Start the engine, and then read the engine idle speed.

12) Check the idle speed when unloaded. (With headlights, heater fan, rear defroster, radiator fan, air conditioning, etc. OFF)

Idle speed [No load and gears in neutral]:

700±100 rpm

13) Check the idle speed when loaded. (Turn the air conditioning switch to “ON” and operate the compressor for at least 1 minute before measurement.)

Idle speed [A/C “ON”, no load and gears in neutral]:

- ***A/C refrigerant pressure is low***

MT: 725±100 rpm

AT: 750±100 rpm

- ***A/C refrigerant pressure is high***

MT: 800±100 rpm

AT: 825±100 rpm

NOTE:

As idle speed is controlled by the automatic adjustment type, it can not be adjusted manually. If the idle speed is out of specifications, refer to General On-board Diagnosis Table under “Engine Control System”. <Ref. to EN(H4DOTC)-439, General Diagnostic Table.>

4. Ignition Timing

A: INSPECTION

1. USING SUBARU SELECT MONITOR

1) Before checking the ignition timing speed, check the following:

(1) Ensure the air cleaner element is free from clogging, spark plugs are in good condition, and that hoses are connected properly.

(2) Ensure the malfunction indicator light does not illuminate.

2) Warm-up the engine.

3) Stop the engine, and then turn the ignition switch to OFF.

4) Insert the cartridge to SUBARU SELECT MONITOR.

5) Connect the SUBARU SELECT MONITOR to data link connector.

6) Turn the ignition switch to ON, and SUBARU SELECT MONITOR switch to ON.

7) Select the {2. Each System Check} in Main Menu.

8) Select the {Engine Control System} in Selection Menu.

9) Select the {1. Current Data Display & Save} in Engine Control System Diagnosis.

10) Select the {1.12 Data Display} in Data Display Menu.

11) Start the engine and check the ignition timing at idle speed.

Ignition timing [BTDC/rpm]:

MT model:

$13^{\circ} \pm 10^{\circ}$

AT model:

$17^{\circ} \pm 10^{\circ}$

If the timing is not correct, check the ignition control system. Refer to Engine Control System. <Ref. to EN(H4DOTC)-2, Basic Diagnostic Procedure.>

5. Intake Manifold Vacuum

A: INSPECTION

- 1) Warm-up the engine.
- 2) Disconnect the brake vacuum hose, and then install the vacuum gauge to hose fitting on manifold.
- 3) Keep the engine at the idle speed, and then read the vacuum gauge indication.

By observing the gauge needle movement, the internal condition of engine can be diagnosed as described below.

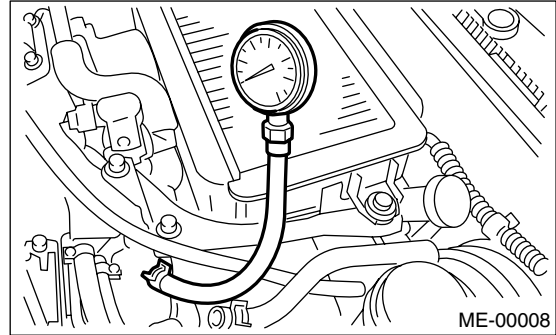

Vacuum pressure (at idling, A/C "OFF"):
Less than -60.0 kPa (-450 mmHg, -17.72 inHg)

Diagnosis of engine condition by measurement of manifold vacuum	
Vacuum gauge indication	Possible engine condition
1. Needle is steady but lower than normal position. This tendency becomes more evident as engine temperature rises.	Leakage around intake manifold gasket or disconnection or damaged vacuum hose
2. When engine speed is reduced slowly from higher speed, needle stops temporarily when it is lowering or becomes steady above normal position.	Back pressure too high, or exhaust system clogged
3. Needle intermittently drops to position lower than normal position.	Leakage around cylinder
4. Needle drops suddenly and intermittently from normal position.	Sticky valves
5. When engine speed is gradually increased, needle begins to vibrate rapidly at certain speed, and then vibration increases as engine speed increases.	Weak or broken valve springs
6. Needle vibrates above and below normal position in narrow range.	Defective ignition system or throttle chamber idle adjustment

6. Engine Oil Pressure

A: INSPECTION

- 1) Remove the oil pressure switch from engine cylinder block. <Ref. to LU(H4DOTC)-18, Oil Pressure Switch.>
- 2) Connect the oil pressure gauge hose to cylinder block.
- 3) Connect the battery ground cable to battery.

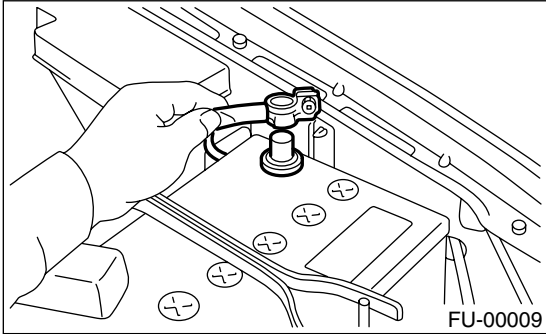

- 4) Start the engine, and then measure the oil pressure.

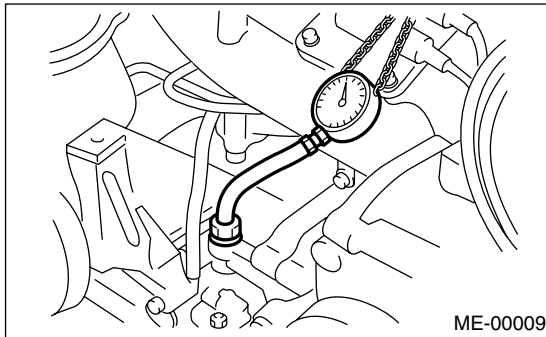

Oil pressure:

98 kPa (1.0 kgf/cm², 14 psi) or more at 800 rpm

294 kPa (3.0 kgf/cm², 43 psi) or more at 5,000 rpm

- If the oil pressure is out of specification, check oil pump, oil filter and lubrication line. <Ref. to LU(H4DOTC)-22, INSPECTION, Engine Lubrication System Trouble in General.>
- If the oil pressure warning light is turned ON and oil pressure is in specification, replace the oil pressure switch. <Ref. to LU(H4DOTC)-18, Oil Pressure Switch.>

NOTE:

The specified data is based on an engine oil temperature of 80°C (176°F).

- 5) After measuring the oil pressure, install the oil pressure switch. <Ref. to LU(H4DOTC)-18, INSTALLATION, Oil Pressure Switch.>

Tightening torque:

25 N·m (2.5 kgf-m, 18.1 ft-lb)

7. Fuel Pressure

A: INSPECTION

CAUTION:

Before removing the fuel pressure gauge, release the fuel pressure.

NOTE:

If out of specification, check or replace the pressure regulator and pressure regulator vacuum hose.

1) Release the fuel pressure. <Ref. to FU(H4DOTC)-48, RELEASING OF FUEL PRESSURE, OPERATION, Fuel.>

2) Open the fuel flap lid, and then remove the fuel filler cap.

3) Disconnect the fuel delivery hoses, and then connect the fuel pressure gauge.

4) Connect the connector of fuel pump relay.

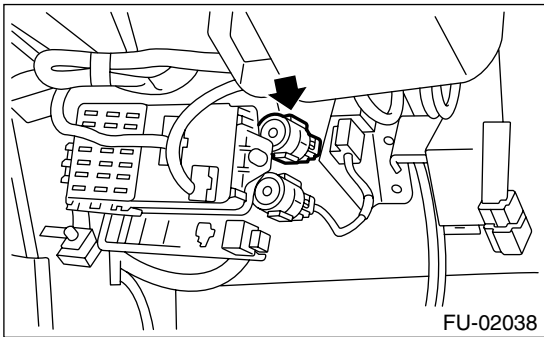

5) Start the engine.

6) Measure the fuel pressure while disconnecting the pressure regulator vacuum hose from intake manifold.

Fuel pressure:

Standard; 284 — 314 kPa (2.9 — 3.2 kgf/cm², 41 — 46 psi)

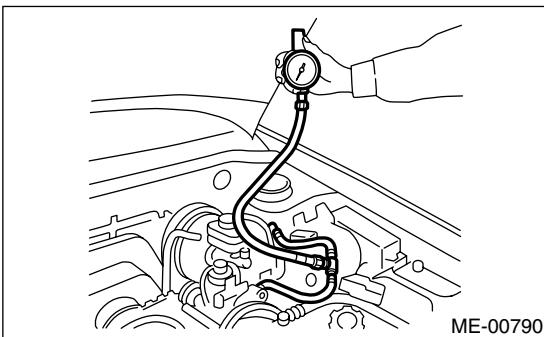

7) After connecting the pressure regulator vacuum hose, measure the fuel pressure.

Fuel pressure:

Standard; 230 — 260 kPa (2.35 — 2.65 kgf/cm², 33 — 38 psi)

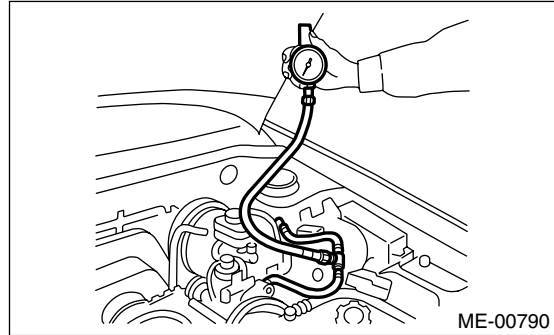

NOTE:

The fuel pressure gauge registers 10 to 20 kPa (0.1 to 0.2 kgf/cm², 1 to 3 psi) higher than standard values during high-altitude operations.

VALVE CLEARANCE

MECHANICAL

8. Valve Clearance

A: INSPECTION

Inspection and adjustment of the valve clearance should be performed while engine is cold.

- 1) Set the vehicle on a lift.
- 2) Disconnect the ground cable from battery.

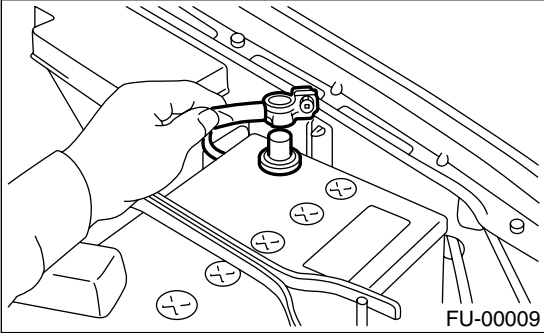

- 3) Remove the air intake duct. <Ref. to IN(H4DOTC)-8, REMOVAL, Air Intake Duct.>
- 4) Remove the bolts which secure the timing belt cover (RH).
- 5) Lift-up the vehicle.
- 6) Remove the under cover.
- 7) Loosen the remaining bolts which secure the timing belt cover (RH), and then remove the timing belt cover.
- 8) Lower the vehicle.
- 9) When inspecting the #1 and #3 cylinders:
 - (1) Pull out the engine harness connector with bracket from air cleaner upper cover.

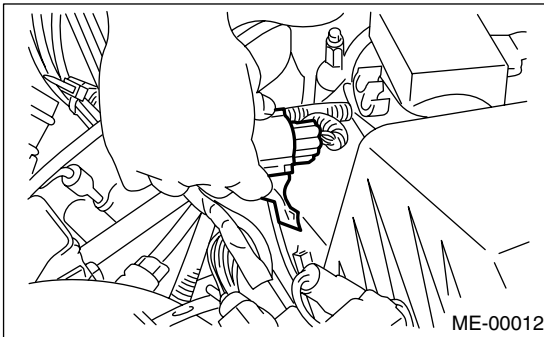

- (2) Remove the air cleaner case. <Ref. to IN(H4DOTC)-7, REMOVAL, Air Cleaner.>
 - (3) Disconnect the ignition coil connector.
 - (4) Remove the ignition coil.
 - (5) Place a suitable container under the vehicle.
 - (6) Disconnect the PCV hose from rocker cover (RH).
 - (7) Remove the bolts, and then remove the rocker cover (RH).
- 10) When inspecting the #2 and #4 cylinders:

- (1) Disconnect the battery cable, and then remove the battery and battery carrier.

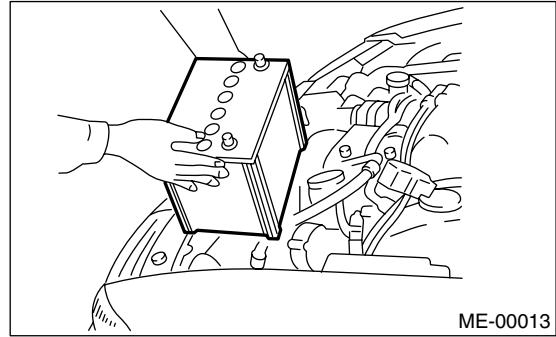

- (2) Remove the bolt which secures the engine harness bracket onto body.

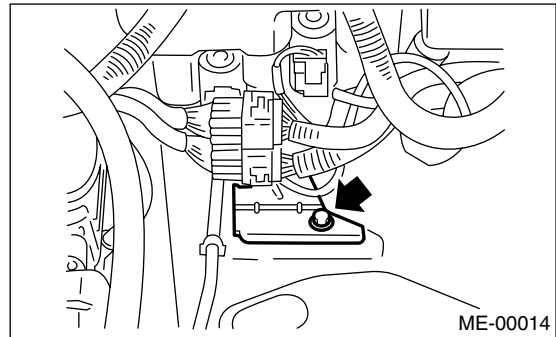

- (3) Disconnect the washer motor connectors.

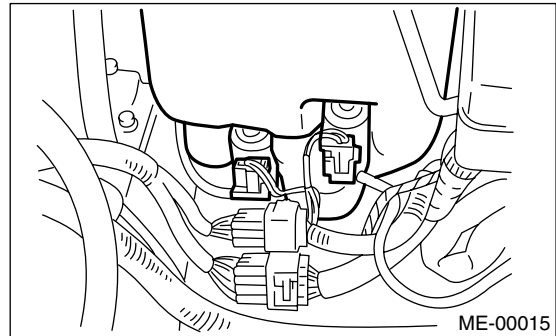

- (4) Remove the washer tank mounting bolts.

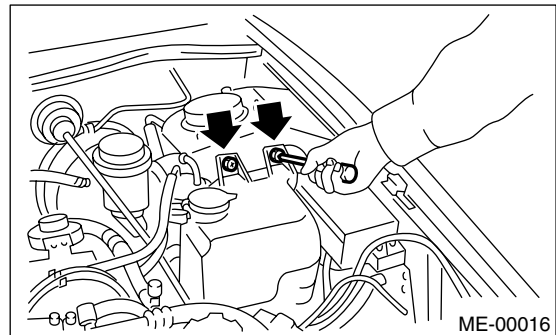

(5) Move the washer tank upward.

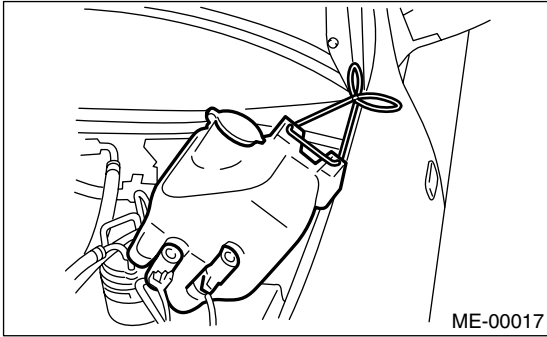

- (6) Disconnect the ignition coil connector.
- (7) Remove the ignition coil.
- (8) Place a suitable container under the vehicle.
- (9) Disconnect the PCV hose from rocker cover (LH).
- (10) Remove the bolts, and then remove the rocker cover (LH).

11) Turn the crankshaft pulley clockwise until arrow mark on the camshaft sprocket is set to position shown in the figure.

NOTE:

Turn the crankshaft using socket wrench.

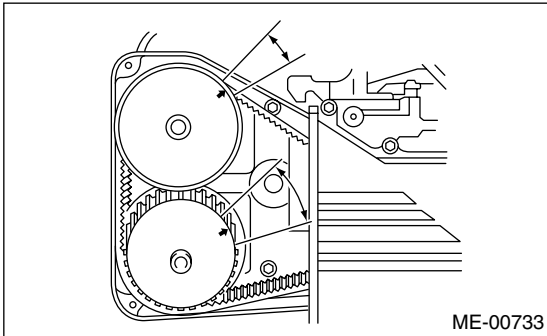

12) Measure the #1 cylinder intake valve and #3 cylinder exhaust valve clearance by using thickness gauge (A).

NOTE:

- Insert the thickness gauge in as horizontal a direction as possible with respect to the shim.
- Measure the exhaust valve clearances while lifting-up the vehicle.

Valve clearance:

Intake:

$$0.20^{+0.04}_{-0.06} \text{ mm } (0.0079^{+0.0016}_{-0.024} \text{ in})$$

Exhaust:

$$0.35 \pm 0.05 \text{ mm } (0.0138 \pm 0.0020 \text{ in})$$

NOTE:

If the measured value is not within specification, take notes of the value in order to adjust the valve clearance later on.

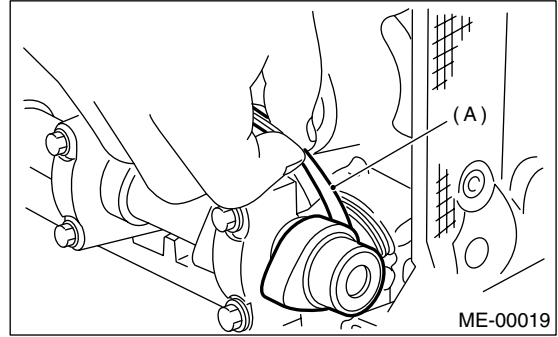

13) If necessary, adjust the valve clearance. <Ref. to ME(H4DOTC)-32, ADJUSTMENT.>

14) Further turn the crankshaft pulley clockwise. Using the same procedures described previously, and then measure the valve clearances again.

(1) Set the arrow mark on camshaft sprocket to position shown in the figure, and then measure the #2 cylinder exhaust valve and #3 cylinder intake valve clearances.

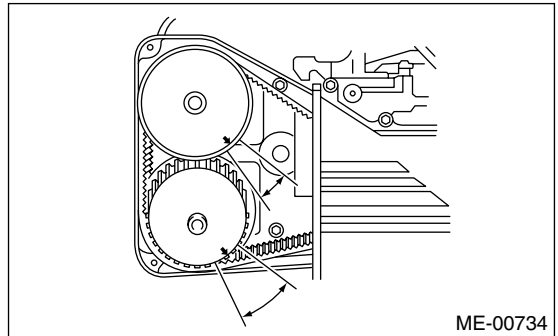

(2) Set the arrow mark on camshaft sprocket to position shown in the figure, and then measure the #2 cylinder intake valve and #4 cylinder exhaust valve clearances.

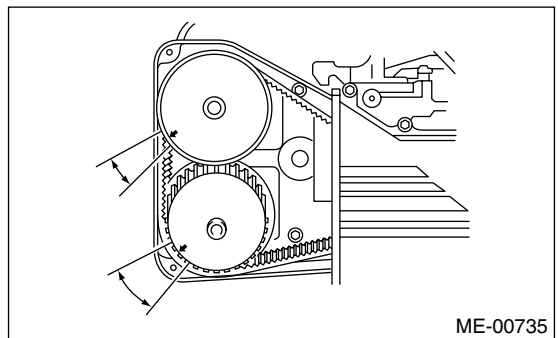

VALVE CLEARANCE

MECHANICAL

(3) Set the arrow mark on camshaft sprocket to position shown in the figure, and then measure the #1 cylinder exhaust valve and #4 cylinder intake valve clearances.

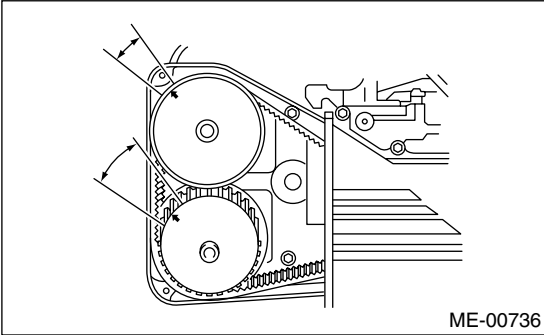

15) After inspection, install the related parts in the reverse order of removal.

Tightening torque:

33 N·m (3.4 kgf·m, 25 ft·lb)

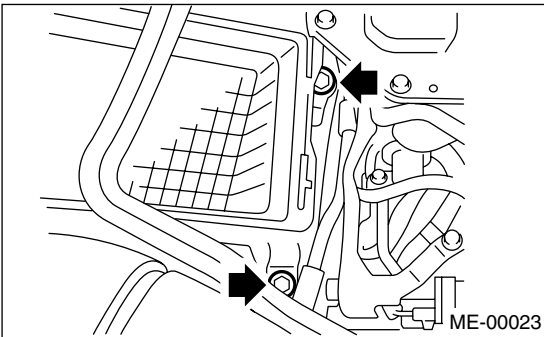

B: ADJUSTMENT

CAUTION:

Adjustment of the valve clearance should be performed while engine is cold.

1) Measure all valve clearances. <Ref. to ME(H4DOTC)-30, INSPECTION.>

NOTE:

Record each valve clearance after it has been measured.

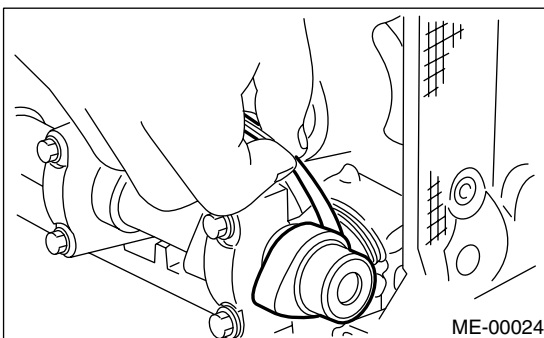

2) Remove the camshaft. <Ref. to ME(H4DOTC)-59, REMOVAL.>

3) Remove the valve lifter.

4) Measure the thickness of valve lifter with a micrometer.

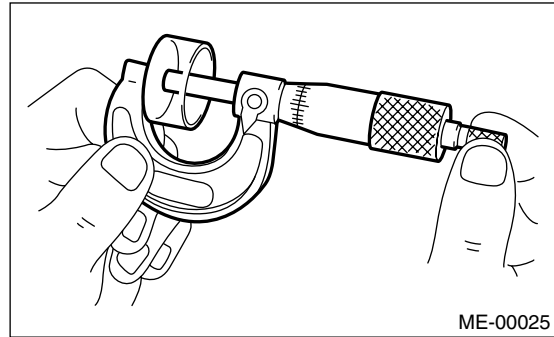

5) Select a valve lifter of suitable thickness using measured valve clearance and valve lifter thickness, by referring to the following table.

Unit: mm
Intake valve: $S = (V + T) - 0.20$
Exhaust valve: $S = (V + T) - 0.35$
S: Required thickness of valve lifter
V: Measured valve clearance
T: Used valve lifter thickness

VALVE CLEARANCE

MECHANICAL

Part No.	Thickness mm (in)
13228 AB101	4.68 (0.1843)
13228 AB111	4.69 (0.1846)
13228 AB121	4.70 (0.1850)
13228 AB131	4.71 (0.1854)
13228 AB141	4.72 (0.1858)
13228 AB151	4.73 (0.1862)
13228 AB161	4.74 (0.1866)
13228 AB171	4.75 (0.1870)
13228 AB181	4.76 (0.1874)
13228 AB191	4.77 (0.1878)
13228 AB201	4.78 (0.1882)
13228 AB211	4.79 (0.1886)
13228 AB221	4.80 (0.1890)
13228 AB231	4.81 (0.1894)
13228 AB241	4.82 (0.1898)
13228 AB251	4.83 (0.1902)
13228 AB261	4.84 (0.1906)
13228 AB271	4.85 (0.1909)
13228 AB281	4.86 (0.1913)
13228 AB291	4.87 (0.1917)
13228 AB301	4.88 (0.1921)
13228 AB311	4.89 (0.1925)
13228 AB321	4.90 (0.1929)
13228 AB331	4.91 (0.1933)
13228 AB341	4.92 (0.1937)
13228 AB351	4.93 (0.1941)
13228 AB361	4.94 (0.1945)
13228 AB371	4.95 (0.1949)
13228 AB381	4.96 (0.1953)
13228 AB391	4.97 (0.1957)
13228 AB401	4.98 (0.1961)
13228 AB411	4.99 (0.1965)
13228 AB421	5.00 (0.1969)
13228 AB431	5.01 (0.1972)
13228 AB441	5.02 (0.1976)
13228 AB451	5.03 (0.1980)
13228 AB461	5.04 (0.1984)
13228 AB471	5.05 (0.1988)
13228 AB481	5.06 (0.1992)
13228 AB491	5.07 (0.1996)
13228 AB501	5.08 (0.2000)
13228 AB511	5.09 (0.2004)
13228 AB521	5.10 (0.2008)
13228 AB531	5.11 (0.2012)
13228 AB541	5.12 (0.2016)
13228 AB551	5.13 (0.2020)
13228 AB561	5.14 (0.2024)
13228 AB571	5.15 (0.2028)
13228 AB581	5.16 (0.2031)
13228 AB591	5.17 (0.2035)
13228 AB601	5.18 (0.2039)

Part No.	Thickness mm (in)
13228 AB611	5.19 (0.2043)
13228 AB621	5.20 (0.2047)
13228 AB631	5.21 (0.2051)
13228 AB641	5.22 (0.2055)
13228 AB651	5.23 (0.2059)
13228 AB661	5.24 (0.2063)
13228 AB671	5.25 (0.2067)
13228 AB681	5.26 (0.2071)
13228 AB691	5.27 (0.2075)
13228 AB701	4.38 (0.1724)
13228 AB711	4.40 (0.1732)
13228 AB721	4.42 (0.1740)
13228 AB731	4.44 (0.1748)
13228 AB741	4.46 (0.1756)
13228 AB751	4.48 (0.1764)
13228 AB761	4.50 (0.1771)
13228 AB771	4.52 (0.1780)
13228 AB781	4.54 (0.1787)
13228 AB791	4.56 (0.1795)
13228 AB801	4.58 (0.1803)
13228 AB811	4.60 (0.1811)
13228 AB821	4.62 (0.1819)
13228 AB831	4.64 (0.1827)
13228 AB841	4.66 (0.1835)
13228 AB851	5.29 (0.2083)
13228 AB861	5.31 (0.2091)
13228 AB871	5.33 (0.2098)
13228 AB881	5.35 (0.2106)
13228 AB891	5.37 (0.2114)
13228 AB901	5.39 (0.2122)
13228 AB911	5.41 (0.2123)
13228 AB921	5.43 (0.2138)
13228 AB931	5.45 (0.2146)
13228 AB941	5.47 (0.2154)
13228 AB951	5.49 (0.2161)
13228 AB961	5.51 (0.2169)
13228 AB971	5.53 (0.2177)
13228 AB981	5.55 (0.2185)
13228 AB991	5.57 (0.2193)
13228 AC001	5.59 (0.2201)
13228 AC011	5.61 (0.2209)
13228 AC021	5.63 (0.2217)
13228 AC031	5.65 (0.2224)

6) Inspect all valves for clearance again at this stage. If the valve clearance is not correct, repeat the procedure over again from the first step.

7) After inspection, install the related parts in the reverse order of removal.

ENGINE ASSEMBLY

MECHANICAL

9. Engine Assembly

A: REMOVAL

- 1) Set the vehicle on a lift.
- 2) Open the front hood fully, and then support with the hood stay.
- 3) Collect the refrigerant from A/C system. <Ref. to AC-20, Refrigerant Recovery Procedure.>
- 4) Release the fuel pressure.
 - (1) Disconnect the fuel pump relay connector.

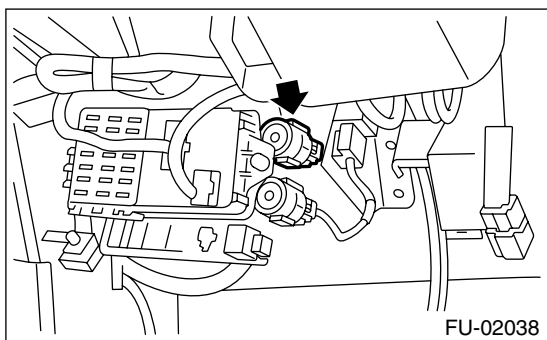

- (2) Start the engine, and run until stalls.
 - (3) After the engine stalls, crank it for 5 seconds more.
 - (4) Turn the ignition switch to OFF.
- 5) Remove the filler cap.
 - 6) Disconnect the ground cable from battery.

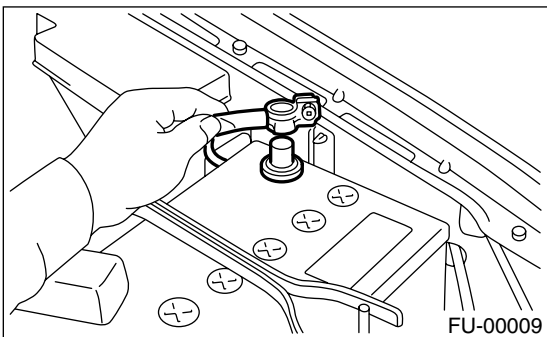

- 7) Remove the radiator from vehicle. <Ref. to CO(H4DOTC)-19, REMOVAL, Radiator.>
- 8) Remove the coolant filler tank. <Ref. to CO(H4DOTC)-29, REMOVAL, Coolant Filler Tank.>
- 9) Disconnect the A/C pressure hoses from A/C compressor.

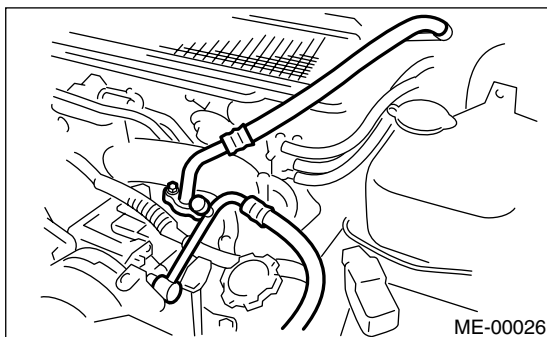

- 10) Remove the intercooler. <Ref. to IN(H4DOTC)-10, REMOVAL, Intercooler.>
- 11) Disconnect the following connectors and cable.
 - (1) Engine harness connector

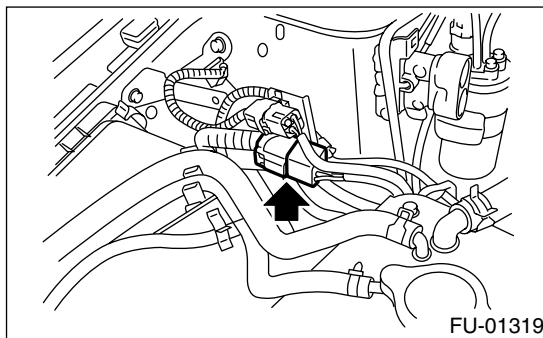

- (2) Engine ground terminal

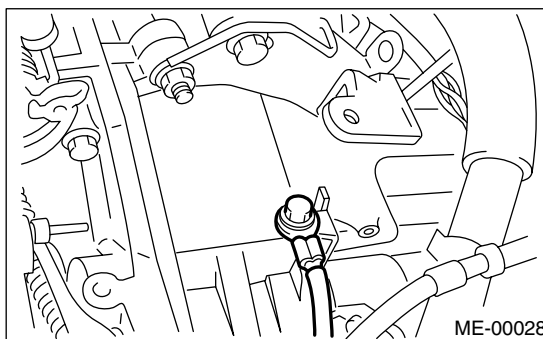

- (3) Disconnect engine ground cables on the left and right sides.

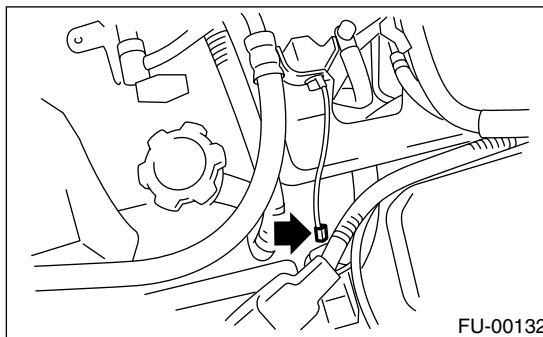
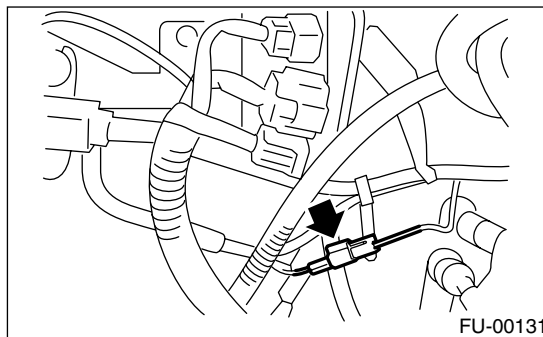

(4) Engine harness connector

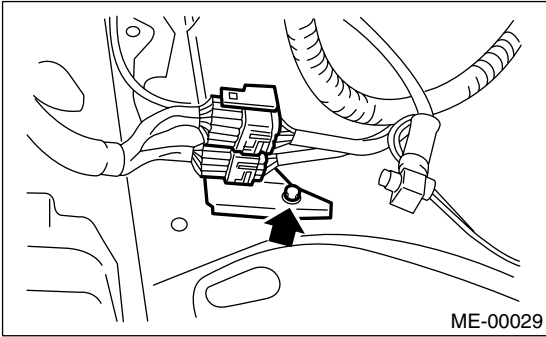

(2) Heater inlet outlet hose

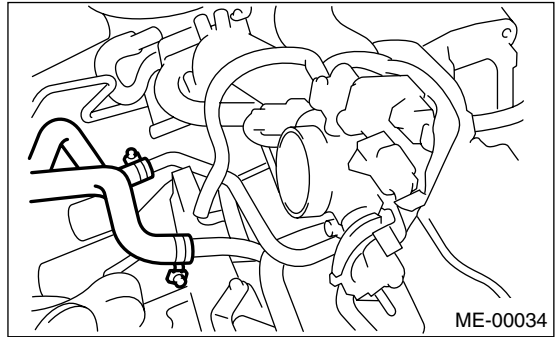

(5) Generator connector, terminal and A/C compressor connectors

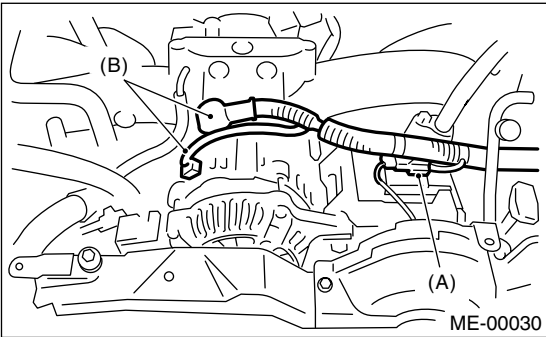

- (A) A/C compressor connector
- (B) Generator connector and terminal

(6) Clutch release spring (MT model)

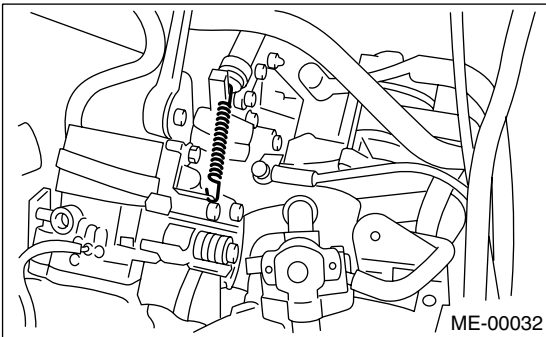

12) Disconnect the following hoses.

(1) Brake booster vacuum hose

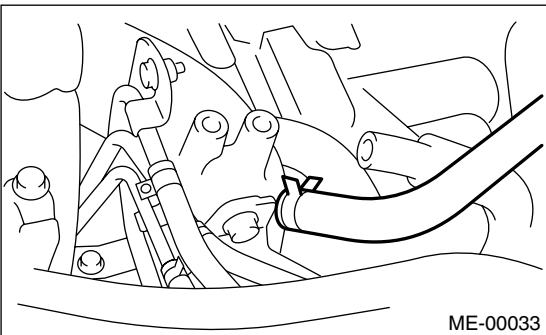

13) Remove the power steering pump from bracket.

- (1) Loosen the lock bolt and slider bolt, and then remove the front side V-belt. <Ref. to ME(H4DOTC)-45, FRONT SIDE BELT, REMOVAL, V-belt.>
- (2) Disconnect the power steering switch connector.

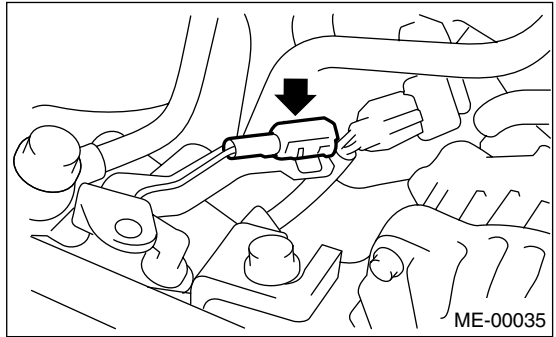

(3) Remove the pipe with bracket from intake manifold.

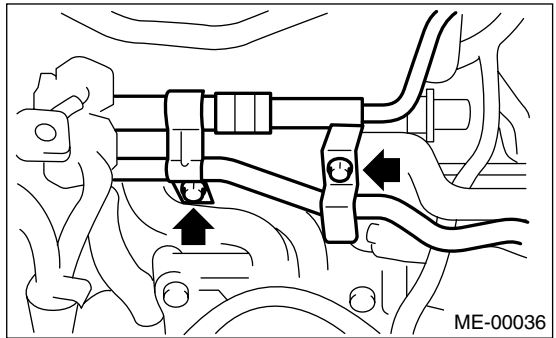

ENGINE ASSEMBLY

MECHANICAL

(4) Remove the power steering pump from engine.

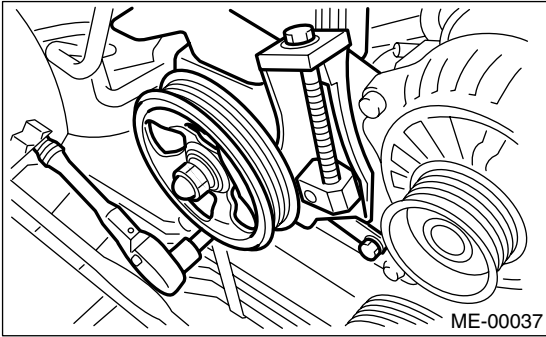

(5) Remove the power steering tank from bracket by pulling it upward.

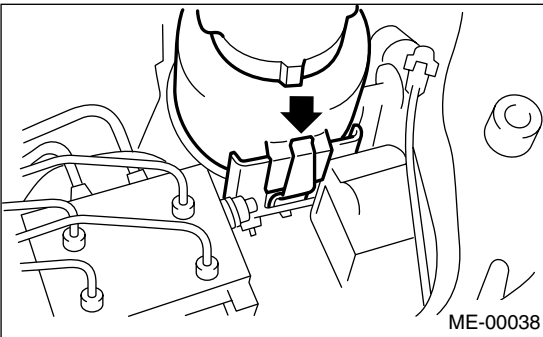

(6) Place the power steering pump on right side wheel apron.

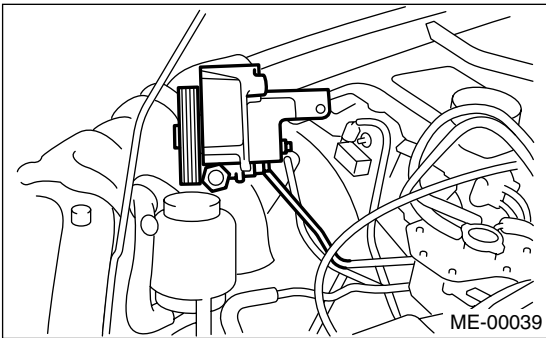

14) Lift-up the vehicle.

15) Remove ATF cooler pipe from frame. (AT model)

16) Remove the center exhaust pipe.<Ref. to EX(H4DOTC)-9, REMOVAL, Center Exhaust Pipe.>

17) Remove the nuts which hold the lower side of transmission to engine.

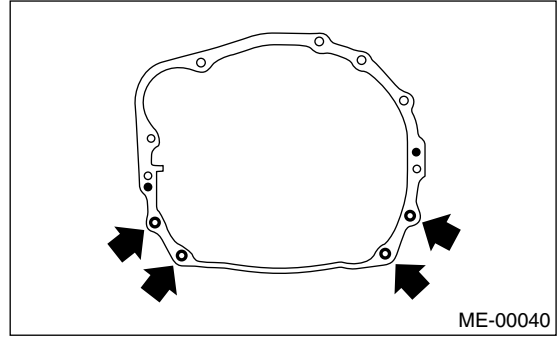

18) Remove the nuts which install the front cushion rubber onto front crossmember.

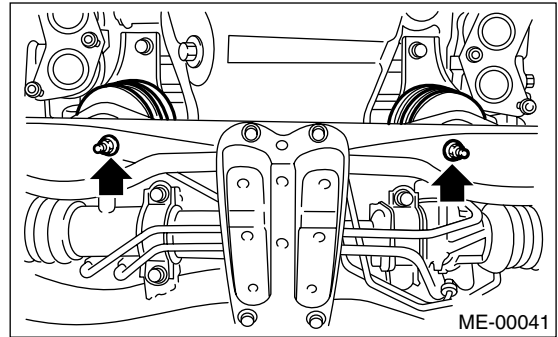

19) Lower the vehicle.

20) Separate the clutch release fork from release bearing. (MT model)

(1) Remove the clutch operating cylinder from transmission.

(2) Remove the plug using a 10 mm hexagon wrench.

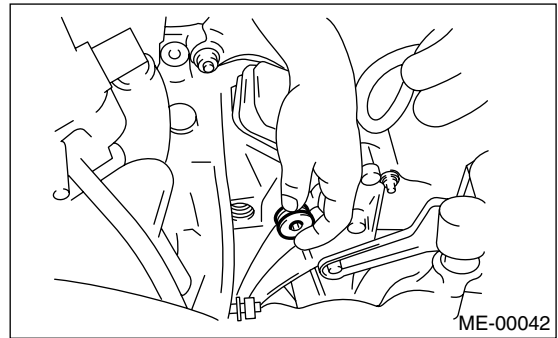

(3) Screw the 6 mm dia. bolt into release fork shaft, and remove it.

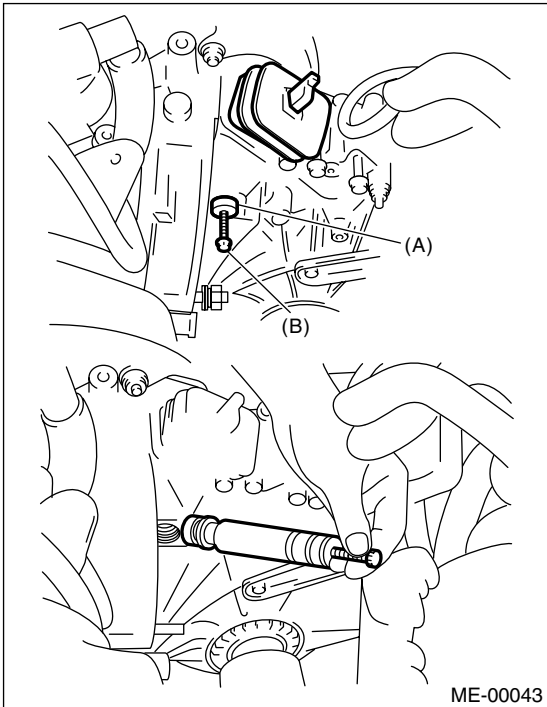

- (A) Shaft
- (B) Bolt

(4) Raise the release fork, and then unfasten the release bearing tabs to free release fork.

NOTE:

Step (4) is required to prevent interference with engine when removing the engine from transmission.

21) Separate torque converter clutch from drive plate. (AT model)

- (1) Lower the vehicle.
- (2) Remove service hole plug.
- (3) Remove bolts which hold torque converter clutch to drive plate.
- (4) Remove other bolts while rotating the engine using socket wrench.

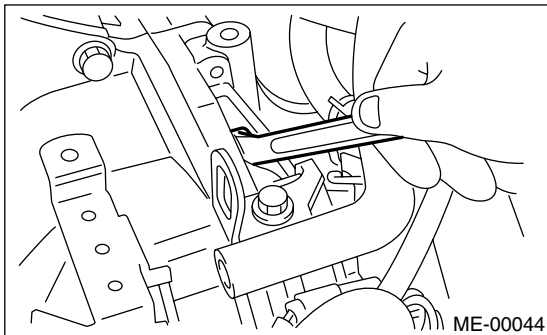

22) Remove the pitching stopper.

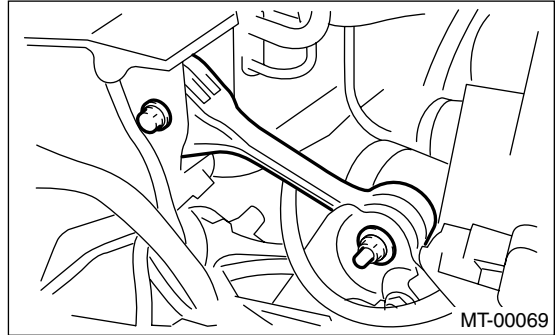

23) Disconnect the fuel delivery hose, return hose and evaporation hose.

NOTE:

- Catch fuel from the hose into container.
- Disconnect the hose with its end wrapped with cloth to prevent fuel from splashing.

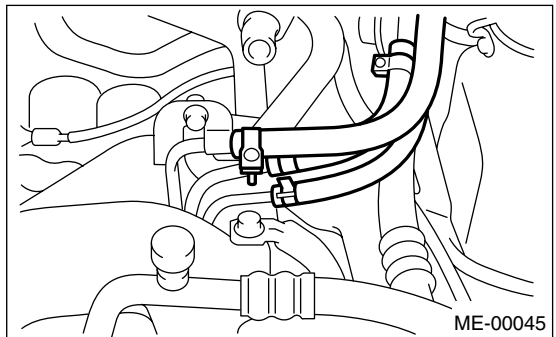

24) Remove fuel filter and bracket.

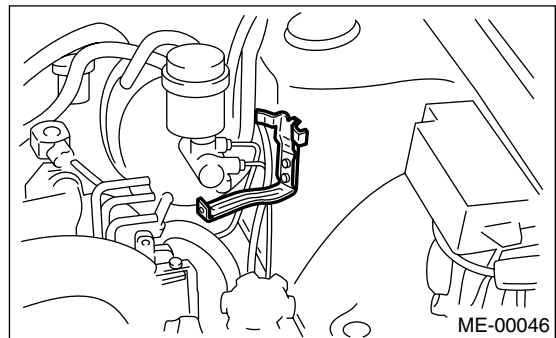

25) Support the engine with a lifting device and wire ropes.

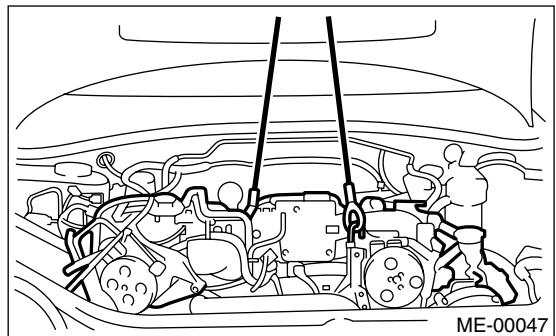

ENGINE ASSEMBLY

MECHANICAL

26) Support the transmission with a garage jack.

NOTE:

Before moving the engine away from transmission, check to be sure no work has been overlooked. Doing this is very important in order to facilitate re-installation and because transmission lowers under its own weight.

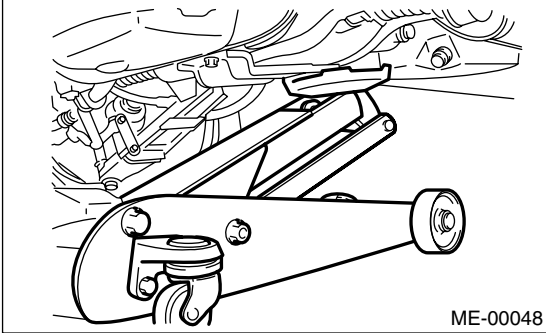

27) Separation of the engine and transmission.

(1) Remove the starter. <Ref. to SC(H4SO)-7, REMOVAL, Starter.>

(2) Install special tool to torque converter clutch case. (AT model)

ST 498277200 STOPPER SET

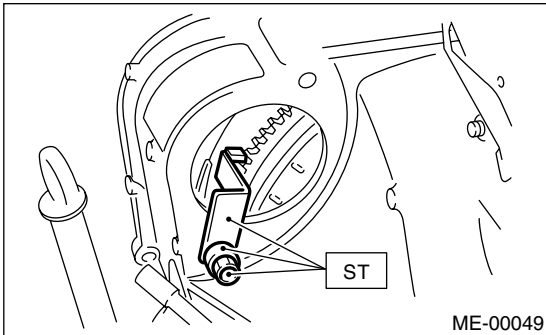

(3) Remove the bolts which hold the right upper side of transmission to engine.

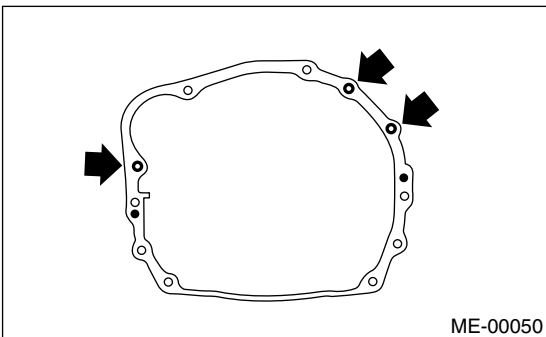

28) Remove the engine from vehicle.

(1) Slightly raise the engine.

(2) Raise the transmission with garage jack.

(3) Move the engine horizontally until the main shaft is withdrawn from clutch cover.

(4) Slowly move the engine away from engine compartment.

NOTE:

Be careful not to damage adjacent parts or body panels with crank pulley, oil pressure gauge, etc.

29) Remove the front cushion rubbers.

B: INSTALLATION

1) Install the clutch release fork and bearing onto transmission.

(1) Remove the release bearing from clutch cover with flat type screw driver.

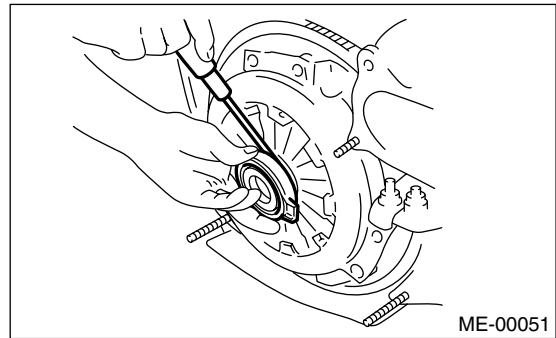

(2) Install the release bearing on transmission.

(3) Install the release fork into release bearing tab.

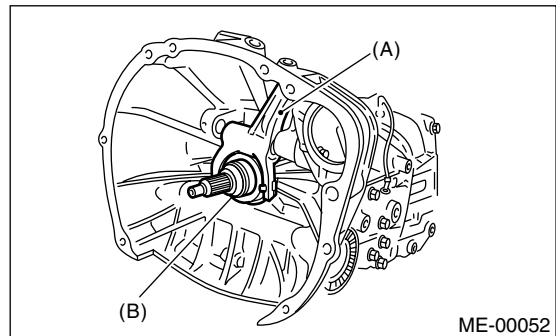

(A) Release fork

(B) Release bearing

(4) Apply grease to the specified points.

- Spline FX2200

• Shaft SUNLIGHT 2

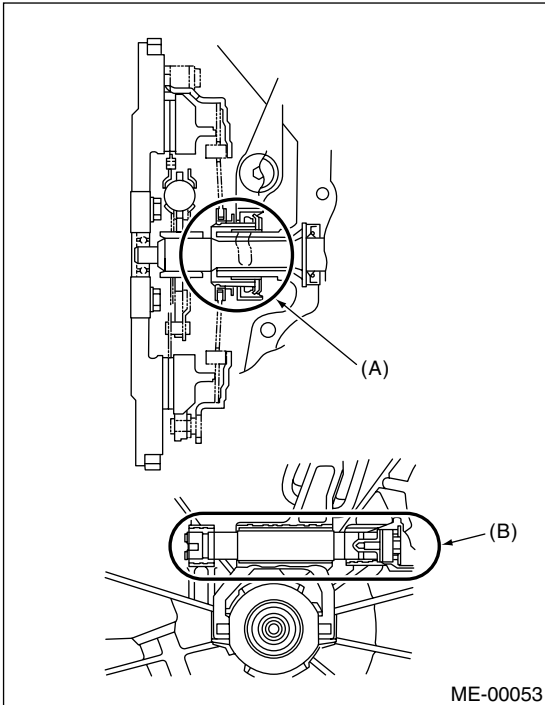

- (A) Spline (FX2200)
- (B) Shaft (SUNLIGHT 2)

(5) Insert the release fork shaft into release fork.

CAUTION:
Make sure the cutout portion of release fork shaft contacts spring pin.

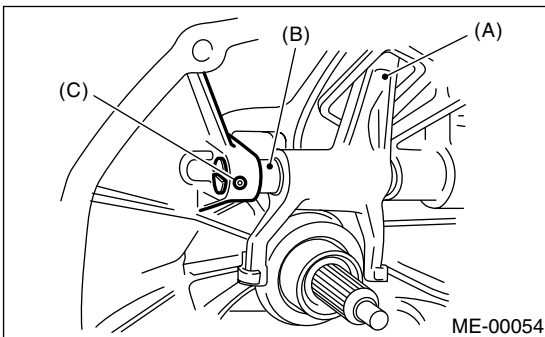

- (A) Release fork
- (B) Release shaft
- (C) Spring pin

(6) Tighten the plug.

Tightening torque:
44 N·m (4.5 kgf·m, 32.5 ft·lb)

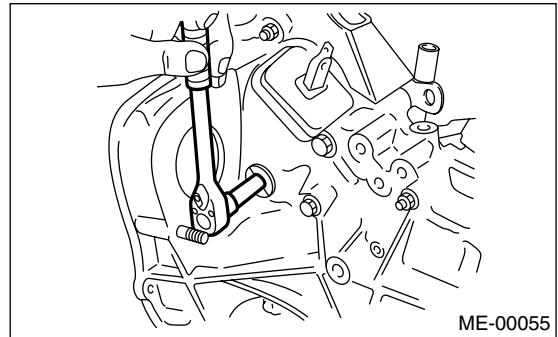

2) Install the front cushion rubbers to engine.

Tightening torque:
34 N·m (3.5 kgf·m, 25.3 ft·lb)

3) Install the engine onto transmission.
(1) Position the engine in engine compartment, and then align it with the transmission.

NOTE:

Be careful not to damage the adjacent parts or body panels with crank pulley, oil pressure gauge, etc.

(2) Apply a small amount of grease to the splines of mainshaft. (MT model)

4) Tighten the bolts which hold the right upper side of transmission to engine.

Tightening torque:
50 N·m (5.1 kgf·m, 36.9 ft·lb)

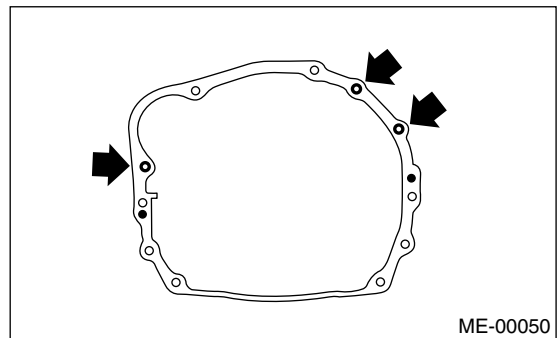

5) Remove the lifting device and wire ropes.
6) Remove the garage jack.

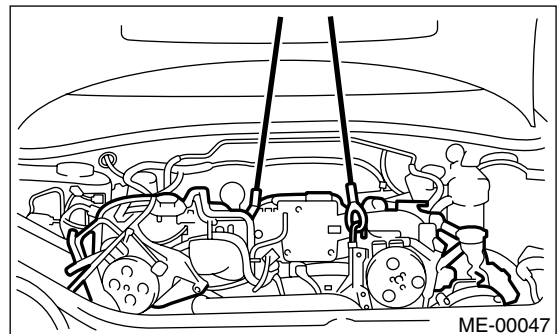

ENGINE ASSEMBLY

MECHANICAL

7) Install the pitching stopper.

Tightening torque:

T1: 50 N·m (5.1 kgf-m, 37 ft-lb)

T2: 58 N·m (5.9 kgf-m, 43 ft-lb)

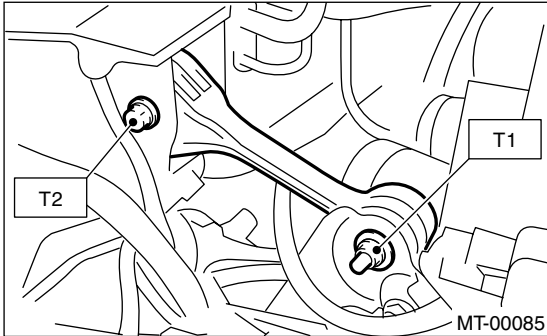

8) Remove special tool from torque converter clutch case. (AT model)

NOTE:

Be careful not to drop the special tool into the torque converter clutch case when installing it.

ST 498277200 STOPPER SET

9) Install starter. <Ref. to SC(H4SO)-7, Starter.>

10) Install torque converter clutch to drive plate. (AT model)

(1) Tighten bolts which hold torque converter clutch to drive plate.

(2) Tighten other bolts while rotating the engine by using socket wrench.

CAUTION:

Be careful not to drop bolts into torque converter clutch housing.

Tightening torque:

25 N·m (2.5 kgf-m, 18.1 ft-lb)

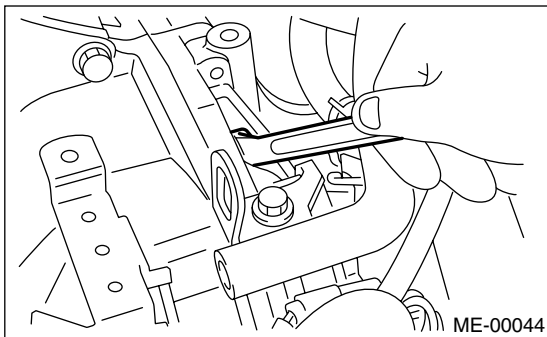

(3) Clog plug onto service hole.

11) Install fuel filter and bracket.

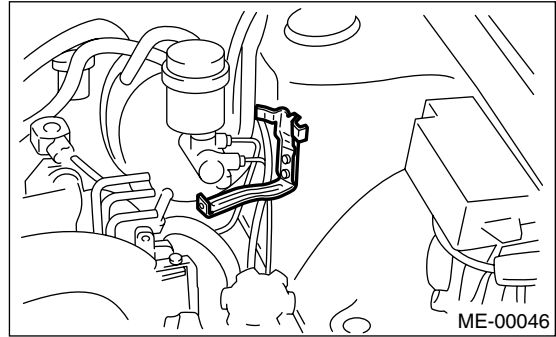

12) Install the power steering pump on bracket.

(1) Install the power steering tank on bracket.

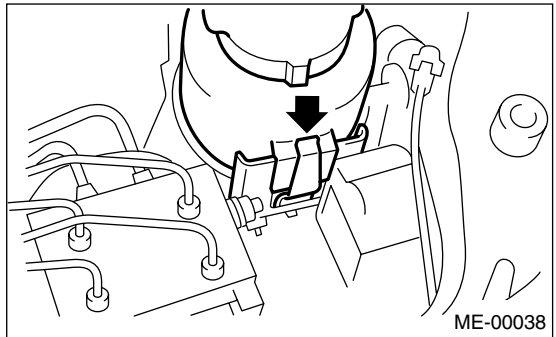

(2) Install the power steering pump.

Tightening torque:
20.1 N·m (2.05 kgf·m, 14.8 ft·lb)

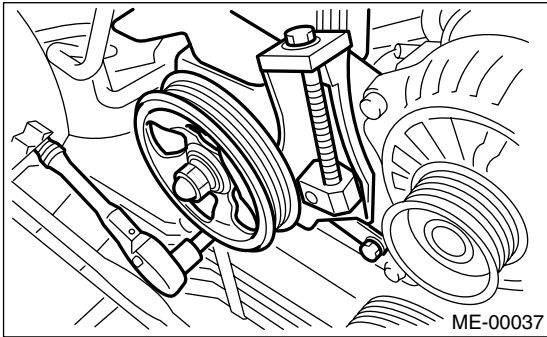

(3) Install the power steering pipe bracket on intake manifold RH.

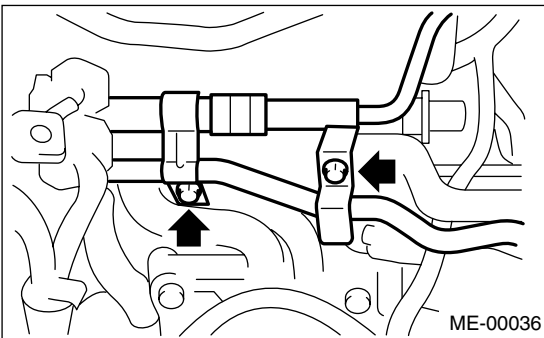

(4) Connect the power steering switch connector.

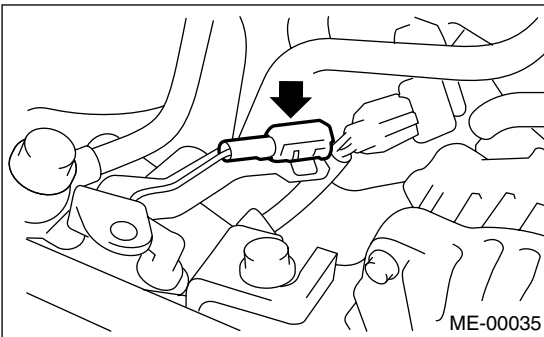

(5) Install the front side V-belt, and adjust it.
 <Ref. to ME(H4DOTC)-45, REAR SIDE BELT, INSTALLATION, V-belt.>

13) Lift-up the vehicle.

14) Tighten the nuts which hold the lower side of transmission to engine.

Tightening torque:
50 N·m (5.1 kgf·m, 36.9 ft·lb)

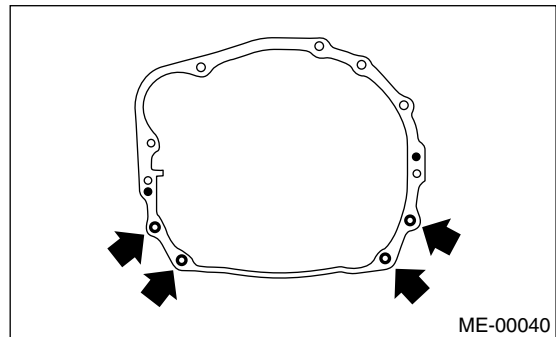

15) Tighten the nuts which install the front cushion rubber onto crossmember.

Tightening torque:
83 N·m (8.5 kgf·m, 61 ft·lb)

NOTE:

Make sure the front cushion rubber mounting bolts (A) and locator (B) are securely installed.

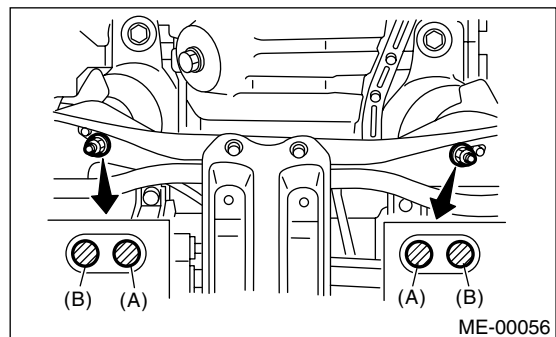

16) Install ATF cooler pipe to frame. (AT model)

17) Install the center exhaust pipe. <Ref. to EX(H4DOTC)-10, INSTALLATION, Center Exhaust Pipe.>

18) Lower the vehicle.

19) Connect the following hoses:

- (1) Fuel delivery hose, return hose and evaporation hose
- (2) Heater inlet and outlet hoses
- (3) Brake booster vacuum hose

20) Connect the following connectors and terminals:

- (1) Engine ground terminal
- (2) Engine harness connectors
- (3) Generator connector and terminal
- (4) A/C compressor connectors

21) Connect the following cables:

- (1) Accelerator cable
- (2) Clutch release spring

22) After connecting each cable, adjust them.

23) Install the air intake system.

- (1) Install the intercooler. <Ref. to IN(H4DOTC)-11, INSTALLATION, Intercooler.>

ENGINE ASSEMBLY

MECHANICAL

- (2) Install the air cleaner element and air cleaner upper cover.
 - (3) Install the engine harness connector bracket.
 - (4) Install the filler hose to air cleaner case.
- 24) Install the A/C pressure hoses.

NOTE:

Use new O-rings.

Tightening torque:

25 N·m (2.5 kgf-m, 18.1 ft-lb)

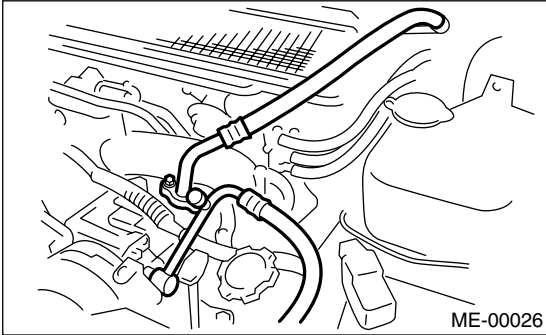

- 25) Install the radiator. <Ref. to CO(H4DOTC)-20, INSTALLATION, Radiator.>
- 26) Install the coolant filler tank. <Ref. to CO(H4DOTC)-29, INSTALLATION, Coolant Filler Tank.>
- 27) Install the window washer tank.
- 28) Install the battery in the vehicle, and then connect the cables.
- 29) Fill coolant.
<Ref. to CO(H4DOTC)-13, FILLING OF ENGINE COOLANT, REPLACEMENT, Engine Coolant.>
- 30) Charge the A/C system with refrigerant.
<Ref. to AC-21, Refrigerant Charging Procedure.>
- 31) Remove the front hood stay, and close the front hood.
- 32) Take off the vehicle from lift arms.

10.Engine Mounting

A: REMOVAL

- 1) Remove the engine assembly. <Ref. to ME(H4DOTC)-34, REMOVAL, Engine Assembly.>
- 2) Remove the engine mounting from engine assembly.

B: INSTALLATION

Install in the reverse order of removal.

Tightening torque:

Engine mounting;

35 N·m (3.6 kgf-m, 25.8 ft-lb)

C: INSPECTION

Make sure there are no cracks or other damage.

PREPARATION FOR OVERHAUL

MECHANICAL

11. Preparation for Overhaul

A: PROCEDURE

1) After removing the engine from body, secure it in the ST shown below.

ST1	498457000	ENGINE STAND ADAPTER RH
ST2	498457100	ENGINE STAND ADAPTER LH
ST3	4998170 00	ENGINE STAND

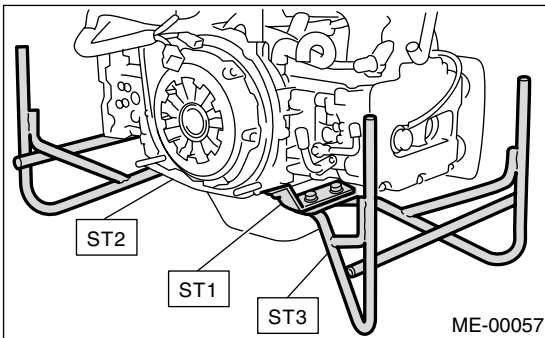

2) In this section the procedures described under each index are all connected and stated in order. It will be the complete procedure for overhauling of the engine itself when you go through all steps in the process.

Therefore, in this section, to conduct the particular procedure within the flow of a section, you need to go back and conduct the procedure described previously in order to do that particular procedure.

12.V-belt

A: REMOVAL

1. FRONT SIDE BELT

- 1) Remove the V-belt cover.

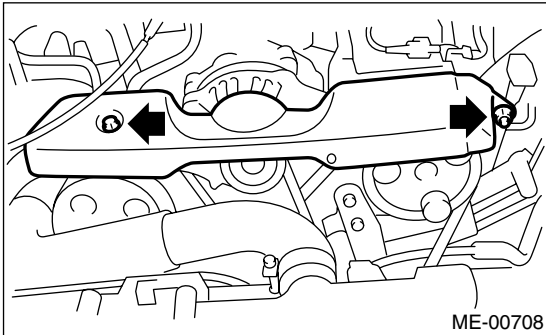

- 2) Loosen the lock bolt (A).
- 3) Loosen the slider bolt (B).
- 4) Remove the front side belt (C).

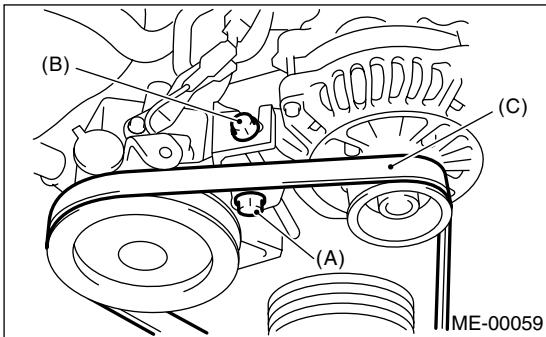

2. REAR SIDE BELT

- 1) Loosen the lock nut (A).
- 2) Loosen the slider bolt (B).

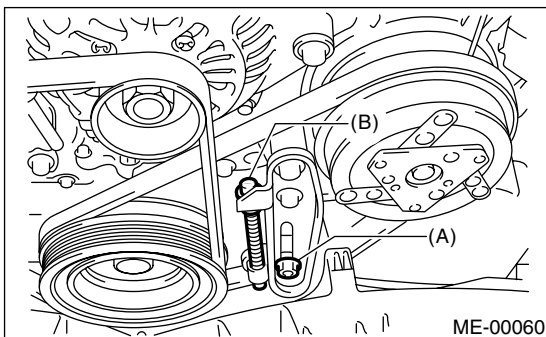

- 3) Remove the A/C belt.

- 4) Remove the A/C belt tensioner.

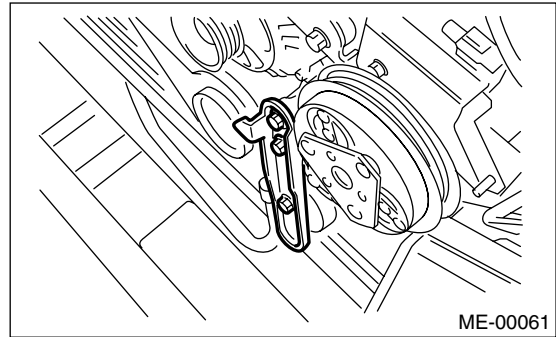

B: INSTALLATION

1. FRONT SIDE BELT

CAUTION:

Wipe off any oil or water on the belt and pulley.

- 1) Install the belt (C), and tighten the slider bolt so as to obtain the specified belt tension <Ref. to ME(H4DOTC)-46, INSPECTION.>
- 2) Tighten the lock bolt (A).
- 3) Tighten the slider bolt (B).

Tightening torque:

Lock bolt through bolt:

25 N·m (2.5 kgf·m, 18.1 ft·lb)

Slider bolt:

8 N·m (0.8 kgf·m, 5.5 ft·lb)

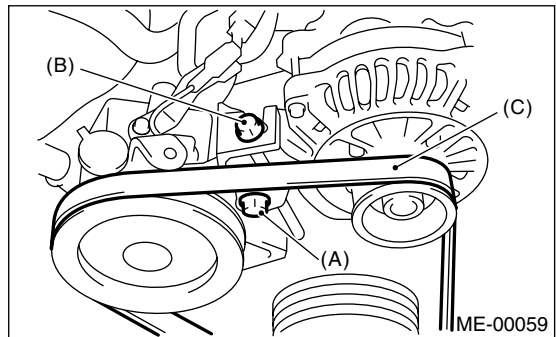

2. REAR SIDE BELT

- 1) Install the belt, and tighten the slider bolt (B) so as to obtain the specified belt tension. <Ref. to ME(H4DOTC)-46, INSPECTION.>

V-BELT

MECHANICAL

2) Tighten the lock nut (A).

Tightening torque:

Lock nut (A);
22.6 N·m (2.3 kgf-m, 16.6 ft-lb)

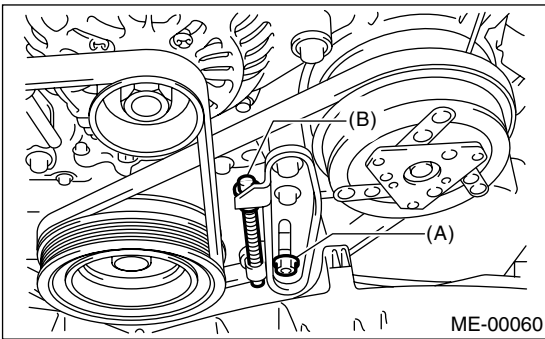

C: INSPECTION

- 1) Replace the belts, if cracks, fraying or wear is found.
- 2) Check the drive belt tension and adjust it if necessary by changing generator installing position and/or idler pulley installing position.

Belt tension (With using belt tension gauge)

(A)

replaced: 618 — 755 N (63 — 77 kgf, 139 — 170 lb)

reused: 490 — 640 N (50 — 65 kgf, 110 — 144 lb)

(B)*

replaced: 740 — 880 N (75 — 90 kgf, 166 — 198 lb)

reused: 350 — 450 N (36 — 46 kgf, 78 — 101 lb)

***: with air conditioner**

Belt tension

(A)

replaced: 7 — 9 mm (0.276 — 0.354 in)

reused: 9 — 11 mm (0.354 — 0.433 in)

(B)*

replaced: 7.5 — 8.5 mm (0.295 — 0.335 in)

reused: 9.0 — 10.0 mm (0.354 — 0.394 in)

***: with air conditioner**

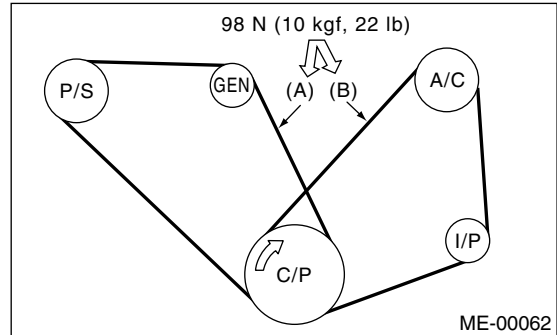

C/P Crankshaft pulley

GEN Generator

P/S Power steering oil pump pulley

A/C Air conditioning compressor pulley

I/P Idler pulley

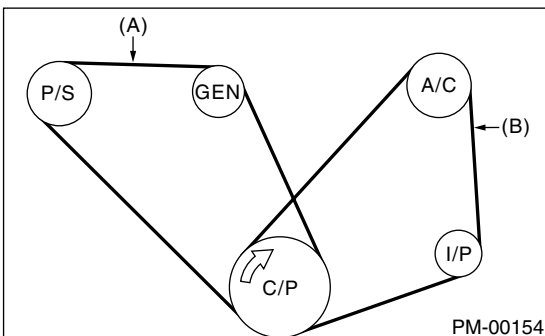

(A) Front side belt

(B) Rear side belt

C/P Crankshaft pulley

GEN Generator

P/S Power steering oil pump pulley

A/C A/C compressor pulley

I/P Idler pulley

13.Crankshaft Pulley

A: REMOVAL

1) Remove the V-belt. <Ref. to ME(H4DOTC)-45, REMOVAL, V-belt.>

2) Remove the crankshaft pulley bolt. To lock the crankshaft, use ST.

ST 499977100 CRANKSHAFT PULLEY WRENCH

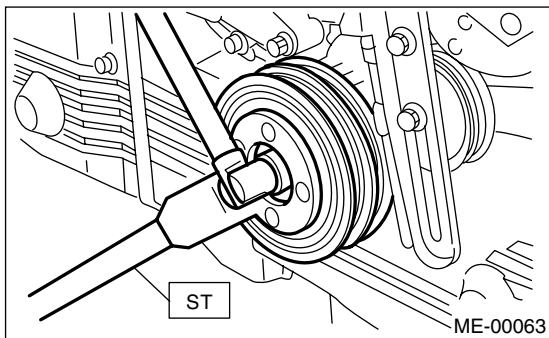

3) Remove the crankshaft pulley.

B: INSTALLATION

1) Install the crankshaft pulley.

2) Install the pulley bolt.

To lock the crankshaft, use ST.

ST 499977100 CRANKSHAFT PULLEY WRENCH

(1) Clean the crankshaft pulley thread using an air gun.

(2) Apply engine oil to the crankshaft pulley bolt seat and thread.

(3) Tighten the bolts temporarily with tightening torque of 44 N·m (4.5 kgf-m, 33 ft-lb).

(4) Tighten the crankshaft pulley bolts.

Tightening torque:

180 N·m (18.3 kgf-m, 132.7 ft-lb)

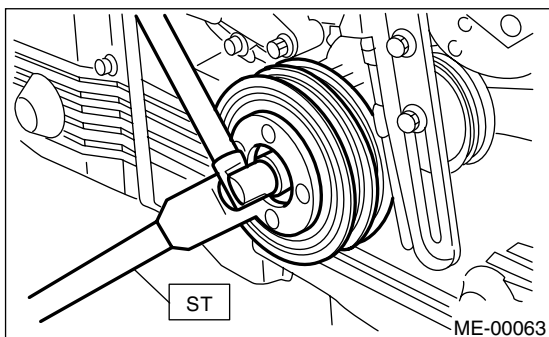

3) Confirm that the tightening angle of crankshaft pulley bolt is 65 degrees or more. If the tightening angle of crankshaft pulley bolt is less than 65 degrees, conduct the following procedures.

CAUTION:

If the tightening angle of crankshaft pulley bolt is less than 65 degrees, the bolt should be damaged. In this case, the bolt must be replaced.

(1) Replace the crankshaft pulley bolts and clean them.

Crankshaft pulley bolt:

12369AA011

(2) Clean the crankshaft thread using an air gun.

(3) Apply engine oil to the crankshaft pulley bolt seat and thread.

(4) Tighten the bolts temporarily with tightening torque of 44 N·m (4.5 kgf-m, 33 ft-lb).

(5) Tighten the crankshaft pulley bolts keeping them in an angle between 65 degrees and 75 degrees.

NOTE:

Conduct the tightening procedures by confirming the turning angle of crankshaft pulley bolt referring to the gauge indicated on timing belt cover.

4) Install the A/C belt tensioner.

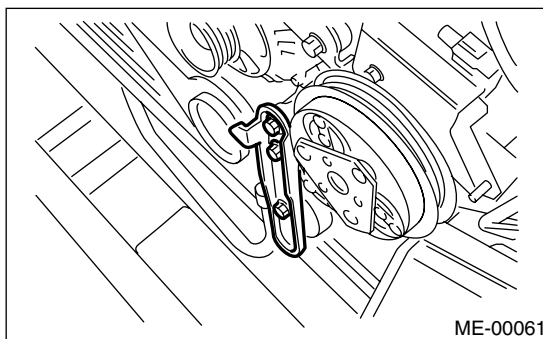

5) Install the V-belt. <Ref. to ME(H4DOTC)-45, INSTALLATION, V-belt.>

C: INSPECTION

1) Make sure the V-belt is not worn or otherwise damaged.

2) Check the tension of the belt. <Ref. to ME(H4DOTC)-46, INSPECTION, V-belt.>

14. Timing Belt Cover

A: REMOVAL

- 1) Remove the V-belt. <Ref. to ME(H4DOTC)-45, REMOVAL, V-belt.>
- 2) Remove the crankshaft pulley. <Ref. to ME(H4DOTC)-47, REMOVAL, Crankshaft Pulley.>
- 3) Remove the timing belt cover (LH) (A).
- 4) Remove the timing belt cover (RH) (B).
- 5) Remove the front timing belt cover (C).

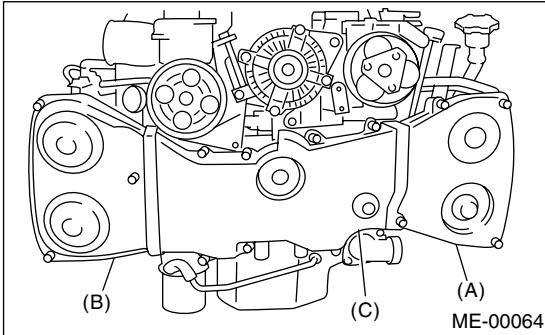

B: INSTALLATION

- 1) Install the front timing belt cover (C).

Tightening torque:

5 N·m (0.5 kgf-m, 3.6 ft-lb)

- 2) Install the timing belt cover (RH) (B).

Tightening torque:

5 N·m (0.5 kgf-m, 3.6 ft-lb)

- 3) Install the timing belt cover (LH) (A).

Tightening torque:

5 N·m (0.5 kgf-m, 3.6 ft-lb)

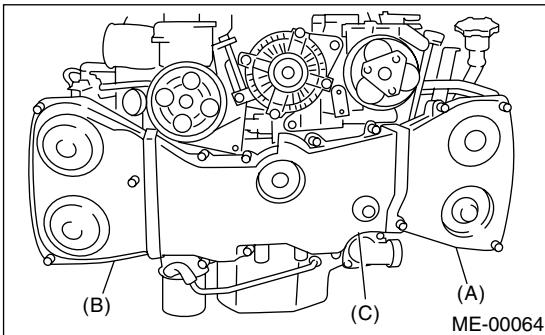

- 4) Install the crankshaft pulley. <Ref. to ME(H4DOTC)-47, **INSTALLATION, CRANKSHAFT PULLEY.**>
- 5) Install the V-belt. <Ref. to ME(H4DOTC)-45, INSTALLATION, V-belt.>

C: INSPECTION

Make sure the cover is not damaged.

15. Timing Belt Assembly

A: REMOVAL

1. TIMING BELT

1) Remove the V-belt. <Ref. to ME(H4DOTC)-45, REMOVAL, V-belt.>

2) Remove the crankshaft pulley. <Ref. to ME(H4DOTC)-47, REMOVAL, Crankshaft Pulley.>

3) Remove the timing belt cover. <Ref. to ME(H4DOTC)-48, REMOVAL, Timing Belt Cover.>

4) Remove the timing belt guides. (MT model)

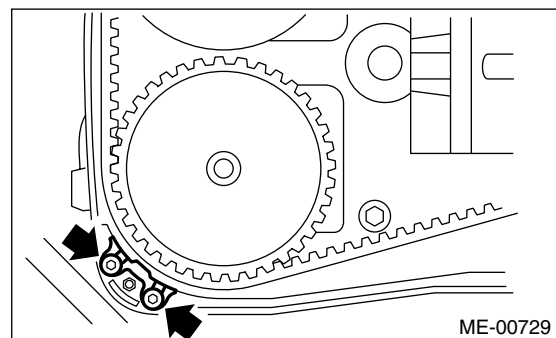
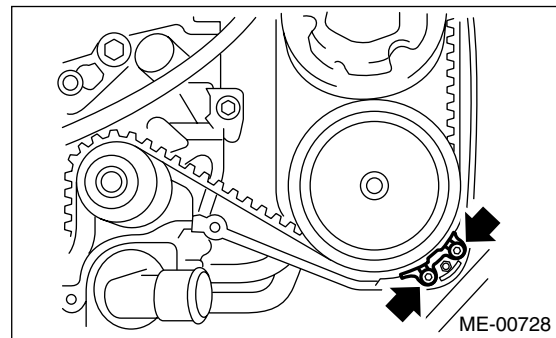
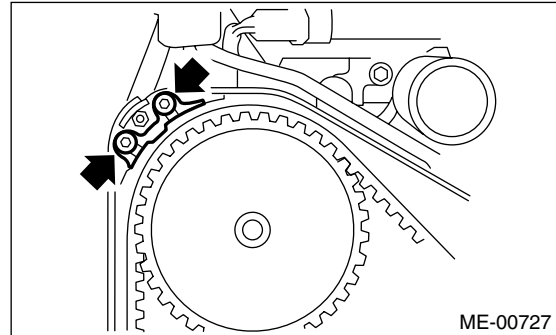
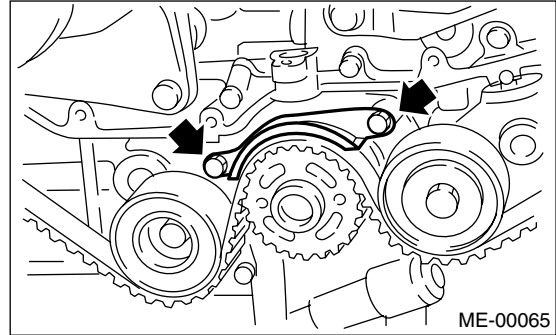

5) If the alignment mark and/or arrow mark (which indicates rotation direction) on timing belt fade away, put new marks before removing the timing belt as follows:

(1) Turn the crankshaft using ST, and align the alignment marks on crankshaft sprocket, intake camshaft sprocket (LH), exhaust camshaft sprocket (LH), intake camshaft sprocket (RH) and exhaust camshaft sprocket (RH) with notches of timing belt cover and cylinder block.

TIMING BELT ASSEMBLY

MECHANICAL

ST 499987500 CRANKSHAFT SOCKET

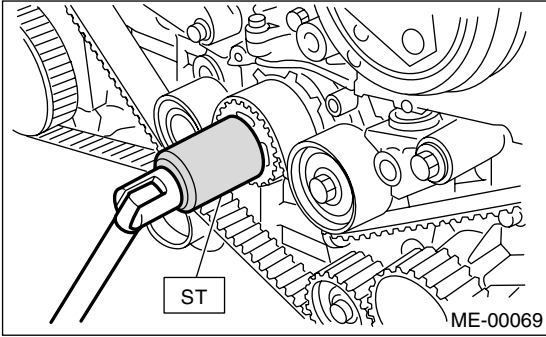

(2) Using white paint, put alignment and/or arrow marks on the timing belts in relation to the sprockets.

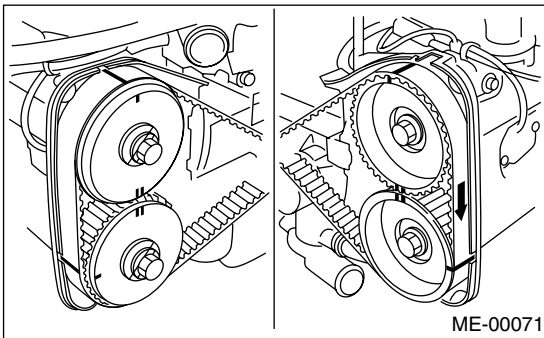
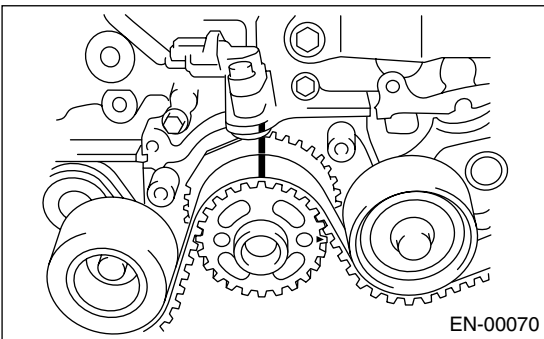

Z₁: 54.5 tooth length
Z₂: 51 tooth length
Z₃: 28 tooth length

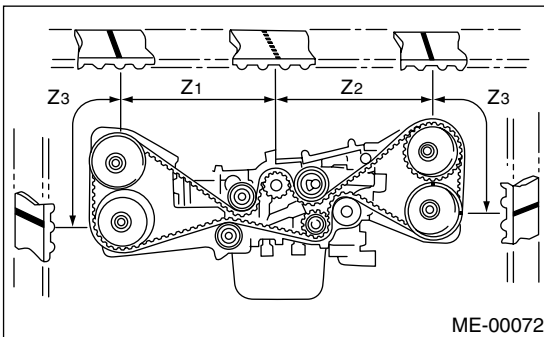

6) Remove the belt idler (A).

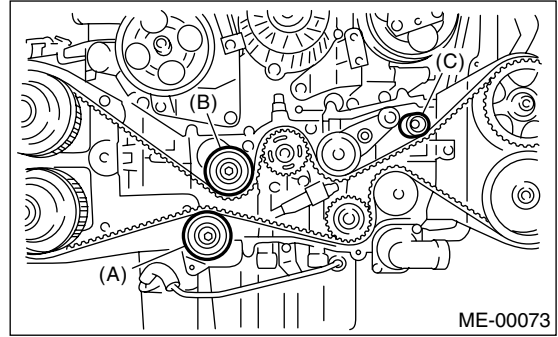

7) Remove the timing belt.

CAUTION:

After the timing belt has been removed, never rotate the intake and exhaust, camshaft sprocket. If the camshaft sprocket is rotated, the intake and exhaust valve heads strike together and valve stems are bent.

2. BELT IDLER AND AUTOMATIC BELT TENSION ADJUSTER ASSEMBLY

1) Remove the belt idler (B) and (C).

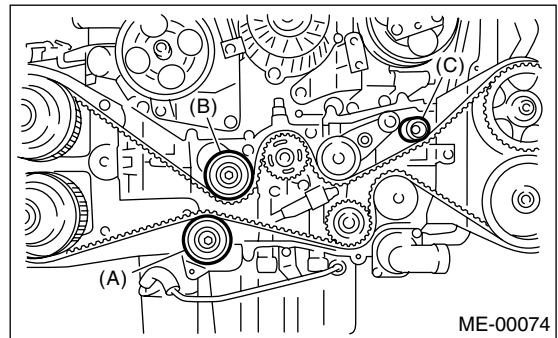

2) Remove the belt idler No. 2.

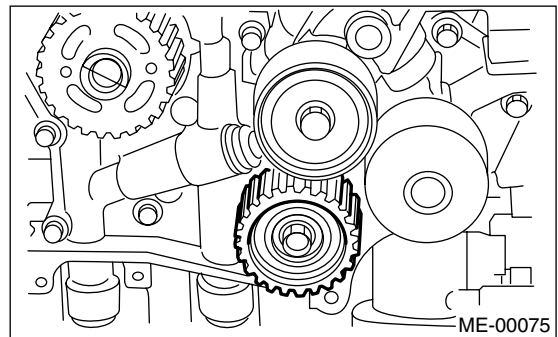

3) Remove the automatic belt tension adjuster assembly.

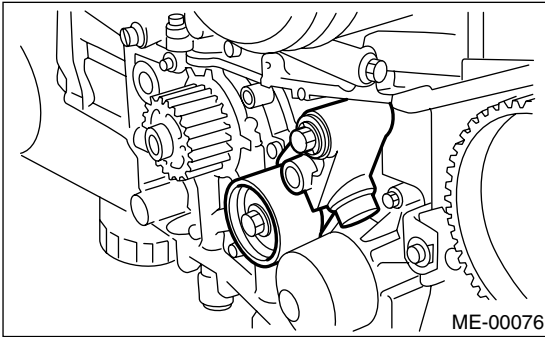

B: INSTALLATION

1. AUTOMATIC BELT TENSION ADJUSTER ASSEMBLY AND BELT IDLER

1) Preparation for installation of automatic belt tension adjuster assembly:

NOTE:

- Always use a vertical type pressing tool to move the adjuster rod down.
- Do not use a lateral type vise.
- Push the adjuster rod vertically.
- Be sure to slowly move the adjuster rod down applying a pressure of 294 N (30 kgf, 66 lb).
- Press-in the push adjuster rod gradually taking more than 3 minutes.
- Do not allow press pressure to exceed 9,807 N (1,000 kgf, 2,205 lb).
- Press the adjuster rod as far as the end surface of cylinder. Do not press the adjuster rod into the cylinder. Doing so may damage the cylinder.
- Do not release the press pressure until stopper pin is completely inserted.

(1) Attach the automatic belt tension adjuster assembly to the vertical pressing tool.

(2) Slowly move the adjuster rod down with a pressure of 294 N (30 kgf, 66 lb) until the adjuster rod is aligned with the stopper pin hole in the cylinder.

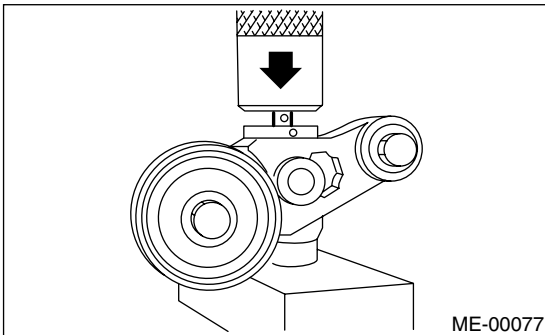

(3) With a 2 mm (0.08 in) dia. stopper pin or a 2 mm (0.08 in) (nominal) dia. hex bar wrench inserted into the stopper pin hole in the cylinder, secure the adjuster rod.

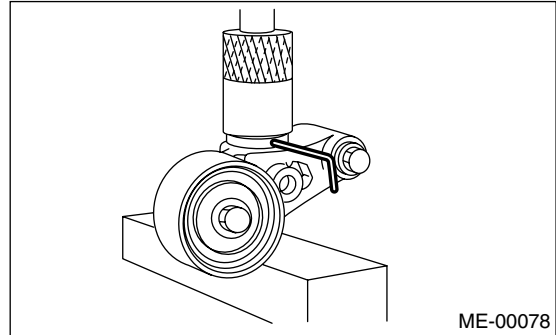

2) Install the automatic belt tension adjuster assembly.

Tightening torque:

39 N·m (4.0 kgf·m, 28.9 ft·lb)

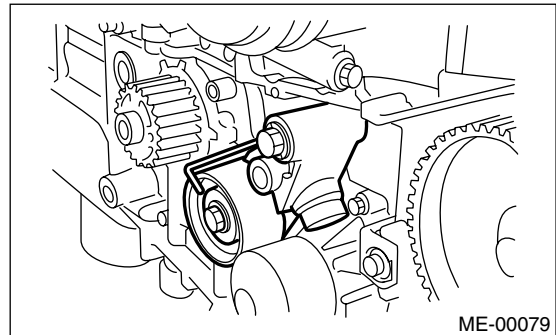

3) Install the belt idler No. 2.

Tightening torque:

39 N·m (4.0 kgf·m, 28.9 ft·lb)

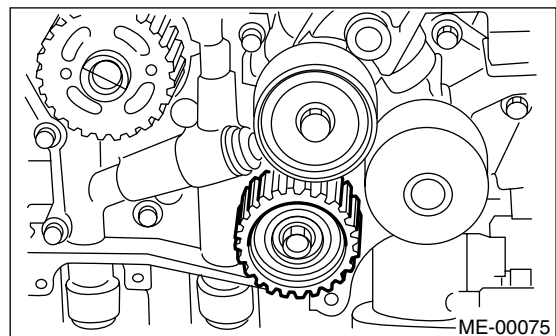

TIMING BELT ASSEMBLY

MECHANICAL

4) Install the belt idler.

Tightening torque:

39 N·m (4.0 kgf·m, 28.9 ft·lb)

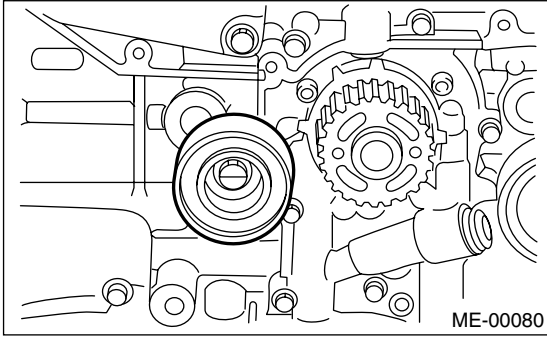

2. TIMING BELT

1) Preparation for installation of automatic belt tension adjuster assembly. <Ref. to ME(H4DOTC)-56, AUTOMATIC BELT TENSION ADJUSTER, INSPECTION, Timing Belt Assembly.>

2) Crankshaft and camshaft sprocket alignment.

(1) Align mark (A) on the crankshaft sprocket with mark on the oil pump cover at cylinder block.

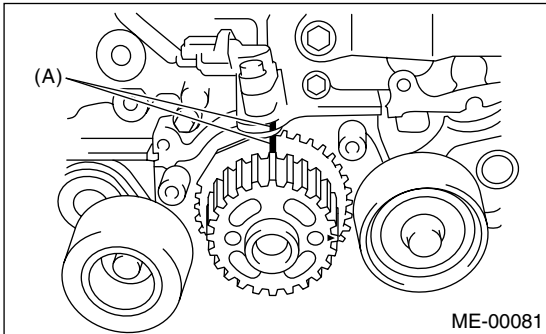

(2) Align single line mark (A) on the exhaust camshaft sprocket (RH) with notch (B) on timing belt cover.

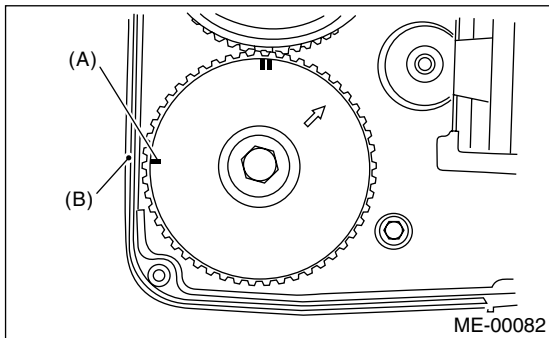

(3) Align single line mark (A) on the intake camshaft sprocket (RH) with notch (B) on timing belt cover.

(Make sure double lines (C) on intake camshaft and exhaust camshaft sprockets are aligned.)

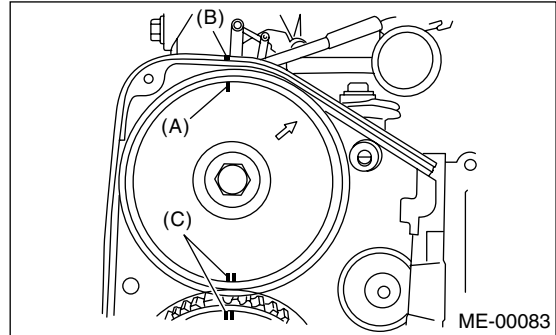

(4) Align single line mark (A) on exhaust camshaft sprocket (LH) with notch (B) on timing belt cover by turning the sprocket counterclockwise (as viewed from front of engine).

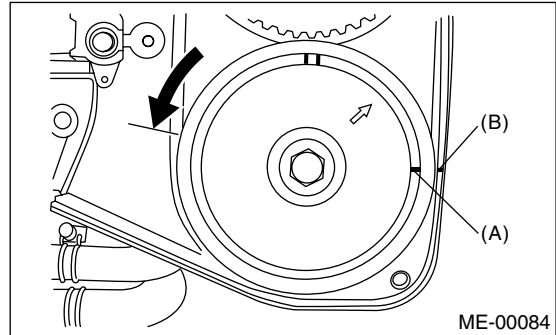

(5) Align the single line mark (A) on intake camshaft sprocket (LH) with notch (B) on timing belt cover by turning the sprocket clockwise (as viewed from front of engine).

Ensure the double lines (C) on intake and exhaust camshaft sprockets are aligned.

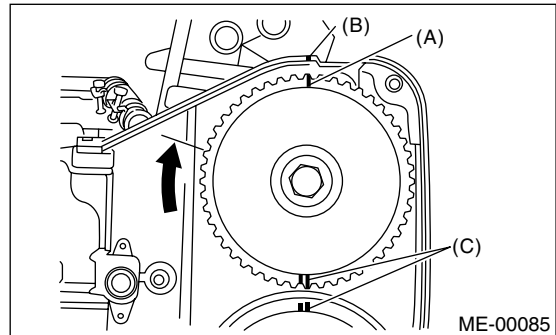

(6) Ensure the camshaft and crankshaft sprockets are positioned properly.

CAUTION:

• Intake and exhaust camshafts for this DOHC engine can be independently rotated with the timing belts removed. As can be seen from the figure, if the intake and exhaust valves are lifted simultaneously, their heads will interfere with each other, resulting in bent valves.

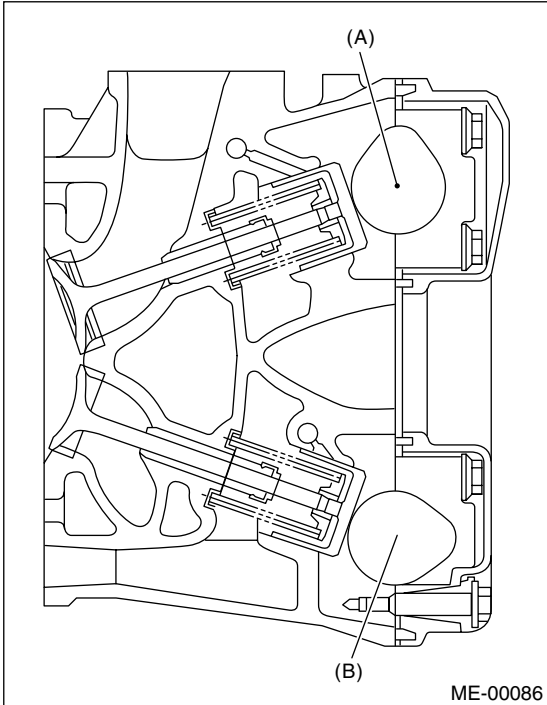

(A) Intake camshaft
(B) Exhaust camshaft

- When the timing belts are not installed, four camshafts are held at the “zero-lift” position, where all cams on camshafts do not push the intake and exhaust valves down. (Under this condition, all valves remain unlifted.)
- When the camshafts are rotated to install the timing belts, #2 intake and #4 exhaust cam of camshafts (LH) are held to push their corresponding valves down. (Under this condition, these valves are held lifted.) Camshafts (RH) are held so that their cams do not push valves down.
- Camshafts (LH) must be rotated from the “zero-lift” position to the position where the timing belt is to be installed at as small an angle as possible, in order to prevent mutual interference of intake and exhaust valve heads.

- Do not allow the camshafts to rotate in the direction shown in the figure as this causes both intake and exhaust valves to lift simultaneously, resulting in interference with their heads.

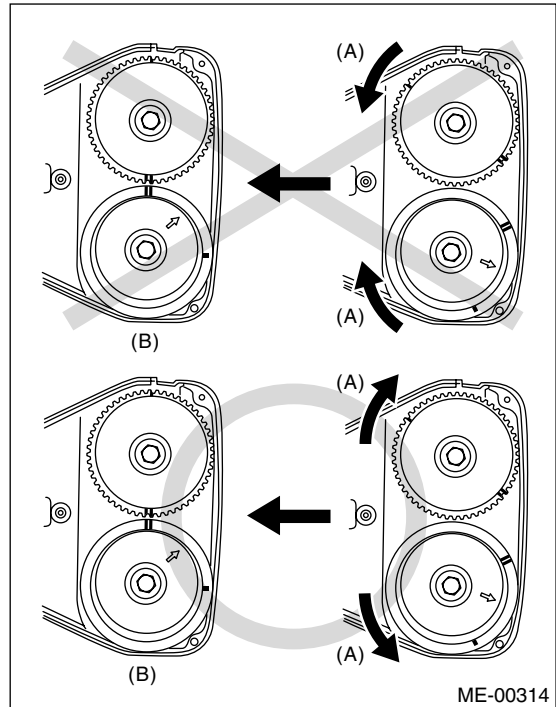

(A) Rotating direction
(B) Timing belt installation position

3) Installation of timing belt:

Align the alignment mark on timing belt with marks on sprockets in alphabetical order shown in the figure. While aligning marks, position the timing belt properly.

CAUTION:

- Disengagement of more than three timing belt teeth may result in interference between the valve and piston.

TIMING BELT ASSEMBLY

MECHANICAL

- Ensure the belt's rotating direction is correct.

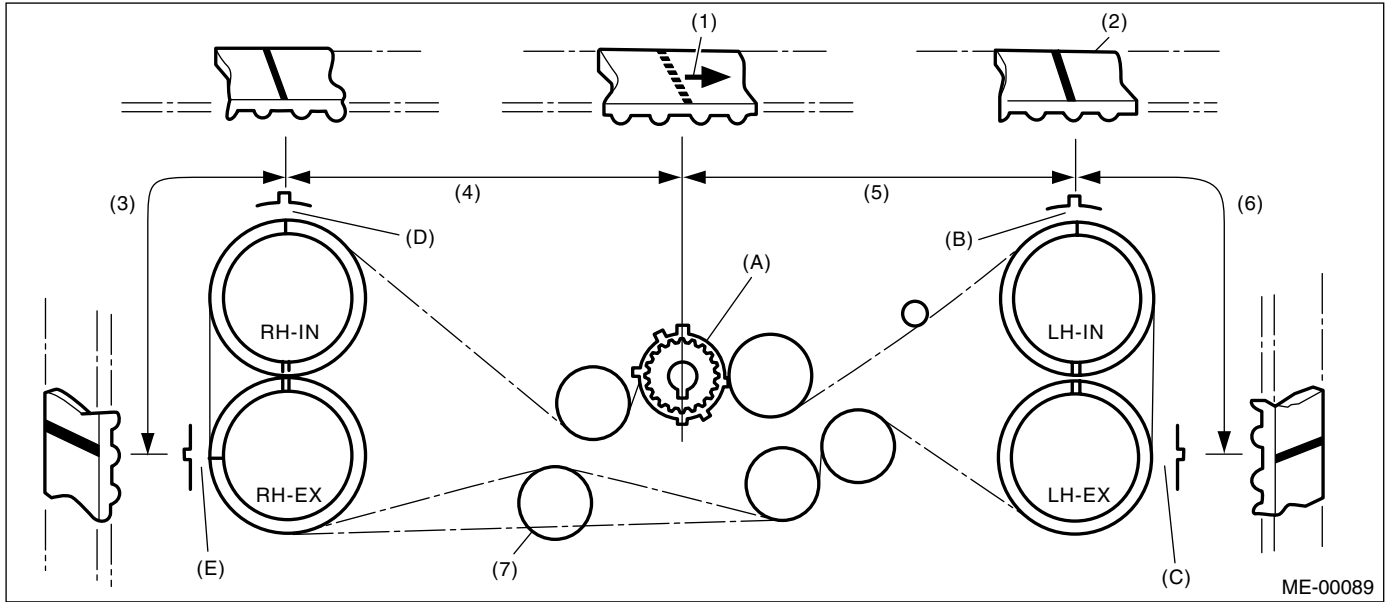

- (1) Arrow mark
- (2) Timing belt
- (3) 28 tooth length
- (4) 54.5 tooth length
- (5) 51 tooth length
- (6) 28 tooth length
- (7) Install it in the end

4) Install the belt idlers.

Tightening torque:

39 N·m (4.0 kgf-m, 28.9 ft-lb)

NOTE:

Make sure that the marks on the timing belt and sprockets are aligned.

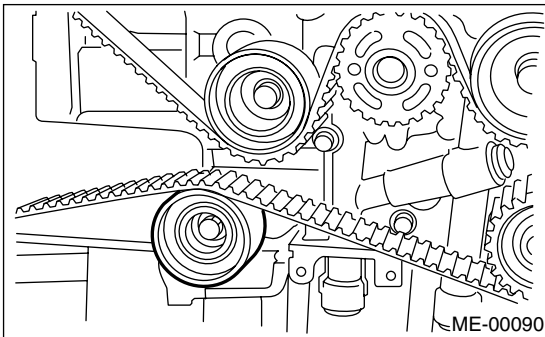

5) After ensuring that the marks on the timing belt and sprockets are aligned, remove the stopper pin from tensioner adjuster.

6) Install the timing belt guide. (MT model)

- (1) Temporarily tighten the bolts.
- (2) Check and adjust the clearance between timing belt and timing belt guide.

TIMING BELT ASSEMBLY

MECHANICAL

Clearance:

1.0 ± 0.5 mm (0.039 ± 0.020 in)

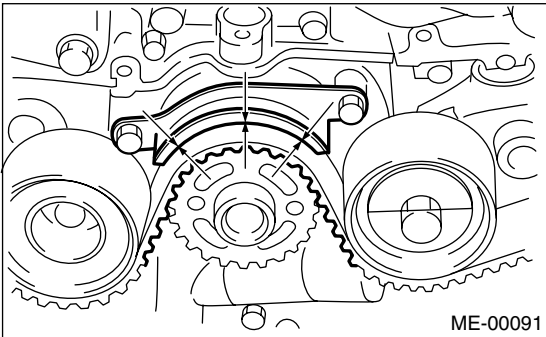

Tightening torque:

10 N·m (1.0 kgf·m, 7.2 ft·lb)

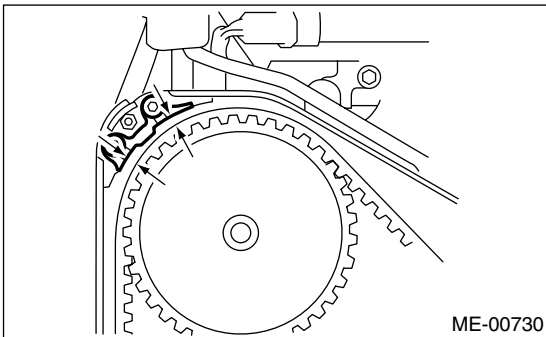
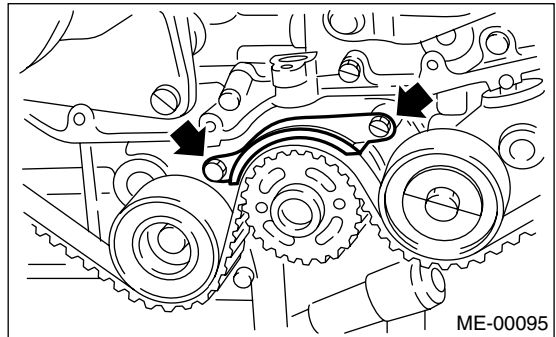

Tightening torque:

6.4 N·m (0.7 kgf·m, 5.1 ft·lb)

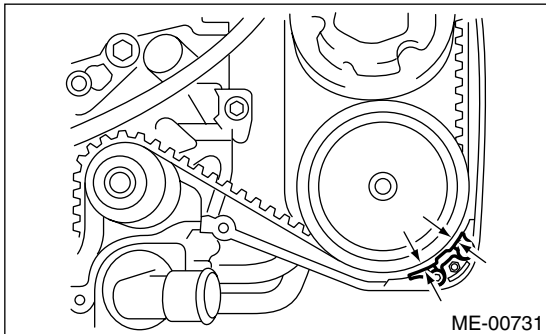
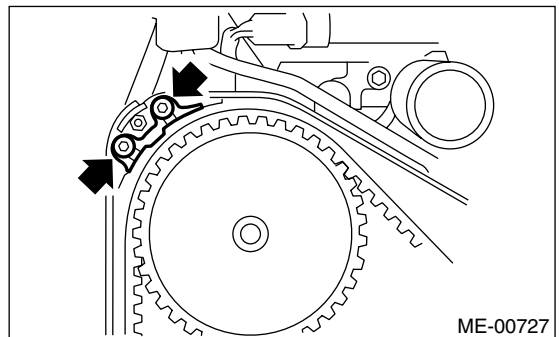

Tightening torque:

6.4 N·m (0.7 kgf·m, 5.1 ft·lb)

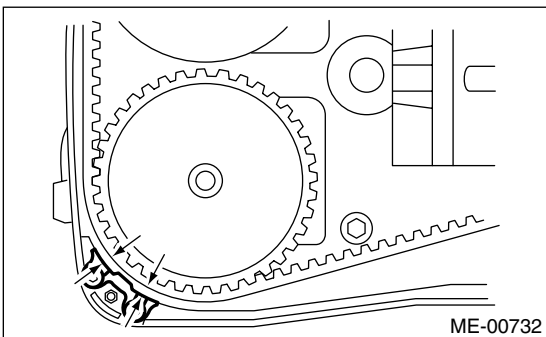
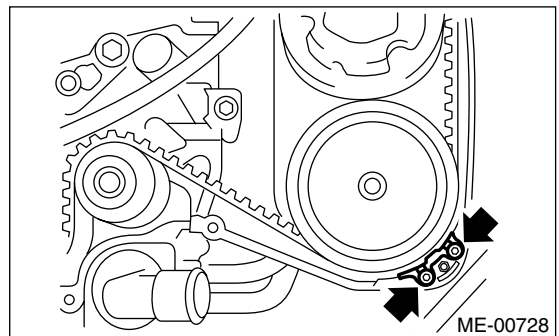

Tightening torque:

6.4 N·m (0.7 kgf·m, 5.1 ft·lb)

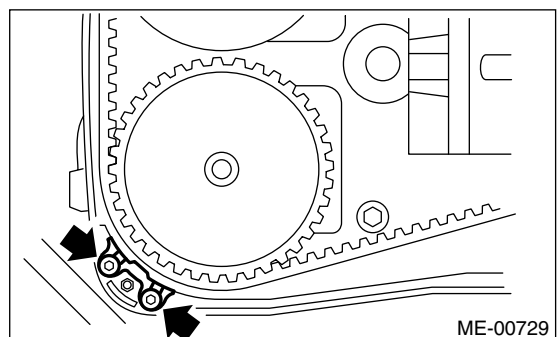

(3) Tighten the bolts.

TIMING BELT ASSEMBLY

MECHANICAL

7) Install the timing belt cover. <Ref. to ME(H4DOTC)-48, INSTALLATION, Timing Belt Cover.>

8) Install the crankshaft pulley. <Ref. to ME(H4DOTC)-47, INSTALLATION, CRANKSHAFT PULLEY.>

9) Install the V-belt. <Ref. to ME(H4DOTC)-45, INSTALLATION, V-belt.>

C: INSPECTION

1. TIMING BELT

1) Check the timing belt teeth for breaks, cracks, and wear. If any fault is found, replace the belt.

2) Check the condition of back side of belt; if any crack is found, replace the belt.

NOTE:

- Be careful not to let oil, grease or coolant contact the belt. Remove quickly and thoroughly if this happens.
- Do not bend the belt sharply.

Bending radius: h

60 mm (2.36 in) or more

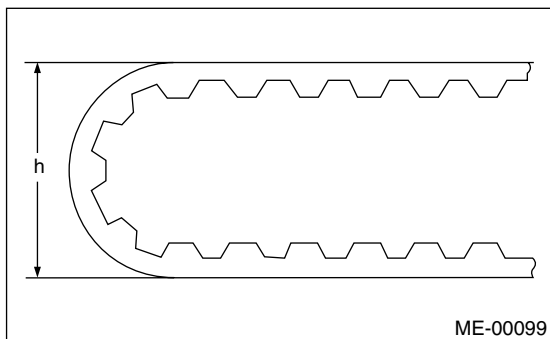

2. AUTOMATIC BELT TENSION ADJUSTER

1) Visually check the oil seals for leaks, and rod ends for abnormal wear or scratches. If necessary, replace the automatic belt tension adjuster assembly.

NOTE:

Slight traces of oil at rod's oil seal does not indicate a problem.

2) Check that the adjuster rod does not move when a pressure of 294 N (30 kgf, 66 lb) is applied to it. This is to check adjuster rod stiffness.

3) If the adjuster rod is not stiff and moves freely when applying 294 N (30 kgf, 66 lb), check it using the following procedures:

- (1) Slowly press the adjuster rod down to the end surface of the cylinder. Repeat this motion 2 or 3 times.

(2) With the adjuster rod moved all the way up, apply a pressure of 294 N (30 kgf, 66 lb) to it. Check the adjuster rod stiffness.

(3) If the adjuster rod is not stiff and moves down, replace the automatic belt tension adjuster assembly with a new one.

NOTE:

- Always use a vertical type pressing tool to move the adjuster rod down.
 - Do not use a lateral type vise.
 - Push the adjuster rod vertically.
 - Press-in the push adjuster rod gradually taking more than 3 minutes.
 - Do not allow press pressure to exceed 9,807 N (1,000 kgf, 2,205 lb).
 - Press the adjuster rod as far as the end surface of the cylinder. Do not press the adjuster rod into the cylinder. Doing so may damage the cylinder.
- 4) Measure the extension of rod beyond the body. If it is not within specifications, replace with a new one.

Rod extension: H

5.7±0.5 mm (0.224±0.020 in)

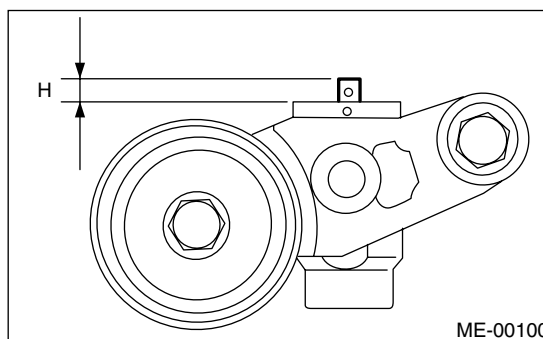

3. BELT TENSION PULLEY

1) Check the mating surfaces of timing belt and contact point of adjuster rod for abnormal wear or scratches. Replace the belt tension pulley if faulty.

2) Check the belt tension pulley for smooth rotation. Replace if noise or excessive play is noted.

3) Check the belt tension pulley for grease leakage.

4. BELT IDLER

1) Check the belt idler for smooth rotation. Replace if noise or excessive play is noted.

2) Check the outer contacting surfaces of idler pulley for abnormal wear and scratches.

3) Check the belt idler for grease leakage.

16. Camshaft Sprocket

A: REMOVAL

- 1) Remove the V-belt. <Ref. to ME(H4DOTC)-45, REMOVAL, V-belt.>
- 2) Remove the crankshaft pulley. <Ref. to ME(H4DOTC)-47, REMOVAL, Crankshaft Pulley.>
- 3) Remove the timing belt cover. <Ref. to ME(H4DOTC)-48, REMOVAL, Timing Belt Cover.>
- 4) Remove the timing belt assembly. <Ref. to ME(H4DOTC)-49, REMOVAL, Timing Belt Assembly.>
- 5) Remove the camshaft sprockets. To lock the camshaft, use ST.

ST 499207400 CAMSHAFT SPROCKET WRENCH

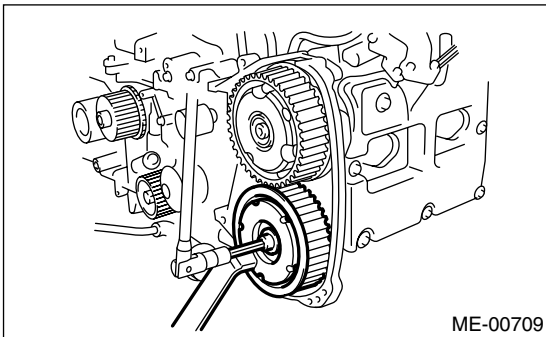

ST 499977500 CAMSHAFT SPROCKET WRENCH

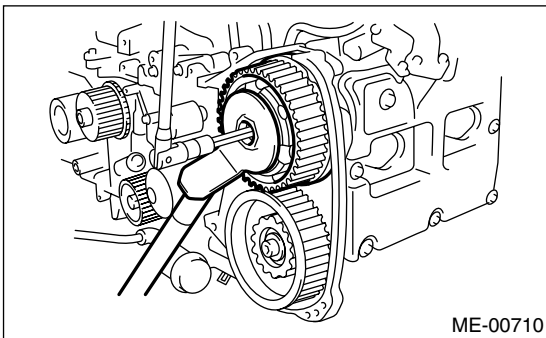

B: INSTALLATION

- 1) Install the camshaft sprocket. To lock the camshaft, use ST.

NOTE:

Do not confuse camshaft sprockets (RH) and (LH) during installation.

ST 499207400 CAMSHAFT SPROCKET WRENCH

Tightening torque:

98 N·m (10 kgf-m, 72.4 ft-lb)

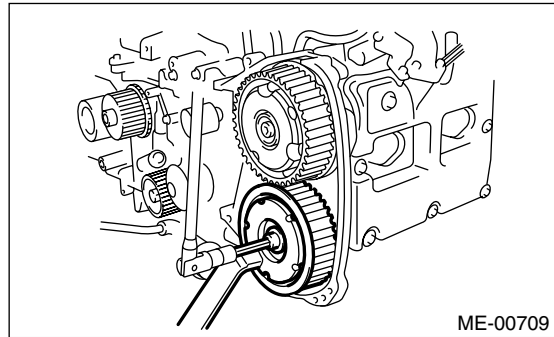

ST 499977500 CAMSHAFT SPROCKET WRENCH

Tightening torque:

29.5 N·m (3.0 kgf-m, 21.8 ft-lb), and then tighten 45° furthermore

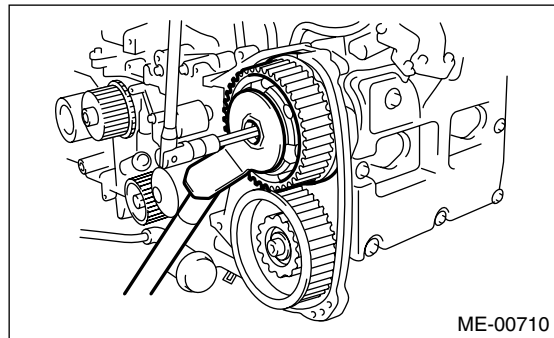

- 2) Install the timing belt assembly. <Ref. to ME(H4DOTC)-51, INSTALLATION, Timing Belt Assembly.>
- 3) Install the timing belt cover. <Ref. to ME(H4DOTC)-48, INSTALLATION, Timing Belt Cover.>
- 4) Install the crankshaft pulley. <Ref. to **ME(H4DOTC)-47, INSTALLATION, CRANKSHAFT PULLEY.**>
- 5) Install the V-belt. <Ref. to ME(H4DOTC)-45, INSTALLATION, V-belt.>

C: INSPECTION

- 1) Check the sprocket teeth for abnormal wear and scratches.
- 2) Make sure there is no free play between sprocket and key.
- 3) Check the crankshaft sprocket notch used for sensor for damage and contamination of foreign matter.

CRANKSHAFT SPROCKET

MECHANICAL

17.Crankshaft Sprocket

A: REMOVAL

- 1) Remove the V-belt. <Ref. to ME(H4DOTC)-45, REMOVAL, V-belt.>
- 2) Remove the crankshaft pulley. <Ref. to ME(H4DOTC)-47, REMOVAL, Crankshaft Pulley.>
- 3) Remove the timing belt cover. <Ref. to ME(H4DOTC)-48, REMOVAL, Timing Belt Cover.>
- 4) Remove the timing belt assembly. <Ref. to ME(H4DOTC)-58, REMOVAL, Crankshaft Sprocket.>
- 5) Remove the camshaft sprocket. <Ref. to ME(H4DOTC)-57, REMOVAL, Camshaft Sprocket.>
- 6) Remove the crankshaft sprocket.

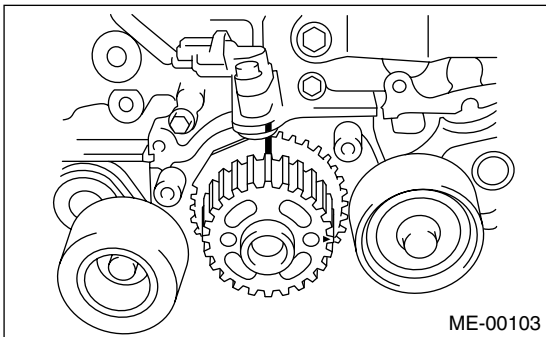

B: INSTALLATION

- 1) Install the crankshaft sprocket.

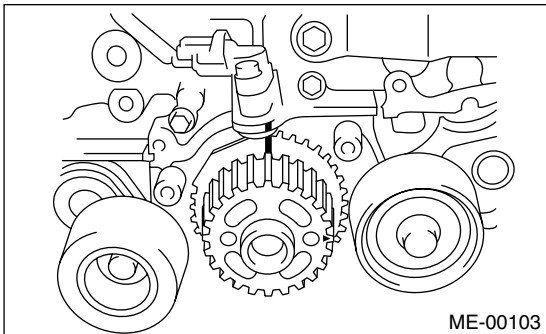

- 2) Install the camshaft sprocket. <Ref. to ME(H4DOTC)-57, INSTALLATION, Camshaft Sprocket.>
- 3) Install the timing belt assembly. <Ref. to ME(H4DOTC)-51, INSTALLATION, Timing Belt Assembly.>
- 4) Install the timing belt cover. <Ref. to ME(H4DOTC)-48, INSTALLATION, Timing Belt Cover.>
- 5) Install the crankshaft pulley. **<Ref. to ME(H4DOTC)-47, INSTALLATION, CRANKSHAFT PULLEY.>**
- 6) Install the V-belt. <Ref. to ME(H4DOTC)-45, INSTALLATION, V-belt.>

C: INSPECTION

- 1) Check the sprocket teeth for abnormal wear and scratches.
- 2) Make sure there is no free play between sprocket and key.
- 3) Check the crankshaft sprocket notch used for sensor for damage and contamination of foreign matter.

18. Camshaft

A: REMOVAL

- 1) Remove the V-belt. <Ref. to ME(H4DOTC)-45, REMOVAL, V-belt.>
- 2) Remove the crankshaft pulley. <Ref. to ME(H4DOTC)-47, REMOVAL, Crankshaft Pulley.>
- 3) Remove the timing belt cover. <Ref. to ME(H4DOTC)-48, REMOVAL, Timing Belt Cover.>
- 4) Remove the timing belt assembly. <Ref. to ME(H4DOTC)-49, REMOVAL, Timing Belt Assembly.>
- 5) Remove the camshaft sprocket. <Ref. to ME(H4DOTC)-47, REMOVAL, Crankshaft Pulley.>
- 6) Remove the crankshaft sprocket. <Ref. to ME(H4DOTC)-58, REMOVAL, Crankshaft Sprocket.>
- 7) Disconnect the variable valve timing solenoid valve assembly connector.

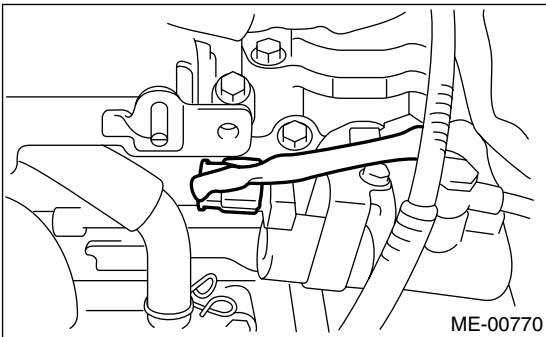

- 8) Remove the tensioner bracket.

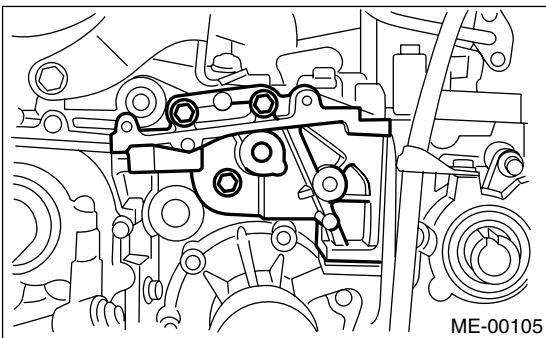

- 9) Remove the timing belt cover No. 2 (LH).

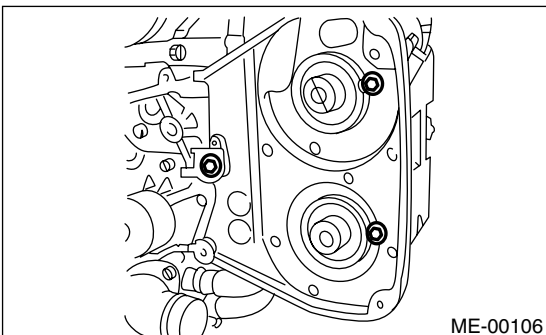

- 10) Remove the timing belt cover No.2 (RH).

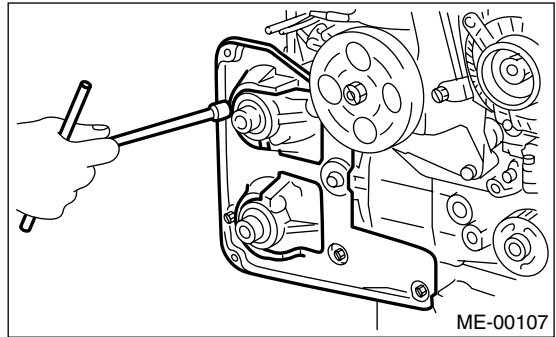

- 11) Remove the spark plug cord.
- 12) Remove the oil level gauge guide. (LH side)
- 13) Remove the rocker cover and gasket.
- 14) Remove the oil pipe.

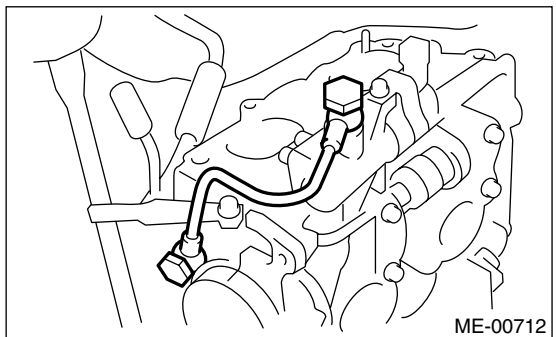

- 15) Loosen the variable valve timing solenoid valve assembly and intake camshaft cap bolts equally, a little at a time in alphabetical sequence shown in the figure.

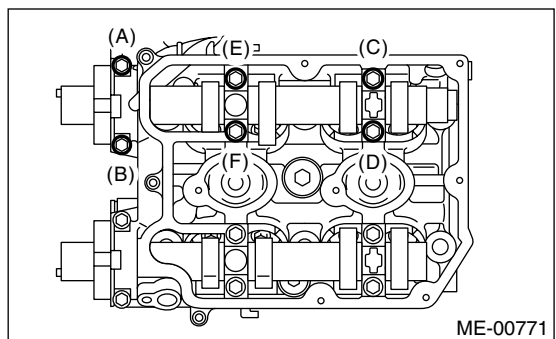

- 16) Remove the variable valve timing solenoid valve assembly, intake camshaft cap, and camshaft.

CAMSHAFT

MECHANICAL

17) Loosen the exhaust camshaft cap bolts equally, a little at a time in alphabetical sequence shown in the figure.

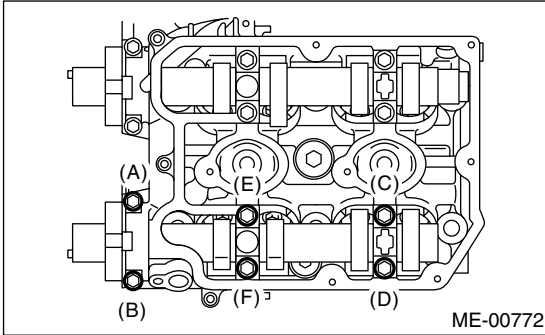

18) Remove the exhaust camshaft cap and camshaft.

NOTE:

Arrange the camshaft caps in order so that they can be installed in their original positions.

19) Similarly, remove the camshafts (RH) and related parts.

B: INSTALLATION

1) Camshaft installation: Apply engine oil to cylinder head at camshaft bearing location before installing the camshaft. Install the camshaft so that each valve is close to or in contact with “base circle” of cam lobe.

NOTE:

- When the camshafts are positioned as shown in the figure, camshafts need to be rotated at a minimum to align with the timing belt during installation.
- Camshaft (RH) need not be rotated when set at position shown in the figure. Intake camshaft (LH):

Rotate 80° clockwise. Exhaust camshaft (LH): Rotate 45° counterclockwise.

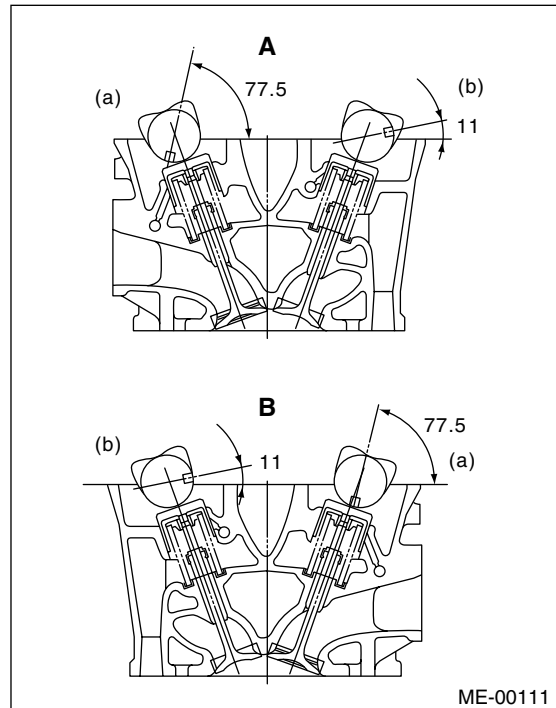

- A Cylinder head (LH)
- B Cylinder head (RH)
- (a) Intake camshaft
- (b) Exhaust camshaft

2) Camshaft cap and variable valve timing solenoid valve assembly installation:

- (1) Apply fluid packing sparingly to cap mating surface.

NOTE:

Do not apply fluid packing excessively. Failure to do so may cause excess packing to come out and flow toward the oil seal, resulting in oil leaks.

Fluid packing:

Part No. 004403007

THREE BOND 1215 or equivalent

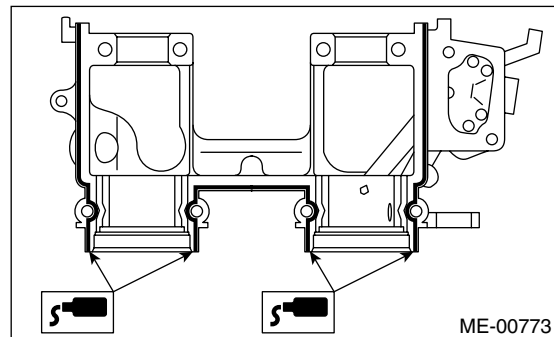

- (2) Apply engine oil to cap bearing surface and install the cap on camshaft as shown by identification mark (A).

(3) Gradually tighten the camshaft cap and oil control valve assembly in at least two stages in alphabetical sequence shown in the figure, and then tighten to specified torque.

Tightening torque:

- T1: 10 N·m (1.0 kgf-m, 7 ft-lb)**
- T2: 20 N·m (2.0 kgf-m, 14.5 ft-lb)**

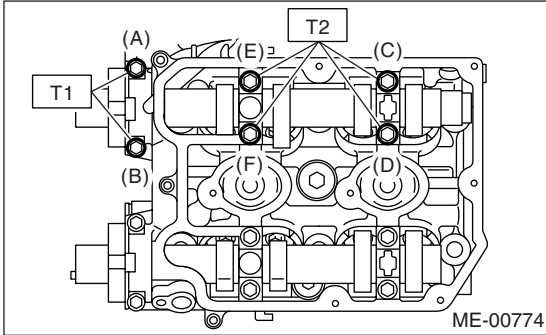

(4) Similarly, tighten cap on the exhaust side. After tightening cap, ensure the camshaft rotates only slightly while holding it at “base” circle.

Tightening torque:

- T1: 10 N·m (1.0 kgf-m, 7 ft-lb)**
- T2: 20 N·m (2.0 kgf-m, 14.5 ft-lb)**

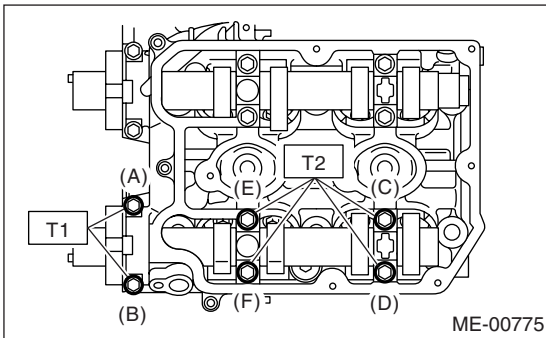

3) Camshaft oil seal installation: Apply grease to new oil seal lips and press onto front end of camshaft by using ST1 and ST2.

NOTE:

Use a new oil seal.

- ST1 499587600 OIL SEAL GUIDE
- ST2 499597200 OIL SEAL GUIDE

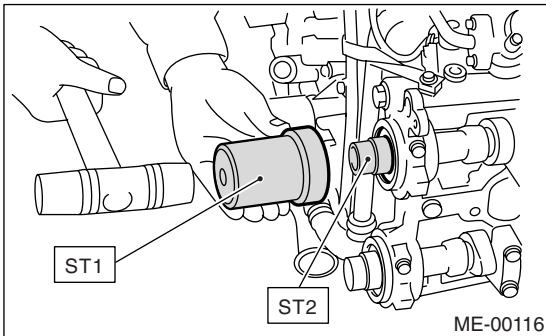

4) Rocker cover installation:

- (1) Install the gasket on rocker cover. Install the peripheral gasket and ignition coil gasket.
- (2) Apply fluid packing to the specified point of cylinder head.

Fluid packing:

Part No. 004403007

THREE BOND 1215 or equivalent

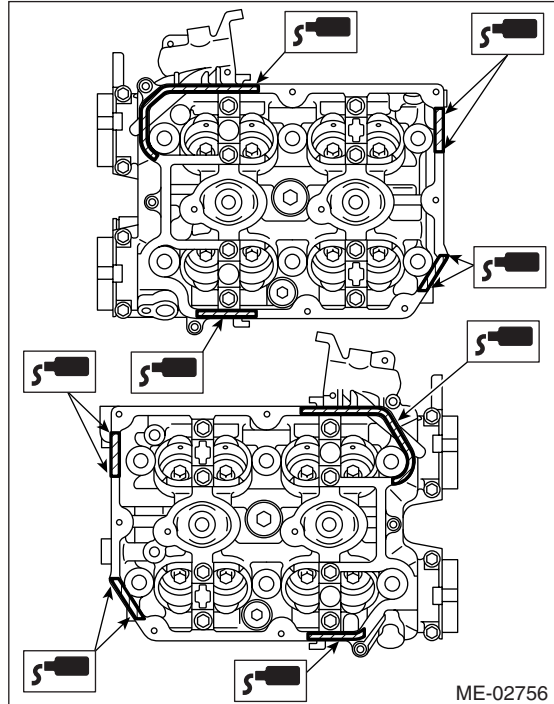

(3) Install the rocker cover on cylinder head. Ensure the gasket is properly positioned during installation.

(4) Tighten the rocker cover tightening bolt in alphabetical sequence shown in the figure, and then tighten to specified torque.

Tightening torque:

6.4 N·m (0.65 kgf-m, 4.7 ft-lb)

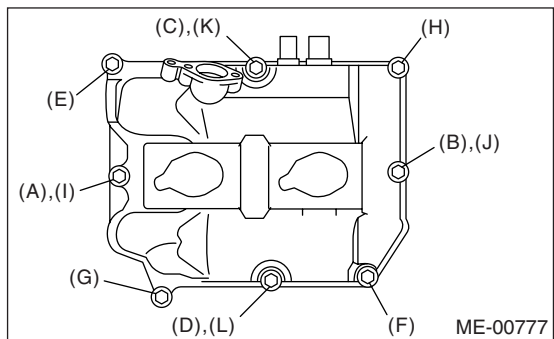

5) Install the oil pipe.

CAMSHAFT

MECHANICAL

Tightening torque:

29 N·m (3.0 kgf·m, 21.4 ft·lb)

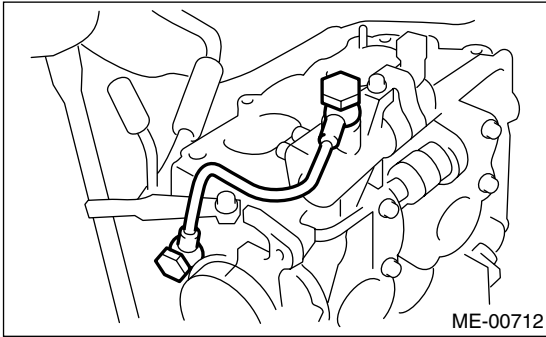

6) Connect the variable valve timing solenoid valve connector.

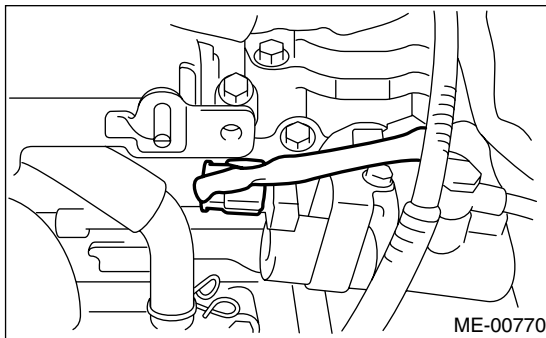

- 7) Install the spark plug cord.
- 8) Similarly, install the parts on right-hand side.
- 9) Install the timing belt cover No. 2 (RH).

Tightening torque:

5 N·m (0.5 kgf·m, 3.6 ft·lb)

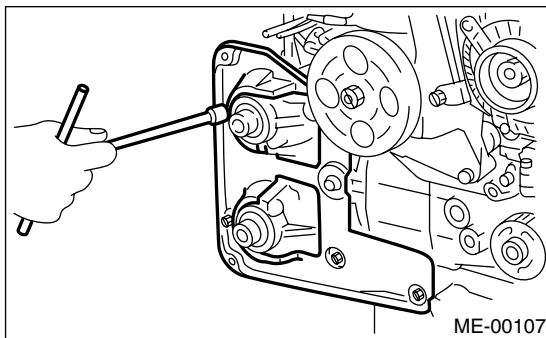

10) Install the timing belt cover No. 2 (LH).

Tightening torque:

5 N·m (0.5 kgf·m, 3.6 ft·lb)

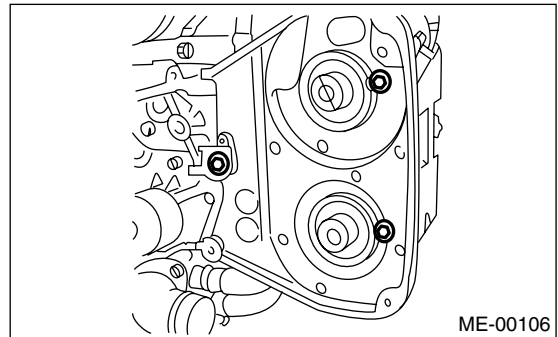

11) Install the tensioner bracket.

Tightening torque:

25 N·m (2.5 kgf·m, 18.1 ft·lb)

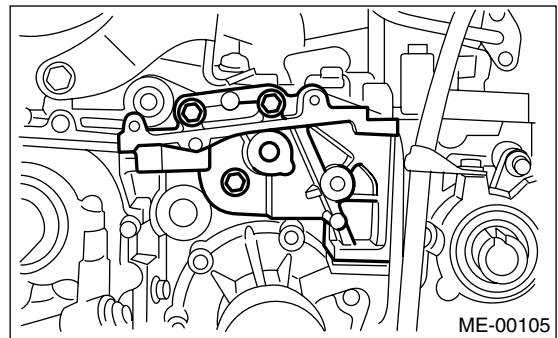

12) Install the crankshaft sprocket. **<Ref. to ME(H4DOTC)-58, INSTALLATION, CRANKSHAFT SPROCKET.>**

13) Install the camshaft sprockets. <Ref. to ME(H4DOTC)-57, INSTALLATION, Camshaft Sprocket.>

14) Install the timing belt assembly. <Ref. to ME(H4DOTC)-51, INSTALLATION, Timing Belt Assembly.>

15) Install the timing belt cover. <Ref. to ME(H4DOTC)-48, INSTALLATION, Timing Belt Cover.>

16) Install the crankshaft pulley. **<Ref. to ME(H4DOTC)-47, INSTALLATION, CRANKSHAFT PULLEY.>**

17) Install the V-belt. <Ref. to ME(H4DOTC)-45, INSTALLATION, V-belt.>

C: INSPECTION

1) Measure the bend, and repair or replace if necessary.

Limit:

0.020 mm (0.00079 in)

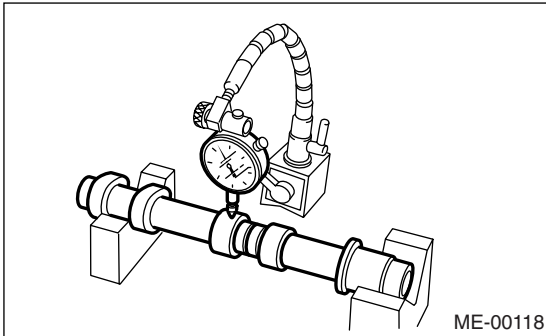

2) Check the journal for damage and wear. Replace if faulty.

3) Measure the outside diameter of camshaft journal. If the journal diameter is not as specified, check the oil clearance.

	Camshaft journal	
	Front	Center, rear
Standard	37.946 — 37.963 mm (1.4939 — 1.4946 in)	29.946 — 29.963 mm (1.1790 — 1.1796 in)

4) Measurement of the camshaft journal oil clearance:

- (1) Clean the bearing caps and camshaft journals.
- (2) Place the camshafts on cylinder head. (Without installing the valve rocker.)
- (3) Place a plastigauge across each of the camshaft journals.
- (4) Gradually tighten the cap in at least two stages in alphabetical sequence shown in the figure, and then tighten to specified torque. Do not turn the camshaft.

Tightening torque:

T1: 10 N·m (1.0 kgf·m, 7.2 ft·lb)

T2: 20 N·m (2.0 kgf·m, 14.5 ft·lb)

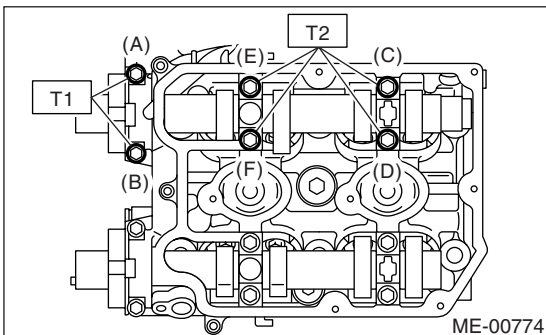

(5) Remove the bearing caps.

(6) Measure the widest point of plastigauge on each journal. If the oil clearance exceeds the limit, replace the camshaft. If necessary, replace the camshaft caps and cylinder head as a set.

Standard:

0.037 — 0.072 mm (0.0015 — 0.0028 in)

Limit:

0.10 mm (0.0039 in)

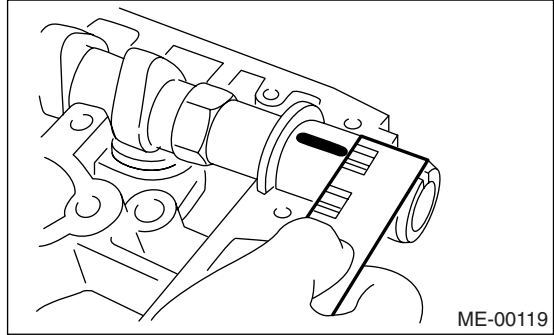

(7) Completely remove the plastigauge.

5) Check the cam face condition; remove the minor faults by grinding with oil stone. Measure the cam height H, replace if the limit has been exceeded.

Cam height: H

Standard:

Intake:

46.55 — 46.65 mm (1.833 — 1.837 in)

Exhaust:

46.75 — 46.85 mm (1.841 — 1.844 in)

Limit:

Intake:

46.45 mm (1.829 in)

Exhaust:

46.65 mm (1.837 in)

Cam base circle diameter A:

37.0 mm (1.457 in)

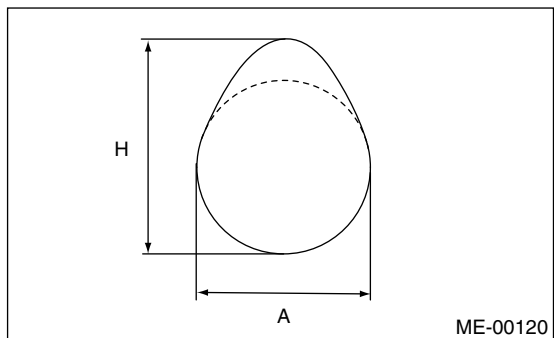

CAMSHAFT

MECHANICAL

6) Measure the thrust clearance of camshaft with dial gauge. If the clearance exceeds the limit, replace the caps and cylinder head as a set. If necessary, replace the camshaft.

Standard:

0.068 — 0.116 mm (0.0027 — 0.0046 in)

Limit:

0.14 mm (0.0055 in)

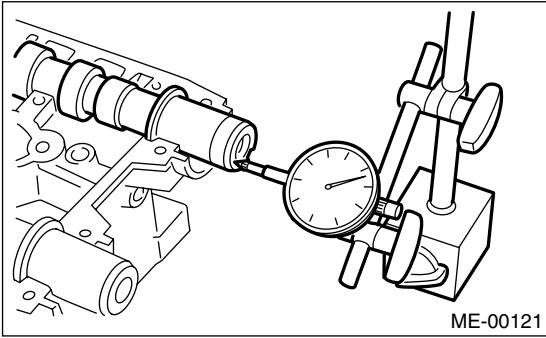

19. Cylinder Head Assembly

A: REMOVAL

- 1) Remove the V-belt. <Ref. to ME(H4DOTC)-45, REMOVAL, V-belt.>
- 2) Remove the crankshaft pulley. <Ref. to ME(H4DOTC)-47, REMOVAL, Crankshaft Pulley.>
- 3) Remove the timing belt cover. <Ref. to ME(H4DOTC)-48, REMOVAL, Timing Belt Cover.>
- 4) Remove the timing belt assembly. <Ref. to ME(H4DOTC)-49, REMOVAL, Timing Belt Assembly.>
- 5) Remove the camshaft sprocket. <Ref. to ME(H4DOTC)-57, REMOVAL, Camshaft Sprocket.>
- 6) Remove the intake manifold. <Ref. to FU(H4DOTC)-15, REMOVAL, Intake Manifold.>
- 7) Remove the bolt which installs the A/C compressor bracket on cylinder head.
- 8) Remove the camshaft. <Ref. to ME(H4DOTC)-59, REMOVAL, Camshaft.>
- 9) Remove the cylinder head bolts in alphabetical sequence shown in the figure.

Leave bolts (A) and (D) engaged by three or four threads to prevent the cylinder head from falling.

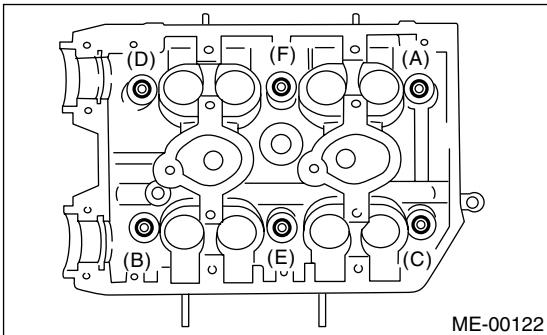

- 10) While tapping the cylinder head with a plastic hammer, separate it from cylinder block. Remove the bolts (A) and (D) to remove cylinder head.

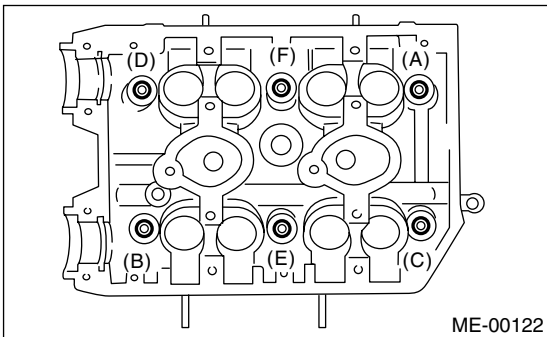

- 11) Remove the cylinder head gasket.

NOTE:

Do not scratch the mating surface of cylinder head and cylinder block.

- 12) Similarly, remove the cylinder head (RH).

B: INSTALLATION

- 1) Install the cylinder head and gaskets on cylinder block.

NOTE:

- Use new cylinder head gaskets.
 - Be careful not to scratch the mating surface of cylinder head and cylinder block.
- 2) Tighten the cylinder head bolts.
 - (1) Apply a coat of engine oil to the washers and bolt threads.
 - (2) Tighten all bolts to 29 N·m (3.0 kgf-m, 22 ft-lb) in alphabetical sequence.
 - (3) Tighten all bolts to 69 N·m (7.0 kgf-m, 51 ft-lb) in alphabetical sequence again.
 - (4) Back off all bolts by 180° first; back them off by 180° again in reverse order of installation.
 - (5) Tighten all bolts to 49 N·m (5.0 kgf-m, 36 ft-lb) in alphabetical sequence.
 - (6) Tighten all bolts 80 to 90° in alphabetical sequence.
 - (7) Tighten all bolts by 40 to 45° in alphabetical sequence again.

NOTE:

Do not tighten the bolts by more than 45°.

- (8) Further tighten all bolts (A) and (B) by 40 to 45°.

NOTE:

Ensure that the total “re-tightening angle” in the previous two steps do not exceed 90°.

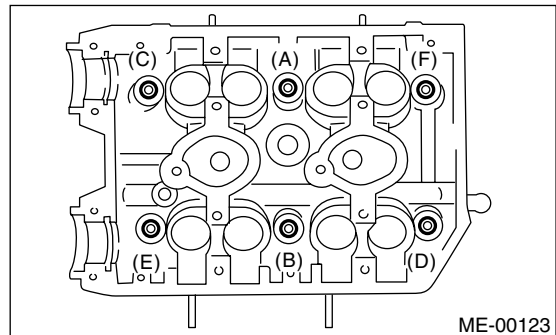

- 3) Install the camshaft. <Ref. to ME(H4DOTC)-60, INSTALLATION, Camshaft.>
- 4) Install the A/C compressor bracket on cylinder head.
- 5) Install the intake manifold. <Ref. to FU(H4DOTC)-17, INSTALLATION, Intake Manifold.>
- 6) Install the camshaft sprocket. <Ref. to ME(H4DOTC)-57, INSTALLATION, Camshaft Sprocket.>
- 7) Install the timing belt assembly. <Ref. to ME(H4DOTC)-51, INSTALLATION, Timing Belt Assembly.>

CYLINDER HEAD ASSEMBLY

MECHANICAL

8) Install the timing belt cover. <Ref. to ME(H4DOTC)-48, INSTALLATION, Timing Belt Cover.>

9) Install the crankshaft pulley. <Ref. to **ME(H4DOTC)-47, INSTALLATION, CRANKSHAFT PULLEY.**>

10) Install the V-belt. <Ref. to ME(H4DOTC)-45, INSTALLATION, V-belt.>

C: DISASSEMBLY

1) Remove the valve lifters.

2) Compress the valve spring and remove the valve spring retainer key. Remove each valve and valve spring.

ST1 498267600 CYLINDER HEAD TABLE

ST2 499718000 VALVE SPRING REMOVER

NOTE:

- Keep the removed parts in order for re-installing in their original positions.
- Mark each valve to prevent confusion.
- Use extreme care not to damage the lips of the intake valve oil seals and exhaust valve oil seals.

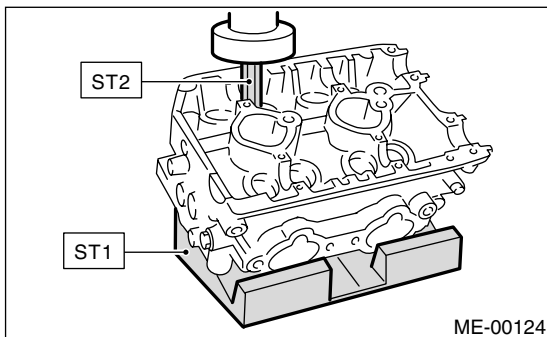

CYLINDER HEAD ASSEMBLY

MECHANICAL

D: ASSEMBLY

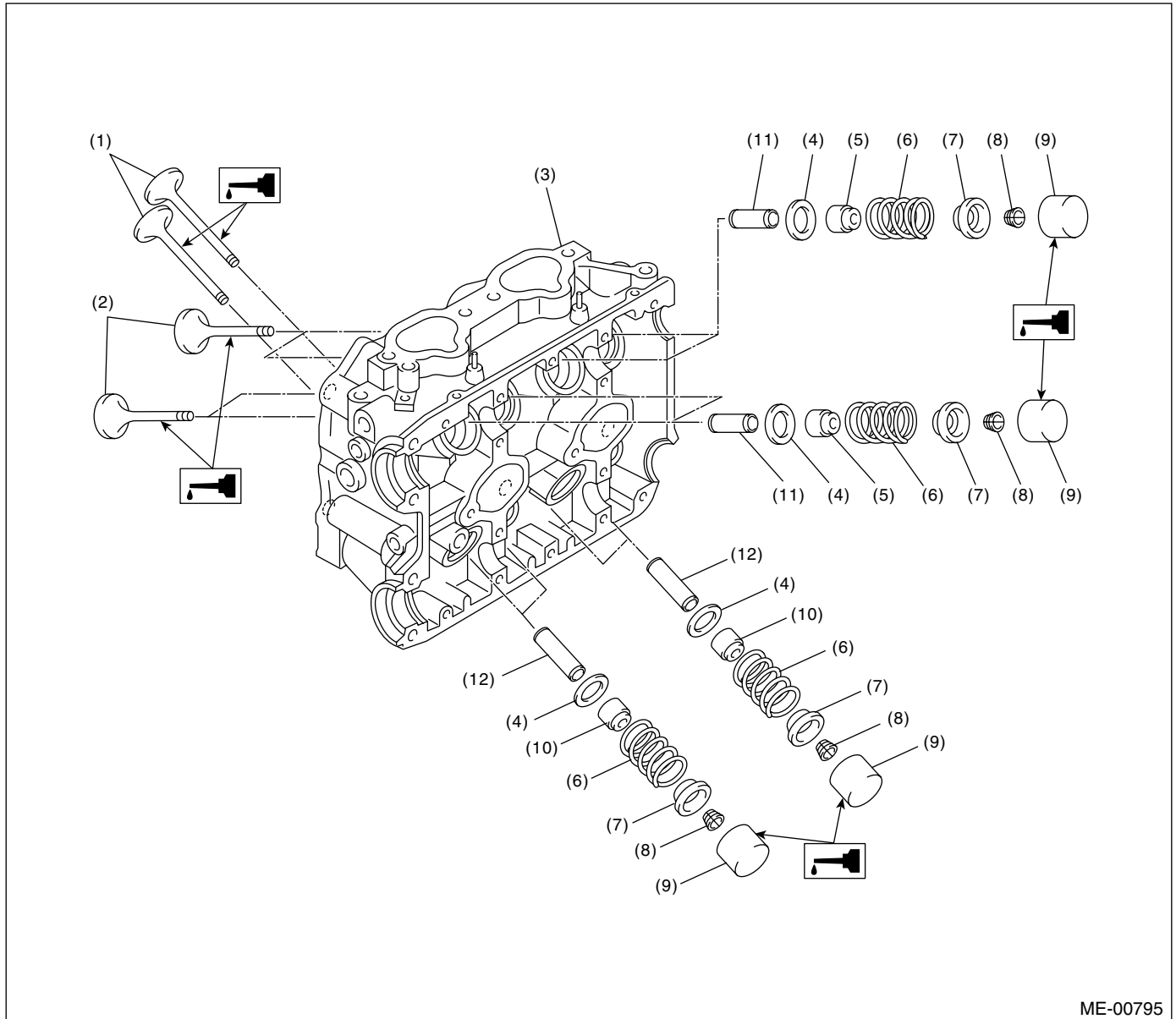

ME-00795

- (1) Exhaust valve
- (2) Intake valve
- (3) Cylinder head
- (4) Valve spring seat

- (5) Intake valve oil seal
- (6) Valve spring
- (7) Retainer
- (8) Retainer key

- (9) Valve lifter
- (10) Exhaust valve oil seal
- (11) Intake valve guide
- (12) Exhaust valve guide

CYLINDER HEAD ASSEMBLY

MECHANICAL

1) Installation of valve spring and valve:

- (1) Coat the stem of each valve with engine oil and insert the valve into valve guide.

NOTE:

When inserting the valve into valve guide, use special care not to damage the oil seal lip.

- (2) Set the cylinder head on ST1.
- (3) Install the valve spring and retainer using ST2.

ST1 4982676 00 CYLINDER HEAD TABLE
ST2 499718 000 VALVE SPRING REMOVER

NOTE:

Be sure to install the valve springs with their close-coiled end facing the seat on cylinder head.

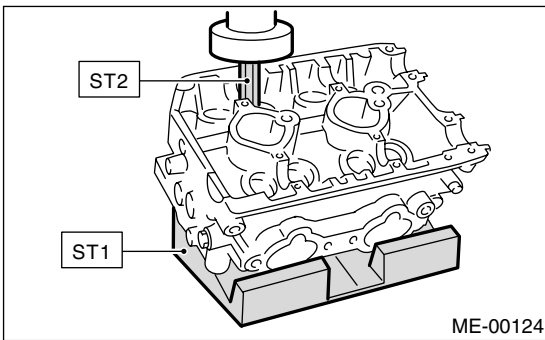

- (4) Compress the valve spring, and then fit the valve spring retainer key.
- (5) After installing, tap the valve spring retainers lightly with wooden hammer for better seating.

- 2) Apply oil to the surface of the valve lifter.
- 3) Install the valve lifter.

E: INSPECTION

1. CYLINDER HEAD

- 1) Make sure that no crack or other damage exists. In addition to visual inspection, inspect the important areas by means of red check.
- 2) Measure the warping of the cylinder head surface that mates with crankcase by using a straight edge (A) and thickness gauge (B). If the warping exceeds 0.05 mm (0.0020 in), re-grind the surface with a surface grinder.

Warping limit:

0.05 mm (0.0020 in)

Grinding limit:

0.3 mm (0.012 in)

Standard height of cylinder head:

127.5 mm (5.02 in)

NOTE:

Uneven torque for the cylinder head nuts can cause warping. When reassembling, pay special attention to the torque so as to tighten evenly.

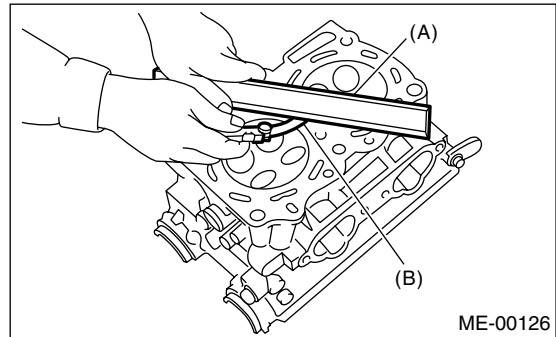

2. VALVE SEAT

Inspect the intake and exhaust valve seats, and then correct the contact surfaces with valve seat cutter if they are defective or when valve guides are replaced.

Valve seat width: W

Intake

Standard 1.0 mm (0.039 in)

Limit 1.7 mm (0.067 in)

Exhaust

Standard 1.5 mm (0.059 in)

Limit 2.2 mm (0.087 in)

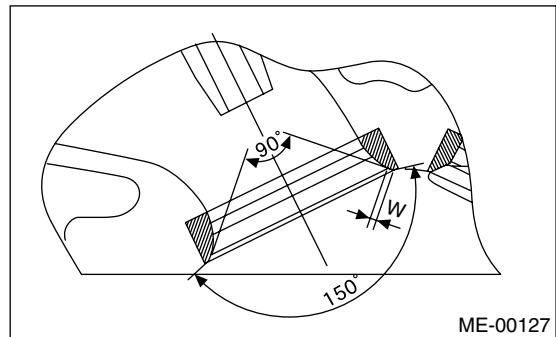

3. VALVE GUIDE

1) Check the clearance between valve guide and stem. The clearance can be checked by measuring the outside diameter of valve stem and the inside diameter of valve guide with outside and inside micrometers respectively.

Clearance between the valve guide and valve stem:

Standard

Intake

0.030 — 0.057 mm (0.0012 — 0.0022 in)

Exhaust

0.040 — 0.067 mm (0.0016 — 0.0026 in)

Limit

0.15 mm (0.0059 in)

2) If the clearance between valve guide and stem exceeds the limit, replace the valve guide or valve itself whichever shows greater amount of wear. See the following procedure for valve guide replacement.

Valve guide inner diameter:

6.000 — 6.012 mm (0.2362 — 0.2367 in)

Valve stem outer diameters:

Intake

5.955 — 5.970 mm (0.2344 — 0.2350 in)

Exhaust

5.945 — 5.960 mm (0.2341 — 0.2346 in)

(1) Place the cylinder head on ST1 with the combustion chamber upward so that valve guides enter the holes in ST1.

(2) Insert the ST2 into valve guide and press it down to remove the valve guide.

ST1 498267600 CYLINDER HEAD TABLE
ST2 499767200 VALVE GUIDE REMOVER

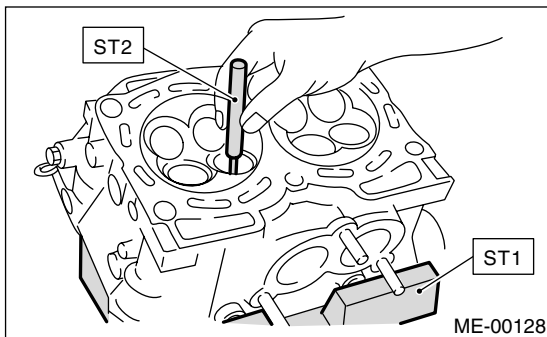

(3) Turn the cylinder head upside down and place ST as shown in the figure.

ST 18251AA020 VALVE GUIDE ADJUSTER

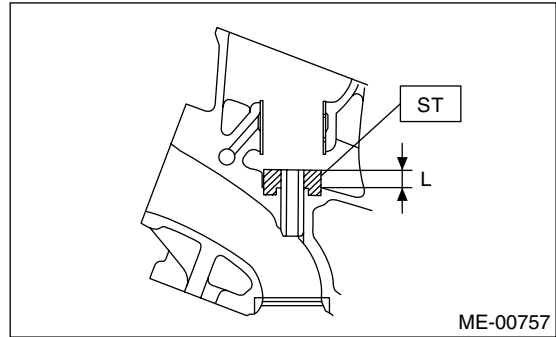

(4) Before installing a new valve guide, make sure that neither scratches nor damages exist on the inside surface of the valve guide holes in cylinder head.

(5) Put a new valve guide, coated with sufficient oil, in cylinder, and insert ST1 into valve guide. Press in until the valve guide upper end is flush with the upper surface of ST2.

ST1 499767200 VALVE GUIDE REMOVER
ST2 18251AA020 VALVE GUIDE ADJUSTER

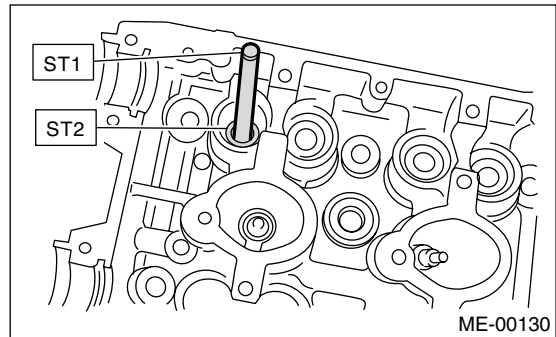

(6) Check the valve guide protrusion.

Valve guide protrusion: L

15.8 — 16.2 mm (0.622 — 0.638 in)

(7) Ream the inside of valve guide with ST. Gently rotate the reamer clockwise while pressing it lightly into the valve guide, and return it also rotating clockwise. After reaming, clean the valve guide to remove chips.

ST 499767400 VALVE GUIDE REAMER

NOTE:

- Apply engine oil to the reamer when reaming.
- If the inner surface of the valve guide is torn, the edge of the reamer should be slightly ground with an oil stone.
- If the inner surface of the valve guide becomes lustrous and the reamer does not chip, use a new reamer or remedy the reamer.

CYLINDER HEAD ASSEMBLY

MECHANICAL

(8) Recheck the contact condition between valve and valve seat after replacing the valve guide.

4. INTAKE AND EXHAUST VALVE

1) Inspect the flange and stem of valve, and replace if damaged, worn, or deformed, or if "H" is less than the specified limit.

H:

Intake (A)

Standard 1.2 mm (0.047 in)

Limit 0.8 mm (0.031 in)

Exhaust (B)

Standard 1.5 mm (0.059 in)

Limit 0.8 mm (0.031 in)

Valve overall length:

Intake (A)

104.4 mm (4.110 in)

Exhaust (B)

104.65 mm (4.120 in)

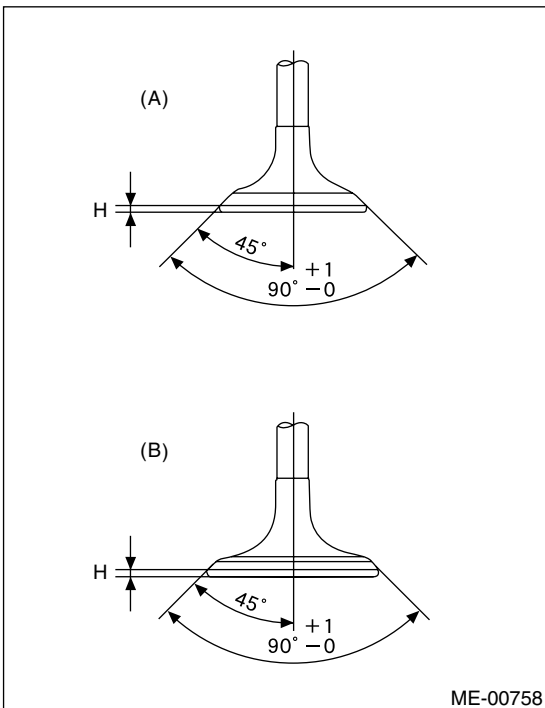

2) Put a small amount of grinding compound on the seat surface and lap the valve and seat surface. Install a new intake valve oil seal after lapping.

5. VALVE SPRINGS

1) Check the valve springs for damage, free length, and tension. Replace the valve spring if it is not within specifications presented in the table.

2) To measure the squareness of valve spring, stand the spring on a surface plate and measure its deflection at the top using a try square.

		Valve spring
Free length		47.32 mm (1.863 in)
Tension/spring height	Set	205 — 235 N (20.9 — 24.0 kgf, 46.1 — 52.8 lb) /36.0 mm (1.417 in)
	Lift	426 — 490 N (43.4 — 50.0 kgf, 95.8 — 110 lb) /26.45 mm (1.041 in)
Squareness		2.5°, 2.1 mm (0.083 in)

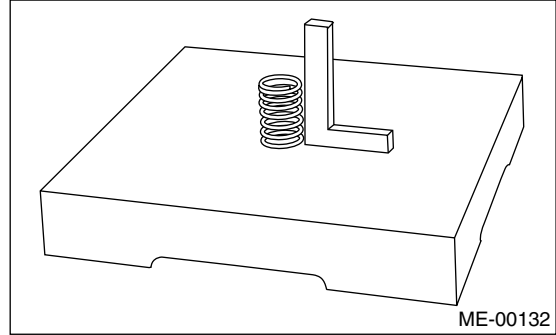

6. INTAKE AND EXHAUST VALVE OIL SEAL

Replace the oil seal with a new one, if the lip is damaged or spring out of place, or when the surfaces of intake valve and valve seat are reconditioned or intake valve guide is replaced.

- 1) Place the cylinder head on ST1.
- 2) Press in the oil seal to the specified dimension indicated in the figure by using ST2.

ST1 498267600 CYLINDER HEAD TABLE
ST2 498857100 VALVE OIL SEAL GUIDE

NOTE:

- Apply engine oil to oil seal before press-fit.
- Differentiate between the intake valve oil seal and exhaust valve oil seal by noting their difference in color.

Color of rubber part:

Intake [Black] Exhaust [Brown]

Color of spring part:

Intake [White] Exhaust [White]

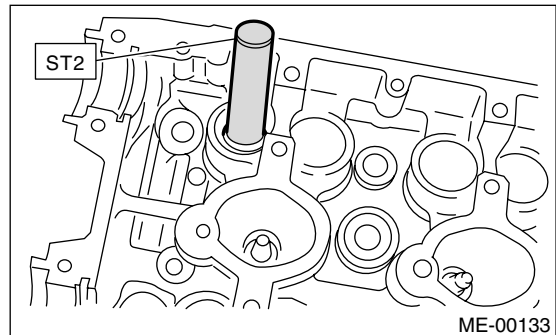

7. VALVE LIFTER

- 1) Visually check the valve lifter.
- 2) Measure the outer diameter of valve lifter.

Outer diameter:

34.959 — 34.975 mm (1.3763 — 1.3770 in)

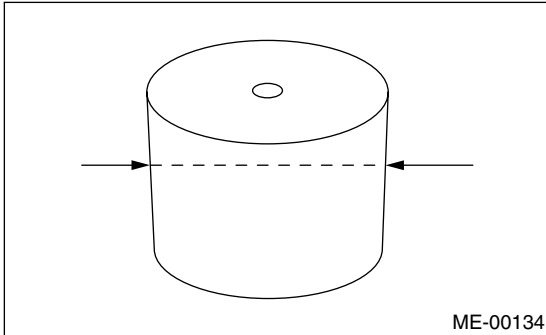

- 3) Measure the inner diameter of valve lifter mating part on cylinder head.

Inner diameter:

34.994 — 35.016 mm (1.3777 — 1.3786 in)

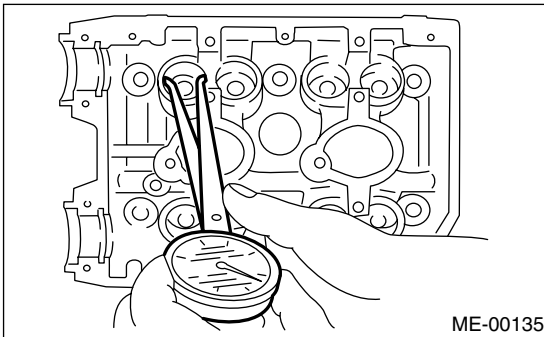

NOTE:

If difference between outer diameter of valve lifter and inner diameter of valve lifter mating part is over the limit, replace the cylinder head.

Standard:

0.019 — 0.057 mm (0.0007 — 0.0022 in)

Limit:

0.100 mm (0.0039 in)

F: DISPOSAL

CAUTION:

- Metallic sodium is enclosed in the exhaust valve. Metallic sodium is extremely alkaline and may produce severe chemical reactions. Full consideration must therefore be given to the following points when handling or disposing of the valve.
- Since metallic sodium may cause blindness if contacted with the eyes, burns if contacted with the skin, and fire, do not deliberately take the valve apart.

- 1) If the valve is damaged, remove the valve and neutralize it by immersing it in water, and dispose of it in the same way that general steel materials are disposed of. The disposal method is described in the following.

- (1) Wearing rubber gloves, remove the damaged valve from the cylinder head.
- (2) Prepare a large receptacle (bucket or other container) in a well ventilated location, and fill the receptacle with water (at least 10 liters).
- (3) Immerse the damaged valve in the receptacle.

CAUTION:

A severe reaction may occur, so stand at least 2 — 3 m from the receptacle. Because the reaction will produce hydrogen gas, moreover, keep the receptacle away from sparks or flames.

- (4) Once the reaction is completed (about 4 — 5 hours have elapsed), carefully remove the valve using large pincers so that the reaction liquid does not contact your skin, and dispose of it with other parts that are being disposed of.
- (5) The reaction liquid is a strong alkaline solution, so it must be disposed of in accordance with local regulations.

CAUTION:

Make sure the reaction liquid does not contact your skin. If contact with skin occurs, immediately wash the affected area with large quantities of water.

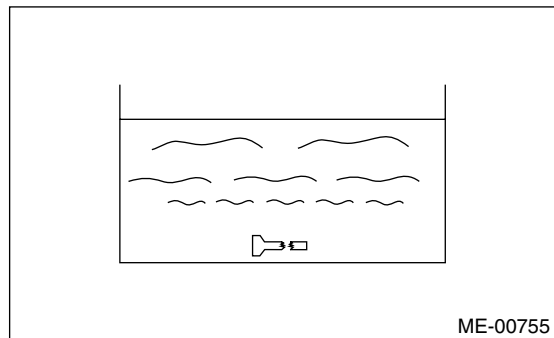

CYLINDER BLOCK

MECHANICAL

20. Cylinder Block

A: REMOVAL

NOTE:

Before conducting this procedure, drain the engine oil completely if applicable.

- 1) Remove the intake manifold. <Ref. to FU(H4DOTC)-15, REMOVAL, Intake Manifold.>
 - 2) Remove the V-belt. <Ref. to ME(H4DOTC)-45, REMOVAL, V-belt.>
 - 3) Remove the crankshaft pulley. <Ref. to ME(H4DOTC)-47, REMOVAL, Crankshaft Pulley.>
 - 4) Remove the timing belt cover. <Ref. to ME(H4DOTC)-48, REMOVAL, Timing Belt Cover.>
 - 5) Remove the timing belt assembly. <Ref. to ME(H4DOTC)-49, REMOVAL, Timing Belt Assembly.>
 - 6) Remove the camshaft sprocket. <Ref. to ME(H4DOTC)-57, REMOVAL, Camshaft Sprocket.>
 - 7) Remove the crankshaft sprocket. <Ref. to ME(H4DOTC)-58, REMOVAL, Crankshaft Sprocket.>
 - 8) Remove the generator and A/C compressor with their brackets.
 - 9) Remove the cylinder head assembly. <Ref. to ME(H4DOTC)-65, REMOVAL, Cylinder Head Assembly.>
 - 10) Remove the clutch disc and cover. <Ref. to CL-11, REMOVAL, Clutch Disc and Cover.>
 - 11) Remove the flywheel. (MT model) <Ref. to CL-11, REMOVAL, Clutch Disc and Cover.>
 - 12) Remove drive plate. (AT model)
- Using ST, lock crankshaft.

ST 498497100 CRANKSHAFT STOPPER

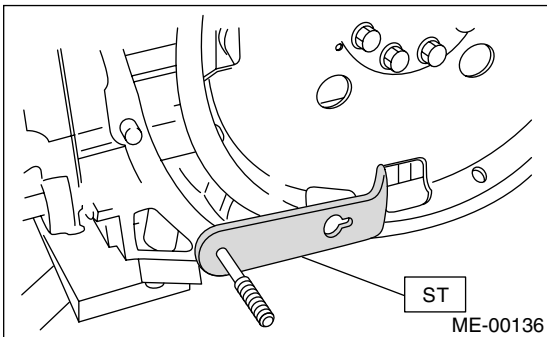

- 13) Remove the oil separator cover.
 - 14) Remove the water by-pass pipe for heater.
 - 15) Remove the oil filter.
- ST 18332AA000 OIL FILTER WRENCH (Outer diameter: 68 mm (2.68 in))
- ST 18332AA010 OIL FILTER WRENCH (Outer diameter: 65 mm (2.56 in))

- 16) Remove the oil cooler.

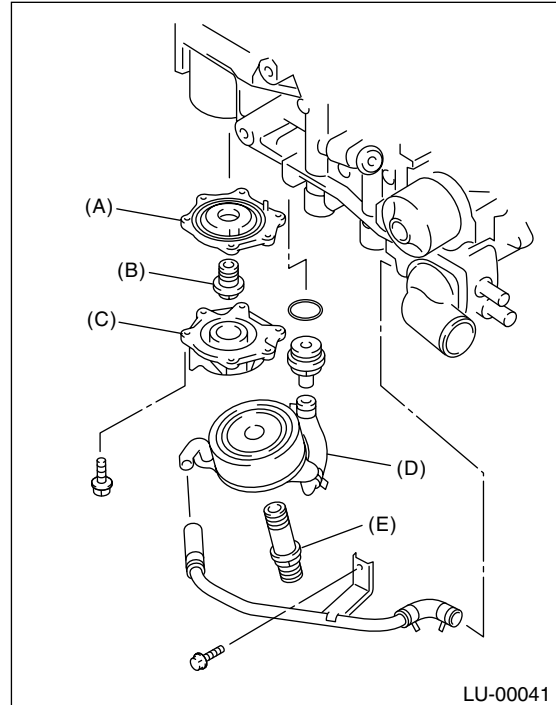

- (A) Adapter (1)
(B) Adapter connector
(C) Adapter (2)
(D) Oil cooler
(E) Oil cooler connector

- 17) Removal of oil pan:

- (1) Turn the cylinder block with #2 and #4 piston sides facing upward.
- (2) Remove the bolts which secure oil pan to cylinder block.
- (3) Insert an oil pan cutter blade between cylinder block-to-oil pan clearance, and then remove the oil pan.

Do not use a screwdriver or similar tool in place of oil pan cutter.

- 18) Remove the oil strainer stay.
 - 19) Remove the oil strainer.
 - 20) Remove the baffle plate.
 - 21) Remove the water pipes.
 - 22) Remove the water pump.
 - 23) Remove the oil pump from cylinder block.
- Use a flat-bladed screwdriver as shown in the figure when removing the oil pump.

CYLINDER BLOCK

MECHANICAL

NOTE:

Be careful not to scratch the mating surface of cylinder block and oil pump.

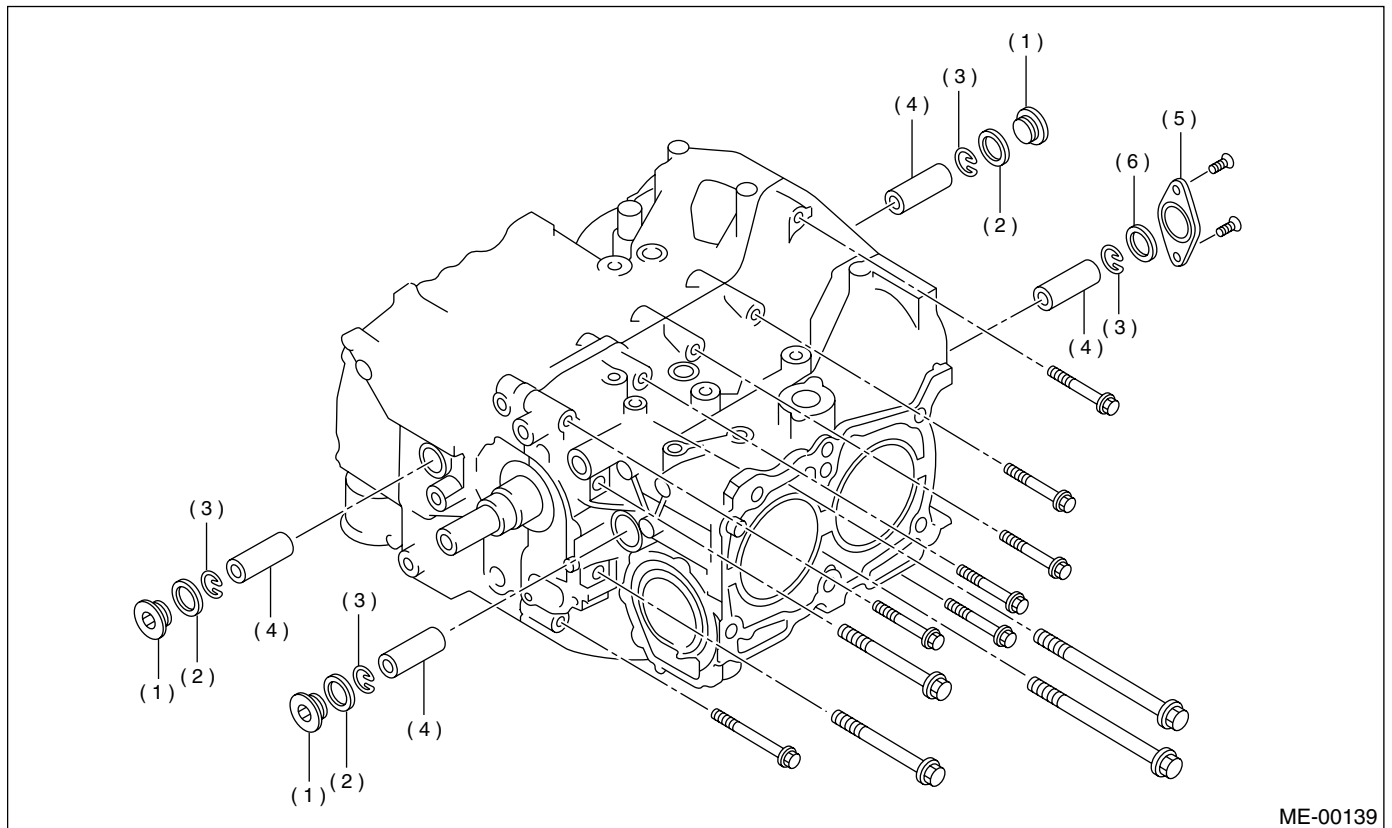
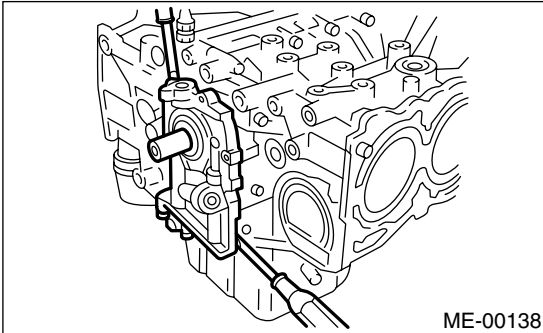

- (1) Service hole plug
- (2) Gasket

- (3) Circlip
- (4) Piston pin

- (5) Service hole cover
- (6) O-ring

CYLINDER BLOCK

MECHANICAL

24) Remove the service hole cover and service hole plugs using hexagon wrench [14 mm (0.55 in)].

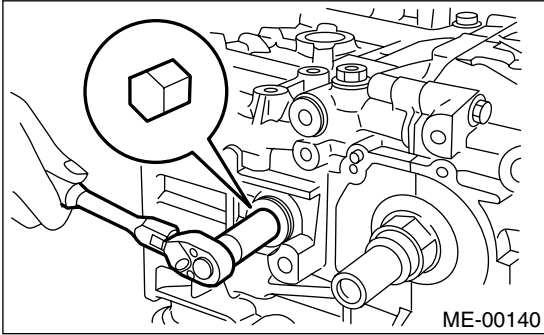

25) Rotate the crankshaft to bring #1 and #2 pistons to bottom dead center position, and then remove the piston circlip through service hole of #1 and #2 cylinders.

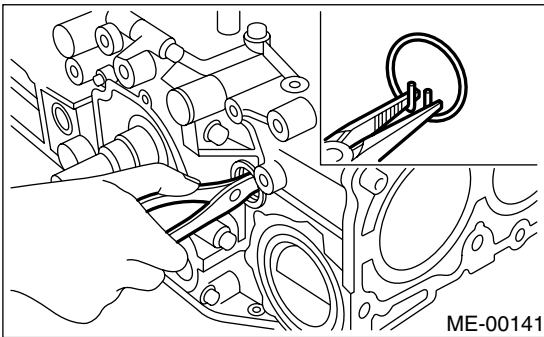

26) Draw out the piston pin from #1 and #2 pistons using ST.

ST 499097700 PISTON PIN REMOVER

NOTE:

Be careful not to confuse the original combination of piston, piston pin and cylinder.

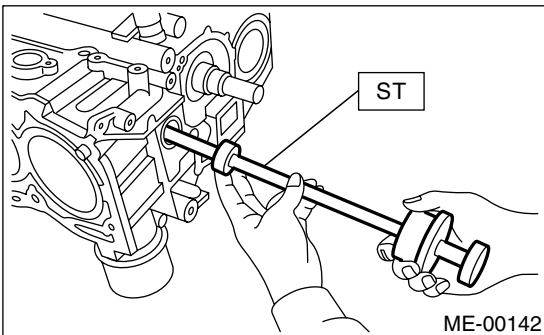

27) Similarly remove the piston pins from #3 and #4 pistons.

28) Remove the bolts which connect the cylinder block on the side of #2 and #4 cylinders.

29) Back off the bolts which connect the cylinder block on the side of #1 and #3 cylinders two or three turns.

30) Set up the cylinder block so that #1 and #3 cylinders are on the upper side, then remove the cylinder block connecting bolts.

31) Separate the cylinder blocks (LH) and (RH).

NOTE:

When separating the cylinder block, do not allow the connecting rod to fall and damage the cylinder block.

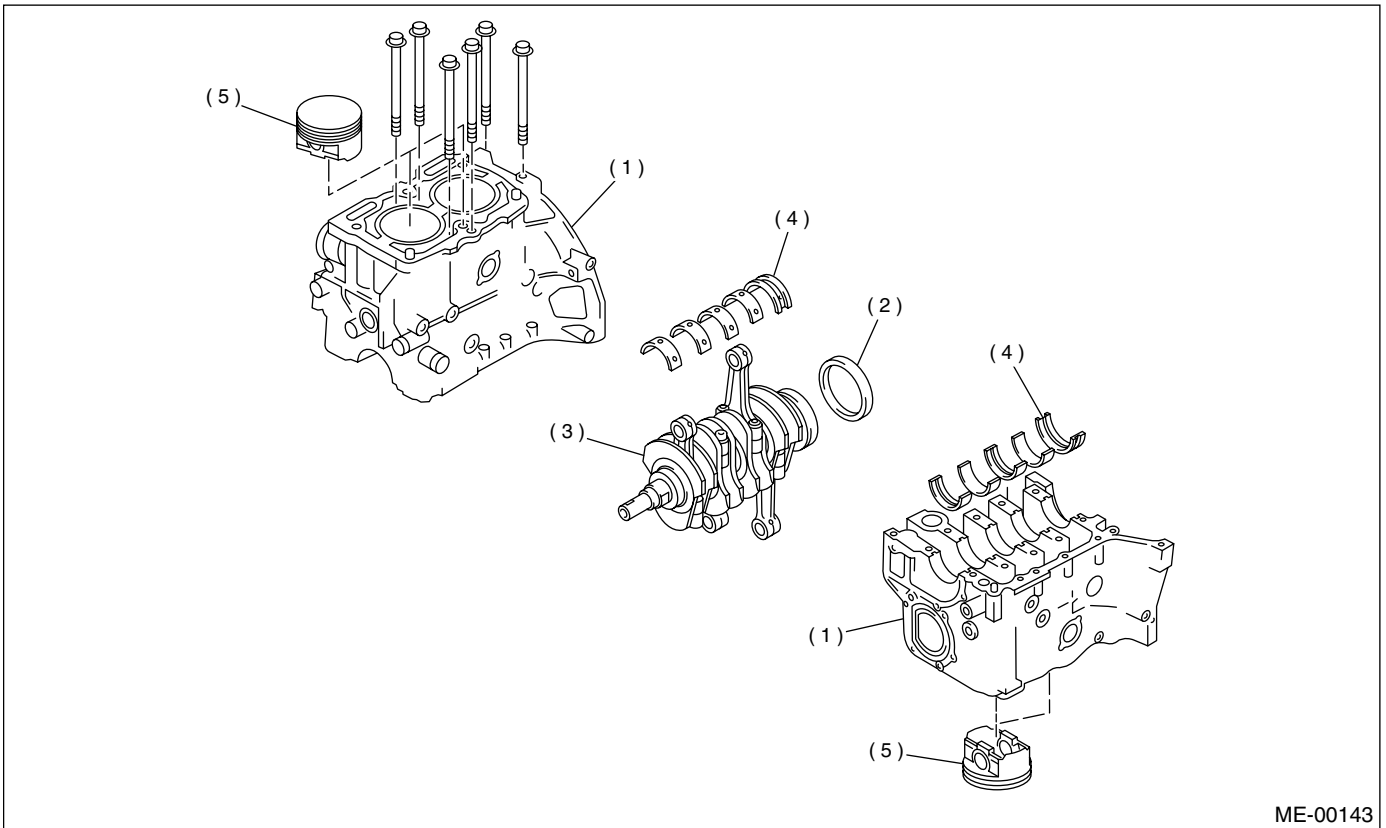

ME-00143

(1) Cylinder block

(3) Crankshaft

(5) Piston

(2) Rear oil seal

(4) Crankshaft bearing

32) Remove the rear oil seal.

33) Remove the crankshaft together with connecting rod.

34) Remove the crankshaft bearings from cylinder block using a hammer handle.

NOTE:

Do not confuse the combination of crankshaft bearings. Press the bearing at the end opposite to locking lip.

35) Draw out each piston from cylinder block using a wooden bar or hammer handle.

NOTE:

Do not confuse the combination of piston and cylinder.

CYLINDER BLOCK

MECHANICAL

B: INSTALLATION

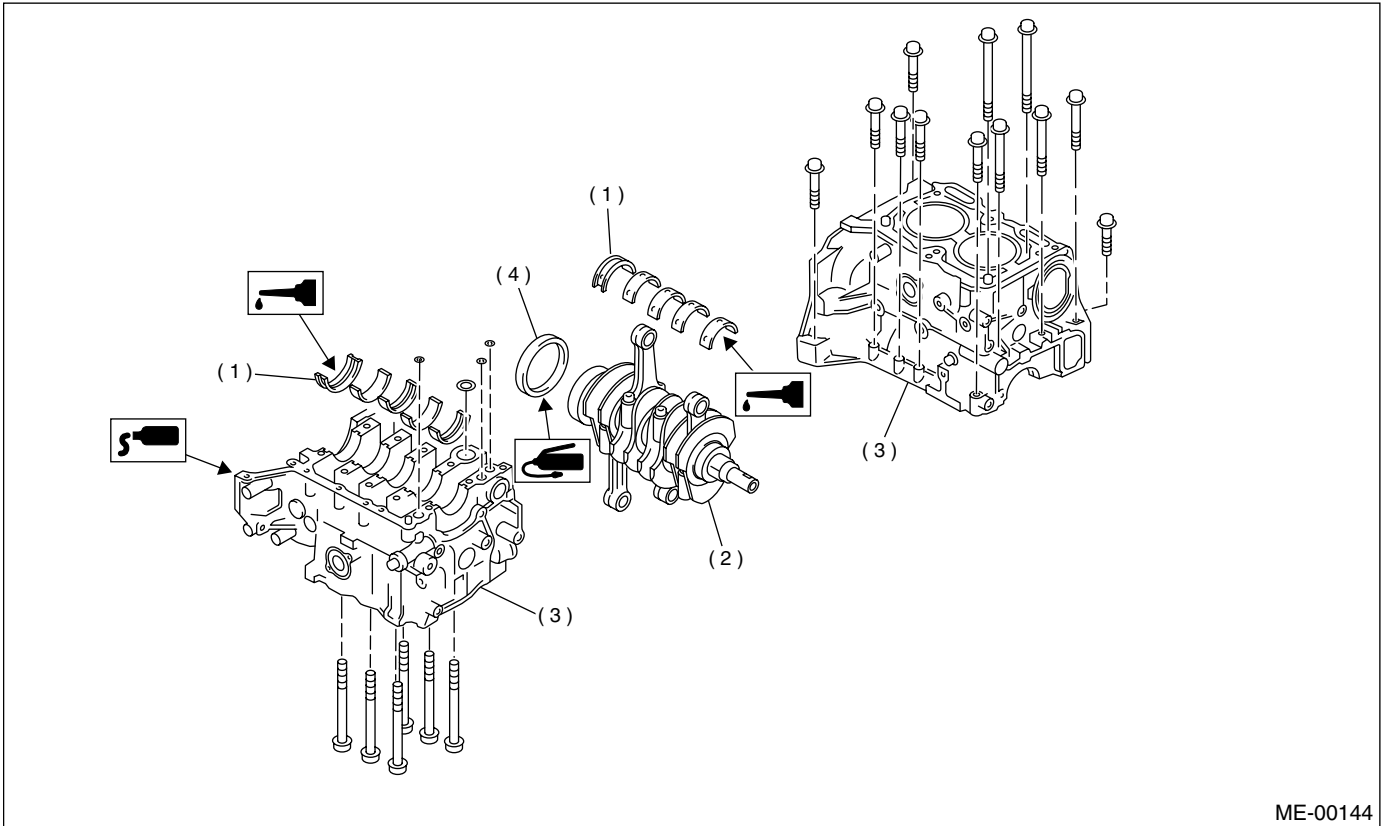

ME-00144

(1) Crankshaft bearing
(2) Crankshaft

(3) Cylinder block

(4) Rear oil seal

1) Remove oil in the mating surface of bearing and cylinder block before installation. Also apply a coat of engine oil to crankshaft pins.

2) Position the crankshaft on #2 and #4 cylinder block.

3) Apply fluid packing to the mating surface of #1 and #3 cylinder block, and position it on #2 and #4 cylinder block.

Fluid packing:

Part No. 004403007

THREE BOND 1215 or equivalent

NOTE:

Do not allow fluid packing to jut into O-ring grooves, oil passages, bearing grooves, etc.

4) Apply engine oil to washers and thread of bolts.
5) Tighten the 10 mm cylinder block connecting bolts in alphabetical sequence shown in the figure. (LH side)

Tightening torque:

10 N·m (1.0 kgf-m, 7.4 ft-lb)

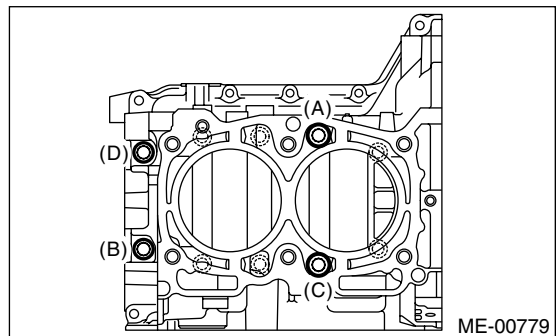

ME-00779

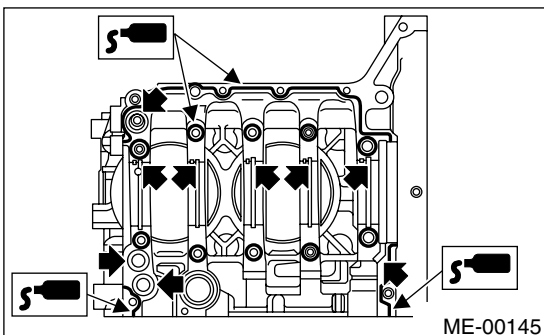

ME-00145

ME(H4DOTC)-76

CYLINDER BLOCK

MECHANICAL

6) Tighten the 10 mm cylinder block connecting bolts in alphabetical sequence shown in the figure. (RH side)

Tightening torque:

10 N·m (1.0 kgf·m, 7.4 ft-lb)

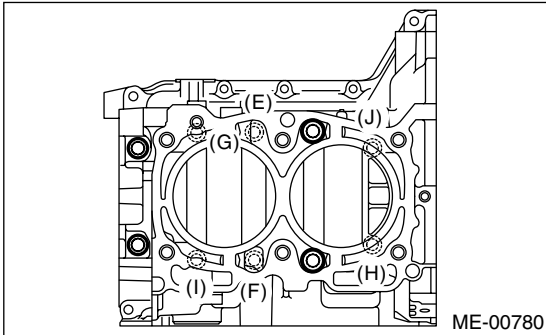

7) Further tighten the LH side bolts (A — D) in alphabetical sequence.

Tightening torque:

(A), (C): 20 N·m (2.0 kgf·m, 14.8 ft-lb)

(B), (D): 15 N·m (1.5 kgf·m, 10.8 ft-lb)

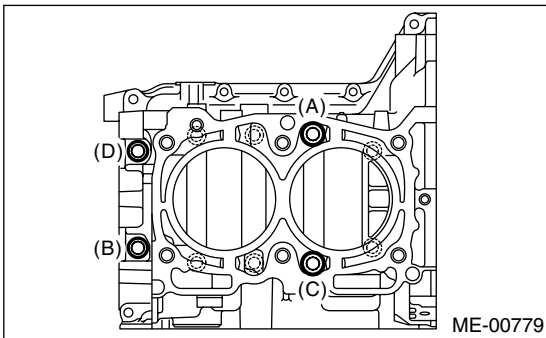

8) Further tighten the RH side bolts (E — J) in alphabetical sequence.

Tightening torque:

(E), (F), (G), (I): 20 N·m (2.0 kgf·m, 14.8 ft-lb)

(H), (J): 18 N·m (1.8 kgf·m, 13.3 ft-lb)

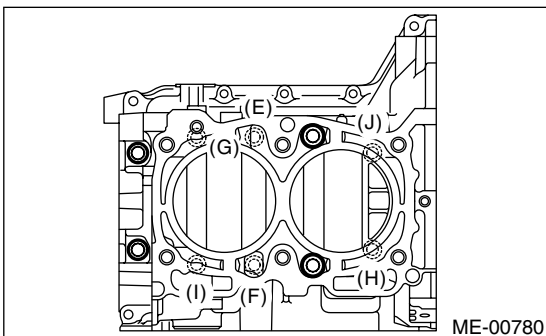

9) Further tighten the LH side bolts (A — D) by 90° in alphabetical sequence.

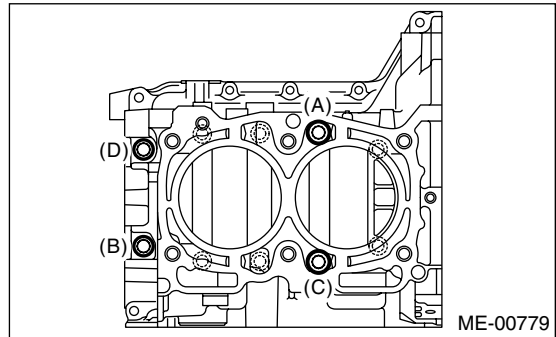

10) Further tighten the RH side bolts (E — J) by 90° in alphabetical sequence.

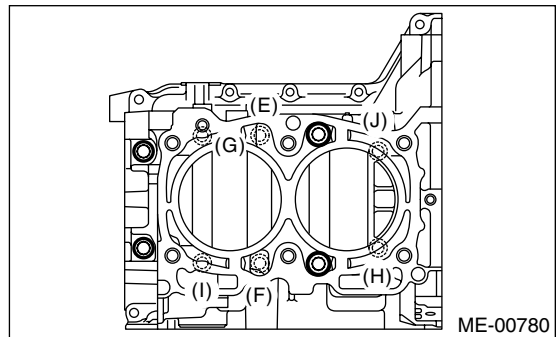

11) Tighten the 8 mm and 6 mm cylinder block connecting bolts in alphabetical sequence shown in the figure.

Tightening torque:

(A) — (G): 25 N·m (2.5 kgf·m, 18.1 ft-lb)

(H): 6.4 N·m (0.65 kgf·m, 4.7 ft-lb)

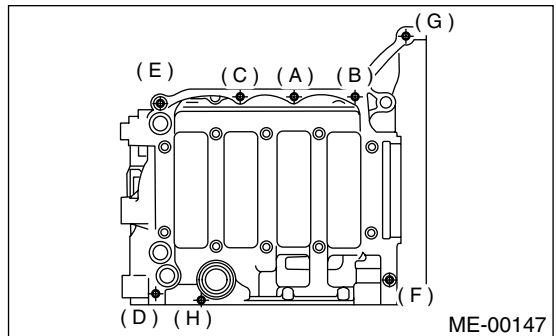

CYLINDER BLOCK

MECHANICAL

12) Install the rear oil seal using ST1 and ST2.

ST1 499597100 CRANKSHAFT OIL SEAL GUIDE

ST2 499587200 CRANKSHAFT OIL SEAL INSTALLER

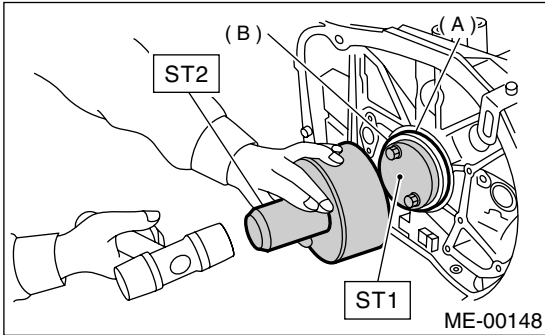

- (A) Rear oil seal
- (B) Flywheel attaching bolt

13) Position the top ring gap at (A) or (B) in the figure.

14) Position the second ring gap at 180° on the reverse side for the top ring gap.

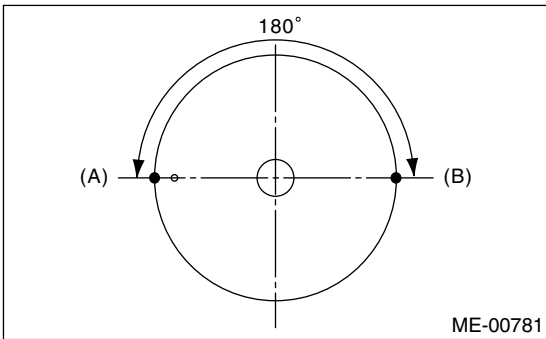

15) Position the upper rail gap at (C) in the figure.

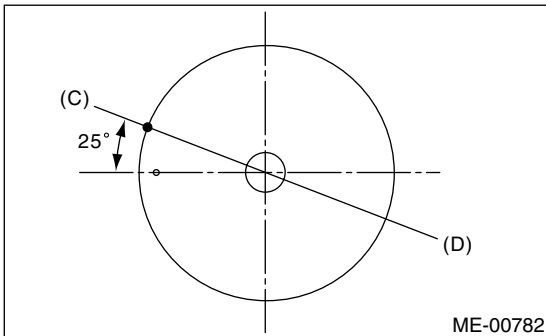

16) Align upper rail spin stopper (D) with piston side surface hole (E).

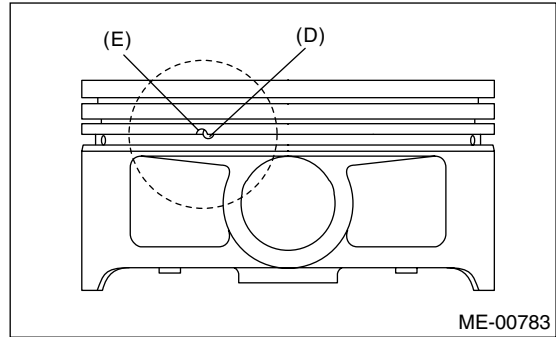

17) Position the expander gap at (F) in the figure.

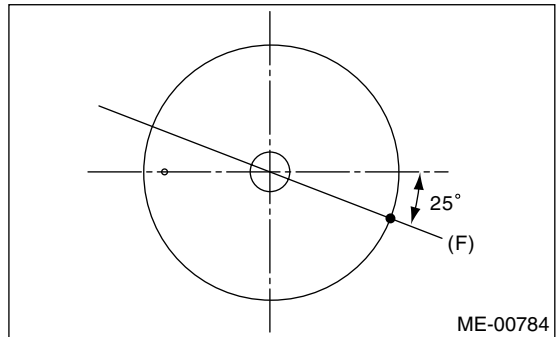

18) Position the lower rail gap at (G) in the figure.

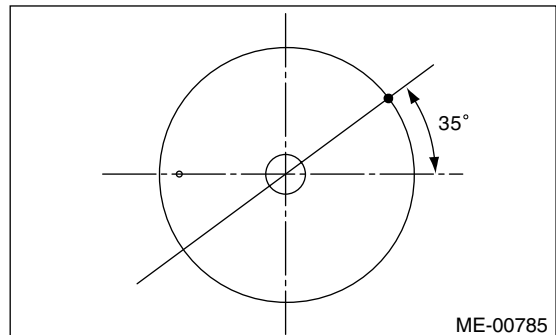

NOTE:

- Ensure ring gaps do not face the same direction.
- Ensure ring gaps are not within the piston skirt area.

CYLINDER BLOCK

MECHANICAL

19) Install the circlip.
Install the circlips in piston holes located opposite of service holes in cylinder block, when positioning all pistons in the corresponding cylinders.

NOTE:
Use new circlips.

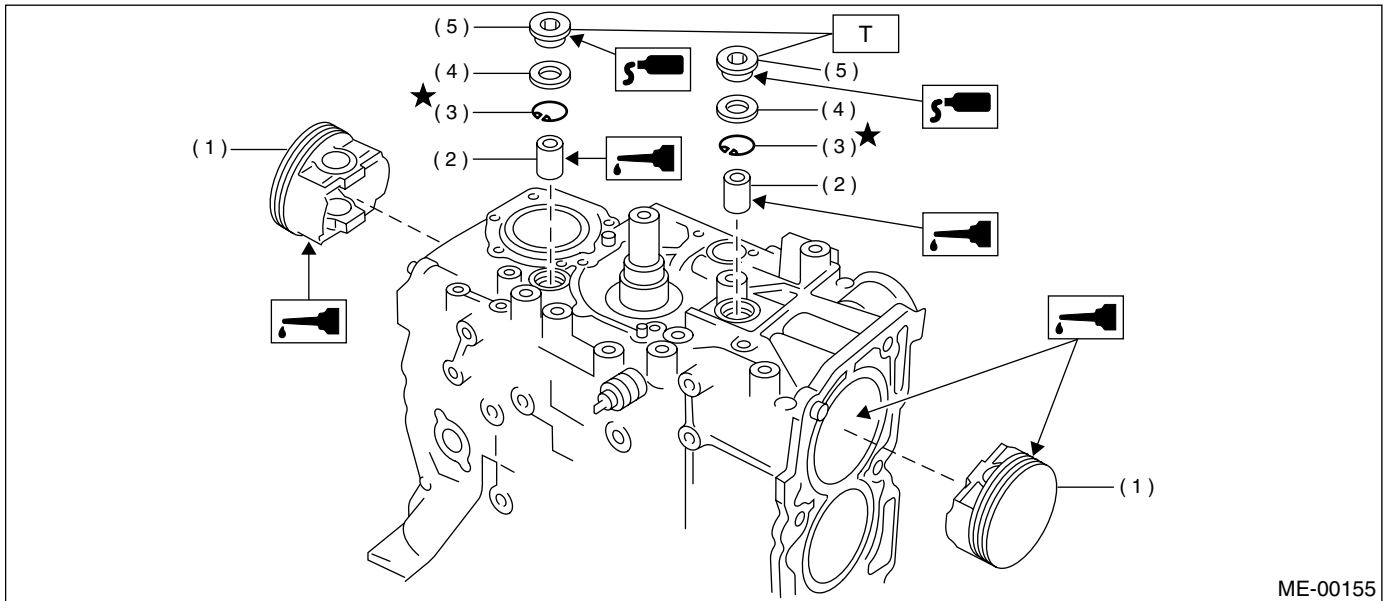
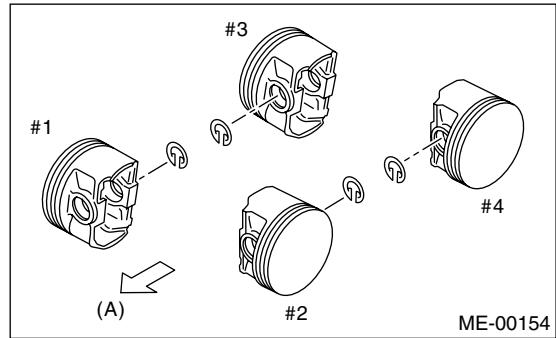

- (1) Piston
- (2) Piston pin
- (3) Circlip
- (4) Gasket
- (5) Service hole plug

Tightening torque: N·m (kgf·m, ft·lb)
T: 70 (7.1, 51.4)

20) Installing the piston:
(1) Turn the cylinder block so that #1 and #2 cylinders face upward.
(2) Using the ST1, turn the crankshaft so that #1 and #2 connecting rods are set at bottom dead center.

ST1 499987500 CRANKSHAFT SOCKET
(3) Apply a coat of engine oil to the pistons and cylinders and insert pistons in their cylinders using ST2.

ST2 498747300 PISTON GUIDE

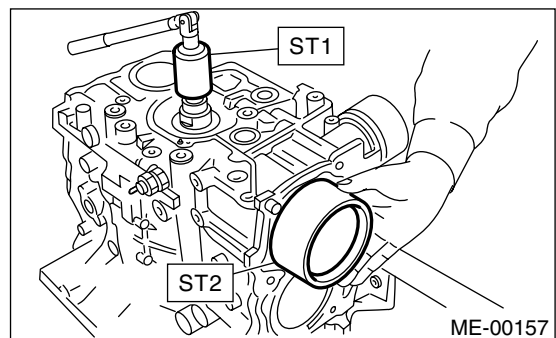

CYLINDER BLOCK

MECHANICAL

NOTE:

Piston front mark faces towards the front of the engine.

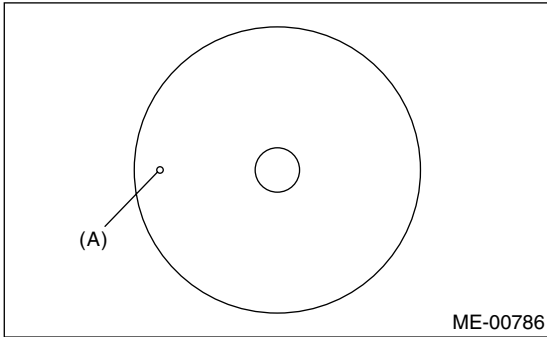

(A) Front mark

21) Installing piston pin:

- (1) Apply a coat of engine oil to ST3, and then insert the ST3 into service hole to align piston pin hole with connecting rod small end.

ST3 499017100 PISTON PIN GUIDE

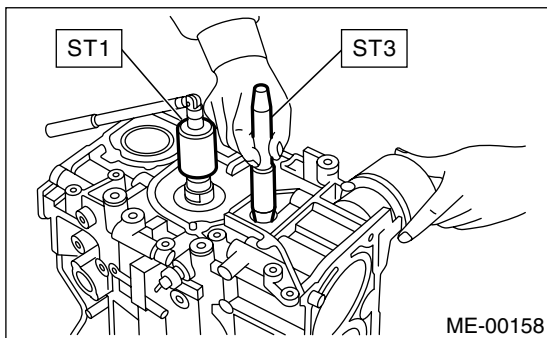

- (2) Apply a coat of engine oil to the piston pin and insert piston pin into piston and connecting rod through service hole.
- (3) Using the ST, install the circlip.

NOTE:

Use new circlips.

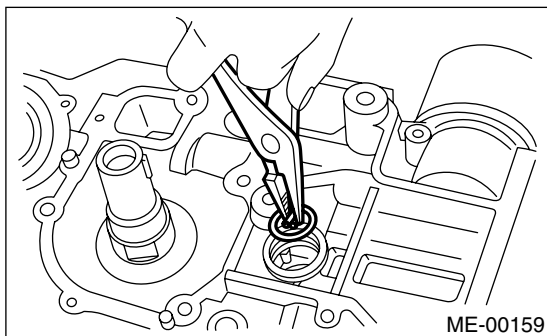

CYLINDER BLOCK

MECHANICAL

(4) Apply fluid packing around the service hole plug.

(5) Install the service hole plug and gasket.

Fluid packing:

Part No. 004403007

THREE BOND 1215 or equivalent

NOTE:

Use a new gasket.

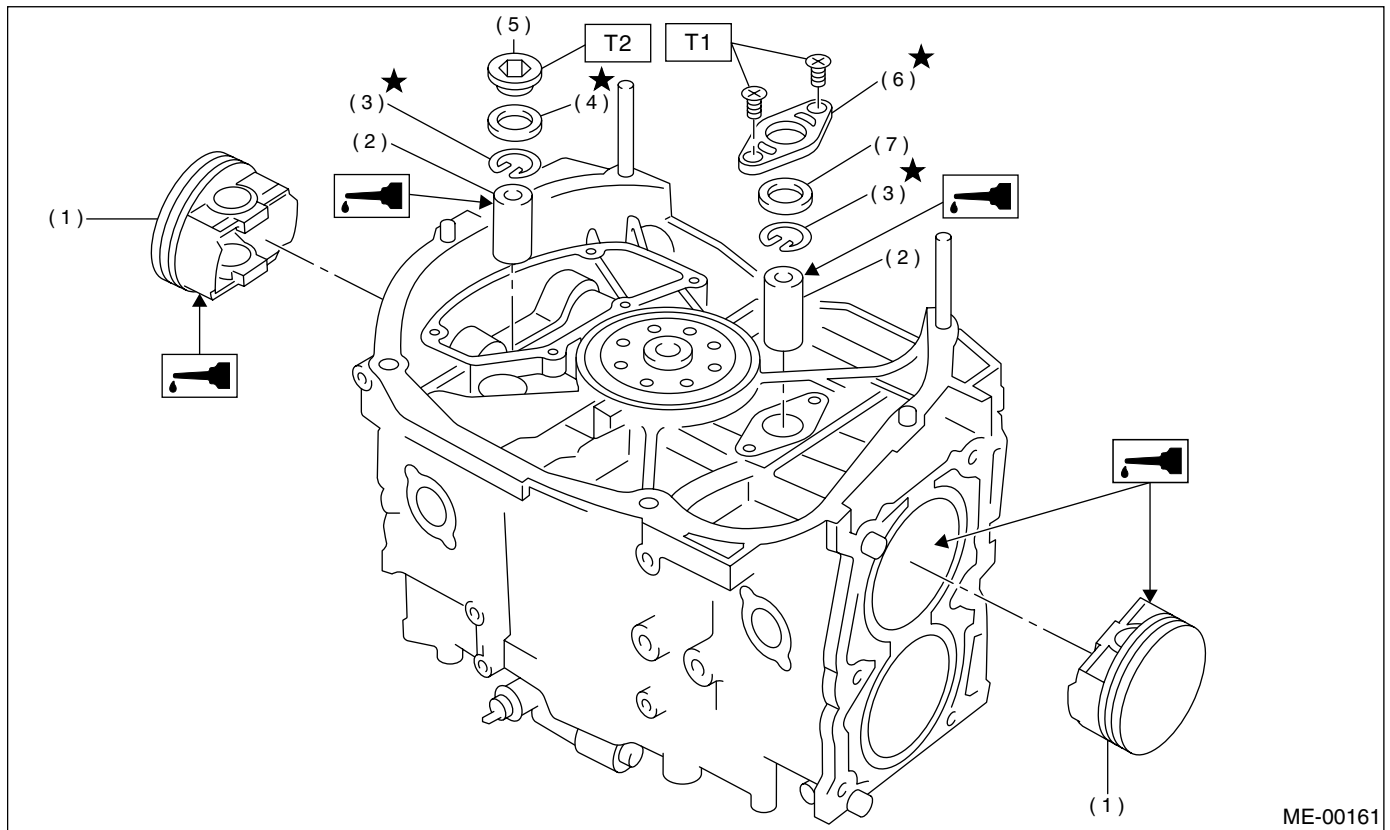
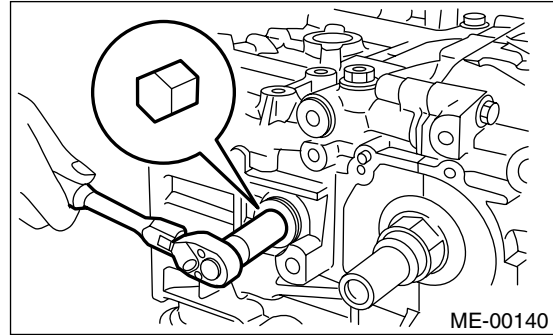
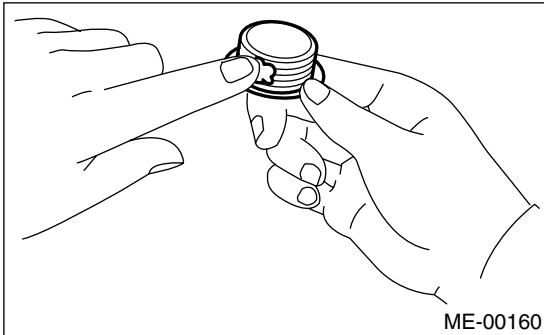

- (1) Piston
- (2) Piston pin
- (3) Circlip
- (4) Gasket
- (5) Service hole plug
- (6) Service hole cover
- (7) O-ring

Tightening torque: N·m (kgf-m, ft-lb)

T1: 6.4 (0.65, 4.7)

T2: 70 (7.1, 51.4)

(6) Turn the cylinder block so that #3 and #4 cylinders face upward. Using the same procedures as used for #1 and #2 cylinders, install the pistons and piston pins.

24) Install the oil strainer and O-ring

Tightening torque:
10 N·m (1.0 kgf-m, 7 ft-lb)

22) Install the water pipe.

23) Install the baffle plate.

25) Install the oil strainer stay.

Tightening torque:

6.4 N·m (0.65 kgf-m, 4.7 ft-lb)

CYLINDER BLOCK

MECHANICAL

26) Apply fluid packing to the matching surfaces, and then install the oil pan.

Fluid packing:

Part No. 004403012

THREE BOND 1207C or equivalent

Tightening torque:

5 N·m (0.5 kgf-m, 3.6 ft-lb)

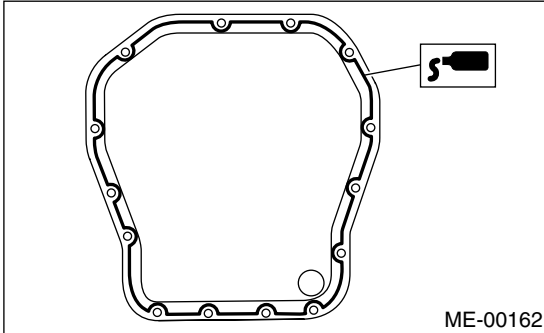

27) Apply fluid packing to the matching surfaces, and then install the oil separator cover.

Fluid packing:

Part No. 004403007

THREE BOND 1215 or equivalent

Tightening torque:

6.4 N·m (0.65 kgf-m, 4.7 ft-lb)

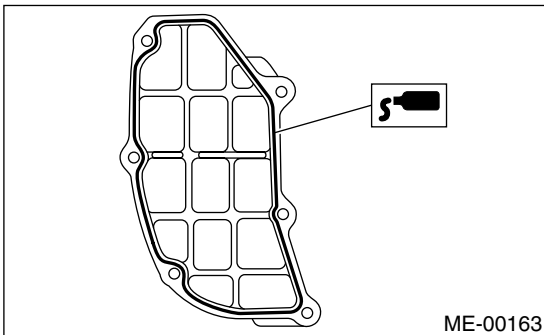

28) Install the flywheel. <Ref. to CL-11, INSTALLATION, Clutch Disc and Cover.>

29) Install the clutch disc and cover. <Ref. to CL-11, REMOVAL, Clutch Disc and Cover.>

30) Installation of oil pump:

(1) Discard the front oil seal after removal. Replace with a new one using the ST.

ST 499587100

OIL SEAL INSTALLER

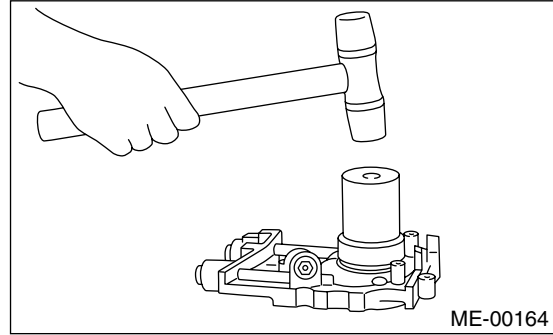

(2) Apply fluid packing to the matching surface of oil pump.

Fluid packing:

Part No. 004403007

THREE BOND 1215 or equivalent

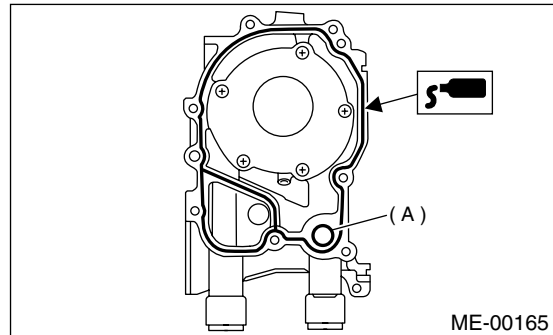

(A) O-ring

(3) Apply a coat of engine oil to the inside of the oil seal.

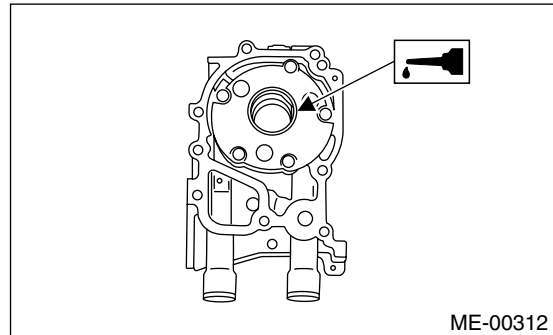

(4) Install the oil pump on cylinder block. Be careful not to damage the oil seal during installation.

Tightening torque:

6.4 N·m (0.65 kgf-m, 4.7 ft-lb)

NOTE:

- Do not forget to install the O-ring and seal when installing the oil pump.
- Align the flat surface of oil pump's inner rotor with crankshaft before installation.

31) Install the water pump and gasket.

Tightening torque:

First; 12 N·m (1.2 kgf-m, 8.7 ft-lb)

Second; 12 N·m (1.2 kgf-m, 8.7 ft-lb)

NOTE:

- Be sure to use a new gasket.
- When installing the water pump, tighten the bolts in two stages in alphabetical sequence as shown in the figure.

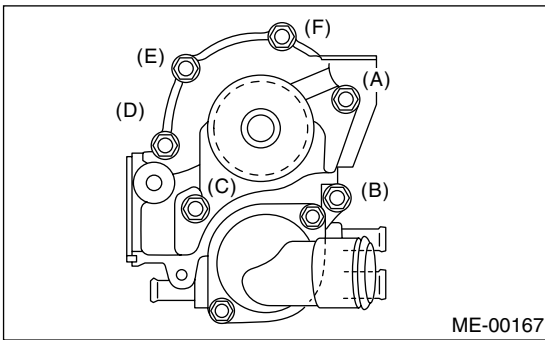

32) Install the water by-pass pipe for heater.

33) Install the oil cooler.

Tightening torque:

T1: 45 N·m (4.6 kgf-m, 33 ft-lb)

T2: 6.4 N·m (0.65 kgf-m, 4.7 ft-lb)

T3: 54 N·m (5.3 kgf-m, 39 ft-lb)

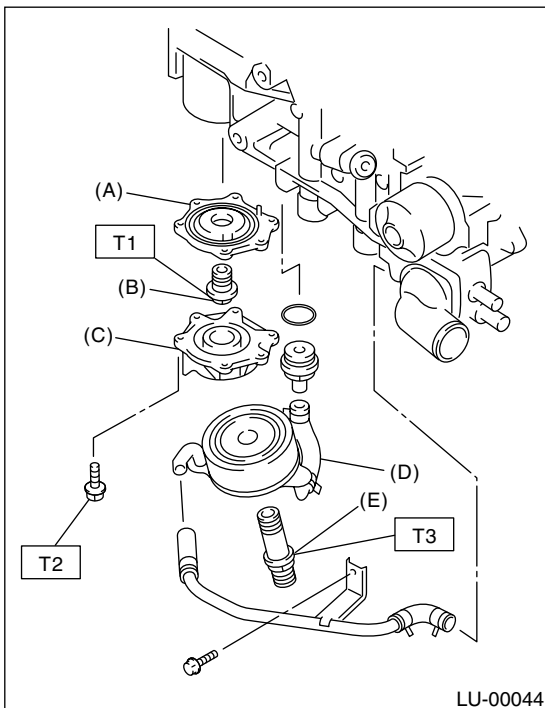

- (A) Adapter (1)
- (B) Adapter connector
- (C) Adapter (2)
- (D) Oil cooler
- (E) Oil cooler connector

34) Install the oil filter using ST.

ST 18332AA000 OIL FILTER WRENCH (Outer diameter: 68 mm)

ST 18332AA010 OIL FILTER WRENCH (Outer diameter: 65 mm)

35) Install the water by-pass pipe between oil cooler and water pump.

36) Install the water pipe.

NOTE:

Always use a new O-ring.

37) Install the cylinder head assembly. **<Ref. to ME(H4DOTC)-65, INSTALLATION, CYLINDER HEAD ASSEMBLY.>**

38) Install the oil level gauge guide and tighten the attaching bolt (LH side).

39) Install the rocker cover.

40) Install the crankshaft sprocket. **<Ref. to ME(H4DOTC)-58, INSTALLATION, CRANKSHAFT SPROCKET.>**

41) Install the camshaft sprocket. <Ref. to ME(H4DOTC)-57, INSTALLATION, Camshaft Sprocket.>

42) Install the timing belt assembly. <Ref. to ME(H4DOTC)-51, INSTALLATION, Timing Belt Assembly.>

43) Install the timing belt cover. <Ref. to ME(H4DOTC)-48, INSTALLATION, Timing Belt Cover.>

44) Install the crankshaft pulley. **<Ref. to ME(H4DOTC)-47, INSTALLATION, CRANKSHAFT PULLEY.>**

45) Install the generator and A/C compressor brackets on cylinder head.

46) Install the V-belt. <Ref. to ME(H4DOTC)-45, INSTALLATION, V-belt.>

47) Install the intake manifold. <Ref. to FU(H4DOTC)-17, INSTALLATION, Intake Manifold.>

CYLINDER BLOCK

MECHANICAL

C: DISASSEMBLY

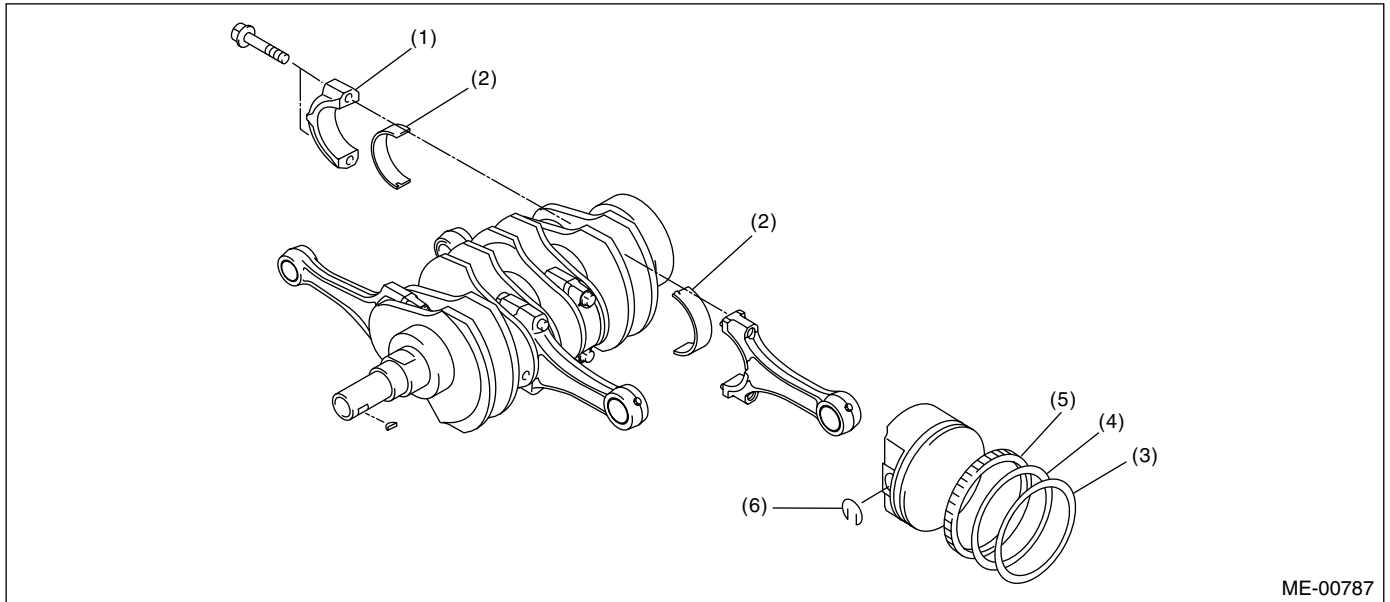

ME-00787

(1) Connecting rod cap

(3) Top ring

(5) Oil ring

(2) Connecting rod bearing

(4) Second ring

(6) Circlip

1) Remove the connecting rod cap.

2) Remove the connecting rod bearing.

NOTE:

Arrange the removed connecting rod, connecting rod cap and bearing in order to prevent confusion.

3) Remove the piston rings using the piston ring expander.

4) Remove the oil ring by hand.

NOTE:

Arrange the removed piston rings in proper order to prevent confusion.

5) Remove the circlip.

D: ASSEMBLY

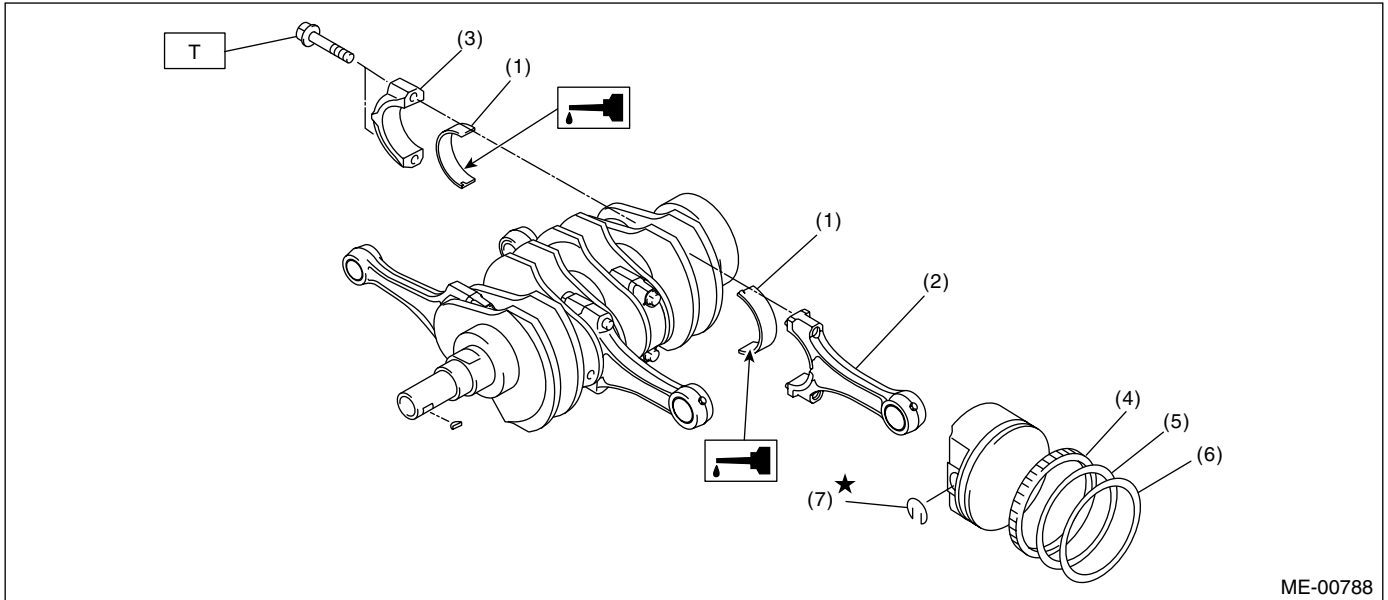

- | | |
|----------------------------|-----------------|
| (1) Connecting rod bearing | (5) Second ring |
| (2) Connecting rod | (6) Top ring |
| (3) Connecting rod cap | (7) Circlip |
| (4) Oil ring | |

Tightening torque: N-m (kgf-m, ft-lb)

T: 52 (5.3, 38.4)

1) Apply oil to the surfaces of the connecting rod bearings. Install the connecting rod bearings on connecting rods and connecting rod caps.

2) Install the connecting rod on crankshaft.

NOTE:

Position each connecting rod with the side marked facing forward.

3) Install the connecting rod cap with connecting rod nut.

Ensure the arrow on connecting rod cap faces the front during installation.

NOTE:

- Each connecting rod has its own mating cap. Make sure that they are assembled correctly by checking their matching number.

- When tightening the connecting rod nuts, apply oil on the threads.

4) Install the oil ring spacer, upper rail and lower rail in this order by hand. Then install the second ring and top ring with a piston ring expander.

E: INSPECTION

1. CYLINDER BLOCK

1) Visually check for cracks and damage. Especially, inspect the important parts by means of red lead check.

2) Check the oil passages for clogging.

3) Inspect the crankcase surface that mates with cylinder head for warping by using a straight edge, and correct by grinding if necessary.

Warping limit:

0.05 mm (0.0020 in)

Grinding limit:

0.1 mm (0.004 in)

Standard height of cylinder block:

201.0 mm (7.91 in)

CYLINDER BLOCK

MECHANICAL

2. CYLINDER AND PISTON

1) The cylinder bore size is stamped on cylinder block's front upper surface.

NOTE:

Measurement should be performed at a temperature of 20°C (68°F).

NOTE:

Standard sized pistons are classified into two grades, "A" and "B". These grades should be used as a guide line in selecting a standard piston.

Standard diameter:

A: 99.505 — 99.515 mm (3.9175 — 3.9179 in)

B: 99.495 — 99.505 mm (3.9171 — 3.9175 in)

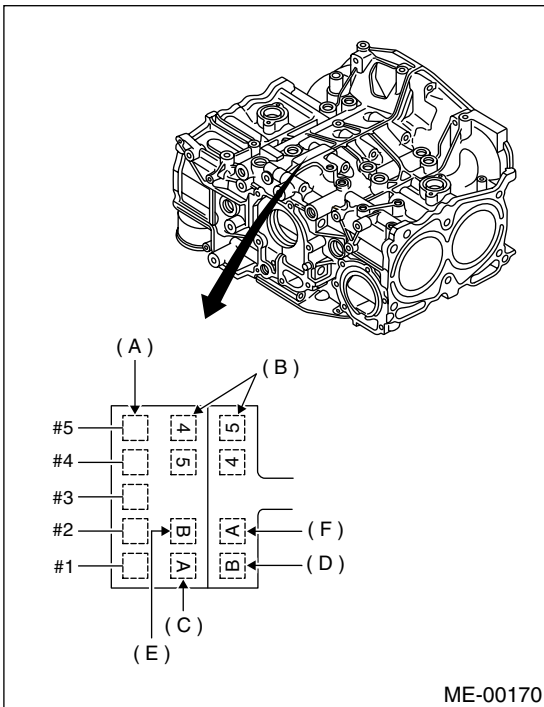

- (A) Main journal size mark
- (B) Cylinder block (RH)-(LH) combination mark
- (C) #1 cylinder bore size mark
- (D) #2 cylinder bore size mark
- (E) #3 cylinder bore size mark
- (F) #4 cylinder bore size mark

2) How to measure the inner diameter of each cylinder:

Measure the inner diameter of each cylinder in both the thrust and piston pin directions at the heights shown in the figure, using a cylinder bore gauge.

NOTE:

Measurement should be performed at a temperature of 20°C (68°F).

Taper:

Standard

0.015 mm (0.0006 in)

Limit

0.050 mm (0.0020 in)

Out-of-roundness:

Standard

0.010 mm (0.0004 in)

Limit

0.050 mm (0.0020 in)

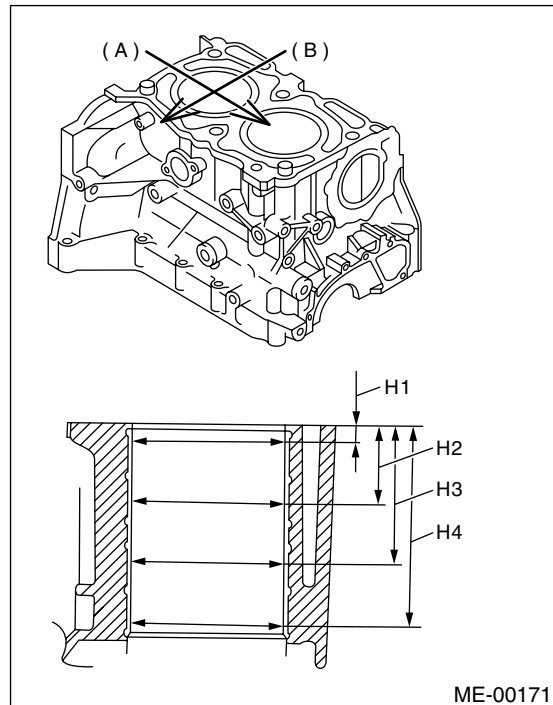

- (A) Piston pin direction
- (B) Thrust direction
- H1: 10 mm (0.39 in)
- H2: 45 mm (1.77 in)
- H3: 80 mm (3.15 in)
- H4: 115 mm (4.53 in)

3) When the piston is to be replaced due to general or cylinder wear, determine a suitable sized piston by measuring the piston clearance.

4) How to measure the outer diameter of each piston:

Measure the outer diameter of each piston at the height shown in the figure. (Thrust direction)

NOTE:

Measurement should be performed at a temperature of 20°C (68°F).

Piston grade point H:

38.2 mm (1.50 in)

Piston outer diameter:

Standard

A: 99.505 — 99.515 mm

(3.9175 — 3.9179 in)

B: 99.495 — 99.505 mm

(3.9171 — 3.9175 in)

0.25 mm (0.0098 in) oversize

99.745 — 99.765 mm

(3.9270 — 3.9278 in)

0.50 mm (0.0197 in) oversize

99.995 — 100.015 mm

(3.9368 — 3.9376 in)

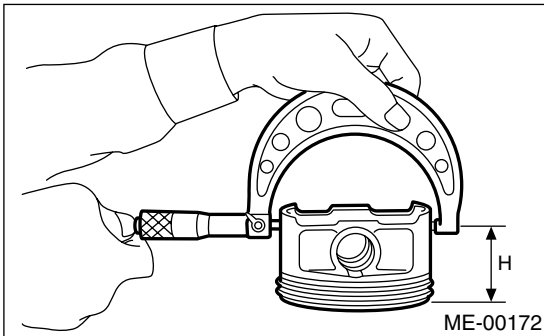

5) Calculate the clearance between cylinder and piston.

NOTE:

Measurement should be performed at a temperature of 20°C (68°F).

Cylinder to piston clearance at 20°C (68°F):

Standard

-0.010 — 0.010 mm (-0.0004 — 0.0004 in)

Limit

0.030 mm (0.0012 in)

6) Boring and honing:

(1) If the value of taper, out-of-roundness, or cylinder-to-piston clearance measured exceeds the specified limit or if there is any damage on the cylinder wall, reboring it to use an oversize piston.

CAUTION:

When any of the cylinders needs reboring, all other cylinders must be bored at the same time, and use oversize pistons. Do not perform boring on one cylinder only, nor use an oversize piston for one cylinder only.

(2) If the cylinder inner diameter exceeds the limit after boring and honing, replace the crankcase.

NOTE:

Immediately after reboring, the cylinder diameter may differ from its real diameter due to temperature rise. Thus, pay attention to this when measuring the cylinder diameter.

Limit of cylinder enlarging (boring):

0.5 mm (0.020 in)

3. PISTON AND PISTON PIN

1) Check the pistons and piston pins for damage, cracks, and wear and the piston ring grooves for wear and damage. Replace if defective.

2) Measure the piston-to-cylinder clearance at each cylinder. <Ref. to ME(H4DOTC)-86, CYLINDER AND PISTON.> If any of the clearances is not within specification, replace the piston or bore the cylinder to use an oversize piston.

CYLINDER BLOCK

MECHANICAL

3) Make sure that the piston pin can be inserted into the piston pin hole with a thumb at 20°C (68°F). Replace if defective.

Standard clearance between piston pin and hole in piston:

Standard

0.004 — 0.008 mm (0.0002 — 0.0003 in)

Limit

0.020 mm (0.0008 in)

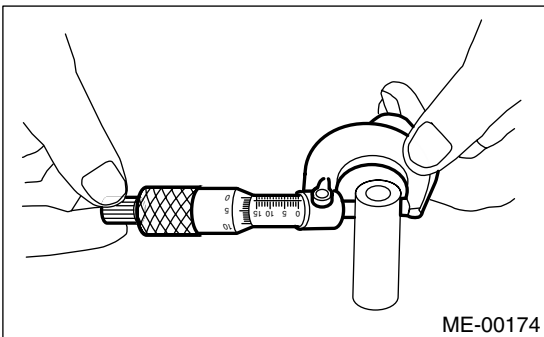
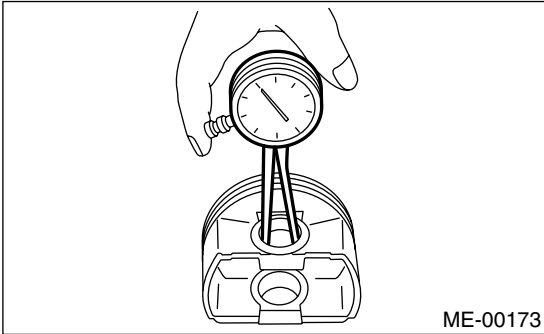

4) Check the circlip installation groove on piston for burr (A). If necessary, remove the burr from groove so that the piston pin can lightly move.

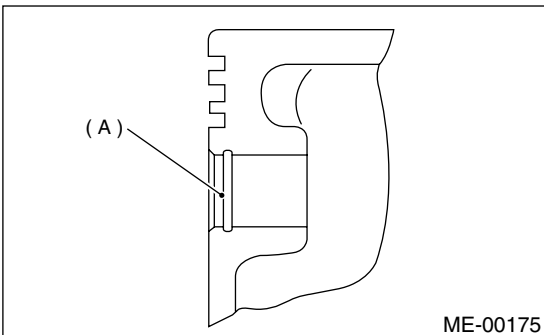

5) Check the piston pin circlip for distortion, cracks and wear.

4. PISTON RING

1) If the piston ring is broken, damaged, or worn, or if its tension is insufficient, or when the piston is replaced, replace the piston ring with a new one of the same size as the piston.

NOTE:

- Marks are shown on the end of top and second rings. When installing the rings to piston, face this mark upward.
- Oil ring consists of upper rail, expander and lower rail. When installing on piston, be careful of each rail's direction.

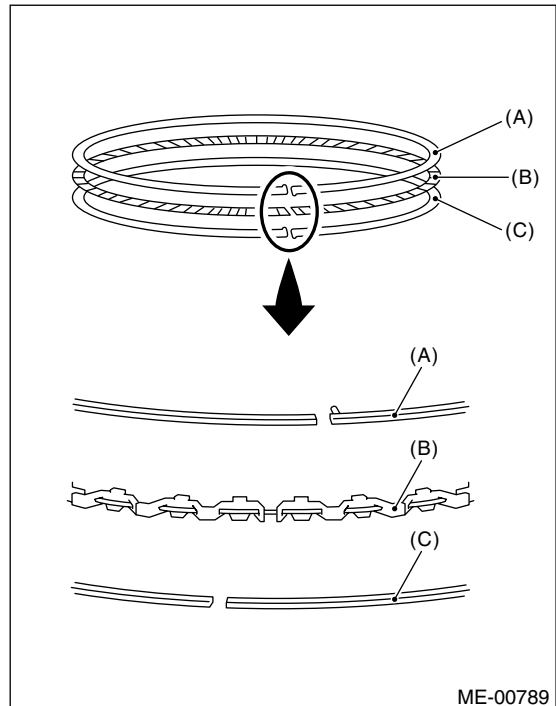

- (A) Upper rail
- (B) Expander
- (C) Lower rail

2) Squarely place the piston ring and oil ring in cylinder, and then measure the piston ring gap with a thickness gauge.

		Unit: mm (in)	
		Standard	Limit
Piston ring gap	Top ring	0.20 — 0.25 (0.0079 — 0.0098)	1.0 (0.039)
	Second ring	0.37 — 0.52 (0.015 — 0.020)	1.0 (0.039)
	Oil ring rail	0.20 — 0.50 (0.0079 — 0.0197)	1.5 (0.059)

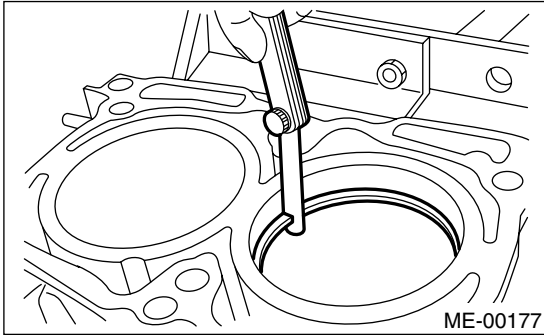

3) Measure the clearance between piston ring and piston ring groove with a thickness gauge.

NOTE:

Before measuring the clearance, clean the piston ring groove and piston ring.

		Unit: mm (in)	
		Standard	Limit
Clearance between piston ring and piston ring groove	Top ring	0.040 — 0.080 (0.0016 — 0.0031)	0.15 (0.0059)
	Second ring	0.030 — 0.070 (0.0012 — 0.0028)	0.15 (0.0059)

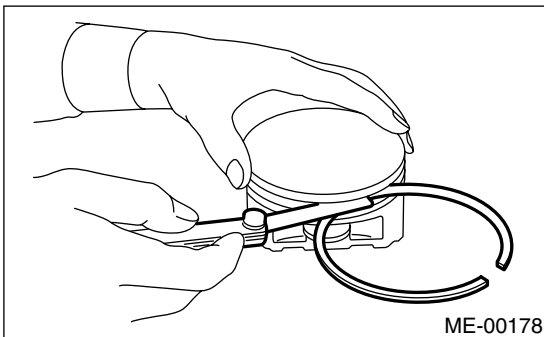

5. CONNECTING ROD

- 1) Replace the connecting rod, if the large or small end thrust surface is damaged.
- 2) Check for bend or twist using a connecting rod aligner. Replace the connecting rod if the bend or twist exceeds the limit.

Limit of bend or twist per 100 mm (3.94 in) in length:

0.10 mm (0.0039 in)

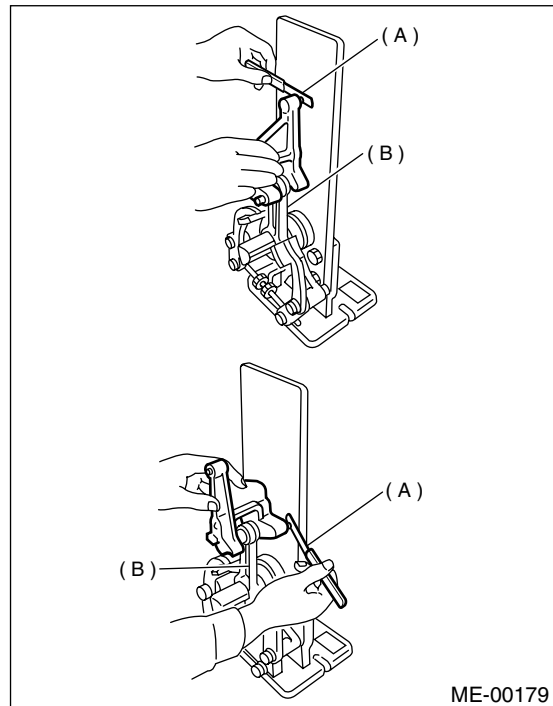

- (A) Thickness gauge
- (B) Connecting rod

3) Install the connecting rod fitted with bearing to crankshaft, and then measure the side clearance (thrust clearance). Replace the connecting rod if the side clearance exceeds the specified limit.

Connecting rod side clearance:

Standard

0.070 — 0.330 mm (0.0028 — 0.0130 in)

Limit

0.40 mm (0.016 in)

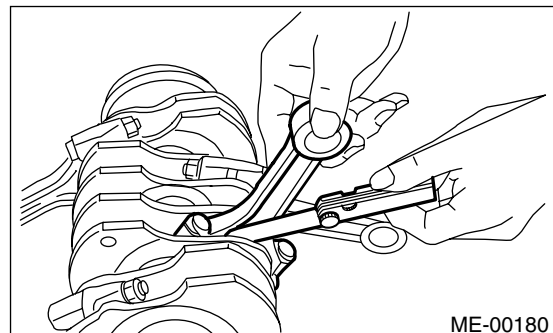

CYLINDER BLOCK

MECHANICAL

4) Inspect the connecting rod bearing for scar, peeling, seizure, melting, wear, etc.

5) Measure the oil clearance on individual connecting rod bearings by means of plastigauge. If any oil clearance is not within specification, replace the defective bearing with a new one of standard size or undersize as necessary. (See the table below.)

Connecting rod oil clearance:

Standard

0.017 — 0.045 mm (0.0007 — 0.0018 in)

Limit

0.050 mm (0.0020 in)

Unit: mm (in)		
Bearing	Bearing size (Thickness at center)	Outer diameter of crank pin
Standard	1.490 — 1.502 (0.0587 — 0.0591)	51.984 — 52.000 (2.0466 — 2.0472)
0.03 (0.0012) undersize	1.504 — 1.512 (0.0592 — 0.0595)	51.954 — 51.970 (2.0454 — 2.0461)
0.05 (0.0020) undersize	1.514 — 1.522 (0.0596 — 0.0599)	51.934 — 51.950 (2.0447 — 2.0453)
0.25 (0.0098) undersize	1.614 — 1.622 (0.0635 — 0.0639)	51.734 — 51.750 (2.0368 — 2.0374)

6) Inspect the bushing at connecting rod small end, and replace if worn or damaged. Also measure the piston pin clearance at connecting rod small end.

Clearance between piston pin and bushing:

Standard

0 — 0.022 mm (0 — 0.0009 in)

Limit

0.030 mm (0.0012 in)

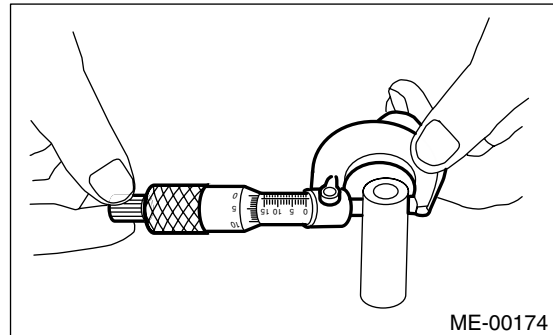
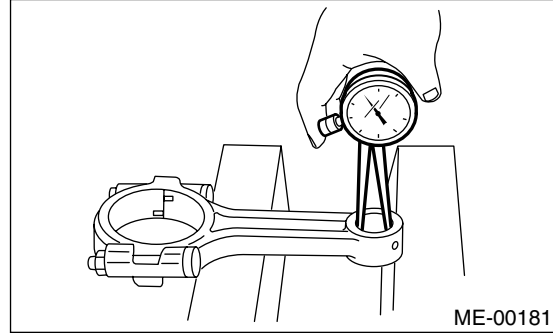

7) Replacement procedure is as follows:

- (1) Remove the bushing from connecting rod with ST and press.
- (2) Press the bushing with ST after applying oil on the periphery of bushing.

ST 499037100 CONNECTING ROD BUSHING REMOVER AND INSTALLER

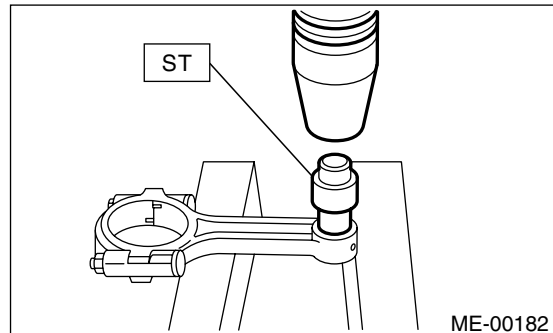

- (3) Make two 3 mm (0.12 in) holes in bushing. Ream the inside of bushing.
- (4) After the completion of reaming, clean the bushing to remove chips.

6. CRANKSHAFT AND CRANKSHAFT BEARING

- 1) Clean the crankshaft completely and check for cracks by means of red lead check etc., and replace if defective.
- 2) Measure the crankshaft bend, and correct or replace if it exceeds the limit.

NOTE:

If a suitable V-block is not available, install the #1 and #5 crankshaft bearing on cylinder block, position the crankshaft on these bearings and measure the crankshaft bend using a dial gauge.

Crankshaft bend limit:
0.035 mm (0.0014 in)

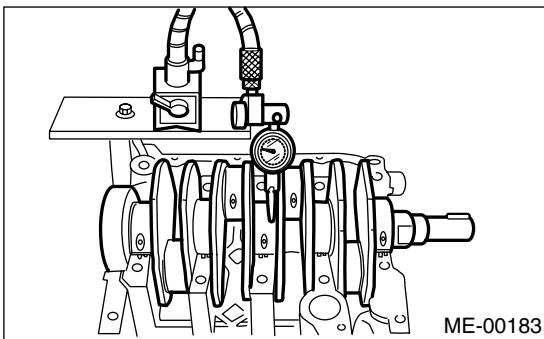

- 3) Inspect the crank journal and crank pin for wear. If they are not within the specifications, replace the bearing with a suitable (undersize) one, and then replace or recondition the crankshaft as necessary. When grinding the crank journal or crank pin, finish them to specified dimensions according to the undersize bearing to be used.

Crank pin and crank journal:

Out-of-roundness

0.005 mm (0.0002 in) or less

Taper limit

0.07 mm (0.0028 in)

Grinding limit

0.250 mm (0.0098 in)

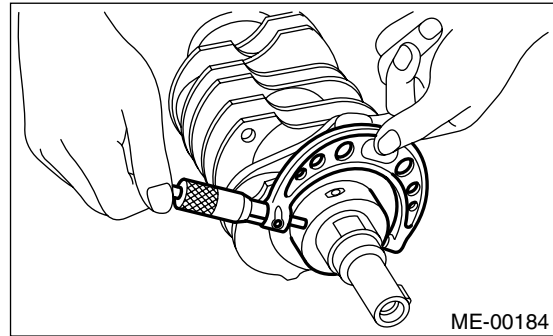

		Unit: mm (in)		
		Crank journal diameter		Crank pin outer diameter
		#1, #3, #5	#2, #4	
Standard	Journal O.D.	59.992 — 60.008 (2.3619 — 2.3625)	59.992 — 60.008 (2.3619 — 2.3625)	51.984 — 52.000 (2.0466 — 2.0472)
	Bearing size (Thickness at center)	1.998 — 2.011 (0.0787 — 0.0792)	2.000 — 2.013 (0.0787 — 0.0793)	1.486 — 1.498 (0.0585 — 0.0590)
0.03 (0.0012) undersize	Journal O.D.	59.962 — 59.978 (2.3607 — 2.3613)	59.962 — 59.978 (2.3607 — 2.3613)	51.954 — 51.970 (2.0454 — 2.0461)
	Bearing size (Thickness at center)	2.017 — 2.020 (0.0794 — 0.0795)	2.019 — 2.022 (0.0795 — 0.0796)	1.504 — 1.512 (0.0592 — 0.0595)
0.05 (0.0020) undersize	Journal O.D.	59.942 — 59.958 (2.3599 — 2.3605)	59.942 — 59.958 (2.3599 — 2.3605)	51.934 — 51.950 (2.0447 — 2.0453)
	Bearing size (Thickness at center)	2.027 — 2.030 (0.0798 — 0.0799)	2.029 — 2.032 (0.0799 — 0.0800)	1.514 — 1.522 (0.0596 — 0.0599)
0.25 (0.0098) undersize	Journal O.D.	59.742 — 59.758 (2.3520 — 2.3527)	59.742 — 59.758 (2.3520 — 2.3527)	51.734 — 51.750 (2.0368 — 2.0374)
	Bearing size (Thickness at center)	2.127 — 2.130 (0.0837 — 0.0839)	2.129 — 2.132 (0.0838 — 0.0839)	1.614 — 1.622 (0.0635 — 0.0639)

O.D.: Outer Diameter

CYLINDER BLOCK

MECHANICAL

4) Measure the thrust clearance of crankshaft at center bearing. If the clearance exceeds the limit, replace the bearing.

Crankshaft side clearance:

Standard

0.030 — 0.115 mm (0.0012 — 0.0045 in)

Limit

0.25 mm (0.0098 in)

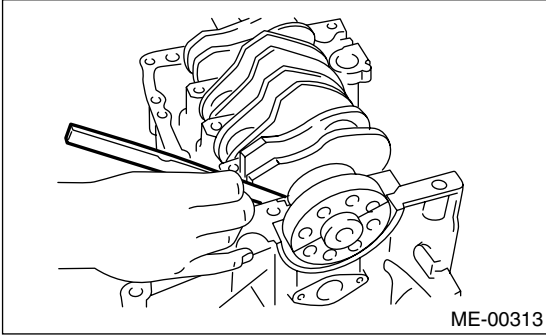

5) Inspect individual crankshaft bearings for signs of flaking, seizure, melting, and wear.

6) Measure the oil clearance on each crankshaft bearing by means of plastigauge. If the measurement is not within the specification, replace the defective bearing with an undersize one, and replace or recondition the crankshaft as necessary.

Unit: mm (in)		
Crankshaft oil clearance		
#1	STD	0.003 — 0.030 (0.00012 — 0.0012)
	Limit	0.040 (0.0016)
#2	STD	0.012 — 0.033 (0.0004 — 0.0012)
	Limit	0.045 (0.0018)
#3	STD	0.003 — 0.033 (0.00012 — 0.0012)
	Limit	0.040 (0.0016)
#4	STD	0.012 — 0.033 (0.0004 — 0.0012)
	Limit	0.045 (0.0018)
#5	STD	0.010 — 0.031 (0.0004 — 0.0012)
	Limit	0.040 (0.0016)

21. Intake and Exhaust Valve

A: SPECIFICATIONS

For operations related to intake and exhaust valve, refer to "19. Cylinder Head." <Ref. to ME(H4DOTC)-65, REMOVAL, Cylinder Head Assembly.> and <Ref. to ME(H4DOTC)-65, REMOVAL, Cylinder Head Assembly.>

22.Piston

A: SPECIFICATIONS

For operations related to piston, refer to “20. Cylinder Block.” <Ref. to ME(H4DOTC)-72, REMOVAL, Cylinder Block.> and <Ref. to ME(H4DOTC)-72, REMOVAL, Cylinder Block.>

23.Connecting Rod

A: SPECIFICATIONS

For operations related to connecting rod, refer to "20. Cylinder Block." <Ref. to ME(H4DOTC)-72, REMOVAL, Cylinder Block.> and <Ref. to ME(H4DOTC)-72, REMOVAL, Cylinder Block.>

24.Crankshaft

A: SPECIFICATIONS

For operations related to crankshaft, refer to “20. Cylinder Block.” <Ref. to ME(H4DOTC)-96, SPECIFICATIONS, Crankshaft.> and <Ref. to ME(H4DOTC)-72, REMOVAL, Cylinder Block.>

ENGINE TROUBLE IN GENERAL

MECHANICAL

25.Engine Trouble in General

A: INSPECTION

NOTE:

“RANK” shown in the chart refers to the possibility of reason for the trouble in order (“Very often” to “Rarely”)

A — Very often
 B — Sometimes
 C — Rarely

TROUBLE	PROBLEM PARTS, ETC.	POSSIBLE CAUSE	RANK
1. Engine will not start.			
1) Starter does not turn.	Starter	Defective battery-to-starter harness	B
		Defective starter switch	C
		Defective inhibitor switch or neutral switch	C
		Defective starter	B
	Battery	Poor terminal connection	A
		Run-down battery	A
		Defective charging system	B
	Friction	Seizure of crankshaft and connecting rod bearing	C
		Seized camshaft	C
		Seized or stuck piston and cylinder	C
2) Initial combustion does not occur.	Starter	Defective starter	C
	Engine control system <Ref. to EN(H4DOTC)-2, Basic Diagnostic Procedure.>		A
	Fuel line	Defective fuel pump and relay	A
		Lack of or insufficient fuel	B
	Belt	Defective	B
		Defective timing	B
	Compression	Incorrect valve clearance	C
		Loosened spark plugs or defective gasket	C
		Loosened cylinder head bolts or defective gasket	C
		Improper valve seating	C
		Defective valve stem	C
		Worn or broken valve spring	B
		Worn or stuck piston rings, cylinder and piston	C
		Incorrect valve timing	B
		Improper engine oil (low viscosity)	B
	3) Initial combustion occurs.	Engine control system <Ref. to EN(H4DOTC)-2, Basic Diagnostic Procedure.>	
Intake system		Defective intake manifold gasket	B
		Defective throttle body gasket	B
Fuel line		Defective fuel pump and relay	C
		Clogged fuel line	C
		Lack of or insufficient fuel	B
Belt		Defective	B
		Defective timing	B
Compression		Incorrect valve clearance	C
		Loosened spark plugs or defective gasket	C
		Loosened cylinder head bolts or defective gasket	C
		Improper valve seating	C
		Defective valve stem	C
		Worn or broken valve spring	B
		Worn or stuck piston rings, cylinder and piston	C
		Incorrect valve timing	B
		Improper engine oil (low viscosity)	B

ENGINE TROUBLE IN GENERAL

MECHANICAL

TROUBLE	PROBLEM PARTS, ETC.	POSSIBLE CAUSE	RANK
4) Engine stalls after initial combustion.	Engine control system <Ref. to EN(H4DOTC)-2, Basic Diagnostic Procedure.>		A
	Intake system	Loosened or cracked intake duct	B
		Loosened or cracked PCV hose	C
		Loosened or cracked vacuum hose	C
		Defective intake manifold gasket	B
		Defective throttle body gasket	B
		Dirty air cleaner element	C
	Fuel line	Clogged fuel line	C
		Lack of or insufficient fuel	B
	Belt	Defective	B
		Defective timing	B
	Compression	Incorrect valve clearance	C
		Loosened spark plugs or defective gasket	C
		Loosened cylinder head bolts or defective gasket	C
		Improper valve seating	C
		Defective valve stem	C
		Worn or broken valve spring	B
		Worn or stuck piston rings, cylinder and piston	C
		Incorrect valve timing	B
Improper engine oil (low viscosity)		B	
2. Rough idle and engine stall	Engine control system <Ref. to EN(H4DOTC)-2, Basic Diagnostic Procedure.>		A
	Intake system	Loosened or cracked intake duct	A
		Loosened or cracked PCV hose	A
		Loosened or cracked vacuum hose	A
		Defective intake manifold gasket	B
		Defective throttle body gasket	B
		Defective PCV valve	C
		Loosened oil filler cap	B
		Dirty air cleaner element	C
	Fuel line	Defective fuel pump and relay	C
		Clogged fuel line	C
		Lack of or insufficient fuel	B
	Belt	Defective timing	C
	Compression	Incorrect valve clearance	B
		Loosened spark plugs or defective gasket	B
		Loosened cylinder head bolts or defective gasket	B
		Improper valve seating	B
		Defective valve stem	C
		Worn or broken valve spring	B
		Worn or stuck piston rings, cylinder and piston	B
		Incorrect valve timing	A
		Improper engine oil (low viscosity)	B
	Lubrication system	Incorrect oil pressure	B
		Defective rocker cover gasket	C
	Cooling system	Overheating	C
	Others	Malfunction of evaporative emission control system	A
		Stuck or damaged throttle valve	B
		Accelerator cable out of adjustment	C

ENGINE TROUBLE IN GENERAL

MECHANICAL

TROUBLE	PROBLEM PARTS, ETC.	POSSIBLE CAUSE	RANK
3. Low output, hesitation and poor acceleration	Engine control system <Ref. to EN(H4DOTC)-2, Basic Diagnostic Procedure.>		A
	Intake system	Loosened or cracked intake duct	A
		Loosened or cracked PCV hose	A
		Loosened or cracked vacuum hose	B
		Defective intake manifold gasket	B
		Defective throttle body gasket	B
		Defective PCV valve	B
		Loosened oil filler cap	B
		Dirty air cleaner element	A
	Fuel line	Defective fuel pump and relay	B
		Clogged fuel line	B
		Lack of or insufficient fuel	C
	Belt	Defective timing	B
	Compression	Incorrect valve clearance	B
		Loosened spark plugs or defective gasket	B
		Loosened cylinder head bolts or defective gasket	B
		Improper valve seating	B
		Defective valve stem	C
		Worn or broken valve spring	B
		Worn or stuck piston rings, cylinder and piston	C
		Incorrect valve timing	A
	Improper engine oil (low viscosity)	B	
	Lubrication system	Incorrect oil pressure	B
Cooling system	Overheating	C	
	Over cooling	C	
Others	Malfunction of evaporative emission control system	A	
4. Surging	Engine control system <Ref. to EN(H4DOTC)-2, Basic Diagnostic Procedure.>		A
	Intake system	Loosened or cracked intake duct	A
		Loosened or cracked PCV hose	A
		Loosened or cracked vacuum hose	A
		Defective intake manifold gasket	B
		Defective throttle body gasket	B
		Defective PCV valve	B
		Loosened oil filler cap	B
		Dirty air cleaner element	B
	Fuel line	Defective fuel pump and relay	B
		Clogged fuel line	B
		Lack of or insufficient fuel	C
	Belt	Defective timing	B
	Compression	Incorrect valve clearance	B
		Loosened spark plugs or defective gasket	C
		Loosened cylinder head bolts or defective gasket	C
		Improper valve seating	C
		Defective valve stem	C
		Worn or broken valve spring	C
		Worn or stuck piston rings, cylinder and piston	C
		Incorrect valve timing	A
	Improper engine oil (low viscosity)	B	
	Cooling system	Overheating	B
Others	Malfunction of evaporative emission control system	C	

ENGINE TROUBLE IN GENERAL

MECHANICAL

TROUBLE	PROBLEM PARTS, ETC.	POSSIBLE CAUSE	RANK
5. Engine does not return to idle.	Engine control system <Ref. to EN(H4DOTC)-2, Basic Diagnostic Procedure.>		A
	Intake system	Loosened or cracked vacuum hose	A
	Others	Stuck or damaged throttle valve	A
		Accelerator cable out of adjustment	B
6. Dieseling (Run-on)	Engine control system <Ref. to EN(H4DOTC)-2, Basic Diagnostic Procedure.>		A
	Cooling system	Overheating	B
	Others	Malfunction of evaporative emission control system	B
7. Afterburning in exhaust system	Engine control system <Ref. to EN(H4DOTC)-2, Basic Diagnostic Procedure.>		A
	Intake system	Loosened or cracked intake duct	C
		Loosened or cracked PCV hose	C
		Loosened or cracked vacuum hose	B
		Defective PCV valve	B
		Loosened oil filler cap	C
	Belt	Defective timing	B
	Compression	Incorrect valve clearance	B
		Loosened spark plugs or defective gasket	C
		Loosened cylinder head bolts or defective gasket	C
		Improper valve seating	B
		Defective valve stem	C
		Worn or broken valve spring	C
		Worn or stuck piston rings, cylinder and piston	C
		Incorrect valve timing	A
	Lubrication system	Incorrect oil pressure	C
Cooling system	Over cooling	C	
Others	Malfunction of evaporative emission control system	C	
8. Knocking	Engine control system <Ref. to EN(H4DOTC)-2, Basic Diagnostic Procedure.>		A
	Intake system	Loosened oil filler cap	B
	Belt	Defective timing	B
	Compression	Incorrect valve clearance	C
		Incorrect valve timing	B
	Cooling system	Overheating	A
9. Excessive engine oil consumption	Intake system	Loosened or cracked PCV hose	A
		Defective PCV valve	B
		Loosened oil filler cap	C
	Compression	Defective valve stem	A
		Worn or stuck piston rings, cylinder and piston	A
	Lubrication system	Loosened oil pump attaching bolts and defective gasket	B
		Defective oil filter o-ring	B
		Defective crankshaft oil seal	B
		Defective rocker cover gasket	B
		Loosened oil drain plug or defective gasket	B
	Loosened oil pan fitting bolts or defective oil pan	B	

ENGINE TROUBLE IN GENERAL

MECHANICAL

TROUBLE	PROBLEM PARTS, ETC.	POSSIBLE CAUSE	RANK	
10. Excessive fuel consumption	Engine control system <Ref. to EN(H4DOTC)-2, Basic Diagnostic Procedure.>		A	
	Intake system	Dirty air cleaner element	A	
	Belt	Defective timing	B	
	Compression	Incorrect valve clearance		B
		Loosened spark plugs or defective gasket		C
		Loosened cylinder head bolts or defective gasket		C
		Improper valve seating		B
		Defective valve stem		C
		Worn or broken valve spring		C
		Worn or stuck piston rings, cylinder and piston		B
		Incorrect valve timing		B
	Lubrication system	Incorrect oil pressure	C	
	Cooling system	Over cooling	C	
	Others	Accelerator cable out of adjustment	B	

ENGINE NOISE

MECHANICAL

26.Engine Noise

A: INSPECTION

Type of sound	Condition	Possible cause
Regular clicking sound	Sound increases as engine speed increases.	<ul style="list-style-type: none"> Valve mechanism is defective. Incorrect valve clearance Worn valve rocker Worn camshaft Broken valve spring
Heavy and dull clank	Oil pressure is low.	<ul style="list-style-type: none"> Worn crankshaft main bearing Worn connecting rod bearing (big end)
	Oil pressure is normal.	<ul style="list-style-type: none"> Loose flywheel mounting bolts Damaged engine mounting
High-pitched clank (Spark knock)	Sound is noticeable when accelerating with an overload.	<ul style="list-style-type: none"> Ignition timing advanced Accumulation of carbon inside combustion chamber Wrong spark plug Improper gasoline
Clank when engine speed is medium (1,000 to 2,000 rpm).	Sound is reduced when fuel injector connector of noisy cylinder is disconnected. (NOTE*)	<ul style="list-style-type: none"> Worn crankshaft main bearing Worn bearing at crankshaft end of connecting rod
Knocking sound when engine is operating under idling speed and engine is warm	Sound is reduced when fuel injector connector of noisy cylinder is disconnected. (NOTE*)	<ul style="list-style-type: none"> Worn cylinder liner and piston ring Broken or stuck piston ring Worn piston pin and hole at piston end of connecting rod
	Sound is not reduced if each fuel injector connector is disconnected in turn. (NOTE*)	<ul style="list-style-type: none"> Unusually worn valve lifter Worn cam gear Worn camshaft journal bore in crankcase
Squeaky sound	—	<ul style="list-style-type: none"> Insufficient generator lubrication
Rubbing sound	—	<ul style="list-style-type: none"> Defective generator brush and rotor contact
Gear scream when starting engine	—	<ul style="list-style-type: none"> Defective ignition starter switch Worn gear and starter pinion
Sound like polishing glass with a dry cloth	—	<ul style="list-style-type: none"> Loose drive belt Defective water pump shaft
Hissing sound	—	<ul style="list-style-type: none"> Loss of compression Air leakage in air intake system, hoses, connections or manifolds
Timing belt noise	—	<ul style="list-style-type: none"> Loose timing belt Belt contacting case/adjacent part
Valve tappet noise	—	<ul style="list-style-type: none"> Incorrect valve clearance

NOTE*:

When disconnecting the fuel injector connector, Malfunction Indicator Light illuminates and DTC is stored in ECM memory.

Therefore, carry out the CLEAR MEMORY MODE <Ref. to EN(H4DOTC)-47, Clear Memory Mode.> and INSPECTION MODE <Ref. to EN(H4DOTC)-39, Inspection Mode.> after connecting the fuel injector connector.

ENGINE NOISE

MECHANICAL
