

# FUEL INJECTION (FUEL SYSTEMS)

# *FU(H6DO)*

---

	<b>Page</b>
1. General Description .....	2
2. Throttle Body .....	16
3. Intake Manifold .....	17
4. Engine Coolant Temperature Sensor .....	29
5. Crankshaft Position Sensor .....	30
6. Camshaft Position Sensor .....	31
7. Knock Sensor .....	32
8. Throttle Position Sensor .....	33
9. Intake Manifold Pressure Sensor .....	34
10. Intake Air Temperature Sensor .....	35
11. Idle Air Control Solenoid Valve .....	36
12. Induction Valve .....	37
13. Induction Valve Control Solenoid .....	38
14. Fuel Injector .....	39
15. Front Oxygen (A/F) Sensor .....	43
16. Rear Oxygen Sensor .....	45
17. Engine Control Module .....	46
18. Main Relay .....	47
19. Fuel Pump Relay .....	48
20. Fuel Pump Controller .....	49
21. Fuel .....	50
22. Fuel Tank .....	53
23. Fuel Filler Pipe .....	61
24. Fuel Pump .....	68
25. Fuel Level Sensor .....	70
26. Fuel Sub Level Sensor .....	71
27. Fuel Filter .....	72
28. Fuel Cut Valve .....	73
29. Fuel Damper Valve .....	74
30. Fuel Delivery, Return and Evaporation Lines .....	75
31. Fuel System Trouble in General .....	78

# GENERAL DESCRIPTION

## FUEL INJECTION (FUEL SYSTEMS)

---

### 1. General Description

#### A: SPECIFICATIONS

Model		
Fuel tank	Capacity	64 ℓ (16.9 US gal, 14.1 Imp gal)
	Location	Under rear seat
Fuel pump	Type	Impeller
	Shutoff discharge pressure	370 — 677 kPa (3.77 — 6.9 kg/cm <sup>2</sup> , 53.6 — 98 psi)
	Discharge flow	More than 85 ℓ (22.5 US gal, 18.7 Imp gal)/h [12 V at 300 kPa (3.06 kg/cm <sup>2</sup> , 43.5 psi)]
Fuel filter		Cartridge type

# GENERAL DESCRIPTION

FUEL INJECTION (FUEL SYSTEMS)

---

**MEMO:**

# GENERAL DESCRIPTION

FUEL INJECTION (FUEL SYSTEMS)

## B: COMPONENT

### 1. INTAKE MANIFOLD

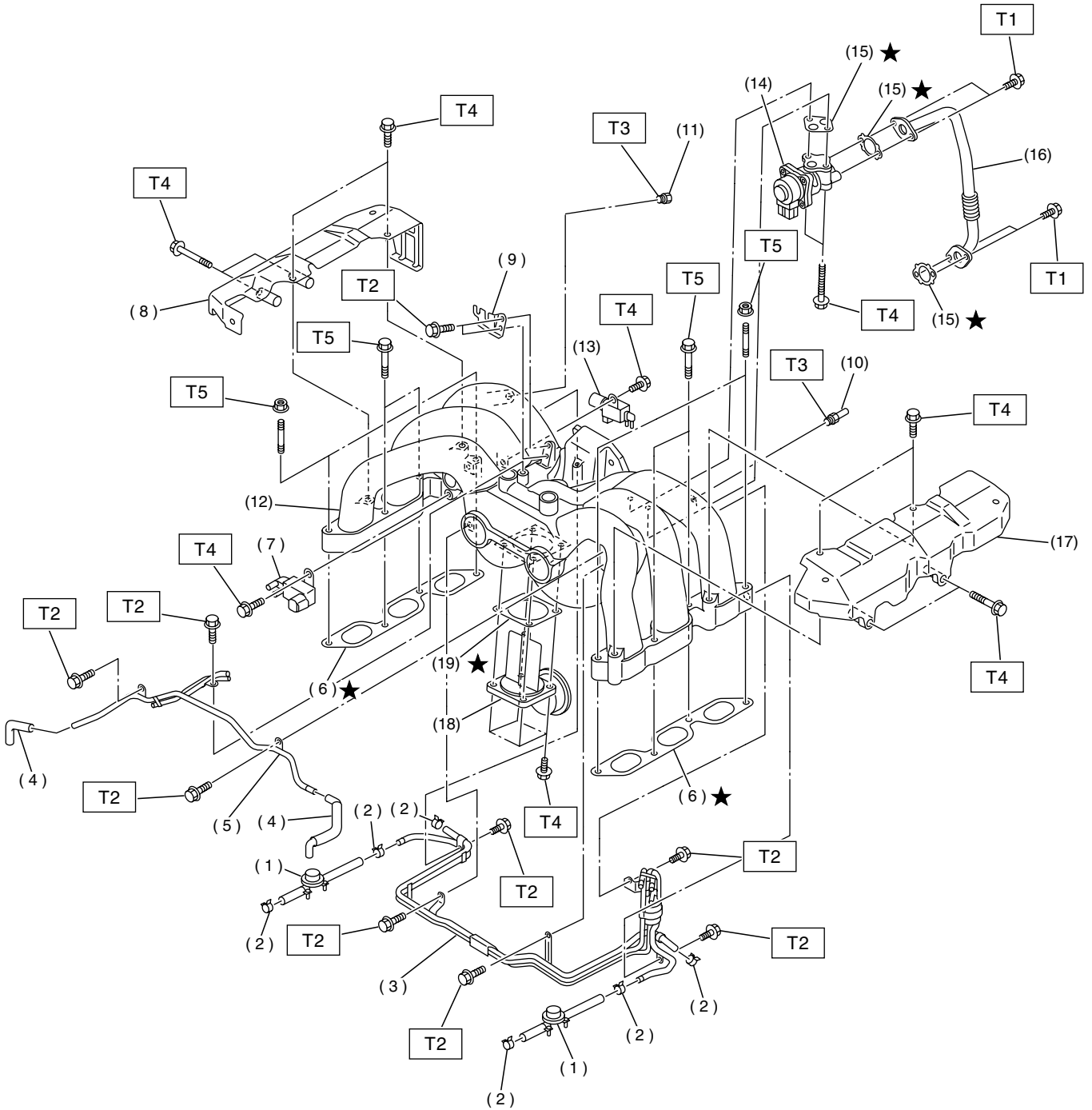

FU-02030

FU(H6DO)-4

# GENERAL DESCRIPTION

## FUEL INJECTION (FUEL SYSTEMS)

- |                                    |                                       |             |
|------------------------------------|---------------------------------------|-------------|
| (1) Fuel damper valve              | (10) Nipple                           | (19) Gasket |
| (2) Clamp                          | (11) Plug                             |             |
| (3) Fuel pipe ASSY                 | (12) Intake manifold                  |             |
| (4) Air assist hose                | (13) Induction valve control solenoid |             |
| (5) Air assist and purge pipe ASSY | (14) EGR valve                        |             |
| (6) Gasket                         | (15) Gasket                           |             |
| (7) Purge control solenoid valve   | (16) EGR pipe                         |             |
| (8) Fuel pipe protector RH         | (17) Fuel pipe protector LH           |             |
| (9) Accelerator cable bracket      | (18) Induction valve                  |             |

---

***Tightening torque: N·m (kgf-m, ft-lb)******T1: 6.4 (0.65, 4.7)******T2: 5.0 (0.51, 3.7)******T3: 17 (1.7, 12)******T4: 19 (1.9, 14)******T5: 25 (2.5, 18)***

---

# GENERAL DESCRIPTION

## FUEL INJECTION (FUEL SYSTEMS)

### 2. FUEL INJECTOR

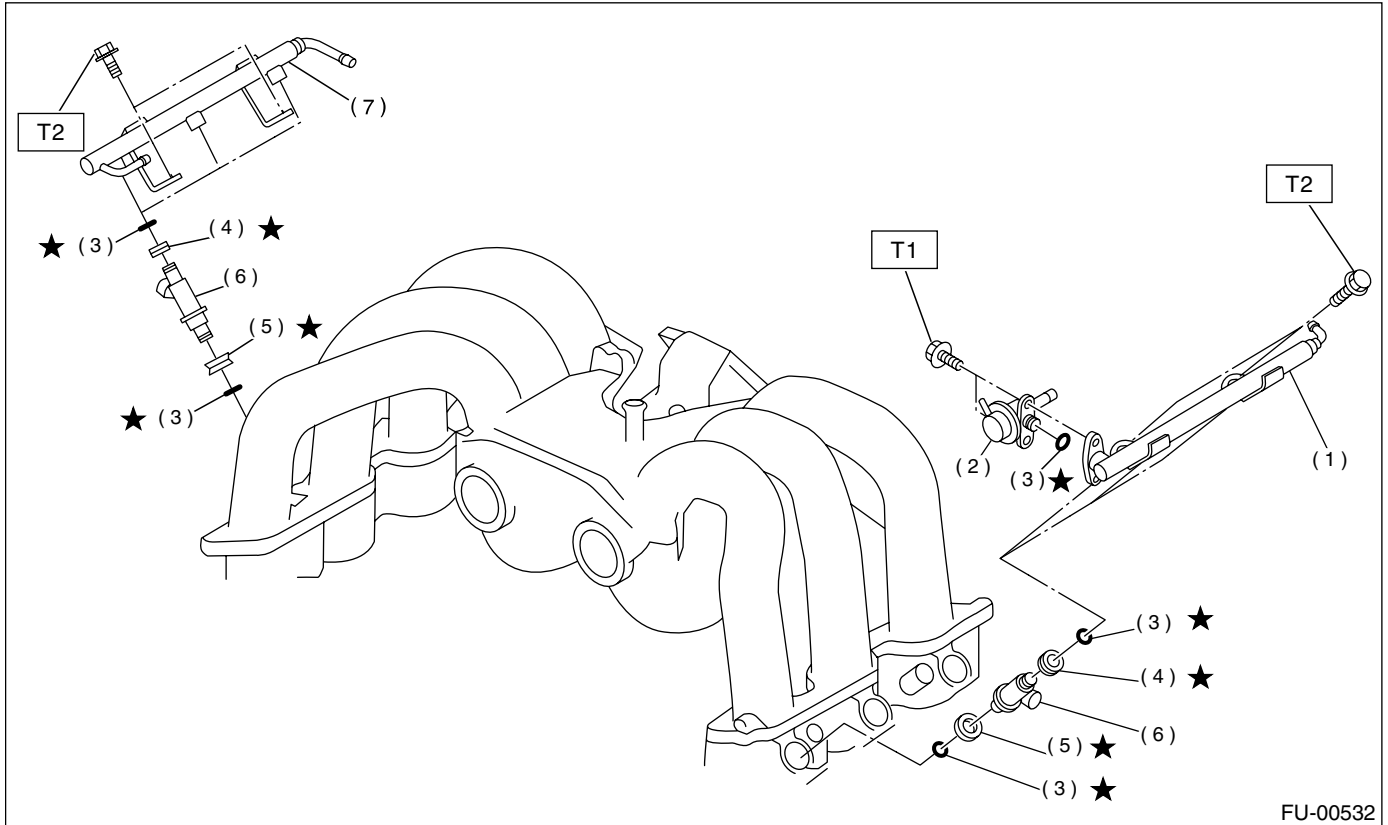

- (1) Fuel injector pipe LH
- (2) Pressure regulator
- (3) O-ring
- (4) Injection rubber
- (5) Insulator
- (6) Fuel injector
- (7) Fuel injector pipe RH

**Tightening torque: N·m (kgf·m, ft·lb)**

**T1: 6.4 (0.65, 4.7)**

**T2: 19 (1.9, 14)**

# GENERAL DESCRIPTION

FUEL INJECTION (FUEL SYSTEMS)

## 3. AIR INTAKE SYSTEM

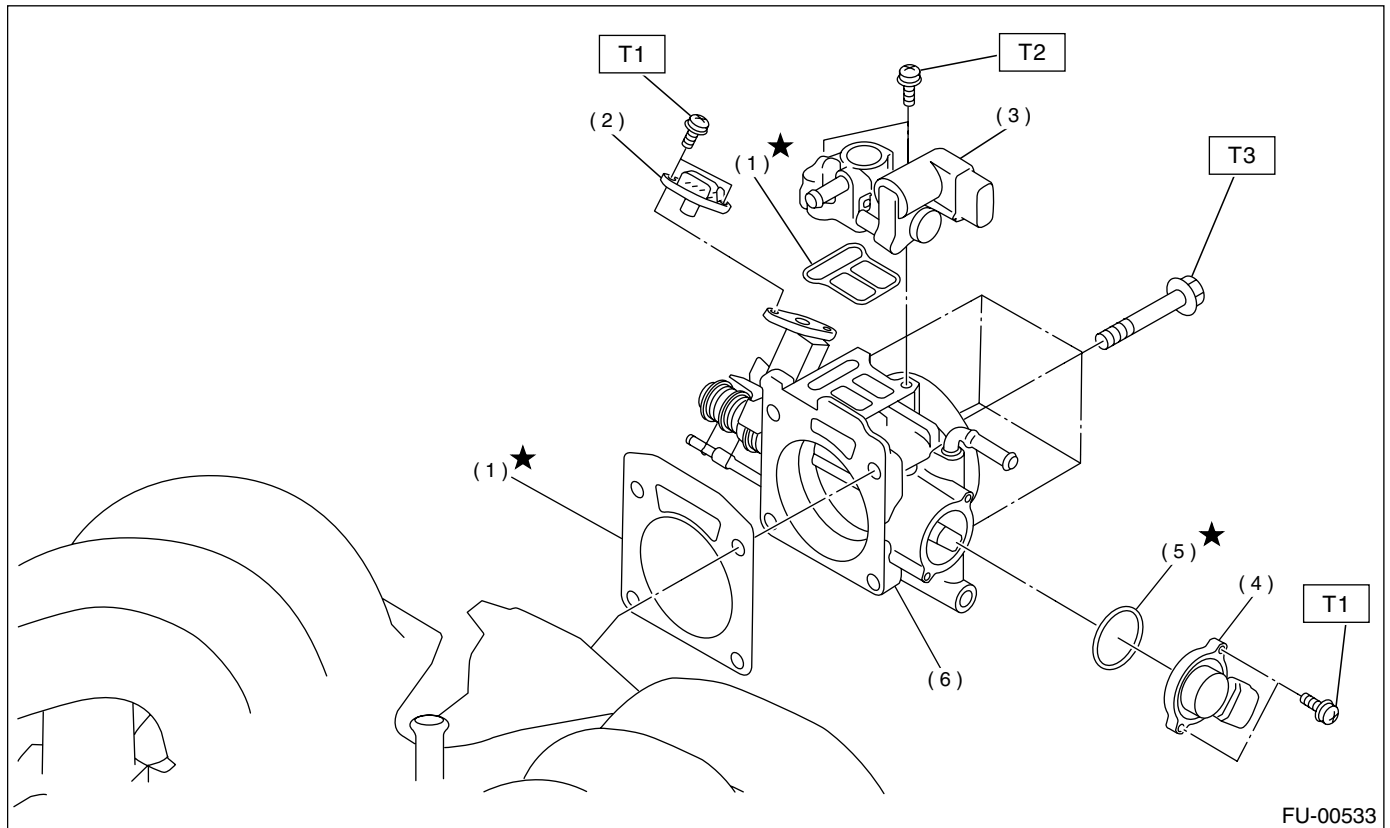

- |                                     |                   |
|-------------------------------------|-------------------|
| (1) Gasket                          | (5) O-ring        |
| (2) Intake manifold pressure sensor | (6) Throttle body |
| (3) Idle air control solenoid valve |                   |
| (4) Throttle position sensor        |                   |

**Tightening torque: N·m (kgf·m, ft·lb)**

**T1: 1.6 (0.16, 1.2)**

**T2: 2.8 (0.29, 2.1)**

**T3: 22 (2.2, 15.9)**

# GENERAL DESCRIPTION

FUEL INJECTION (FUEL SYSTEMS)

## 4. CRANKSHAFT POSITION, CAMSHAFT POSITION AND KNOCK SENSORS

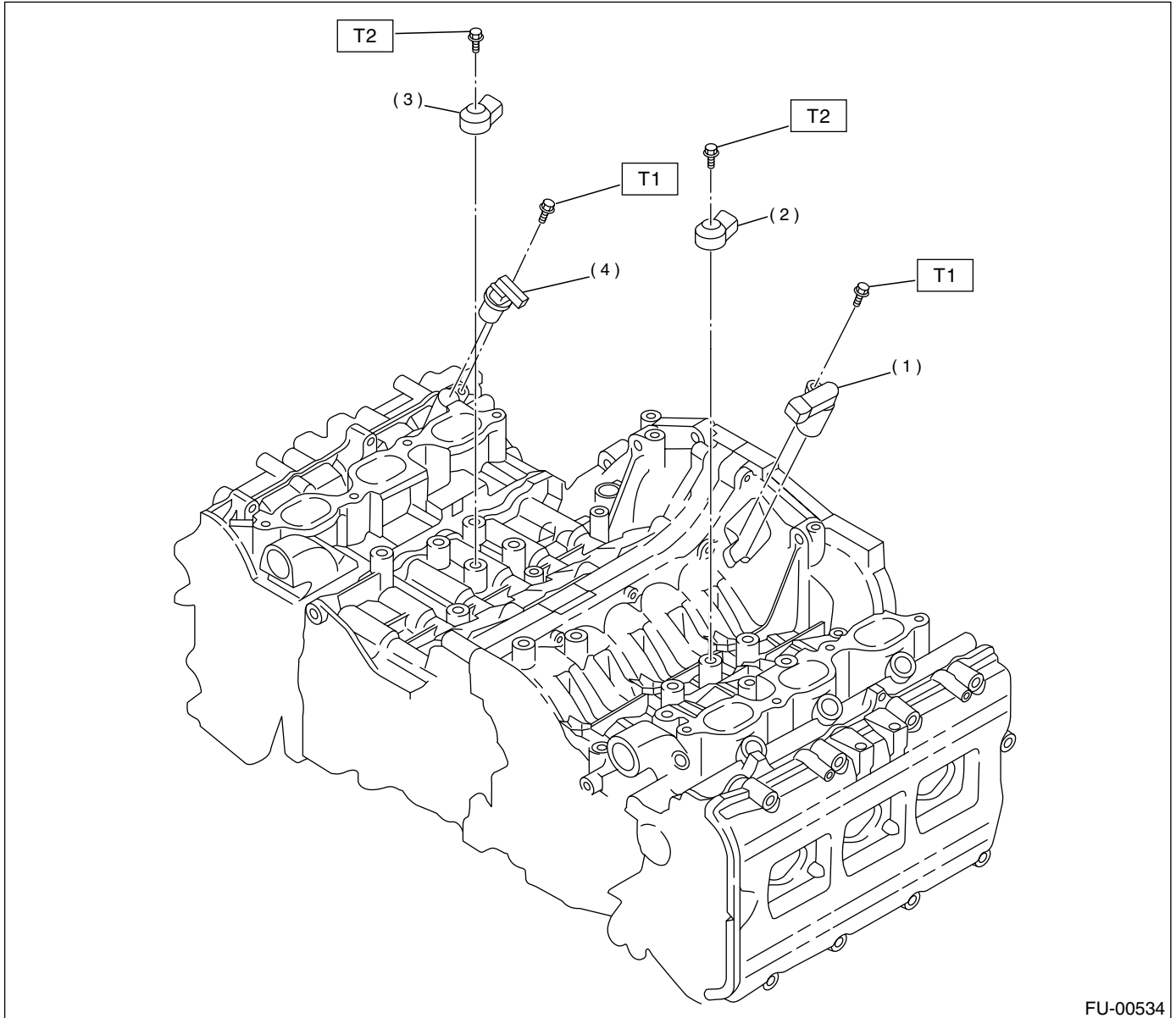

FU-00534

- |                                |                              |
|--------------------------------|------------------------------|
| (1) Crankshaft position sensor | (3) Knock sensor RH          |
| (2) Knock sensor LH            | (4) Camshaft position sensor |

**Tightening torque: N·m (kgf-m, ft-lb)**

**T1: 6.4 (0.65, 4.7)**

**T2: 25 (2.5, 18)**



# GENERAL DESCRIPTION

FUEL INJECTION (FUEL SYSTEMS)

---

**MEMO:**

# GENERAL DESCRIPTION

## FUEL INJECTION (FUEL SYSTEMS)

### 5. FUEL TANK

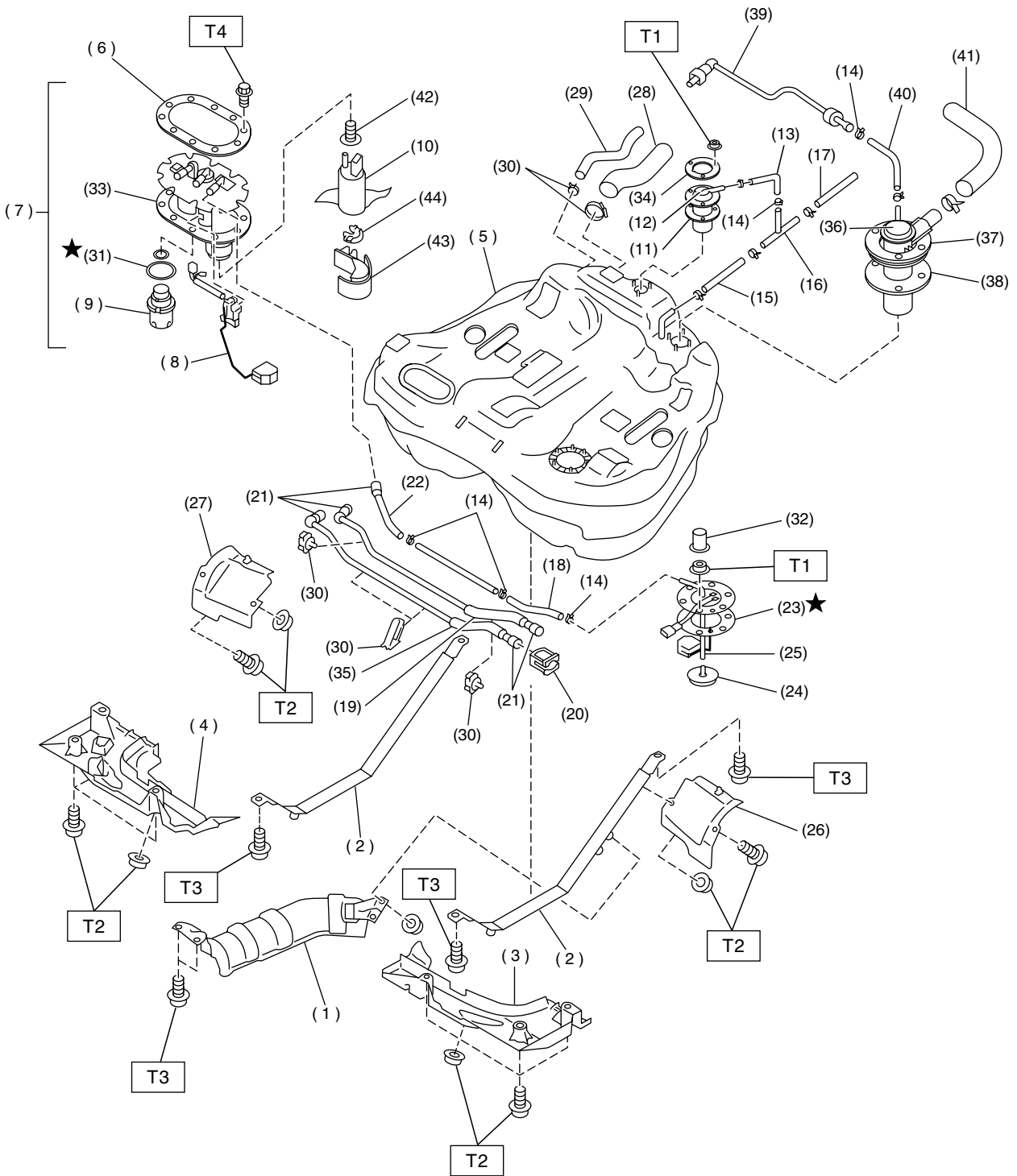

FU-01250

# GENERAL DESCRIPTION

## FUEL INJECTION (FUEL SYSTEMS)

- |                            |                                     |                         |
|----------------------------|-------------------------------------|-------------------------|
| (1) Heat sealed cover      | (18) Jet pump hose A                | (35) Fuel delivery tube |
| (2) Fuel tank band         | (19) Fuel return tube               | (36) Vent valve         |
| (3) Protector LH (Front)   | (20) Retainer                       | (37) Vent valve plate   |
| (4) Protector RH (Front)   | (21) Quick connector                | (38) Vent valve gasket  |
| (5) Fuel tank              | (22) Jet pump tube B                | (39) Evaporation tube   |
| (6) Fuel pump plate        | (23) Fuel sub level sensor gasket   | (40) Evaporation hose D |
| (7) Fuel pump ASSY         | (24) Jet pump filter                | (41) Air vent hose      |
| (8) Fuel level sensor      | (25) Fuel sub level sensor          | (42) Seal               |
| (9) Fuel filter            | (26) Protector LH (Rear)            | (43) Fuel pump holder   |
| (10) Fuel pump             | (27) Protector RH (Rear)            | (44) Rubber lower       |
| (11) Fuel cut valve gasket | (28) Fuel filler hose               |                         |
| (12) Fuel cut valve        | (29) Fuel tank pressure sensor hose |                         |
| (13) Evaporation hose A    | (30) Clamp                          |                         |
| (14) Clip                  | (31) Gasket                         |                         |
| (15) Evaporation hose C    | (32) Cap                            |                         |
| (16) Joint pipe            | (33) Gasket                         |                         |
| (17) Evaporation hose B    | (34) Fuel cut valve plate           |                         |

---

**Tightening torque: N·m (kgf-m, ft-lb)****T1: 4.4 (0.45, 3.3)****T2: 18 (1.8, 13.0)****T3: 33 (3.4, 25)****T4: 5.9 (0.6, 4.3)**

---

# GENERAL DESCRIPTION

## FUEL INJECTION (FUEL SYSTEMS)

### 6. FUEL LINE

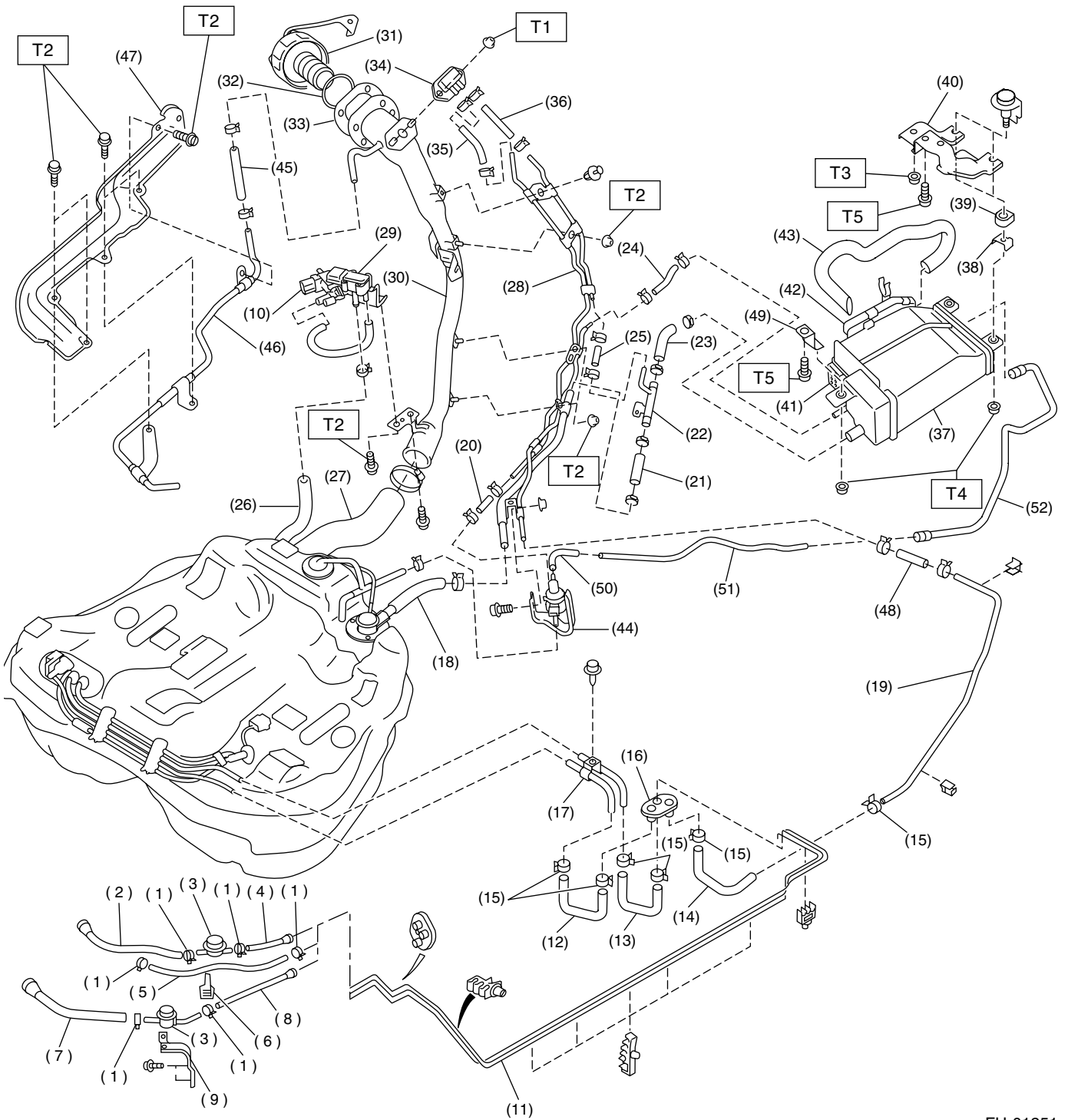

FU-01251

# GENERAL DESCRIPTION

## FUEL INJECTION (FUEL SYSTEMS)

- |                                     |                                      |                             |
|-------------------------------------|--------------------------------------|-----------------------------|
| (1) Clamp                           | (23) Air vent hose C                 | (45) Evaporation hose H     |
| (2) Fuel return hose A              | (24) Evaporation hose D              | (46) Evaporation pipe C     |
| (3) Fuel damper valve               | (25) Evaporation hose E              | (47) Pipe protector         |
| (4) Fuel return hose B              | (26) Fuel tank pressure sensor hose  | (48) Evaporation hose I     |
| (5) Evaporation hose A              | (27) Fuel filler hose                | (49) Canister front bracket |
| (6) Clip                            | (28) Evaporation pipe B              | (50) PCV hose               |
| (7) Fuel delivery hose A            | (29) Fuel tank pressure sensor       | (51) PCV pipe               |
| (8) Fuel delivery hose B            | (30) Fuel filler pipe                | (52) PCV tube               |
| (9) Fuel damper valve bracket       | (31) Fuel filler cap                 |                             |
| (10) Fuel tank sensor control valve | (32) Ring                            |                             |
| (11) Fuel pipe ASSY                 | (33) Packing                         |                             |
| (12) Fuel delivery hose C           | (34) Shut valve                      |                             |
| (13) Fuel return hose C             | (35) Evaporation hose F              |                             |
| (14) Evaporation hose B             | (36) Evaporation hose G              |                             |
| (15) Clamp                          | (37) Canister                        |                             |
| (16) Grommet                        | (38) Canister lower bracket          |                             |
| (17) Fuel pipe ASSY                 | (39) Cushion rubber                  |                             |
| (18) Air vent hose A                | (40) Canister upper bracket          |                             |
| (19) Evaporation pipe A             | (41) Drain valve                     |                             |
| (20) Evaporation hose C             | (42) Drain filter                    |                             |
| (21) Air vent hose B                | (43) Drain hose                      |                             |
| (22) Air vent pipe                  | (44) Pressure control solenoid valve |                             |

---

**Tightening torque: N-m (kgf-m, ft-lb)****T1: 4.5 (0.46, 3.3)****T2: 7.5 (0.76, 5.5)****T3: 18 (1.8, 13.0)****T4: 23 (2.3, 16.6)****T5: 33 (3.4, 25)**

---

# GENERAL DESCRIPTION

## FUEL INJECTION (FUEL SYSTEMS)

### 7. FUEL FILLER PIPE

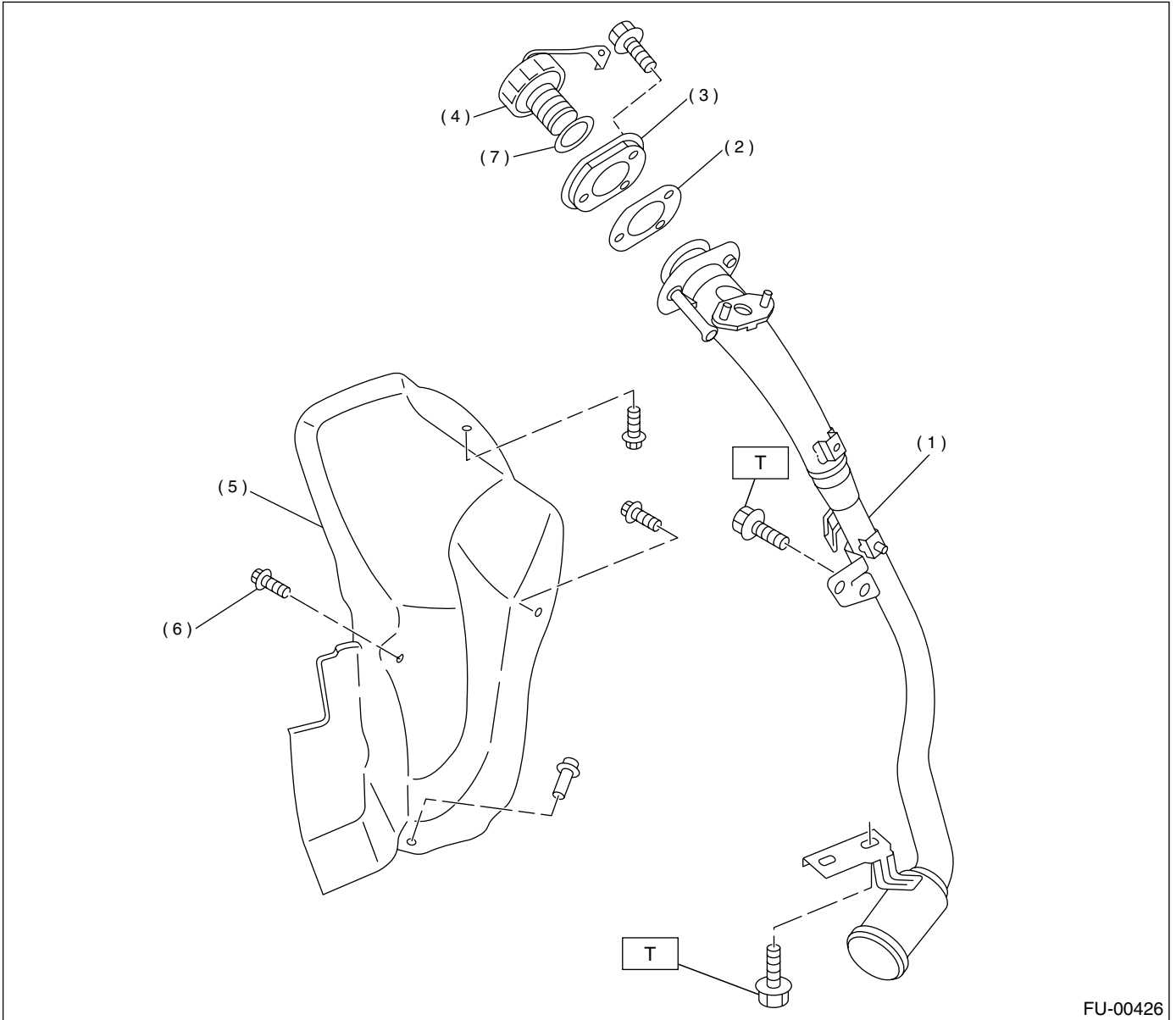

FU-00426

- (1) Fuel filler pipe ASSY
- (2) Filler pipe packing
- (3) Filler ring
- (4) Filler cap
- (5) Filler pipe protector
- (6) Clip
- (7) Ring

**Tightening torque: N·m (kgf-m, ft-lb)**

**T: 7.5 (0.75, 5.4)**

# GENERAL DESCRIPTION



## FUEL INJECTION (FUEL SYSTEMS)

### C: CAUTION

- Wear working clothing, including a cap, protective goggles, and protective shoes during operation.
- Remove contamination including dirt and corrosion before removal, installation or disassembly.
- Keep the disassembled parts in order and protect them from dust or dirt.
- Before removal, installation or disassembly, be sure to clarify the failure. Avoid unnecessary removal, installation, disassembly, and replacement.

- Be careful not to burn your hands, because each part on the vehicle is hot after running.
- Be sure to tighten fasteners including bolts and nuts to the specified torque.
- Place shop jacks or safety stands at the specified points.
- Before disconnecting electrical connectors of sensors or units, be sure to disconnect ground cable from battery.
- Place "NO FIRE" signs near the working area.
- Be careful not to spill fuel on the floor.

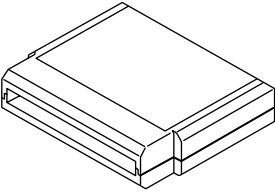
### D: PREPARATION TOOL

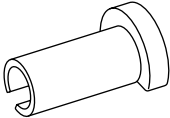
ILLUSTRATION	TOOL NUMBER	DESCRIPTION	REMARKS
 <p>ST24082AA230</p>	24082AA230	CARTRIDGE	Troubleshooting for electrical systems.
 <p>ST22771AA030</p>	22771AA030	SELECT MONITOR KIT	Troubleshooting for electrical systems.
 <p>ST42099AE000</p>	42099AE000	CONNECTOR REMOVER	Used for disconnecting quick connector.

# THROTTLE BODY

FUEL INJECTION (FUEL SYSTEMS)

## 2. Throttle Body

### A: REMOVAL

1) Disconnect ground cable from battery.

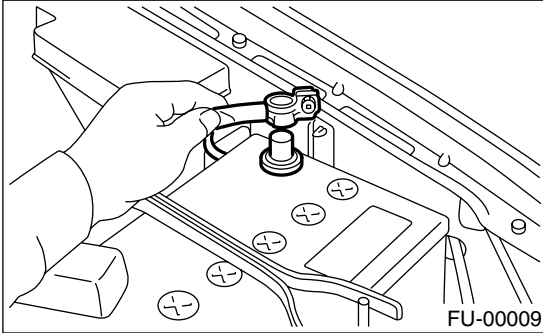

2) Remove air intake chamber.  
<Ref. to IN(H6DO)-6, REMOVAL, Air Intake Chamber.>

3) Disconnect accelerator cable (A).

4) Disconnect cruise control cable (B). (With cruise control model)

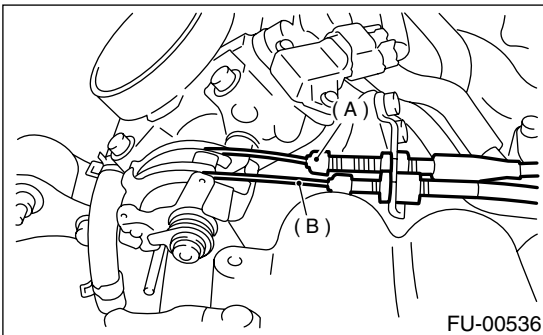

5) Disconnect connectors from intake manifold pressure sensor (A) and idle air control solenoid valve (B).

6) Disconnect air by-pass hose (C) from idle air control solenoid valve.

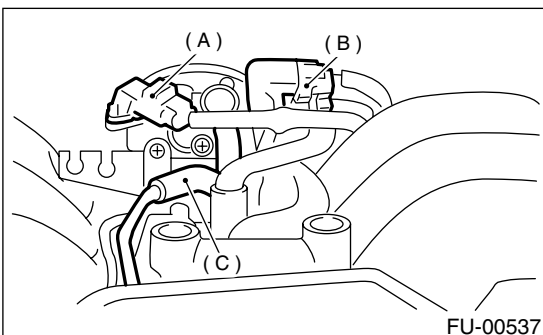

7) Disconnect throttle position sensor connector.

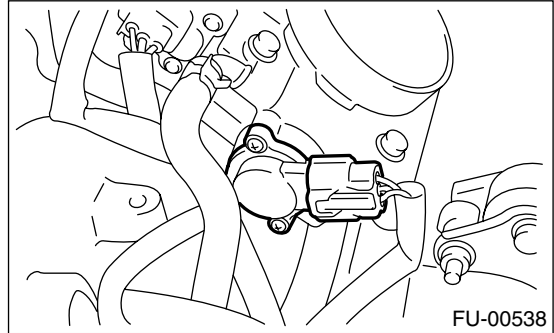

8) Disconnect engine coolant hoses from throttle body.

9) Remove bolts which secure throttle body to intake manifold.

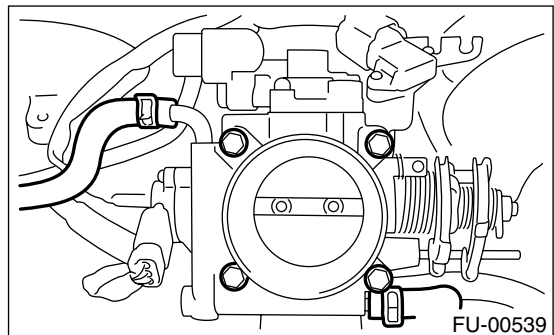

### B: INSTALLATION

Install in the reverse order of removal.

NOTE:

When removing throttle body, replace gasket with new one.

**Tightening torque:**

**Throttle body;**

**22 N·m (2.2 kgf-m, 15.9 ft-lb)**



### 3. Intake Manifold

#### A: REMOVAL

- 1) Release fuel pressure. <Ref. to FU(H6DO)-50, RELEASING OF FUEL PRESSURE, OPERATION, Fuel.>
- 2) Open fuel flap lid, and remove fuel filler cap.
- 3) Disconnect ground cable from battery.

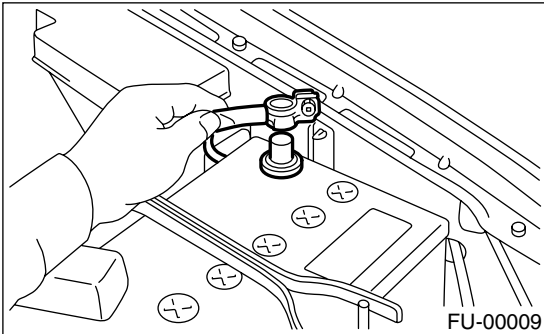

- 4) Remove air intake duct, air cleaner assembly and air intake chamber. <Ref. to IN(H6DO)-7, REMOVAL, Air Intake Duct.> and <Ref. to IN(H6DO)-5, REMOVAL, Air Cleaner.> or <Ref. to IN(H6DO)-6, REMOVAL, Air Intake Chamber.>
- 5) Disconnect accelerator cable (A).
- 6) Disconnect cruise control cable (B). (With cruise control model)

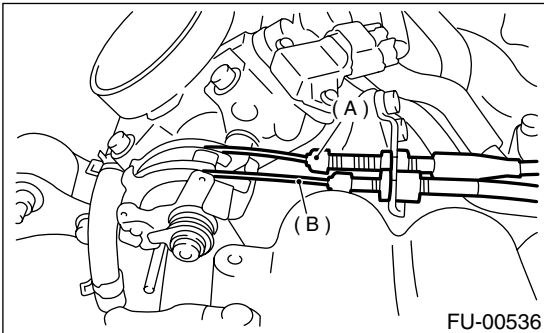

- 7) Remove power steering pump and tank from brackets.
  - (1) Remove V-belt. <Ref. to ME(H6DO)-28, REMOVAL, V-belt.>
  - (2) Remove power steering oil pipe with bracket.

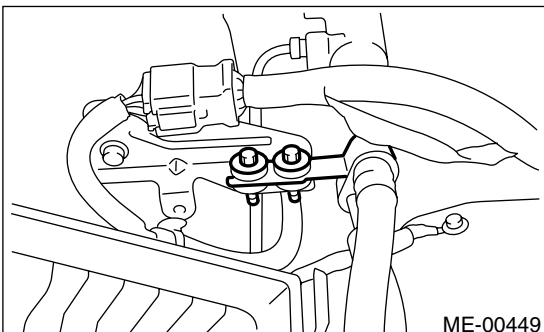

- (3) Remove bolts which install power steering pump bracket.

#### NOTE:

Do not disconnect power steering hose.

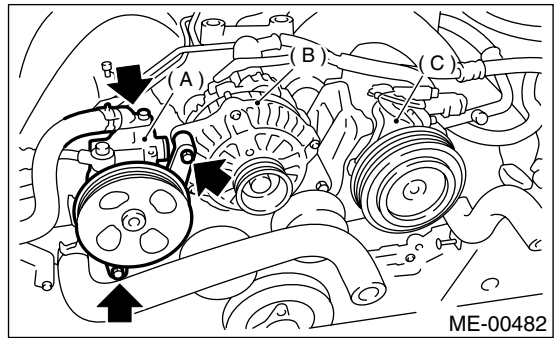

- (A) Power steering pump
- (B) Generator
- (C) A/C compressor

- (4) Disconnect connector from power steering pump switch.

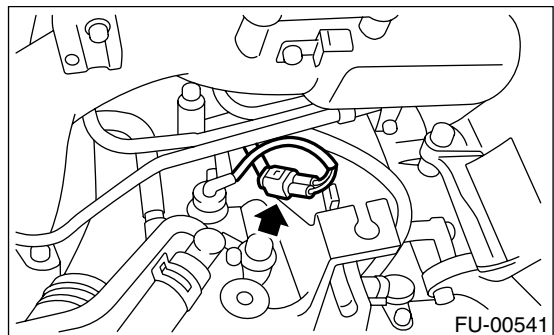

- (5) Remove power steering tank from the bracket by pulling it upward.

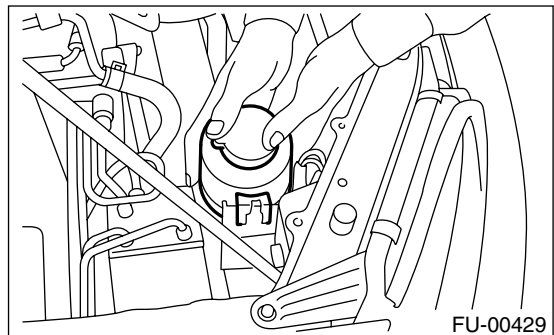

# INTAKE MANIFOLD

## FUEL INJECTION (FUEL SYSTEMS)

(6) Place power steering pump on the right side wheel apron.

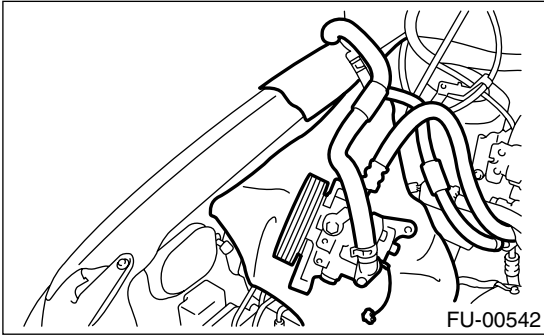

8) Remove two bolts which install washer tank on body.

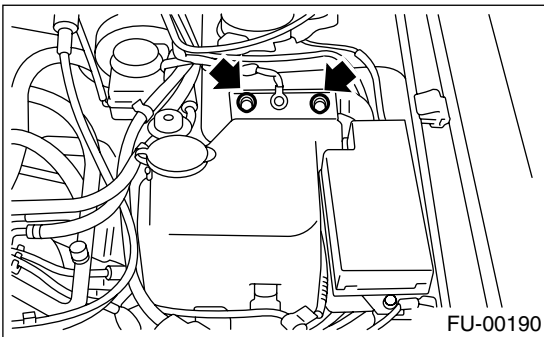

9) Disconnect connector from front window washer motor.

10) Disconnect connector from rear gate glass washer motor.

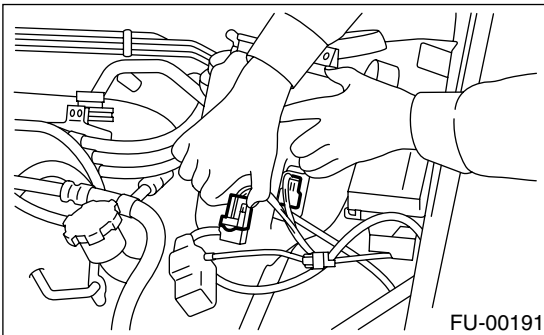

11) Disconnect rear window glass washer hose from washer motor, then plug connection with a suitable cap.

12) Move washer tank upward.

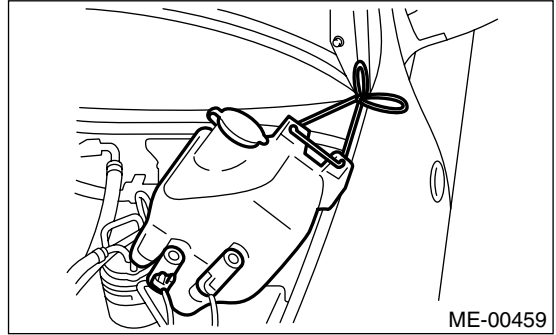

13) Disconnect PCV hoses from cylinder head cover.

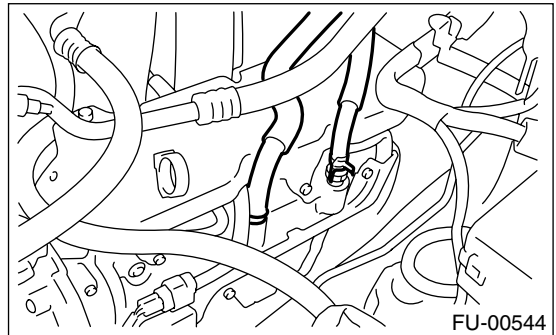

14) Disconnect engine coolant hose from throttle body.

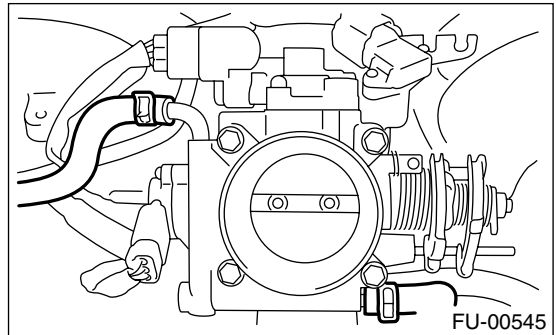

15) Disconnect brake booster hose.

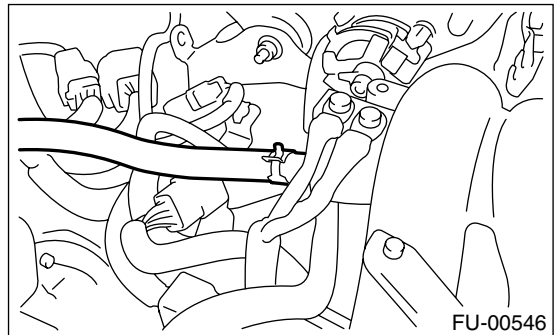

# INTAKE MANIFOLD

FUEL INJECTION (FUEL SYSTEMS)

16) Remove EGR pipe from EGR valve.

**NOTE:**

Be careful not to drop gaskets.

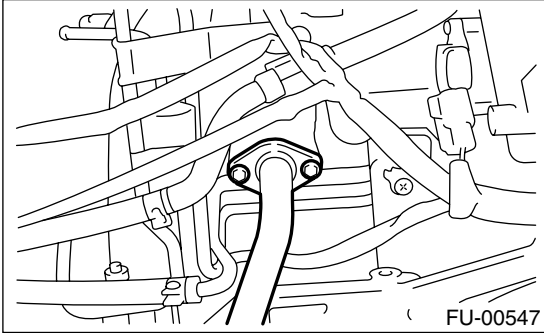

17) Disconnect engine harness connectors from bulkhead harness connectors.

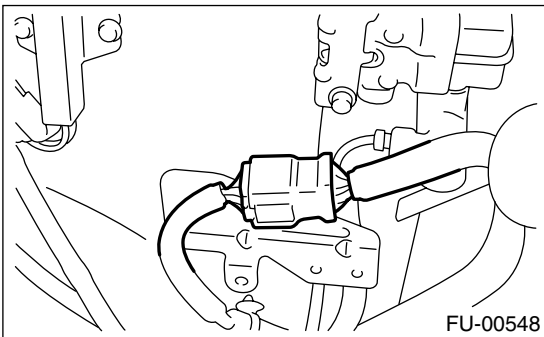

18) Disconnect engine ground terminal from intake manifold.

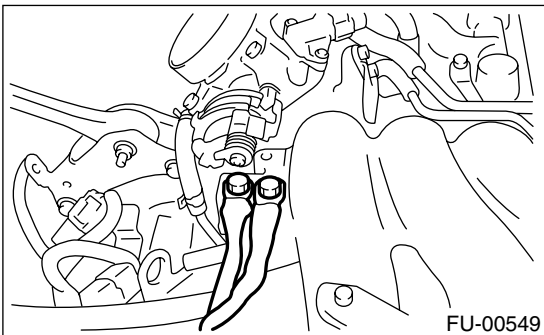

19) Using ST, disconnect fuel delivery hose, return hose and evaporation hose. <Ref. to FU(H6DO)-75, REMOVAL, Fuel Delivery, Return and Evaporation Lines.>

ST 42099AE000 CONNECTOR REMOVER

**WARNING:**

- Do not spill fuel.
- Catch fuel from hoses in a container or cloth.

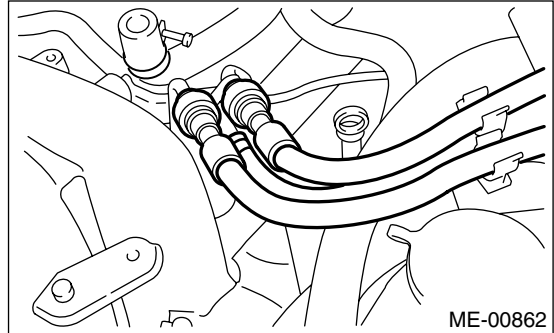

20) Remove ground cable from fuel pipe protector LH.

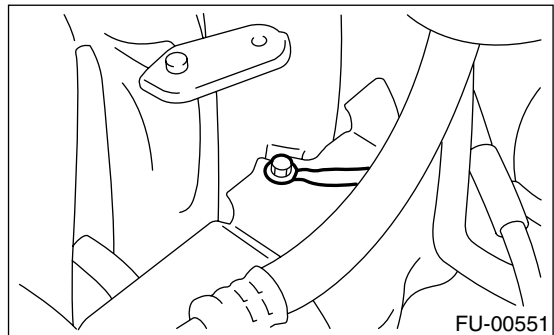

21) Remove fuel pipe protector LH.

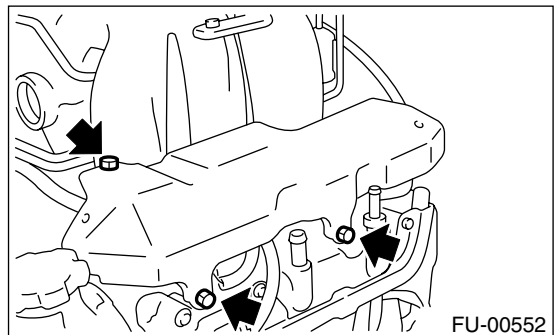

22) Disconnect air assist hose (A).

# INTAKE MANIFOLD

## FUEL INJECTION (FUEL SYSTEMS)

23) Remove the bolt (B), which holds fuel injector pipe LH onto cylinder head.

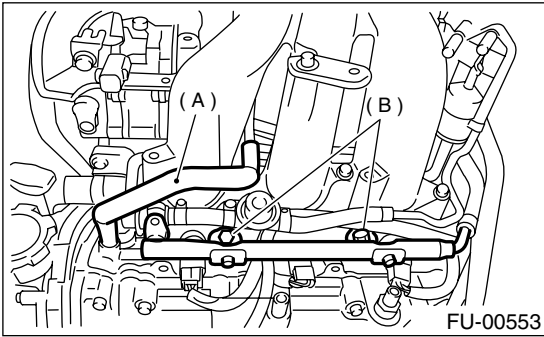

24) Remove ground cable from fuel pipe protector RH.

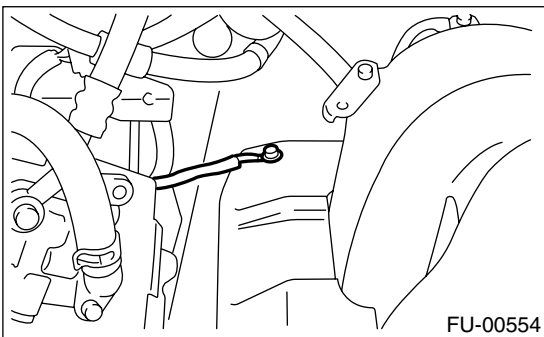

25) Remove fuel pipe protector RH.

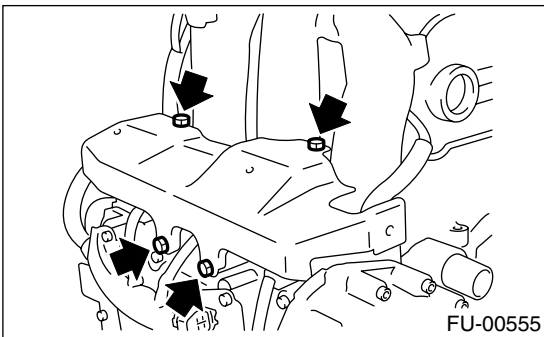

26) Disconnect air assist hose (A).  
Remove the bolt (B), which holds fuel injector pipe RH onto cylinder head.

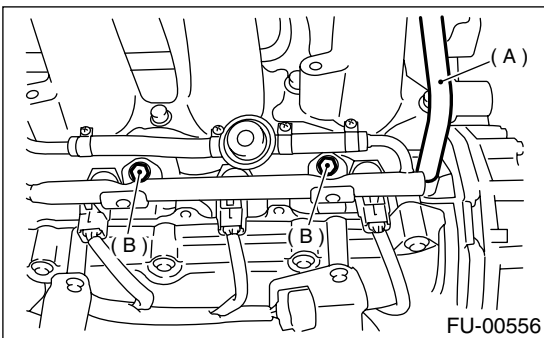

27) Remove bolts which holds intake manifold onto cylinder heads.

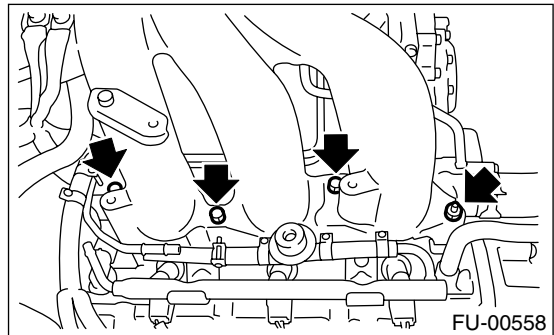
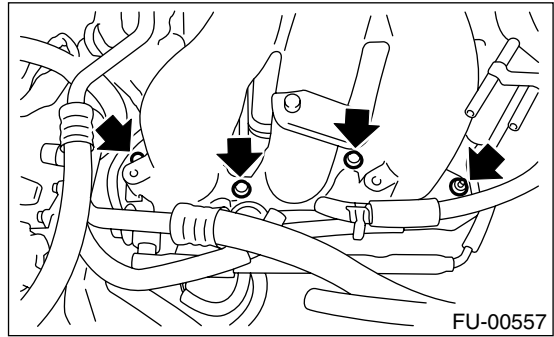

28) Remove intake manifold.

## B: INSTALLATION

1) Install intake manifold onto cylinder heads.

### NOTE:

Always use new gaskets.

### Tightening torque:

**25 N·m (2.5 kgf-m, 18.1 ft-lb)**

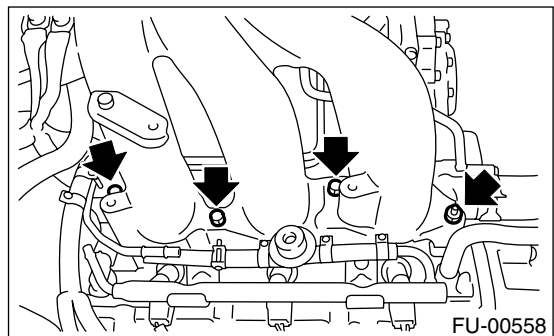
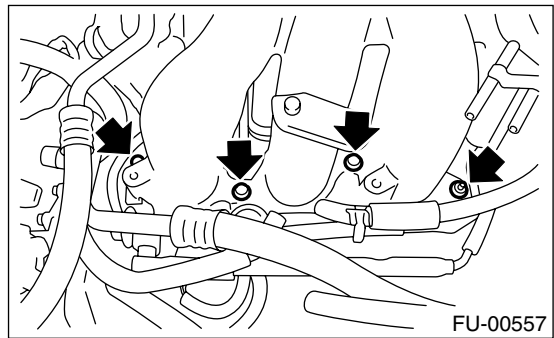

# INTAKE MANIFOLD

FUEL INJECTION (FUEL SYSTEMS)

2) Install the bolt (B), which holds fuel injector pipe RH onto cylinder head.

**Tightening torque:**  
**19 N·m (1.9 kgf-m, 14 ft-lb)**

3) Connect air assist hose (A).

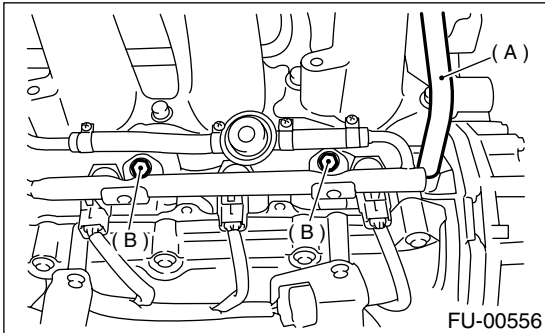

4) Install fuel pipe protector RH.

**Tightening torque:**  
**19 N·m (1.9 kgf-m, 14 ft-lb)**

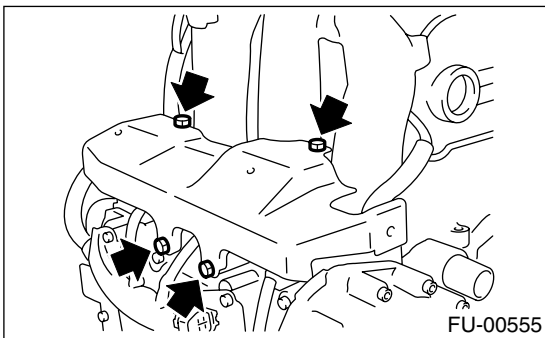

5) Install ground cable to fuel pipe protector RH.

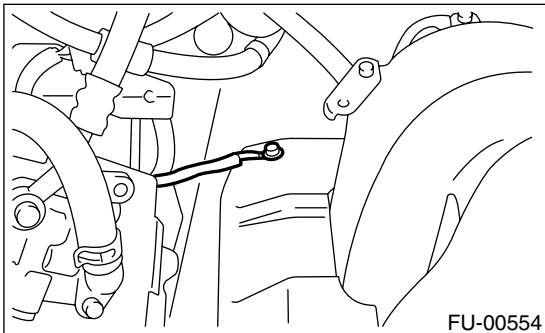

6) Install the bolt (B) which holds fuel injector pipe RH onto cylinder head.

**Tightening torque:**  
**19 N·m (1.9 kgf-m, 14 ft-lb)**

7) Connect air assist hose (A).

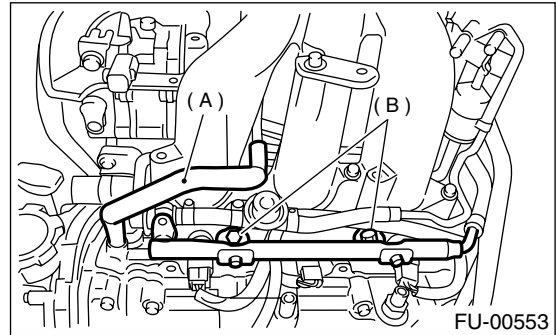

8) Install fuel pipe protector LH.

**Tightening torque:**  
**19 N·m (1.9 kgf-m, 14 ft-lb)**

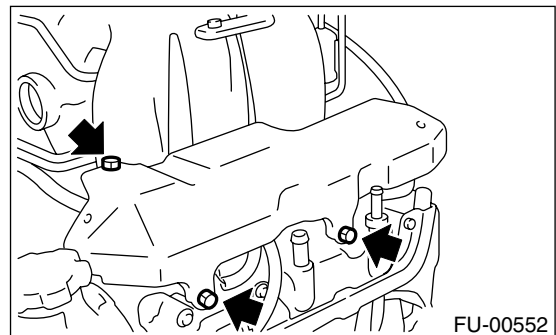

9) Install ground cable to fuel pipe protector LH.

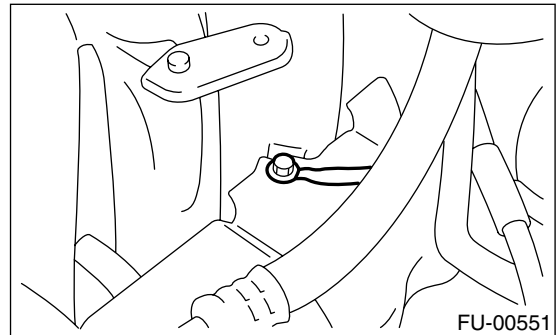

10) Install EGR pipe to EGR valve.

**NOTE:**  
Always use new gasket.

**Tightening torque:**  
**6.4 N·m (0.65 kgf-m, 4.7 ft-lb)**

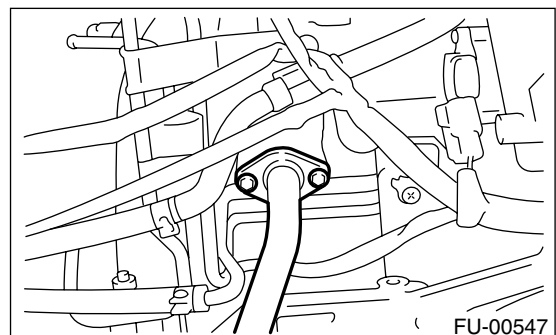

# INTAKE MANIFOLD

## FUEL INJECTION (FUEL SYSTEMS)

11) Connect fuel delivery hose, return hose and evaporation hose. <Ref. to FU(H6DO)-76, INSTALLATION, Fuel Delivery, Return and Evaporation Lines.>

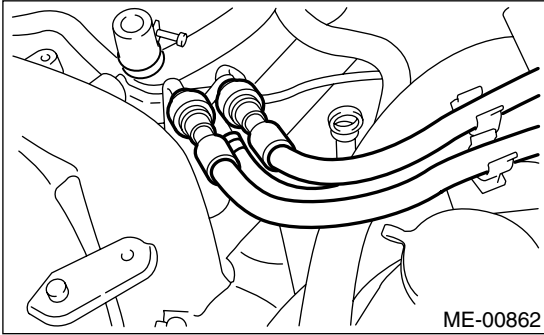

12) Connect engine ground cable to intake manifold.

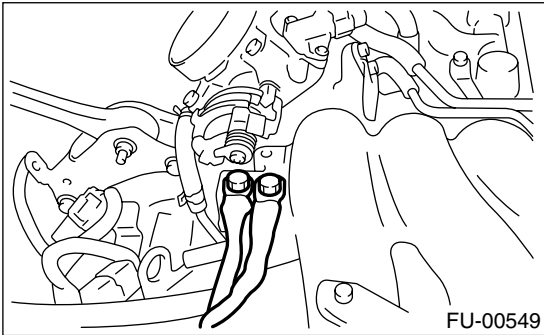

13) Connect engine harness connectors to bulkhead connectors.

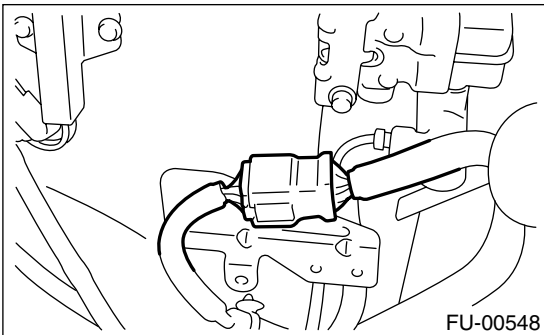

14) Connect brake booster hose.

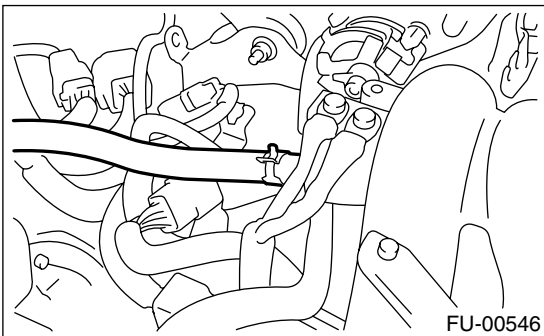

15) Connect engine coolant hose to throttle body.

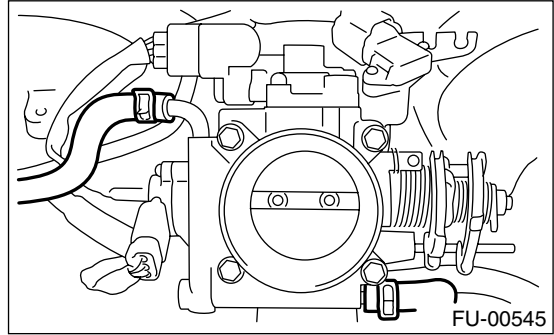

16) Connect PCV hose to cylinder head cover.

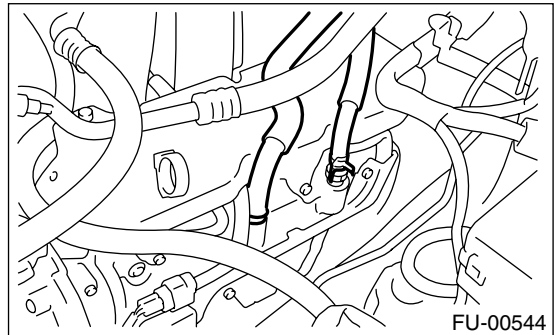

17) Install power steering pump and tank on brackets.

(1) Install power steering tank on bracket.

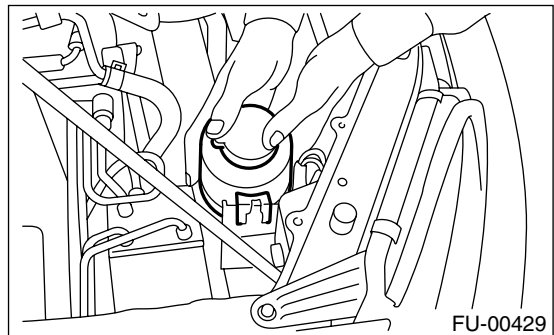

(2) Connect connector to power steering pump switch.

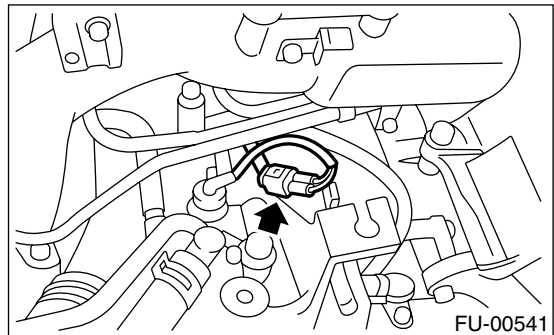

# INTAKE MANIFOLD

## FUEL INJECTION (FUEL SYSTEMS)

(3) Tighten bolts which install power steering pump on bracket.

### Tightening torque:

**20.1 N·m (2.05 kgf·m, 14.8 ft·lb)**

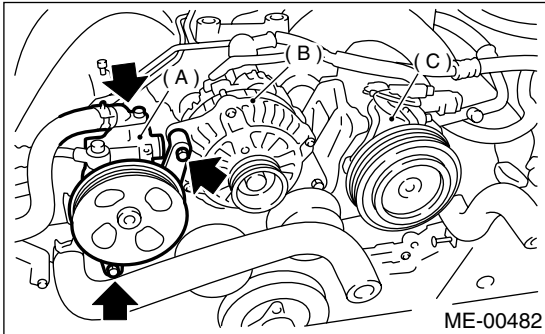

- (A) Power steering pump
- (B) Generator
- (C) A/C compressor

(4) Install power steering pipes with bracket.

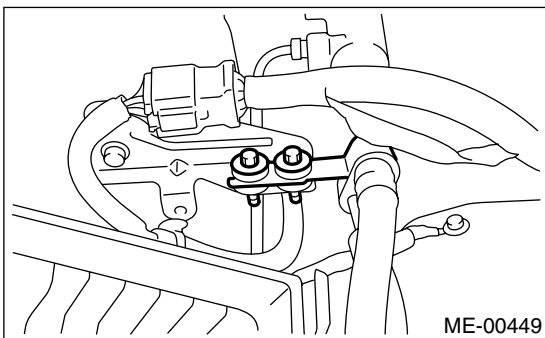

(5) Install V-belt. <Ref. to ME(H6DO)-28, INSTALLATION, V-belt.>

18) Connect rear window washer hose to washer motor.

19) Connect front window washer motor connector.

20) Connect rear window washer motor connector.

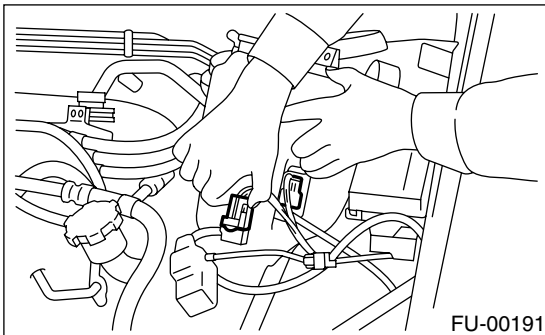

21) Install washer tank on body.

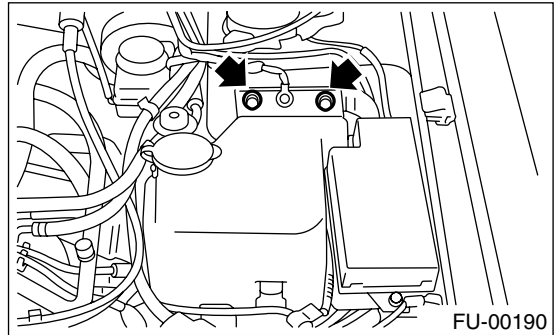

22) Connect accelerator cable (A).

23) Connect cruise control cable (B). (With cruise control models)

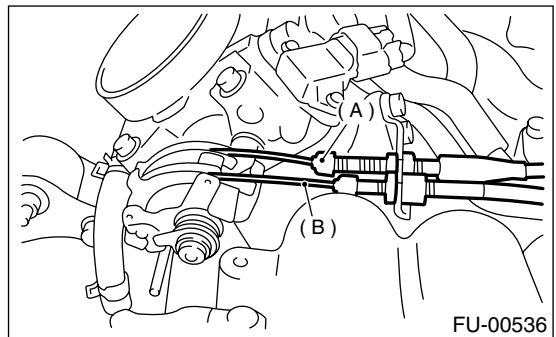

24) Install air intake duct, air cleaner and air intake chamber. <Ref. to IN(H6DO)-7, INSTALLATION, Air Intake Duct.> and <Ref. to IN(H6DO)-5, INSTALLATION, Air Cleaner.> and <Ref. to IN(H6DO)-6, INSTALLATION, Air Intake Chamber.>

25) Connect connector to fuel pump relay.

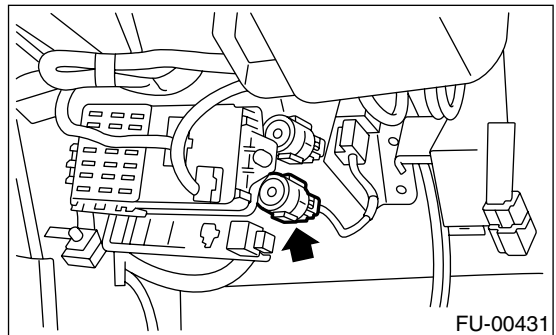

# INTAKE MANIFOLD

## FUEL INJECTION (FUEL SYSTEMS)

26) Connect battery ground cable.

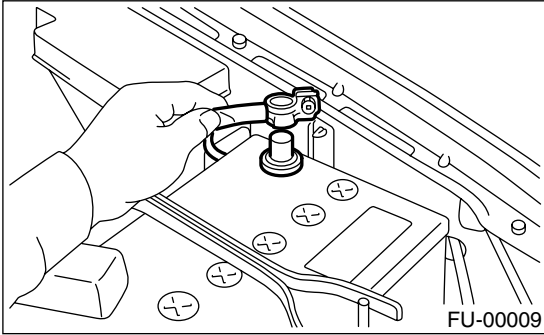

### C: DISASSEMBLY

1) Disconnect connectors from throttle position sensor.

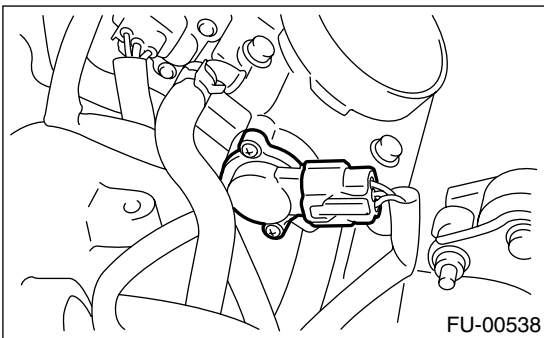

2) Disconnect connectors from intake manifold pressure sensor (A) and idle air control solenoid valve (B).

3) Disconnect air by-pass hose (C) from idle air control solenoid valve.

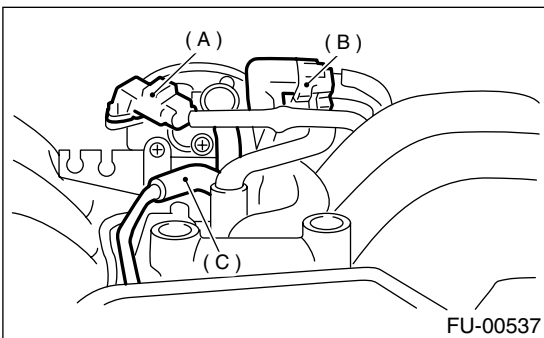

4) Remove throttle body.

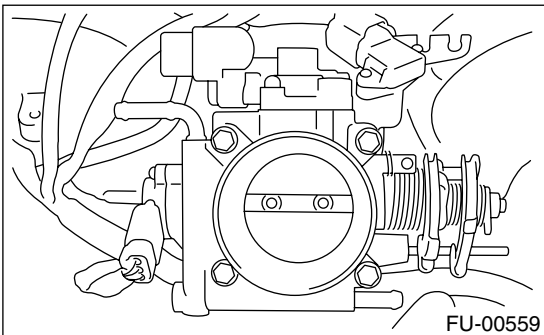

### NOTE:

When removing throttle body, use a new gasket.

5) Disconnect hose which connects induction valve to induction valve control solenoid, then remove.

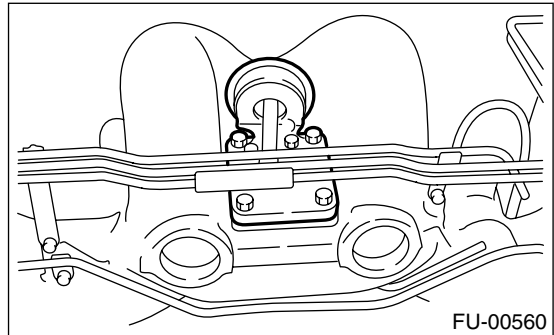

6) Disconnect connector from induction valve control solenoid.

7) Remove induction valve control solenoid.

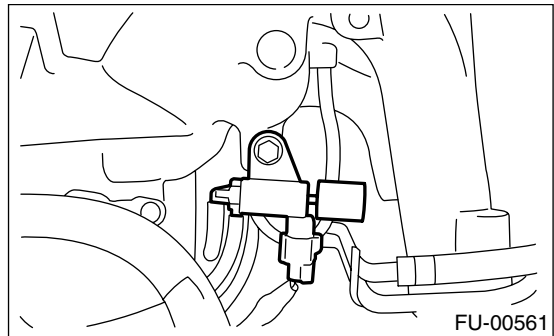

8) Disconnect connector from purge control solenoid valve.

9) Disconnect two hoses between purge control solenoid valve and purge pipe of intake manifold.

10) Remove purge control solenoid valve.

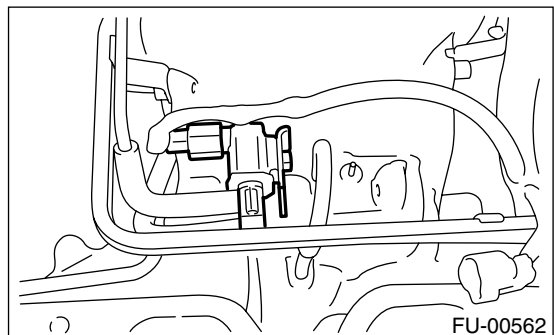

11) Disconnect connector from EGR valve.



# INTAKE MANIFOLD

## FUEL INJECTION (FUEL SYSTEMS)

12) Remove EGR valve.

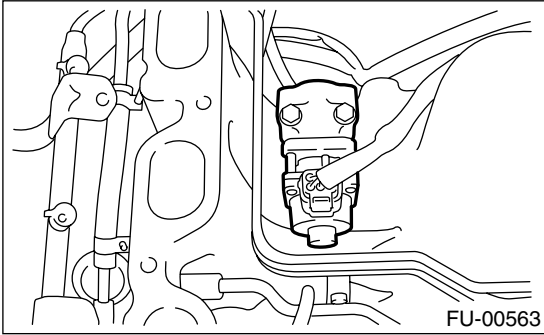

13) Remove engine harness assembly from intake manifold.

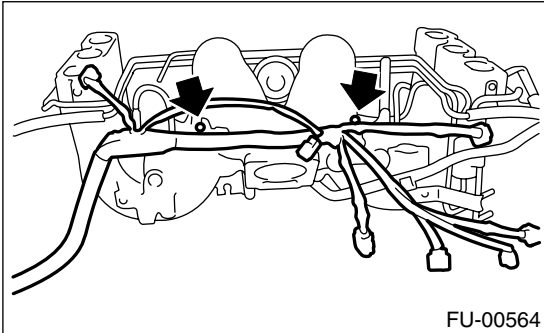

14) Remove PCV pipe from intake manifold.

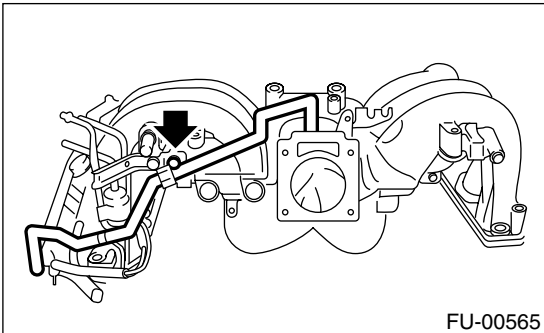

15) Remove air assist and purge pipe assembly.

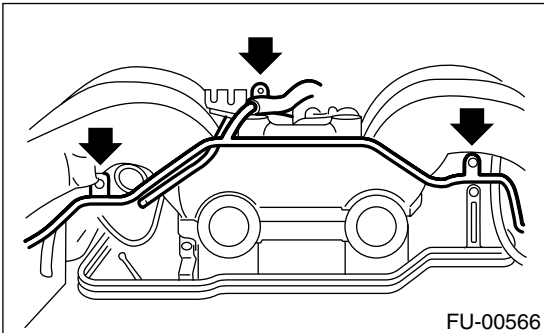

16) Disconnect pressure regulator vacuum hose (A) from intake manifold.

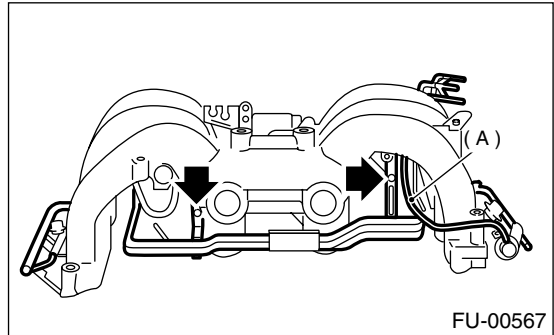

17) Remove fuel pipe and injector pipe assembly.

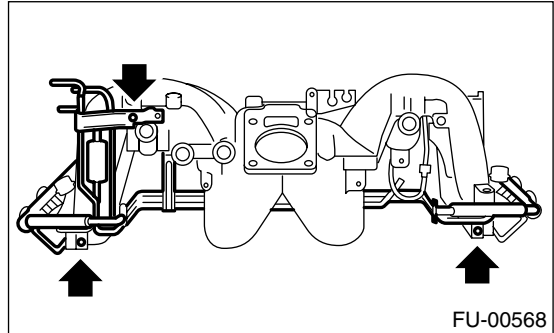

18) Remove induction valve vacuum hose from intake manifold.

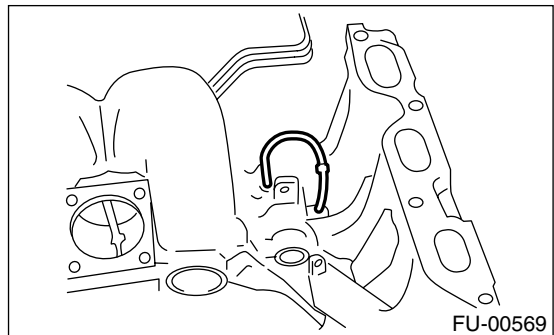

# INTAKE MANIFOLD

## FUEL INJECTION (FUEL SYSTEMS)

### D: ASSEMBLY

1) Intake induction valve vacuum hose to intake manifold.

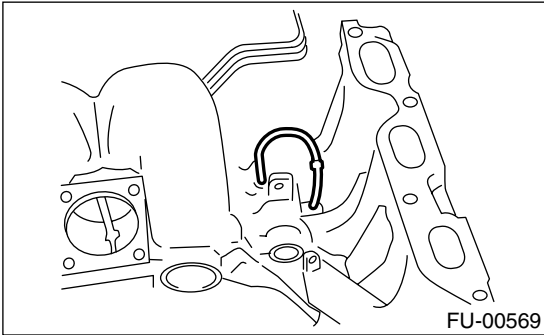

2) Install fuel pipe and injector pipe assembly.

**Tightening torque:**

**5.0 N·m (0.51 kgf-m, 3.7 ft-lb)**

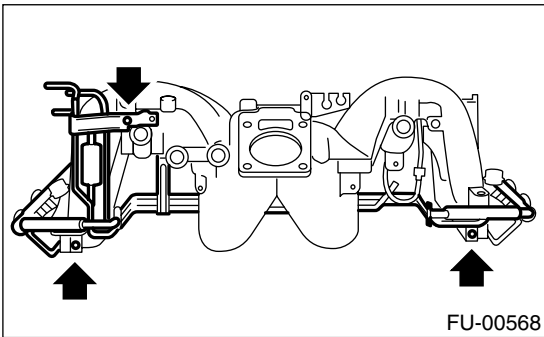

3) Connect pressure regulator vacuum hose (A) to intake manifold.

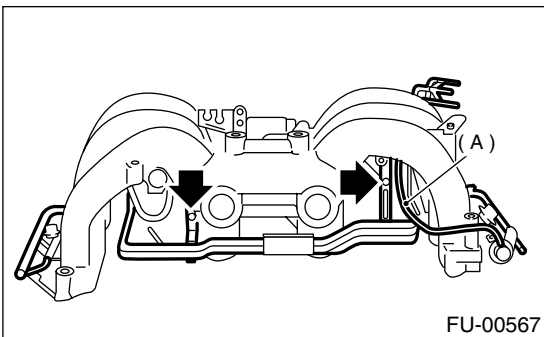

4) Install air assist and purge pipe assembly.

**Tightening torque:**

**5.0 N·m (0.51 kgf-m, 3.7 ft-lb)**

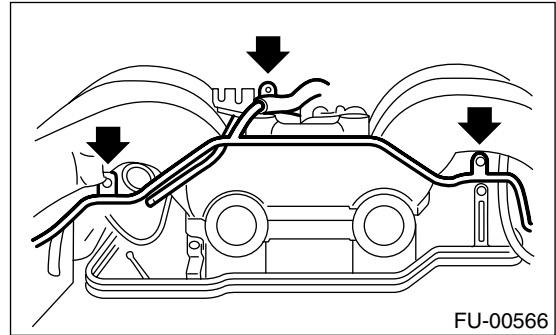

5) Install PCV pipe to intake manifold.

**Tightening torque:**

**6.4 N·m (0.65 kgf-m, 4.7 ft-lb)**

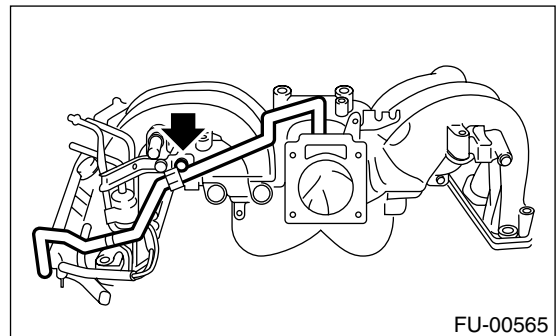

6) Install engine harness assembly to intake manifold.

**Tightening torque:**

**5.0 N·m (0.51 kgf-m, 3.7 ft-lb)**

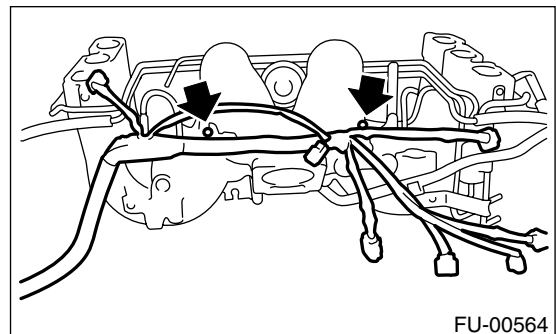

7) Install EGR valve.

**Tightening torque:**

**19 N·m (1.9 kgf-m, 14 ft-lb)**

NOTE:

When removing EGR valve, use a new gasket.

# INTAKE MANIFOLD

## FUEL INJECTION (FUEL SYSTEMS)

8) Connect connector to EGR valve.

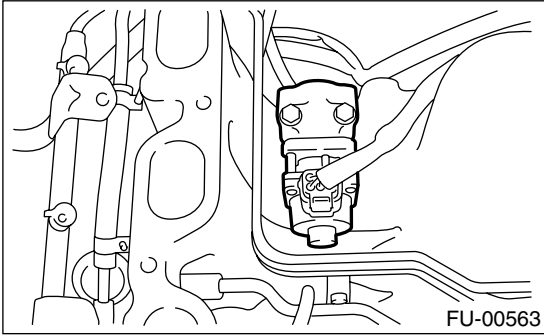

9) Install purge control solenoid valve.

**Tightening torque:**

**19 N·m (1.9 kgf-m, 14 ft-lb)**

10) Connect connector to purge control solenoid valve.

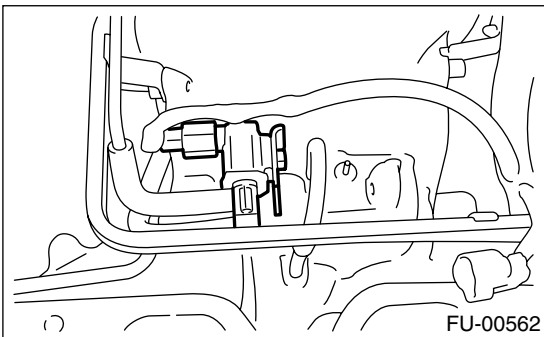

11) Connect hoses to purge control solenoid valve.

**CAUTION:**

**Carefully connect the evaporation hoses.**

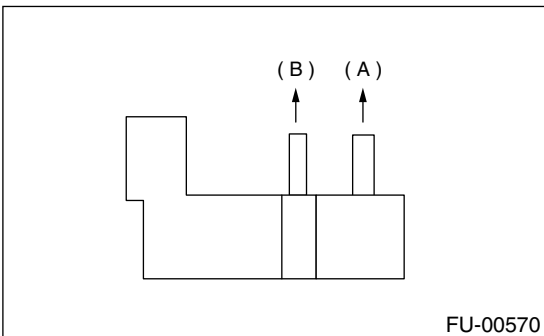

(A) To purge pipe

(B) To fuel pipe

12) Install induction valve control solenoid.

**Tightening torque:**

**19 N·m (1.9 kgf-m, 14 ft-lb)**

13) Connect connector to induction valve control solenoid.

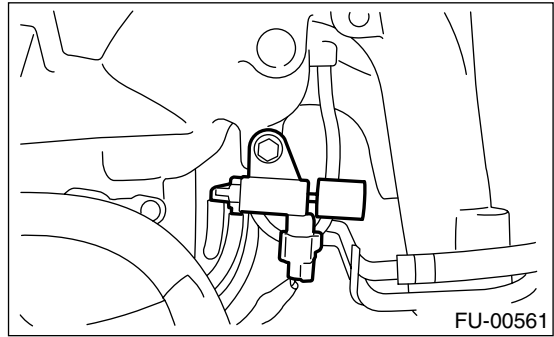

14) Install induction valve.

**Tightening torque:**

**19 N·m (1.9 kgf-m, 14 ft-lb)**

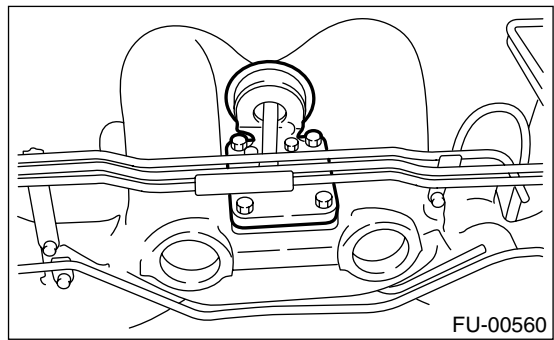

15) Connect hoses to induction valve control solenoid.

**CAUTION:**

**Carefully connect the vacuum hoses.**

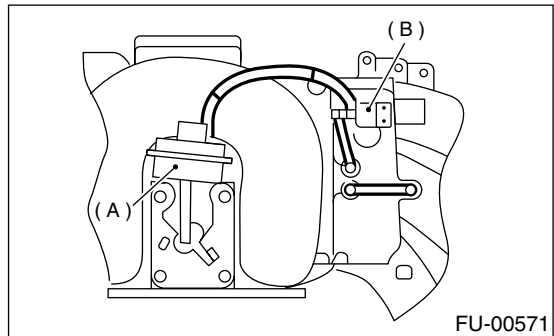

(A) Induction valve

(B) Induction valve control solenoid

# INTAKE MANIFOLD

## FUEL INJECTION (FUEL SYSTEMS)

---

16) Install throttle body to intake manifold.

**NOTE:**

When removing throttle body, replace gasket with new one.

**Tightening torque:**

**22 N·m (2.2 kgf-m, 15.9 ft-lb)**

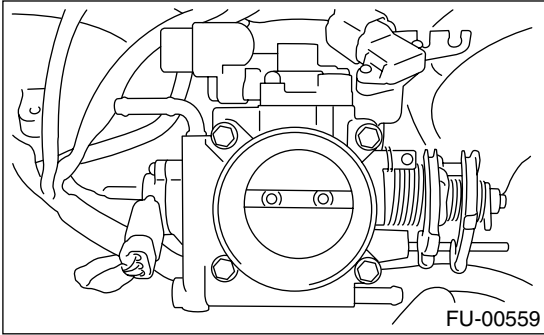

17) Connect connectors to throttle position sensor.

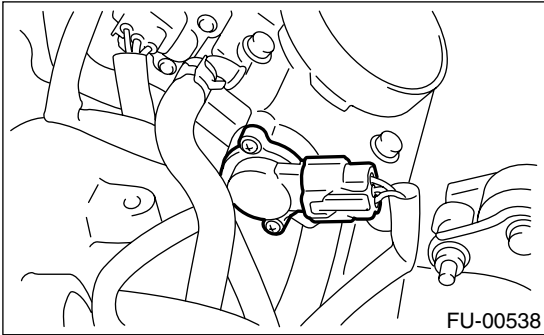

18) Connect connectors to intake manifold pressure sensor (A) and idle air control solenoid valve (B).

19) Connect air by-pass hose (C) to idle air control solenoid valve.

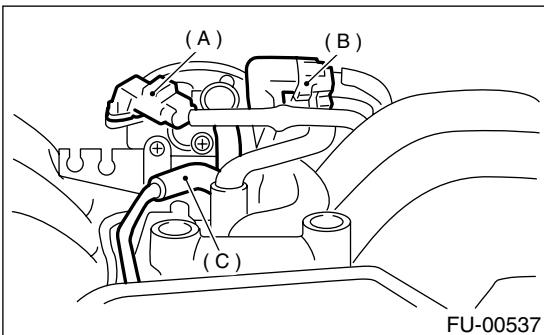

# ENGINE COOLANT TEMPERATURE SENSOR

FUEL INJECTION (FUEL SYSTEMS)

## 4. Engine Coolant Temperature Sensor

### A: REMOVAL

- 1) Disconnect ground cable from battery.

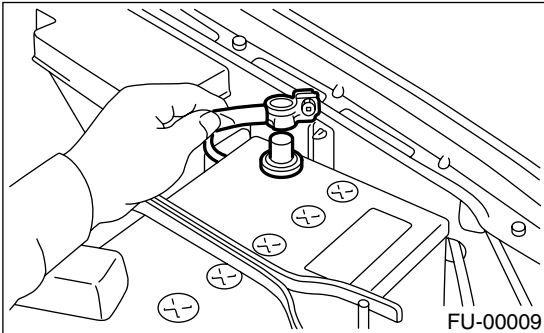

- 2) Disconnect connector from engine coolant temperature sensor.
- 3) Remove engine coolant temperature sensor.

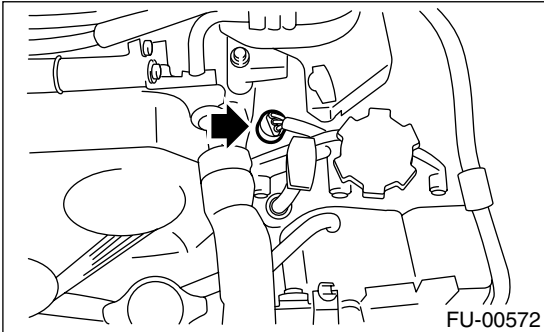

### B: INSTALLATION

Install in the reverse order of removal.

**Tightening torque:**

**16 N·m (0.16 kgf-m, 1.2 ft-lb)**

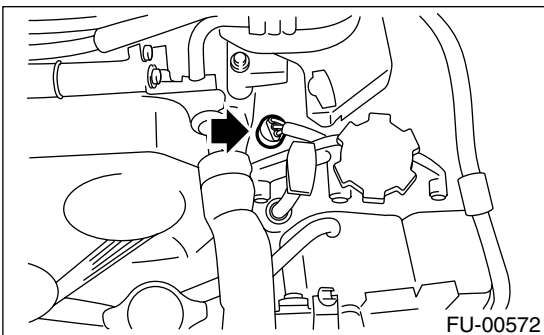

# CRANKSHAFT POSITION SENSOR

FUEL INJECTION (FUEL SYSTEMS)

## 5. Crankshaft Position Sensor

### A: REMOVAL

1) Disconnect ground cable from battery.

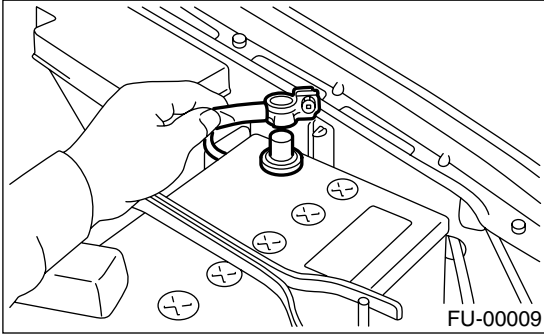

2) Remove air intake chamber.  
<Ref. to IN(H6DO)-6, REMOVAL, Air Intake Chamber.>

3) Remove engine harness bracket from intake manifold.

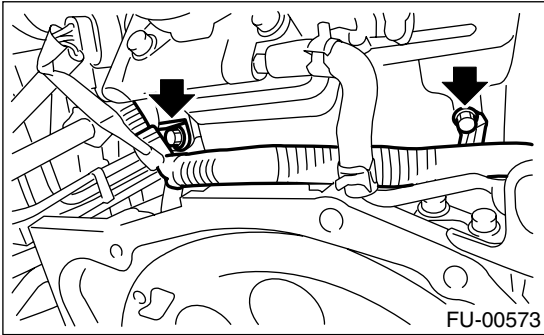

4) Remove service hole cover.

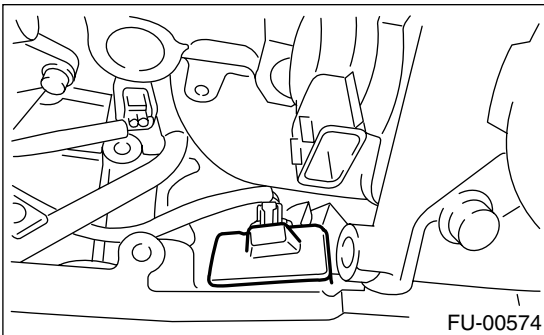

5) Remove bolt which install crankshaft position sensor to cylinder block.

6) Remove crankshaft position sensor, and disconnect connector from it.

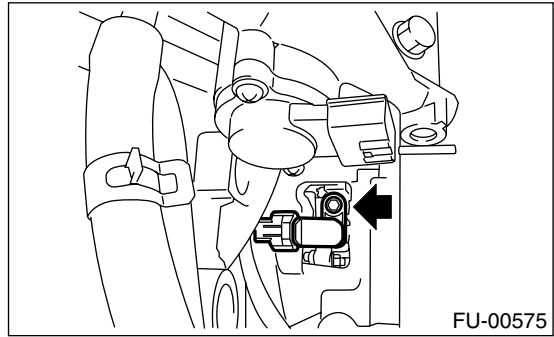

### B: INSTALLATION

Install in the reverse order of removal.

**Tightening torque:**

**6.4 N·m (0.65 kgf-m, 4.7 ft-lb)**

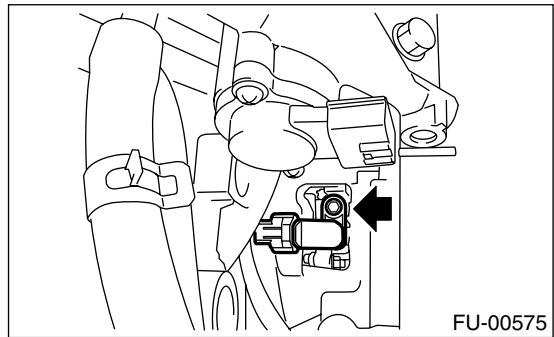

**Tightening torque:**

**5.0 N·m (0.51 kgf-m, 3.7 ft-lb)**

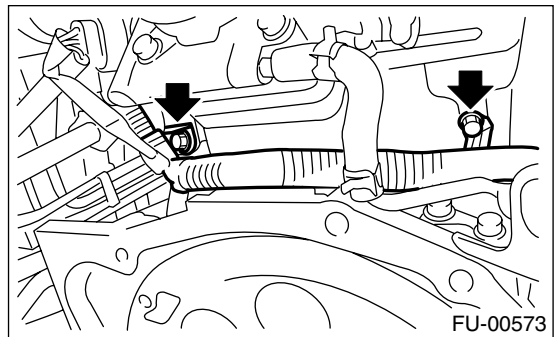

# CAMSHAFT POSITION SENSOR

FUEL INJECTION (FUEL SYSTEMS)

## 6. Camshaft Position Sensor

### A: REMOVAL

1) Disconnect ground cable from battery.

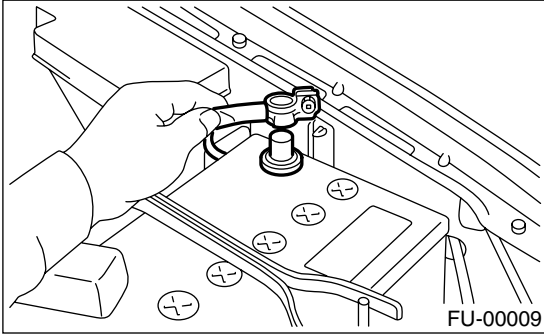

2) Remove ground cable from fuel pipe protector RH.

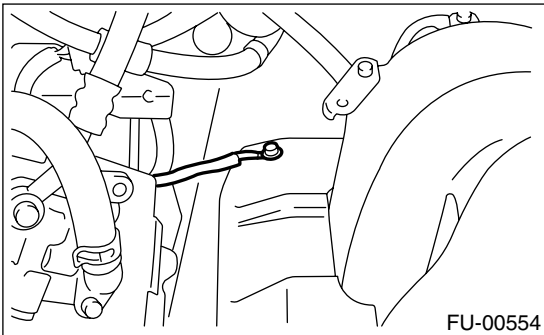

3) Remove fuel pipe protector RH.

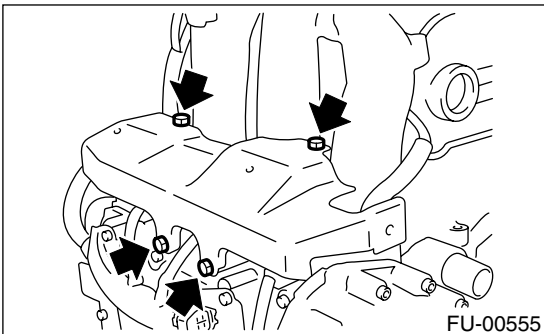

4) Disconnect connector from camshaft position sensor.

5) Remove camshaft position sensor.

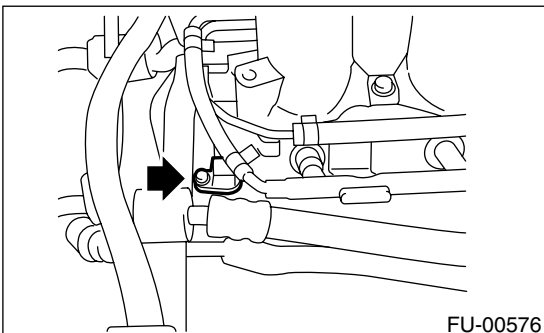

### B: INSTALLATION

Install in the reverse order of removal.

**Tightening torque:**

- **Camshaft position sensor;**  
**6.4 N·m (0.65 kgf-m, 4.7 ft-lb)**
- **Fuel pipe protector RH;**  
**19 N·m (1.9 kgf-m, 14 ft-lb)**

# KNOCK SENSOR

FUEL INJECTION (FUEL SYSTEMS)

## 7. Knock Sensor

### A: REMOVAL

1) Disconnect ground cable from battery.

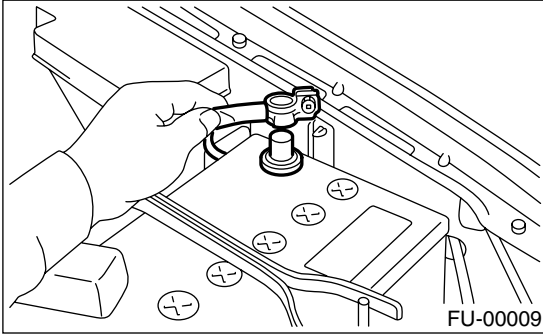

4) Connect battery ground cable.

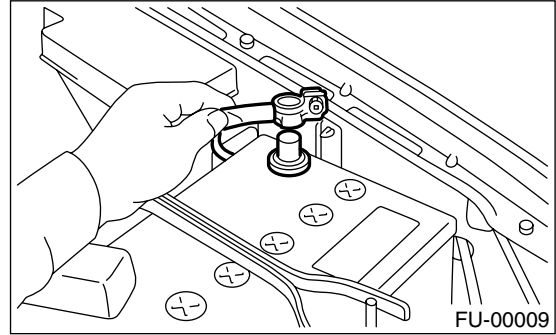

2) Remove intake manifold.

<Ref. to FU(H6DO)-17, REMOVAL, Intake Manifold.>

3) Disconnect knock sensor connector.

4) Remove knock sensor from cylinder block.

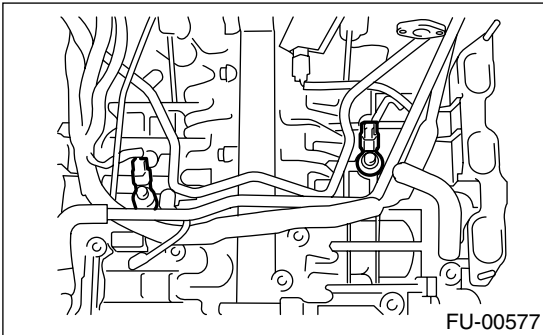

### B: INSTALLATION

1) Install knock sensor to cylinder block.

**Tightening torque:**

**25 N·m (2.5 kgf·m, 18 ft·lb)**

**NOTE:**

For the knock sensor's installation angle, refer to the figure below.

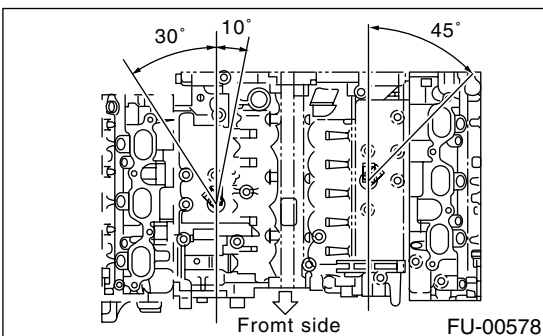

2) Connect knock sensor connector.

3) Install intake manifold. <Ref. to FU(H6DO)-20, INSTALLATION, Intake Manifold.>



# THROTTLE POSITION SENSOR

FUEL INJECTION (FUEL SYSTEMS)

## 8. Throttle Position Sensor

### A: REMOVAL

- 1) Disconnect ground cable from battery.

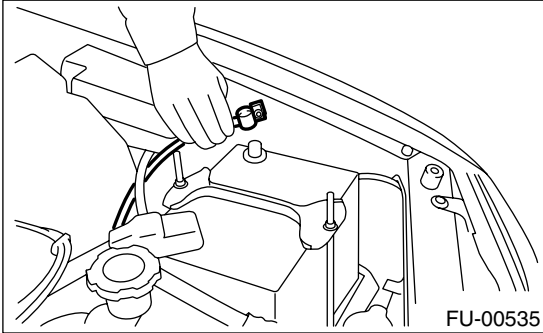

Remove air intake chamber. <Ref. to IN(H6DO)-6, REMOVAL, Air Intake Chamber.>

- 2) Disconnect connector from throttle position sensor.
- 3) Remove throttle position sensor holding screws, and remove throttle position sensor.

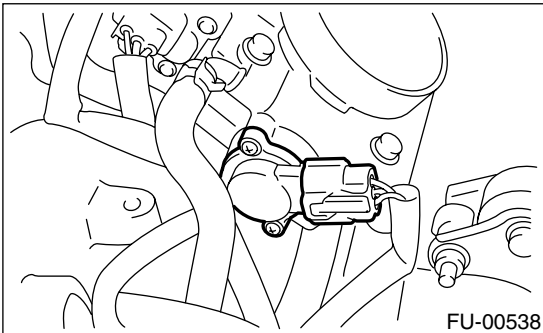

### B: INSTALLATION

Install in the reverse order of removal.

#### **Tightening torque:**

**1.6 N·m (0.16 kgf·m, 1.2 ft·lb)**

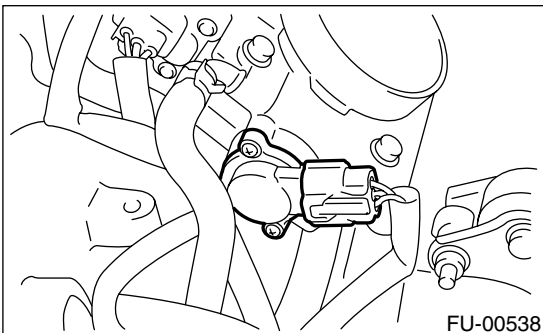

# INTAKE MANIFOLD PRESSURE SENSOR

FUEL INJECTION (FUEL SYSTEMS)

---

## 9. Intake Manifold Pressure Sensor

### A: REMOVAL

- 1) Disconnect ground cable from battery.

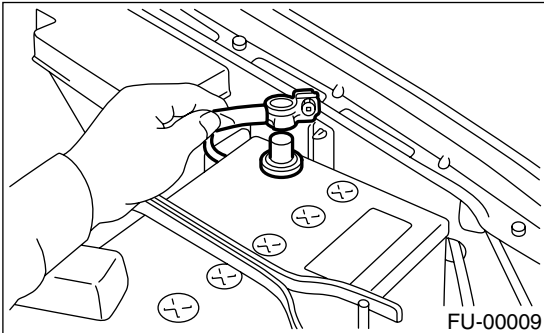

- 2) Disconnect connector from intake manifold pressure sensor.
- 3) Remove intake manifold pressure sensor from throttle body.

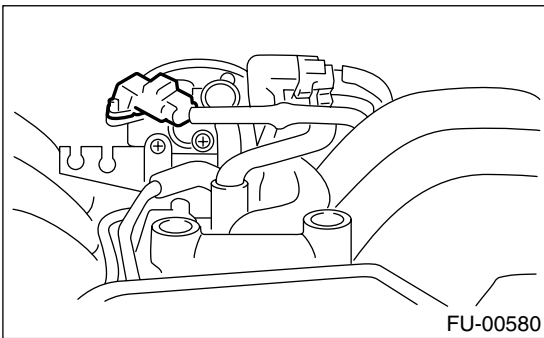

### B: INSTALLATION

Install in the reverse order of removal.

#### NOTE:

When removing intake manifold pressure sensor, replace O-ring with new one.

#### *Tightening torque:*

**1.6 N·m (0.16 kgf·m, 1.2 ft·lb)**

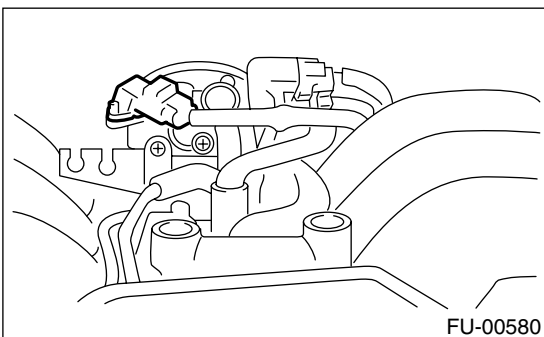

# INTAKE AIR TEMPERATURE SENSOR

FUEL INJECTION (FUEL SYSTEMS)

## 10. Intake Air Temperature Sensor

### A: REMOVAL

- 1) Disconnect ground cable from battery.

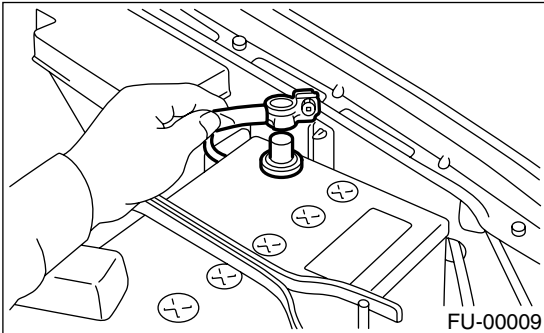

- 2) Disconnect connector from intake air temperature sensor.
- 3) Remove intake air temperature sensor from air intake chamber.

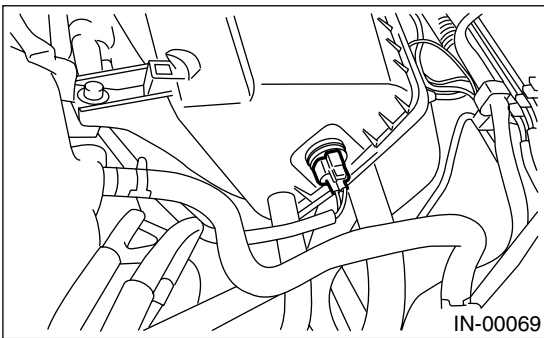

### B: INSTALLATION

Install in the reverse order of removal.

# IDLE AIR CONTROL SOLENOID VALVE

FUEL INJECTION (FUEL SYSTEMS)

---

## 11. Idle Air Control Solenoid Valve

### A: REMOVAL

- 1) Disconnect ground cable from battery.

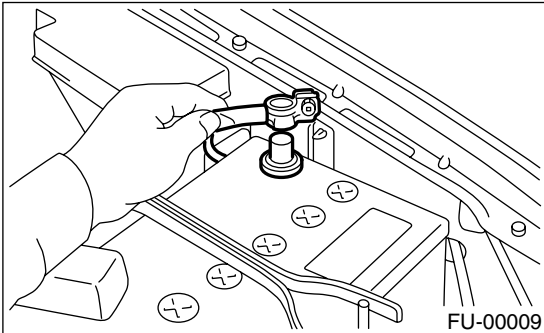

- 2) Disconnect connector (A) from idle air control solenoid valve.
- 3) Disconnect air by-pass hose (B) from idle air control solenoid valve.
- 4) Remove idle air control solenoid valve from throttle body.

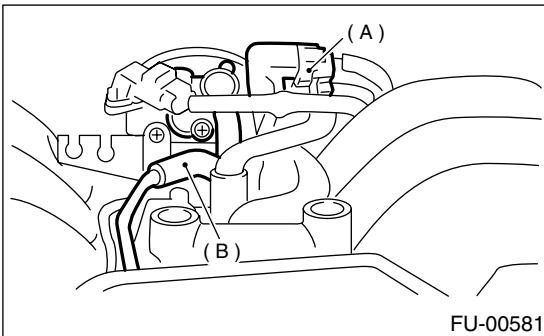

### B: INSTALLATION

Install in the reverse order of removal.

#### NOTE:

When removing idle air control solenoid valve, replace gasket with new one.

#### **Tightening torque:**

**2.8 N·m (0.29 kgf-m, 2.1 ft-lb)**

## 12. Induction Valve

### A: REMOVAL

- 1) Disconnect ground cable from battery.
- 2) Remove intake manifold.  
<Ref. to FU(H6DO)-17, REMOVAL, Intake Manifold.>
- 3) Remove induction valve from intake manifold.

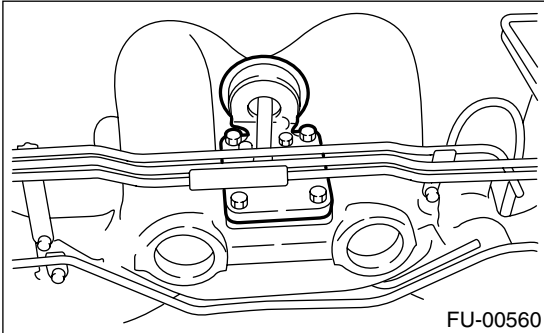

### B: INSTALLATION

Install in the reverse order of removal.

#### NOTE:

When removing induction valve, replace gasket with new one.

#### **Tightening torque:**

**19 N·m (1.9 kgf-m, 14 ft-lb)**

# INDUCTION VALVE CONTROL SOLENOID

FUEL INJECTION (FUEL SYSTEMS)

---

## 13. Induction Valve Control Solenoid

### A: REMOVAL

- 1) Disconnect ground cable from battery.
- 2) Remove intake manifold.  
<Ref. to FU(H6DO)-17, REMOVAL, Intake Manifold.>
- 3) Disconnect hose which connects induction valve to induction valve control solenoid.
- 4) Disconnect connector from induction valve control solenoid.
- 5) Remove induction valve control solenoid from intake manifold.

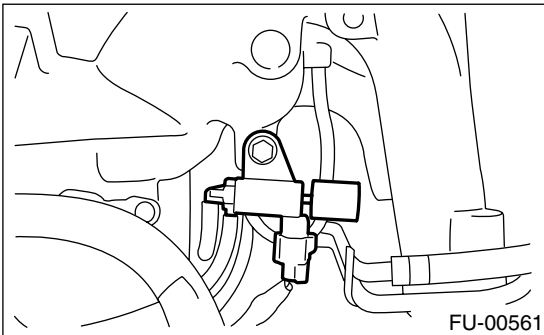

### B: INSTALLATION

Install in the reverse order of removal.

#### NOTE:

When removing induction valve control solenoid, replace gasket with new one.

#### *Tightening torque:*

**19 N·m (1.9 kgf-m, 14 ft-lb)**

## 14. Fuel Injector

### A: REMOVAL

#### 1. RH SIDE

- 1) Release fuel pressure.  
<Ref. to FU(H6DO)-50, RELEASING OF FUEL PRESSURE, OPERATION, Fuel.>
- 2) Open fuel flap lid, and remove fuel filler cap.
- 3) Disconnect ground cable from battery.

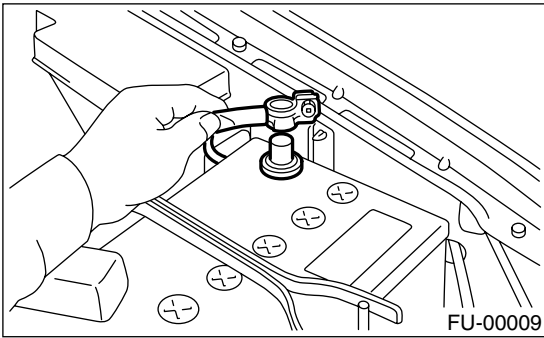

- 4) Remove air cleaner lower case. <Ref. to IN(H6DO)-5, REMOVAL, Air Cleaner.>
- 5) Remove power steering pump and tank from brackets.
  - (1) Remove V-belt.  
<Ref. to ME(H6DO)-28, REMOVAL, V-belt.>
  - (2) Remove power steering oil pipe with bracket.

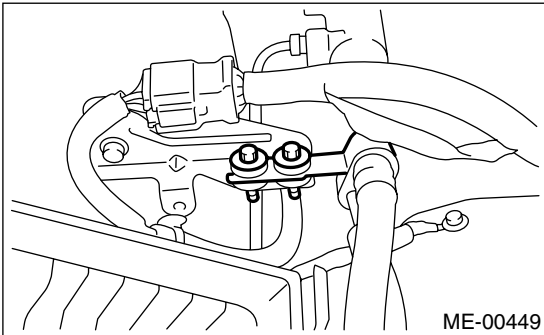

- (3) Remove bolts which install power steering pump bracket.

#### CAUTION:

Do not disconnect power steering hose.

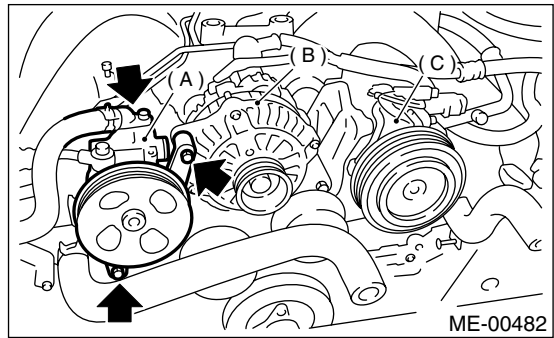

- (A) Power steering pump
- (B) Generator
- (C) A/C compressor

- (4) Disconnect power steering pump switch connector.

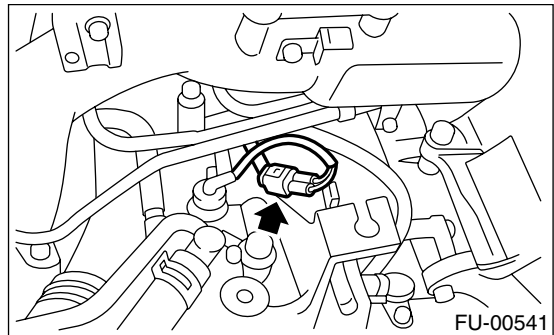

- (5) Remove power steering tank from the bracket by pulling it upward.

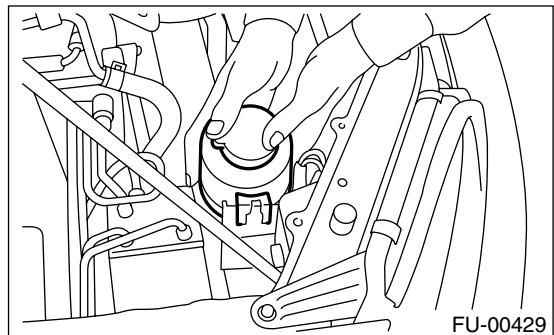

# FUEL INJECTOR

## FUEL INJECTION (FUEL SYSTEMS)

(6) Place power steering pump on the right side wheel apron.

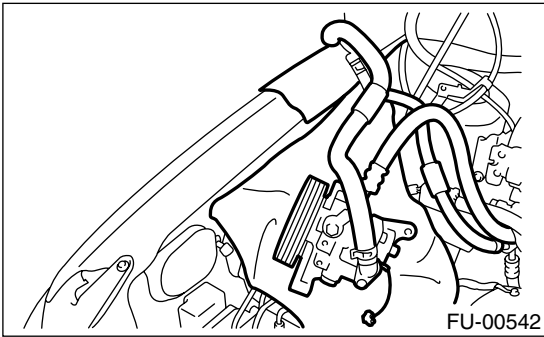

6) Remove ground cable from fuel pipe protector RH.

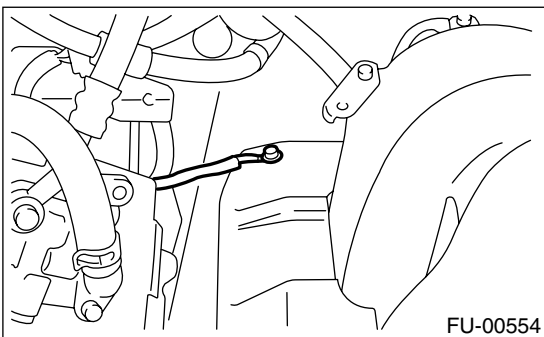

7) Remove fuel pipe protector RH.

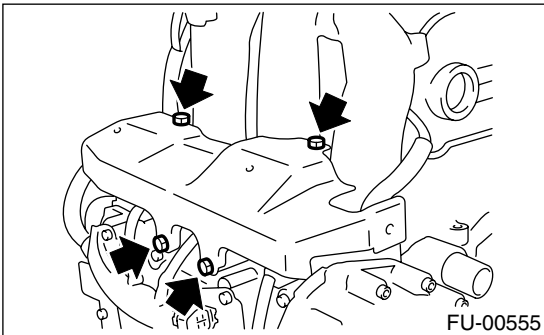

8) Disconnect connector (A) from fuel injector.

9) Remove bolt (B) which holds injector pipe onto cylinder head.

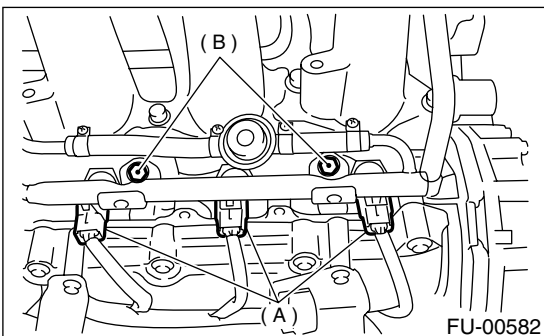

10) Remove fuel injector while lifting up fuel injector pipe.

## 2. LH SIDE

1) Release fuel pressure. <Ref. to FU(H6DO)-50, RELEASING OF FUEL PRESSURE, OPERATION, Fuel.>

2) Open fuel flap lid, and remove fuel filler cap.

3) Disconnect ground cable from battery.

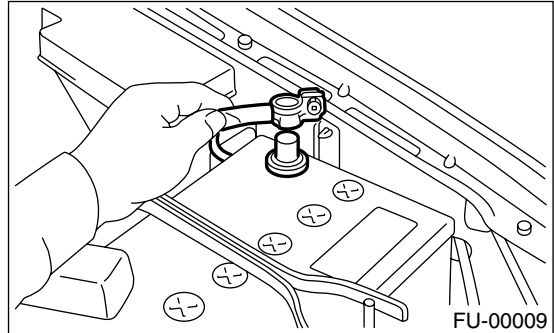

4) Remove two bolts which install washer tank on body.

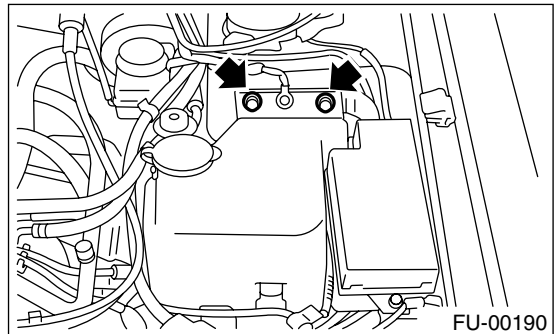

5) Disconnect connector from front window washer motor.

6) Disconnect connector from rear gate glass washer motor.

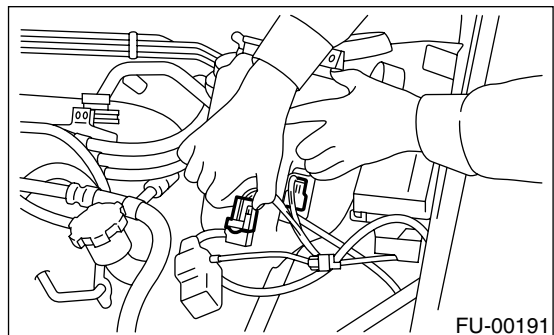

7) Disconnect rear window glass washer hose from washer motor, then plug connection with a suitable cap.



8) Move washer tank upward.

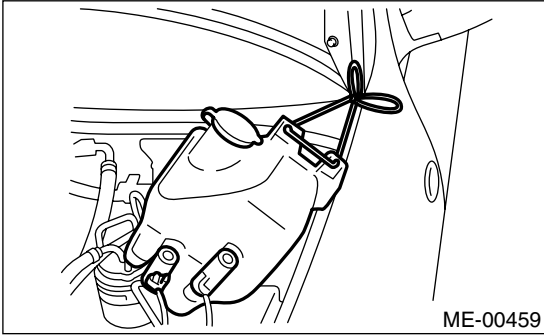

9) Remove ground cable from fuel pipe protector LH.

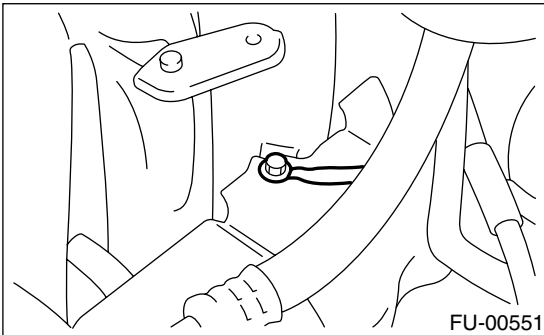

10) Remove fuel pipe protector LH.

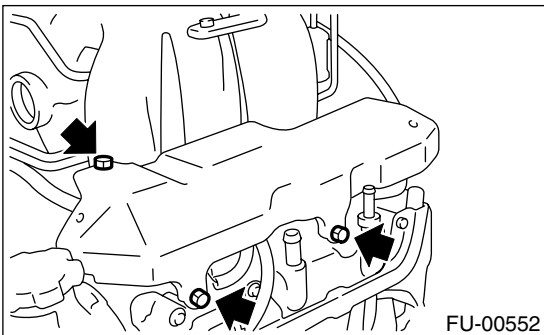

11) Disconnect connector (A) from fuel injector.  
 12) Remove bolt (B) which holds injector pipe onto cylinder head.

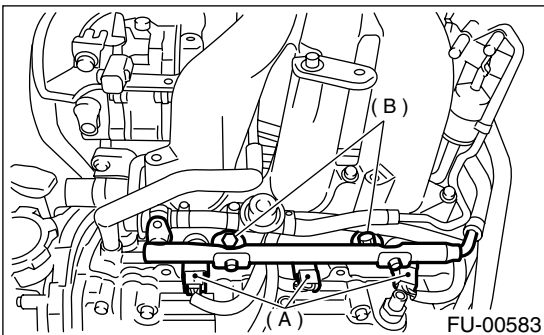

13) Remove fuel injector while lifting up fuel injector pipe.

## B: INSTALLATION

### 1. RH SIDE

Install in the reverse order of removal.

NOTE:

Replace O-rings and insulators with new ones.

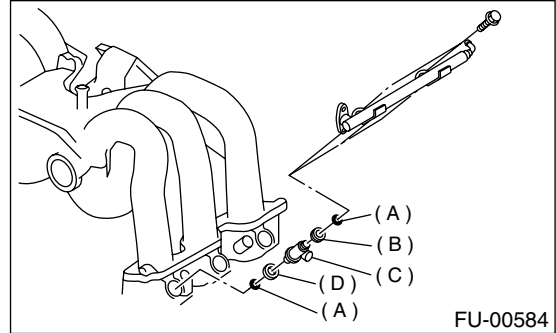

- (A) O-ring
- (B) Injection rubber
- (C) Fuel injector
- (D) Insulator

**Tightening torque:**

**19 N·m (1.9 kgf-m, 14 ft-lb)**

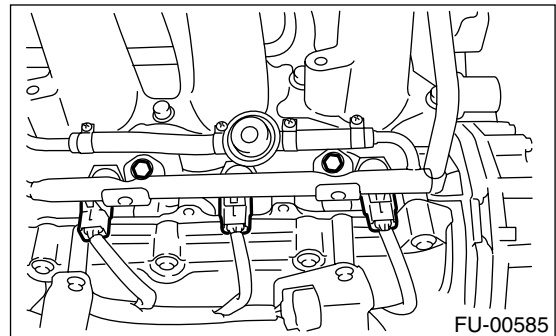

**Tightening torque:**

**19 N·m (1.9 kgf-m, 14 ft-lb)**

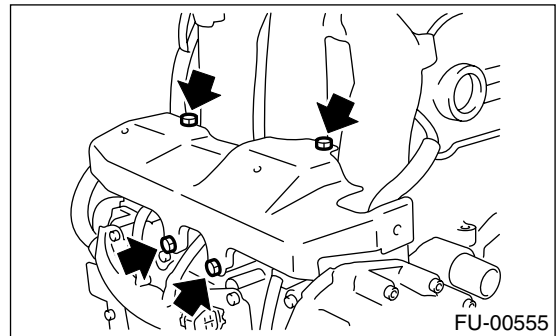

# FUEL INJECTOR

## FUEL INJECTION (FUEL SYSTEMS)

### 2. LH SIDE

Install in the reverse order of removal.

#### NOTE:

Replace O-rings and insulators with new ones.

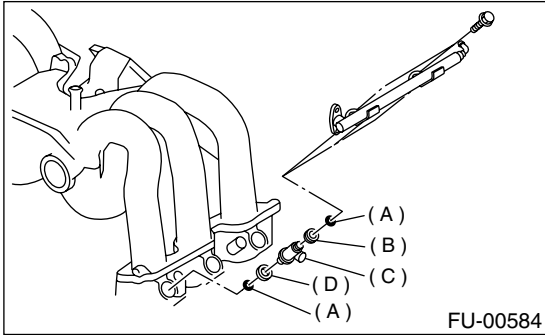

- (A) O-ring
- (B) Injection rubber
- (C) Fuel injector
- (D) Insulator

#### **Tightening torque:**

**19 N·m (1.9 kgf-m, 14 ft-lb)**

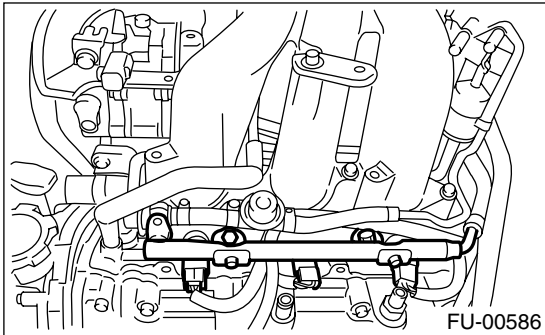

#### **Tightening torque:**

**19 N·m (1.9 kgf-m, 14 ft-lb)**

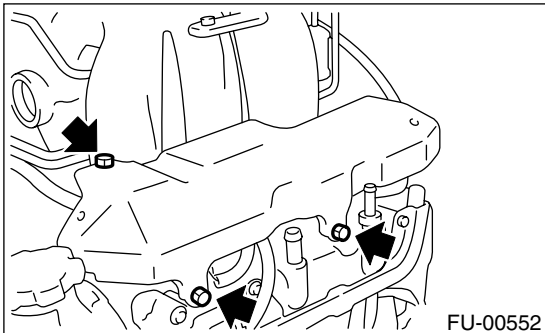

# FRONT OXYGEN (A/F) SENSOR

FUEL INJECTION (FUEL SYSTEMS)

## 15. Front Oxygen (A/F) Sensor

### A: REMOVAL

1) Disconnect ground cable from battery.

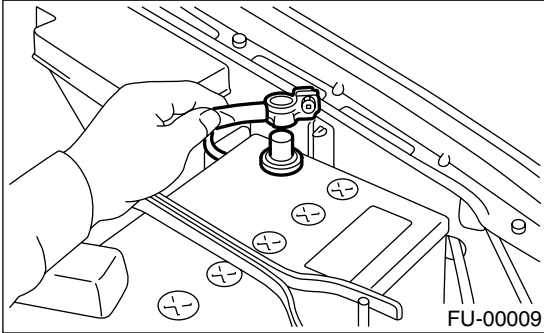

2) Disconnect connector from front oxygen (A/F) sensor.

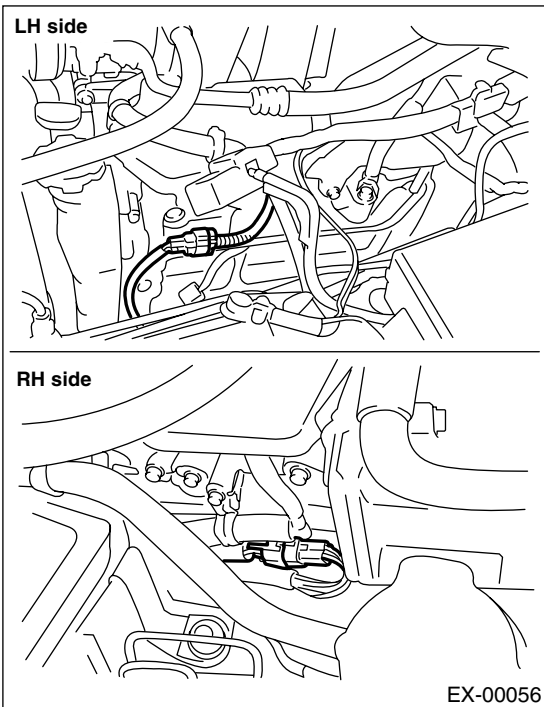

3) Lift-up the vehicle.  
4) Remove undercover.  
5) Separate harness from clip (A).

• LH side

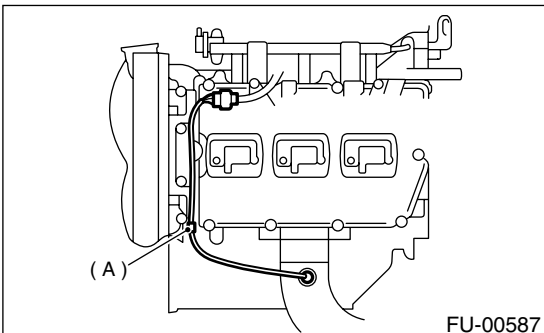

• RH side

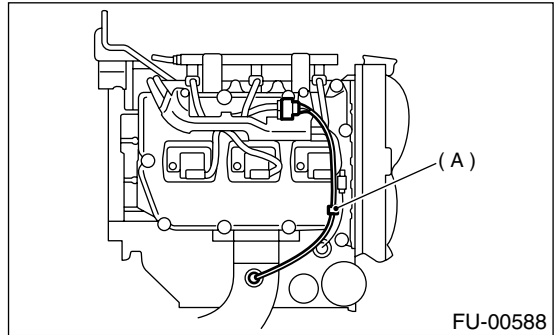

6) Apply SUBARU CRC or its equivalent to threaded portion of front oxygen (A/F) sensor, and leave it for one minute or more.

**SUBARU CRC (Part No. 004301003)**

7) Remove front oxygen (A/F) sensor.

### CAUTION:

When removing the oxygen (A/F) sensor, wait until exhaust pipe cools, otherwise it will damage exhaust pipe.

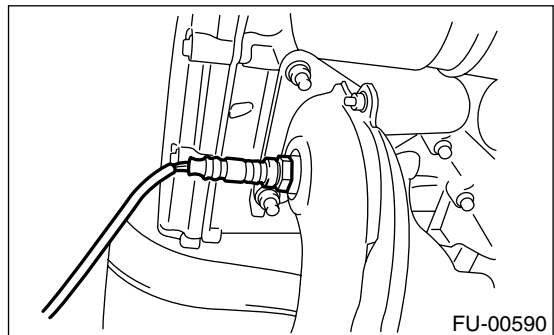
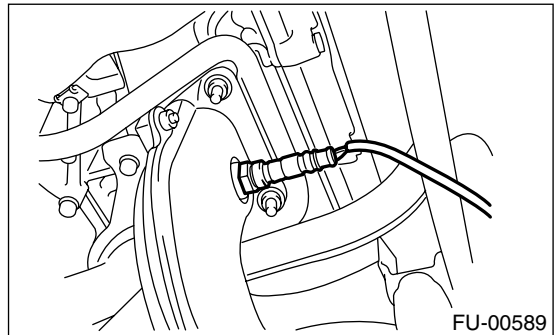

# FRONT OXYGEN (A/F) SENSOR

FUEL INJECTION (FUEL SYSTEMS)

## B: INSTALLATION

1) Before installing front oxygen (A/F) sensor, apply anti-seize compound only to threaded portion of front oxygen (A/F) sensor to make the next removal easier.

**Anti-seize compound:**  
**SS-30 by JET LUBE**

**CAUTION:**  
**Never apply anti-seize compound to protector of front oxygen (A/F) sensor.**

2) Install front oxygen (A/F) sensor.

**Tightening torque:**  
**21 N·m (2.1 kgf-m, 15.2 ft-lb)**

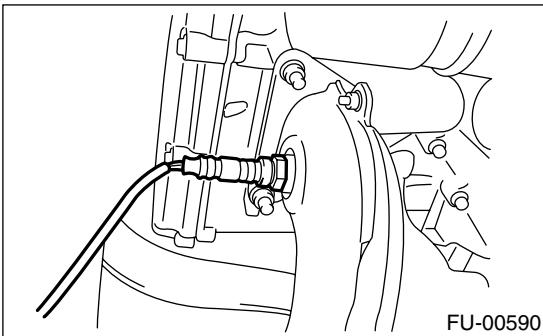
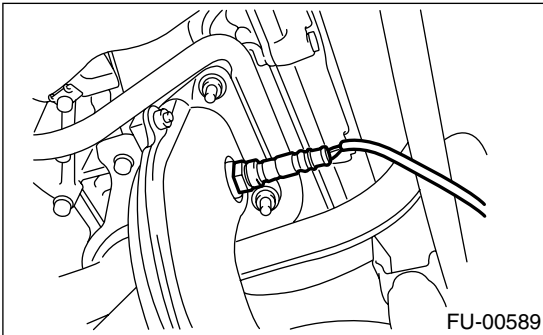

3) Secure harness to clip (A).

- LH side

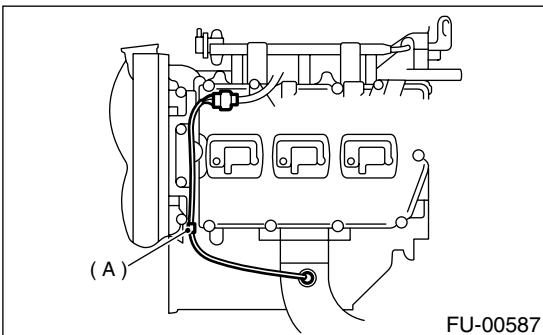

- RH side

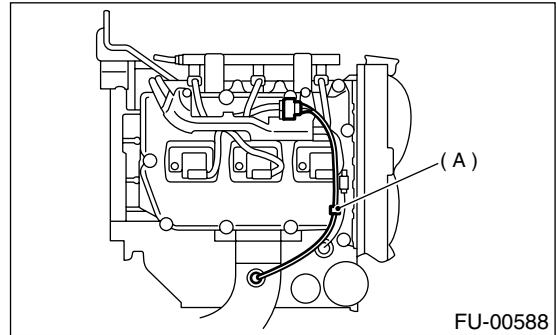

- 4) Install undercover.
- 5) Lower the vehicle.
- 6) Connect connector of front oxygen (A/F) sensor.

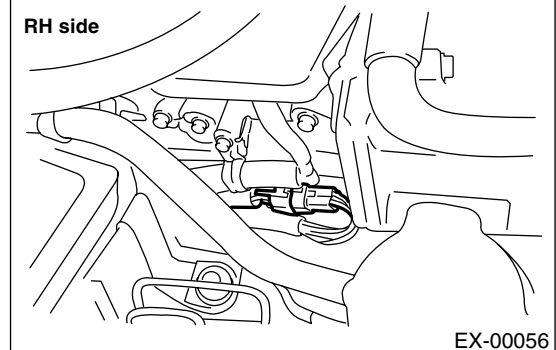
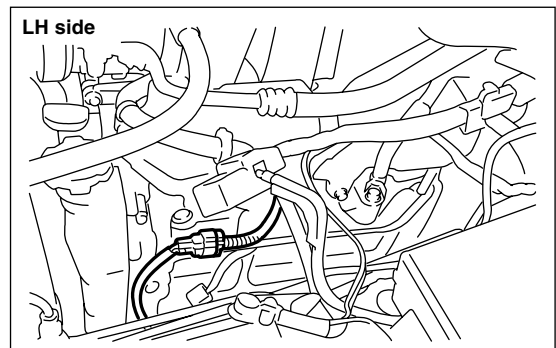

7) Connect battery ground cable.

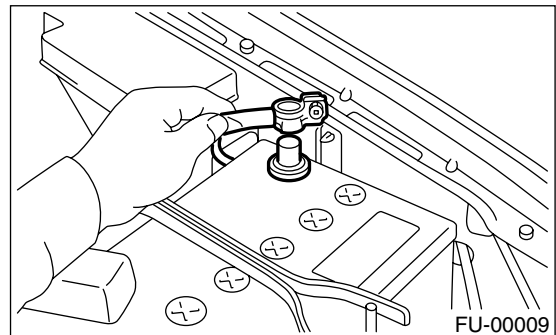

## 16.Rear Oxygen Sensor

### A: REMOVAL

- 1) Disconnect ground cable from battery.

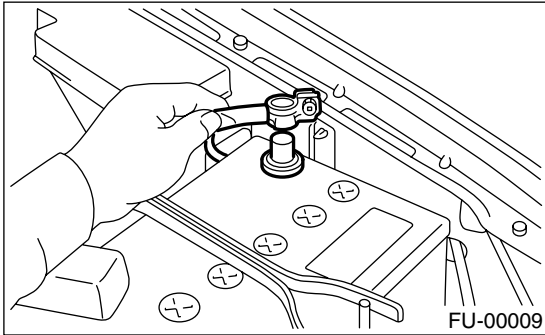

- 2) Disconnect connector from rear oxygen sensor.

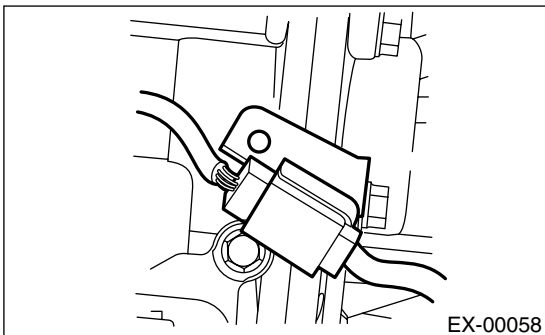

- 3) Lift-up the vehicle.
- 4) Apply SUBARU CRC or its equivalent to threaded portion of rear oxygen sensor, and leave it for one minute or more.

**SUBARU CRC (Part No. 004301003)**

- 5) Remove rear oxygen sensor.

### CAUTION:

**When removing the oxygen (A/F) sensor, wait until exhaust pipe cools, otherwise it will damage exhaust pipe.**

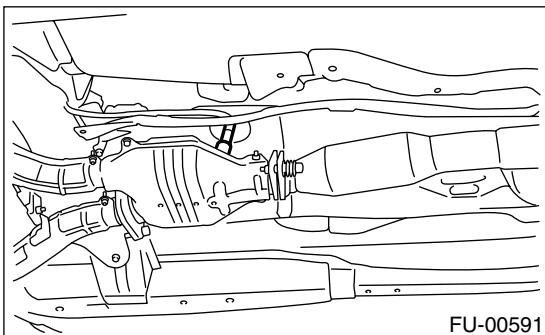

### B: INSTALLATION

- 1) Before installing rear oxygen sensor, apply anti-seize compound only to threaded portion of rear oxygen sensor to make the next removal easier.

### CAUTION:

**Never apply anti-seize compound to protector of rear oxygen sensor.**

### Anti-seize compound:

**SS-30 by JET LUBE**

- 2) Install rear oxygen sensor.

### Tightening torque:

**21 N·m (2.1 kgf-m, 15.2 ft-lb)**

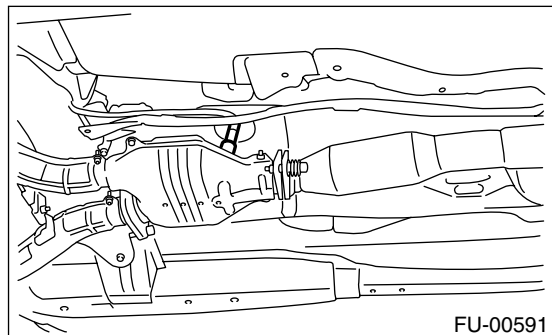

- 3) Connect connector to rear oxygen sensor.

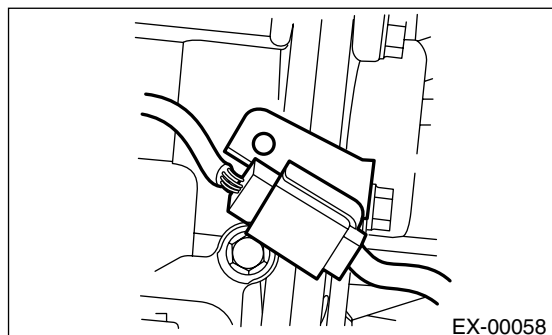

- 4) Lower the vehicle.
- 5) Connect battery ground cable.

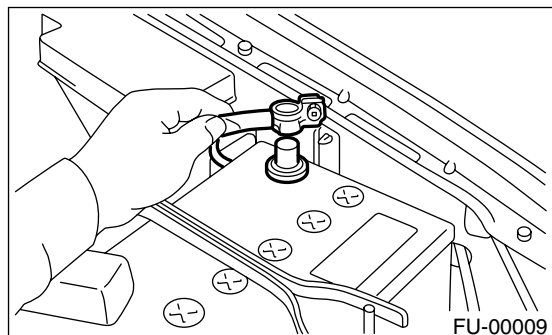

# ENGINE CONTROL MODULE

FUEL INJECTION (FUEL SYSTEMS)

## 17.Engine Control Module

### A: REMOVAL

- 1) Disconnect ground cable from battery.

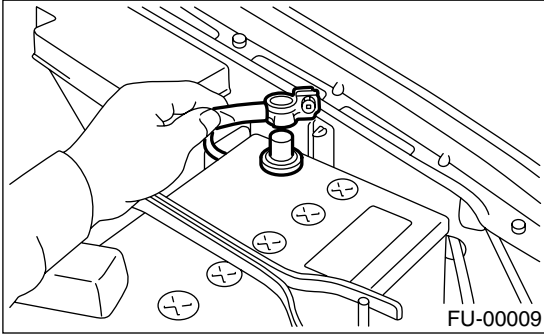

- 2) Remove lower inner trim of passenger side.  
<Ref. to EI-51, REMOVAL, Lower Inner Trim.>
- 3) Detach floor mat of front passenger seat.
- 4) Remove protect cover.

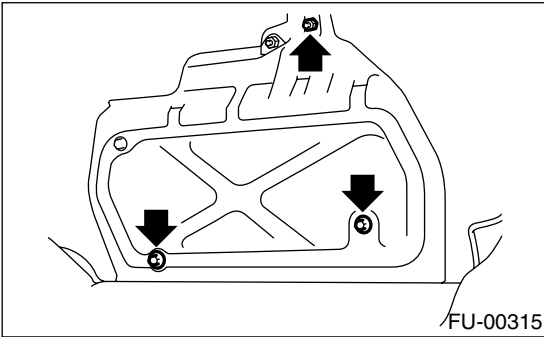

- 5) Remove nuts which hold ECM to bracket.

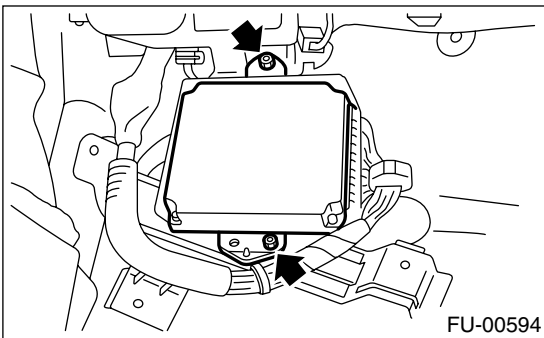

- 6) Remove clip from bracket.

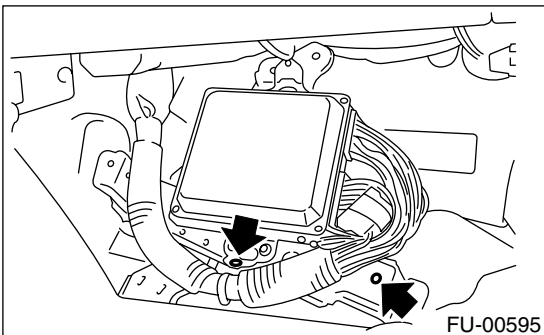

- 7) Disconnect ECM connectors and take out ECM.

### B: INSTALLATION

Install in the reverse order of removal.

#### CAUTION:

When replacing ECM, be careful not to use the wrong spec. ECM to avoid any damage to the fuel injection system.

*Tightening torque:*

*5 N·m (0.51 kgf-m, 3.7 ft-lb)*

### 18.Main Relay

#### A: REMOVAL

1) Disconnect ground cable from battery.

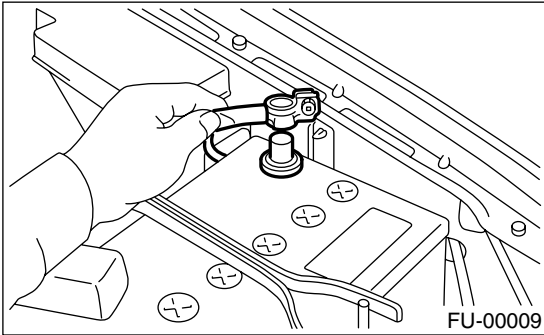

2) Remove lower inner trim of passenger side.

<Ref. to EI-51, REMOVAL, Lower Inner Trim.>

3) Disconnect connectors from main relay.

4) Remove bolt which holds main relay bracket on body.

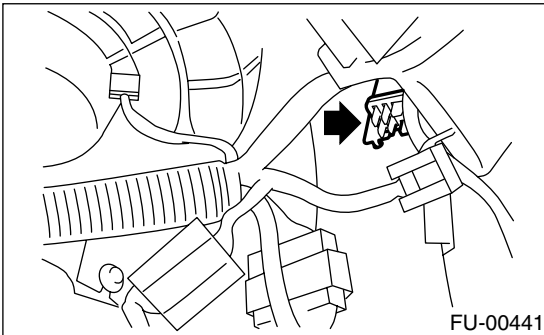

#### B: INSTALLATION

Install in the reverse order of removal.

# FUEL PUMP RELAY

FUEL INJECTION (FUEL SYSTEMS)

---

## 19. Fuel Pump Relay

### A: REMOVAL

1) Disconnect ground cable from battery.

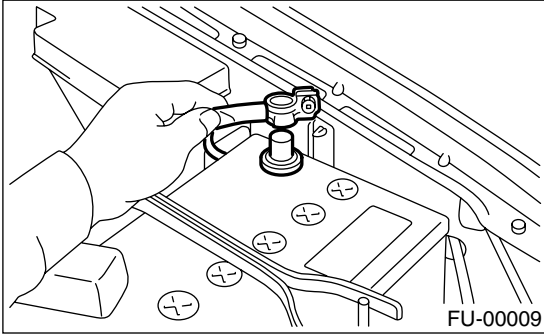

2) Remove lower cover. <Ref. to EI-46, REMOVAL, Instrument Panel Assembly.>

3) Disconnect connector from fuel pump relay.

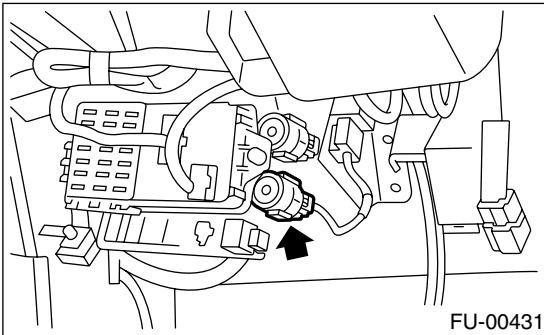

4) Remove fuel pump relay from mounting bracket.

### B: INSTALLATION

Install in the reverse order of removal.



## 20. Fuel Pump Controller

### A: REMOVAL

- 1) Disconnect ground cable from battery.

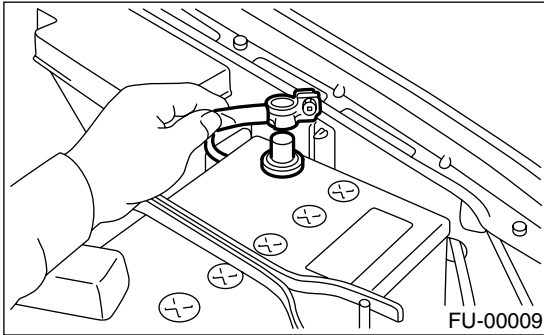

- 2) Remove rear quarter trim. <Ref. to EI-52, REMOVAL, Rear Quarter Trim.>

- 3) Disconnect connector from fuel pump control unit.

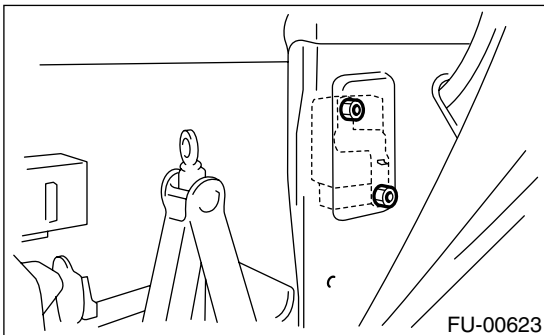

- 4) Remove connector of fuel pump control unit.

### B: INSTALLATION

Install in the reverse order of removal.

# FUEL

## FUEL INJECTION (FUEL SYSTEMS)

### 21. Fuel

#### A: OPERATION

##### 1. RELEASING OF FUEL PRESSURE

###### WARNING:

- Place “NO FIRE” signs near the working area.
- Be careful not to spill fuel on the floor.

- 1) Disconnect connector from fuel pump relay.

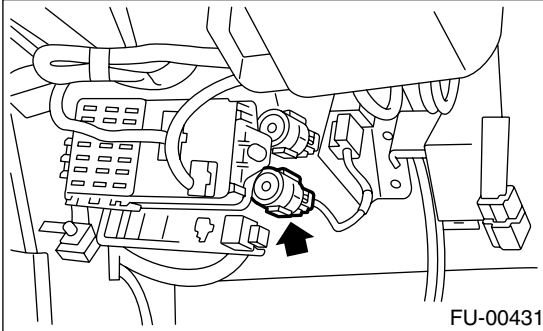

- 2) Start the engine and run it until it stalls.
- 3) After the engine stalls, crank it for five more seconds.
- 4) Turn ignition switch to OFF.

##### 2. DRAINING FUEL

###### WARNING:

- Place “NO FIRE” signs near the working area.
- Be careful not to spill fuel on the floor.

- 1) Set vehicle on the lift.
- 2) Disconnect ground cable from battery.

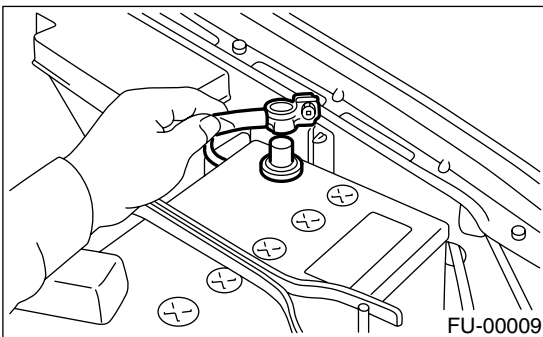

- 3) Lift-up the vehicle.
- 4) Remove front right side fuel tank cover.

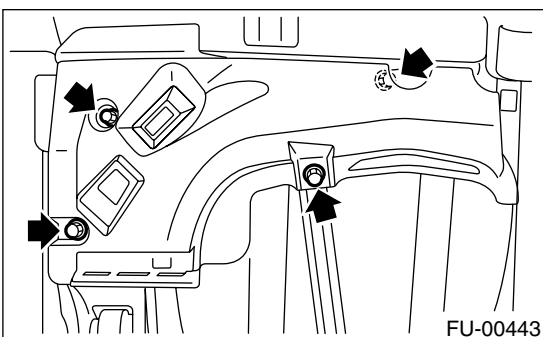

- 5) Drain fuel from fuel tank.

Set a container under the vehicle and remove drain plug from fuel tank.

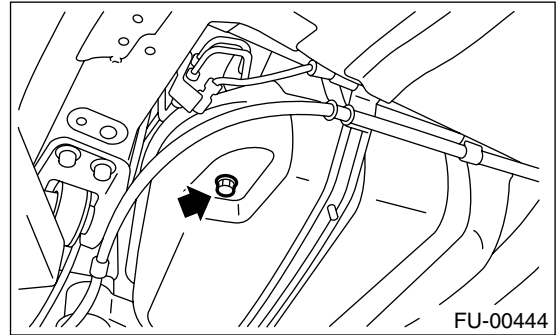

- 6) Tighten fuel drain plug and install front right side tank cover.

###### Tightening torque:

**26 N·m (2.65 kgf-m, 19.2 ft-lb)**

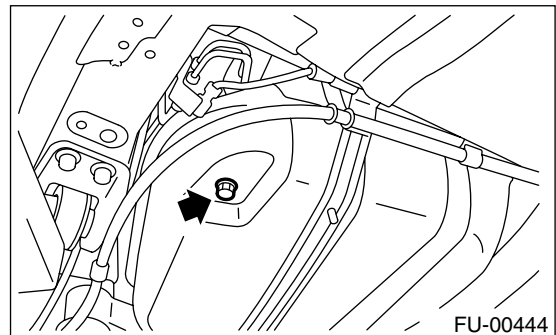

###### Tightening torque:

**18 N·m (1.8 kgf-m, 13.0 ft-lb)**

- 7) Lower the vehicle.

# FUEL

## FUEL INJECTION (FUEL SYSTEMS)

8) Remove sub service hole cover.

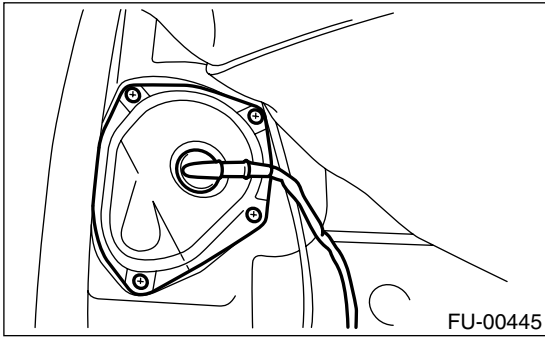

9) Disconnect connector from fuel sub level sensor.

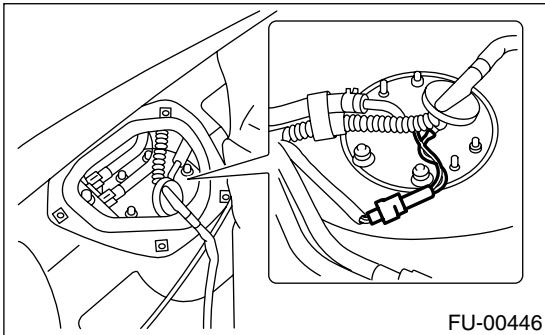

10) Disconnect fuel jet pump hose.

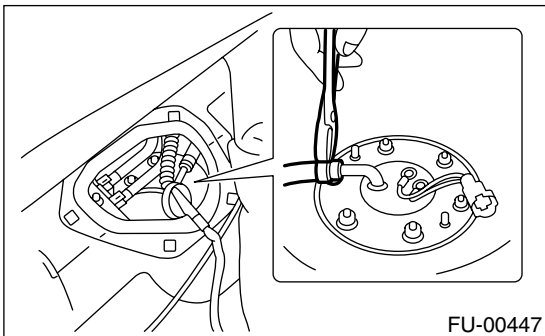

11) Remove fuel sub level sensor.

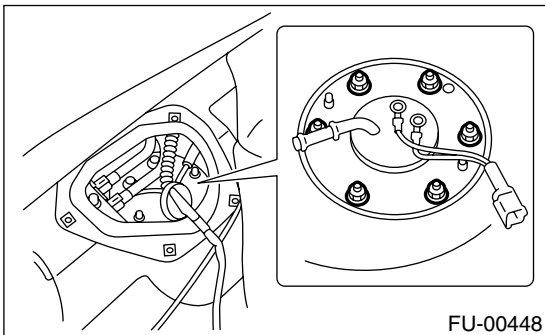

12) Drain fuel from fuel tank by using hand pump.

### WARNING:

Do not use a motor pump when draining fuel.

13) After draining fuel, reinstall fuel sub level sensor.

### Tightening torque:

4.4 N·m (0.45 kgf-m, 3.3 ft-lb)

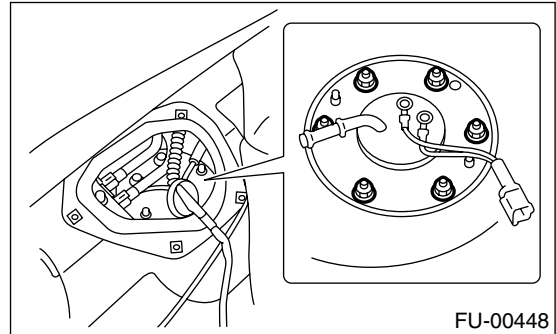

### NOTE:

If you have not removed fuel tank yet, proceed with the procedure below for installation.

(1) Connect fuel jet pump hose.

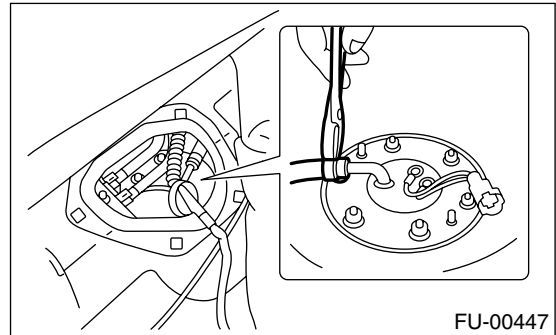

(2) Connect connector from fuel sub level sensor.

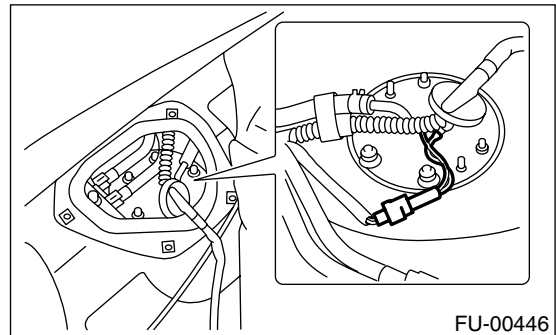

# FUEL

## FUEL INJECTION (FUEL SYSTEMS)

---

(3) Install sub service hole cover.

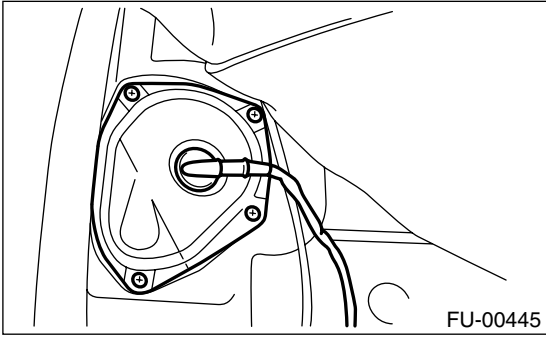

(4) Set rear seat and floor mat.

### 22. Fuel Tank

#### A: REMOVAL

- 1) Set vehicle on the lift.
- 2) Release fuel pressure. <Ref. to FU(H6DO)-50, RELEASING OF FUEL PRESSURE, OPERATION, Fuel.>
- 3) Drain fuel from fuel tank. <Ref. to FU(H6DO)-50, DRAINING FUEL, OPERATION, Fuel.>
- 4) Remove holder clip which secures fuel tank cord on bracket.

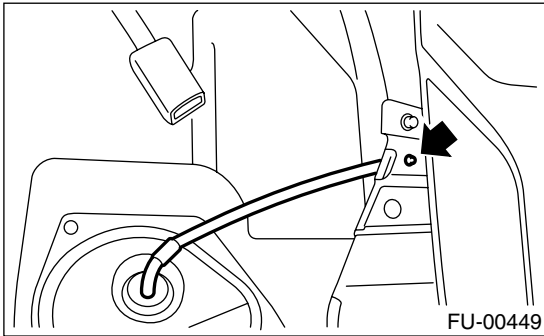

- 5) Disconnect connector of fuel tank cord to rear harness.

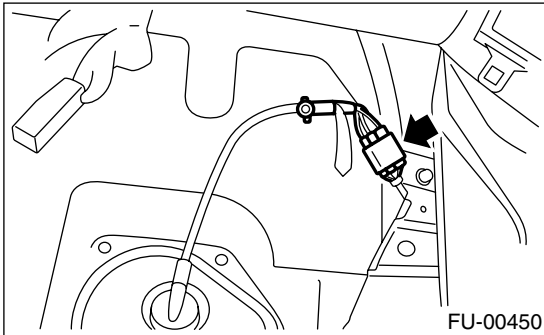

- 6) Push grommet which holds fuel tank cord on service hole cover into body side.

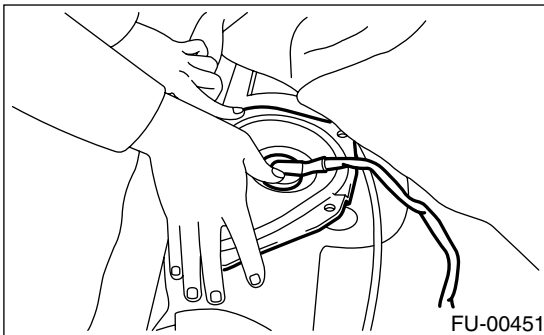

- 7) Using ST, separate quick connector of fuel delivery (A) and return hose (B). <Ref. to FU(H6DO)-75, REMOVAL, Fuel Delivery, Return and Evaporation Lines.>

ST 42099AE000 CONNECTOR REMOVER

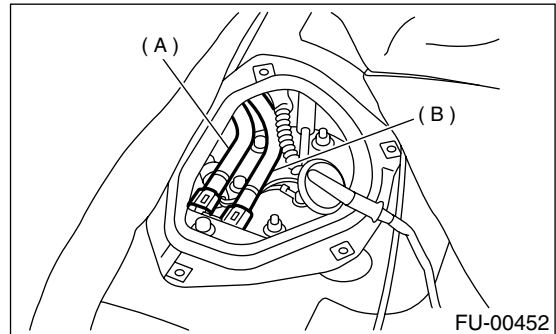

- 8) Remove parking brake cable.
  - (1) Remove console box. <Ref. to EI-45, REMOVAL, Console Box.>
  - (2) Remove parking brake bracket and disconnect parking brake cable from equalizer. <Ref. to PB-6, REMOVAL, Parking Brake Cable.>

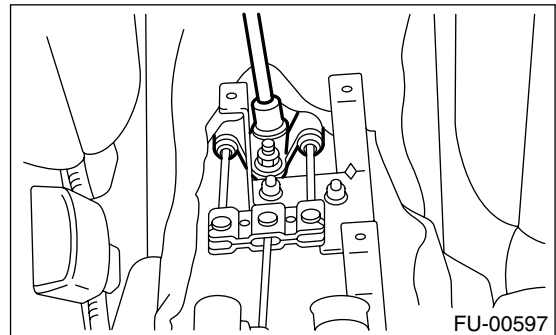

- 9) Remove trunk trim. (Sedan model) <Ref. to EI-59, REMOVAL, Trunk Trim.>
- 10) Remove rear quarter lower trim. <Ref. to EI-52, WAGON, REMOVAL, Rear Quarter Trim.>
- 11) Remove pipe protector.

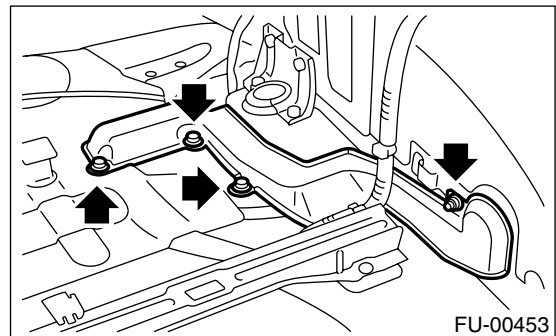

# FUEL TANK

## FUEL INJECTION (FUEL SYSTEMS)

12) Using ST, separate quick connector of evaporation pipe (A). <Ref. to FU(H6DO)-75, REMOVAL, Fuel Delivery, Return and Evaporation Lines.>  
ST 42099AE000 CONNECTOR REMOVER

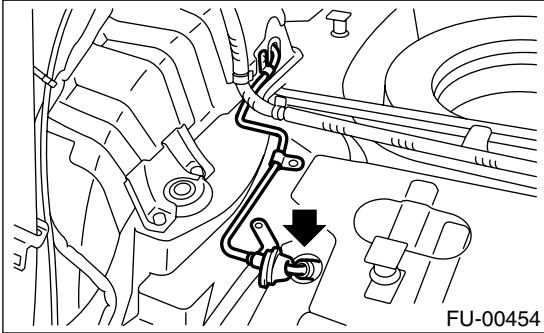

- 13) Remove wheel nuts from rear wheels.
- 14) Lift-up the vehicle.
- 15) Remove rear wheel.
- 16) Remove front side fuel tank cover.

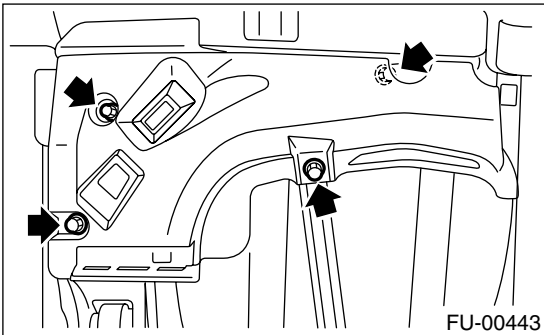

17) Remove rear exhaust pipe and muffler.

### NOTE:

To facilitate removal, apply a coat of SUBARU CRC to matching area of rubber cushions in advance.

### **SUBARU CRC (Part No. 004301003)**

- (1) Separate rear exhaust pipe from center exhaust pipe.

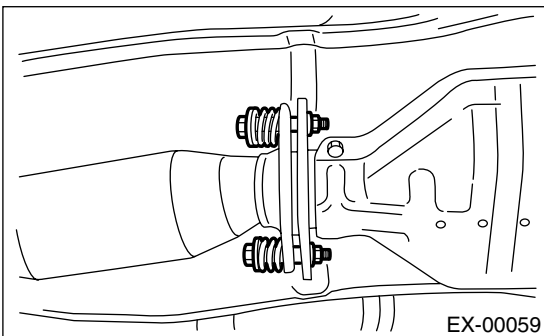

- (2) Remove left and right rubber cushions.

### CAUTION:

Be careful not to pull down muffler.

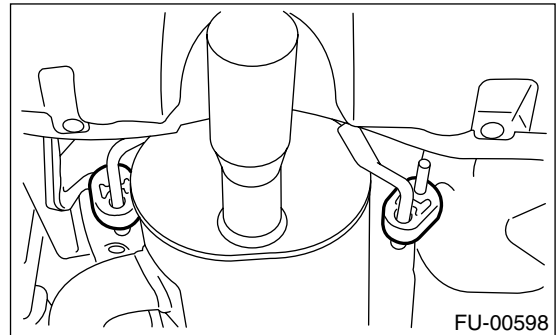

- (3) Remove front rubber cushion and detach muffler assembly.

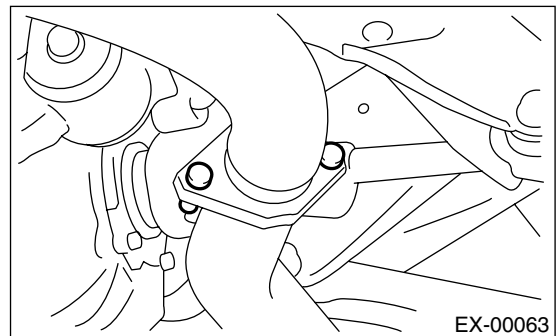

18) Remove propeller shaft. <Ref. to DS-15, REMOVAL, Propeller Shaft.>

- 19) Disconnect connector from ABS sensor.

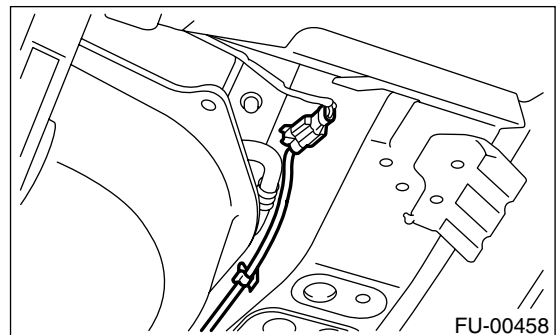

20) Remove bolts which hold parking brake cable holding bracket.

21) Remove parking brake cable from cabin by forcibly pulling it backward.

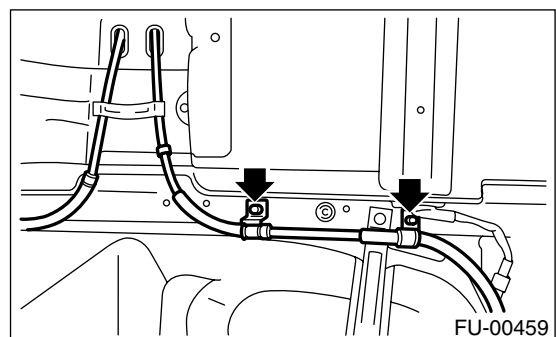

# FUEL TANK

## FUEL INJECTION (FUEL SYSTEMS)

22) Remove bolts which hold parking brake cable holding bracket.

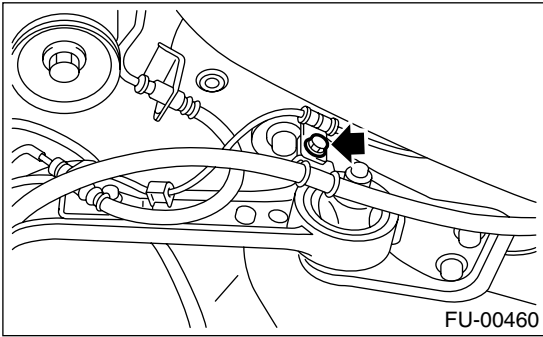

(2) Remove bolt which holds rear shock absorber to rear suspension arm.

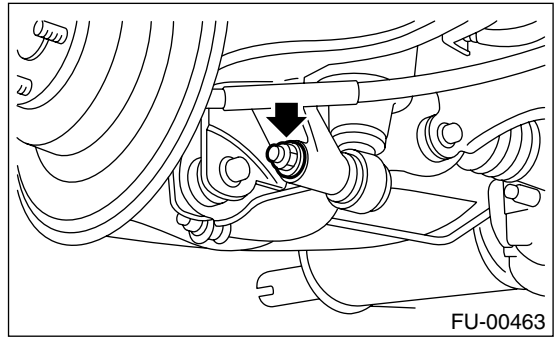

23) Remove bolts which hold rear brake hoses holding bracket.

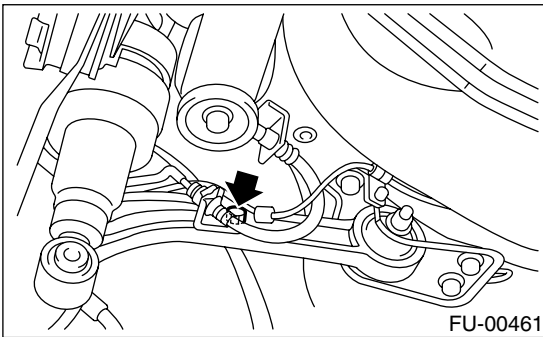

(3) Remove bolts which secure rear suspension assembly to body.

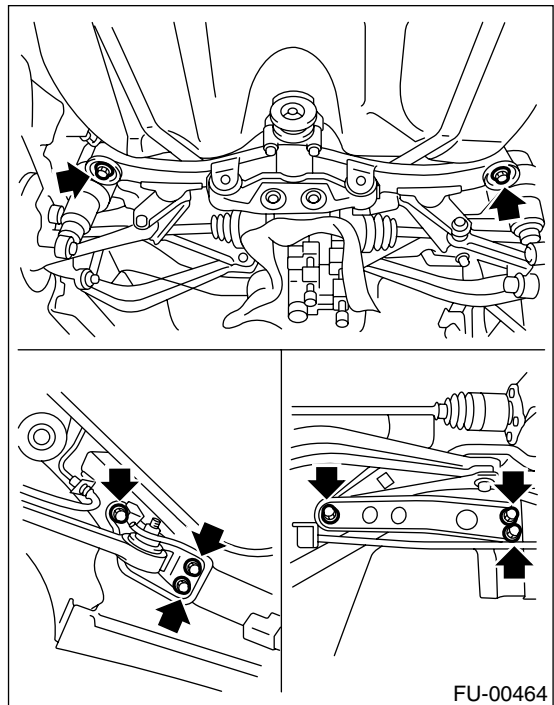

24) Remove rear brake caliper, then tie it up to the body side of the vehicle as shown in figure.

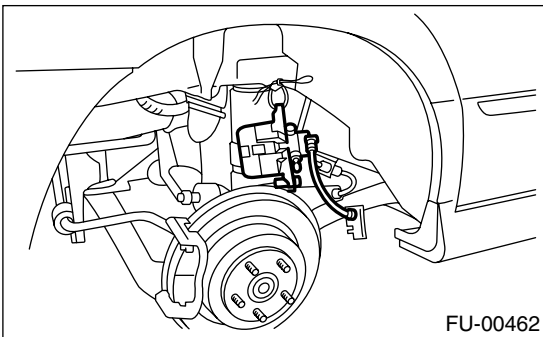

(4) Remove rear suspension assembly.

26) Remove rear side fuel tank cover.

25) Remove rear suspension assembly.

### WARNING:

**A helper is required to perform this work.**

(1) Support rear differential with transmission jack.

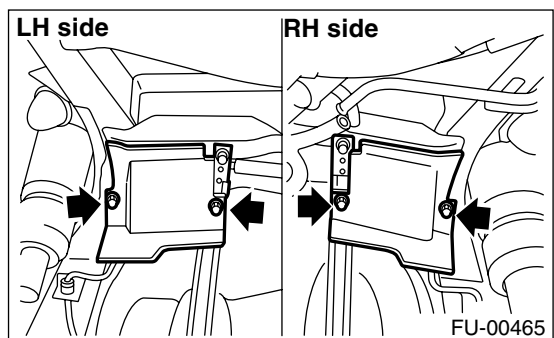

# FUEL TANK

## FUEL INJECTION (FUEL SYSTEMS)

27) Disconnect fuel filler hose (A) and fuel tank pressure sensor (B) hose.

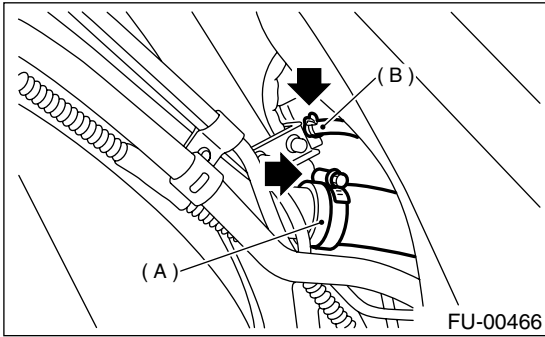

28) Disconnect air vent hose (A) from evaporation pipe assembly and disconnect evaporation hose (I) from pressure control solenoid valve.

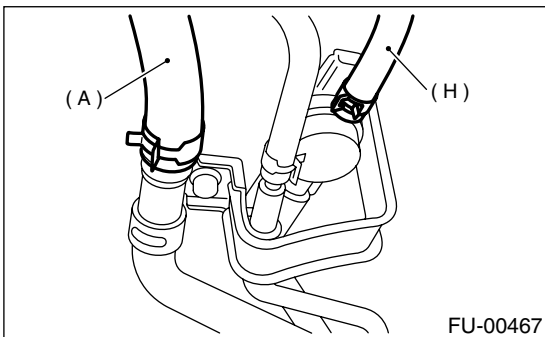

29) Support fuel tank with transmission jack, remove bolts from bands and dismount fuel tank from the vehicle.

**WARNING:**  
A helper is required to perform this work.

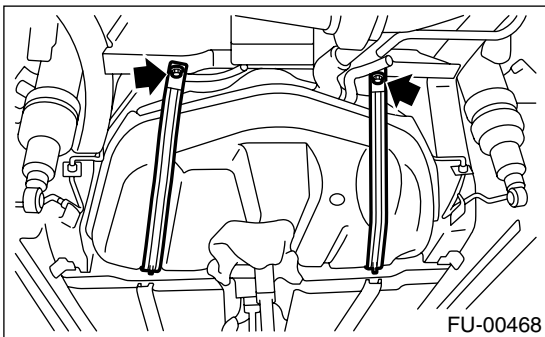

## B: INSTALLATION

- 1) Support fuel tank with transmission jack and push fuel tank harness into access hole with grommet.
- 2) Set fuel tank and temporarily tighten bolts of fuel tank bands.

**WARNING:**  
A helper is required to perform this work.

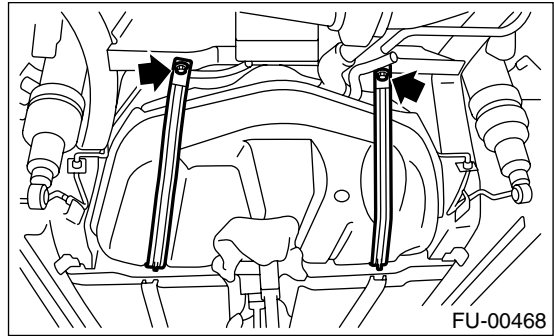

3) Connect air vent hose (A) to evaporation pipe assembly and connect evaporation hose (B) to pressure control solenoid valve.

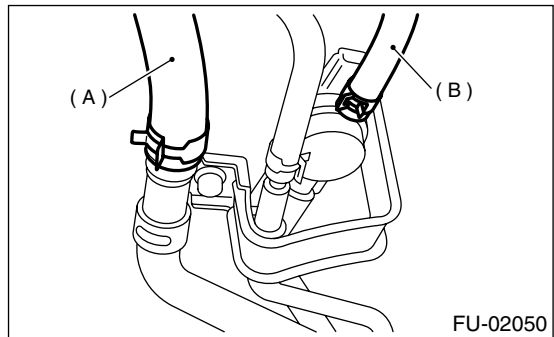

4) Connect fuel filler hose (A) and fuel tank pressure sensor hose (B).

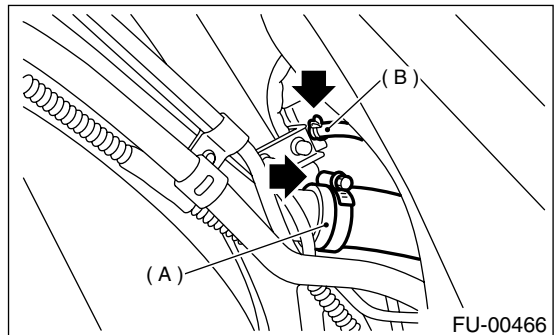

5) Tighten band mounting bolts.

**Tightening torque:**  
**33 N·m (3.4 kgf-m, 25 ft-lb)**

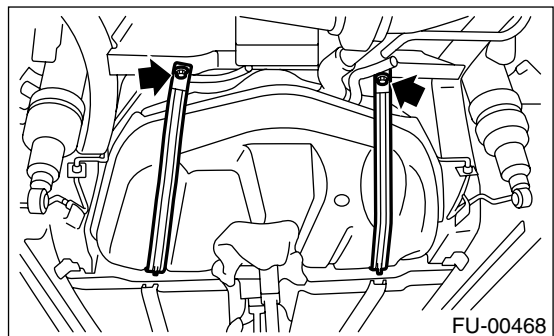



6) Install rear side fuel tank cover.

**Tightening torque:**

**18 N·m (1.8 kgf·m, 13.0 ft·lb)**

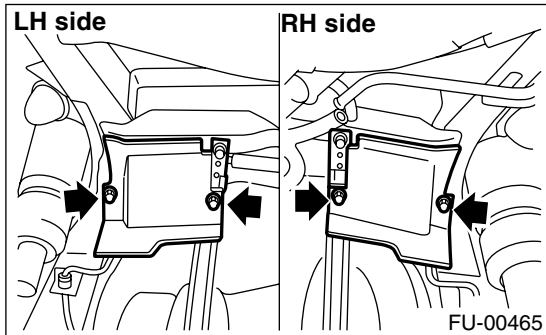

7) Install rear suspension assembly.

**WARNING:**

**A helper is required to perform this work.**

(1) Support rear suspension assembly and then tighten bolts which secure rear suspension assembly.

**Tightening torque:**

**T1: 172 N·m (17.5 kgf·m, 127 ft·lb)**

**T2: 108 N·m (11.0 kgf·m, 80 ft·lb)**

**T3: 66 N·m (6.7 kgf·m, 48 ft·lb)**

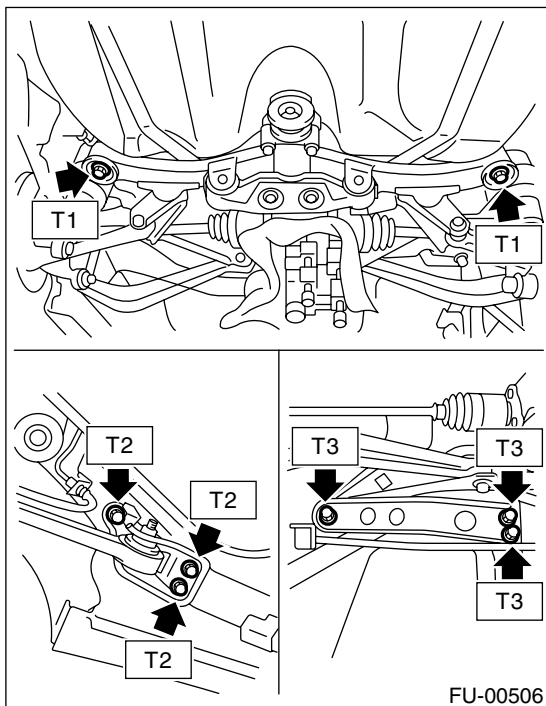

(2) Tighten bolt which holds rear shock absorber to rear suspension arm. <Ref. to RS-14, INSTALLATION, Link Upper.>

**Tightening torque:**

**157 N·m (16 kgf·m, 116 ft·lb)**

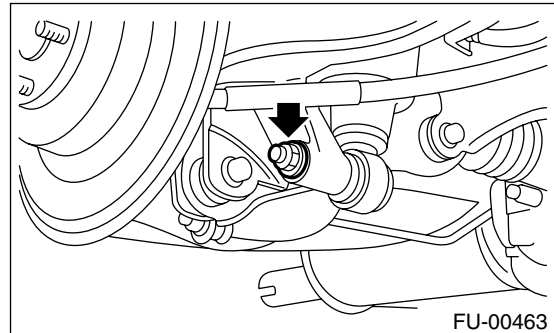

8) Install rear brake caliper. <Ref. to BR-22, INSTALLATION, Rear Disc Brake Assembly.>

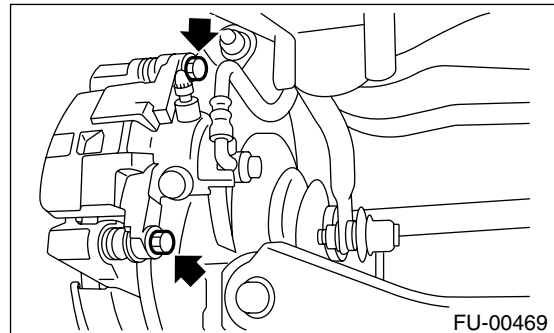

9) Tighten bolts which hold rear brake hoses holding bracket.

**Tightening torque:**

**33 N·m (3.4 kgf·m, 25 ft·lb)**

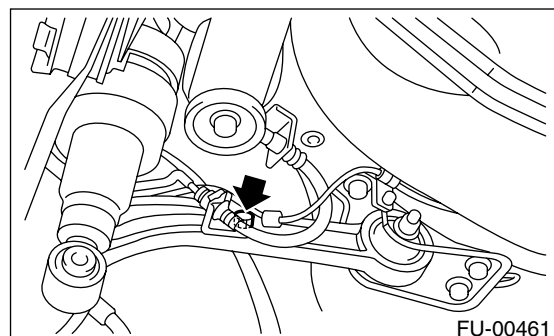

10) Install parking brake cable to cabin by forcibly pushing it forward.

# FUEL TANK

## FUEL INJECTION (FUEL SYSTEMS)

11) Tighten bolts which hold parking brake cable holding bracket.

**Tightening torque:**

**18 N·m (1.8 kgf-m, 13.0 ft-lb)**

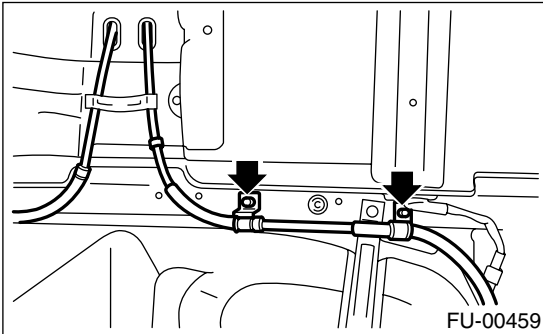

**Tightening torque:**

**32 N·m (3.3 kgf-m, 23.9 ft-lb)**

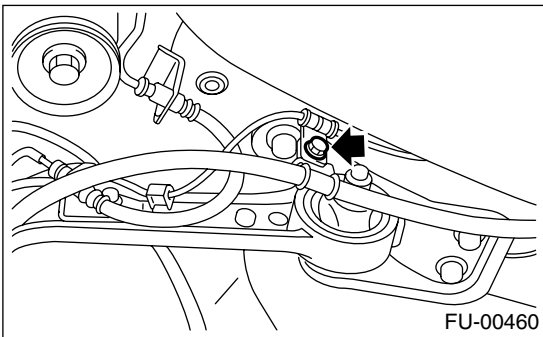

12) Connect connector to ABS sensor.

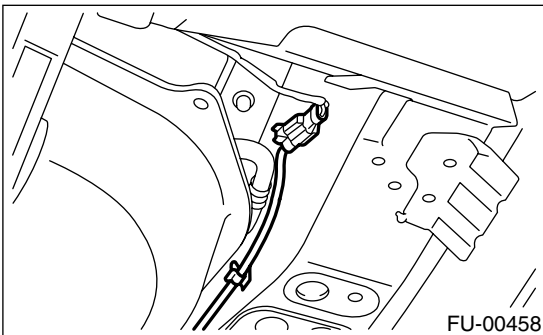

13) Install propeller shaft. <Ref. to DS-16, INSTALLATION, Propeller Shaft.>

14) Install rear exhaust pipe and muffler.

**NOTE:**

To facilitate the procedure, apply a coat of SUBARU CRC to matching area of rubber cushions in advance.

**SUBARU CRC (Part No. 004301003)**

(1) Install left and right rubber cushions.

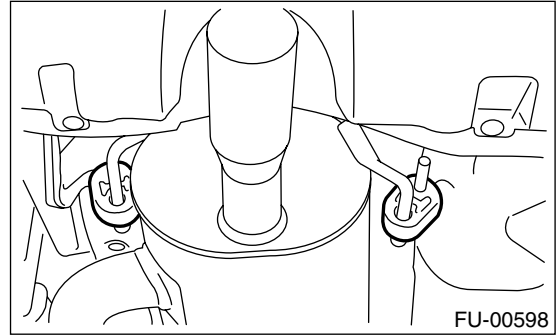

(2) Install front rubber cushion and attach muffler assembly.



(3) Install rear exhaust pipe to front exhaust pipe.

**Tightening torque:**

**18 N·m (1.8 kgf-m, 13.0 ft-lb)**

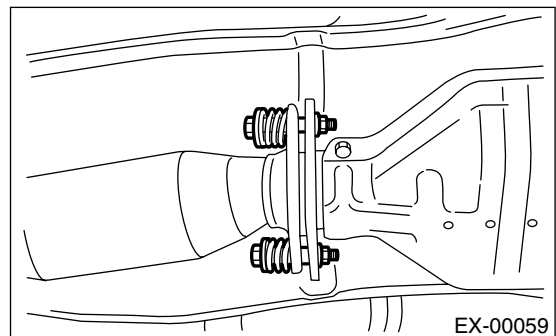

15) Install front side fuel tank cover.

**Tightening torque:**

**18 N·m (1.8 kgf-m, 13.0 ft-lb)**

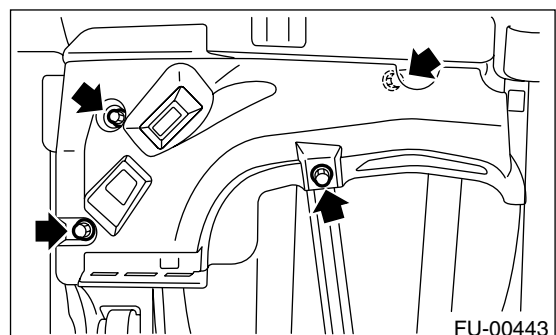

# FUEL TANK

## FUEL INJECTION (FUEL SYSTEMS)

- 16) Install rear wheel.
- 17) Lower the vehicle.
- 18) Tighten wheel nuts.
- 19) Install parking brake cable. <Ref. to PB-6, INSTALLATION, Parking Brake Cable.>

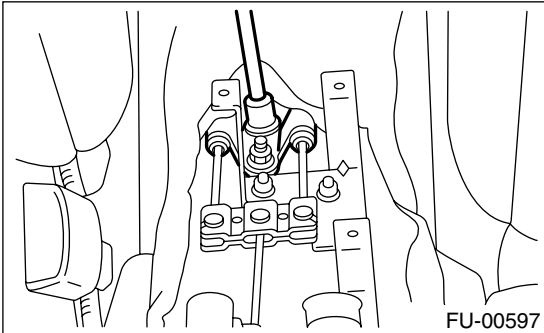

- 20) Install console box. <Ref. to EI-45, INSTALLATION, Console Box.>
- 21) Connect fuel hoses and hold them with quick connector. <Ref. to FU(H6DO)-76, INSTALLATION, Fuel Delivery, Return and Evaporation Lines.>

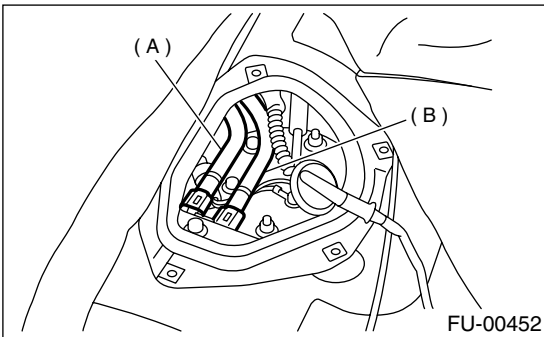

- (A) Delivery hose
- (B) Return hose

- 22) Connect evaporation pipe and hold it with quick connector. <Ref. to FU(H6DO)-76, INSTALLATION, Fuel Delivery, Return and Evaporation Lines.>

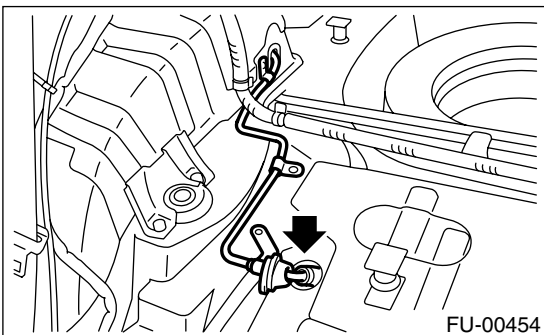

- 23) Install pipe protector.

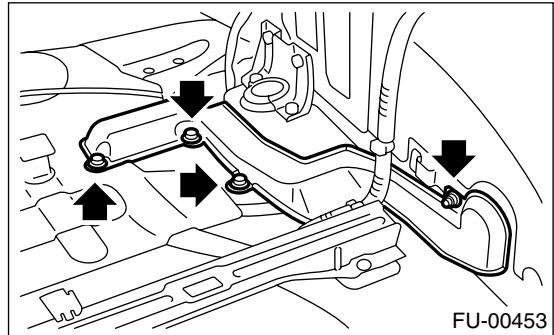

- 24) Install trunk trim. (Sedan model) <Ref. to EI-59, INSTALLATION, Trunk Trim.>
- 25) Install rear quarter lower trim. (Wagon model) <Ref. to EI-52, WAGON, REMOVAL, Rear Quarter Trim.>
- 26) Connect fuel jet pump hose.

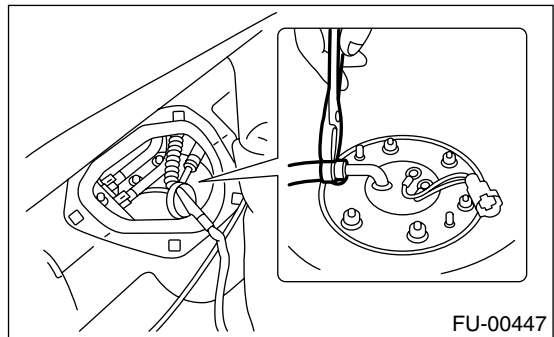

- 27) Connect connector to fuel sub level sensor.

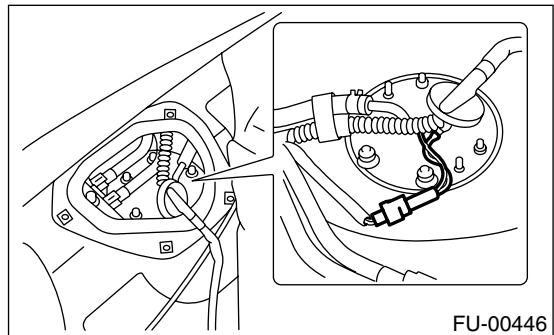

- 28) Install sub service hole cover.

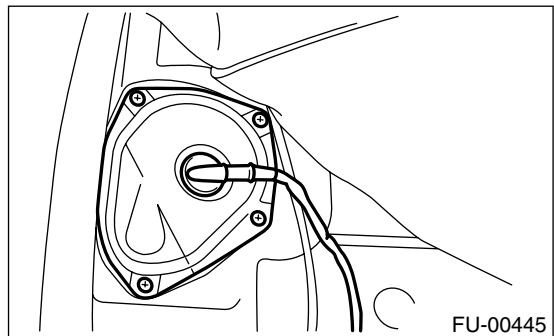

# FUEL TANK

## FUEL INJECTION (FUEL SYSTEMS)

---

- 29) Connect connectors to fuel tank cord and plug service hole with grommet.

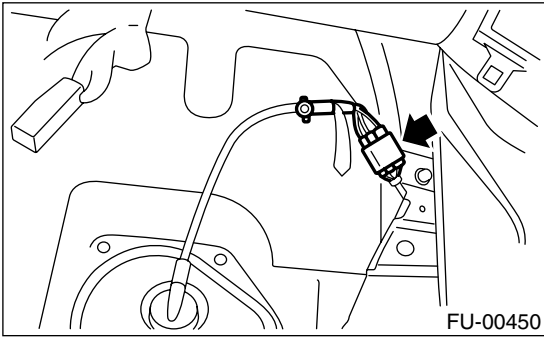

- 30) Install holder clip which secures fuel tank cord on bracket.

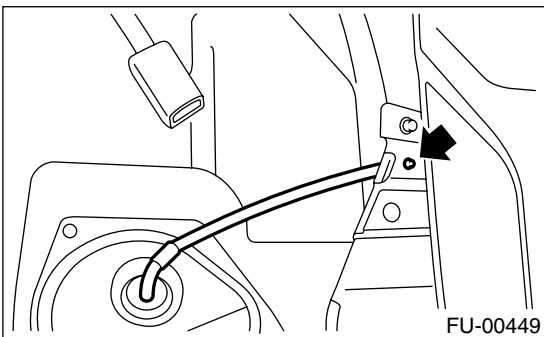

- 31) Set rear seat and floor mat.  
32) Connect connector to fuel pump relay.

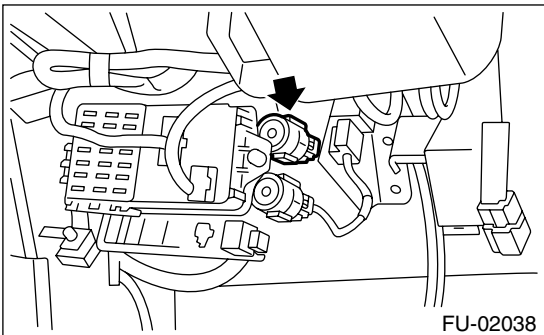

- 33) Adjust parking brake lever stroke. <Ref. to PB-10, ADJUSTMENT, Parking Brake Assembly.>  
34) Check wheel alignment and adjust if necessary. <Ref. to FS-6, INSPECTION, Wheel Alignment.>

### **C: INSPECTION**

- 1) Make sure there are no cracks, holes, or other damage on the fuel tank.
- 2) Make sure that the fuel hoses and fuel pipes are not cracked and that connections are tight.

## 23. Fuel Filler Pipe

### A: REMOVAL

**WARNING:**

- Place “NO FIRE” signs near the working area.
- Be careful not to spill fuel on the floor.

- 1) Drain fuel from fuel tank. <Ref. to FU(H6DO)-50, DRAINING FUEL, OPERATION, Fuel.>
- 2) Remove rear exhaust pipe and muffler.

**NOTE:**

To facilitate removal, apply a coat of SUBARU CRC to matching area of rubber cushions in advance.

**SUBARU CRC (Part No. 004301003)**

- (1) Separate rear exhaust pipe from front exhaust pipe.

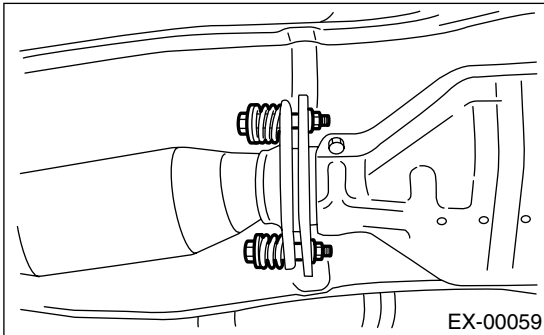

- (2) Remove left and right rubber cushions.

**CAUTION:**

Be careful not to pull down muffler.

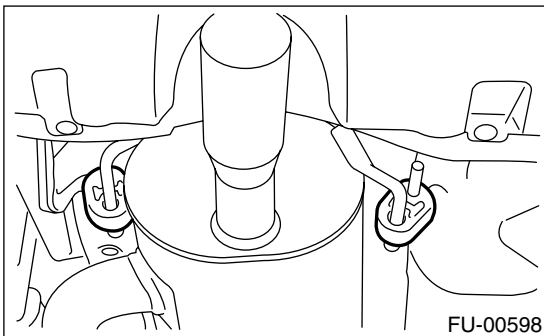

- (3) Remove front rubber cushion and detach muffler assembly.

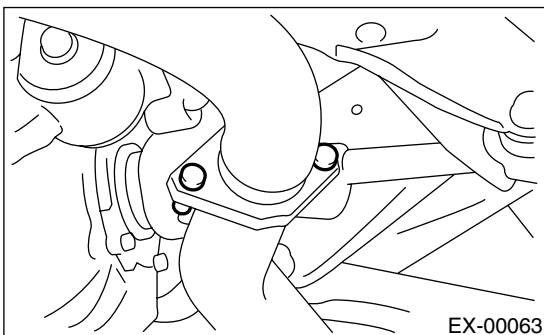

- 3) Remove heat sealed cover.

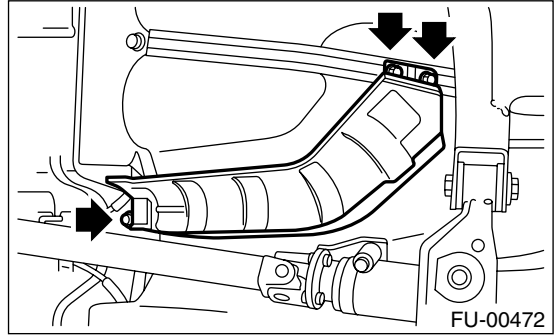

- 4) Place transmission jack under sub frame.

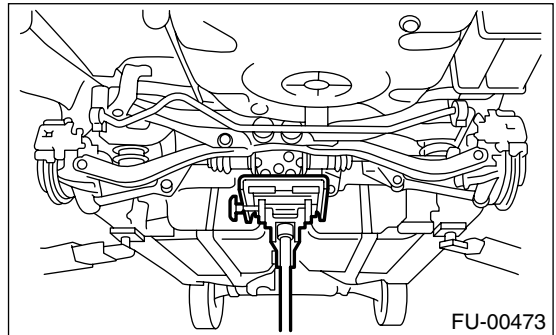

- 5) Remove bolt which holds rear shock absorber to rear suspension arm.

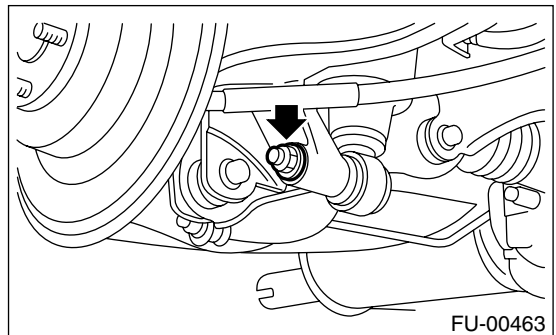

# FUEL FILLER PIPE

## FUEL INJECTION (FUEL SYSTEMS)

6) Remove bolts which hold rear sub frame on body.

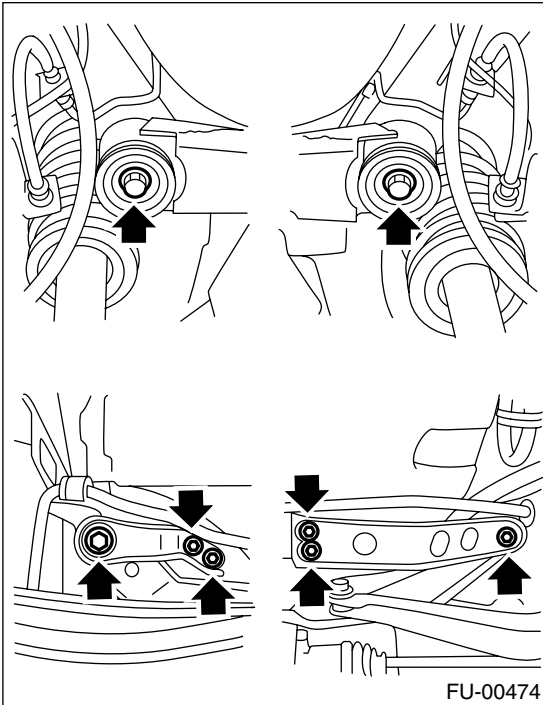

7) Lower the rear sub frame.

**CAUTION:**  
Be sure to lower sub frame slowly.

**A = 150 mm (5.91 in)**

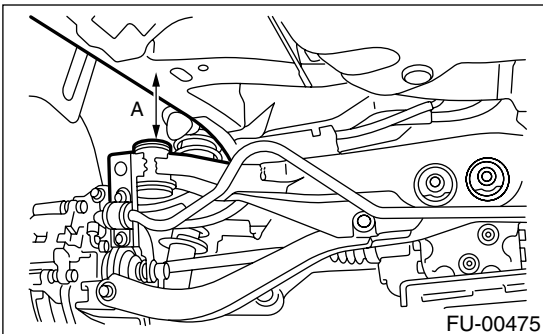

8) Remove fuel filler pipe protector.

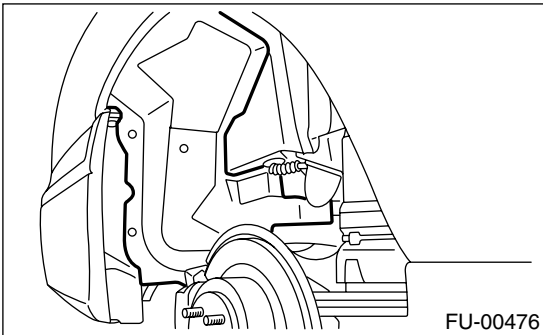

9) Disconnect air vent hose (A) and evaporation hose (B) from evaporation pipe assembly.

10) Disconnect evaporation hose (C) from pressure control solenoid valve.

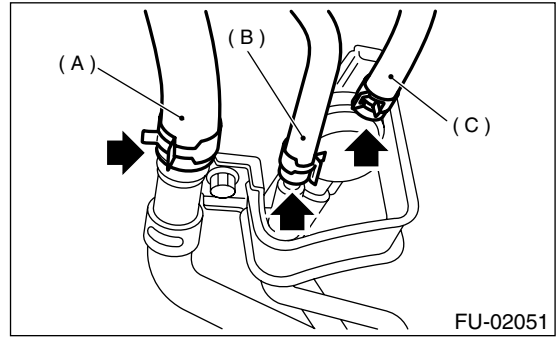

11) Remove bolt which holds evaporation pipe assembly on body.

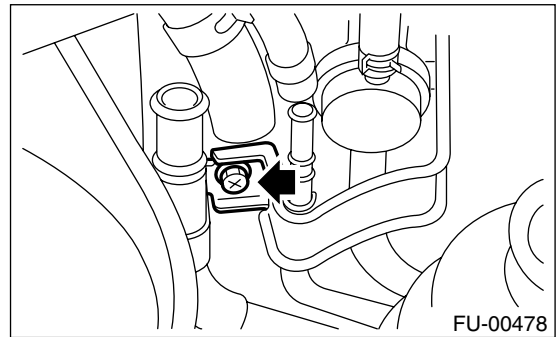

12) Disconnect fuel filler hose.

13) Remove bolt which holds fuel pressure sensor on fuel filler pipe and remove bolt which holds fuel filler pipe on body.

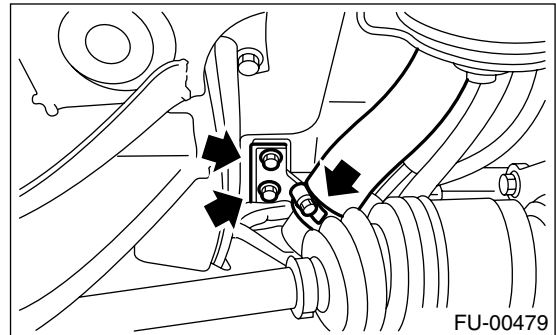

14) Disconnect canister hose from evaporation pipe assembly.

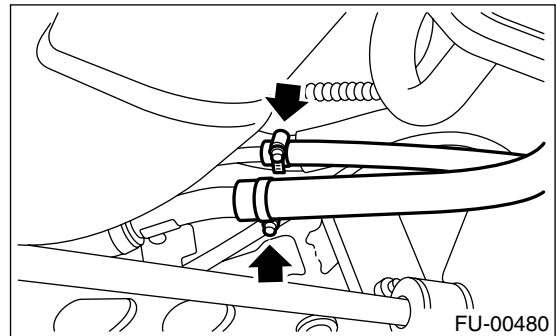

# FUEL FILLER PIPE

FUEL INJECTION (FUEL SYSTEMS)

15) Disconnect evaporation hose (O) from fuel filler pipe.

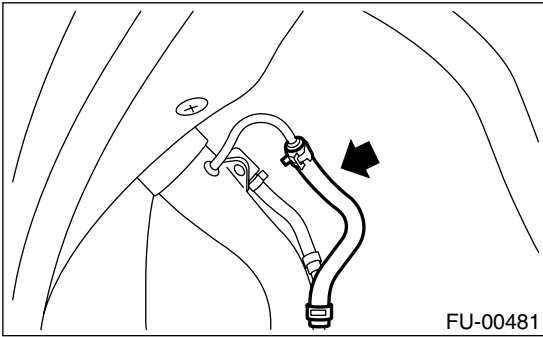

16) Remove bolt which holds fuel filler pipe to body.

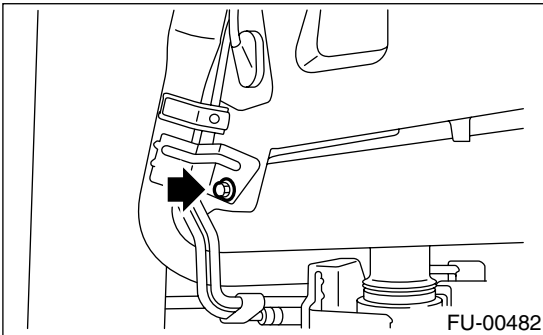

17) Remove fuel filler pipe to under side of the vehicle.

## B: INSTALLATION

1) Hold fuel filler flap open.  
2) Set fuel saucer (A) with rubber packing (C) and insert fuel filler pipe into hole from the inner side of apron.

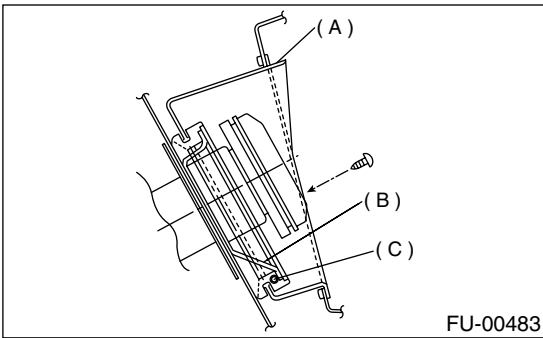

3) Align holes in fuel filler pipe neck and set cup (B), and tighten screws.

### NOTE:

If edges of rubber packing are folded toward the inside, straighten it with a screwdriver.

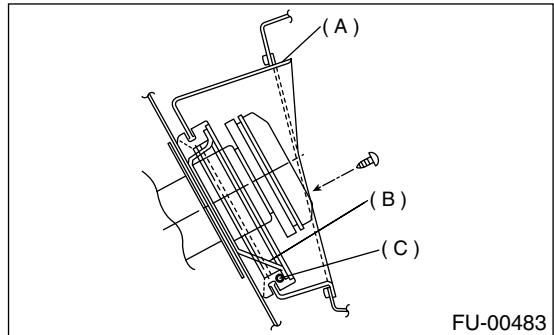

4) Tighten bolt which holds fuel filler pipe on body.

### Tightening torque:

**7.5 N·m (0.75 kgf·m, 5.4 ft·lb)**

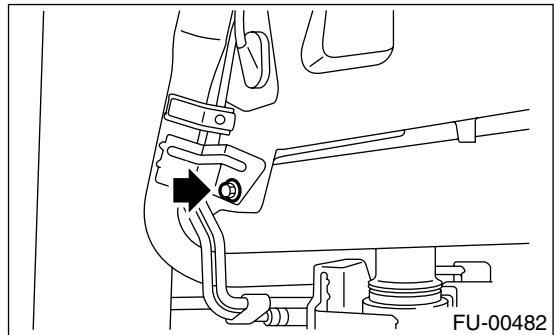

5) Insert evaporation hose approximately 25 to 30 mm (0.98 to 1.18 in) into the lower end of evaporation pipe and hold clip.

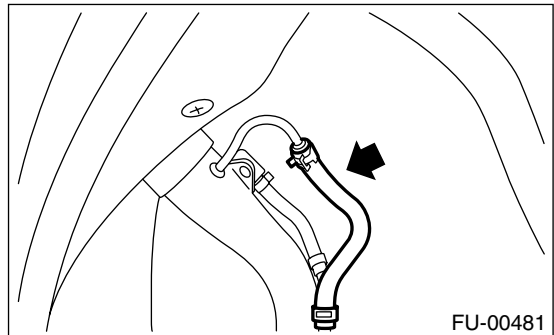

# FUEL FILLER PIPE

## FUEL INJECTION (FUEL SYSTEMS)

$L = 27.5 \pm 2.5 \text{ mm (1.083 \pm 0.098 in)}$

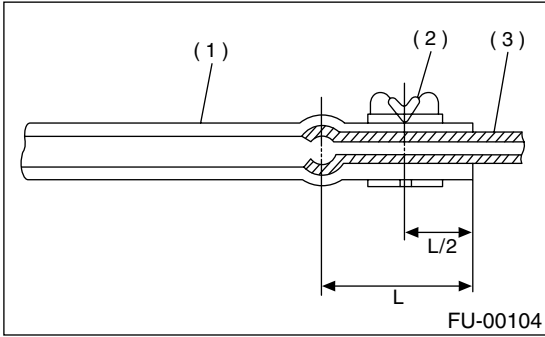

- (1) Hose
- (2) Clip
- (3) Pipe

6) Insert canister hoses approximately 25 to 30 mm (0.98 to 1.18 in) into the lower end of evaporation pipe assembly and tighten clamp.

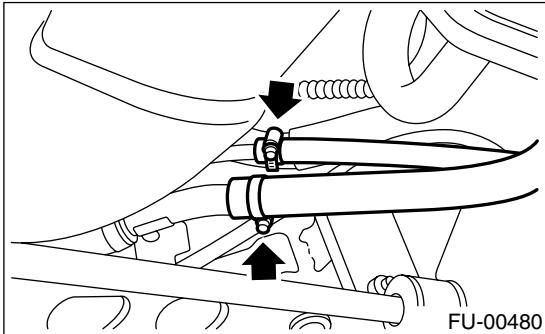

$L = 27.5 \pm 2.5 \text{ mm (1.083 \pm 0.098 in)}$

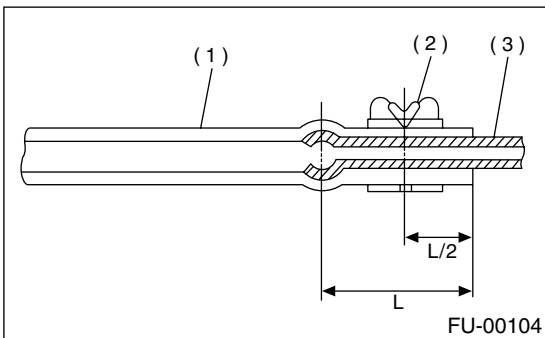

- (1) Hose
- (2) Clip
- (3) Pipe

7) Tighten bolt which holds evaporation pipe assembly on body.

**Tightening torque:**  
 $7.5 \text{ N}\cdot\text{m (0.75 kgf}\cdot\text{m, 5.4 ft}\cdot\text{lb)}$

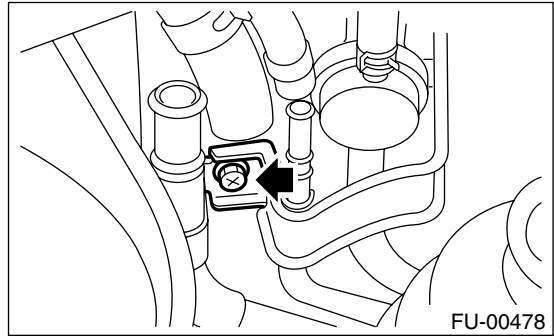

8) Insert air vent hose (A), evaporation hose (B) approximately 25 to 30 mm (0.98 to 1.18 in) into the lower end of evaporation pipe assembly and hold clip.

9) Insert evaporation hose (C) to pressure control solenoid valve and hold clip.

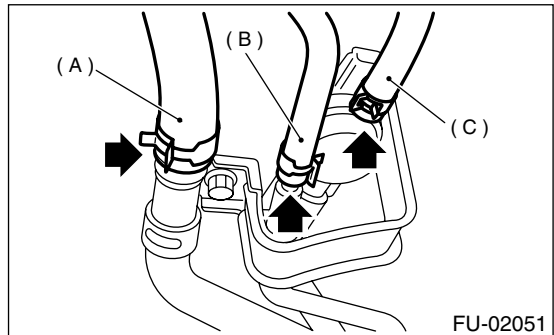

$L = 27.5 \pm 2.5 \text{ mm (1.083 \pm 0.098 in)}$

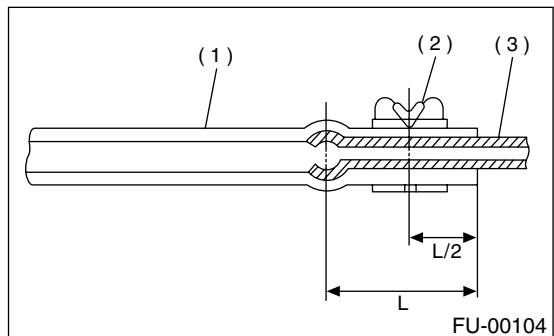

- (1) Hose
- (2) Clip
- (3) Pipe

10) Tighten bolt which holds fuel filler pipe on body and tighten bolt which holds fuel pressure sensor on fuel filler pipe.

**Tightening torque:**  
 $7.5 \text{ N}\cdot\text{m (0.75 kgf}\cdot\text{m, 5.4 ft}\cdot\text{lb)}$



# FUEL FILLER PIPE

FUEL INJECTION (FUEL SYSTEMS)

11) Insert fuel filler hose approximately 35 to 40 mm (1.38 to 1.57 in) over the lower end of fuel filler pipe and tighten clamp.

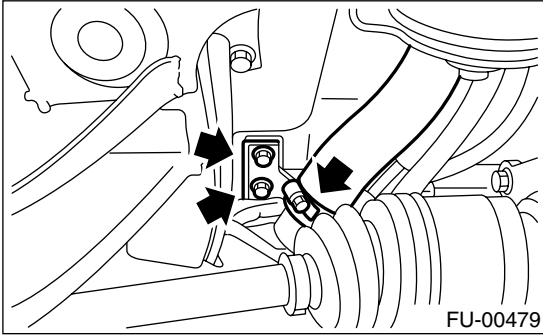

12) Jack-up the rear sub frame and tighten bolts which hold rear sub frame on body.

**Tightening torque:**

**T1: 66 N·m (6.7 kgf·m, 48.5 ft·lb)**

**T2: 172 N·m (17.5 kgf·m, 127 ft·lb)**

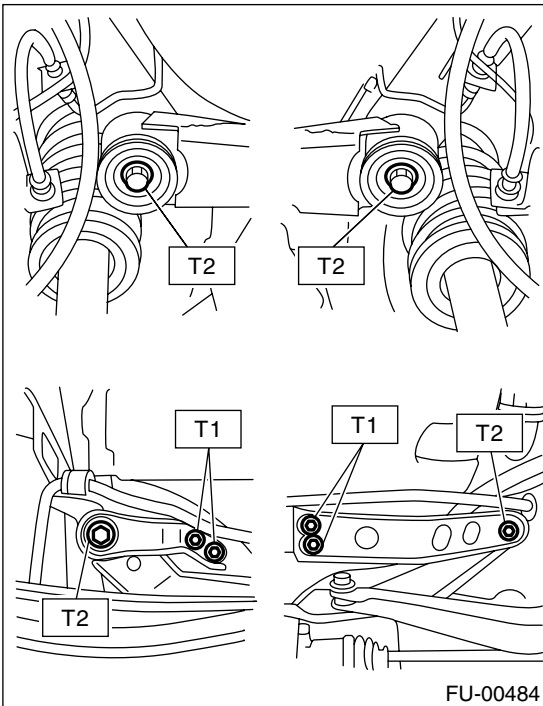

13) Tighten bolt which holds rear shock absorber to rear suspension arm. <Ref. to RS-17, INSTALLATION, Rear Shock Absorber.>

**Tightening torque:**

**157 N·m (16 kgf·m, 116 ft·lb)**

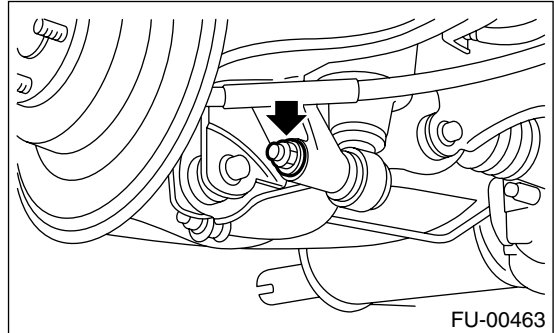

14) Install heat shield cover.

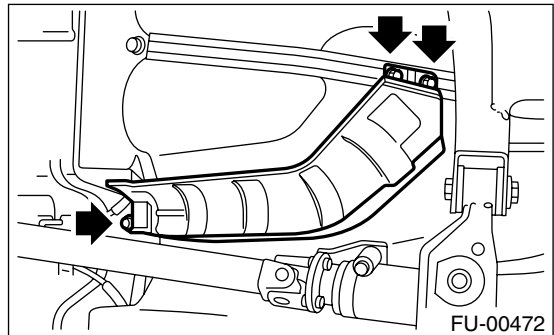

15) Install rear exhaust pipe and muffler.

**NOTE:**

To facilitate the procedure, apply a coat of SUBARU CRC to matching area of rubber cushions in advance.

**SUBARU CRC (Part No. 004301003)**

(1) Install left and right rubber cushions.

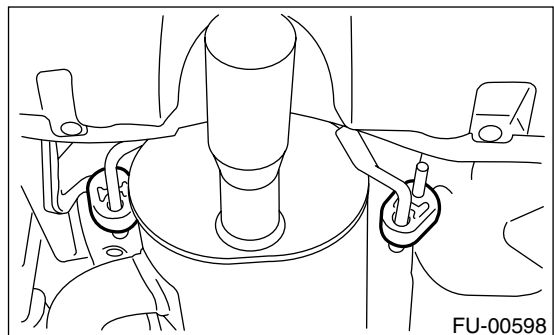

# FUEL FILLER PIPE

## FUEL INJECTION (FUEL SYSTEMS)

(2) Install front rubber cushion and attach muffler assembly.

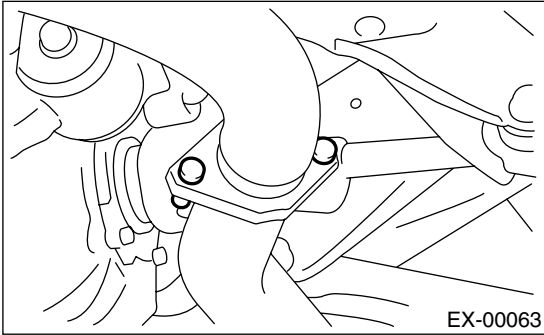

(3) Install rear exhaust pipe to front exhaust pipe.

**Tightening torque:**

**18 N·m (1.8 kgf-m, 13.0 ft-lb)**

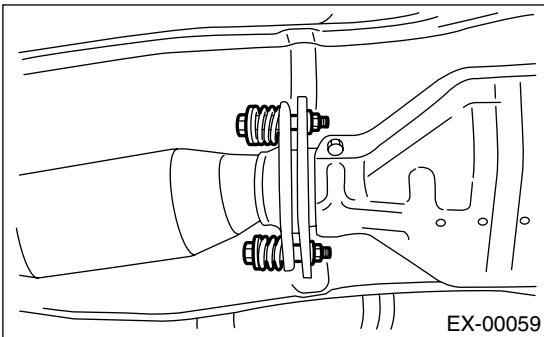

16) Install fuel filler pipe protector.

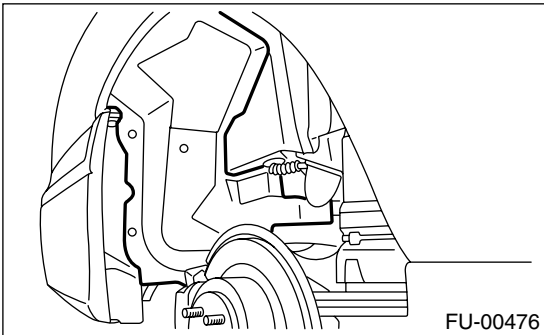

17) Install rear right wheel.

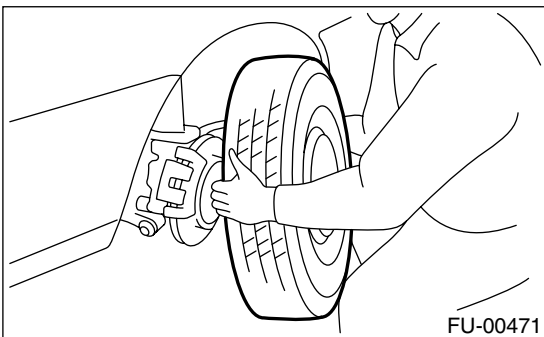

18) Lower the vehicle.

19) Tighten wheel nuts.

20) Connect battery ground cable.

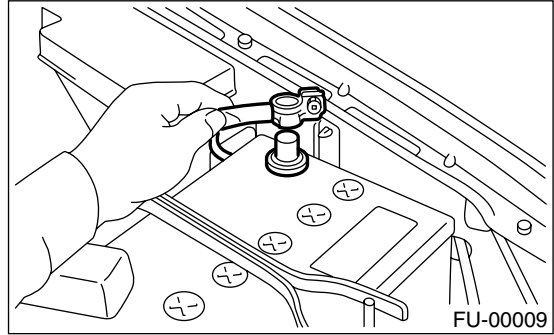

## C: DISASSEMBLY

1) Disconnect evaporation hose from evaporation pipe assembly.

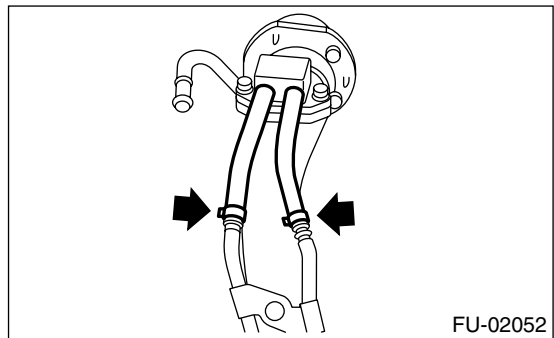

2) Remove shut valve from fuel filler pipe.

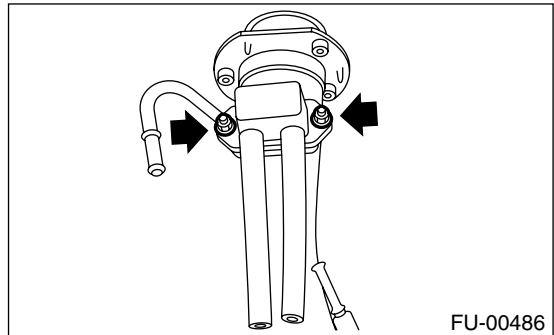

3) Remove nut which holds evaporation pipe assembly on fuel filler pipe.

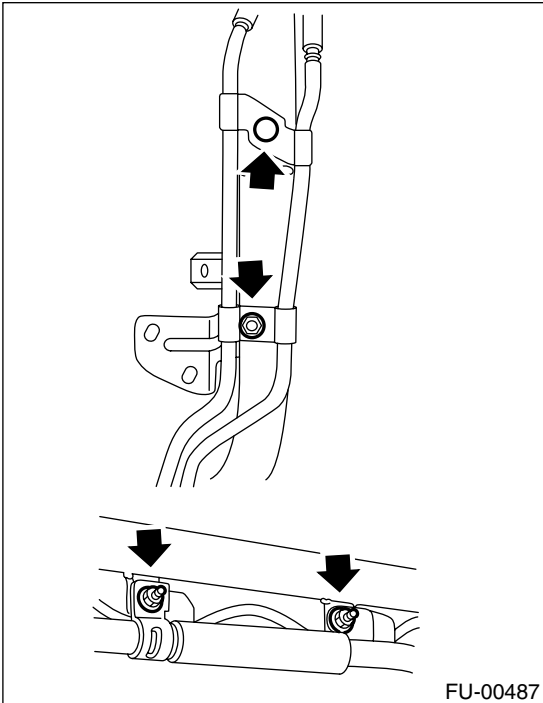

### **D: ASSEMBLY**

Assemble in the reverse order of disassembly.

# FUEL PUMP

## FUEL INJECTION (FUEL SYSTEMS)

### 24. Fuel Pump

#### A: REMOVAL

##### WARNING:

- Place “NO FIRE” signs near the working area.
- Be careful not to spill fuel on the floor.
- During work procedures, if fuel tank is more than 3/4 full, be careful because fuel may spill.

##### NOTE:

Fuel pump assembly consists of fuel pump and fuel level sensor.

- 1) Release fuel pressure. <Ref. to FU(H6DO)-50, RELEASING OF FUEL PRESSURE, OPERATION, Fuel.>
- 2) Drain fuel from fuel tank. <Ref. to FU(H6DO)-50, DRAINING FUEL, OPERATION, Fuel.>
- 3) Raise rear seat and turn floor mat up.
- 4) Remove access hole lid.

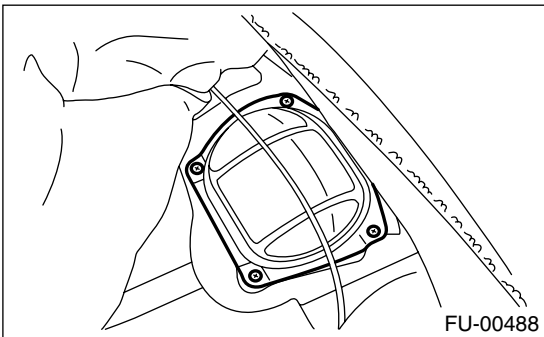

- 5) Disconnect connector from fuel pump.

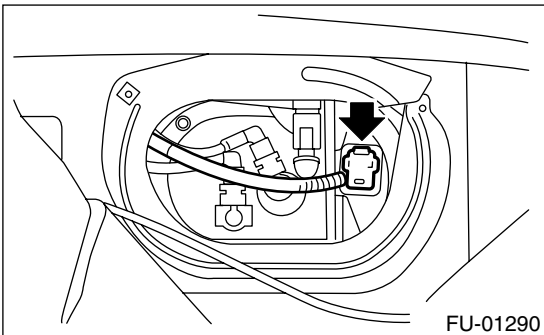

- 6) Using ST, disconnect quick connector and then disconnect fuel delivery hose (A), return hose (B) and jet pump hose. <Ref. to FU(H6DO)-75, REMOVAL, Fuel Delivery, Return and Evaporation Lines.>

ST 42099AE000 CONNECTOR REMOVER

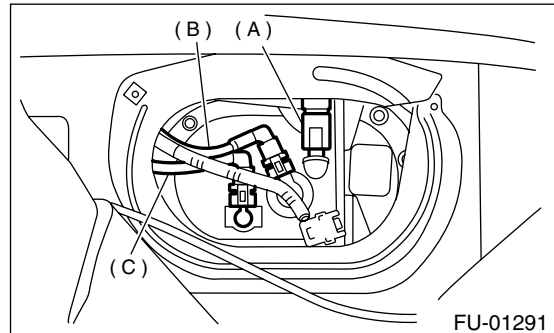

- 7) Remove nuts which install fuel pump assembly onto fuel tank.

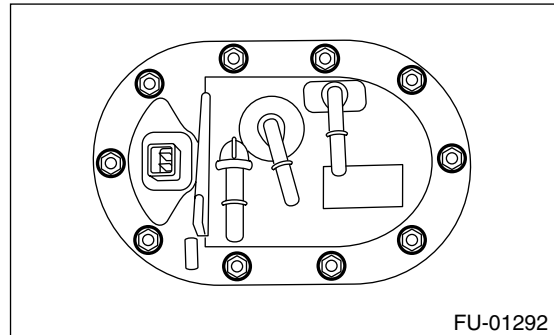

- 8) Take off fuel pump assembly from fuel tank.

#### B: INSTALLATION

Install in the reverse order of removal. Do the following:

- (1) Always use new gaskets.
- (2) Ensure sealing portion is free from fuel or foreign particles before installation.
- (3) Tighten nuts in alphabetical sequence shown in figure to specified torque.

##### Tightening torque:

**5.9 N·m (0.6 kgf-m, 4.3 ft-lb)**

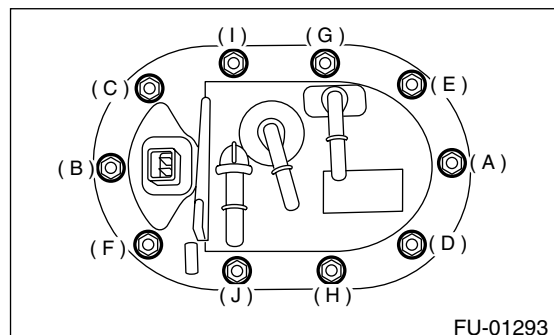

### C: DISASSEMBLY

1) Remove fuel pump and pump holder.

#### NOTE:

When disassembling pump holder, be careful as it is installed with two pawls.

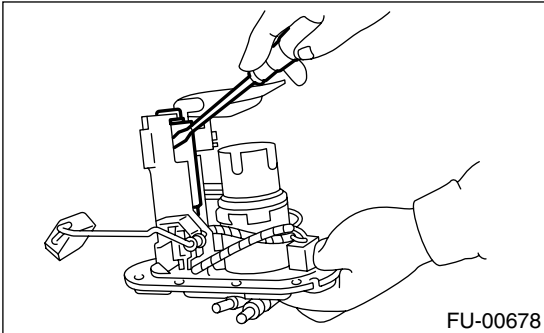

2) Disconnect connector from fuel pump.

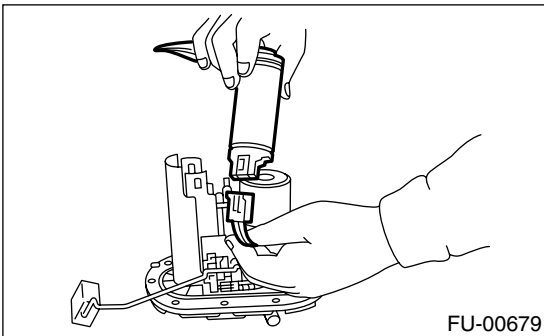

### D: ASSEMBLY

Assemble in the reverse order of disassembly.

### E: INSPECTION

Connect lead harness to connector terminal of fuel pump and apply battery power supply to check whether the pump operates.

#### WARNING:

- Wipe off the fuel completely.
- Keep battery as far apart from fuel pump as possible.
- Be sure to turn the battery supply ON and OFF on the battery side.
- Do not run fuel pump for a long time under no-load condition.

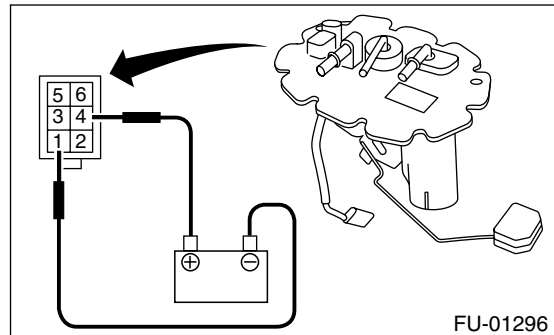

# FUEL LEVEL SENSOR

FUEL INJECTION (FUEL SYSTEMS)

## 25. Fuel Level Sensor

### A: REMOVAL

#### WARNING:

- Place “NO FIRE” signs near the working area.
- Be careful not to spill fuel on the floor.

#### NOTE:

Fuel level sensor is built in fuel pump assembly.

- 1) Remove fuel pump assembly. <Ref. to FU(H6DO)-68, REMOVAL, Fuel Pump.>
- 2) Disconnect connector from fuel pump bracket.

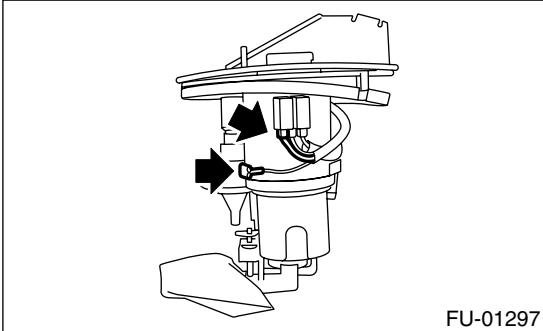

- 3) Pushing the pawls with a screwdriver, remove fuel meter unit by pulling it downwards.

#### NOTE:

If the retainer pawls are broken during removal, the fuel level sensor must be replaced with a new one.

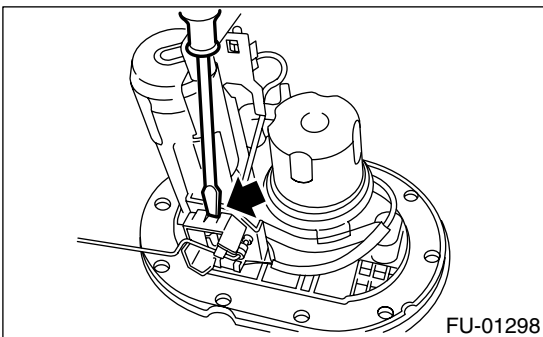

### B: INSTALLATION

Install in the reverse order of removal.

#### WARNING:

- Ground cable must be connected.
- Spark may occur and ignite if fuel is nearby.

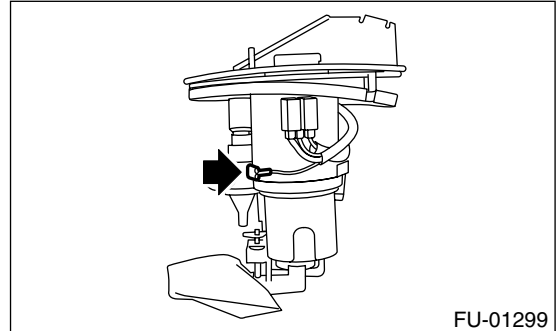

# FUEL SUB LEVEL SENSOR

FUEL INJECTION (FUEL SYSTEMS)

## 26. Fuel Sub Level Sensor

### A: REMOVAL

#### WARNING:

- Place "NO FIRE" signs near the working area.
- Be careful not to spill fuel on the floor.
- During work procedures, if fuel tank is more than 3/4 full, be careful because fuel may spill.

- 1) Drain fuel from fuel tank. <Ref. to FU(H6DO)-50, DRAINING FUEL, OPERATION, Fuel.>
- 2) Raise rear seat and turn floor mat up. (Wagon model)
- 3) Remove rear seat. (Sedan model)
- 4) Remove service hole cover.

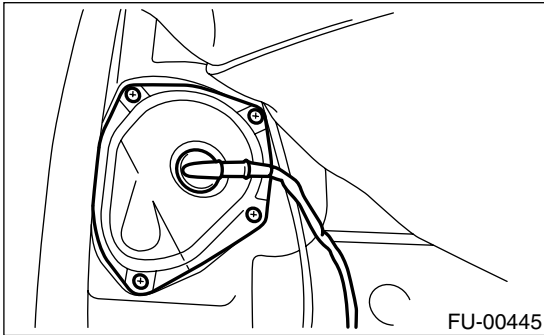

- 5) Disconnect connector from fuel sub level sensor.

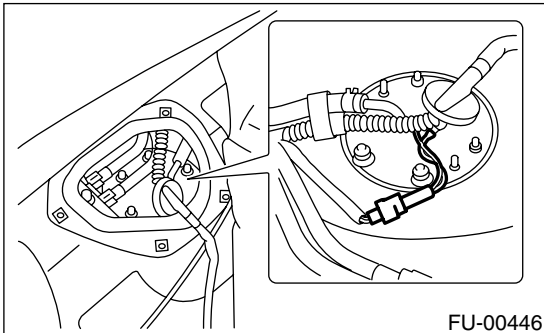

- 6) Disconnect fuel jet pump hose.

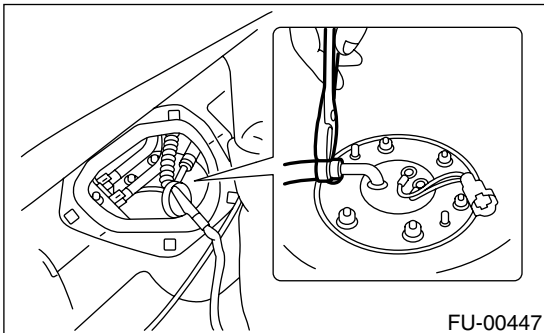

- 7) Remove bolts which install fuel sub level sensor on fuel tank.

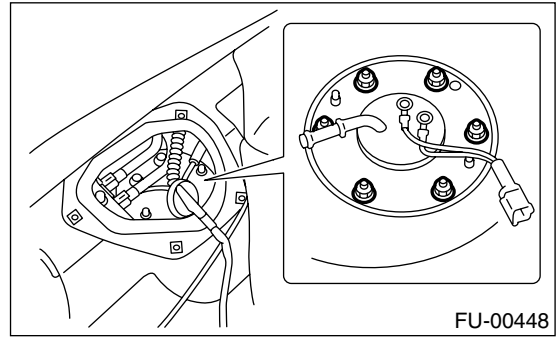

- 8) Remove fuel sub level sensor.

### B: INSTALLATION

Install in the reverse order of removal.

#### Tightening torque:

**4.4 N·m (0.45 kgf·m, 3.3 ft·lb)**

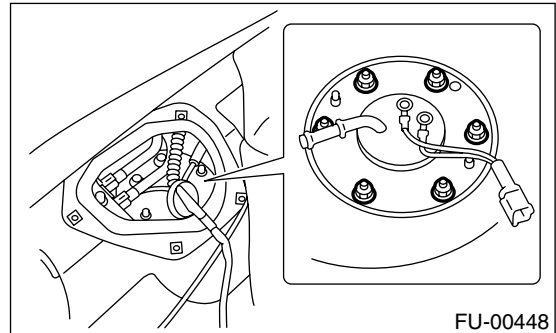

# FUEL FILTER

FUEL INJECTION (FUEL SYSTEMS)

## 27. Fuel Filter

### A: REMOVAL

#### WARNING:

- Place “NO FIRE” signs near the working area.
- Be careful not to spill fuel on the floor.

#### NOTE:

The fuel filter is built in fuel pump assembly.

- 1) Release the fuel pressure. <Ref. to FU(H6DO)-50, RELEASING OF FUEL PRESSURE, OPERATION, Fuel.>
- 2) Remove the fuel pump assembly. <Ref. to FU(H6DO)-68, REMOVAL, Fuel Pump.>
- 3) Disconnect the ground cable from filter holder.

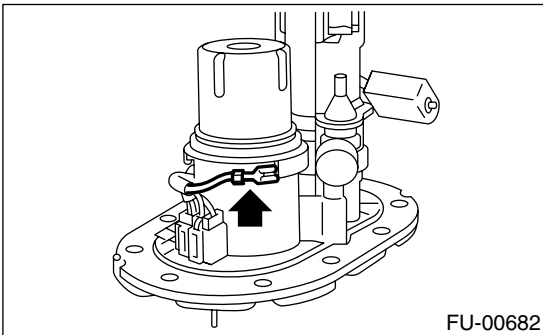

- 4) Remove the filter holder by turning it to the left from the body pawls, and then take out the filter.

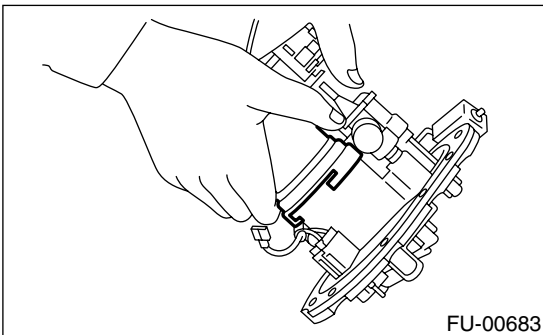

### B: INSTALLATION

#### NOTE:

- If the fuel hoses are damaged at the connecting portion, replace it with a new one.
- If the clamps are badly damaged, replace with new ones.
- Replace the o-ring with new ones.

- 1) Set the O-ring on the filter holder, and then install by turning to the right.

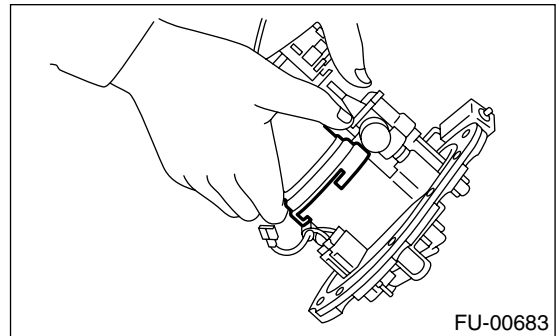

- 2) Connect the ground cable to filter holder.

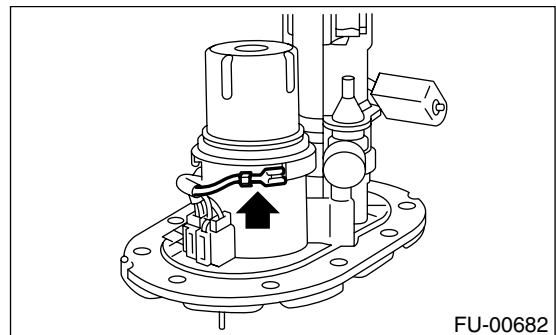

- 3) Install the fuel pump assembly. <Ref. to FU(H6DO)-68, INSTALLATION, Fuel Pump.>

### C: INSPECTION

- 1) Check the inside of fuel filter for dirt and water sediment.
- 2) If it is clogged, or if replacement interval has been reached, replace it.



## 28. Fuel Cut Valve

### A: REMOVAL

- 1) Remove fuel tank. <Ref. to FU(H6DO)-53, REMOVAL, Fuel Tank.>
- 2) Move clip and disconnect evaporation hose from fuel cut valve.

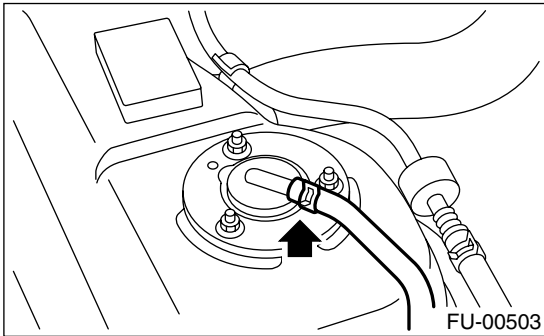

- 3) Remove bolts which install fuel cut valve.

### B: INSTALLATION

Install in the reverse order of removal.

#### **Tightening torque:**

**4.4 N·m (0.45 kgf·m, 3.3 ft-lb)**

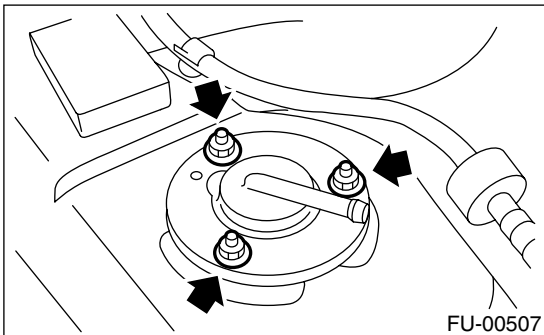

# FUEL DAMPER VALVE

FUEL INJECTION (FUEL SYSTEMS)

---

## 29. Fuel Damper Valve

### A: REMOVAL

1) Release fuel pressure. <Ref. to FU(H6DO)-50, RELEASING OF FUEL PRESSURE, OPERATION, Fuel.>

2) Remove fuel damper valve from fuel delivery and return lines.

### CAUTION:

Right and left portion of fuel damper valve are not identical. Do not confuse them when installing.

Right and left portion of fuel damper valve are colored differently on their upper side. The RH portion is colored olive, and the LH portion is colored yellow.

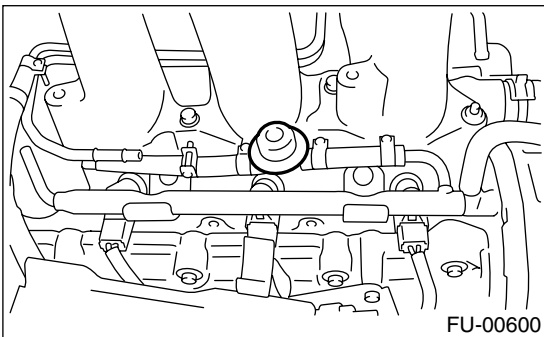

### B: INSTALLATION

Install in the reverse order of removal.

# FUEL DELIVERY, RETURN AND EVAPORATION LINES

FUEL INJECTION (FUEL SYSTEMS)

## 30. Fuel Delivery, Return and Evaporation Lines

### A: REMOVAL

- 1) Set vehicle on the lift.
- 2) Release fuel pressure. <Ref. to FU(H6DO)-50, RELEASING OF FUEL PRESSURE, OPERATION, Fuel.>
- 3) Open fuel filler flap lid and remove fuel filler cap.
- 4) Remove fuel tank. <Ref. to FU(H6DO)-53, REMOVAL, Fuel Tank.>
- 5) Remove fuel filler pipe. <Ref. to FU(H6DO)-61, REMOVAL, Fuel Filler Pipe.>
- 6) Remove floor mat. <Ref. to EI-60, REMOVAL, Floor Mat.>
- 7) Remove fuel delivery pipes and hoses, fuel return pipes and hoses, evaporation pipes and hoses.

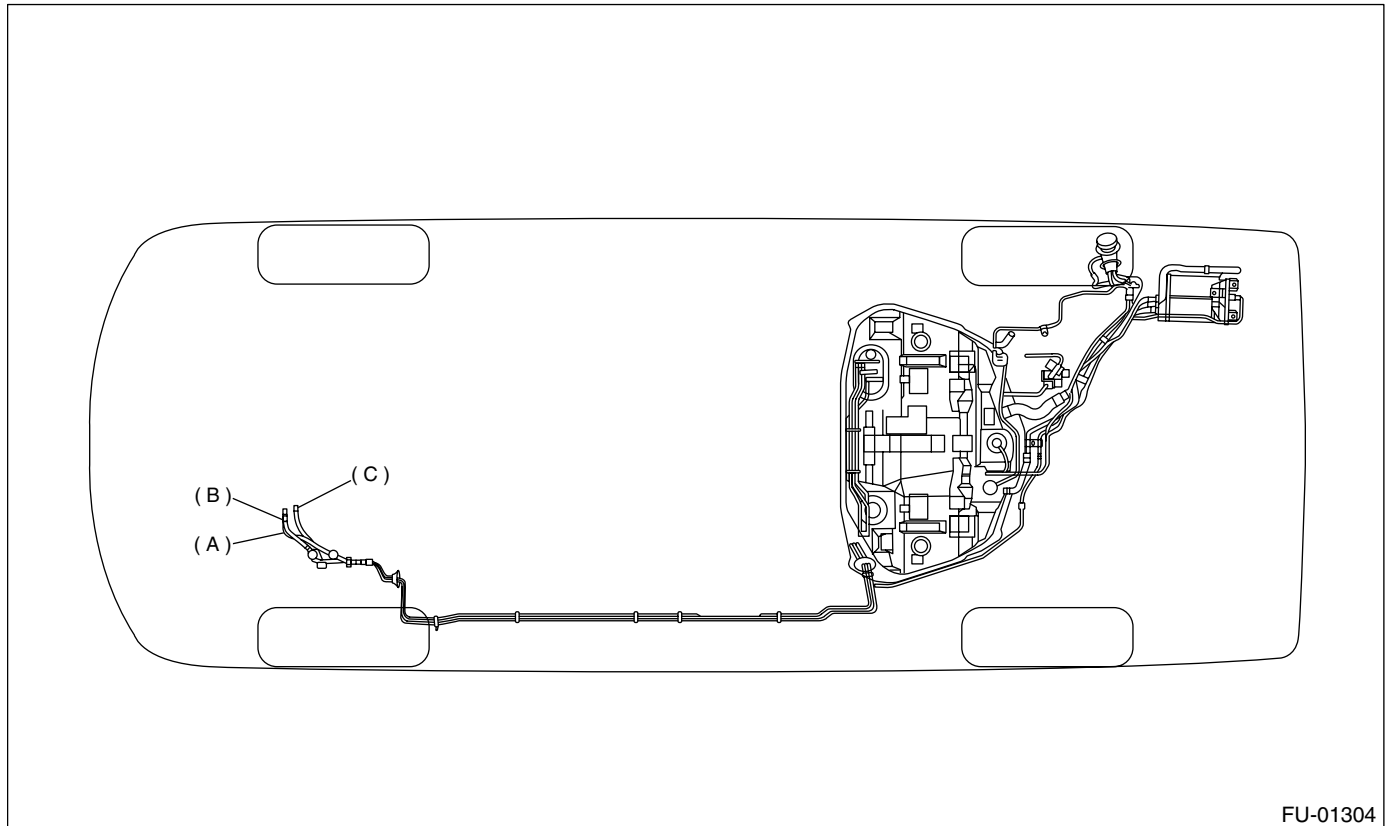

FU-01304

- (A) Fuel delivery line
- (B) Fuel return line
- (C) Fuel evaporation line

# FUEL DELIVERY, RETURN AND EVAPORATION LINES

## FUEL INJECTION (FUEL SYSTEMS)

8) In engine compartment, detach fuel delivery hoses, return hoses and evaporation hose.

(1) Separate quick connector of fuel delivery line and return line by pushing an ST in the direction of the arrow.

(2) Remove clips, and then separate evaporation hose from pipe.

ST 42099AE000 CONNECTOR REMOVER

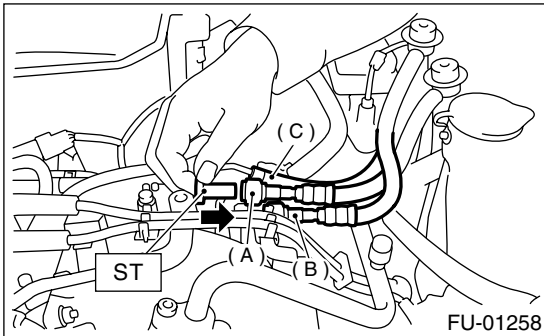

- (A) Fuel delivery hose
- (B) Fuel return hose
- (C) Fuel evaporation hose

9) Separate quick connector on fuel delivery and return line.

(1) Clean pipe and connector, if they are covered with dust.

(2) Hold connector (A) and push retainer (B) down.

(3) Pull out connector (A) from retainer (B).

### CAUTION:

Replace retainer with new ones.

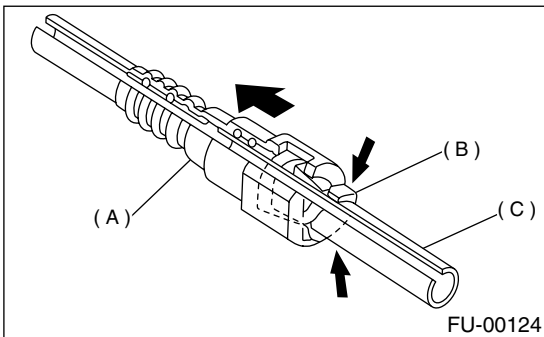

- (A) Connector
- (B) Retainer
- (C) Pipe

## B: INSTALLATION

1) Connect quick connector on fuel delivery and return line.

### CAUTION:

- Always use a new retainer.
- Make sure that the connected portion is not damaged or has dust. If necessary, clean seal surface (A) of pipe (B).

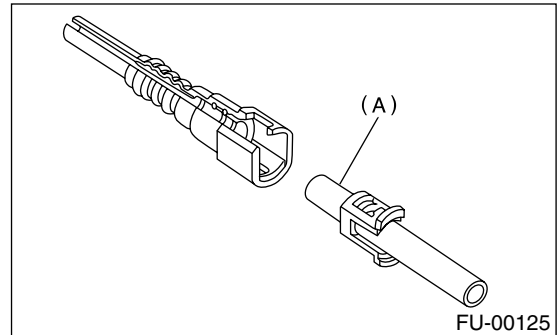

- (1) Set new retainer (B) to connector (A).
- (2) Push pipe into connector completely.

### NOTE:

At this time, two clicking sounds are heard.

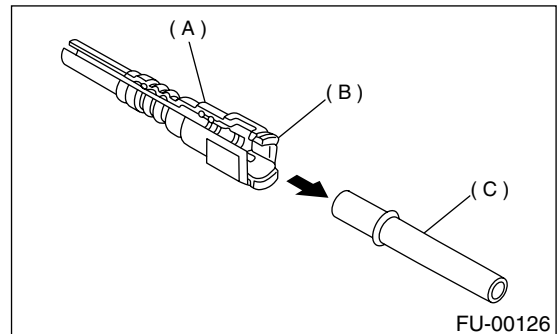

- (A) Connector
- (B) Retainer
- (C) Pipe

# FUEL DELIVERY, RETURN AND EVAPORATION LINES

FUEL INJECTION (FUEL SYSTEMS)

## CAUTION:

- Pull the connector to ensure it is connected securely.
- Ensure the two retainer pawls are engaged in their mating positions in the connector.
- Be sure to inspect hoses and their connections for any leakage of fuel.

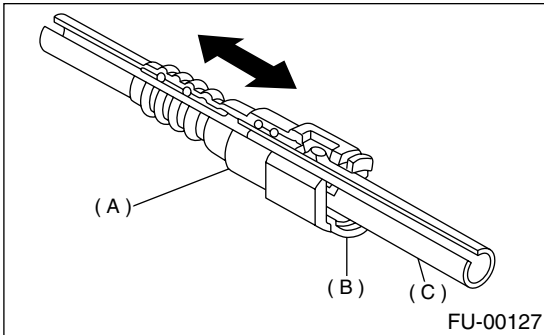

- (A) Connector
- (B) Retainer
- (C) Pipe

2) Connect fuel delivery hose to pipe with an overlap of 20 to 25 mm (0.79 to 0.98 in).

Type A: When fitting length is specified.

Type B: When fitting length is not specified.

$\phi : 2.5 \pm 1.5 \text{ mm } (0.098 \pm 0.059 \text{ in})$

$L : 22.5 \pm 2.5 \text{ mm } (0.886 \pm 0.098 \text{ in})$

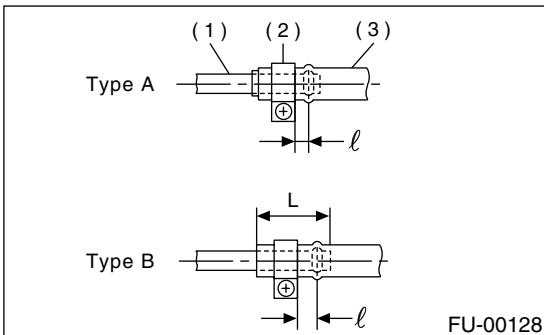

- (1) Pipe
- (2) Clamp
- (3) Hose

3) Connect evaporation hose to pipe by approx. 15 mm (0.59 in) from hose end.

$L = 17.5 \pm 2.5 \text{ mm } (0.689 \pm 0.098 \text{ in})$

## CAUTION:

Be sure to inspect hoses and their connections for any leakage of fuel.

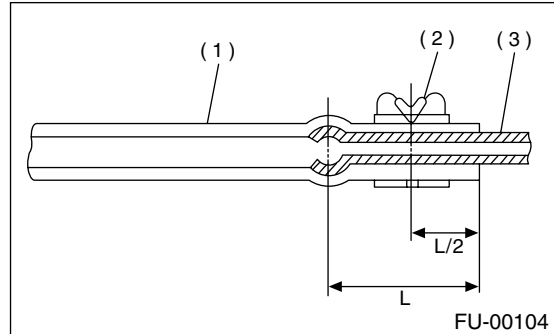

- (1) Hose
- (2) Clip
- (3) Pipe

## C: INSPECTION

1) Make sure that there are no cracks on the fuel pipes and fuel hoses.

2) Make sure that the fuel pipe and fuel hose connections are tight.

# FUEL SYSTEM TROUBLE IN GENERAL

## FUEL INJECTION (FUEL SYSTEMS)

### 31. Fuel System Trouble in General

#### A: INSPECTION

Trouble and possible cause		Corrective action
<b>1. Insufficient fuel supply to the injector</b>		
1)	Fuel pump will not operate.	
	○ Defective terminal contact.	Inspect connections, especially ground, and tighten securely.
	○ Trouble in electromagnetic or electronic circuit parts.	Replace fuel pump.
2)	Lowering of fuel pump function.	Replace fuel pump.
3)	Clogged dust or water in the fuel filter.	Replace fuel filter, clean or replace fuel tank.
4)	Clogged or bent fuel pipe or hose.	Clean, correct or replace fuel pipe or hose.
5)	Air is mixed in the fuel system.	Inspect or retighten each connection part.
6)	Clogged or bent breather tube or pipe.	Clean, correct or replace air breather tube or pipe.
7)	Damaged diaphragm of pressure regulator.	Replace.
<b>2. Leakage or blow out fuel</b>		
1)	Loosened joints of the fuel pipe.	Retightening.
2)	Cracked fuel pipe, hose and fuel tank.	Replace.
3)	Defective welding part on the fuel tank.	Replace.
4)	Defective drain packing of the fuel tank.	Replace.
5)	Clogged or bent air breather tube or air vent tube.	Clean, correct or replace air breather tube or air vent tube.
<b>3. Gasoline smell inside of compartment</b>		
1)	Loose joints at air breather tube, air vent tube and fuel filler pipe.	Retightening.
2)	Defective packing air tightness on the fuel saucer.	Correct or replace packing.
3)	Cracked fuel separator.	Replace separator.
4)	Inoperative fuel pump modulator or circuit.	Replace.
<b>4. Defective fuel meter indicator</b>		
1)	Defective operation of fuel level sensor.	Replace.
2)	Defective operation of fuel gauge.	Replace.
<b>5. Noise</b>		
1)	Large operation noise or vibration of fuel pump.	Replace.

**NOTE:**

- When the vehicle is left unattended for an extended period of time, water may accumulate in the fuel tank.

To prevent water condensation:

- (1) Top off the fuel tank or drain the fuel completely.
- (2) Drain water condensation from the fuel filter.

- Refilling the fuel tank.

Refill the fuel tank while there is still some fuel left in the tank.

- Protecting the fuel system against freezing and water condensation.

- (1) Cold areas

In snow-covered areas, mountainous areas, skiing areas, etc. where ambient temperatures drop below 0°C (32°F) throughout the winter season, use an anti-freeze solution in the fuel tank. Refueling will also complement the effect of anti-freeze solution each time the fuel level drops to about one-half. After the winter season,

drain water which may have accumulated in the fuel filter and fuel tank in the manner same as that described under damaged areas below.

(2) Affected areas

If water accumulated in the fuel filter, drain water from both the fuel filter and fuel tank or use a water removing agent (or anti-freeze solution) in the fuel tank.

- Observe the instructions, notes, etc., indicated on the label affixed to the anti-freeze solution (water removing agent) container before use.