

# GENERAL DESCRIPTION

# *GD(H6DO)*

---

	<b>Page</b>
1. List of Diagnostic Trouble Code (DTC) .....	2
2. Diagnostic Trouble Code (DTC) Detecting Criteria .....	10



# LIST OF DIAGNOSTIC TROUBLE CODE (DTC)

## GENERAL DESCRIPTION

### 1. List of Diagnostic Trouble Code (DTC)

#### A: LIST

DTC	Description	Index
P0030	HO2S Heater Control Circuit (Bank 1 Sensor 1)	<Ref. to GD(H6DO)-10, DTC P0030 — HO2S HEATER CONTROL CIRCUIT (BANK 1 SENSOR 1) —, Diagnostic Trouble Code (DTC) Detecting Criteria.>
P0031	HO2S Heater Control Circuit Low (Bank 1 Sensor 1)	<Ref. to GD(H6DO)-12, DTC P0031 — HO2S HEATER CONTROL CIRCUIT LOW (BANK 1 SENSOR 1) —, Diagnostic Trouble Code (DTC) Detecting Criteria.>
P0032	HO2S Heater Control Circuit High (Bank 1 Sensor 1)	<Ref. to GD(H6DO)-14, DTC P0032 — HO2S HEATER CONTROL CIRCUIT HIGH (BANK 1 SENSOR 1) —, Diagnostic Trouble Code (DTC) Detecting Criteria.>
P0037	HO2S Heater Control Circuit Low (Bank 1 Sensor 2)	<Ref. to GD(H6DO)-16, DTC P0037 — HO2S HEATER CONTROL CIRCUIT LOW (BANK 1 SENSOR 2) —, Diagnostic Trouble Code (DTC) Detecting Criteria.>
P0038	HO2S Heater Control Circuit High (Bank 1 Sensor 2)	<Ref. to GD(H6DO)-18, DTC P0038 — HO2S HEATER CONTROL CIRCUIT HIGH (BANK 1 SENSOR 2) —, Diagnostic Trouble Code (DTC) Detecting Criteria.>
P0050	HO2S Heater Control Circuit (Bank 2 Sensor 1)	<Ref. to GD(H6DO)-20, DTC P0050 — HO2S HEATER CONTROL CIRCUIT (BANK 2 SENSOR 1) —, Diagnostic Trouble Code (DTC) Detecting Criteria.>
P0051	HO2S Heater Control Circuit Low (Bank 2 Sensor 1)	<Ref. to GD(H6DO)-20, DTC P0051 — HO2S HEATER CONTROL CIRCUIT LOW (BANK 2 SENSOR 1) —, Diagnostic Trouble Code (DTC) Detecting Criteria.>
P0052	HO2S Heater Control Circuit High (Bank 2 Sensor 1)	<Ref. to GD(H6DO)-20, DTC P0052 — HO2S HEATER CONTROL CIRCUIT HIGH (BANK 2 SENSOR 1) —, Diagnostic Trouble Code (DTC) Detecting Criteria.>
P0068	Manifold Pressure Sensor Range/Performance	<Ref. to GD(H6DO)-22, DTC P0068 — MANIFOLD PRESSURE SENSOR RANGE/PERFORMANCE —, Diagnostic Trouble Code (DTC) Detecting Criteria.>
P0107	Manifold Absolute Pressure/Barometric Pressure Circuit Low Input	<Ref. to GD(H6DO)-26, DTC P0107 — MANIFOLD ABSOLUTE PRESSURE/BAROMETRIC PRESSURE CIRCUIT LOW INPUT —, Diagnostic Trouble Code (DTC) Detecting Criteria.>
P0108	Manifold Absolute Pressure/Barometric Pressure Circuit High Input	<Ref. to GD(H6DO)-28, DTC P0108 — MANIFOLD ABSOLUTE PRESSURE/BAROMETRIC PRESSURE CIRCUIT HIGH INPUT —, Diagnostic Trouble Code (DTC) Detecting Criteria.>
P0111	Intake Air Temperature Circuit Range/Performance	<Ref. to GD(H6DO)-30, DTC P0111 — INTAKE AIR TEMPERATURE CIRCUIT RANGE/PERFORMANCE —, Diagnostic Trouble Code (DTC) Detecting Criteria.>
P0112	Intake Air Temperature Circuit Low Input	<Ref. to GD(H6DO)-32, DTC P0112 — INTAKE AIR TEMPERATURE CIRCUIT LOW INPUT —, Diagnostic Trouble Code (DTC) Detecting Criteria.>
P0113	Intake Air Temperature Circuit High Input	<Ref. to GD(H6DO)-34, DTC P0113 — INTAKE AIR TEMPERATURE CIRCUIT HIGH INPUT —, Diagnostic Trouble Code (DTC) Detecting Criteria.>
P0117	Engine Coolant Temperature Circuit Low Input	<Ref. to GD(H6DO)-36, DTC P0117 — ENGINE COOLANT TEMPERATURE CIRCUIT LOW INPUT —, Diagnostic Trouble Code (DTC) Detecting Criteria.>
P0118	Engine Coolant Temperature Circuit High Input	<Ref. to GD(H6DO)-38, DTC P0118 — ENGINE COOLANT TEMPERATURE CIRCUIT HIGH INPUT —, Diagnostic Trouble Code (DTC) Detecting Criteria.>
P0121	Throttle/Pedal Position Sensor/Switch "A" Circuit Range/Performance	<Ref. to GD(H6DO)-40, DTC P0121 — THROTTLE/PEDAL POSITION SENSOR/SWITCH "A" CIRCUIT RANGE/PERFORMANCE —, Diagnostic Trouble Code (DTC) Detecting Criteria.>
P0122	Throttle/Pedal Position Sensor/Switch "A" Circuit Low Input	<Ref. to GD(H6DO)-44, DTC P0122 — THROTTLE/PEDAL POSITION SENSOR/SWITCH "A" CIRCUIT LOW INPUT —, Diagnostic Trouble Code (DTC) Detecting Criteria.>

# LIST OF DIAGNOSTIC TROUBLE CODE (DTC)

GENERAL DESCRIPTION

DTC	Description	Index
P0123	Throttle/Pedal Position Sensor/Switch "A" Circuit High Input	<Ref. to GD(H6DO)-46, DTC P0123 — THROTTLE/PEDAL POSITION SENSOR/SWITCH "A" CIRCUIT HIGH INPUT —, Diagnostic Trouble Code (DTC) Detecting Criteria.>
P0125	Insufficient Coolant Temperature For Closed Loop Fuel Control	<Ref. to GD(H6DO)-48, DTC P0125 — INSUFFICIENT COOLANT TEMPERATURE FOR CLOSED LOOP FUEL CONTROL —, Diagnostic Trouble Code (DTC) Detecting Criteria.>
P0128	Coolant Thermostat (Coolant Temperature Below Thermostat Regulating Temperature)	<Ref. to GD(H6DO)-52, DTC P0128 — COOLANT THERMOSTAT (COOLANT TEMPERATURE BELOW THERMOSTAT REGULATING TEMPERATURE) —, Diagnostic Trouble Code (DTC) Detecting Criteria.>
P0129	Barometric Pressure Too Low	<Ref. to GD(H6DO)-54, DTC P0129 — BAROMETRIC PRESSURE TOO LOW —, Diagnostic Trouble Code (DTC) Detecting Criteria.>
P0130	O <sub>2</sub> Sensor Circuit (Bank 1 Sensor 1)	<Ref. to GD(H6DO)-56, DTC P0130 — O <sub>2</sub> SENSOR CIRCUIT (BANK 1 SENSOR 1) —, Diagnostic Trouble Code (DTC) Detecting Criteria.>
P0133	O <sub>2</sub> Sensor Circuit Slow Response (Bank 1 Sensor 1)	<Ref. to GD(H6DO)-58, DTC P0133 — O <sub>2</sub> SENSOR CIRCUIT SLOW RESPONSE (BANK 1 SENSOR 1) —, Diagnostic Trouble Code (DTC) Detecting Criteria.>
P0134	O <sub>2</sub> Sensor Circuit No Activity Detected (Bank 1 Sensor 1)	<Ref. to GD(H6DO)-62, DTC P0134 — O <sub>2</sub> SENSOR CIRCUIT NO ACTIVITY DETECTED (BANK 1 SENSOR 1) —, Diagnostic Trouble Code (DTC) Detecting Criteria.>
P0137	O <sub>2</sub> Sensor Circuit Low Voltage (Bank 1 Sensor 2)	<Ref. to GD(H6DO)-64, DTC P0137 — O <sub>2</sub> SENSOR CIRCUIT LOW VOLTAGE (BANK 1 SENSOR 2) —, Diagnostic Trouble Code (DTC) Detecting Criteria.>
P0138	O <sub>2</sub> Sensor Circuit High Voltage (Bank 1 Sensor 2)	<Ref. to GD(H6DO)-66, DTC P0138 — O <sub>2</sub> SENSOR CIRCUIT HIGH VOLTAGE (BANK 1 SENSOR 2) —, Diagnostic Trouble Code (DTC) Detecting Criteria.>
P0139	O <sub>2</sub> Sensor Circuit Slow Response (Bank 1 Sensor 2)	<Ref. to GD(H6DO)-68, DTC P0139 — O <sub>2</sub> SENSOR CIRCUIT SLOW RESPONSE (BANK 1 SENSOR 2) —, Diagnostic Trouble Code (DTC) Detecting Criteria.>
P0150	O <sub>2</sub> Sensor Circuit (Bank 2 Sensor 1)	<Ref. to GD(H6DO)-71, DTC P0150 — O <sub>2</sub> SENSOR CIRCUIT (BANK 1 SENSOR 1) —, Diagnostic Trouble Code (DTC) Detecting Criteria.>
P0153	O <sub>2</sub> Sensor Circuit Slow Response (Bank 2 Sensor 1)	<Ref. to GD(H6DO)-71, DTC P0153 — O <sub>2</sub> SENSOR CIRCUIT SLOW RESPONSE (BANK 2 SENSOR 1) —, Diagnostic Trouble Code (DTC) Detecting Criteria.>
P0154	O <sub>2</sub> Sensor Circuit No Activity Detected (Bank 2 Sensor 1)	<Ref. to GD(H6DO)-71, DTC P0154 — O <sub>2</sub> SENSOR CIRCUIT NO ACTIVITY DETECTED (BANK 2 SENSOR 1) —, Diagnostic Trouble Code (DTC) Detecting Criteria.>
P0171	System Too Lean (Bank 1)	<Ref. to GD(H6DO)-72, DTC P0171 — SYSTEM TOO LEAN (BANK 1) —, Diagnostic Trouble Code (DTC) Detecting Criteria.>
P0172	System Too Rich (Bank 1)	<Ref. to GD(H6DO)-76, DTC P0172 — SYSTEM TOO RICH (BANK 1) —, Diagnostic Trouble Code (DTC) Detecting Criteria.>
P0174	System too Lean (Bank 2)	<Ref. to GD(H6DO)-79, DTC P0174 — SYSTEM TOO LEAN (BANK 2) —, Diagnostic Trouble Code (DTC) Detecting Criteria.>
P0175	System too Rich (Bank 2)	<Ref. to GD(H6DO)-79, DTC P0175 — SYSTEM TOO RICH (BANK 2) —, Diagnostic Trouble Code (DTC) Detecting Criteria.>
P0181	Fuel Temperature Sensor "A" Circuit Range/Performance	<Ref. to GD(H6DO)-80, DTC P0181 — FUEL TEMPERATURE SENSOR "A" CIRCUIT RANGE/PERFORMANCE —, Diagnostic Trouble Code (DTC) Detecting Criteria.>
P0182	Fuel Temperature Sensor "A" Circuit Low Input	<Ref. to GD(H6DO)-84, DTC P0182 — FUEL TEMPERATURE SENSOR "A" CIRCUIT LOW INPUT —, Diagnostic Trouble Code (DTC) Detecting Criteria.>
P0183	Fuel Temperature Sensor "A" Circuit High Input	<Ref. to GD(H6DO)-86, DTC P0183 — FUEL TEMPERATURE SENSOR "A" CIRCUIT HIGH INPUT —, Diagnostic Trouble Code (DTC) Detecting Criteria.>
P0230	Fuel Pump Primary Circuit	<Ref. to GD(H6DO)-88, DTC P0230 — FUEL PUMP PRIMARY CIRCUIT —, Diagnostic Trouble Code (DTC) Detecting Criteria.>
P0301	Cylinder 1 Misfire Detected	<Ref. to GD(H6DO)-90, DTC P0301 — CYLINDER 1 MISFIRE DETECTED —, Diagnostic Trouble Code (DTC) Detecting Criteria.>

# LIST OF DIAGNOSTIC TROUBLE CODE (DTC)

## GENERAL DESCRIPTION

DTC	Description	Index
P0302	Cylinder 2 Misfire Detected	<Ref. to GD(H6DO)-96, DTC P0302 — CYLINDER 2 MISFIRE DETECTED —, Diagnostic Trouble Code (DTC) Detecting Criteria.>
P0303	Cylinder 3 Misfire Detected	<Ref. to GD(H6DO)-96, DTC P0303 — CYLINDER 3 MISFIRE DETECTED —, Diagnostic Trouble Code (DTC) Detecting Criteria.>
P0304	Cylinder 4 Misfire Detected	<Ref. to GD(H6DO)-96, DTC P0304 — CYLINDER 4 MISFIRE DETECTED —, Diagnostic Trouble Code (DTC) Detecting Criteria.>
P0305	Cylinder 5 Misfire Detected	<Ref. to GD(H6DO)-96, DTC P0305 — CYLINDER 5 MISFIRE DETECTED —, Diagnostic Trouble Code (DTC) Detecting Criteria.>
P0306	Cylinder 6 Misfire Detected	<Ref. to GD(H6DO)-96, DTC P0306 — CYLINDER 6 MISFIRE DETECTED —, Diagnostic Trouble Code (DTC) Detecting Criteria.>
P0327	Knock Sensor 1 Circuit Low Input (Bank 1 or Single Sensor)	<Ref. to GD(H6DO)-98, DTC P0327 — KNOCK SENSOR 1 CIRCUIT LOW INPUT (BANK 1 OR SINGLE SENSOR) —, Diagnostic Trouble Code (DTC) Detecting Criteria.>
P0328	Knock Sensor 1 Circuit High Input (Bank 1 or Single Sensor)	<Ref. to GD(H6DO)-100, DTC P0328 — KNOCK SENSOR 1 CIRCUIT HIGH INPUT (BANK 1 OR SINGLE SENSOR) —, Diagnostic Trouble Code (DTC) Detecting Criteria.>
P0332	Knock Sensor 2 Circuit Low Input (Bank 2)	<Ref. to GD(H6DO)-102, DTC P0332 — KNOCK SENSOR 2 CIRCUIT LOW INPUT (BANK 2) —, Diagnostic Trouble Code (DTC) Detecting Criteria.>
P0333	Knock Sensor 2 Circuit High Input (Bank 2)	<Ref. to GD(H6DO)-102, DTC P0333 — KNOCK SENSOR 2 CIRCUIT HIGH INPUT (BANK 2) —, Diagnostic Trouble Code (DTC) Detecting Criteria.>
P0335	Crankshaft Position Sensor "A" Circuit	<Ref. to GD(H6DO)-104, DTC P0335 — CRANKSHAFT POSITION SENSOR "A" CIRCUIT —, Diagnostic Trouble Code (DTC) Detecting Criteria.>
P0336	Crankshaft Position Sensor "A" Circuit Range/Performance	<Ref. to GD(H6DO)-106, DTC P0336 — CRANKSHAFT POSITION SENSOR "A" CIRCUIT RANGE/PERFORMANCE —, Diagnostic Trouble Code (DTC) Detecting Criteria.>
P0340	Camshaft Position Sensor "A" Circuit (Bank 1 or Single Sensor)	<Ref. to GD(H6DO)-108, DTC P0340 — CAMSHAFT POSITION SENSOR "A" CIRCUIT (BANK 1 OR SINGLE SENSOR) —, Diagnostic Trouble Code (DTC) Detecting Criteria.>
P0341	Camshaft Position Sensor "A" Circuit Range/Performance (Bank 1 or Single Sensor)	<Ref. to GD(H6DO)-111, ECM OPERATING AT DTC SETTING, Diagnostic Trouble Code (DTC) Detecting Criteria.>
P0400	Exhaust Gas Recirculation Flow	<Ref. to GD(H6DO)-112, DTC P0400 — EXHAUST GAS RECIRCULATION FLOW —, Diagnostic Trouble Code (DTC) Detecting Criteria.>
P0420	Catalyst System Efficiency Below Threshold (Bank 1)	<Ref. to GD(H6DO)-116, DTC P0420 — CATALYST SYSTEM EFFICIENCY BELOW THRESHOLD (BANK 1) —, Diagnostic Trouble Code (DTC) Detecting Criteria.>
P0442	Evaporative Emission Control System Leak Detected (Small Leak)	<Ref. to GD(H6DO)-120, DTC P0442 — EVAPORATIVE EMISSION CONTROL SYSTEM LEAK DETECTED (SMALL LEAK) —, Diagnostic Trouble Code (DTC) Detecting Criteria.>
P0447	Evaporative Emission Control System Vent Control Circuit Open	<Ref. to GD(H6DO)-140, DTC P0447 — EVAPORATIVE EMISSION CONTROL SYSTEM VENT CONTROL CIRCUIT OPEN —, Diagnostic Trouble Code (DTC) Detecting Criteria.>
P0448	Evaporative Emission Control System Vent Control Circuit Shorted	<Ref. to GD(H6DO)-142, DTC P0448 — EVAPORATIVE EMISSION CONTROL SYSTEM VENT CONTROL CIRCUIT SHORTED —, Diagnostic Trouble Code (DTC) Detecting Criteria.>
P0451	Evaporative Emission Control System Pressure Sensor Range/Performance	<Ref. to GD(H6DO)-144, DTC P0451 — EVAPORATIVE EMISSION CONTROL SYSTEM PRESSURE SENSOR RANGE/PERFORMANCE —, Diagnostic Trouble Code (DTC) Detecting Criteria.>
P0452	Evaporative Emission Control System Pressure Sensor Low Input	<Ref. to GD(H6DO)-146, DTC P0452 — EVAPORATIVE EMISSION CONTROL SYSTEM PRESSURE SENSOR LOW INPUT —, Diagnostic Trouble Code (DTC) Detecting Criteria.>
P0453	Evaporative Emission Control System Pressure Sensor High Input	<Ref. to GD(H6DO)-148, DTC P0453 — EVAPORATIVE EMISSION CONTROL SYSTEM PRESSURE SENSOR HIGH INPUT —, Diagnostic Trouble Code (DTC) Detecting Criteria.>

# LIST OF DIAGNOSTIC TROUBLE CODE (DTC)

GENERAL DESCRIPTION

DTC	Description	Index
P0456	Evaporative Emission Control System Leak Detected (Very Small Leak)	<Ref. to GD(H6DO)-150, DTC P0456 — EVAPORATIVE EMISSION CONTROL SYSTEM LEAK DETECTED (VERY SMALL LEAK) —, Diagnostic Trouble Code (DTC) Detecting Criteria.>
P0457	Evaporative Emission Control System Leak Detected (Fuel Cap Loose/Off)	<Ref. to GD(H6DO)-150, DTC P0457 — EVAPORATIVE EMISSION CONTROL SYSTEM LEAK DETECTED (FUEL CAP LOOSE/OFF) —, Diagnostic Trouble Code (DTC) Detecting Criteria.>
P0458	Evaporative Emission Control System Purge Control Valve Circuit Low	<Ref. to GD(H6DO)-152, DTC P0458 — EVAPORATIVE EMISSION CONTROL SYSTEM PURGE CONTROL VALVE CIRCUIT LOW —, Diagnostic Trouble Code (DTC) Detecting Criteria.>
P0459	Evaporative Emission Control System Purge Control Valve Circuit High	<Ref. to GD(H6DO)-154, DTC P0459 — EVAPORATIVE EMISSION CONTROL SYSTEM PURGE CONTROL VALVE CIRCUIT HIGH —, Diagnostic Trouble Code (DTC) Detecting Criteria.>
P0461	Fuel Level Sensor Circuit Range/Performance	<Ref. to GD(H6DO)-156, DTC P0461 — FUEL LEVEL SENSOR CIRCUIT RANGE/PERFORMANCE —, Diagnostic Trouble Code (DTC) Detecting Criteria.>
P0462	Fuel Level Sensor Circuit Low Input	<Ref. to GD(H6DO)-158, DTC P0462 — FUEL LEVEL SENSOR CIRCUIT LOW INPUT —, Diagnostic Trouble Code (DTC) Detecting Criteria.>
P0463	Fuel Level Sensor Circuit High Input	<Ref. to GD(H6DO)-160, DTC P0463 — FUEL LEVEL SENSOR CIRCUIT HIGH INPUT —, Diagnostic Trouble Code (DTC) Detecting Criteria.>
P0464	Fuel Level Sensor Circuit Intermittent	<Ref. to GD(H6DO)-162, DTC P0464 — FUEL LEVEL SENSOR CIRCUIT INTERMITTENT —, Diagnostic Trouble Code (DTC) Detecting Criteria.>
P0483	Cooling Fan Rationality Check	<Ref. to GD(H6DO)-166, DTC P0483 — COOLING FAN RATIONALITY CHECK —, Diagnostic Trouble Code (DTC) Detecting Criteria.>
P0502	Vehicle Speed Sensor Circuit Low Input	<Ref. to GD(H6DO)-167, DTC P0502 — VEHICLE SPEED SENSOR CIRCUIT LOW INPUT —, Diagnostic Trouble Code (DTC) Detecting Criteria.>
P0503	Vehicle Speed Sensor Intermittent/Erratic/High	<Ref. to GD(H6DO)-168, DTC P0503 — VEHICLE SPEED SENSOR INTERMITTENT/ERRATIC/HIGH —, Diagnostic Trouble Code (DTC) Detecting Criteria.>
P0506	Idle Control System Rpm Lower Than Expected	<Ref. to GD(H6DO)-170, DTC P0506 — IDLE CONTROL SYSTEM RPM LOWER THAN EXPECTED —, Diagnostic Trouble Code (DTC) Detecting Criteria.>
P0507	Idle Control System Rpm Higher Than Expected	<Ref. to GD(H6DO)-172, DTC P0507 — IDLE CONTROL SYSTEM RPM HIGHER THAN EXPECTED —, Diagnostic Trouble Code (DTC) Detecting Criteria.>
P0508	Idle Control System Circuit Low	<Ref. to GD(H6DO)-174, DTC P0508 — IDLE CONTROL SYSTEM CIRCUIT LOW —, Diagnostic Trouble Code (DTC) Detecting Criteria.>
P0509	Idle Control System Circuit High	<Ref. to GD(H6DO)-176, DTC P0509 — IDLE CONTROL SYSTEM CIRCUIT HIGH —, Diagnostic Trouble Code (DTC) Detecting Criteria.>
P0512	Starter Request Circuit	<Ref. to GD(H6DO)-178, DTC P0512 — STARTER REQUEST CIRCUIT —, Diagnostic Trouble Code (DTC) Detecting Criteria.>
P0519	Idle Control System Malfunction (Fail-Safe)	<Ref. to GD(H6DO)-180, DTC P0519 — IDLE CONTROL SYSTEM MALFUNCTION (FAIL-SAFE) —, Diagnostic Trouble Code (DTC) Detecting Criteria.>
P0565	Cruise Control ON Signal	<Ref. to GD(H6DO)-182, DTC P0565 — CRUISE CONTROL ON SIGNAL —, Diagnostic Trouble Code (DTC) Detecting Criteria.>
P0604	Internal Control Module Random Access Memory (RAM) Error	<Ref. to GD(H6DO)-183, DTC P0604 — INTERNAL CONTROL MODULE RANDOM ACCESS MEMORY (RAM) ERROR —, Diagnostic Trouble Code (DTC) Detecting Criteria.>
P0661	Intake Manifold Tuning Valve Control Circuit Low — Bank 1	<Ref. to GD(H6DO)-184, DTC P0661 — INTAKE MANIFOLD TUNING VALVE CONTROL CIRCUIT LOW — BANK 1 —, Diagnostic Trouble Code (DTC) Detecting Criteria.>
P0662	Intake Manifold Tuning Valve Control Circuit High — Bank 1	<Ref. to GD(H6DO)-186, DTC P0662 — INTAKE MANIFOLD TUNING VALVE CONTROL CIRCUIT HIGH — BANK 1 —, Diagnostic Trouble Code (DTC) Detecting Criteria.>
P0691	Cooling Fan 1 Control Circuit Low	<Ref. to GD(H6DO)-188, DTC P0691 — COOLING FAN 1 CONTROL CIRCUIT LOW —, Diagnostic Trouble Code (DTC) Detecting Criteria.>

# LIST OF DIAGNOSTIC TROUBLE CODE (DTC)

## GENERAL DESCRIPTION

DTC	Description	Index
P0692	Cooling Fan 1 Control Circuit High	<Ref. to GD(H6DO)-189, DTC P0692 — COOLING FAN 1 CONTROL CIRCUIT HIGH —, Diagnostic Trouble Code (DTC) Detecting Criteria.>
P0703	Torque Converter/Brake Switch “B” Circuit	<Ref. to GD(H6DO)-190, DTC P0703 — TORQUE CONVERTER/BRAKE SWITCH “B” CIRCUIT —, Diagnostic Trouble Code (DTC) Detecting Criteria.>
P0705	Transmission Range Sensor Circuit (PRNDL Input)	<Ref. to GD(H6DO)-191, DTC P0705 — TRANSMISSION RANGE SENSOR CIRCUIT (PRNDL INPUT) —, Diagnostic Trouble Code (DTC) Detecting Criteria.>
P0710	Transmission Fluid Temperature Sensor Circuit	<Ref. to GD(H6DO)-192, DTC P0710 — TRANSMISSION FLUID TEMPERATURE SENSOR CIRCUIT —, Diagnostic Trouble Code (DTC) Detecting Criteria.>
P0716	Input/Turbine Speed Sensor Circuit Range/Performance	<Ref. to GD(H6DO)-193, DTC P0716 — INPUT/TURBINE SPEED SENSOR CIRCUIT RANGE/PERFORMANCE —, Diagnostic Trouble Code (DTC) Detecting Criteria.>
P0720	Output Speed Sensor Circuit	<Ref. to GD(H6DO)-194, DTC P0720 — OUTPUT SPEED SENSOR CIRCUIT —, Diagnostic Trouble Code (DTC) Detecting Criteria.>
P0726	Engine Speed Input Circuit Range/Performance	<Ref. to GD(H6DO)-195, DTC P0726 — ENGINE SPEED INPUT CIRCUIT RANGE/PERFORMANCE —, Diagnostic Trouble Code (DTC) Detecting Criteria.>
P0731	Gear 1 Incorrect Ratio	<Ref. to GD(H6DO)-196, DTC P0731 — GEAR 1 INCORRECT RATIO —, Diagnostic Trouble Code (DTC) Detecting Criteria.>
P0732	Gear 2 Incorrect Ratio	<Ref. to GD(H6DO)-197, DTC P0732 — GEAR 2 INCORRECT RATIO —, Diagnostic Trouble Code (DTC) Detecting Criteria.>
P0733	Gear 3 Incorrect Ratio	<Ref. to GD(H6DO)-198, DTC P0733 — GEAR 3 INCORRECT RATIO —, Diagnostic Trouble Code (DTC) Detecting Criteria.>
P0734	Gear 4 Incorrect Ratio	<Ref. to GD(H6DO)-199, DTC P0734 — GEAR 4 INCORRECT RATIO —, Diagnostic Trouble Code (DTC) Detecting Criteria.>
P0741	Torque Converter Clutch Circuit Performance or Stuck OFF	<Ref. to GD(H6DO)-200, DTC P0741 — TORQUE CONVERTER CLUTCH CIRCUIT PERFORMANCE OR STUCK OFF —, Diagnostic Trouble Code (DTC) Detecting Criteria.>
P0743	Torque Converter Clutch Circuit Electrical	<Ref. to GD(H6DO)-201, DTC P0743 — TORQUE CONVERTER CLUTCH CIRCUIT ELECTRICAL —, Diagnostic Trouble Code (DTC) Detecting Criteria.>
P0748	Pressure Control Solenoid “A” Electrical	<Ref. to GD(H6DO)-202, DTC P0748 — PRESSURE CONTROL SOLENOID “A” ELECTRICAL —, Diagnostic Trouble Code (DTC) Detecting Criteria.>
P0753	Shift Solenoid “A” Electrical	<Ref. to GD(H6DO)-203, DTC P0753 — SHIFT SOLENOID “A” ELECTRICAL —, Diagnostic Trouble Code (DTC) Detecting Criteria.>
P0758	Shift Solenoid “B” Electrical	<Ref. to GD(H6DO)-204, DTC P0758 — SHIFT SOLENOID “B” ELECTRICAL —, Diagnostic Trouble Code (DTC) Detecting Criteria.>
P0771	Shift Solenoid “E” Performance or Stuck OFF	<Ref. to GD(H6DO)-205, DTC P0771 — SHIFT SOLENOID “E” PERFORMANCE OR STUCK OFF —, Diagnostic Trouble Code (DTC) Detecting Criteria.>
P0778	Pressure Control Solenoid “B” Electrical	<Ref. to GD(H6DO)-206, DTC P0778 — PRESSURE CONTROL SOLENOID “B” ELECTRICAL —, Diagnostic Trouble Code (DTC) Detecting Criteria.>
P0785	Shift/Timing Solenoid	<Ref. to GD(H6DO)-207, DTC P0785 — SHIFT/TIMING SOLENOID —, Diagnostic Trouble Code (DTC) Detecting Criteria.>
P0851	Neutral Switch Input Circuit Low	<Ref. to GD(H6DO)-208, DTC P0851 — NEUTRAL SWITCH INPUT CIRCUIT LOW —, Diagnostic Trouble Code (DTC) Detecting Criteria.>
P0852	Neutral Switch Input Circuit High	<Ref. to GD(H6DO)-209, DTC P0852 — NEUTRAL SWITCH INPUT CIRCUIT HIGH —, Diagnostic Trouble Code (DTC) Detecting Criteria.>
P0864	TCM Communication Circuit Range/Performance	<Ref. to GD(H6DO)-210, DTC P0864 — TCM COMMUNICATION CIRCUIT RANGE/PERFORMANCE —, Diagnostic Trouble Code (DTC) Detecting Criteria.>
P0865	TCM Communication Circuit Low	<Ref. to GD(H6DO)-211, DTC P0865 — TCM COMMUNICATION CIRCUIT LOW —, Diagnostic Trouble Code (DTC) Detecting Criteria.>

# LIST OF DIAGNOSTIC TROUBLE CODE (DTC)

GENERAL DESCRIPTION

DTC	Description	Index
P0866	TCM Communication Circuit High	<Ref. to GD(H6DO)-212, DTC P0866 — TCM COMMUNICATION CIRCUIT HIGH —, Diagnostic Trouble Code (DTC) Detecting Criteria.>
P1110	Atmospheric Pressure Sensor Circuit Malfunction (Low Input)	<Ref. to GD(H6DO)-213, DTC P1110 — ATMOSPHERIC PRESSURE SENSOR CIRCUIT MALFUNCTION (LOW INPUT) —, Diagnostic Trouble Code (DTC) Detecting Criteria.>
P1111	Atmospheric Pressure Sensor Circuit Malfunction (High Input)	<Ref. to GD(H6DO)-214, DTC P1111 — ATMOSPHERIC PRESSURE SENSOR CIRCUIT MALFUNCTION (HIGH INPUT) —, Diagnostic Trouble Code (DTC) Detecting Criteria.>
P1134	A/F Sensor Micro-Computer Problem	<Ref. to GD(H6DO)-216, DTC P1134 — A/F SENSOR MICRO-COMPUTER PROBLEM —, Diagnostic Trouble Code (DTC) Detecting Criteria.>
P1152	O <sub>2</sub> Sensor Circuit Range/Performance (Low) (Bank 1 Sensor 1)	<Ref. to GD(H6DO)-218, DTC P1152 — O <sub>2</sub> SENSOR CIRCUIT RANGE/PERFORMANCE (LOW) (BANK 1 SENSOR 1) —, Diagnostic Trouble Code (DTC) Detecting Criteria.>
P1153	O <sub>2</sub> Sensor Circuit Range/Performance (High) (Bank 1 Sensor 1)	<Ref. to GD(H6DO)-222, DTC P1153 — O <sub>2</sub> SENSOR CIRCUIT RANGE/PERFORMANCE (HIGH) (BANK 1 SENSOR 1) —, Diagnostic Trouble Code (DTC) Detecting Criteria.>
P1154	O <sub>2</sub> Sensor Circuit Range/Performance (Low) (Bank 2 Sensor 1)	<Ref. to GD(H6DO)-225, DTC P1154 — O <sub>2</sub> SENSOR CIRCUIT RANGE/PERFORMANCE (LOW) (BANK 2 SENSOR 1) —, Diagnostic Trouble Code (DTC) Detecting Criteria.>
P1155	O <sub>2</sub> Sensor Circuit Range/Performance (High) (Bank 2 Sensor 1)	<Ref. to GD(H6DO)-225, DTC P1155 — O <sub>2</sub> SENSOR CIRCUIT RANGE/PERFORMANCE (HIGH) (BANK 2 SENSOR 1) —, Diagnostic Trouble Code (DTC) Detecting Criteria.>
P1400	Fuel Tank Pressure Control Solenoid Valve Circuit Low	<Ref. to GD(H6DO)-226, DTC P1400 — FUEL TANK PRESSURE CONTROL SOLENOID VALVE CIRCUIT LOW —, Diagnostic Trouble Code (DTC) Detecting Criteria.>
P1420	Fuel Tank Pressure Control Sol. Valve Circuit High	<Ref. to GD(H6DO)-228, DTC P1420 — FUEL TANK PRESSURE CONTROL SOL. VALVE CIRCUIT HIGH —, Diagnostic Trouble Code (DTC) Detecting Criteria.>
P1443	Vent Control Solenoid Valve Function Problem	<Ref. to GD(H6DO)-230, DTC P1443 — VENT CONTROL SOLENOID VALVE FUNCTION PROBLEM —, Diagnostic Trouble Code (DTC) Detecting Criteria.>
P1446	Fuel Tank Sensor Control Valve Circuit Low	<Ref. to GD(H6DO)-232, DTC P1446 — FUEL TANK SENSOR CONTROL VALVE CIRCUIT LOW —, Diagnostic Trouble Code (DTC) Detecting Criteria.>
P1447	Fuel Tank Sensor Control Valve Circuit High	<Ref. to GD(H6DO)-234, DTC P1447 — FUEL TANK SENSOR CONTROL VALVE CIRCUIT HIGH —, Diagnostic Trouble Code (DTC) Detecting Criteria.>
P1448	Fuel Tank Sensor Control Valve Range Performance	<Ref. to GD(H6DO)-236, DTC P1448 — FUEL TANK SENSOR CONTROL VALVE RANGE PERFORMANCE —, Diagnostic Trouble Code (DTC) Detecting Criteria.>
P1518	Starter Switch Circuit Low Input	<Ref. to GD(H6DO)-240, DTC P1518 — STARTER SWITCH CIRCUIT LOW INPUT —, Diagnostic Trouble Code (DTC) Detecting Criteria.>
P1560	Back-Up Voltage Circuit Malfunction	<Ref. to GD(H6DO)-241, DTC P1560 — BACK-UP VOLTAGE CIRCUIT MALFUNCTION —, Diagnostic Trouble Code (DTC) Detecting Criteria.>
P1698	Engine Torque Control Cut Signal Circuit Malfunction (Low Input)	<Ref. to GD(H6DO)-242, DTC P1698 — ENGINE TORQUE CONTROL CUT SIGNAL CIRCUIT MALFUNCTION (LOW INPUT) —, Diagnostic Trouble Code (DTC) Detecting Criteria.>
P1699	Engine Torque Control Cut Signal Circuit Malfunction (High Input)	<Ref. to GD(H6DO)-243, DTC P1699 — ENGINE TORQUE CONTROL CUT SIGNAL CIRCUIT MALFUNCTION (HIGH INPUT) —, Diagnostic Trouble Code (DTC) Detecting Criteria.>
P1700	Throttle Position Sensor Circuit Malfunction For AT	<Ref. to GD(H6DO)-244, DTC P1700 — THROTTLE POSITION SENSOR CIRCUIT MALFUNCTION FOR AT —, Diagnostic Trouble Code (DTC) Detecting Criteria.>
P1711	Engine Torque Control Signal #1 Circuit Malfunction	<Ref. to GD(H6DO)-246, DTC P1711 — ENGINE TORQUE CONTROL SIGNAL #1 CIRCUIT MALFUNCTION —, Diagnostic Trouble Code (DTC) Detecting Criteria.>

# LIST OF DIAGNOSTIC TROUBLE CODE (DTC)

## GENERAL DESCRIPTION

DTC	Description	Index
P1712	Engine Torque Control Signal #2 Circuit Malfunction	<Ref. to GD(H6DO)-247, DTC P1712 — ENGINE TORQUE CONTROL SIGNAL #2 CIRCUIT MALFUNCTION —, Diagnostic Trouble Code (DTC) Detecting Criteria.>
P2096	Post Catalyst Fuel Trim System Too Lean Bank 1	<Ref. to GD(H6DO)-248, DTC P2096 — POST CATALYST FUEL TRIM SYSTEM TOO LEAN BANK 1 —, Diagnostic Trouble Code (DTC) Detecting Criteria.>
P2097	Post Catalyst Fuel Trim System Too Rich Bank 1	<Ref. to GD(H6DO)-250, DTC P2097 — POST CATALYST FUEL TRIM SYSTEM TOO RICH BANK 1 —, Diagnostic Trouble Code (DTC) Detecting Criteria.>



# LIST OF DIAGNOSTIC TROUBLE CODE (DTC)

GENERAL DESCRIPTION

---

MEMO:

# DIAGNOSTIC TROUBLE CODE (DTC) DETECTING CRITERIA

## GENERAL DESCRIPTION

## 2. Diagnostic Trouble Code (DTC) Detecting Criteria

### A: DTC P0030 — HO<sub>2</sub>S HEATER CONTROL CIRCUIT (BANK 1 SENSOR 1) —

#### 1. OUTLINE OF DIAGNOSIS

Detect the malfunction of front oxygen (A/F) sensor heater.

Judge NG when impedance of front oxygen (A/F) sensor is larger than the standard value by referring to the engine condition such as fuel shut-off in deceleration, etc.

#### 2. COMPONENT DESCRIPTION

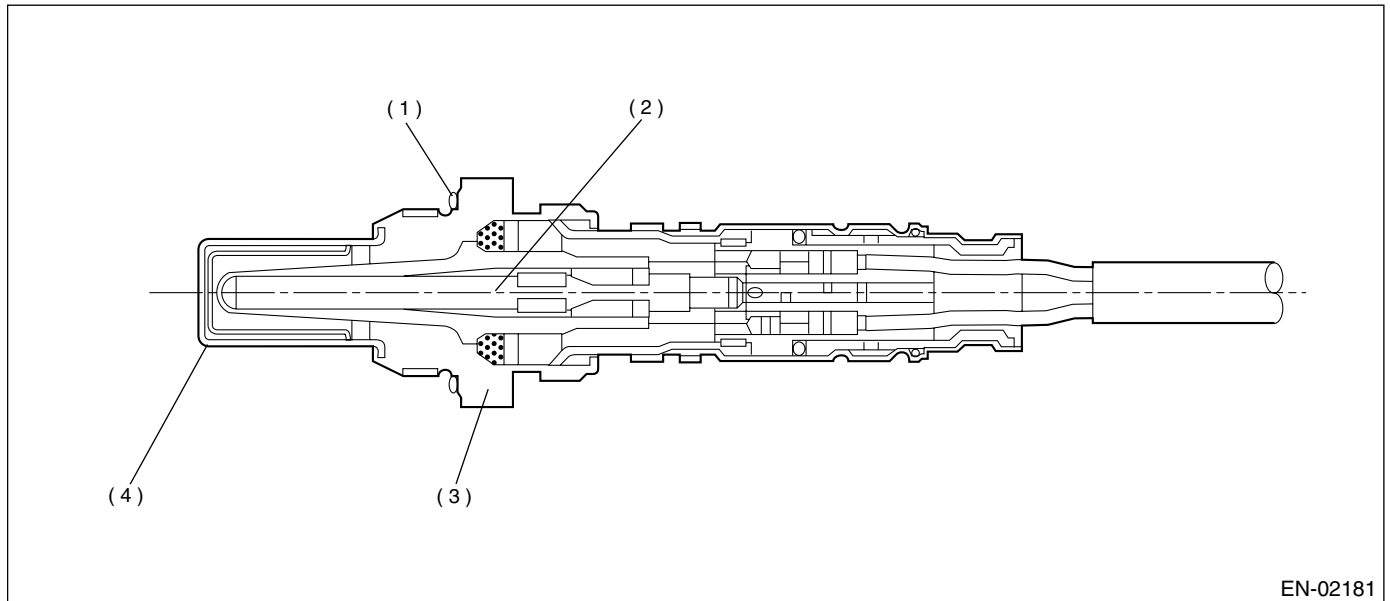

EN-02181

- (1) Gasket
- (2) Ceramic heater
- (3) Sensor housing
- (4) Protection tube

#### 3. ENABLE CONDITION

Secondary Parameters	Enable Conditions
After fuel shut off as follows	60 seconds or more
Battery voltage	> 10.9 V
Control duty $\geq$ 70%	20 seconds or more

#### 4. GENERAL DRIVING CYCLE

Perform diagnosis continuously in 30 seconds after starting engine.

# DIAGNOSTIC TROUBLE CODE (DTC) DETECTING CRITERIA

GENERAL DESCRIPTION

## 5. DIAGNOSTIC METHOD

Judge NG when the continuous time of completing the malfunction criteria below becomes more than the time needed for diagnosis (10 seconds). Judge OK and clear NG when the continuous time of not completing the malfunction criteria below becomes more than the time needed for diagnosis (10 seconds).

### Judgment Value

Malfunction Criteria	Threshold Value
Impedance of front oxygen (A/F) sensor	> 52 $\Omega$

**Time Needed for Diagnosis:** 10 seconds

**Malfunction Indicator Light Illumination:** Illuminates when malfunction occurs in 2 continuous driving cycles.

## 6. DTC CLEAR CONDITION

- When the OK idling cycle was completed 40 times in a row
- When "Clear Memory" was performed

## 7. MALFUNCTION INDICATOR LIGHT CLEAR CONDITION

- When the OK driving cycle was completed 3 times in a row
- When "Clear Memory" was performed

## 8. FAIL SAFE

- Front oxygen (A/F) sensor main learning correction: Not allowed to calculate
- Rear oxygen (A/F) sensor sub learning correction: Not allowed to calculate
- Correction when re-starting at high temperature: Normally minimum value 0.06 → 0
- Purge control: Not allowed to purge

## 9. ECM OPERATING AT DTC SETTING

Memorize the freeze frame data. (For test mode \$02)

# DIAGNOSTIC TROUBLE CODE (DTC) DETECTING CRITERIA

## GENERAL DESCRIPTION

### B: DTC P0031 — HO<sub>2</sub>S HEATER CONTROL CIRCUIT LOW (BANK 1 SENSOR 1)

#### 1. OUTLINE OF DIAGNOSIS

Detect the open or short circuit of front oxygen (A/F) sensor heater. Diagnosis is performed using front oxygen (A/F) sensor IC, and communication is established between front oxygen (A/F) sensor IC and main IC. Front oxygen (A/F) sensor IC judges NG when the data of voltage and current is abnormal with heater turned on or off.

#### 2. COMPONENT DESCRIPTION

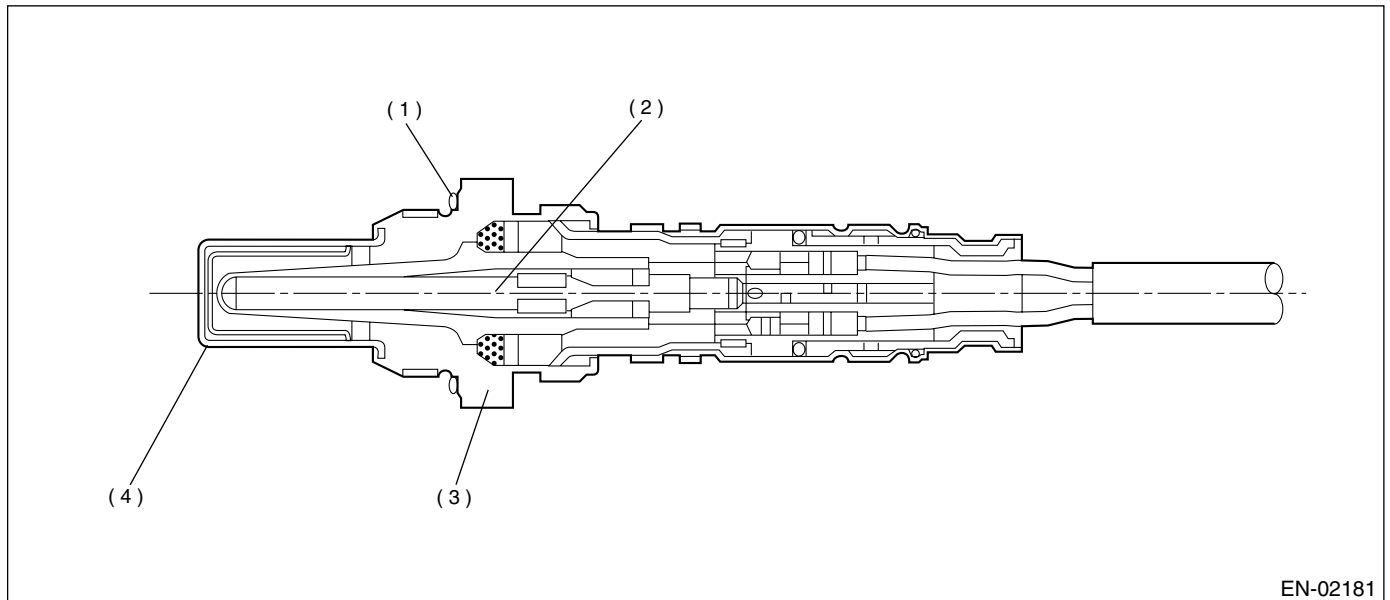

- (1) Gasket
- (2) Ceramic heater
- (3) Sensor housing
- (4) Protection tube

#### 3. ENABLE CONDITION

Secondary Parameters	Enable Conditions
None	

#### 4. GENERAL DRIVING CYCLE

Always perform diagnosis continuously.

# DIAGNOSTIC TROUBLE CODE (DTC) DETECTING CRITERIA

GENERAL DESCRIPTION

## 5. DIAGNOSTIC METHOD

Front oxygen (A/F) sensor IC judges NG when the continuous time of completing the malfunction criteria below becomes more than the time needed for diagnosis (4.5 seconds). Front oxygen (A/F) sensor IC judges OK and clear NG when the malfunction criteria below are not completed.

### Judgment Value

Malfunction Criteria	Threshold Value
Heater circuit	ON
• Voltage	< 5 V
• Current	< 1.5 A

**Time Needed for Diagnosis:** 4.5 seconds

**Malfunction Indicator Light Illumination:** Illuminates as soon as the malfunction occurs.

## 6. DTC CLEAR CONDITION

- When the OK idling cycle was completed 40 times in a row
- When "Clear Memory" was performed

## 7. MALFUNCTION INDICATOR LIGHT CLEAR CONDITION

- When the OK driving cycle was completed 3 times in a row
- When "Clear Memory" was performed

## 8. FAIL SAFE

- Front oxygen (A/F) sensor heater control: Not allowed to turn on heater
- Front oxygen (A/F) sensor main learning correction: Not allowed to calculate
- Rear oxygen (A/F) sensor sub learning correction: Not allowed to calculate
- Correction when re-starting at high temperature: Normally minimum value 0.06 → 0
- Purge control: Not allowed to purge

## 9. ECM OPERATING AT DTC SETTING

Memorize the freeze frame data. (For test mode \$02)

# DIAGNOSTIC TROUBLE CODE (DTC) DETECTING CRITERIA

## GENERAL DESCRIPTION

### C: DTC P0032 — HO2S HEATER CONTROL CIRCUIT HIGH (BANK 1 SENSOR 1) —

#### 1. OUTLINE OF DIAGNOSIS

Detect the open or short circuit of front oxygen (A/F) sensor heater. Diagnosis is performed using front oxygen (A/F) sensor IC, and communication is established between front oxygen (A/F) sensor IC and main IC. Front oxygen (A/F) sensor IC judges NG when the data of voltage and current is abnormal with heater turned on or off.

#### 2. COMPONENT DESCRIPTION

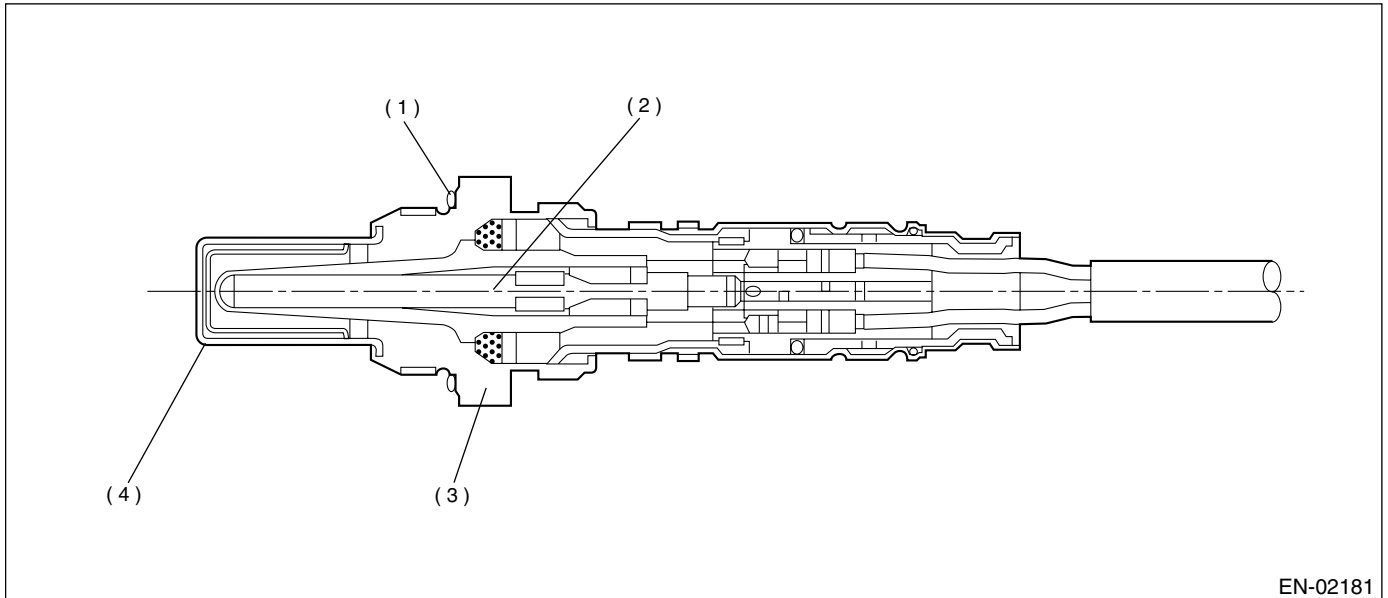

EN-02181

- (1) Gasket
- (2) Ceramic heater
- (3) Sensor housing
- (4) Protection tube

#### 3. ENABLE CONDITION

Secondary Parameters	Enable Conditions
None	

#### 4. GENERAL DRIVING CYCLE

Always perform diagnosis continuously.

#### 5. DIAGNOSTIC METHOD

Front oxygen (A/F) sensor IC judges NG when the continuous time until completing one of the malfunction criteria below becomes more than the time needed for diagnosis (4.5 seconds). Front oxygen (A/F) sensor IC judges OK and clear NG when any of the malfunction criteria below are not completed.

##### Judgment Value

Malfunction Criteria	Threshold Value
Heater circuit	OFF
• Voltage	> 5 V
• Current	> 1.5 A
• Heater current	≥ 23 A

**Time Needed for Diagnosis:** 4.5 seconds

**Malfunction Indicator Light Illumination:** Illuminates as soon as the malfunction occurs.

# DIAGNOSTIC TROUBLE CODE (DTC) DETECTING CRITERIA

GENERAL DESCRIPTION

---

## 6. DTC CLEAR CONDITION

- When the OK idling cycle was completed 40 times in a row
- When "Clear Memory" was performed

## 7. MALFUNCTION INDICATOR LIGHT CLEAR CONDITION

- When the OK driving cycle was completed 3 times in a row
- When "Clear Memory" was performed

## 8. FAIL SAFE

- Front oxygen (A/F) sensor heater control: Not allowed to turn on heater
- Front oxygen (A/F) sensor main learning correction: Not allowed to calculate
- Rear oxygen (A/F) sensor sub learning correction: Not allowed to calculate
- Correction when re-starting at high temperature: Normally minimum value 0.06 → 0
- Purge control: Not allowed to purge

## 9. ECM OPERATING AT DTC SETTING

Memorize the freeze frame data. (For test mode \$02)

# DIAGNOSTIC TROUBLE CODE (DTC) DETECTING CRITERIA

## GENERAL DESCRIPTION

### D: DTC P0037 — HO2S HEATER CONTROL CIRCUIT LOW (BANK 1 SENSOR 2)

#### 1. OUTLINE OF DIAGNOSIS

Detect open or short circuit of rear oxygen sensor heater. Rear oxygen sensor heater conducted the duty control, and the output terminal voltage at ON is 0 V and the output terminal voltage at OFF is the battery voltage. Judge NG when the terminal voltage remains Low.

#### 2. COMPONENT DESCRIPTION

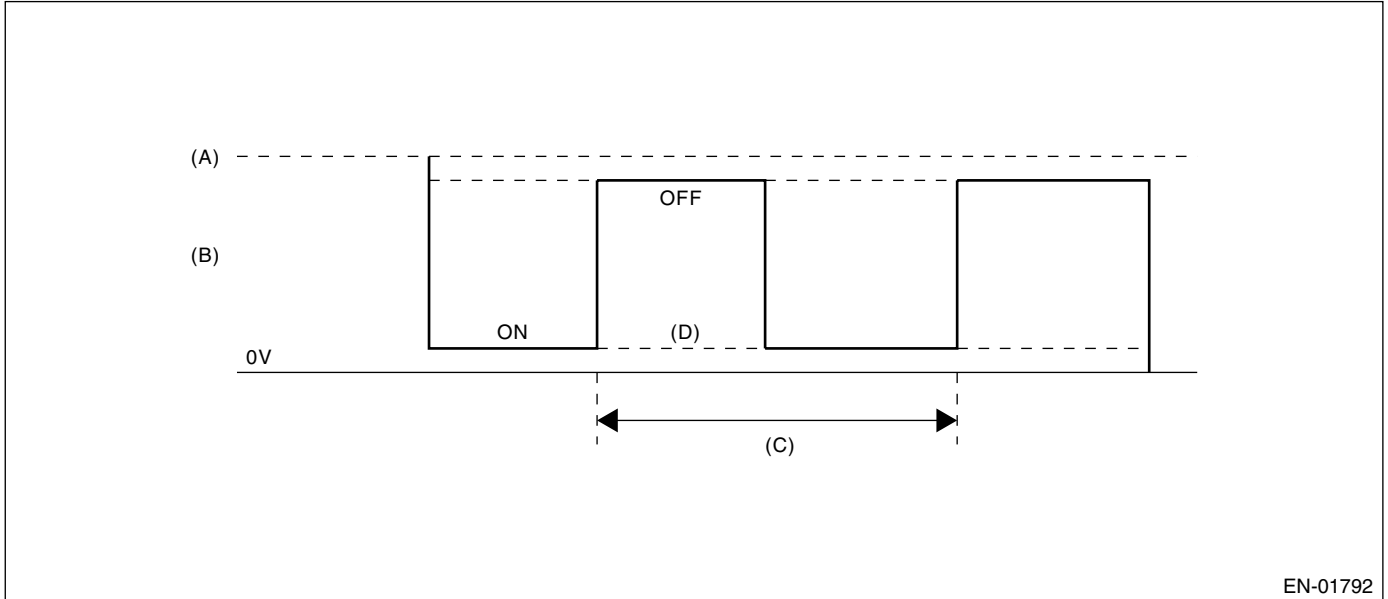

- (A) Battery voltage  
(B) Rear oxygen sensor heater output voltage  
(C) 262 milliseconds (cycles)  
(D) Low malfunction voltage

#### 3. ENABLE CONDITION

Secondary Parameters	Enable Conditions
Ignition switch	ON
Battery voltage	> 10.9 V
Duty ratio of heater output	19.9 ↔ 79.6%
Engine speed	< 4500 rpm

#### 4. GENERAL DRIVING CYCLE

Perform the diagnosis continuously after engine starting.

#### 5. DIAGNOSTIC METHOD

Judge NG when the continuous time of completing the malfunction criteria below becomes more than 5 seconds. Judge OK and clear the NG when the malfunction criteria below are not completed.

##### Judgment Value

Malfunction Criteria	Threshold Value
AD Max. value at heater OFF	< 10.12 V

**Time Needed for Diagnosis:** 5 seconds

**Malfunction Indicator Light Illumination:** Illuminates when malfunction occurs in 2 continuous driving cycles.



# DIAGNOSTIC TROUBLE CODE (DTC) DETECTING CRITERIA

GENERAL DESCRIPTION

---

## 6. DTC CLEAR CONDITION

- When the OK idling cycle was completed 40 times in a row
- When "Clear Memory" was performed

## 7. MALFUNCTION INDICATOR LIGHT CLEAR CONDITION

- When the OK driving cycle was completed 3 times in a row
- When "Clear Memory" was performed

## 8. FAIL SAFE

Sub feedback control: Not allowed

## 9. ECM OPERATING AT DTC SETTING

Memorize the freeze frame data. (For test mode \$02)

# DIAGNOSTIC TROUBLE CODE (DTC) DETECTING CRITERIA

## GENERAL DESCRIPTION

### E: DTC P0038 — HO2S HEATER CONTROL CIRCUIT HIGH (BANK 1 SENSOR 2) —

#### 1. OUTLINE OF DIAGNOSIS

Detect open or short circuit of rear oxygen heater. Rear oxygen heater conducted the duty control, and the output terminal voltage at ON is 0 V and the output terminal voltage at OFF is the battery voltage. Judge NG when the terminal voltage remains High.

#### 2. COMPONENT DESCRIPTION

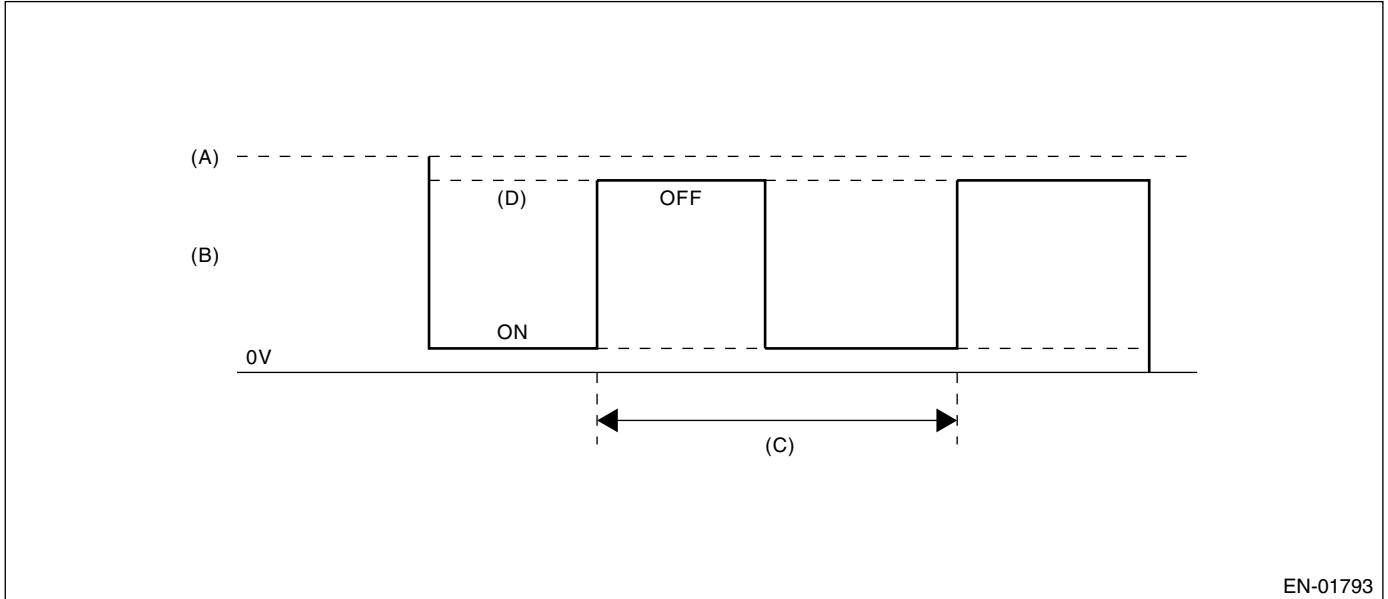

EN-01793

- (A) Battery voltage
- (B) Rear oxygen sensor heater output voltage
- (C) 262 milliseconds (cycles)
- (D) High malfunction voltage

#### 3. ENABLE CONDITION

Secondary Parameters	Enable Conditions
Ignition switch	ON
Battery voltage	> 10.9 V
Duty ratio of heater output	19.9 ↔ 79.6%
Engine speed	< 4500 rpm

#### 4. GENERAL DRIVING CYCLE

Perform the diagnosis continuously after engine starting.

#### 5. DIAGNOSTIC METHOD

Judge NG when the continuous time of completing the malfunction criteria below becomes more than 5 seconds. Judge OK and clear the NG when the malfunction criteria below are not completed.

##### Judgment Value

Malfunction Criteria	Threshold Value
AD Min. value at heater ON	> 1.92 V

**Time Needed for Diagnosis:** 5 seconds

**Malfunction Indicator Light Illumination:** Illuminates when malfunction occurs in 2 continuous driving cycles.

# DIAGNOSTIC TROUBLE CODE (DTC) DETECTING CRITERIA

GENERAL DESCRIPTION

---

## 6. DTC CLEAR CONDITION

- When the OK idling cycle was completed 40 times in a row
- When "Clear Memory" was performed

## 7. MALFUNCTION INDICATOR LIGHT CLEAR CONDITION

- When the OK driving cycle was completed 3 times in a row
- When "Clear Memory" was performed

## 8. FAIL SAFE

Sub feedback control: Not allowed

## 9. ECM OPERATING AT DTC SETTING

Memorize the freeze frame data. (For test mode \$02)

## DIAGNOSTIC TROUBLE CODE (DTC) DETECTING CRITERIA

### GENERAL DESCRIPTION

---

#### **F: DTC P0050 — HO2S HEATER CONTROL CIRCUIT (BANK 2 SENSOR 1) —**

NOTE:

For detecting criteria, refer to P0030. <Ref. to GD(H6DO)-10, DTC P0030 — HO2S HEATER CONTROL CIRCUIT (BANK 1 SENSOR 1) —, Diagnostic Trouble Code (DTC) Detecting Criteria.>

#### **G: DTC P0051 — HO2S HEATER CONTROL CIRCUIT LOW (BANK 2 SENSOR 1)**

NOTE:

For detecting criteria, refer to P0031. <Ref. to GD(H6DO)-12, DTC P0031 — HO2S HEATER CONTROL CIRCUIT LOW (BANK 1 SENSOR 1) —, Diagnostic Trouble Code (DTC) Detecting Criteria.>

#### **H: DTC P0052 — HO2S HEATER CONTROL CIRCUIT HIGH (BANK 2 SENSOR 1) —**

NOTE:

For detecting criteria, refer to P0032. <Ref. to GD(H6DO)-14, DTC P0032 — HO2S HEATER CONTROL CIRCUIT HIGH (BANK 1 SENSOR 1) —, Diagnostic Trouble Code (DTC) Detecting Criteria.>

# DIAGNOSTIC TROUBLE CODE (DTC) DETECTING CRITERIA

GENERAL DESCRIPTION

---

MEMO:

# DIAGNOSTIC TROUBLE CODE (DTC) DETECTING CRITERIA

## GENERAL DESCRIPTION

### I: DTC P0068 — MANIFOLD PRESSURE SENSOR RANGE/PERFORMANCE —

#### 1. OUTLINE OF DIAGNOSIS

Detect the malfunction of intake manifold pressure sensor output property. Judge NG when the intake air pressure AD value is Low whereas it seemed to be High from the viewpoint of engine condition, or when it is High whereas it seemed to be Low from the engine condition.

#### 2. COMPONENT DESCRIPTION

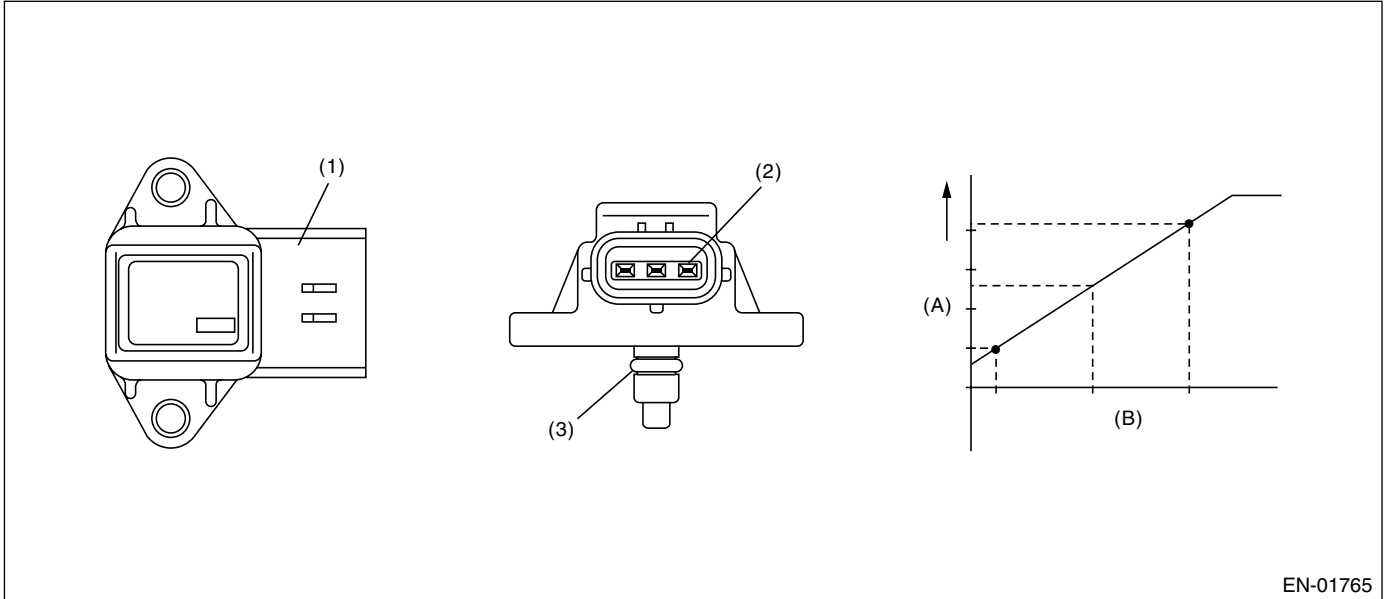

EN-01765

- (1) Connector
- (2) Terminal
- (3) O-ring

- (A) Output voltage
- (B) Absolute pressure

#### 3. ENABLE CONDITION

Secondary Parameters	Enable Conditions
Engine coolant temperature	$\geq 75^{\circ}\text{C}$ ( $167^{\circ}\text{F}$ )

#### 4. GENERAL DRIVING CYCLE

Perform the diagnosis continuously after idling.

# DIAGNOSTIC TROUBLE CODE (DTC) DETECTING CRITERIA

GENERAL DESCRIPTION

## 5. DIAGNOSTIC METHOD

### • Abnormality Judgment

Judge NG when either Low side or High side becomes NG. Judge NG when the continuous time of completing the malfunction criteria below becomes more than 3 seconds.

### • Judgment Value

Malfunction Criteria	Threshold Value
Low side	
Engine speed	< 2500 rpm
Throttle position	≥ 10°
Output voltage	< 1.3 V
High side	
Engine speed	600 ←→ 900 rpm
Throttle position	< 1.3°
Output voltage	≥ 2.6 V

**Time Needed for Diagnosis:** 3 seconds

**Malfunction Indicator Light Illumination:** Illuminates when malfunction occurs in 2 continuous driving cycles.

### • Normality Judgment

Judge OK and clear the NG when both Low side and High side become OK. Judge OK when the malfunction criteria below are completed.

### • Judgment Value

Malfunction Criteria	Threshold Value
Low side	
Engine speed	< 2500 rpm
Throttle position	≥ 10°
Output voltage	≥ 1.3 V
High side	
Engine speed	600 ←→ 900 rpm
Throttle position	< 1.3°
Output voltage	< 2.6 V

## 6. DTC CLEAR CONDITION

- When the OK idling cycle was completed 40 times in a row
- When "Clear Memory" was performed

## 7. MALFUNCTION INDICATOR LIGHT CLEAR CONDITION

- When the OK driving cycle was completed 3 times in a row
- When "Clear Memory" was performed

# DIAGNOSTIC TROUBLE CODE (DTC) DETECTING CRITERIA

## GENERAL DESCRIPTION

---

### 8. FAIL SAFE

- Intake manifold pressure sensor process: Estimate the pressure from engine speed and throttle position. When also throttle position is NG, adopt 66.7 kPa (500 mmHg, 19.69 inHg) as definite value.
- Heavy fuel judgment: Not allowed to carry out the heavy judgment.
- Fuel cut control: Fuel cut will operate at engine high speed.
- EVAP density learning (Fuel): Not allowed to learn
- Knocking compensation

At normal condition: Self-learning ignition advance value = knock F/B advance + overall self-learning advance value + partial self-learning advance value

When malfunctioning: Self-learning ignition advance value =  $-6^{\circ}\text{CA}$  ( $6^{\circ}\text{CA}$  retard)

knock F/B advance value =  $0^{\circ}\text{CA}$

Prohibit overall self-learning

Partially prohibit self-learning

- ISC control: Not allowed to calculate the amount of ISC feedback.  
Amount of ISC open-loop compensation = Fixed at 6.82%
- Purge control: Not allowed to purge

### 9. ECM OPERATING AT DTC SETTING

Memorize the freeze frame data. (For test mode \$02)



# DIAGNOSTIC TROUBLE CODE (DTC) DETECTING CRITERIA

GENERAL DESCRIPTION

---

MEMO:

# DIAGNOSTIC TROUBLE CODE (DTC) DETECTING CRITERIA

## GENERAL DESCRIPTION

### J: DTC P0107 — MANIFOLD ABSOLUTE PRESSURE/BAROMETRIC PRESSURE CIRCUIT LOW INPUT —

#### 1. OUTLINE OF DIAGNOSIS

Detect the open or short circuit of intake manifold pressure sensor. Judge NG when out of the standard value.

#### 2. COMPONENT DESCRIPTION

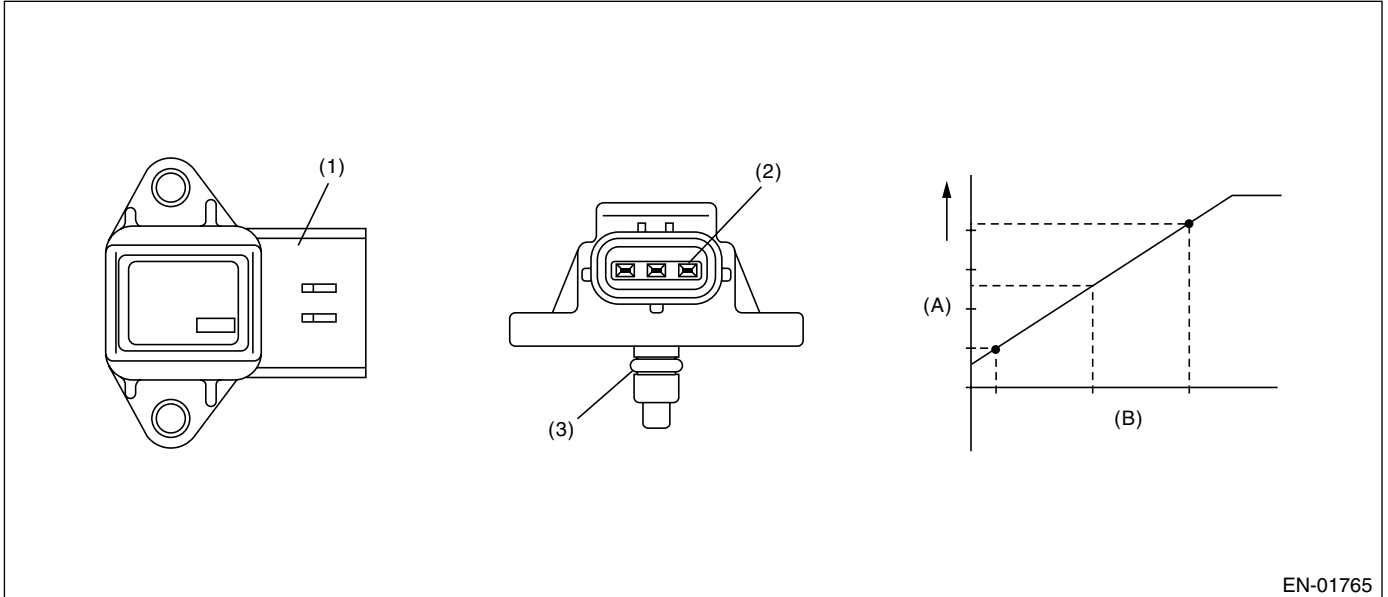

EN-01765

- (1) Connector
- (2) Terminal
- (3) O-ring
- (A) Output voltage
- (B) Absolute pressure

#### 3. ENABLE CONDITION

Secondary Parameters	Enable Conditions
None	

#### 4. GENERAL DRIVING CYCLE

Always perform the diagnosis continuously.

#### 5. DIAGNOSTIC METHOD

Judge NG when the continuous time of completing the malfunction criteria below becomes more than 0.5 seconds. Judge OK and clear the NG when the malfunction criteria below are not completed.

##### Judgment Value

Malfunction Criteria	Threshold Value
Output voltage	< 0.65 V

**Time Needed for Diagnosis:** 0.5 seconds

**Malfunction Indicator Light Illumination:** Illuminates as soon as the malfunction occurs.

#### 6. DTC CLEAR CONDITION

- When the OK idling cycle was completed 40 times in a row
- When "Clear Memory" was performed

# DIAGNOSTIC TROUBLE CODE (DTC) DETECTING CRITERIA

GENERAL DESCRIPTION

## 7. MALFUNCTION INDICATOR LIGHT CLEAR CONDITION

- When the OK driving cycle was completed 3 times in a row
- When "Clear Memory" was performed

## 8. FAIL SAFE

- Intake manifold pressure sensor process: Estimate the pressure from engine speed and throttle position. When also throttle position is NG, adopt 66.7 kPa (500 mmHg, 19.69 inHg) as definite value.
- Heavy fuel judgment: Not allowed to carry out the heavy judgment.
- Fuel cut control: Fuel cut will operate at engine high speed.
- EVAP density learning (Fuel): Not allowed to learn
- Knocking compensation

At normal condition: Self-learning ignition advance value = knock F/B advance + overall self-learning advance value + partial self-learning advance value

When malfunctioning: Self-learning ignition advance value =  $-6^{\circ}\text{CA}$  ( $6^{\circ}\text{CA}$  retard)

knock F/B advance value =  $0^{\circ}\text{CA}$

Prohibit overall self-learning

Partially prohibit self-learning

- ISC control: Not allowed to calculate the amount of ISC feedback.

Amount of ISC open-loop compensation = Fixed at 6.82%

- Purge control: Not allowed to purge

## 9. ECM OPERATING AT DTC SETTING

Memorize the freeze frame data. (For test mode \$02)

# DIAGNOSTIC TROUBLE CODE (DTC) DETECTING CRITERIA

## GENERAL DESCRIPTION

### K: DTC P0108 — MANIFOLD ABSOLUTE PRESSURE/BAROMETRIC PRESSURE CIRCUIT HIGH INPUT —

#### 1. OUTLINE OF DIAGNOSIS

Detect the open or short circuit of intake manifold pressure sensor. Judge NG when out of the standard value.

#### 2. COMPONENT DESCRIPTION

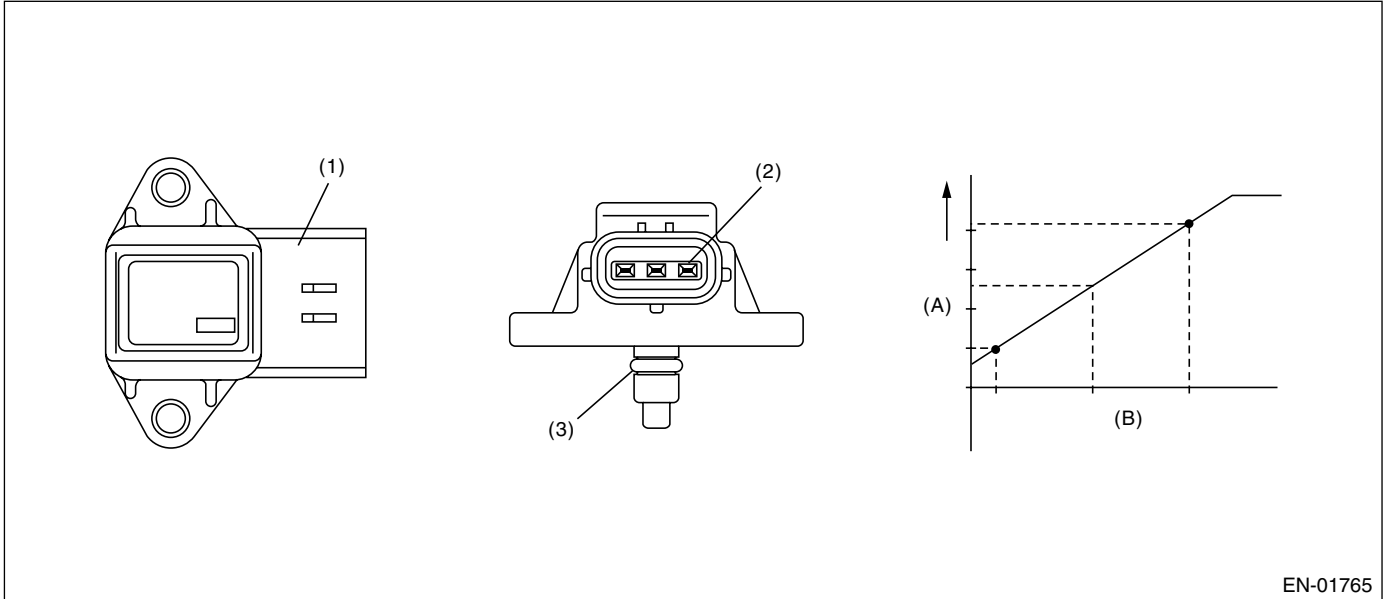

EN-01765

- (1) Connector
- (2) Terminal
- (3) O-ring

- (A) Output voltage
- (B) Absolute pressure

#### 3. ENABLE CONDITION

Secondary Parameters	Enable Conditions
None	

#### 4. GENERAL DRIVING CYCLE

Always perform the diagnosis continuously.

#### 5. DIAGNOSTIC METHOD

Judge NG when the continuous time of completing the malfunction criteria below becomes more than 0.5 seconds. Judge OK and clear the NG when the malfunction criteria below are not completed.

##### Judgment Value

Malfunction Criteria	Threshold Value
Output voltage	$\geq 4.5 \text{ V}$

**Time Needed for Diagnosis:** 0.5 seconds

**Malfunction Indicator Light Illumination:** Illuminates as soon as the malfunction occurs.

#### 6. DTC CLEAR CONDITION

- When the OK idling cycle was completed 40 times in a row
- When "Clear Memory" was performed

# DIAGNOSTIC TROUBLE CODE (DTC) DETECTING CRITERIA

GENERAL DESCRIPTION

## 7. MALFUNCTION INDICATOR LIGHT CLEAR CONDITION

- When the OK driving cycle was completed 3 times in a row
- When "Clear Memory" was performed

## 8. FAIL SAFE

- Intake manifold pressure sensor process: Estimate the pressure from engine speed and throttle position. When also throttle position is NG, adopt 66.7 kPa (500 mmHg, 19.69 inHg) as definite value.
- Heavy fuel judgment: Not allowed to carry out the heavy judgment.
- Fuel cut control: Fuel cut will operate at engine high speed.
- EVAP density learning (Fuel): Not allowed to learn
- Knocking compensation

At normal condition: Self-learning ignition advance value = knock F/B advance + overall self-learning advance value + partial self-learning advance value

When malfunctioning: Self-learning ignition advance value =  $-6^{\circ}\text{CA}$  ( $6^{\circ}\text{CA}$  retard)

knock F/B advance value =  $0^{\circ}\text{CA}$

Prohibit overall self-learning

Partially prohibit self-learning

- ISC control: Not allowed to calculate the amount of ISC feedback.

Amount of ISC open-loop compensation = Fixed at 6.82%

- Purge control: Not allowed to purge

## 9. ECM OPERATING AT DTC SETTING

Memorize the freeze frame data. (For test mode \$02)

# DIAGNOSTIC TROUBLE CODE (DTC) DETECTING CRITERIA

## GENERAL DESCRIPTION

### L: DTC P0111 — INTAKE AIR TEMPERATURE CIRCUIT RANGE/PERFORMANCE —

#### 1. OUTLINE OF DIAGNOSIS

Detect the malfunction of intake air temperature sensor output property. Judge NG when the intake air temperature is not varied whereas it seemed to be varied from the viewpoint of engine condition.

#### 2. COMPONENT DESCRIPTION

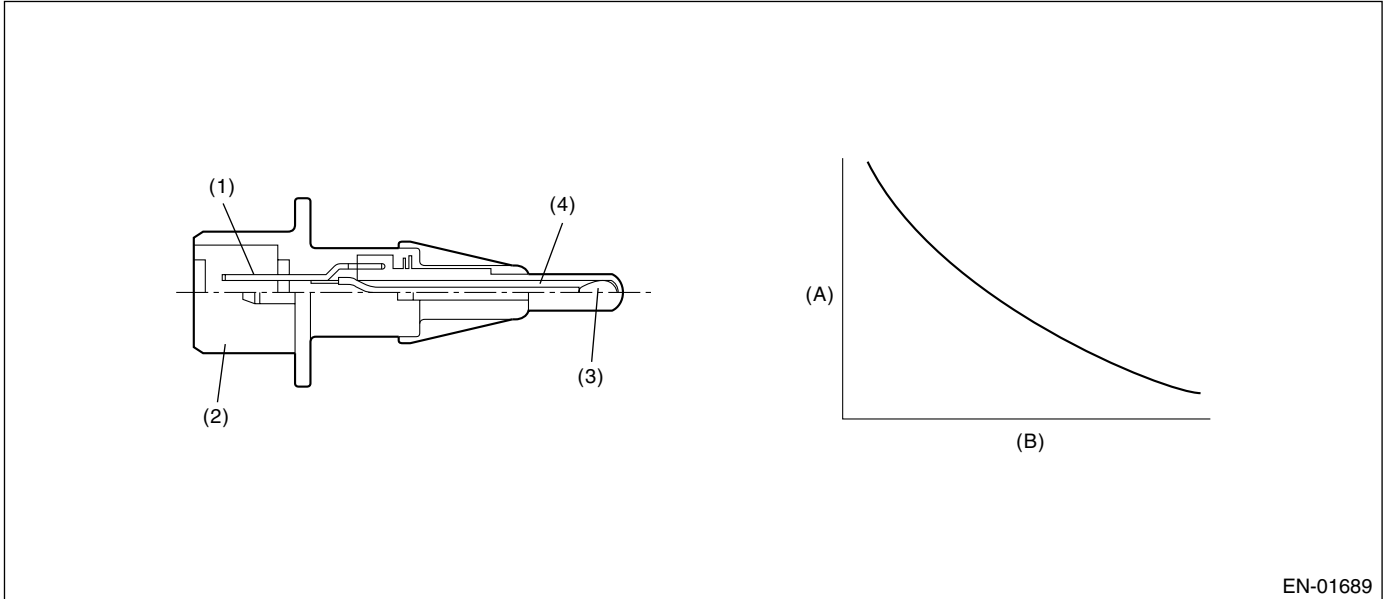

EN-01689

- (1) Terminal
- (2) Connector

- (3) Thermistor
- (4) Housing

- (A) Resistance ( $\Omega$ )
- (B) Intake air temperature  $^{\circ}\text{C}$  ( $^{\circ}\text{F}$ )

#### 3. ENABLE CONDITION

Secondary Parameters	Enable Conditions
Coolant temp. before engine start	$< 30^{\circ}\text{C}$ ( $86^{\circ}\text{F}$ )
Coolant temperature	$> 75^{\circ}\text{C}$ ( $167^{\circ}\text{F}$ )
Battery voltage	$\geq 10.9\text{ V}$
Continuous time when the vehicle speed is less than 50 km/h (31 MPH)	600 seconds or more

#### 4. GENERAL DRIVING CYCLE

Perform the diagnosis when the vehicle speed condition is completed after idling from starting the cooled engine.

# DIAGNOSTIC TROUBLE CODE (DTC) DETECTING CRITERIA

GENERAL DESCRIPTION

## 5. DIAGNOSTIC METHOD

Judge NG when the judgment value is within the range of the malfunction criteria below. Judge OK when it is not within the specified range.

### Judgment Value

Malfunction Criteria	Threshold Value
Output voltage difference between Max. and Min.	< 20 mV (It is equal to approx. 0.5°C (0.9°F) around 25°C (77°F).)

**Time Needed for Diagnosis:** 1 second

**Malfunction Indicator Light Illumination:** Illuminates when malfunction occurs in 2 continuous driving cycles.

## 6. DTC CLEAR CONDITION

- When the OK idling cycle was completed 40 times in a row
- When "Clear Memory" was performed

## 7. MALFUNCTION INDICATOR LIGHT CLEAR CONDITION

- When the OK driving cycle was completed 3 times in a row
- When "Clear Memory" was performed

## 8. FAIL SAFE

Intake air temperature sensor process: Intake air temperature is fixed at 20°C (68°F).

## 9. ECM OPERATING AT DTC SETTING

Memorize the freeze frame data. (For test mode \$02)

# DIAGNOSTIC TROUBLE CODE (DTC) DETECTING CRITERIA

## GENERAL DESCRIPTION

### M: DTC P0112 — INTAKE AIR TEMPERATURE CIRCUIT LOW INPUT —

#### 1. OUTLINE OF DIAGNOSIS

Detect the open or short circuit of intake air temperature sensor. Judge NG when out of the standard value.

#### 2. COMPONENT DESCRIPTION

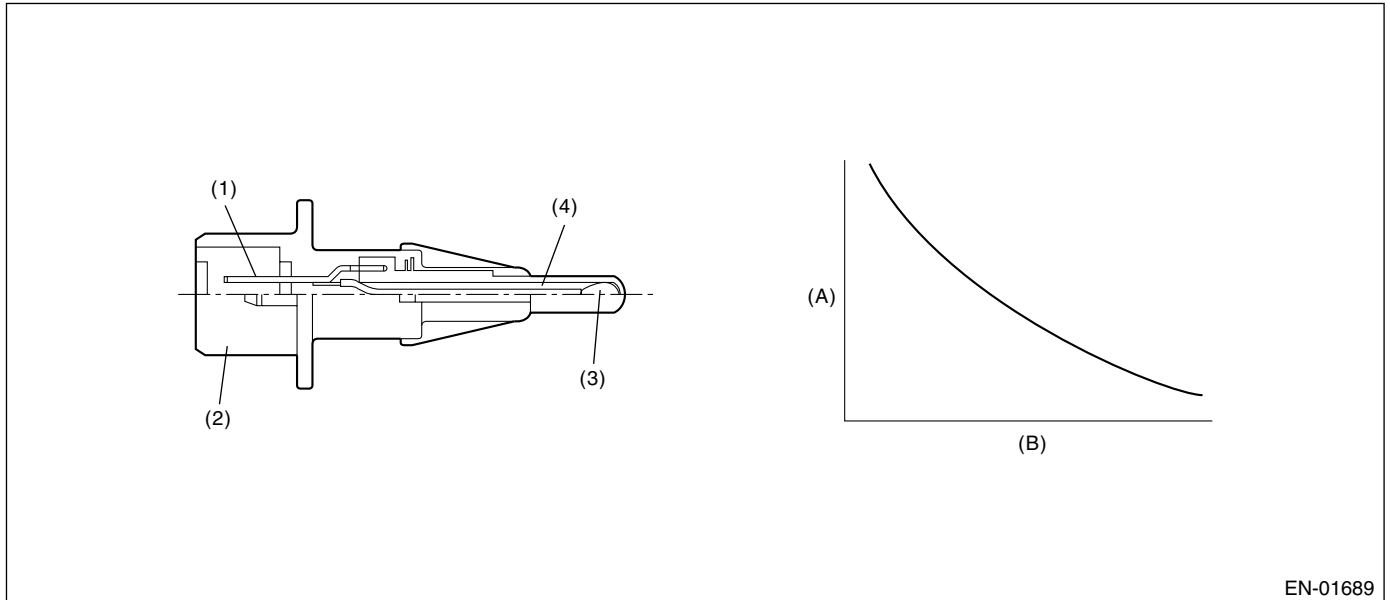

(1) Terminal  
(2) Connector

(3) Thermistor  
(4) Housing

(A) Resistance ( $\Omega$ )  
(B) Intake air temperature  $^{\circ}\text{C}$  ( $^{\circ}\text{F}$ )

#### 3. ENABLE CONDITION

Secondary Parameters	Enable Conditions
None	

#### 4. GENERAL DRIVING CYCLE

Always perform the diagnosis continuously.



# DIAGNOSTIC TROUBLE CODE (DTC) DETECTING CRITERIA

GENERAL DESCRIPTION

## 5. DIAGNOSTIC METHOD

### • Abnormality Judgment

Judge NG when the continuous time of completing the malfunction criteria below becomes more than 0.5 seconds.

### • Judgment Value

Malfunction Criteria	Threshold Value
Output voltage	< 0.23 V
Ignition switch	ON

**Time Needed for Diagnosis:** 0.5 seconds

**Malfunction Indicator Light Illumination:** Illuminates as soon as the malfunction occurs.

### • Normality Judgment

Judge OK and clear the NG when the malfunction criteria below are completed.

### • Judgment Value

Malfunction Criteria	Threshold Value
Output voltage	$\geq 0.23$ V
Ignition switch	ON

## 6. DTC CLEAR CONDITION

- When the OK idling cycle was completed 40 times in a row
- When "Clear Memory" was performed

## 7. MALFUNCTION INDICATOR LIGHT CLEAR CONDITION

- When the OK driving cycle was completed 3 times in a row
- When "Clear Memory" was performed

## 8. FAIL SAFE

Intake air temperature sensor process: Intake air temperature is fixed at 20°C (68°F).

## 9. ECM OPERATING AT DTC SETTING

Memorize the freeze frame data. (For test mode \$02)

# DIAGNOSTIC TROUBLE CODE (DTC) DETECTING CRITERIA

## GENERAL DESCRIPTION

### N: DTC P0113 — INTAKE AIR TEMPERATURE CIRCUIT HIGH INPUT —

#### 1. OUTLINE OF DIAGNOSIS

Detect the open or short circuit of intake air temperature sensor. Judge NG when out of the standard value.

#### 2. COMPONENT DESCRIPTION

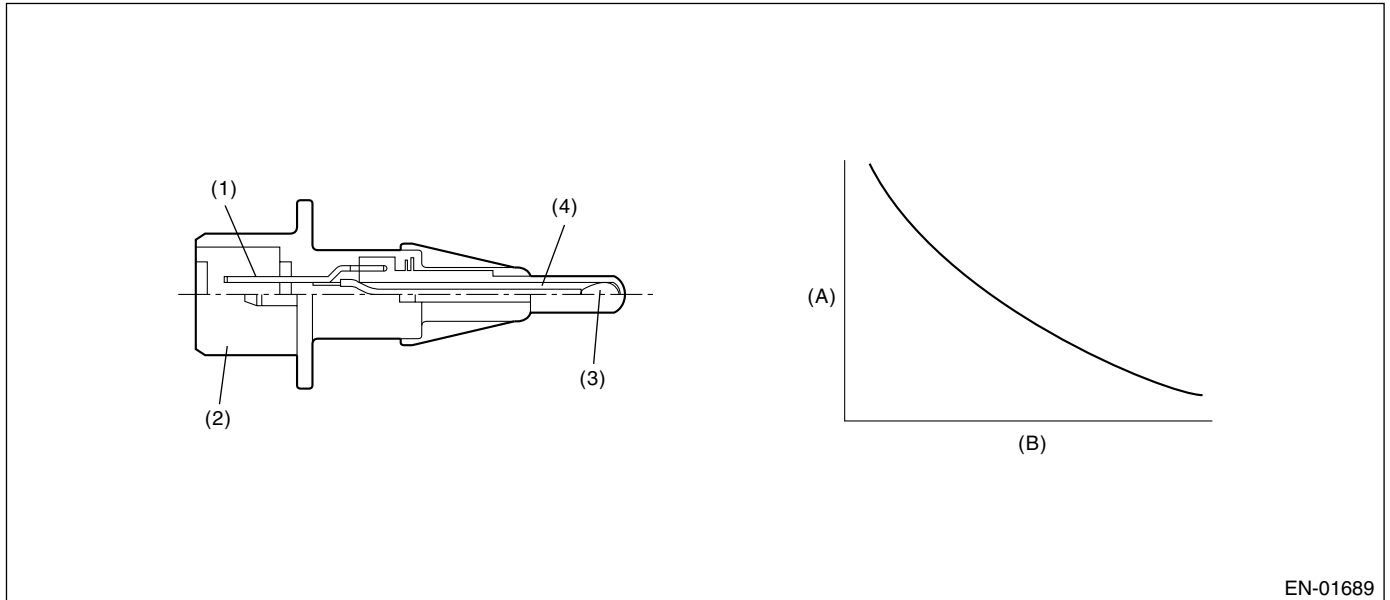

EN-01689

(1) Terminal  
(2) Connector

(3) Thermistor  
(4) Housing

(A) Resistance ( $\Omega$ )  
(B) Intake air temperature °C (°F)

#### 3. ENABLE CONDITION

Secondary Parameters	Enable Conditions
None	

#### 4. GENERAL DRIVING CYCLE

Always perform the diagnosis continuously.

# DIAGNOSTIC TROUBLE CODE (DTC) DETECTING CRITERIA

GENERAL DESCRIPTION

## 5. DIAGNOSTIC METHOD

### • Abnormality Judgment

Judge NG when the continuous time of completing the malfunction criteria below becomes more than 0.5 seconds.

### • Judgment Value

Malfunction Criteria	Threshold Value
Output voltage	$\geq 4.72$ V
Ignition switch	ON

**Time Needed for Diagnosis:** 0.5 seconds

**Malfunction Indicator Light Illumination:** Illuminates as soon as the malfunction occurs.

### • Normality Judgment

Judge OK and clear the NG when the malfunction criteria below are completed.

### • Judgment Value

Malfunction Criteria	Threshold Value
Output voltage	$< 4.72$ V
Ignition switch	ON

## 6. DTC CLEAR CONDITION

- When the OK idling cycle was completed 40 times in a row
- When "Clear Memory" was performed

## 7. MALFUNCTION INDICATOR LIGHT CLEAR CONDITION

- When the OK driving cycle was completed 3 times in a row
- When "Clear Memory" was performed

## 8. FAIL SAFE

Intake air temperature sensor process: Intake air temperature is fixed at 20°C (68°F).

## 9. ECM OPERATING AT DTC SETTING

Memorize the freeze frame data. (For test mode \$02)

# DIAGNOSTIC TROUBLE CODE (DTC) DETECTING CRITERIA

## GENERAL DESCRIPTION

### O: DTC P0117 — ENGINE COOLANT TEMPERATURE CIRCUIT LOW INPUT —

#### 1. OUTLINE OF DIAGNOSIS

Detect the open or short circuit of engine coolant temperature sensor. Judge NG when out of the standard value.

#### 2. COMPONENT DESCRIPTION

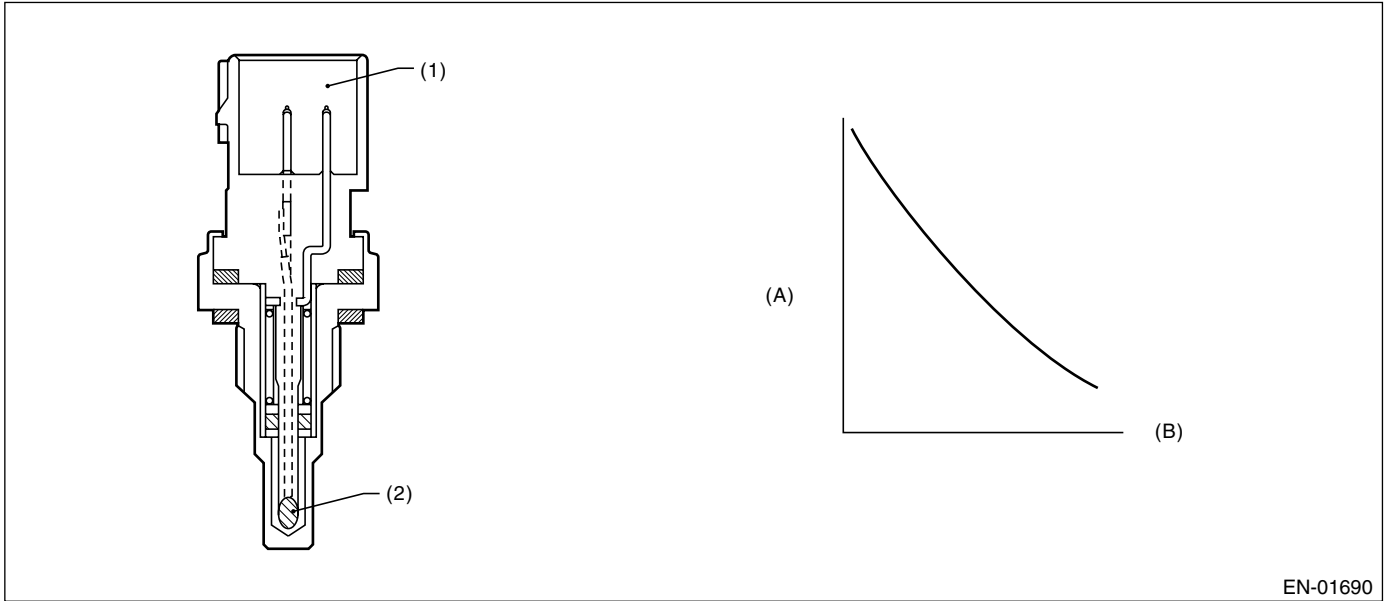

EN-01690

(1) Connector

(2) Thermistor element

(A) Resistance (k $\Omega$ )

(B) Temperature °C (°F)

#### 3. ENABLE CONDITION

Secondary Parameters	Enable Conditions
None	

#### 4. GENERAL DRIVING CYCLE

Always perform the diagnosis continuously.

#### 5. DIAGNOSTIC METHOD

Judge NG when the continuous time of completing the malfunction criteria below becomes more than 0.5 seconds. Judge OK and clear the NG when the malfunction criteria below are not completed.

##### Judgment Value

Malfunction Criteria	Threshold Value
Output voltage	< 0.23 V

**Time Needed for Diagnosis:** 0.5 seconds

**Malfunction Indicator Light Illumination:** Illuminates as soon as the malfunction occurs.

#### 6. DTC CLEAR CONDITION

- When the OK idling cycle was completed 40 times in a row
- When "Clear Memory" was performed

#### 7. MALFUNCTION INDICATOR LIGHT CLEAR CONDITION

- When the OK driving cycle was completed 3 times in a row
- When "Clear Memory" was performed

# DIAGNOSTIC TROUBLE CODE (DTC) DETECTING CRITERIA

GENERAL DESCRIPTION

---

## 8. FAIL SAFE

- Engine coolant temperature process: Fix the engine coolant temperature at 70°C (158°F).
- ISC feedback: Calculate the target engine speed setting the engine coolant temperature to 70°C (158°F).
- ISC learning: Not allowed to learn.
- Heavy fuel judgment control: Not allowed to carry out the heavy judgment.
- Air conditioner control: Not allowed to turn the air conditioner to ON.
- Radiator fan control: Both main and sub fan are in High driving.
- Increase compensation coefficient at a high water temperature: The water temperature condition is disregarded and increased by approval of other condition, though usually increases by a high water temperature and approval of other condition.

## 9. ECM OPERATING AT DTC SETTING

Memorize the freeze frame data. (For test mode \$02)

# DIAGNOSTIC TROUBLE CODE (DTC) DETECTING CRITERIA

## GENERAL DESCRIPTION

### P: DTC P0118 — ENGINE COOLANT TEMPERATURE CIRCUIT HIGH INPUT —

#### 1. OUTLINE OF DIAGNOSIS

Detect the open or short circuit of engine coolant temperature sensor. Judge NG when out of the standard value.

#### 2. COMPONENT DESCRIPTION

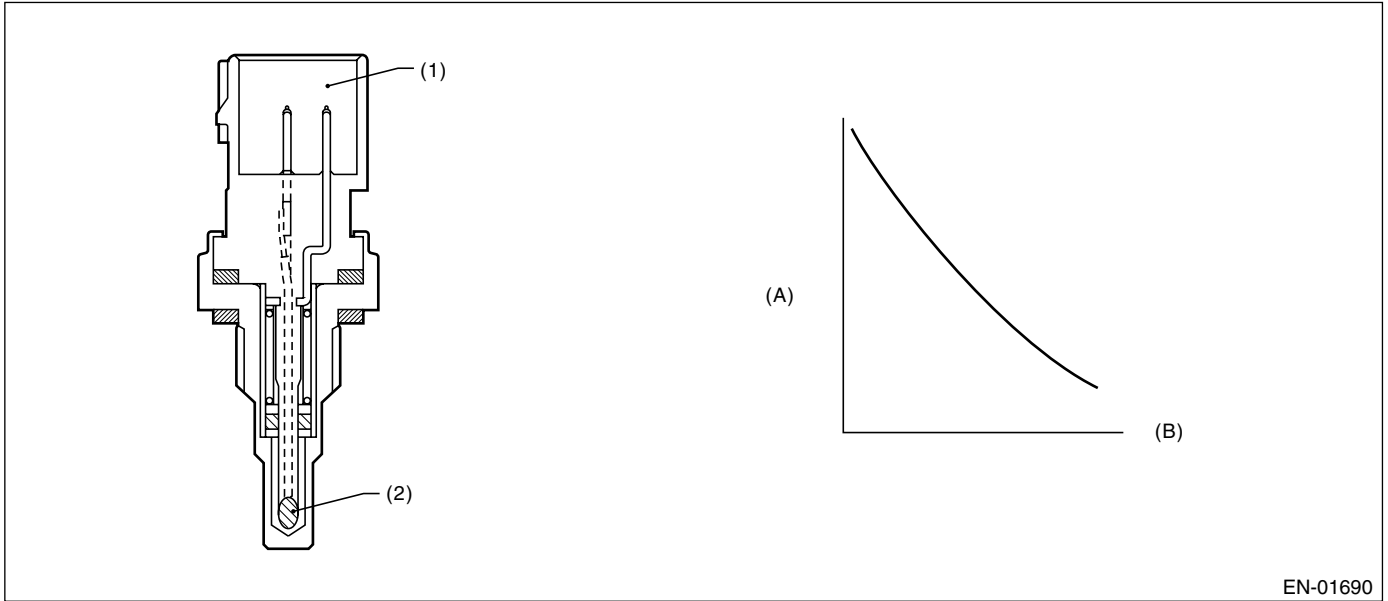

EN-01690

(1) Connector

(2) Thermistor element

(A) Resistance (k $\Omega$ )

(B) Temperature °C (°F)

#### 3. ENABLE CONDITION

Secondary Parameters	Enable Conditions
None	

#### 4. GENERAL DRIVING CYCLE

Always perform the diagnosis continuously.

#### 5. DIAGNOSTIC METHOD

Judge NG when the continuous time of completing the malfunction criteria below becomes more than 0.5 seconds. Judge OK and clear the NG when the malfunction criteria below are not completed.

##### Judgment Value

Malfunction Criteria	Threshold Value
Output voltage	$\geq 4.72$ V

**Time Needed for Diagnosis:** 0.5 seconds

**Malfunction Indicator Light Illumination:** Illuminates as soon as the malfunction occurs.

#### 6. DTC CLEAR CONDITION

- When the OK idling cycle was completed 40 times in a row
- When "Clear Memory" was performed

#### 7. MALFUNCTION INDICATOR LIGHT CLEAR CONDITION

- When the OK driving cycle was completed 3 times in a row
- When "Clear Memory" was performed

# DIAGNOSTIC TROUBLE CODE (DTC) DETECTING CRITERIA

GENERAL DESCRIPTION

---

## 8. FAIL SAFE

- Engine coolant temperature process: Fix the engine coolant temperature at 70°C (158°F).
- ISC feedback: Calculate the target engine speed setting the engine coolant temperature to 70°C (158°F).
- ISC learning: Not allowed to learn.
- Heavy fuel judgment control: Not allowed to carry out the heavy judgment.
- Air conditioner control: Not allowed to turn the air conditioner to ON.
- Radiator fan control: Both main and sub fan are in High driving.
- Increase compensation coefficient at a high water temperature: The water temperature condition is disregarded and increased by approval of other condition, though usually increases by a high water temperature and approval of other condition.

## 9. ECM OPERATING AT DTC SETTING

Memorize the freeze frame data. (For test mode \$02)

# DIAGNOSTIC TROUBLE CODE (DTC) DETECTING CRITERIA

## GENERAL DESCRIPTION

### Q: DTC P0121 — THROTTLE/PEDAL POSITION SENSOR/SWITCH “A” CIRCUIT RANGE/PERFORMANCE —

#### 1. OUTLINE OF DIAGNOSIS

Detect the malfunction of throttle position sensor output property. Judge NG when the throttle opening is largely different from the estimated value of throttle opening.

#### 2. COMPONENT DESCRIPTION

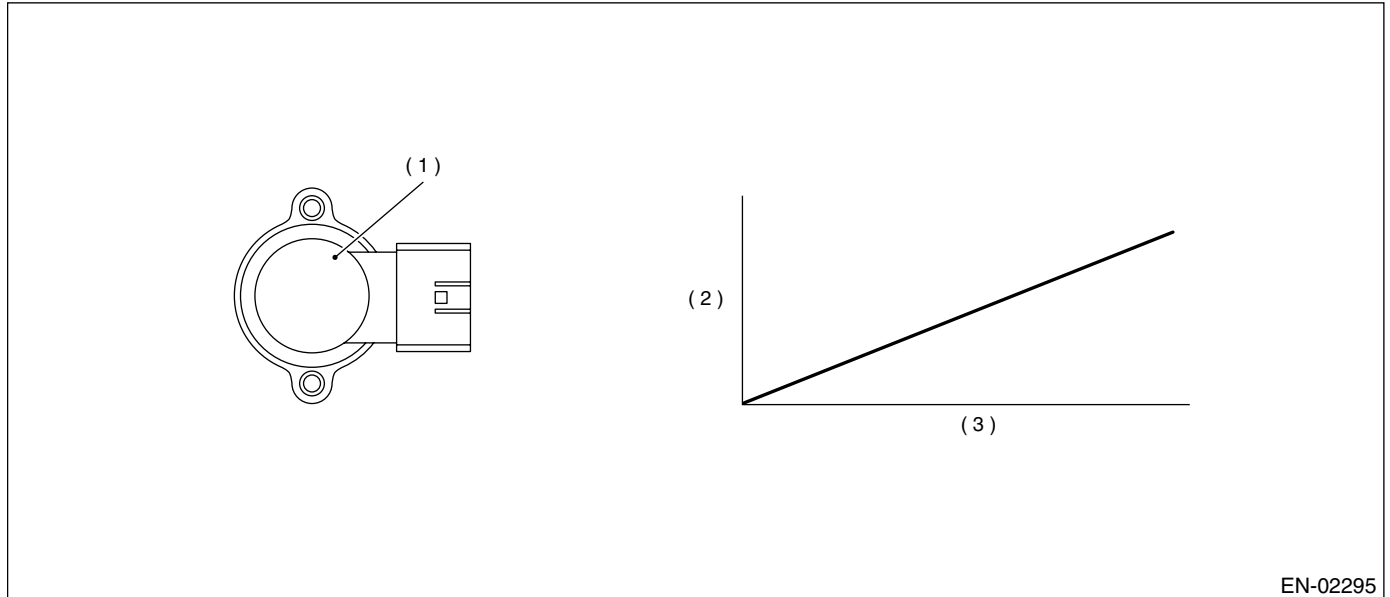

EN-02295

(1) Throttle position sensor

(2) Voltage (V)

(3) Throttle valve opening angle (°)

#### 3. ENABLE CONDITION

Secondary Parameters	Enable Conditions
Engine coolant temperature	> 71°C (160°F)
Intake air temperature	> -10°C (14°F)
Atmospheric pressure	≥ 75.1 kPa (563 mmHg, 22.2 inHg)
Battery voltage	> 10.9 V
Fuel level	≥ 9.6 ℓ (2-1/2 US gal, 2-1/8 Imp gal)

#### 4. GENERAL DRIVING CYCLE

Perform the diagnosis continuously after idling.



# DIAGNOSTIC TROUBLE CODE (DTC) DETECTING CRITERIA

GENERAL DESCRIPTION

## 5. DIAGNOSTIC METHOD

### • Abnormality Judgment

Judge NG when one of the malfunctions below is completed such as Low malfunction (1), Low malfunction (2) and High malfunction.

### • Judgment Value

Malfunction Criteria	Threshold Value
Low malfunction (1): Judge NG when the continuous time of completing the malfunction criteria below becomes more than 10 seconds. (Estimated value of throttle opening — output) throttle angle Engine speed Change of manifold absolute pressure during 0.5 engine revs. Manifold absolute pressure	$\geq 20.01^\circ$ 1600 $\longleftrightarrow$ 3500 rpm $< 1.30$ kPa (9.76 mmHg, 0.384 inHg) 201.5 $\longleftrightarrow$ Atmospheric pressure $-10.4$ kPa ( $-78$ mmHg, $-3.07$ inHg)
Low malfunction (2): Judge NG when the continuous time of completing the malfunction criteria below becomes more than 0.5 seconds $\times$ 3 times. Engine speed Intake manifold pressure Throttle opening Elapsed time after engine starting EGR monitor Closed throttle position learning	$\geq 500$ rpm $\geq 66.7$ kPa (500 mmHg, 19.69 inHg) $< 2^\circ$ $\geq 5$ seconds Not in operation Complete
High malfunction: Judge NG when the continuous time of completing the malfunction criteria below becomes more than 10 seconds. (estimated value of throttle opening — Output) throttle angle Engine speed Change of manifold absolute pressure during 0.5 engine revs. Manifold absolute pressure	$\geq 20.01^\circ$ 1600 $\longleftrightarrow$ 3500 rpm $< 1.30$ kPa (9.76 mmHg, 0.384 inHg) 201.5 $\longleftrightarrow$ Atmospheric pressure $-10.4$ kPa ( $-78$ mmHg, $-3.07$ inHg)

Estimated value of throttle opening: It is supposed from engine speed and intake manifold relative pressure.

### Time Needed for Diagnosis:

Low malfunction (1), 10 seconds

High malfunction

Low malfunction (2) 0.5 seconds  $\times$  3 times.

**Malfunction Indicator Light Illumination:** Illuminates when malfunction occurs in 2 continuous driving cycles.

### • Normality Judgment

Judge OK and clear the NG when all of the malfunctions below are not completed such as Low malfunction (1), Low malfunction (2) and High malfunction.

# DIAGNOSTIC TROUBLE CODE (DTC) DETECTING CRITERIA

## GENERAL DESCRIPTION

### • Judgment Value

Malfunction Criteria	Threshold Value
Low malfunction (1): Judge OK when the continuous time of completing the malfunction criteria below becomes more than 3 seconds. (Estimated value of throttle opening — output) throttle angle Engine speed Changing of manifold absolute pressure during 0.5 engine revs. Manifold absolute pressure	< 20.01° 1600 ↔ 3500 rpm < 1.30 kPa (9.76 mmHg, 0.384 inHg) 201.5 ↔ Atmospheric pressure -10.4 kPa (-78 mmHg, -3.07 inHg)
Low malfunction (2): Judge OK when the malfunction criteria below are completed. Throttle opening Elapsed time after engine starting	≥ 20.01° ≥ 5 seconds
High malfunction: Judge OK when the continuous time of completing the malfunction criteria below becomes more than 3 seconds. (Output — estimated value of throttle opening) throttle angle Engine speed Changing of manifold absolute pressure during 0.5 engine revs. Manifold absolute pressure	< 20.01° 1600 ↔ 3500 rpm < 1.30 kPa (9.76 mmHg, 0.384 inHg) 201.5 ↔ Atmospheric pressure -10.4 kPa (-78 mmHg, -3.07 inHg)

### 6. DTC CLEAR CONDITION

- When the OK idling cycle was completed 40 times in a row
- When “Clear Memory” was performed

### 7. MALFUNCTION INDICATOR LIGHT CLEAR CONDITION

- When the OK driving cycle was completed 3 times in a row
- When “Clear Memory” was performed

### 8. FAIL SAFE

#### ***Throttle position sensor process:***

- Fix the throttle opening at 6.4°.
- Fix the closed throttle position learning value at 0°.
- ISC open loop compensation: Fix the amount of ISC open loop compensation at 6.82%.
- ISC feedback compensation: Not allowed to calculate the amount of ISC feedback compensation.

### 9. ECM OPERATING AT DTC SETTING

Memorize the freeze frame data. (For test mode \$02)

# DIAGNOSTIC TROUBLE CODE (DTC) DETECTING CRITERIA

GENERAL DESCRIPTION

---

MEMO:

# DIAGNOSTIC TROUBLE CODE (DTC) DETECTING CRITERIA

## GENERAL DESCRIPTION

### R: DTC P0122 — THROTTLE/PEDAL POSITION SENSOR/SWITCH “A” CIRCUIT LOW INPUT —

#### 1. OUTLINE OF DIAGNOSIS

Detect the open or short circuit of throttle sensor.  
Judge NG when out of the standard value.

#### 2. COMPONENT DESCRIPTION

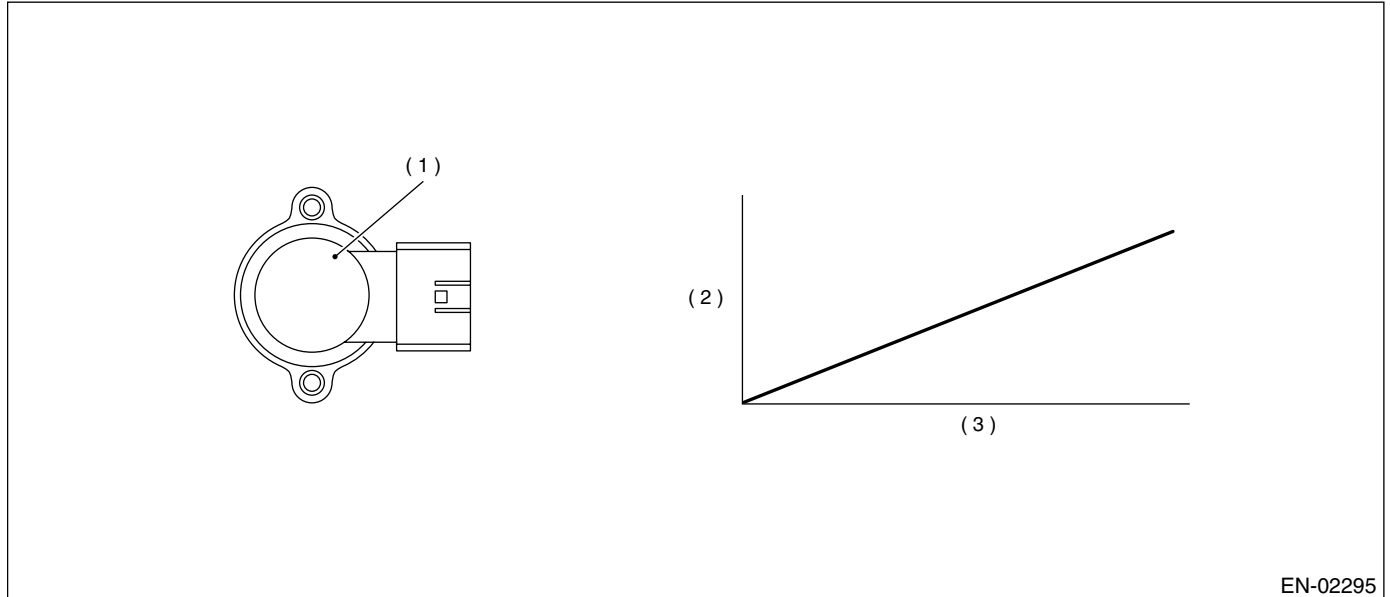

EN-02295

(1) Throttle position sensor

(2) Voltage (V)

(3) Throttle valve opening angle (°)

#### 3. ENABLE CONDITION

Secondary Parameters	Enable Conditions
None	

#### 4. GENERAL DRIVING CYCLE

Always perform the diagnosis continuously.

# DIAGNOSTIC TROUBLE CODE (DTC) DETECTING CRITERIA

GENERAL DESCRIPTION

## 5. DIAGNOSTIC METHOD

### • Abnormality Judgment

Judge NG when the continuous time of completing the malfunction criteria below becomes more than 0.5 seconds.

### • Judgment Value

Malfunction Criteria	Threshold Value
Output voltage	< 0.14 V
Ignition switch	ON

**Time Needed for Diagnosis:** 0.5 seconds

**Malfunction Indicator Light Illumination:** Illuminates as soon as the malfunction occurs.

### • Normality Judgment

Judge OK and clear the NG when the malfunction criteria below are completed.

### • Judgment Value

Malfunction Criteria	Threshold Value
Output voltage	$\geq 0.14$ V
Ignition switch	ON

## 6. DTC CLEAR CONDITION

- When the OK idling cycle was completed 40 times in a row
- When "Clear Memory" was performed

## 7. MALFUNCTION INDICATOR LIGHT CLEAR CONDITION

- When the OK driving cycle was completed 3 times in a row
- When "Clear Memory" was performed

## 8. FAIL SAFE

### **Throttle position sensor process:**

- Fix the throttle opening at  $6.4^\circ$ .
- Fix the closed throttle position learning value at  $0^\circ$ .
- ISC open loop compensation: Fix the amount of ISC open loop compensation at 6.82%.
- ISC feedback compensation: Not allowed to calculate the amount of ISC feedback compensation.

## 9. ECM OPERATING AT DTC SETTING

Memorize the freeze frame data. (For test mode \$02)

# DIAGNOSTIC TROUBLE CODE (DTC) DETECTING CRITERIA

## GENERAL DESCRIPTION

### S: DTC P0123 — THROTTLE/PEDAL POSITION SENSOR/SWITCH “A” CIRCUIT HIGH INPUT —

#### 1. OUTLINE OF DIAGNOSIS

Detect the open or short circuit of throttle sensor.  
Judge NG when out of the standard value.

#### 2. COMPONENT DESCRIPTION

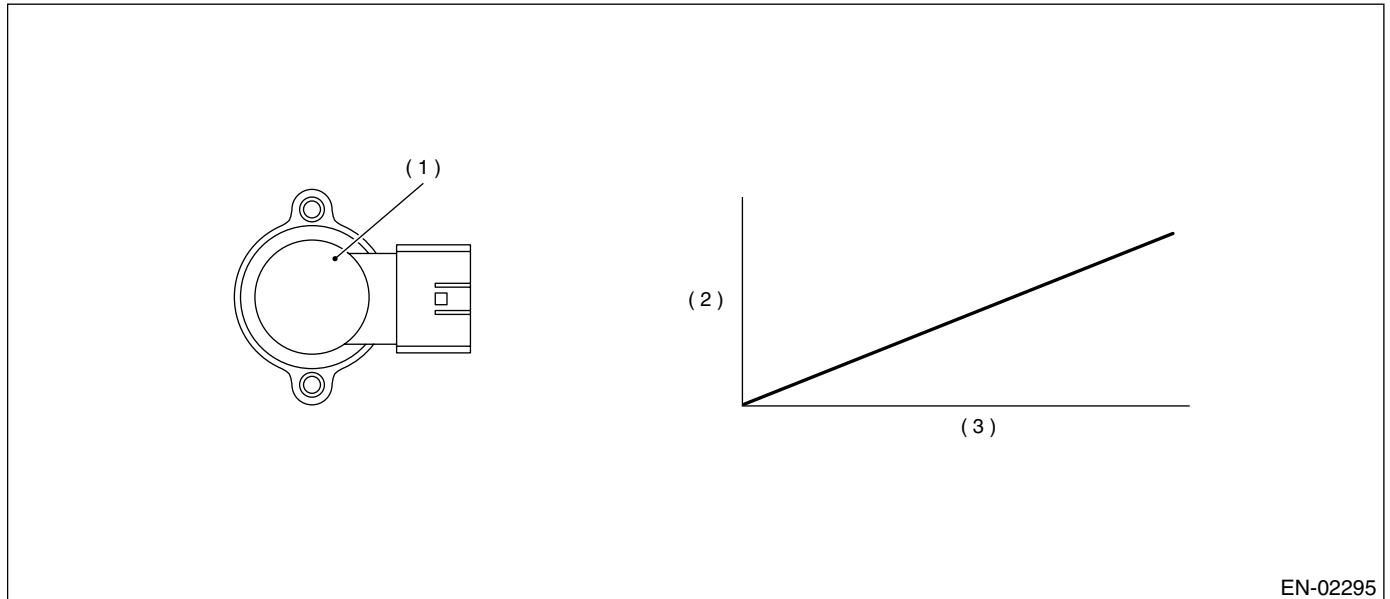

(1) Throttle position sensor

(2) Voltage (V)

(3) Throttle valve opening angle (°)

#### 3. ENABLE CONDITION

Secondary Parameters	Enable Conditions
None	

#### 4. GENERAL DRIVING CYCLE

Always perform the diagnosis continuously.

# DIAGNOSTIC TROUBLE CODE (DTC) DETECTING CRITERIA

GENERAL DESCRIPTION

## 5. DIAGNOSTIC METHOD

### • Abnormality Judgment

Judge NG when the continuous time of completing the malfunction criteria below becomes more than 0.5 seconds.

### • Judgment Value

Malfunction Criteria	Threshold Value
Output voltage	$\geq 4.72$ V
Ignition switch	ON

**Time Needed for Diagnosis:** 0.5 seconds

**Malfunction Indicator Light Illumination:** Illuminates as soon as the malfunction occurs.

### • Normality Judgment

Judge OK and clear the NG when the malfunction criteria below are completed.

### • Judgment Value

Malfunction Criteria	Threshold Value
Output voltage	$< 4.72$ V
Ignition switch	ON

## 6. DTC CLEAR CONDITION

- When the OK idling cycle was completed 40 times in a row
- When "Clear Memory" was performed

## 7. MALFUNCTION INDICATOR LIGHT CLEAR CONDITION

- When the OK driving cycle was completed 3 times in a row
- When "Clear Memory" was performed

## 8. FAIL SAFE

### **Throttle position sensor process:**

- Fix the throttle opening at  $6.4^\circ$ .
- Fix the closed throttle position learning value at  $0^\circ$ .
- ISC open loop compensation: Fix the amount of ISC open loop compensation at 6.82%.
- ISC feedback compensation: Not allowed to calculate the amount of ISC feedback compensation.

## 9. ECM OPERATING AT DTC SETTING

Memorize the freeze frame data. (For test mode \$02)

# DIAGNOSTIC TROUBLE CODE (DTC) DETECTING CRITERIA

## GENERAL DESCRIPTION

### T: DTC P0125 — INSUFFICIENT COOLANT TEMPERATURE FOR CLOSED LOOP FUEL CONTROL —

#### 1. OUTLINE OF DIAGNOSIS

Detect the malfunction of engine coolant temperature output property. Judge NG when the engine coolant temperature does not rise whereas it seemed to rise from the viewpoint of the engine condition.

#### 2. COMPONENT DESCRIPTION

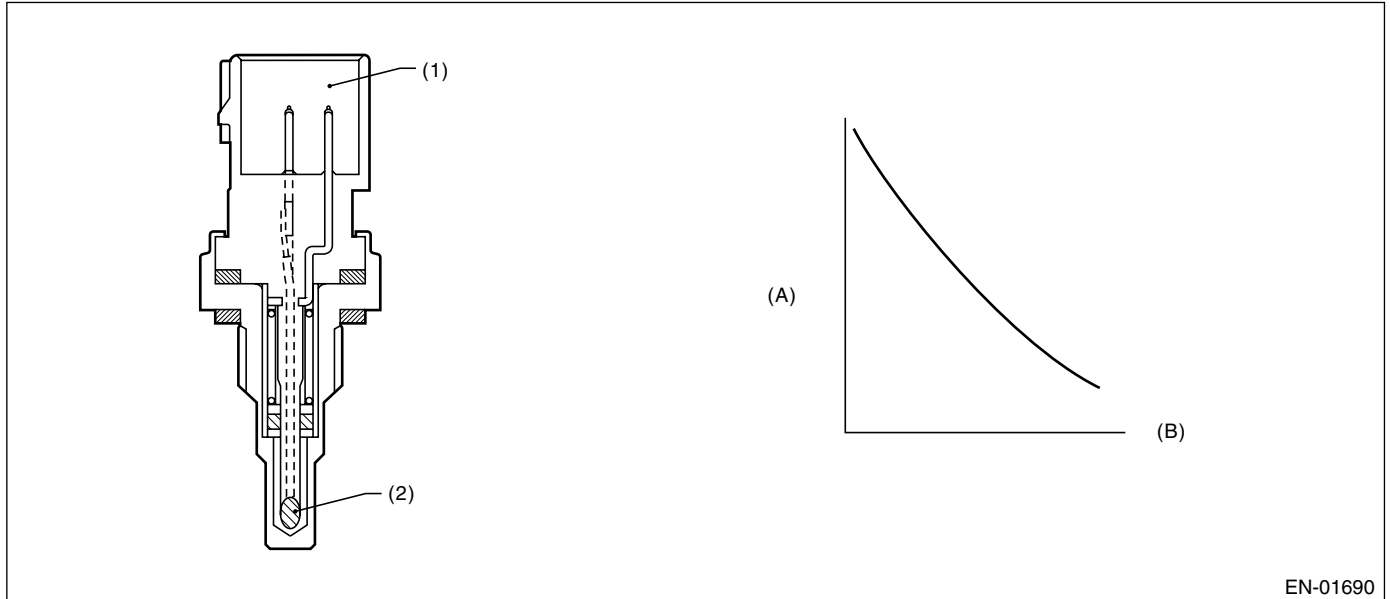

EN-01690

(1) Connector

(2) Thermistor element

(A) Resistance value (kΩ)

(B) Temperature °C (°F)

#### 3. ENABLE CONDITION

Secondary Parameters	Enable Conditions
Engine speed	≥ 500 rpm
Battery voltage	> 10.9 V

#### 4. GENERAL DRIVING CYCLE

Perform the diagnosis only once after engine starting.



# DIAGNOSTIC TROUBLE CODE (DTC) DETECTING CRITERIA

GENERAL DESCRIPTION

## 5. DIAGNOSTIC METHOD

### • Abnormality Judgment

Judge NG when the malfunction criteria below are completed.

### • Judgment Value

Malfunction Criteria	Threshold Value
Engine coolant temperature	< 20°C (68°F)
Timer for diagnosis after engine starting	≥ Timer judgment value after engine starting

Timer for diagnosis after engine starting

a) Timer stop at fuel cut mode.

b) During the driving conditions except a) above, timer count up by 65.5 milliseconds + TWCNT milliseconds at every 65.5 milliseconds.

Where, TWCNT is determined as follows,

TWCNT = 0 at idle switch ON,

TWCNT show on the following table at idle switch OFF.

Temp. °C (°F)	Vehicle speed km/h (MPH)							
	0 (0)	8 (4.97)	16 (9.94)	24 (14.9)	32 (19.9)	40 (24.9)	48 (29.8)	56 (34.8)
-20 (-4)	0 ms	1.75 ms	3.5 ms	5.25 ms	13.8 ms	10.5 ms	20.6 ms	27.5 ms
-10 (14)	0 ms	13.8 ms	20.6 ms	34.4 ms	55.1 ms	79.3 ms	61.9 ms	48.2 ms
0 (32)	0 ms	19.1 ms	48.2 ms	79.3 ms	123 ms	166 ms	144 ms	115 ms
10 (50)	0 ms	41.3 ms	82.6 ms	124 ms	193 ms	255 ms	227 ms	186 ms
20 (68)	0 ms	5.25 ms	10.5 ms	20.6 ms	41.3 ms	61.9 ms	96.3 ms	131 ms

Judgment value of timer after engine starting

$$t = 429.5 - 6.685 \times T_i$$

$T_i$  is the lowest coolant temperature after starting the engine.

**Time Needed for Diagnosis:** To be determined. (It is varied by the Min. engine coolant temperature and engine conditions such as vehicle speed and engine coolant temperature.)

**Malfunction Indicator Light Illumination:** Illuminates when malfunction occurs in 2 continuous driving cycles.

### • Normality Judgment

Judge OK and clear the NG when the malfunction criteria below are completed.

### • Judgment Value

Malfunction Criteria	Threshold Value
Engine coolant temperature	≥ 20°C (68°F)

## 6. DTC CLEAR CONDITION

- When the OK idling cycle was completed 40 times in a row
- When "Clear Memory" was performed

## 7. MALFUNCTION INDICATOR LIGHT CLEAR CONDITION

- When the OK driving cycle was completed 3 times in a row
- When "Clear Memory" was performed

# DIAGNOSTIC TROUBLE CODE (DTC) DETECTING CRITERIA

## GENERAL DESCRIPTION

---

### 8. FAIL SAFE

- Engine coolant temperature process: Fix the engine coolant temperature at 70°C (158°F).
- ISC feedback: Calculate the target engine speed setting the engine coolant temperature to 70°C (158°F).
- ISC learning: Not allowed to learn.
- Heavy fuel judgment control: Not allowed to carry out the heavy judgment.
- Air conditioner control: Not allowed to turn the air conditioner to ON.
- Radiator fan control: Both main and sub fan are in High driving.
- Increase compensation coefficient at a high water temperature: The water temperature condition is disregarded and increased by approval of other condition, though usually increases by a high water temperature and approval of other condition.

### 9. ECM OPERATING AT DTC SETTING

Memorize the freeze frame data. (For test mode \$02)

**DIAGNOSTIC TROUBLE CODE (DTC) DETECTING CRITERIA**

GENERAL DESCRIPTION

---

**MEMO:**

# DIAGNOSTIC TROUBLE CODE (DTC) DETECTING CRITERIA

## GENERAL DESCRIPTION

### U: DTC P0128 — COOLANT THERMOSTAT (COOLANT TEMPERATURE BELOW THERMOSTAT REGULATING TEMPERATURE) —

#### 1. OUTLINE OF DIAGNOSIS

Detect the malfunction of thermostat function. Judge NG when the engine coolant temperature is lower than the estimated engine coolant temperature and the difference between them is large. Judge OK when the engine coolant temperature becomes 75°C (167°F) and the difference is small before judging NG.

#### 2. COMPONENT DESCRIPTION

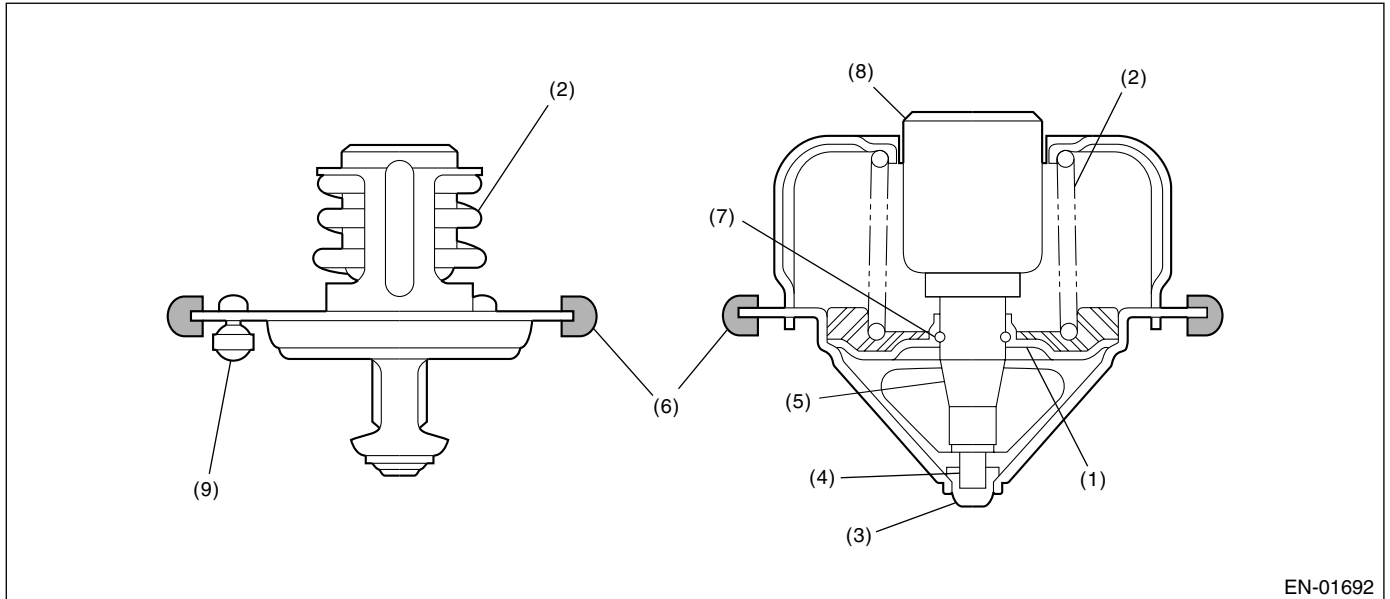

- |             |                    |                  |
|-------------|--------------------|------------------|
| (1) Valve   | (4) Piston         | (7) Stop ring    |
| (2) Spring  | (5) Guide          | (8) Wax element  |
| (3) Stopper | (6) Rubber packing | (9) Jiggle valve |

#### 3. ENABLE CONDITION

Secondary Parameters	Enable Conditions
None	

#### 4. GENERAL DRIVING CYCLE

Always perform the diagnosis continuously.

# DIAGNOSTIC TROUBLE CODE (DTC) DETECTING CRITERIA

GENERAL DESCRIPTION

## 5. DIAGNOSTIC METHOD

### • Abnormality Judgment

Judge NG when the continuous time of completing the malfunction criteria below becomes more than 30 seconds.

### • Judgment Value

Malfunction Criteria	Threshold Value
Battery voltage	$\geq 10.9$ V
Estimated ambient air temperature	$\geq -7^{\circ}\text{C}$ ( $19.4^{\circ}\text{F}$ )
Thermostat malfunction diagnosis	Not finished
Engine coolant temperature at engine starting	$< 55^{\circ}\text{C}$ ( $131^{\circ}\text{F}$ )
Estimated coolant temperature	$\geq 75^{\circ}\text{C}$ ( $167^{\circ}\text{F}$ )
Engine coolant temperature (Estimated – measured) coolant temperature	$\leq 75^{\circ}\text{C}$ ( $167^{\circ}\text{F}$ ) $> 20^{\circ}\text{C}$ ( $68^{\circ}\text{F}$ )

**Time Needed for Diagnosis:** 30 seconds

**Malfunction Indicator Light Illumination:** Illuminates when malfunction occurs in 2 continuous driving cycles.

### • Normality Judgment

Judge OK and clear the NG when the malfunction criteria below are completed.

### • Judgment Value

Malfunction Criteria	Threshold Value
Battery voltage	$\geq 10.9$ V
Estimated ambient air temperature	$\geq -7^{\circ}\text{C}$ ( $19.4^{\circ}\text{F}$ )
Thermostat malfunction diagnosis	Not finished
Engine coolant temperature at engine starting	$< 55^{\circ}\text{C}$ ( $131^{\circ}\text{F}$ )
Engine coolant temperature (Estimated – measured) coolant temperature	$\geq 75^{\circ}\text{C}$ ( $167^{\circ}\text{F}$ ) $\leq 20^{\circ}\text{C}$ ( $68^{\circ}\text{F}$ )

## 6. DTC CLEAR CONDITION

- When the OK idling cycle was completed 40 times in a row
- When “Clear Memory” was performed

## 7. MALFUNCTION INDICATOR LIGHT CLEAR CONDITION

- When the OK driving cycle was completed 3 times in a row
- When “Clear Memory” was performed

## 8. FAIL SAFE

None

## 9. ECM OPERATING AT DTC SETTING

- Memorize the freeze frame data. (For test mode \$02)
- Memorize the diagnostic value and trouble standard value. (For test mode \$06)

# DIAGNOSTIC TROUBLE CODE (DTC) DETECTING CRITERIA

## GENERAL DESCRIPTION

### V: DTC P0129 — BAROMETRIC PRESSURE TOO LOW —

#### 1. OUTLINE OF DIAGNOSIS

Detect the malfunction of atmospheric pressure sensor output property. Judge NG when the atmospheric pressure sensor output is largely different from the intake manifold pressure at engine starting.

#### 2. COMPONENT DESCRIPTION

Atmospheric pressure sensor is built in ECM.

#### 3. ENABLE CONDITION

Secondary Parameters	Enable Conditions
Engine speed at engine starting	< 300 rpm
Vehicle speed	< 1 km/h (0.62 MPH)
Diagnosis for atmospheric pressure sensor property	Not finished

#### 4. GENERAL DRIVING CYCLE

Perform the diagnosis once turning the ignition switch to ON.

#### 5. DIAGNOSTIC METHOD

##### • Abnormality Judgment

Judge NG when the continuous time of completing the malfunction criteria below becomes more than 0.3 seconds.

##### • Judgment Value

Malfunction Criteria	Threshold Value
Atmospheric – manifold absolute pressure	≥ 26.7 kPa (200 mmHg, 7.88 inHg)
Intake manifold pressure at engine starting – manifold absolute pressure	< 1.33 kPa (10 mmHg, 2.95 inHg)

**Time Needed for Diagnosis:** 0.3 seconds

**Malfunction Indicator Light Illumination:** Detect when malfunction occurs in 2 continuous driving cycles.

##### • Normality Judgment

Judge OK and clear the NG when the continuous time of completing the malfunction criteria below becomes more than 0.262 seconds.

##### • Judgment Value

Malfunction Criteria	Threshold Value
Atmospheric – manifold absolute pressure	< 26.7 kPa (200 mmHg, 7.88 inHg)

#### 6. DTC CLEAR CONDITION

- When the OK idling cycle was completed 40 times in a row
- When “Clear Memory” was performed

#### 7. MALFUNCTION INDICATOR LIGHT CLEAR CONDITION

- When the OK driving cycle was completed 3 times in a row
- When “Clear Memory” was performed

#### 8. FAIL SAFE

Atmospheric pressure sensor process: Fix the atmospheric pressure to 101 kPa (760 mmHg, 29.8 inHg).

#### 9. ECM OPERATING AT DTC SETTING

Memorize the freeze frame data. (For test mode \$02)

# DIAGNOSTIC TROUBLE CODE (DTC) DETECTING CRITERIA

GENERAL DESCRIPTION

---

MEMO:

# DIAGNOSTIC TROUBLE CODE (DTC) DETECTING CRITERIA

## GENERAL DESCRIPTION

### W: DTC P0130 — O<sub>2</sub> SENSOR CIRCUIT (BANK 1 SENSOR 1) —

#### 1. OUTLINE OF DIAGNOSIS

Detect the short circuit of front oxygen (A/F) sensor heater. Diagnosis is performed using front oxygen (A/F) sensor IC, and communication is established between front oxygen (A/F) sensor IC and main IC. Front oxygen (A/F) sensor judges NG when the data of voltage (AFC, AFV) is abnormal.

#### 2. COMPONENT DESCRIPTION

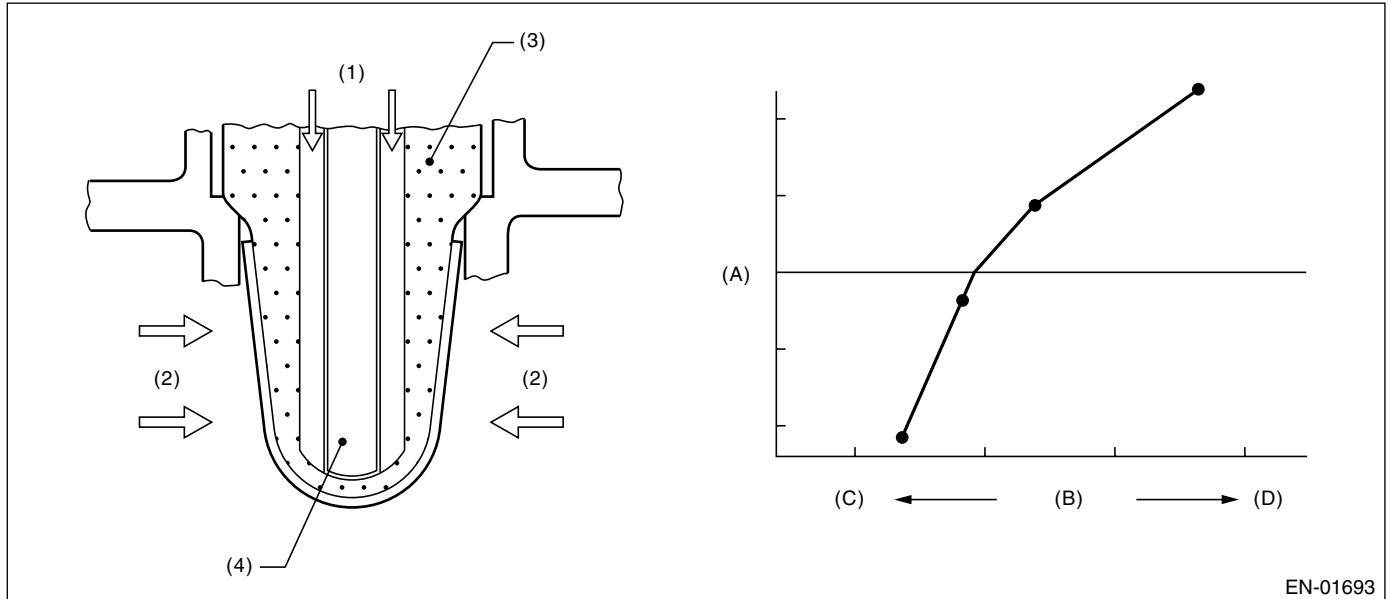

EN-01693

- |                      |                         |
|----------------------|-------------------------|
| (1) Atmosphere       | (A) Electromotive force |
| (2) Exhaust          | (B) Air fuel ratio      |
| (3) ZrO <sub>2</sub> | (C) Lean                |
| (4) Ceramic heater   | (D) Rich                |

#### 3. ENABLE CONDITION

Secondary Parameters	Enable Conditions
None	

#### 4. GENERAL DRIVING CYCLE

Always perform the diagnosis continuously.

#### 5. DIAGNOSTIC METHOD

Front oxygen (A/F) sensor judges NG when the continuous time of completing the malfunction criteria below becomes more than the time needed for diagnosis (4.6 seconds). Front oxygen (A/F) sensor judges OK and clear NG when the malfunction criteria below are not completed.

##### Judgment Value

Malfunction Criteria	Threshold Value
Output voltage	(Battery voltage short) AFC > 4.5 V or AFV > 4.95 V (Ground short) AFC < 3.5 V or AFV < 2.5 V

**Time Needed for Diagnosis:** 5 seconds

**Malfunction Indicator Light Illumination:** Illuminates as soon as the malfunction occurs.



# DIAGNOSTIC TROUBLE CODE (DTC) DETECTING CRITERIA

GENERAL DESCRIPTION

---

## 6. DTC CLEAR CONDITION

- When the OK idling cycle was completed 40 times in a row
- When "Clear Memory" was performed

## 7. MALFUNCTION INDICATOR LIGHT CLEAR CONDITION

- When the OK driving cycle was completed 3 times in a row
- When "Clear Memory" was performed

## 8. FAIL SAFE

- Front oxygen (A/F) sensor IC communication: Not allowed to communicate
- Front oxygen (A/F) sensor main learning correction: Not allowed to calculate
- Correction when re-starting at high temperature: Normally minimum value 0.06 → 0
- Purge control: Not allowed to purge

## 9. ECM OPERATING AT DTC SETTING

Memorize the freeze frame data. (For test mode \$02)

# DIAGNOSTIC TROUBLE CODE (DTC) DETECTING CRITERIA

## GENERAL DESCRIPTION

### X: DTC P0133 — O<sub>2</sub> SENSOR CIRCUIT SLOW RESPONSE (BANK 1 SENSOR 1) —

#### 1. OUTLINE OF DIAGNOSIS

Detect time-lag of front oxygen (A/F) sensor response. Front oxygen (A/F) sensor cover has some ventilation holes for exhaust gas. Clogged ventilation holes are diagnosed. When the holes are clogged, the A/F output variation becomes slow comparing with the actual A/F variation because oxygen which reaches the zirconia layer is insufficient. Therefore, if the cover has clogged holes, the rich to lean judgment in ECM is delayed when the change from rich to lean is caused.

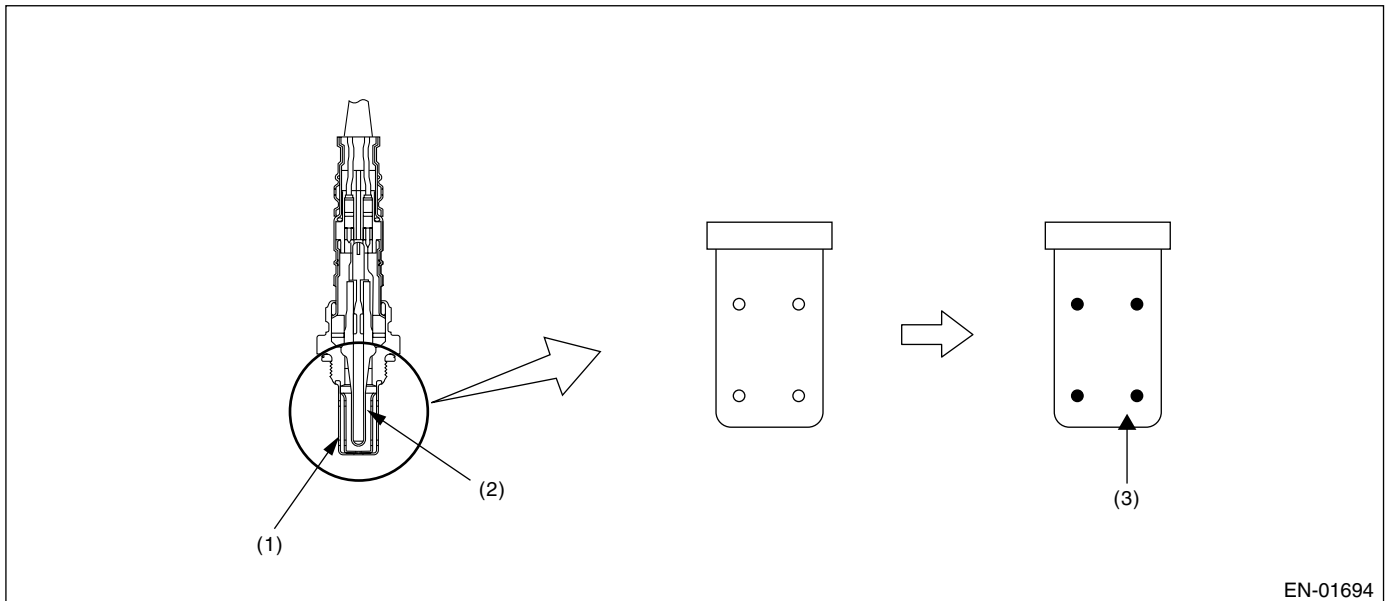

EN-01694

(1) Cover

(2) Zirconia

(3) Clogging

# DIAGNOSTIC TROUBLE CODE (DTC) DETECTING CRITERIA

GENERAL DESCRIPTION

## 2. COMPONENT DESCRIPTION

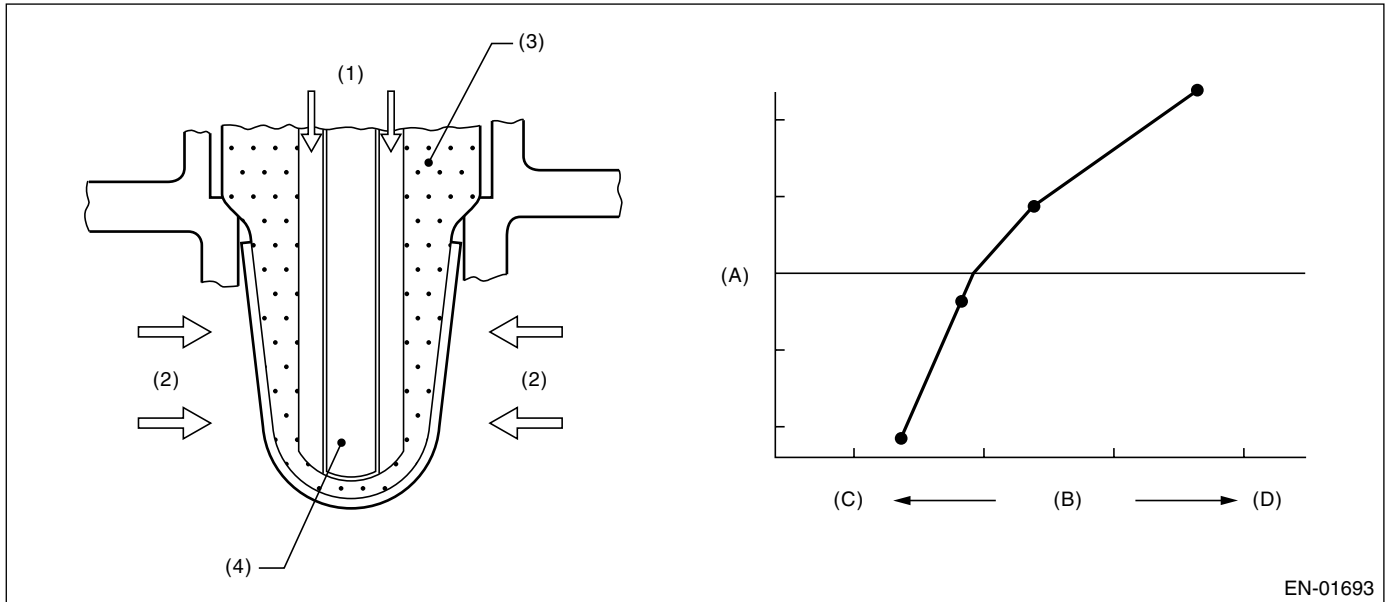

EN-01693

- |                      |                         |
|----------------------|-------------------------|
| (1) Atmosphere       | (A) Electromotive force |
| (2) Exhaust          | (B) Air fuel ratio      |
| (3) ZrO <sub>2</sub> | (C) Lean                |
| (4) Ceramic heater   | (D) Rich                |

## 3. ENABLE CONDITION

Secondary Parameters	Enable Conditions
All secondary parameters enable conditions	1 second or more
Battery voltage	> 10.9 V
Atmospheric pressure	> 75.1 kPa (563 mmHg, 22.2 inHg)
Closed loop control with main feedback operating	operating
Impedance of front oxygen (A/F) sensor	0 ↔ 52 Ω
After engine starting	60 seconds or more
Engine coolant temperature	≥ 75°C (167°F)
Engine speed	1000 ↔ 3200 rpm
Vehicle speed	10 ↔ 120 km/h (6.21 ↔ 74.6 MPH)
Amount of intake air	8 ↔ 40 g/s
Load variation during 0.5 engine revs.	≤ 1.95 kPa (14.6 mmHg, 0.575 inHg)
Purge control solenoid valve duty ratio	= 0% or ¼ 0%
All condition of EVAP canister purge	Execute
Learning value of EVAP conc. during purge	≤ 0.2
Total time of operating canister purge	20 seconds or more

## 4. GENERAL DRIVING CYCLE

Perform diagnosis only once at a constant speed of 10 to 120 km/h (6.21 to 74.6 MPH) in 60 seconds after starting the engine.

# DIAGNOSTIC TROUBLE CODE (DTC) DETECTING CRITERIA

## GENERAL DESCRIPTION

### 5. DIAGNOSTIC METHOD

Integrate the difference of  $f_{af}$  in every 128 milliseconds and difference of  $\lambda$  value.

After integrate 2343 times (300 seconds), calculate the diagnosis value.

Judge NG when the malfunction criteria below are completed. Judge OK and clear NG when the malfunction criteria below are not completed.

#### Judgment Value

Malfunction Criteria	Threshold Value
$para_{fca} = td2_{faf}/td2_{lmd}$ where, $td2_{faf}(N) = td2_{faf}(n-1) +  d2_{faf}(n) $ $td2_{lmd}(N) = td2_{lmd}(n-1) +  d2_{lmd}(n) $ add up for a total of 300 seconds $d2_{faf}(n) = (f_{af}(n) - f_{af}(n-1)) - (f_{af}(n-1) - f_{af}(n-2))$ $d2_{lmd}(n) = (l_{md}(n) - l_{md}(n-1)) - (l_{md}(n-1) - l_{md}(n-2))$ $f_{af}$ = main feedback compensation coefficient every 128 milliseconds $l_{md}$ = output lambda every 128 milliseconds	$\geq 0.25$

**Time Needed for Diagnosis:** 300 seconds

**Malfunction Indicator Light Illumination:** Illuminates when malfunction occurs in 2 continuous driving cycles.

### 6. DTC CLEAR CONDITION

- When the OK idling cycle was completed 40 times in a row
- When "Clear Memory" was performed

### 7. MALFUNCTION INDICATOR LIGHT CLEAR CONDITION

- When the OK driving cycle was completed 3 times in a row
- When "Clear Memory" was performed

### 8. FAIL SAFE

- Front oxygen (A/F) sensor main learning correction: Not allowed to calculate.
- Rear oxygen (A/F) sensor sub learning correction: Not allowed to calculate.
- Correction when re-starting at high temperature: Normally minimum value 0.06  $\rightarrow$  0.
- Purge control: Not allowed to purge.

### 9. ECM OPERATING AT DTC SETTING

- Memorize the freeze frame data. (For test mode \$02)
- Memorize the diagnostic value and trouble standard value. (For test mode \$06)

# DIAGNOSTIC TROUBLE CODE (DTC) DETECTING CRITERIA

GENERAL DESCRIPTION

---

MEMO:

# DIAGNOSTIC TROUBLE CODE (DTC) DETECTING CRITERIA

## GENERAL DESCRIPTION

### Y: DTC P0134 — O<sub>2</sub> SENSOR CIRCUIT NO ACTIVITY DETECTED (BANK 1 SENSOR 1) —

#### 1. OUTLINE OF DIAGNOSIS

Detect the open circuit of front oxygen (A/F) sensor heater. Diagnosis is performed using front oxygen (A/F) sensor IC, and communication is established between front oxygen (A/F) sensor IC and main IC. Front oxygen (A/F) sensor judges NG when the impedance of front oxygen (A/F) sensor is abnormal.

#### 2. COMPONENT DESCRIPTION

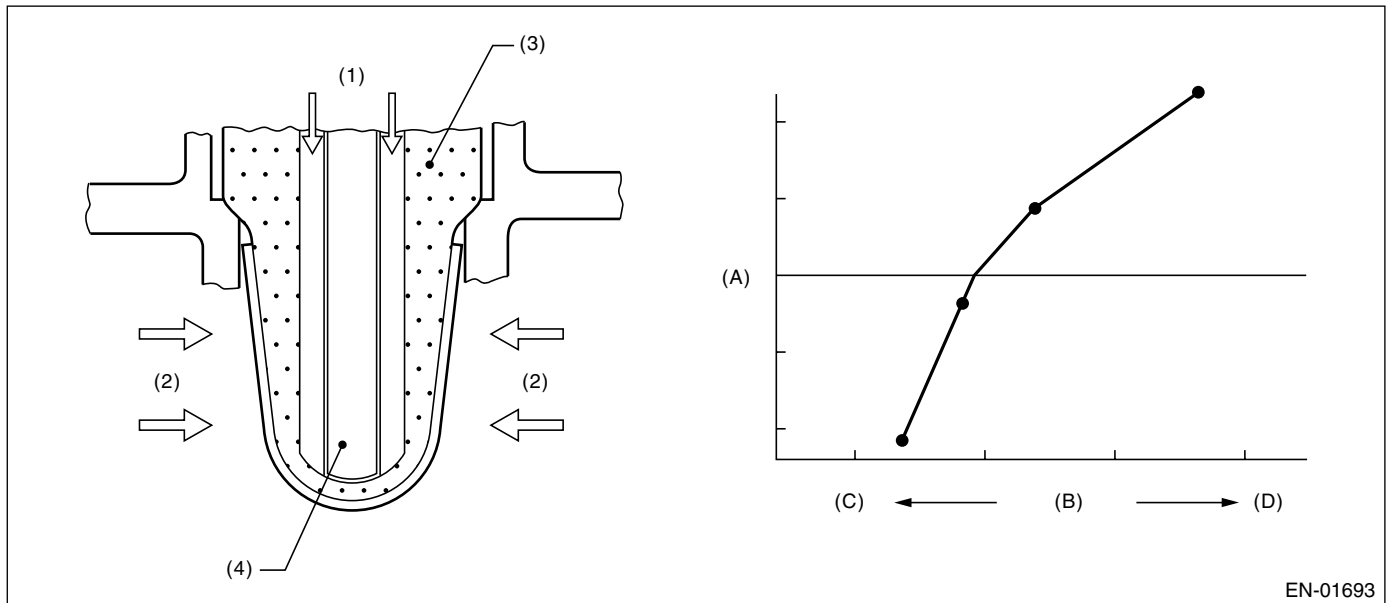

EN-01693

- |                      |                         |
|----------------------|-------------------------|
| (1) Atmosphere       | (A) Electromotive force |
| (2) Exhaust          | (B) Air fuel ratio      |
| (3) ZrO <sub>2</sub> | (C) Lean                |
| (4) Ceramic heater   | (D) Rich                |

#### 3. ENABLE CONDITION

Secondary Parameters	Enable Conditions
None	

#### 4. GENERAL DRIVING CYCLE

Always perform the diagnosis continuously.

#### 5. DIAGNOSTIC METHOD

Front oxygen (A/F) sensor judges NG when the continuous time until completing the malfunction criteria below becomes more than the time needed for diagnosis (5 seconds). Front oxygen (A/F) sensor judges OK and clear NG when the malfunction criteria below are not completed.

##### Judgment Value

Malfunction Criteria	Threshold Value
Impedance of front oxygen (A/F) sensor (open circuit)	> 500 Ω

**Time Needed for Diagnosis:** 5 seconds

**Malfunction Indicator Light Illumination:** Illuminates as soon as the malfunction occurs.

# DIAGNOSTIC TROUBLE CODE (DTC) DETECTING CRITERIA

GENERAL DESCRIPTION

---

## 6. DTC CLEAR CONDITION

- When the OK idling cycle was completed 40 times in a row
- When "Clear Memory" was performed

## 7. MALFUNCTION INDICATOR LIGHT CLEAR CONDITION

- When the OK driving cycle was completed 3 times in a row
- When "Clear Memory" was performed

## 8. FAIL SAFE

- Front oxygen (A/F) sensor IC communication: Not allowed to communicate
- Front oxygen (A/F) sensor main learning correction: Not allowed to calculate
- Correction when re-starting at high temperature: Normally minimum value 0.06 → 0.
- Purge control: Not allowed to purge

## 9. ECM OPERATING AT DTC SETTING

Memorize the freeze frame data. (For test mode \$02)

# DIAGNOSTIC TROUBLE CODE (DTC) DETECTING CRITERIA

## GENERAL DESCRIPTION

### Z: DTC P0137 — O<sub>2</sub> SENSOR CIRCUIT LOW VOLTAGE (BANK 1 SENSOR 2) —

#### 1. OUTLINE OF DIAGNOSIS

Detect the malfunction of rear oxygen sensor open or short circuit. Judge NG when the rear oxygen sensor voltage may be abnormal from rear oxygen sensor voltage value with considering the conditions such as intake air amount, engine coolant temperature, main feedback control.

#### 2. COMPONENT DESCRIPTION

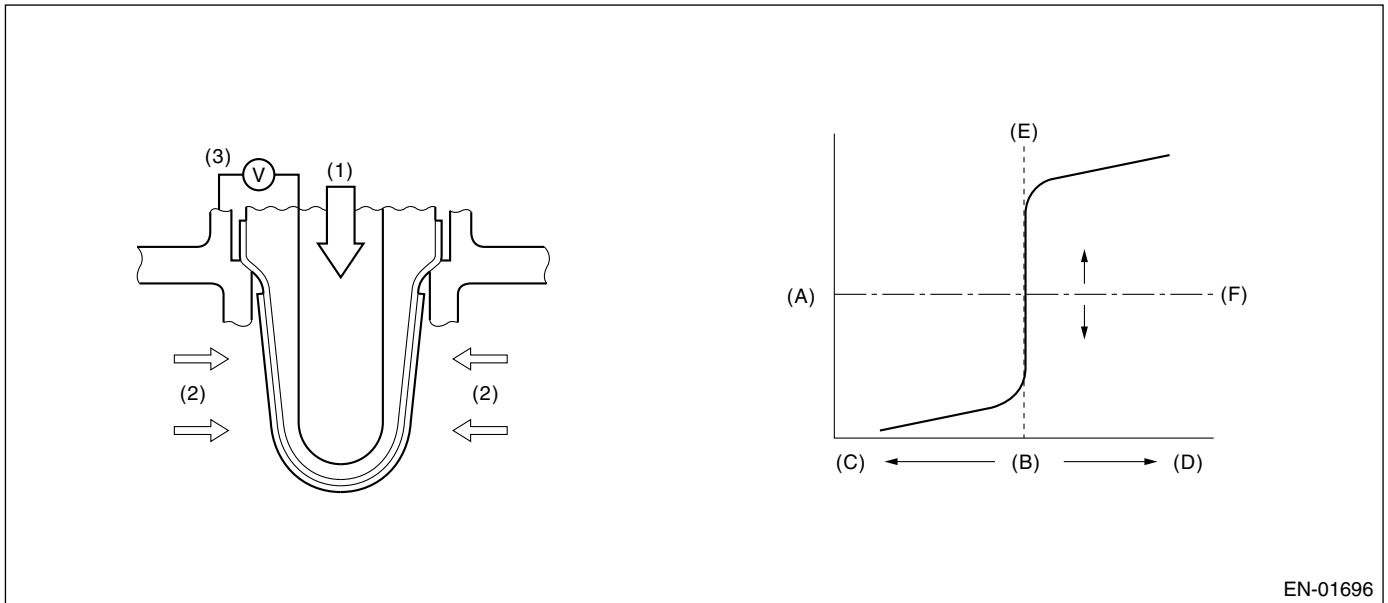

EN-01696

- |                         |                         |                                |
|-------------------------|-------------------------|--------------------------------|
| (1) Atmosphere          | (A) Electromotive force | (D) Lean                       |
| (2) Exhaust             | (B) Air fuel ratio      | (E) Theoretical air fuel ratio |
| (3) Electromotive force | (C) Rich                | (F) Comparative voltage        |

#### 3. ENABLE CONDITION (USED ONLY FOR MALFUNCTION JUDGMENT)

Secondary Parameters	Enable Conditions
Closed loop control with rear oxygen sensor	In operation
Target output voltage of rear oxygen sensor	$\geq 0.55$ V
Amount of intake air	$\geq 10$ g/s
Engine coolant temperature	$\geq 75^{\circ}\text{C}$ ( $167^{\circ}\text{F}$ )
Misfire detection during 200 engine revs.	$\leq 6$ times
Compensation factor for front oxygen (A/F) sensor with main feedback control	Not in limit value
Battery voltage with main feedback control	$> 10.9$ V
5 seconds or more fuel shut-off in decel.	Experienced

#### 4. GENERAL DRIVING CYCLE

Perform the diagnosis once after starting the engine.



# DIAGNOSTIC TROUBLE CODE (DTC) DETECTING CRITERIA

GENERAL DESCRIPTION

## 5. DIAGNOSTIC METHOD

### • Abnormality Judgment

Judge NG when the malfunction criteria below are completed.

### • Judgment Value

Malfunction Criteria	Threshold Value
Max. output voltage	< 500 mV

**Time Needed for Diagnosis:** 200 seconds

**Malfunction Indicator Light Illumination:** Illuminates when malfunction occurs in 2 continuous driving cycles.

### • Normality Judgment

Judge OK when the malfunction criteria below are completed.

### • Judgment Value

Malfunction Criteria	Threshold Value
Low side diagnosis of rear oxygen sensor voltage	Incomplete
Max. output voltage	$\geq 500$ mV

## 6. DTC CLEAR CONDITION

- When the OK idling cycle was completed 40 times in a row
- When "Clear Memory" was performed

## 7. MALFUNCTION INDICATOR LIGHT CLEAR CONDITION

- When the OK driving cycle was completed 3 times in a row
- When "Clear Memory" was performed

## 8. FAIL SAFE

Sub feedback control: Not allowed

## 9. ECM OPERATING AT DTC SETTING

Memorize the freeze frame data. (For test mode \$02)

# DIAGNOSTIC TROUBLE CODE (DTC) DETECTING CRITERIA

## GENERAL DESCRIPTION

### AA:DTC P0138 — O<sub>2</sub> SENSOR CIRCUIT HIGH VOLTAGE (BANK 1 SENSOR 2) —

#### 1. OUTLINE OF DIAGNOSIS

Detect the malfunction of rear oxygen sensor open or short circuit. Judge NG when the rear oxygen sensor voltage may be abnormal with considering the conditions such as intake air amount, engine coolant temperature, main feedback control.

#### 2. COMPONENT DESCRIPTION

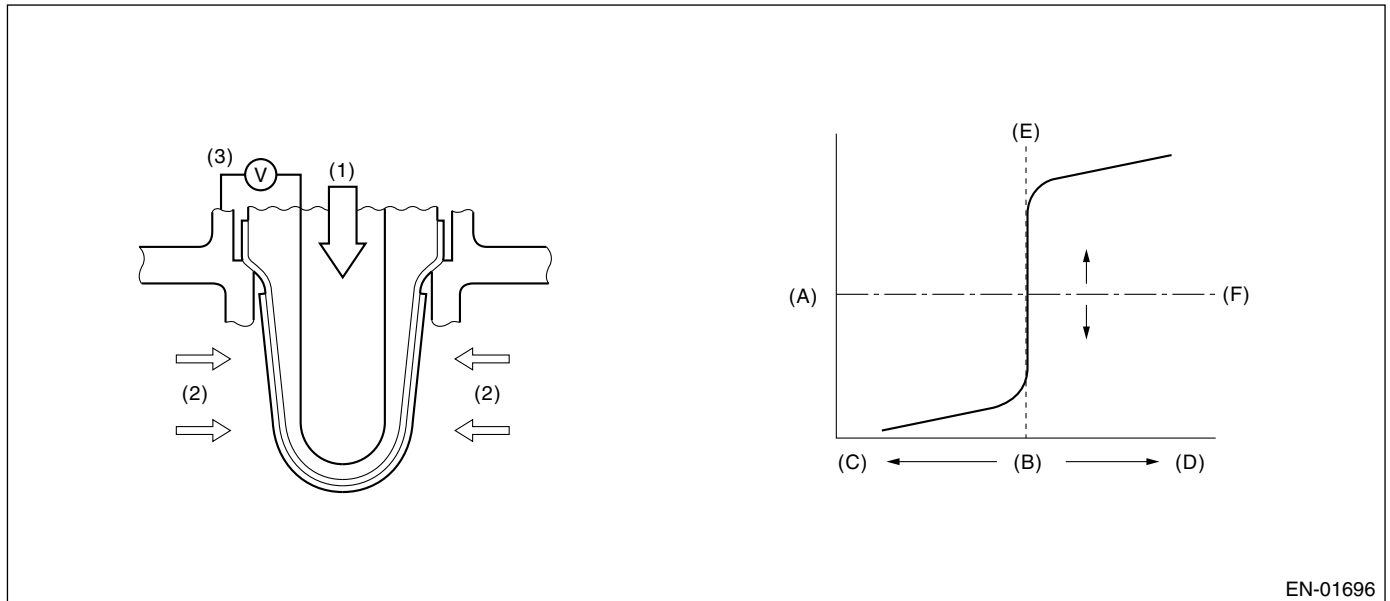

EN-01696

- |                         |                         |                                |
|-------------------------|-------------------------|--------------------------------|
| (1) Atmosphere          | (A) Electromotive force | (D) Lean                       |
| (2) Exhaust             | (B) Air fuel ratio      | (E) Theoretical air fuel ratio |
| (3) Electromotive force | (C) Rich                | (F) Comparative voltage        |

#### 3. ENABLE CONDITION (USED ONLY FOR MALFUNCTION JUDGMENT)

Secondary Parameters	Enable Conditions
Closed loop control with rear oxygen sensor	In operation
Target output voltage of rear oxygen sensor	$\geq 0.55$ V
Amount of intake air	$\geq 10$ g/s
Engine coolant temperature	$\geq 75^{\circ}\text{C}$ ( $167^{\circ}\text{F}$ )
Misfire detection during 200 engine revs.	$\leq 6$ times
Compensation factor for front oxygen (A/F) sensor	Not in limit value
Battery voltage with main feedback control	$> 10.9$ V
5 seconds or more fuel shut-off in decel.	Experienced

#### 4. GENERAL DRIVING CYCLE

Perform the diagnosis once after starting the engine.

# DIAGNOSTIC TROUBLE CODE (DTC) DETECTING CRITERIA

GENERAL DESCRIPTION

## 5. DIAGNOSTIC METHOD

### • Abnormality Judgment

Judge NG when the malfunction criteria below are completed.

### • Judgment Value

Malfunction Criteria	Threshold Value
Min. output voltage	> 200 mV

**Time Needed for Diagnosis:** 200 seconds

**Malfunction Indicator Light Illumination:** Detect when malfunction occurs in 2 continuous driving cycles.

### • Normality Judgment

Judge OK when the malfunction criteria below are completed.

### • Judgment Value

Malfunction Criteria	Threshold Value
High side diagnosis of rear oxygen sensor voltage	Incomplete
Min. output voltage	$\leq$ 200 mV

## 6. DTC CLEAR CONDITION

- When the OK idling cycle was completed 40 times in a row
- When "Clear Memory" was performed

## 7. MALFUNCTION INDICATOR LIGHT CLEAR CONDITION

- When the OK driving cycle was completed 3 times in a row
- When "Clear Memory" was performed

## 8. FAIL SAFE

Sub feedback control: Not allowed

## 9. ECM OPERATING AT DTC SETTING

Memorize the freeze frame data. (For test mode \$02)

# DIAGNOSTIC TROUBLE CODE (DTC) DETECTING CRITERIA

## GENERAL DESCRIPTION

### AB:DTC P0139 — O<sub>2</sub> SENSOR CIRCUIT SLOW RESPONSE (BANK 1 SENSOR 2) —

#### 1. OUTLINE OF DIAGNOSIS

Detect the slow response of rear oxygen sensor.

##### • Diagnostic Method

Measure the response time of the output change of the rear oxygen sensor when the A/F ratio changes from rich to lean. And Judge NG when the measured response time is larger than the threshold value.

#### 2. COMPONENT DESCRIPTION

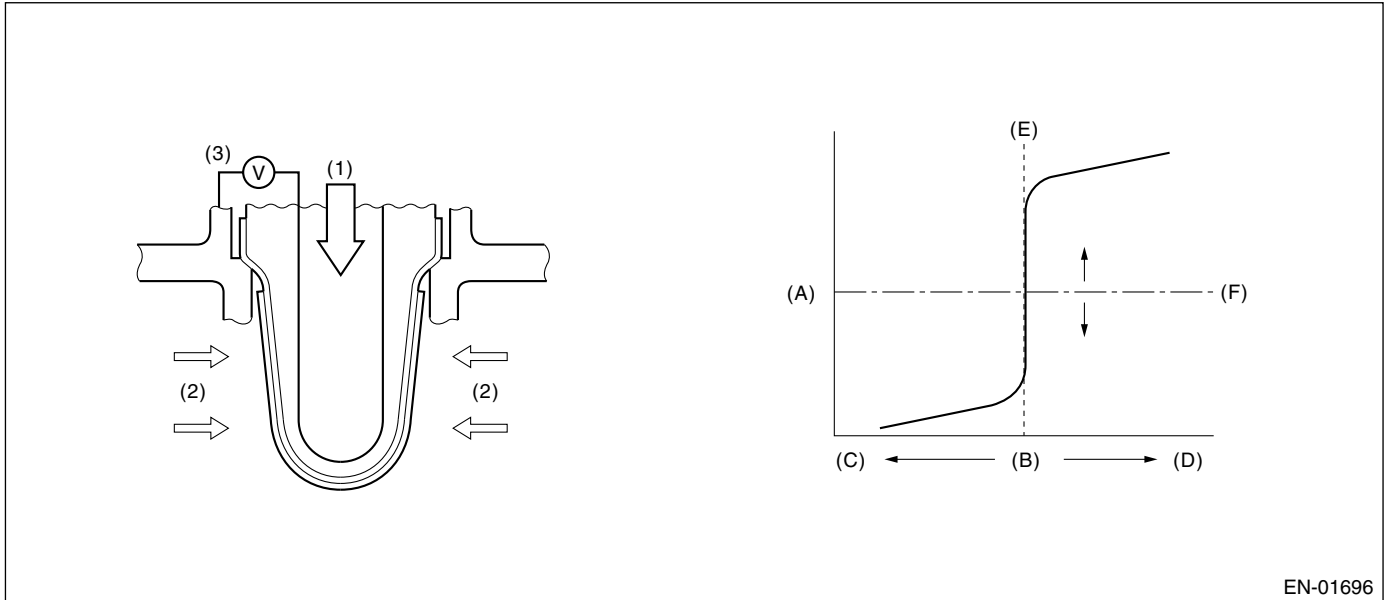

EN-01696

- (1) Atmosphere
- (2) Exhaust
- (3) Electromotive force

- (A) Electromotive force
- (B) Air fuel ratio
- (C) Rich

- (D) Lean
- (E) Theoretical air fuel ratio
- (F) Comparative voltage

#### 3. ENABLE CONDITION

Secondary Parameters	Enable Conditions
Battery voltage	> 10.9 V
Closed loop control with rear oxygen sensor	In operation
5 seconds or more fuel shut-off at deceleration	Experienced
After fuel shut-off	≥ 2 seconds

#### 4. GENERAL DRIVING CYCLE

Perform the diagnosis only once when fuel shut-off in deceleration after rapid acceleration. (Pay attention to oxygen sensor voltage for the timing of deceleration in order to calculate the diagnostic value.)

# DIAGNOSTIC TROUBLE CODE (DTC) DETECTING CRITERIA

GENERAL DESCRIPTION

## 5. DIAGNOSTIC METHOD

When the rear oxygen sensor output voltage changes from 0.5 V (rich) to 0.2 V (lean), calculate the Min. value of response time regarded as judgment value while the output varies from 0.45 V to 0.25 V.

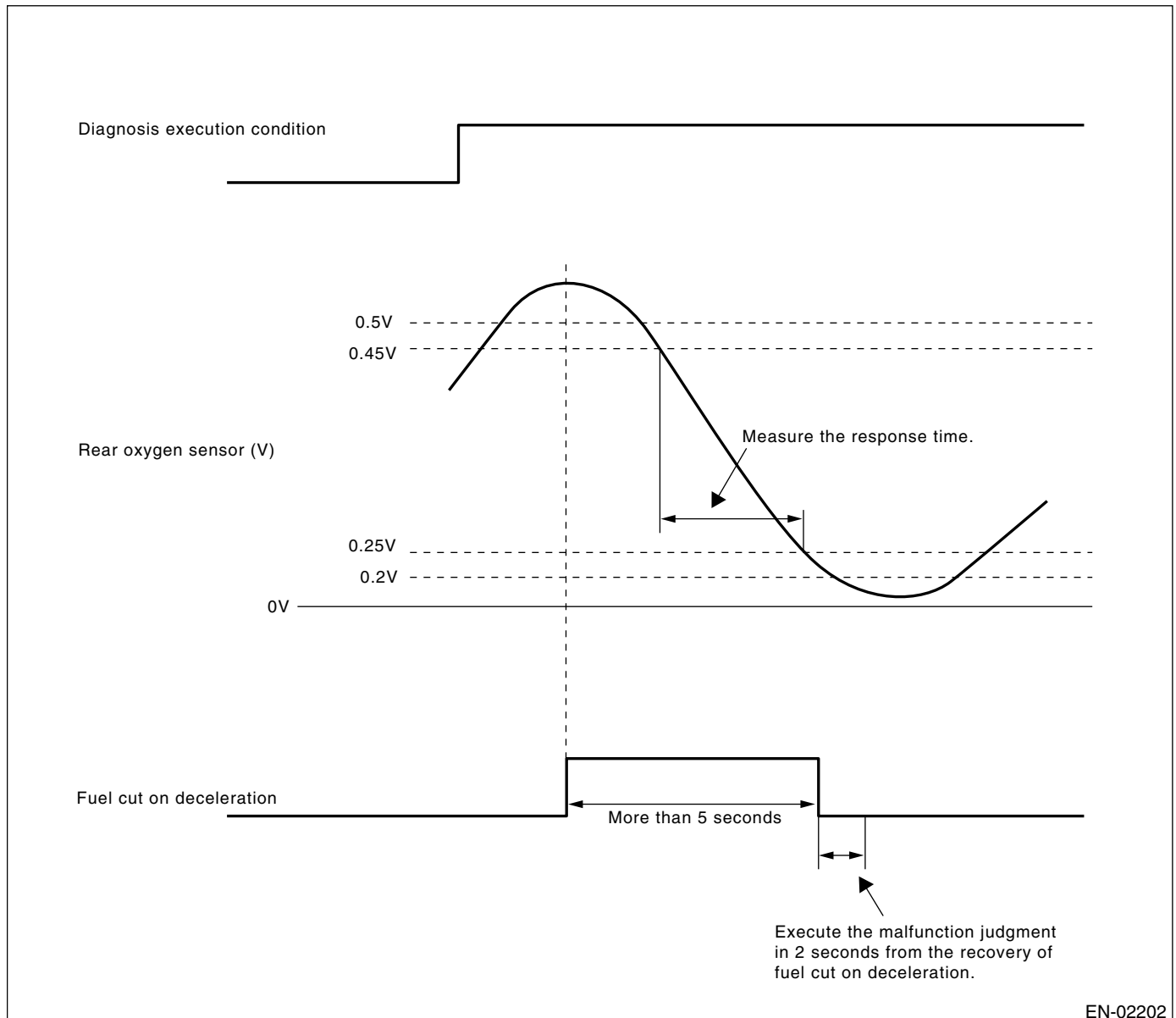

### • Abnormality Judgment

Judge NG when the judgment value is larger than the threshold value after fuel shut-off in deceleration.  
Response time (Diagnosis value) > Threshold value → Abnormal

#### NOTE:

Variation time of rear oxygen sensor output voltage is short during fuel shut-off in deceleration. Carry out the NG judgment only after the fuel shut-off in deceleration. As for OK judgment, without the condition of fuel shut-off in deceleration, judge OK if the value is below the threshold value.

Judge NG when the malfunction criteria below are completed in 5 seconds after the recovery of fuel shut-off in deceleration which requires 5 seconds or more. Judge OK when the malfunction criteria below are not completed regardless of the fuel shut-off in deceleration.

# DIAGNOSTIC TROUBLE CODE (DTC) DETECTING CRITERIA

## GENERAL DESCRIPTION

---

### • Judgment Value

Judge NG when the malfunction criteria below are completed.

Malfunction Criteria	Threshold Value
Shortest time change from rich (450 mV O <sub>2</sub> output) to lean (250 mV) if voltage reduces from 500 mV to 200 mV.	≥ 327 milliseconds

**Time Needed for Diagnosis:** 5 seconds

**Malfunction Indicator Light Illumination:** Illuminates when malfunction occurs in 2 continuous driving cycles.

### 6. DTC CLEAR CONDITION

- When the OK idling cycle was completed 40 times in a row
- When "Clear Memory" was performed

### 7. MALFUNCTION INDICATOR LIGHT CLEAR CONDITION

- When the OK driving cycle was completed 3 times in a row
- When "Clear Memory" was performed

### 8. FAIL SAFE

Sub feedback control: Not allowed

### 9. ECM OPERATING AT DTC SETTING

- Memorize the freeze frame data. (For test mode \$02)
- Memorize the diagnostic value and trouble standard value. (For test mode \$06)

# DIAGNOSTIC TROUBLE CODE (DTC) DETECTING CRITERIA

GENERAL DESCRIPTION

---

## **AC:DTC P0150 — O2 SENSOR CIRCUIT (BANK 1 SENSOR 1) —**

### NOTE:

For detecting condition, refer to DTC P0130. <Ref. to GD(H6DO)-56, DTC P0130 — O2 SENSOR CIRCUIT (BANK 1 SENSOR 1) —, Diagnostic Trouble Code (DTC) Detecting Criteria.>

## **AD:DTC P0153 — O2 SENSOR CIRCUIT SLOW RESPONSE (BANK 2 SENSOR 1) —**

### NOTE:

For detecting condition, refer to DTC P0133. <Ref. to GD(H6DO)-58, DTC P0133 — O2 SENSOR CIRCUIT SLOW RESPONSE (BANK 1 SENSOR 1) —, Diagnostic Trouble Code (DTC) Detecting Criteria.>

## **AE:DTC P0154 — O2 SENSOR CIRCUIT NO ACTIVITY DETECTED (BANK 2 SENSOR 1) —**

### NOTE:

For detecting condition, refer to DTC P0134. <Ref. to GD(H6DO)-62, DTC P0134 — O2 SENSOR CIRCUIT NO ACTIVITY DETECTED (BANK 1 SENSOR 1) —, Diagnostic Trouble Code (DTC) Detecting Criteria.>

# DIAGNOSTIC TROUBLE CODE (DTC) DETECTING CRITERIA

## GENERAL DESCRIPTION

### AF:DTC P0171 — SYSTEM TOO LEAN (BANK 1) —

#### 1. OUTLINE OF DIAGNOSIS

Detect the fuel system malfunction by the amount of main feedback control.

#### • Fuel System Diagnosis

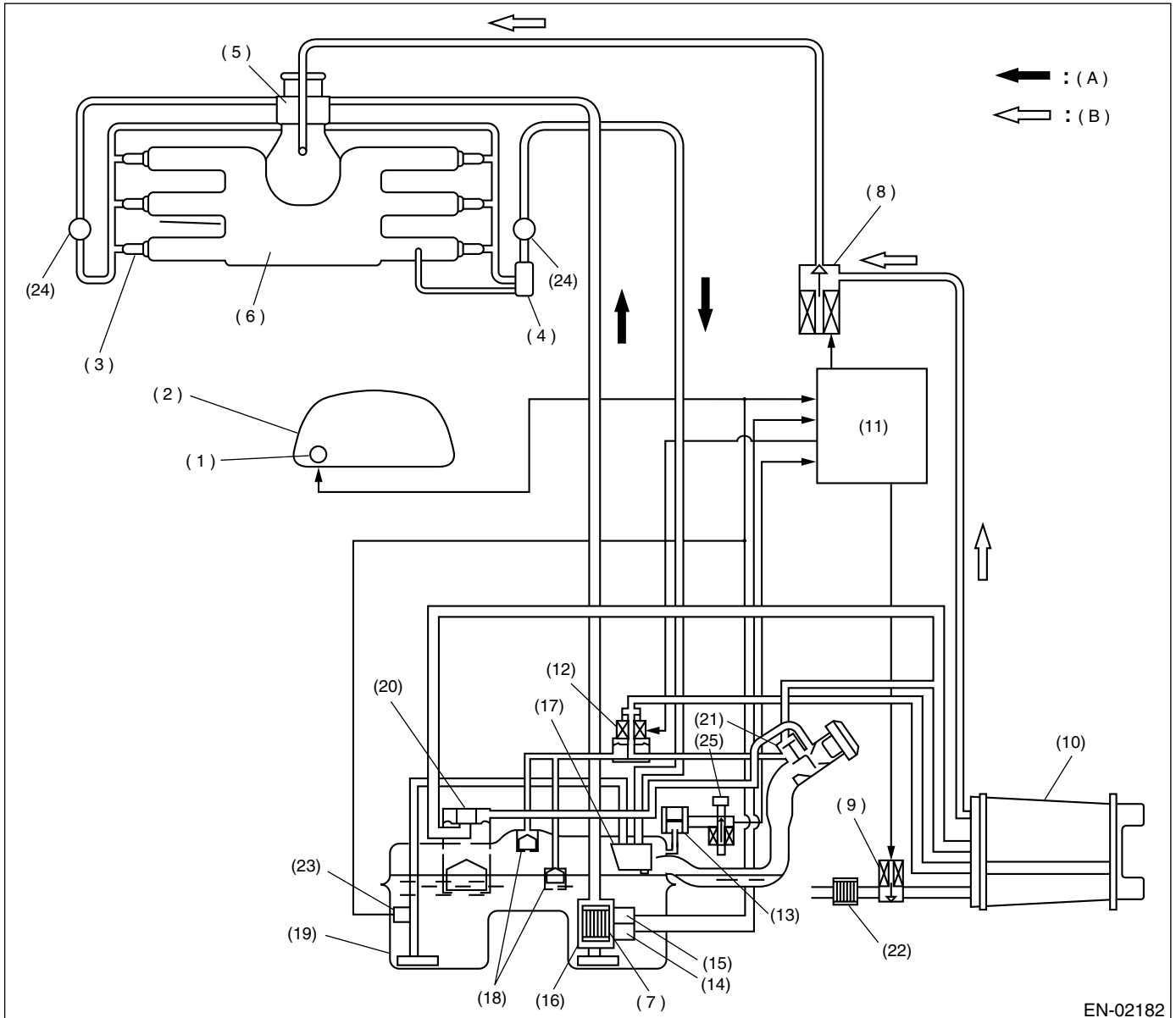

EN-02182

- |                                  |                                      |   |
|----------------------------------|--------------------------------------|---|
| (1) Fuel meter                   | (11) Engine control module (ECM)     | (21) Shut-off valve                         |
| (2) Combination meter            | (12) Pressure control solenoid valve | (22) Drain filter                           |
| (3) Fuel injector                | (13) Fuel tank pressure sensor       | (23) Fuel sub level sensor                  |
| (4) Pressure regulator           | (14) Fuel temperature sensor         | (24) Fuel damper                            |
| (5) Throttle body                | (15) Fuel level sensor               | (25) Tank pressure switching solenoid valve |
| (6) Intake manifold              | (16) Fuel pump                       | (A) Fuel line                               |
| (7) Fuel filter                  | (17) Jet pump                        | (B) Evaporation line                        |
| (8) Purge control solenoid valve | (18) Fuel cut valve                  |   |
| (9) Drain valve                  | (19) Fuel tank                       |   |
| (10) Canister                    | (20) Vent valve                      |   |



# DIAGNOSTIC TROUBLE CODE (DTC) DETECTING CRITERIA

GENERAL DESCRIPTION

## • Diagnostic Method

Fuel system is diagnosed by comparing the target air fuel ratio calculated by ECM with the actual air fuel ratio measured by sensor.

## 2. ENABLE CONDITION

Secondary Parameters	Enable Conditions
A/F main learning system	In operation
Engine coolant temperature	75 ↔ 119 °C (167 ↔ 246°F)
Change of intake pressure every 0.5 engine rev.	< 1.9 kPa (14 mmHg, 0.55 inHg)
Learning value of EVAP conc. during purge	≤ 0.1
Cumulative time of canister purge after engine start	20 seconds or more
Continuous period after canister purge starting	10 seconds or more
Intake manifold absolute pressure	≤ Map 1

### Map 1

Engine speed (rpm)	Idling	800	1200	1600	2000	2400	2800	3200	3600	4000	4400
Intake manifold absolute pressure kPa (mmHg, inHg)	na	30.1 (226, 8.90)	23.9 (179, 7.05)	23.3 (175, 6.89)	24.0 (180, 7.09)	23.1 (173, 6.81)	24.7 (185, 7.28)	26.8 (201, 7.91)	28.9 (217, 8.54)	31.2 (234, 9.21)	33.3 (250, 9.84)

## 3. GENERAL DRIVING CYCLE

Perform the diagnosis continuously idling after warm-up or at a constant vehicle speed.

## 4. DIAGNOSTIC METHOD

### • Abnormality Judgment

Judge that the fuel system malfunction occurs when the time during completing the malfunction criteria below continues 30 seconds or more by comparing the diagnosed value (fsobd) with threshold value.

### • Judgment Value

Malfunction Criteria	Threshold Value
$fsobd = (sglmd - tglmda) + faf + flaf$ where, sglmd = measured lambda tglmda = target lambda  faf = main feedback compensation coefficient every 64 milliseconds flaf = main feedback learning compensation coefficient	≥ fsobdL1 See Map 4  fsobdL1 = lean side threshold value of fsobd

### Map 4 Threshold value for fuel system malfunction criteria

Amount of air (g (oz)/s)	0 (0)	3.2 (0.113)	6.4 (0.226)	9.6 (0.339)	12.8 (0.451)	16 (0.564)	19.2 (0.677)
fsobdL1 (%)	40	40	33.2	26.5	26.5	26.5	26.5

**Time Needed for Diagnosis:** 10 seconds × 3 times

**Malfunction Indicator Light Illumination:** Illuminates when malfunction occurs in 2 continuous driving cycles.

# DIAGNOSTIC TROUBLE CODE (DTC) DETECTING CRITERIA

## GENERAL DESCRIPTION

---

- **Normality Judgment**

Judge OK when the malfunction criteria below are continued for 10 seconds.

- **Judgment Value**

Malfunction Criteria	Threshold Value
$fsobd = (sglmd - tglmda) + faf + flaf$	< 19%

### 5. DTC CLEAR CONDITION

- When the OK idling cycle was completed 40 times in a row
- When "Clear Memory" was performed

### 6. MALFUNCTION INDICATOR LIGHT CLEAR CONDITION

- When OK with similar drive in 3 driving cycles.
- When "Clear Memory" was performed

### 7. FAIL SAFE

### 8. ECM OPERATING AT DTC SETTING

- Memorize the freeze frame data. (For test mode \$02)
- Memorize the diagnostic value and trouble standard value. (For test mode \$06)

# DIAGNOSTIC TROUBLE CODE (DTC) DETECTING CRITERIA

GENERAL DESCRIPTION

---

MEMO:

# DIAGNOSTIC TROUBLE CODE (DTC) DETECTING CRITERIA

## GENERAL DESCRIPTION

### AG:DTC P0172 — SYSTEM TOO RICH (BANK 1) —

#### 1. OUTLINE OF DIAGNOSIS

Detect the fuel system malfunction by the amount of main feedback control.

##### • Fuel System Diagnosis

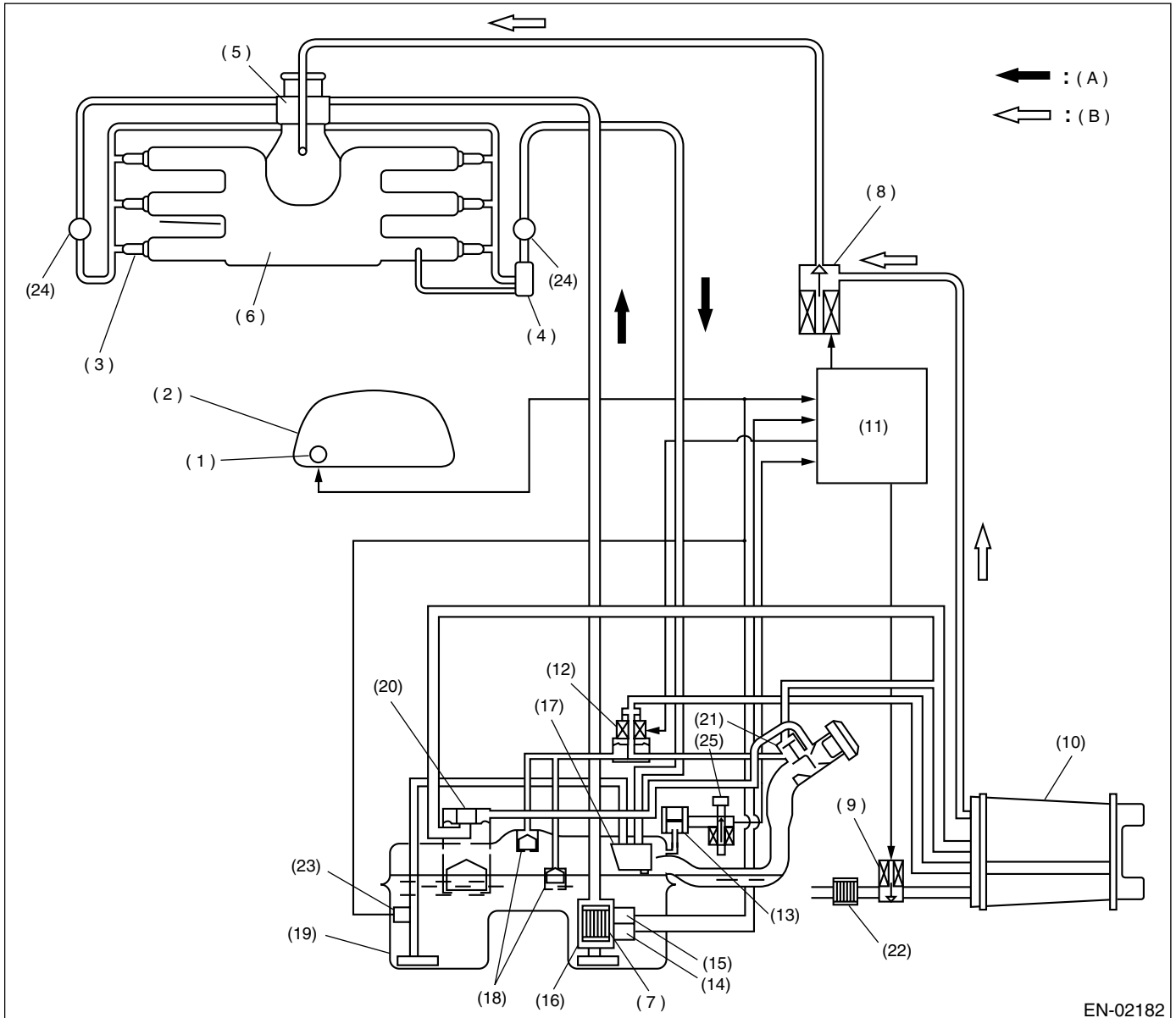

EN-02182

- |                                  |                                      |   |
|----------------------------------|--------------------------------------|---|
| (1) Fuel meter                   | (11) Engine control module (ECM)     | (21) Shut-off valve                         |
| (2) Combination meter            | (12) Pressure control solenoid valve | (22) Drain filter                           |
| (3) Fuel injector                | (13) Fuel tank pressure sensor       | (23) Fuel sub level sensor                  |
| (4) Pressure regulator           | (14) Fuel temperature sensor         | (24) Fuel damper                            |
| (5) Throttle body                | (15) Fuel level sensor               | (25) Tank pressure switching solenoid valve |
| (6) Intake manifold              | (16) Fuel pump                       | (A) Fuel line                               |
| (7) Fuel filter                  | (17) Jet pump                        | (B) Evaporation line                        |
| (8) Purge control solenoid valve | (18) Fuel cut valve                  |   |
| (9) Drain valve                  | (19) Fuel tank                       |   |
| (10) Canister                    | (20) Vent valve                      |   |

# DIAGNOSTIC TROUBLE CODE (DTC) DETECTING CRITERIA

GENERAL DESCRIPTION

## • Diagnostic Method

Fuel system is diagnosed by comparing the target air fuel ratio calculated by ECM with the actual air fuel ratio measured by sensor.

## 2. ENABLE CONDITION

Secondary Parameters	Enable Conditions
A/F main learning system	In operation
Engine coolant temperature	75 ↔ 119 °C (167 ↔ 246°F)
Change of intake pressure every 0.5 engine rev.	< 1.9 kPa (14 mmHg, 0.55 inHg)
Learning value of EVAP conc. during purge	≤ 0.1
Cumulative time of canister purge after engine start	20 seconds or more
Continuous period after canister purge starting	10 seconds or more
Intake manifold absolute pressure	≤ Map 1

## 3. GENERAL DRIVING CYCLE

Perform the diagnosis continuously idling after warm-up or at a constant vehicle speed.

## 4. DIAGNOSTIC METHOD

### • Abnormality Judgment

Judge that the fuel system malfunction occurs when the time during completing the malfunction criteria below continues 30 seconds or more by comparing the diagnosed value (fsobd) with threshold value.

### • Judgment Value

Malfunction Criteria	Threshold Value
$fsobd = (sglmd - tglmda) + faf + flaf$ where, sglmd = measured lambda  tglmda = target lambda faf = main feedback compensation coefficient every 64 milliseconds flaf = main feedback learning compensation coefficient	$\leq fsobdR1$ See Map 4 fsobdR1 = rich side threshold value of fsobd

### • Map 4

Amount of air (g (oz)/s)	0 (0)	3.2 (0.113)	6.4 (0.226)	9.6 (0.339)	12.8 (0.451)	16 (0.564)	19.2 (0.677)
fsobdR1 (%)	-40	-40	-33.2	-26.5	-26.5	-26.5	26.5

**Time Needed for Diagnosis:** 10 seconds × 3 times

**Malfunction Indicator Light Illumination:** Illuminates when malfunction occurs in 2 continuous driving cycles.

### • Normality Judgment

Judge OK when the malfunction criteria below are continued for 10 seconds.

# DIAGNOSTIC TROUBLE CODE (DTC) DETECTING CRITERIA

## GENERAL DESCRIPTION

---

### • Judgment Value

Malfunction Criteria	Threshold Value
$fsobd = (sglmd - tglmda) + faf + flaf$	$\geq -20\%$

### 5. DTC CLEAR CONDITION

- When the OK idling cycle was completed 40 times in a row
- When "Clear Memory" was performed

### 6. MALFUNCTION INDICATOR LIGHT CLEAR CONDITION

- When OK with similar drive in 3 drive cycles.
- When "Clear Memory" was performed

### 7. FAIL SAFE

- Purge control solenoid valve control: Not allowed to purge.
- Heavy fuel judgment control: Not allowed to carry out the heavy judgment.

### 8. ECM OPERATING AT DTC SETTING

- Memorize the freeze frame data. (For test mode \$02)
- Memorize the diagnostic value and trouble standard value. (For test mode \$06)

# DIAGNOSTIC TROUBLE CODE (DTC) DETECTING CRITERIA

GENERAL DESCRIPTION

---

## **AH:DTC P0174 — SYSTEM TOO LEAN (BANK 2) —**

### NOTE:

For detecting condition, refer to DTC P0171. <Ref. to GD(H6DO)-72, DTC P0171 — SYSTEM TOO LEAN (BANK 1) —, Diagnostic Trouble Code (DTC) Detecting Criteria.>

## **AI: DTC P0175 — SYSTEM TOO RICH (BANK 2) —**

### NOTE:

For detecting condition, refer to DTC P0172. <Ref. to GD(H6DO)-76, DTC P0172 — SYSTEM TOO RICH (BANK 1) —, Diagnostic Trouble Code (DTC) Detecting Criteria.>

# DIAGNOSTIC TROUBLE CODE (DTC) DETECTING CRITERIA

## GENERAL DESCRIPTION

### AJ:DTC P0181 — FUEL TEMPERATURE SENSOR “A” CIRCUIT RANGE/PERFORMANCE —

#### 1. OUTLINE OF DIAGNOSIS

Detect the malfunction of fuel temperature sensor output property. Perform the diagnosis in two methods; namely, drift diagnosis and stuck diagnosis. Judge NG when either of them results in NG, and judge OK when both of them result in OK.

##### • Drift Diagnosis

Normally fuel temperature is lower than engine coolant temperature. When the fuel temperature becomes higher than the engine coolant temperature, the range is considered to be shifted, and make an NG judgment.

#### 2. COMPONENT DESCRIPTION

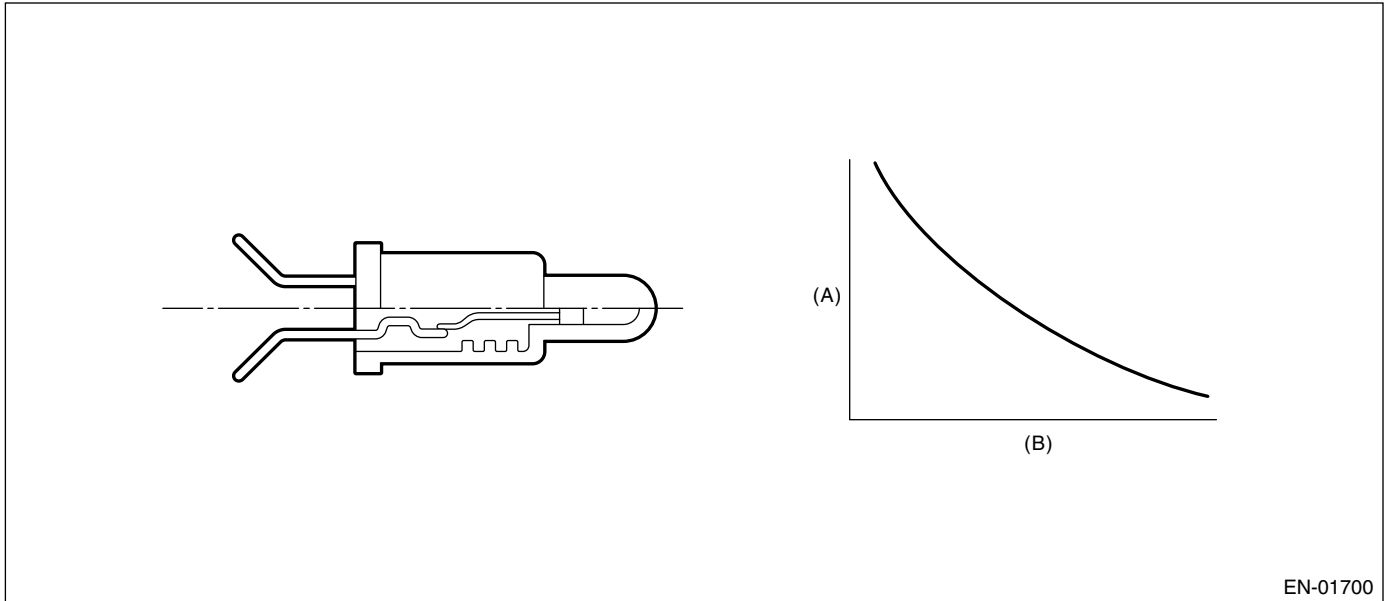

EN-01700

(A) Resistance ( $\Omega$ )

(B) Fuel temperature  $^{\circ}\text{C}$  ( $^{\circ}\text{F}$ )

#### 3. ENABLE CONDITION

Secondary Parameters	Enable Conditions
None	

#### 4. GENERAL DRIVING CYCLE

Always perform the diagnosis continuously.



# DIAGNOSTIC TROUBLE CODE (DTC) DETECTING CRITERIA

GENERAL DESCRIPTION

## 5. DIAGNOSTIC METHOD

### • Abnormality Judgment

Judge NG when the continuous time of completing the malfunction criteria below becomes more than 120 seconds.

### • Judgment Value

Malfunction Criteria	Threshold Value
Fuel level	$\geq 10 \ell$ (2.64 US gal, 2.20 Imp gal)
After engine starting	20 seconds or more
Engine coolant temperature – engine coolant temperature at engine starting	$> 10^{\circ}\text{C}$ (18°F)
Fuel temperature – engine coolant temperature	$\geq 10^{\circ}\text{C}$ (18°F)
Battery voltage	$> 10.9 \text{ V}$

**Time Needed for Diagnosis:** 120 seconds

**Malfunction Indicator Light Illumination:** Illuminates when malfunction occurs in 2 continuous driving cycles.

### • Normality Judgment

Judge OK when the malfunction criteria below are completed.

### • Judgment Value

Malfunction Criteria	Threshold Value
Fuel level	$\geq 10 \ell$ (2.64 US gal, 2.20 Imp gal)
After engine starting	20 seconds or more
Engine coolant temperature – engine coolant temperature at engine starting	$> 10^{\circ}\text{C}$ (18°F)
Fuel temperature – engine coolant temperature	$< 10^{\circ}\text{C}$ (18°F)
Battery voltage	$> 10.9 \text{ V}$

### • Stuck Diagnosis

If the fuel temperature which might rise along with the engine idling (the cumulative amount of intake air after engine starting is large) does not increase, the engine is considered to be stuck and make an NG judgment.

## 6. ENABLE CONDITION

Secondary Parameters	Enable Conditions
After engine starting	20 seconds or more
Battery voltage	$> 10.9 \text{ V}$

## 7. GENERAL DRIVING CYCLE

Always perform diagnosis continuously.

# DIAGNOSTIC TROUBLE CODE (DTC) DETECTING CRITERIA

## GENERAL DESCRIPTION

---

### 8. DIAGNOSTIC METHOD

- **Abnormality Judgment**

Judge NG when the malfunction criteria below are completed.

- **Judgment Value**

Malfunction Criteria	Threshold Value
Accumulated amount of intake air	$\geq 1100$ kg (2425 lb)
Fuel temperature difference between Max. and Min.	$< 3^{\circ}\text{C}$ (5.4 $^{\circ}\text{F}$ )

**Time Needed for Diagnosis:** To be determined.

**Malfunction Indicator Light Illumination:** Illuminates when malfunction occurs in 2 continuous driving cycles.

- **Normality Judgment**

Judge OK when the malfunction criteria below are completed.

- **Judgment Value**

Malfunction Criteria	Threshold Value
Accumulated amount of intake air	$\geq 1100$ kg (2425 lb)
Fuel temperature difference between Max. and Min.	$\geq 3^{\circ}\text{C}$ (5.4 $^{\circ}\text{F}$ )

### 9. DTC CLEAR CONDITION

- When the OK idling cycle was completed 40 times in a row
- When "Clear Memory" was performed

### 10.MALFUNCTION INDICATOR LIGHT CLEAR CONDITION

- When the OK driving cycle was completed 3 times in a row
- When "Clear Memory" was performed

### 11.FAIL SAFE

None

### 12.ECM OPERATING AT DTC SETTING

Memorize the freeze frame data. (For test mode \$02)

# DIAGNOSTIC TROUBLE CODE (DTC) DETECTING CRITERIA

GENERAL DESCRIPTION

---

MEMO:

# DIAGNOSTIC TROUBLE CODE (DTC) DETECTING CRITERIA

## GENERAL DESCRIPTION

### AK:DTC P0182 — FUEL TEMPERATURE SENSOR “A” CIRCUIT LOW INPUT —

#### 1. OUTLINE OF DIAGNOSIS

Detect the open or short circuit of fuel temperature sensor. Judge NG when out of the standard value.

#### 2. COMPONENT DESCRIPTION

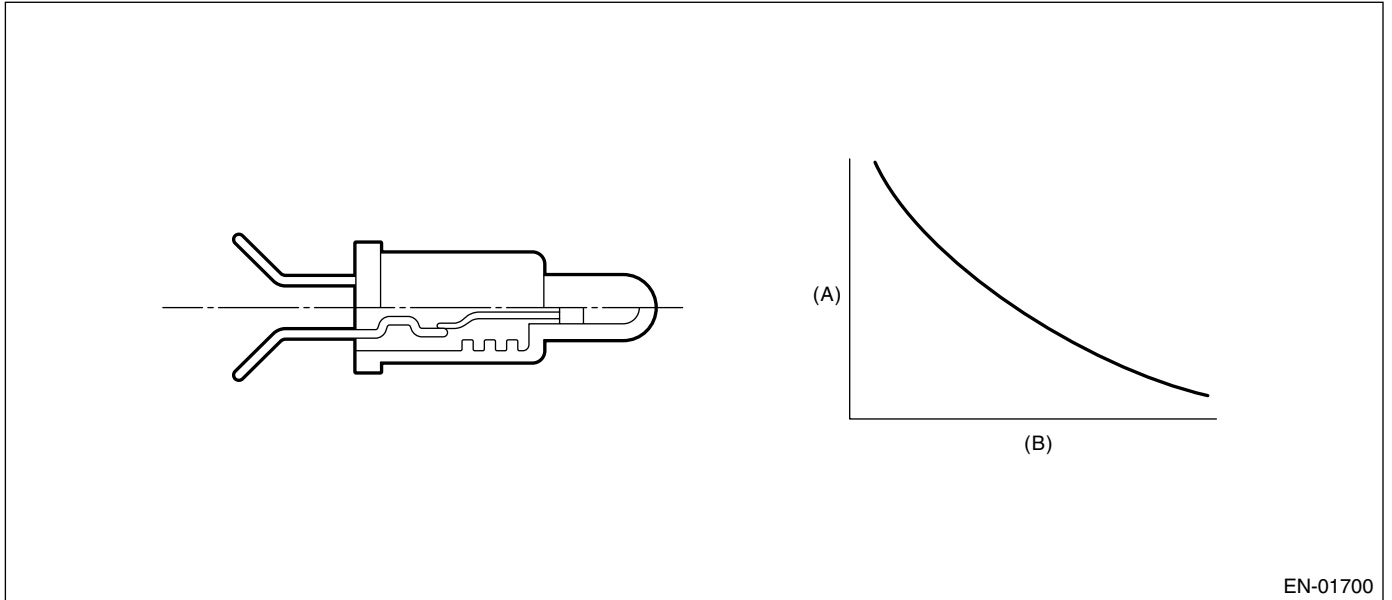

EN-01700

(A) Resistance (Ω)

(B) Fuel temperature °C (°F)

#### 3. ENABLE CONDITION

Secondary Parameters	Enable Conditions
None	

#### 4. GENERAL DRIVING CYCLE

Always perform the diagnosis continuously.

# DIAGNOSTIC TROUBLE CODE (DTC) DETECTING CRITERIA

GENERAL DESCRIPTION

## 5. DIAGNOSTIC METHOD

### • Abnormality Judgment

Judge NG when the continuous time of completing the malfunction criteria below becomes more than 2.5 seconds.

### • Judgment Value

Malfunction Criteria	Threshold Value
Output voltage	< 0.245 V
Battery voltage	≥ 10.9 V

**Time Needed for Diagnosis:** 2.5 seconds

**Malfunction Indicator Light Illumination:** Illuminates as soon as the malfunction occurs.

### • Normality Judgment

Judge OK when the cumulative time until completing the malfunction criteria below becomes more than 2.5 seconds.

### • Judgment Value

Malfunction Criteria	Threshold Value
Output voltage	≥ 0.245 V
Battery voltage	≥ 10.9 V

## 6. DTC CLEAR CONDITION

- When the OK idling cycle was completed 40 times in a row
- When "Clear Memory" was performed

## 7. MALFUNCTION INDICATOR LIGHT CLEAR CONDITION

- When the OK driving cycle was completed 3 times in a row
- When "Clear Memory" was performed

## 8. FAIL SAFE

None

## 9. ECM OPERATING AT DTC SETTING

Memorize the freeze frame data. (For test mode \$02)

# DIAGNOSTIC TROUBLE CODE (DTC) DETECTING CRITERIA

## GENERAL DESCRIPTION

### AL:DTC P0183 — FUEL TEMPERATURE SENSOR “A” CIRCUIT HIGH INPUT —

#### 1. OUTLINE OF DIAGNOSIS

Detect the open or short circuit of fuel temperature sensor. Judge NG when out of the standard value.

#### 2. COMPONENT DESCRIPTION

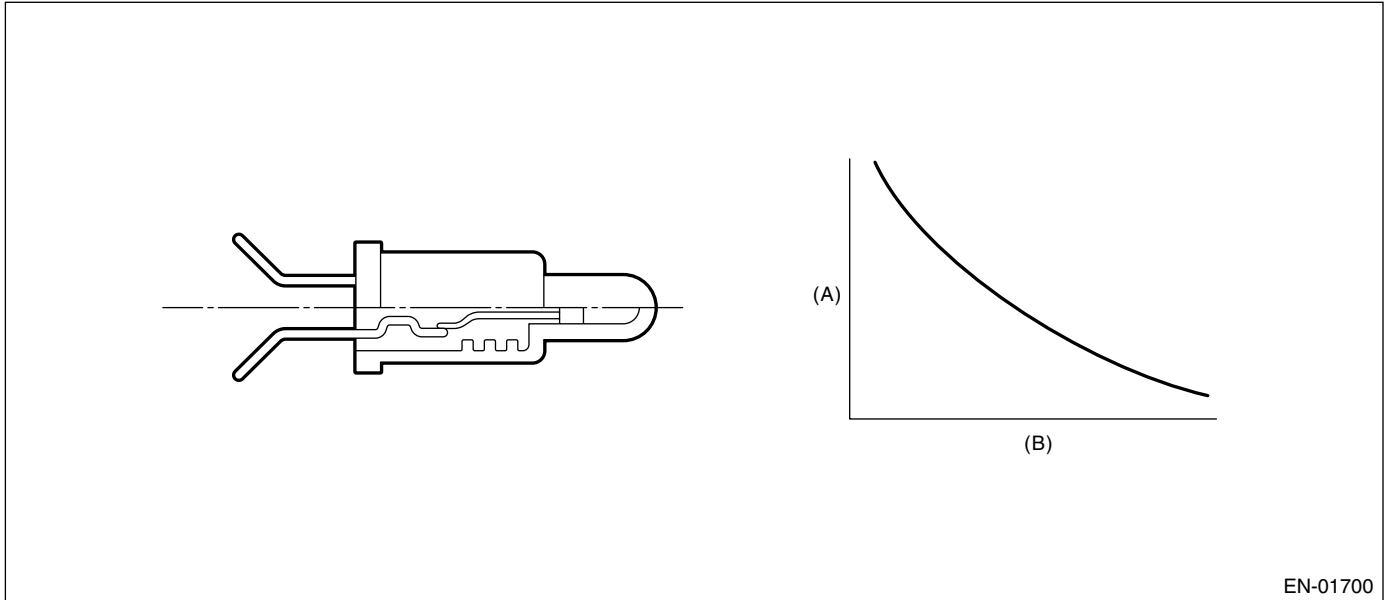

EN-01700

(A) Resistance (Ω)

(B) Fuel temperature °C (°F)

#### 3. ENABLE CONDITION

Secondary Parameters	Enable Conditions
None	

#### 4. GENERAL DRIVING CYCLE

Always perform the diagnosis continuously.

# DIAGNOSTIC TROUBLE CODE (DTC) DETECTING CRITERIA

GENERAL DESCRIPTION

## 5. DIAGNOSTIC METHOD

### • Abnormality Judgment

Judge NG when the continuous time of completing the malfunction criteria below becomes more than 2.5 seconds.

### • Judgment Value

Malfunction Criteria	Threshold Value
Output voltage	$\geq 4.72 \text{ V}$
Battery voltage	$\geq 10.9 \text{ V}$

**Time Needed for Diagnosis:** 2.5 seconds

**Malfunction Indicator Light Illumination:** Illuminates as soon as the malfunction occurs.

### • Normality Judgment

Judge OK when the cumulative time until completing the malfunction criteria below becomes more than 2.5 seconds.

### • Judgment Value

Malfunction Criteria	Threshold Value
Output voltage	$< 4.72 \text{ V}$
Battery voltage	$\geq 10.9 \text{ V}$

## 6. DTC CLEAR CONDITION

- When the OK idling cycle was completed 40 times in a row
- When "Clear Memory" was performed

## 7. MALFUNCTION INDICATOR LIGHT CLEAR CONDITION

- When the OK driving cycle was completed 3 times in a row
- When "Clear Memory" was performed

## 8. FAIL SAFE

None

## 9. ECM OPERATING AT DTC SETTING

Memorize the freeze frame data. (For test mode \$02)

# DIAGNOSTIC TROUBLE CODE (DTC) DETECTING CRITERIA

## GENERAL DESCRIPTION

### AM:DTC P0230 — FUEL PUMP PRIMARY CIRCUIT —

#### 1. OUTLINE OF DIAGNOSIS

Detect the malfunction of fuel pump control unit. Judge NG when the NG signal is sent through a diagnostic line coming from the fuel pump control unit. Fuel pump control unit detects the open or short circuit malfunction for each line, and then sends NG signals if one of them is found NG.

#### 2. COMPONENT DESCRIPTION

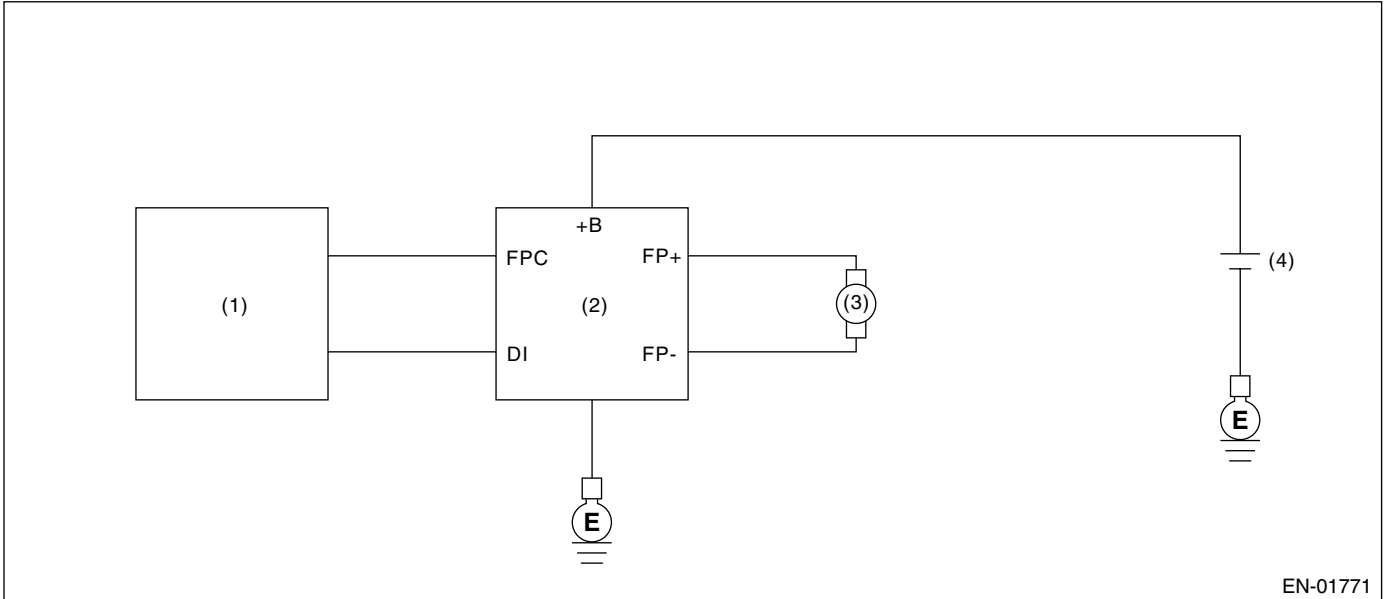

- (1) Engine control module (ECM)      (3) Fuel pump  
(2) Fuel pump control unit            (4) Battery

#### 3. ENABLE CONDITION

Secondary Parameters	Enable Conditions
None	

#### 4. GENERAL DRIVING CYCLE

Always perform the diagnosis continuously.



# DIAGNOSTIC TROUBLE CODE (DTC) DETECTING CRITERIA

GENERAL DESCRIPTION

## 5. DIAGNOSTIC METHOD

### • Abnormality Judgment

Judge NG when the continuous time of completing the malfunction criteria below becomes more than 2.5 seconds.

### • Judgment Value

Malfunction Criteria	Threshold Value
Battery voltage	$\geq 8\text{ V}$
After engine starting	30 seconds or more
Fuel pump control	ON
Fuel pump control unit output diagnosis signal	Low

**Time Needed for Diagnosis:** 2.5 seconds

**Malfunction Indicator Light Illumination:** Illuminates when malfunction occurs in 2 continuous driving cycles.

### • Normality Judgment

Judge OK and clear the NG when the malfunction criteria below are completed.

### • Judgment Value

Malfunction Criteria	Threshold Value
Battery voltage	$\geq 8\text{ V}$
After engine starting	30 seconds or more
Fuel pump control	ON
Fuel pump control unit output diagnosis signal	High

## 6. DTC CLEAR CONDITION

- When the OK idling cycle was completed 40 times in a row
- When "Clear Memory" was performed

## 7. MALFUNCTION INDICATOR LIGHT CLEAR CONDITION

- When the OK driving cycle was completed 3 times in a row
- When "Clear Memory" was performed

## 8. FAIL SAFE

OFF setting may be needed depending on the NG portion.

## 9. ECM OPERATING AT DTC SETTING

Memorize the freeze frame data. (For test mode \$02)

# DIAGNOSTIC TROUBLE CODE (DTC) DETECTING CRITERIA

## GENERAL DESCRIPTION

### AN:DTC P0301 — CYLINDER 1 MISFIRE DETECTED —

#### 1. OUTLINE OF DIAGNOSIS

Detect whether the misfire occurred or not. (Revolution fluctuation method) Monitoring the misfire which influences exhaust deterioration (1.5 times of FTP) and catalyst damage is made obligatory by the law. Misfire affecting these two has three patterns below.

- Intermittent misfire (The same cylinder misfires in random, or different cylinders misfire in random.): FTP 1.5 times misfire
- Every time misfire (The same cylinder misfires every time.): FTP 1.5 times misfire, Catalyst damage misfire

The following detecting methods are adopted for these detection.

- 1) Intermittent misfire: FTP 1.5 times misfire
  - 120° Interval Difference Method
  - 360° Interval Difference Method (whole range)
  - 720° Interval Difference Method (3,000 rpm or less)
- 2) Every time misfire: FTP 1.5 times misfire, Catalyst damage misfire
  - 360° Interval Difference Method

#### 2. ENABLE CONDITION

Secondary Parameters	Enable Conditions
Enable conditions of all secondary parameters	1 second or more
Intake manifold pressure change during 120°CA	< 4.56 kPa (34.18 mmHg, 1.346 inHg)
Engine speed change	< 500 rpm / 32 milliseconds
Throttle position change during 16 milliseconds	< 3.073°
Fuel shut-off function	Not operating
Fuel level	≥ 9.6 ℓ (2.54 US gal, 2.11 Imp gal)
Vehicle dynamic control or AT torque control	Not operating
Air condition	Not switching ON ←→ OFF
Radiator fan	Not switching ON ←→ OFF
Power steering switch	Not switching ON ←→ OFF
Starter	ON or OFF or change from ON to OFF
Evaporative system leak check	Not in operation
Engine speed	400 — 6500 rpm
Intake manifold pressure	> Map 3 or more
Battery voltage	≥ 8 V
Atmospheric pressure	≥ 75.0 kPa (563 mmHg, 22.17 inHg)
Decided fuel parameters	Do not allow ultra low evaporation

#### Map3

rpm	700	1000	1500	2000	2500	3000	3500	4000	4500	5000	5500	6000	6500
kPa	30.3	24.3	23.1	23.9	22.8	25.7	28.4	31.1	33.7	36.4	39.2	41.9	44.5
(mmHg, inHg)	(227, 8.94)	(182, 7.17)	(173.0, 6.81)	(179, 7.05)	(171, 6.73)	(193, 7.60)	(213, 8.39)	(233, 9.17)	(253, 9.96)	(273, 10.75)	(294, 11.57)	(314, 12.36)	(334, 13.15)

# DIAGNOSTIC TROUBLE CODE (DTC) DETECTING CRITERIA

GENERAL DESCRIPTION

## 3. GENERAL DRIVING CYCLE

- The misfire is detected from idling to high engine revolution speed if the condition is matched.
- Perform the diagnosis continuously.

## 4. DIAGNOSTIC METHOD

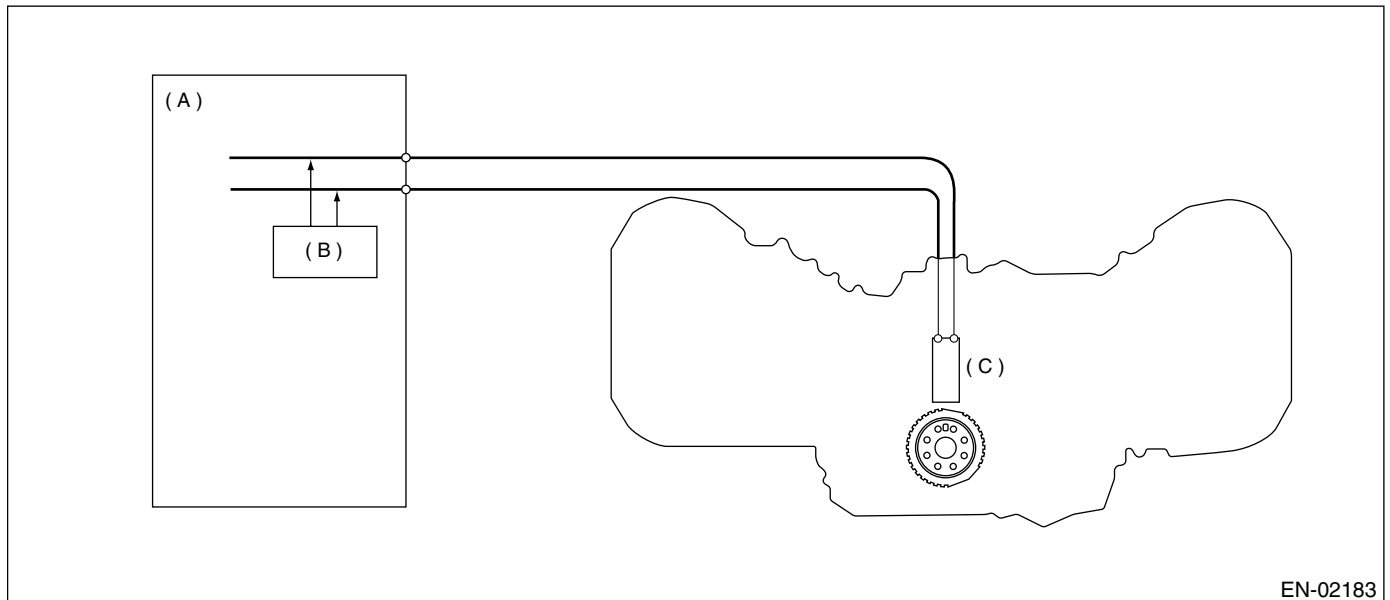

EN-02183

(A) Engine control module (ECM)

(B) Diagnosis circuit

(C) Crankshaft position sensor

When the misfire occurred, the engine speed is decreased and the crankshaft position speed will change. Calculate the interval difference value (diagnostic value) from crankshaft position speed by the following formula, and judge whether the misfire occurs or not comparing the calculated result with judgment value. Counting the number of misfire up, and if the misfire ratio is higher during 1000 rev. or 200 rev., judge NG for the corresponding cylinder.

# DIAGNOSTIC TROUBLE CODE (DTC) DETECTING CRITERIA

## GENERAL DESCRIPTION

Calculate the diagnostic value (from crankshaft position speed)

- Misfire detection every single ignition (Compare diagnostic value with judgment value)
- 120° Interval Difference Method
  - 360° Interval Difference Method
  - 720° Interval Difference Method

- NG judgment (Judge misfire occurrence required by the law) (Compare number of misfire with judgment)
- FTP1.5 times misfire NG judgment
  - Catalyst damage misfire NG judgment

As the following figure, pick out a random cylinder as the standard and name it omg 0. And the former crankshaft position speed is named omg 1, the second former crankshaft position speed is named omg 2, the third is named omg 3, and the following is the same.

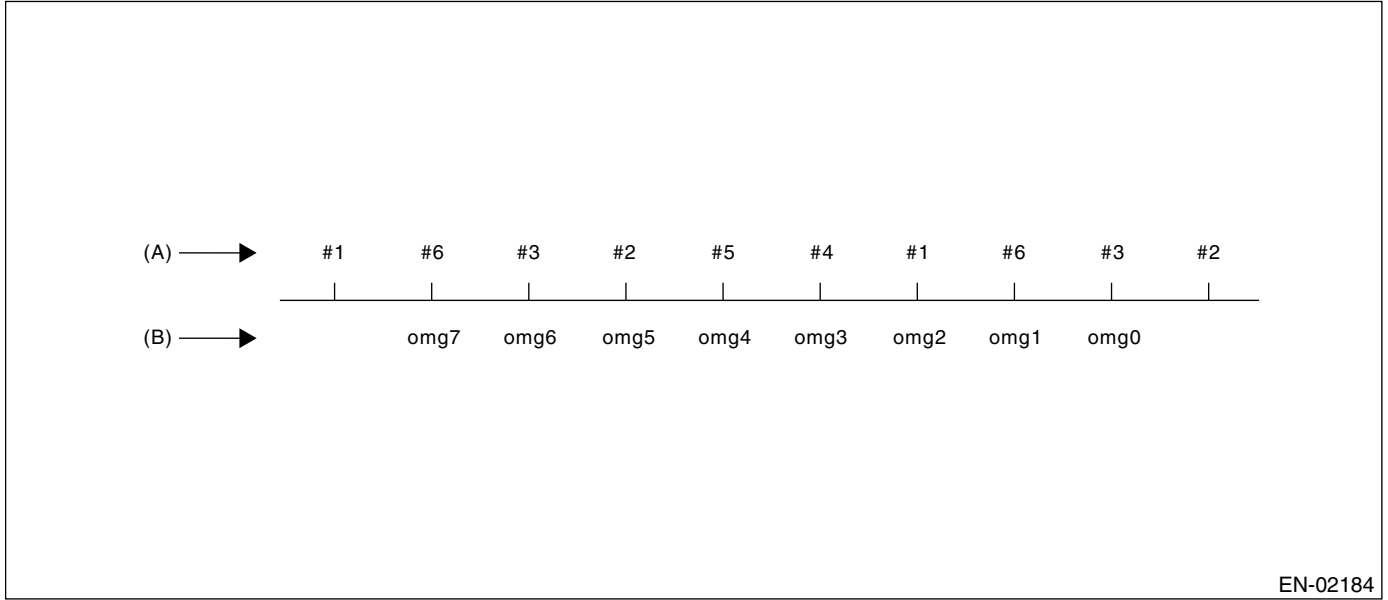

EN-02184

(A) Ignition order

(B) Crankshaft position speed

# DIAGNOSTIC TROUBLE CODE (DTC) DETECTING CRITERIA

GENERAL DESCRIPTION

## • 120° Interval Difference Method

Diagnosis value  $domg120 = (omg -1 - omg 0) - (omg 7 - omg 1)/6$

Judge misfire occurs in the following cases.

- $domg 120 >$  judgment value of positive side
- $domg 121 \leq$  judgment value of negative side  
(judgment value before 120°CA)

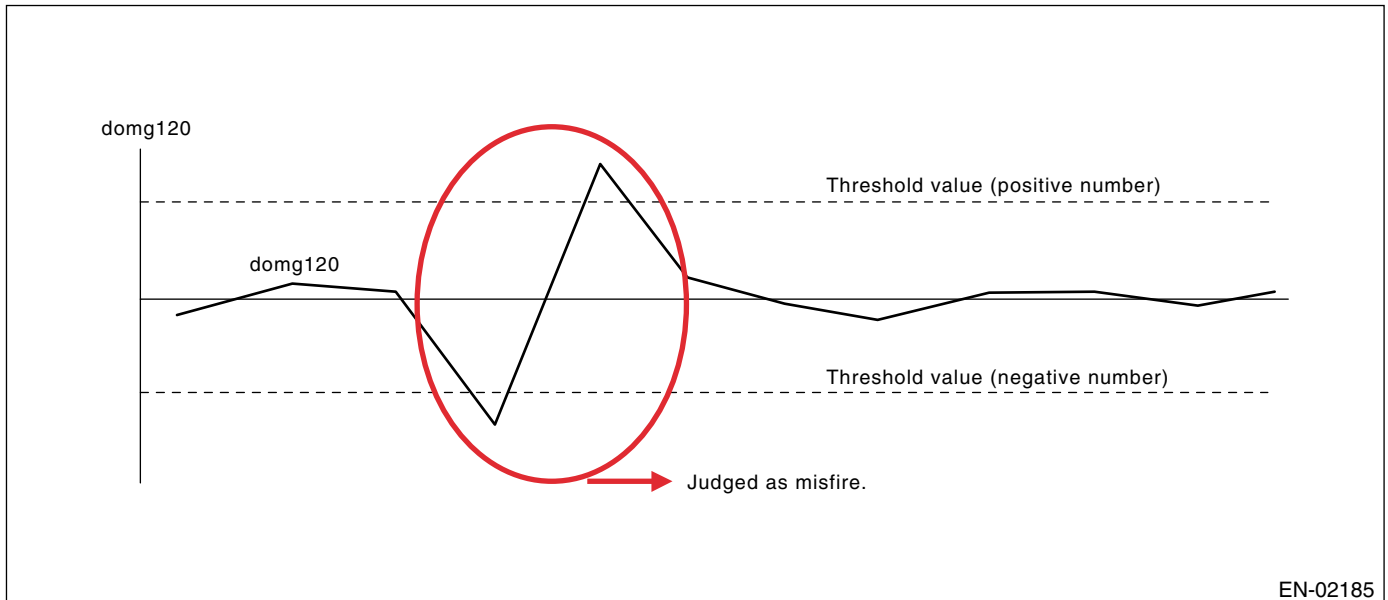

## • 360° Interval Difference Method

Diagnosis value  $domg 360 = (omg 1 - omg 0) - (omg 4 - omg 3)$

Misfire judgment  $domg 360 >$  judgment value  $\rightarrow$  Misfire occurs

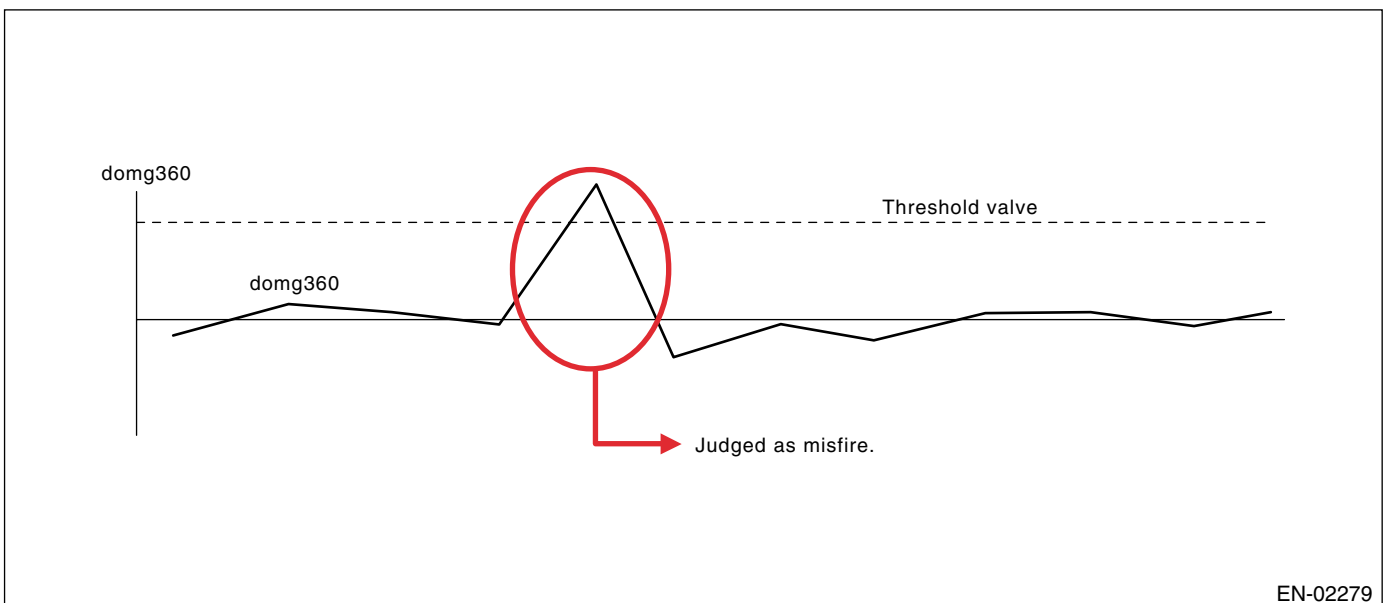

# DIAGNOSTIC TROUBLE CODE (DTC) DETECTING CRITERIA

## GENERAL DESCRIPTION

### • 720° Interval Difference Method

Diagnosis value  $\text{domg } 720 = (\text{omg } 1 - \text{omg } 0) - (\text{omg } 7 - \text{omg } 6)$

Misfire judgment  $\text{domg } 720 > \text{judgment value} \rightarrow \text{Misfire occurs}$

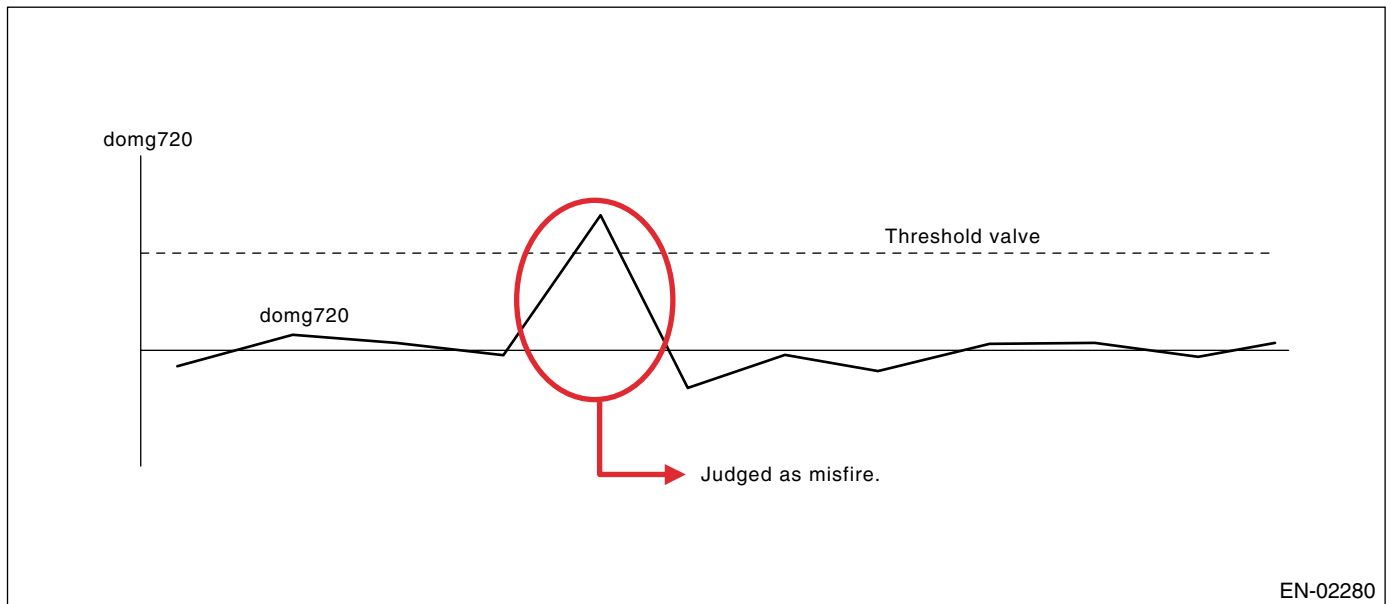

• FTP 1.5 times misfire (Misfire occurrence level affecting exhaust gas)

• Judgment Value (Judge that malfunction occurs when the misfire ratio is high in 1000 engine revs.)

Malfunction Criteria	Threshold Value
FTP emission judgment value	> 1.0% in 1000 revs.

**Time Needed for Diagnosis:** 1000 engine revs.

**Malfunction Indicator Light Illumination:** Illuminates when malfunction occurs in 2 continuous driving cycles.

# DIAGNOSTIC TROUBLE CODE (DTC) DETECTING CRITERIA

GENERAL DESCRIPTION

- Catalyst damage misfire (Misfire occurrence level damaging catalyst)
- Judgment Value (Judge that malfunction occurs when the misfire ratio is high in 200 engine revs. (600 ignitions))

Malfunction Criteria	Threshold Value
Catalyst damage misfire judgment value	See Map 1

**Map 1 Fault criteria threshold for misfire which would result in catalyst damage**

dEngine speed (rpm)	700	15	15	15	15	15	15	15	15
	1000	15	15	15	15	15	15	15	15
	1500	15	14.17	12.5	12.5	14.17	13.83	13.83	13.83
	2000	12.5	15	15	14.17	13.5	12	8	8.333
	2500	11.67	11.67	10.5	8.333	8.333	8.167	4.5	8.333
	3000	10	8.333	8.333	7.833	8.333	8.333	3.833	5.833
	3500	8.333	8.333	8.333	7.167	7.833	6.333	6.333	6.333
	4000	6.833	5.5	3.833	2.833	2	4.167	5	5
	4500	5	5	3.833	3.167	3.833	4.167	3.833	4.5
	5000	5	4.5	2	2.667	3.333	3.5	3.833	3.833
	5500	4.167	3.833	2	2	2	2	2	2
	6000	4.167	3.833	2	2	2	2	2	2
	6500	4.167	2.5	2	2.167	2	2	3	3.167
		28.17 (211.33, 8.32)	38.58 (289.45, 11.396)	49.00 (367.58, 14.47)	59.41 (445.7, 17.55)	69.83 (523.83, 20.623)	80.24 (601.95, 23.699)	90.65 (680.08, 26.775)	101.07 (758.2, 29.85)
Intake manifold pressure kPa (mmHg, inHg)									

EN-02186

These figures mean the misfire ratio (%) in 600 ignitions; for example, 15 (%) means 600 (ignition) × 15 (%) = 90 (ignition) or more, so this case is judged misfire.

**Time Needed for Diagnosis:** 200 engine revs.

**Malfunction Indicator Light Illumination:** Illuminates as soon as the malfunction occurs.

## 5. DTC CLEAR CONDITION

- When the OK idling cycle was completed 40 times in a row
- When "Clear Memory" was performed

## 6. MALFUNCTION INDICATOR LIGHT CLEAR CONDITION

- When the OK driving cycle was completed 3 times in a row
- When "Clear Memory" was performed

## 7. FAIL SAFE

None

## 8. ECM OPERATING AT DTC SETTING

Memorize the freeze frame data. (For test mode \$02)

# DIAGNOSTIC TROUBLE CODE (DTC) DETECTING CRITERIA

## GENERAL DESCRIPTION

---

### **AO:DTC P0302 — CYLINDER 2 MISFIRE DETECTED —**

**NOTE:**

For the diagnostic procedure, refer to DTC P0301. <Ref. to GD(H6DO)-90, DTC P0301 — CYLINDER 1 MISFIRE DETECTED —, Diagnostic Trouble Code (DTC) Detecting Criteria.>

### **AP:DTC P0303 — CYLINDER 3 MISFIRE DETECTED —**

**NOTE:**

For the diagnostic procedure, refer to DTC P0301. <Ref. to GD(H6DO)-90, DTC P0301 — CYLINDER 1 MISFIRE DETECTED —, Diagnostic Trouble Code (DTC) Detecting Criteria.>

### **AQ:DTC P0304 — CYLINDER 4 MISFIRE DETECTED —**

**NOTE:**

For the diagnostic procedure, refer to DTC P0301. <Ref. to GD(H6DO)-90, DTC P0301 — CYLINDER 1 MISFIRE DETECTED —, Diagnostic Trouble Code (DTC) Detecting Criteria.>

### **AR:DTC P0305 — CYLINDER 5 MISFIRE DETECTED —**

**NOTE:**

For detecting condition, refer to DTC P0301. <Ref. to GD(H6DO)-90, DTC P0301 — CYLINDER 1 MISFIRE DETECTED —, Diagnostic Trouble Code (DTC) Detecting Criteria.>

### **AS:DTC P0306 — CYLINDER 6 MISFIRE DETECTED —**

**NOTE:**

For detecting condition, refer to DTC P0301. <Ref. to GD(H6DO)-90, DTC P0301 — CYLINDER 1 MISFIRE DETECTED —, Diagnostic Trouble Code (DTC) Detecting Criteria.>



# DIAGNOSTIC TROUBLE CODE (DTC) DETECTING CRITERIA

GENERAL DESCRIPTION

---

MEMO:

# DIAGNOSTIC TROUBLE CODE (DTC) DETECTING CRITERIA

## GENERAL DESCRIPTION

### AT:DTC P0327 — KNOCK SENSOR 1 CIRCUIT LOW INPUT (BANK 1 OR SINGLE SENSOR) —

#### 1. OUTLINE OF DIAGNOSIS

Detect the open or short circuit of the knock sensor. Judge NG when out of the standard value.

#### 2. COMPONENT DESCRIPTION

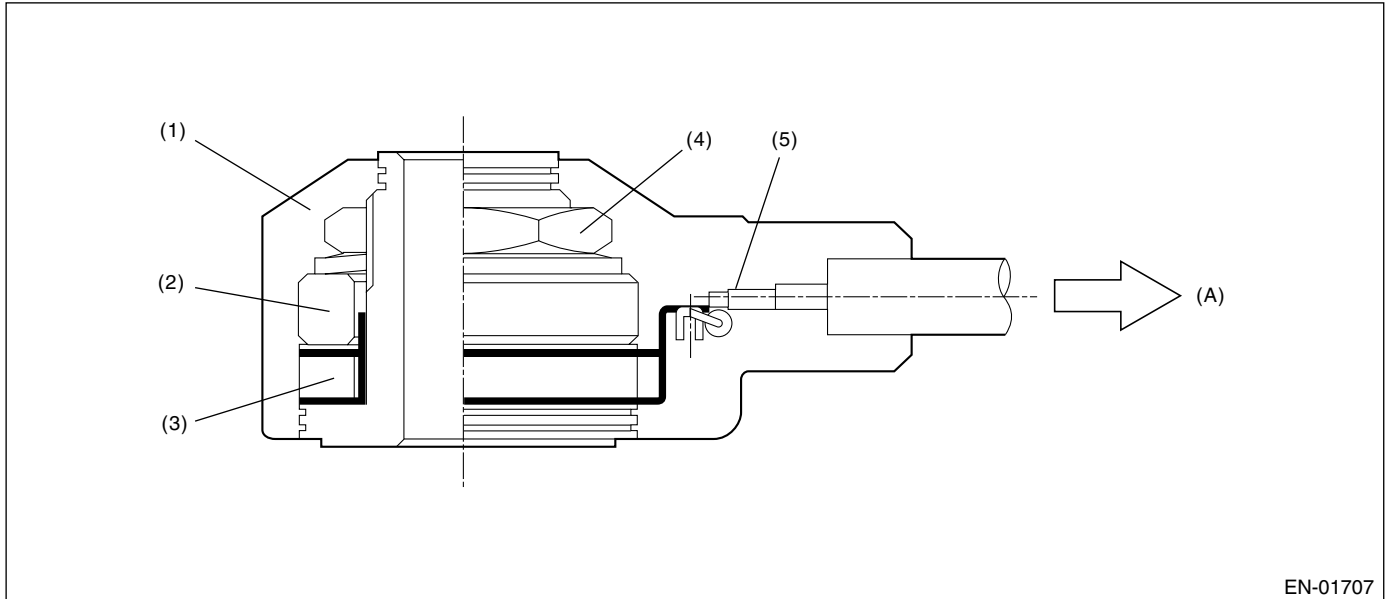

- (1) Case
- (2) Weight
- (3) Piezoelectric element

- (4) Nut
- (5) Resistance

- (A) To knock sensor harness

#### 3. ENABLE CONDITION

Secondary Parameters	Enable Conditions
None	

#### 4. GENERAL DRIVING CYCLE

Always perform the diagnosis continuously.

# DIAGNOSTIC TROUBLE CODE (DTC) DETECTING CRITERIA

GENERAL DESCRIPTION

## 5. DIAGNOSTIC METHOD

### • Abnormality Judgment

Judge NG when the continuous time of completing the malfunction criteria below becomes more than 1 second.

### • Judgment Value

Malfunction Criteria	Threshold Value
Output voltage	< 0.2 V
Ignition switch	ON

**Time Needed for Diagnosis:** 1 second

**Malfunction Indicator Light Illumination:** Illuminates as soon as the malfunction occurs.

### • Normality Judgment

Judge OK and clear NG when the malfunction criteria below are completed.

### • Judgment Value

Malfunction Criteria	Threshold Value
Output voltage	$\geq 0.2$ V
Ignition switch	ON

## 6. DTC CLEAR CONDITION

- When the OK idling cycle was completed 40 times in a row
- When "Clear Memory" was performed

## 7. MALFUNCTION INDICATOR LIGHT CLEAR CONDITION

- When the OK driving cycle was completed 3 times in a row
- When "Clear Memory" was performed

## 8. FAIL SAFE

- Knocking compensation

At normal condition: Self-learning ignition advance value = knock F/B advance + overall self-learning advance value + partial self-learning advance value

When malfunctioning: Self-learning ignition advance value =  $-6^{\circ}\text{CA}$  ( $6^{\circ}\text{CA}$  retard)

knock F/B advance value =  $0^{\circ}\text{CA}$

Prohibit overall self-learning

Partially prohibit self-learning

## 9. ECM OPERATING AT DTC SETTING

Memorize the freeze frame data. (For test mode \$02)

# DIAGNOSTIC TROUBLE CODE (DTC) DETECTING CRITERIA

## GENERAL DESCRIPTION

### AU:DTC P0328 — KNOCK SENSOR 1 CIRCUIT HIGH INPUT (BANK 1 OR SINGLE SENSOR) —

#### 1. OUTLINE OF DIAGNOSIS

Detect the open or short circuit of the knock sensor. Judge NG when out of the standard value.

#### 2. COMPONENT DESCRIPTION

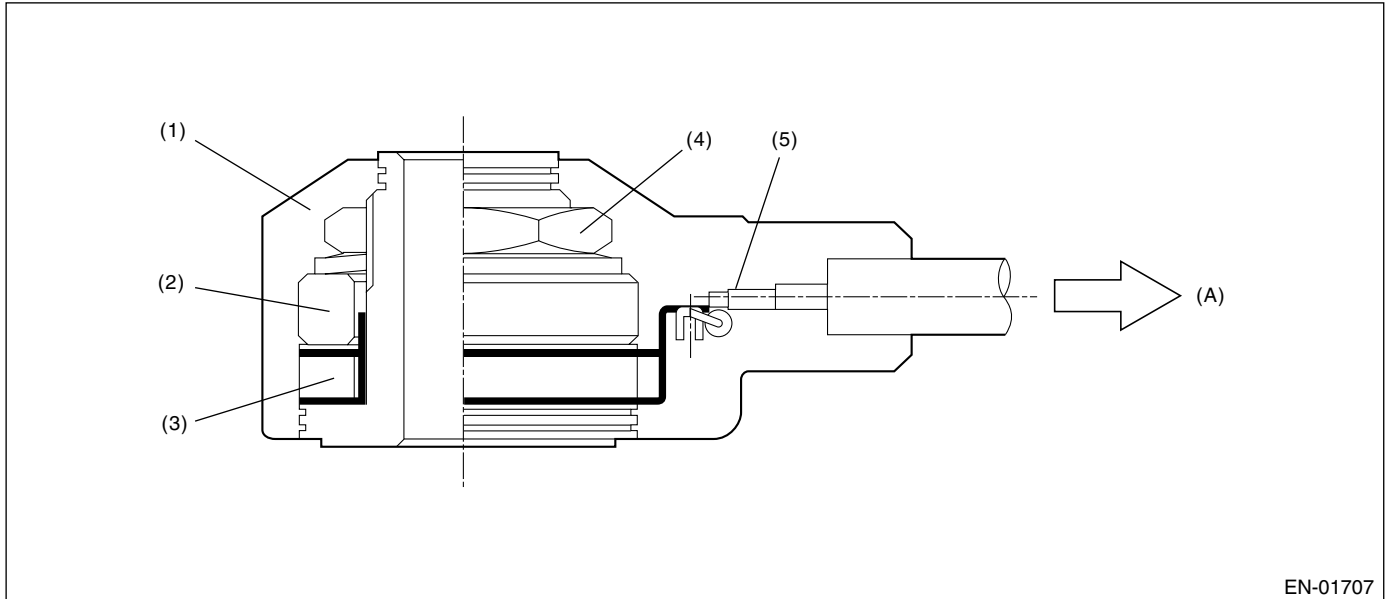

- (1) Case
- (2) Weight
- (3) Piezoelectric element

- (4) Nut
- (5) Resistance

- (A) To knock sensor harness

#### 3. ENABLE CONDITION

Secondary Parameters	Enable Conditions
None	

#### 4. GENERAL DRIVING CYCLE

Always perform diagnosis continuously.

# DIAGNOSTIC TROUBLE CODE (DTC) DETECTING CRITERIA

GENERAL DESCRIPTION

## 5. DIAGNOSTIC METHOD

### • Abnormality Judgment

Judge NG when the continuous time of completing the malfunction criteria below becomes more than 1 second.

### • Judgment Value

Malfunction Criteria	Threshold Value
Output voltage	$\geq 4.8 \text{ V}$
Ignition switch	ON

**Time Needed for Diagnosis:** 1 second

**Malfunction Indicator Light Illumination:** Illuminates as soon as the malfunction occurs.

### • Normality Judgment

Judge OK and clear NG when the malfunction criteria below are completed.

### • Judgment Value

Malfunction Criteria	Threshold Value
Output voltage	$< 4.8 \text{ V}$
Ignition switch	ON

## 6. DTC CLEAR CONDITION

- When the OK idling cycle was completed 40 times in a row
- When "Clear Memory" was performed

## 7. MALFUNCTION INDICATOR LIGHT CLEAR CONDITION

- When the OK driving cycle was completed 3 times in a row
- When "Clear Memory" was performed

## 8. FAIL SAFE

- Knocking compensation

At normal condition: Self-learning ignition advance value = knock F/B advance + overall self-learning advance value + partial self-learning advance value

When malfunctioning: Self-learning ignition advance value =  $-6^{\circ}\text{CA}$  ( $6^{\circ}\text{CA}$  retard)

knock F/B advance value =  $0^{\circ}\text{CA}$

Prohibit overall self-learning

Partially prohibit self-learning

## 9. ECM OPERATING AT DTC SETTING

Memorize the freeze frame data. (For test mode \$02)

## DIAGNOSTIC TROUBLE CODE (DTC) DETECTING CRITERIA

### GENERAL DESCRIPTION

---

#### **AV:DTC P0332 — KNOCK SENSOR 2 CIRCUIT LOW INPUT (BANK 2) —**

**NOTE:**

For the detection standard, refer to P0327. <Ref. to GD(H6DO)-98, DTC P0327 — KNOCK SENSOR 1 CIRCUIT LOW INPUT (BANK 1 OR SINGLE SENSOR) —, Diagnostic Trouble Code (DTC) Detecting Criteria.>

#### **AW:DTC P0333 — KNOCK SENSOR 2 CIRCUIT HIGH INPUT (BANK 2) —**

**NOTE:**

For the detection standard, refer to P0328. <Ref. to GD(H6DO)-100, DTC P0328 — KNOCK SENSOR 1 CIRCUIT HIGH INPUT (BANK 1 OR SINGLE SENSOR) —, Diagnostic Trouble Code (DTC) Detecting Criteria.>

**DIAGNOSTIC TROUBLE CODE (DTC) DETECTING CRITERIA**

GENERAL DESCRIPTION

---

**MEMO:**

# DIAGNOSTIC TROUBLE CODE (DTC) DETECTING CRITERIA

## GENERAL DESCRIPTION

### AX:DTC P0335 — CRANKSHAFT POSITION SENSOR “A” CIRCUIT —

#### 1. OUTLINE OF DIAGNOSIS

Detect the open or short circuit of crankshaft position sensor. Judge NG when the crankshaft signal does not input regardless of turning the starter.

#### 2. COMPONENT DESCRIPTION

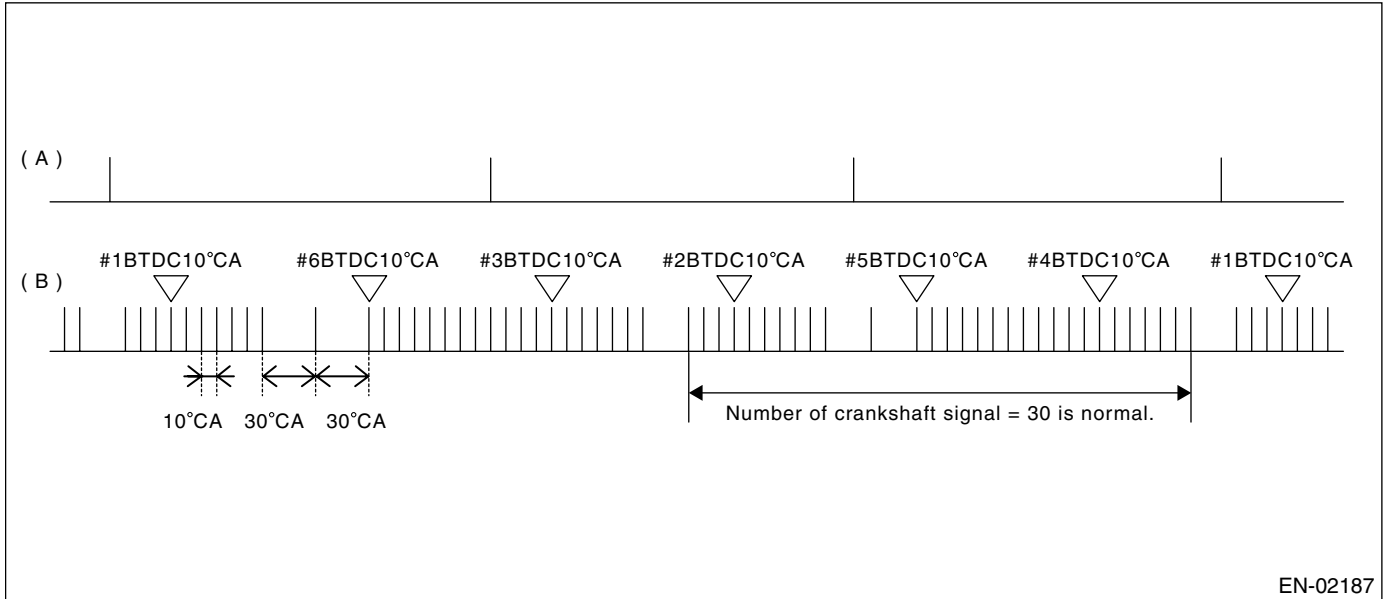

(A) Camshaft signal

(B) Crankshaft signal

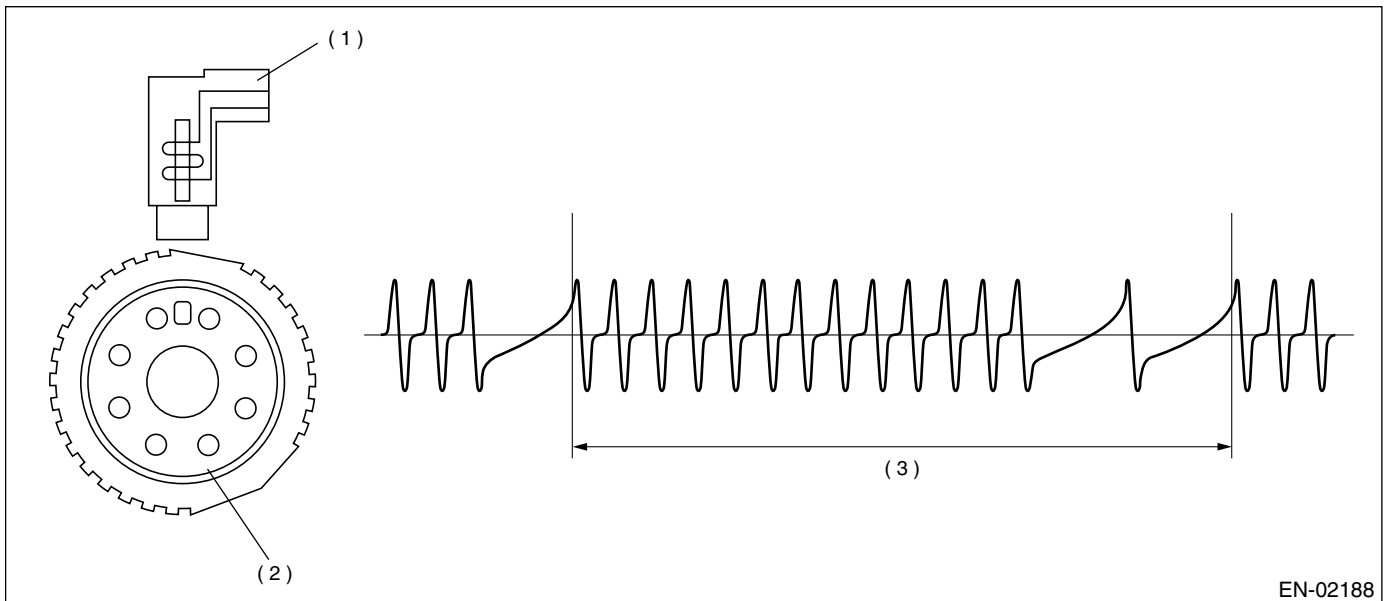

(1) Crankshaft position sensor

(2) Crankshaft sprocket

(3) Crankshaft half-turn

#### 3. ENABLE CONDITION

Secondary Parameters	Enable Conditions
None	



# DIAGNOSTIC TROUBLE CODE (DTC) DETECTING CRITERIA

GENERAL DESCRIPTION

## 4. GENERAL DRIVING CYCLE

Always perform the diagnosis continuously.

## 5. DIAGNOSTIC METHOD

### • Abnormality Judgment

Judge NG when the continuous time of completing the malfunction criteria below becomes more than 3 seconds.

### • Judgment Value

Malfunction Criteria	Threshold Value
Starter switch	ON
Crankshaft position sensor signal	Not detected
Battery voltage	$\geq 8$ V

**Time Needed for Diagnosis:** 3 seconds

**Malfunction Indicator Light Illumination:** Illuminates as soon as the malfunction occurs.

### • Normality Judgment

Judge OK when the continuous time of completing the malfunction criteria below becomes more than 3 seconds.

### • Judgment Value

Malfunction Criteria	Threshold Value
Crankshaft position sensor signal	Input exists
Battery voltage	$\geq 8$ V

## 6. DTC CLEAR CONDITION

- When the OK idling cycle was completed 40 times in a row
- When "Clear Memory" was performed

## 7. MALFUNCTION INDICATOR LIGHT CLEAR CONDITION

- When the OK driving cycle was completed 3 times in a row
- When "Clear Memory" was performed

## 8. FAIL SAFE

None

## 9. ECM OPERATING AT DTC SETTING

Memorize the freeze frame data. (For test mode \$02)

# DIAGNOSTIC TROUBLE CODE (DTC) DETECTING CRITERIA

## GENERAL DESCRIPTION

### AY:DTC P0336 — CRANKSHAFT POSITION SENSOR “A” CIRCUIT RANGE/ PERFORMANCE —

#### 1. OUTLINE OF DIAGNOSIS

Detect the malfunction of crankshaft position sensor output property. Judge NG when the number of crankshaft signal every 1 revolution becomes abnormal.

#### 2. COMPONENT DESCRIPTION

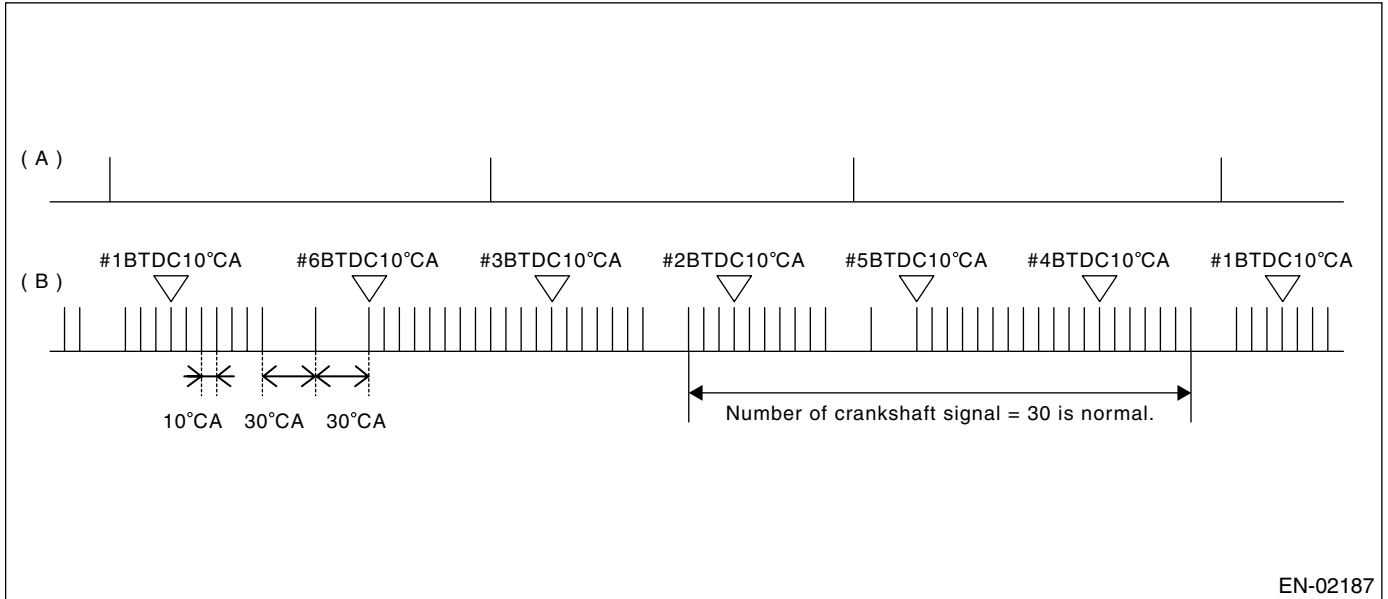

(A) Camshaft signal

(B) Crankshaft signal

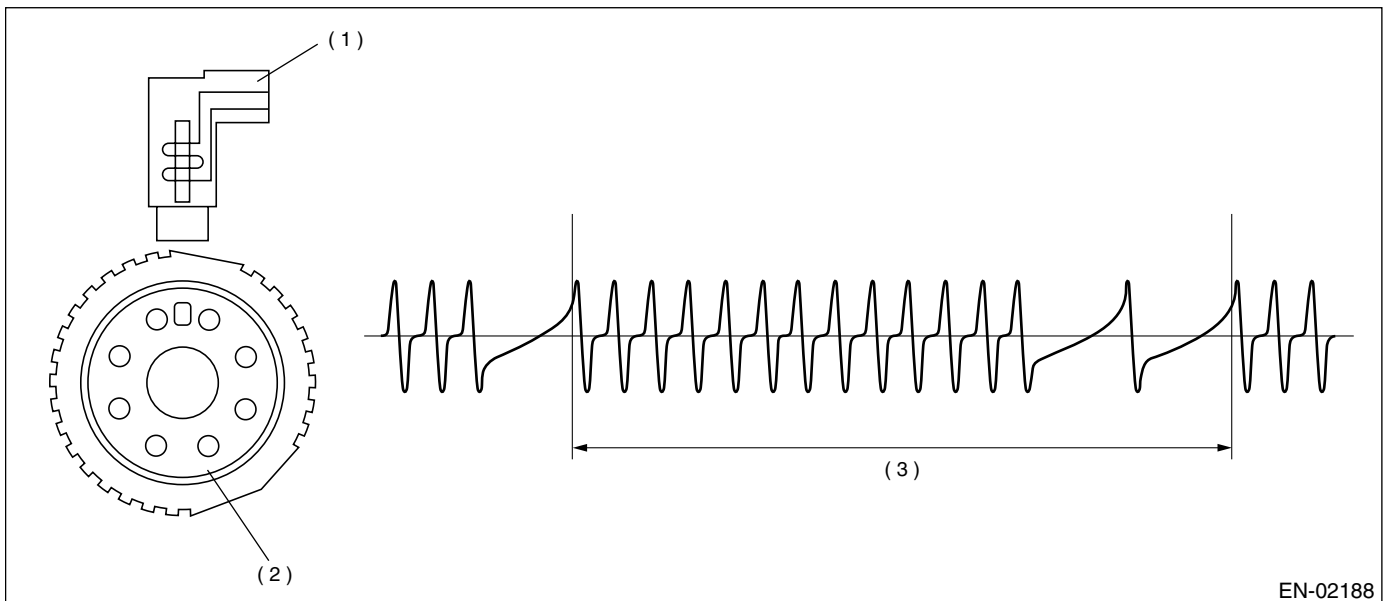

(1) Crankshaft position sensor

(2) Crankshaft sprocket

(3) Crankshaft half-turn

# DIAGNOSTIC TROUBLE CODE (DTC) DETECTING CRITERIA

GENERAL DESCRIPTION

## 3. ENABLE CONDITION

Secondary Parameters	Enable Conditions
Battery voltage	$\geq 8\text{ V}$
Engine speed	$< 3000\text{ rpm}$

## 4. GENERAL DRIVING CYCLE

Perform the diagnosis continuously under 3000 rpm engine speed.

## 5. DIAGNOSTIC METHOD

### • Abnormality Judgment

Judge NG when all the malfunction criteria below are completed more than 10 times in a row.

### • Judgment Value

Malfunction Criteria	Threshold Value
Cylinder number distinction	Completed
Amount of crank sensor signal during 1 rev.	Not = 30

**Time Needed for Diagnosis:** 10 engine revs.

**Malfunction Indicator Light Illumination:** Illuminates when malfunction occurs in 2 continuous driving cycles.

### • Normality Judgment

Judge OK and clear the NG when the malfunction criteria below are completed.

### • Judgment Value

Malfunction Criteria	Threshold Value
Cylinder number distinction	Completed
Amount of crank sensor signal during 1 rev.	= 30

## 6. DTC CLEAR CONDITION

- When the OK idling cycle was completed 40 times in a row
- When "Clear Memory" was performed

## 7. MALFUNCTION INDICATOR LIGHT CLEAR CONDITION

- When the OK driving cycle was completed 3 times in a row
- When "Clear Memory" was performed

## 8. FAIL SAFE

None

## 9. ECM OPERATING AT DTC SETTING

Memorize the freeze frame data. (For test mode \$02)

# DIAGNOSTIC TROUBLE CODE (DTC) DETECTING CRITERIA

## GENERAL DESCRIPTION

### AZ:DTC P0340 — CAMSHAFT POSITION SENSOR “A” CIRCUIT (BANK 1 OR SINGLE SENSOR) —

#### 1. OUTLINE OF DIAGNOSIS

Detect the open or short circuit of camshaft position sensor. Judge NG when the number of camshaft signal remains to be abnormal.

#### 2. COMPONENT DESCRIPTION

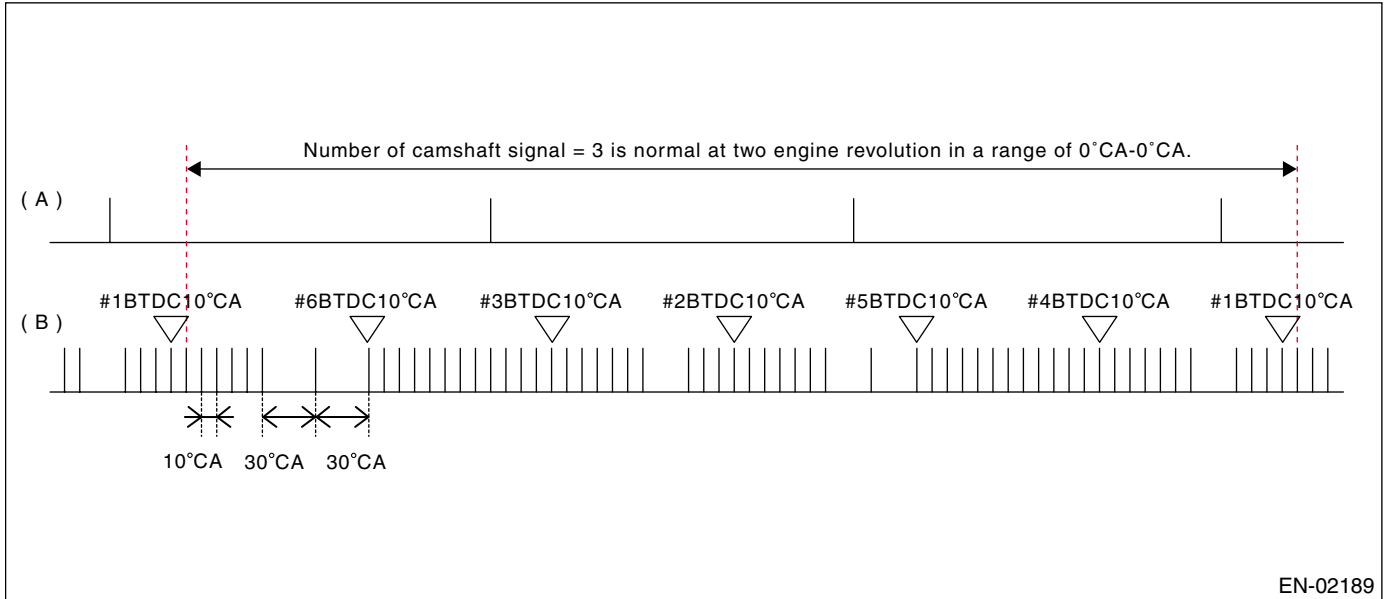

(A) Camshaft signal

(B) Crankshaft signal

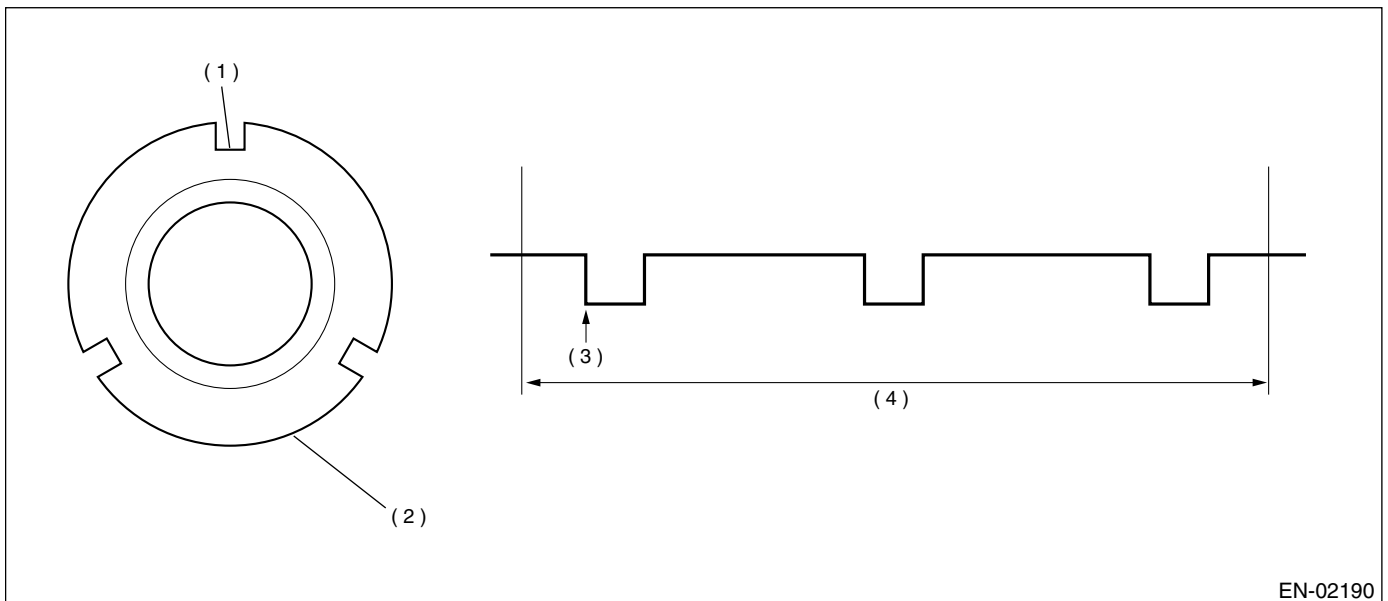

(1) Slot  
(2) Plate

(3) Sensing point

(4) Camshaft one revolution (Engine two revolutions)

# DIAGNOSTIC TROUBLE CODE (DTC) DETECTING CRITERIA

GENERAL DESCRIPTION

## 3. ENABLE CONDITION

Secondary Parameters	Enable Conditions
None	

## 4. GENERAL DRIVING CYCLE

Always perform the diagnosis continuously.

## 5. DIAGNOSTIC METHOD

### • Abnormality Judgment

Judge NG when the engine speed continues more than 8 revolutions.

### • Judgment Value

Malfunction Criteria	Threshold Value
Battery voltage	$\geq 8 \text{ V}$
Amount of camshaft sensor signal during 2 revs.	$\neq 3$

**Time Needed for Diagnosis:** 8 revs.

**Malfunction Indicator Light Illumination:** Illuminates as soon as the malfunction occurs.

### • Normality Judgment

Judge OK and clear the NG when the malfunction criteria below are completed.

### • Judgment Value

Malfunction Criteria	Threshold Value
Battery voltage	$\geq 8 \text{ V}$
Amount of camshaft sensor signal during 2 revs.	$= 3$

## 6. DTC CLEAR CONDITION

- When the OK idling cycle was completed 40 times in a row
- When "Clear Memory" was performed

## 7. MALFUNCTION INDICATOR LIGHT CLEAR CONDITION

- When the OK driving cycle was completed 3 times in a row
- When "Clear Memory" was performed

## 8. FAIL SAFE

None

## 9. ECM OPERATING AT DTC SETTING

Memorize the freeze frame data. (For test mode \$02)

# DIAGNOSTIC TROUBLE CODE (DTC) DETECTING CRITERIA

## GENERAL DESCRIPTION

### BA:DTC P0341 — CAMSHAFT POSITION SENSOR “A” CIRCUIT RANGE/PERFORMANCE (BANK 1 OR SINGLE SENSOR) —

#### 1. OUTLINE OF DIAGNOSIS

Detect the malfunction of camshaft position sensor output property. Judge NG when the camshaft line signal input timing is shifted from the crankshaft signal because of timing belt tooth chip, etc.

#### 2. COMPONENT DESCRIPTION

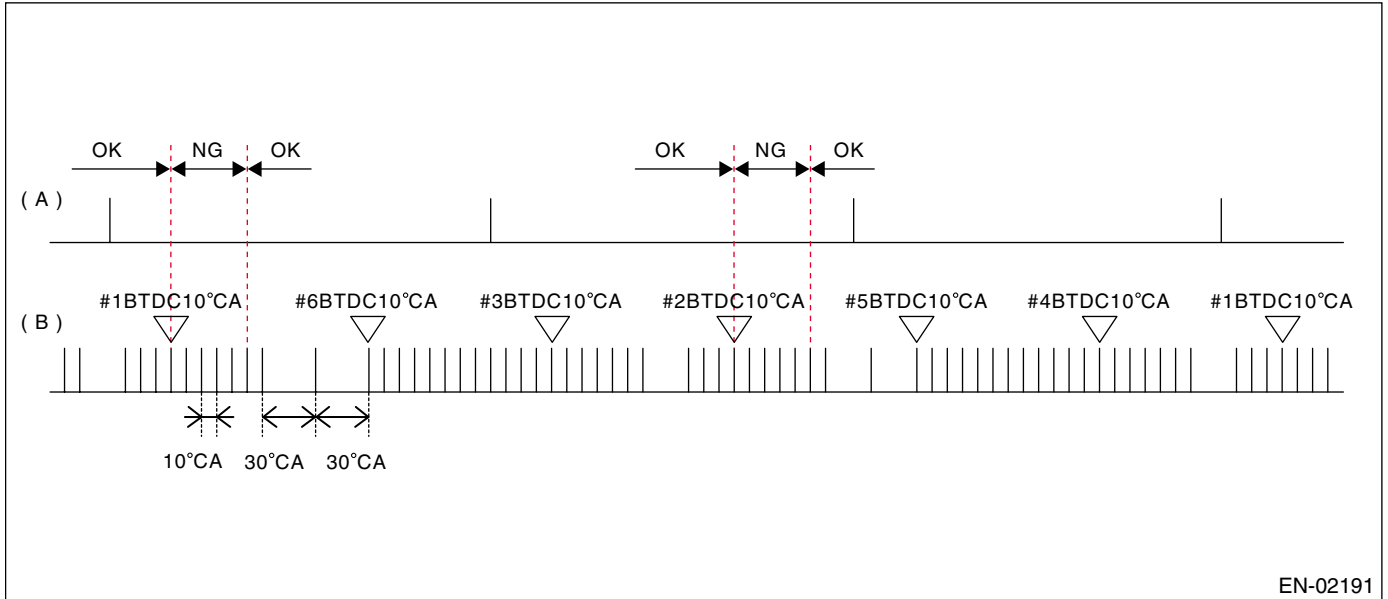

EN-02191

(A) Camshaft signal

(B) Crankshaft signal

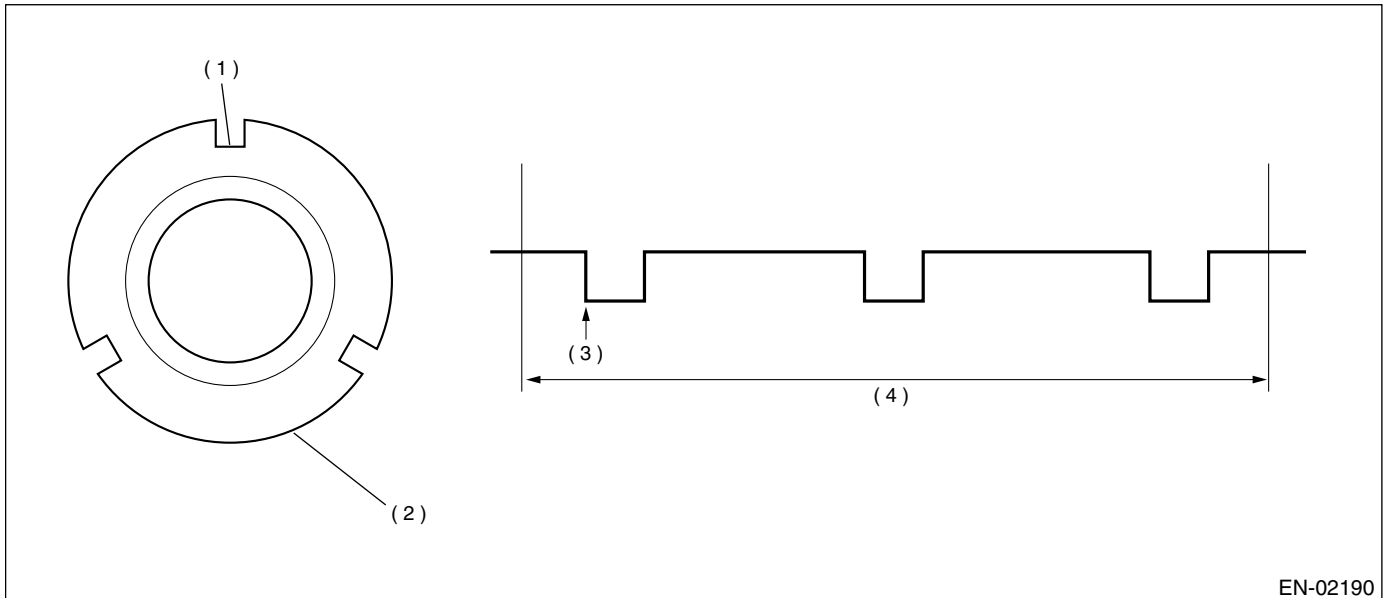

EN-02190

(1) Boss

(2) Camshaft sprocket

(3) Air gap

(4) Camshaft position sensor

(5) Camshaft one revolution (Engine two revolutions)

# DIAGNOSTIC TROUBLE CODE (DTC) DETECTING CRITERIA

GENERAL DESCRIPTION

## 3. ENABLE CONDITION

Secondary Parameters	Enable Conditions
Cylinder number distinction	Completed
Battery voltage	$\geq 8$ V
Engine speed	550 $\longleftrightarrow$ 1000 rpm
Engine operation	In idle
Misfire	Not detect

## 4. GENERAL DRIVING CYCLE

Perform the diagnosis at idling continuously.

## 5. DIAGNOSTIC METHOD

Judge NG when the engine speed continues 4 revolutions for the malfunction criteria below. Judge OK and clear the NG when the malfunction criteria below are not completed.

### Judgment Value

Malfunction Criteria	Threshold Value
Position of camshaft position sensor signal	Between #1 BTDC 10°CA and #6 BTDC 80°CA or between #2 BTDC 10°CA and #5 BTDC 80°CA

**Time Needed for Diagnosis:** 4 revs.

**Malfunction Indicator Light Illumination:** Illuminates when malfunction occurs in 2 continuous driving cycles.

## 6. DTC CLEAR CONDITION

- When the OK idling cycle was completed 40 times in a row
- When "Clear Memory" was performed

## 7. MALFUNCTION INDICATOR LIGHT CLEAR CONDITION

- When the OK driving cycle was completed 3 times in a row
- When "Clear Memory" was performed

## 8. FAIL SAFE

None

## 9. ECM OPERATING AT DTC SETTING

Memorize the freeze frame data. (For test mode \$02)

# DIAGNOSTIC TROUBLE CODE (DTC) DETECTING CRITERIA

## GENERAL DESCRIPTION

### BB:DTC P0400 — EXHAUST GAS RECIRCULATION FLOW —

#### 1. OUTLINE OF DIAGNOSIS

Detect the malfunction of EGR system.

Intake manifold pressure (negative pressure) is stable because the throttle valve is fully closed during the fuel shut-off in deceleration. In this case, the intake manifold pressure changes when EGR valve is opened or closed. Judge EGR system is OK or NG according to intake manifold pressure change amount.

#### 2. COMPONENT DESCRIPTION

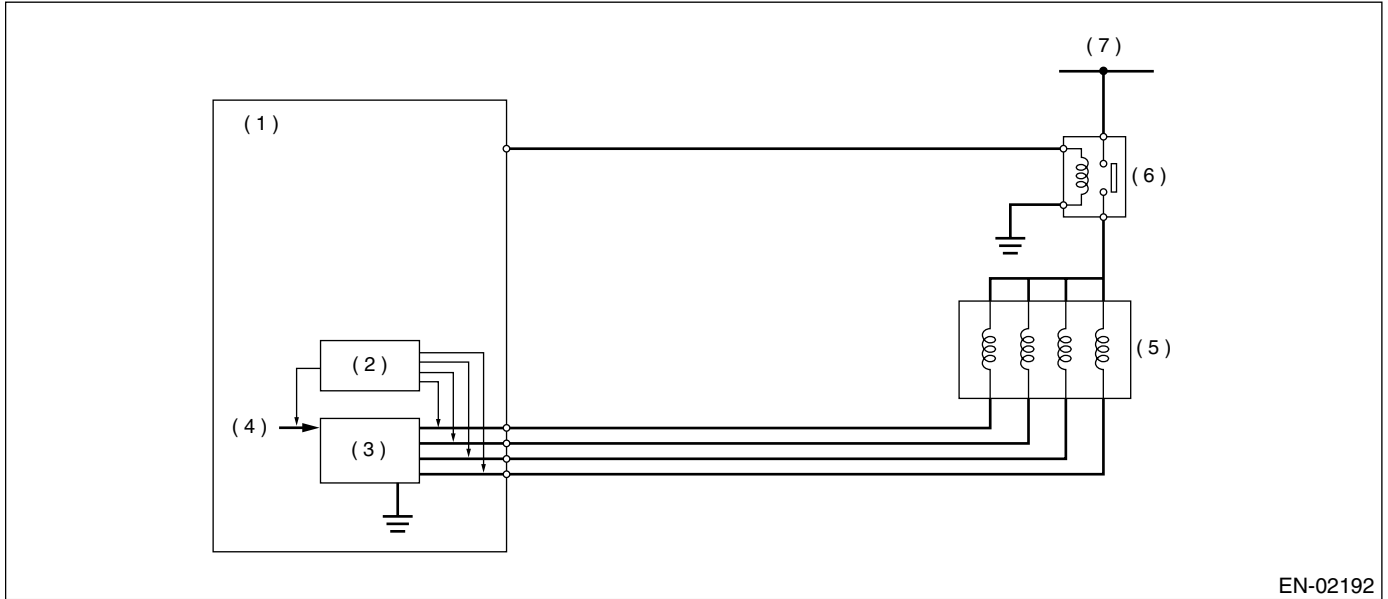

EN-02192

(1) ECU

(2) Detecting circuit

(3) Switching circuit

(4) CPU

(5) EGR valve

(6) Main relay

(7) Battery power



# DIAGNOSTIC TROUBLE CODE (DTC) DETECTING CRITERIA

GENERAL DESCRIPTION

## 3. ENABLE CONDITION

Secondary Parameters	Enable Conditions
After engine starting	40 secs. or more
Engine coolant temperature	$\geq 75^{\circ}\text{C}$ ( $167^{\circ}\text{F}$ )
Engine speed	1050 — 3000 rpm
Intake manifold pressure (absolute pressure)	$17.3 \longleftrightarrow 33.3$ kPa ( $130 \longleftrightarrow 250$ mmHg, $5.12 \longleftrightarrow 9.84$ inHg)
Estimated ambient temperature	$\geq 5^{\circ}\text{C}$ ( $41^{\circ}\text{F}$ )
Throttle position	$< 0.33^{\circ}$
Battery voltage	$> 10.9$ V
Atmospheric pressure	$\geq 75.0$ kPa (563 mmHg, 22.17 inHg)
Vehicle speed	$\geq 49$ km/h (30 MPH)
Fuel shut-off function	Operation
Neutral switch	Off or 5 seconds changing from “on” to “off”
After input switch operation (air conditioner, power steering, lights, rear defroster, heater fan and radiator fan)	There is no change for 5 seconds or more.
Intake manifold vacuum	$-26.7$ kPa ( $-200$ mmHg, $-7.87$ inHg)

## 4. GENERAL DRIVING CYCLE

Perform the diagnosis only once at the fuel shut-off in deceleration in vehicle speed 49 km/h (approx. 30 MPH). Pay attention to vehicle speed and engine speed. (The diagnosis is not completed if vehicle speed and engine speed are out of condition due to deceleration.)

# DIAGNOSTIC TROUBLE CODE (DTC) DETECTING CRITERIA

## GENERAL DESCRIPTION

### 5. DIAGNOSTIC METHOD

Measure the pressure in the following procedures when the enable conditions are completed, and then diagnosis by calculating the result.

- (1) PMOF1 is equal to the intake manifold pressure at enable condition completed, and EGR target step is set to 40 steps (almost fully opened).
- (2) PMON is equal to the intake manifold pressure in 1 second after EGR target step is set 40 steps (when enable conditions are completed), and EGR target step is set to 0 step.
- (3) PMOF2 is equal to the intake manifold pressure in 1 second after EGR target step is set to 0 step (in 2 seconds after enable conditions are completed).

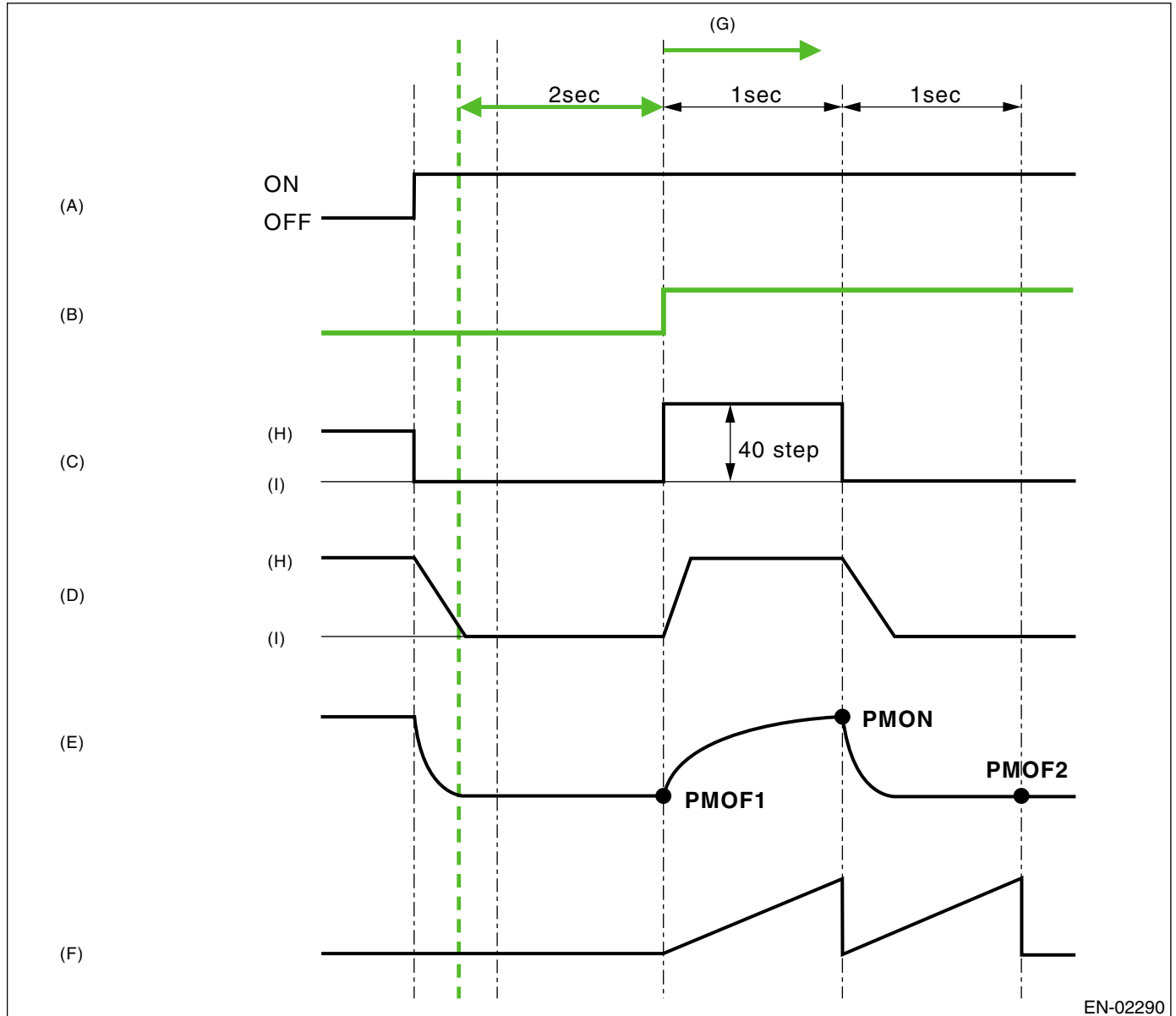

EN-02290

- (A) Fuel shut-off in deceleration
- (B) Diagnosis enable condition
- (C) EGR target step
- (D) EGR actual step

- (E) Intake manifold pressure (At normal condition)
- (F) Diagnosis mode timer
- (G) Diagnosis starts.

- (H) Open
- (I) Close

# DIAGNOSTIC TROUBLE CODE (DTC) DETECTING CRITERIA

GENERAL DESCRIPTION

4) Calculate the judged value using the following formula.

$$\text{Judged value} = [\text{PMON} - (\text{PMOF1} + \text{PMOF2})/2]$$

Judge NG when the malfunction criteria bellows are completed. Judge OK and clear NG when the malfunction criteria bellows are not completed.

## Judgment Value

Malfunction Criteria	Threshold Value
Judged value	< 1.57 kPa (11.8 mmHg, 0.465 inHg)

**Time Needed for Diagnosis:** 3 seconds

**Malfunction Indicator Light Illumination:** Illuminates when malfunction occurs in 2 continuous driving cycles.

## 6. DTC CLEAR CONDITION

- When the OK idling cycle was completed 40 times in a row
- When "Clear Memory" was performed

## 7. MALFUNCTION INDICATOR LIGHT CLEAR CONDITION

- When the OK driving cycle was completed 3 times in a row
- When "Clear Memory" was performed

## 8. FAIL SAFE

- Decrease compensation when operating EGR operate
- Front O<sub>2</sub> (A/F) sensor main learning compensation
- Calculation of basic advance ignition timing
- Knock learning compensation
- ISC control
- EGR control

## 9. ECM OPERATION AT DTC SETTING

- Memorize the freeze frame data. (For test mode \$02)
- Memorize the diagnosis value and trouble standard value. (For test mode \$06)

# DIAGNOSTIC TROUBLE CODE (DTC) DETECTING CRITERIA

## GENERAL DESCRIPTION

### BC:DTC P0420 — CATALYST SYSTEM EFFICIENCY BELOW THRESHOLD (BANK 1) —

#### 1. OUTLINE OF DIAGNOSIS

Detect the deterioration of catalyst function.

Though the rear oxygen sensor output would change slowly with a new catalyst, the sensor output with a deteriorated catalyst becomes high and the inversion time is shortened. For this reason, the catalyst diagnosis is carried out by monitoring the rear oxygen sensor output and comparing it with the front A/F sensor output.

#### 2. COMPONENT DESCRIPTION

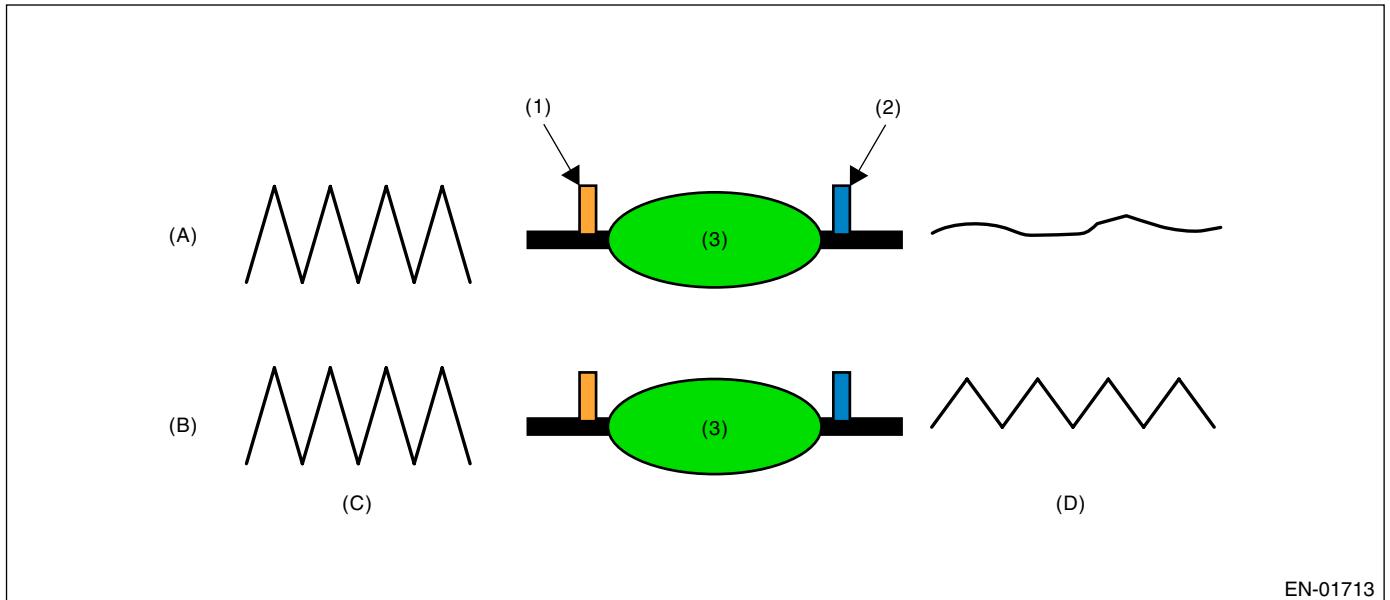

EN-01713

- (1) Front oxygen (A/F) sensor
- (2) Rear oxygen sensor
- (3) Catalyst

- (A) Normal
- (B) Deterioration

- (C) Front oxygen (A/F) sensor waveform
- (D) Rear oxygen sensor waveform

# DIAGNOSTIC TROUBLE CODE (DTC) DETECTING CRITERIA

GENERAL DESCRIPTION

## 3. ENABLE CONDITION

Secondary Parameters	Enable Conditions
Time for keep completing all secondary parameters	1.2 seconds or more
Battery voltage	> 10.9 V
Atmospheric pressure	> 75.1 kPa (563 mmHg, 22.2 inHg)
Engine coolant temperature	≥ 60°C (140°F)
Catalyst warm-up counter on Map 2	≥ 8000
Misfire detection during 200 engine revs.	< 5 times
Sub feedback	Operating
Evaporative system diagnostic	Not in operation
Difference between actual and target time lambda < 0.10	1000 milliseconds or more
Vehicle speed	≥ 70 km/h (43 MPH)
Amount of intake air	10 ↔ 40 g (0.35 — 1.41 oz)/s
Engine load change every 0.5 engine revs.	< 1.3 kPa (10 mmHg, 0.39 inHg)
Rear O <sub>2</sub> output change from below 600 mV to over	Experienced after fuel cut
After engine starting	150 milliseconds

### • Map 2

Add the following value every 512 milliseconds.

Amount of intake air (g (oz)/s)	0 (0)	3.2 (0.113)	6.4 (0.226)	9.6 (0.339)	12.8 (0.451)	16 (0.564)	19.2 (0.677)	22.4 (0.790)	25.6 (0.903)	28.8 (1.016)	32 (1.129)	35.2 (1.242)
Integrated value for warm-up counter	-5	-5	8	25	41	58	75	92	108	125	127	127

## 4. GENERAL DRIVING CYCLE

Perform the diagnosis once at the constant vehicle speed more than 70 km/h (43 MPH).

## 5. DIAGNOSTIC METHOD

After the malfunction criterias are completed, calculate the output fluctuation value of front oxygen (A/F) sensor (average of left and right) and output fluctuation value of rear oxygen sensor.

Calculate the diagnosis value when the front oxygen (A/F) sensor output fluctuation value more than specified value.

Regard the A/F response properties and diagnosis value as parameters for judgment value.

Judge NG when the malfunction criteria below are completed, and judge OK when they are not completed.

### Judgment Value

Malfunction Criteria	Threshold Value
Accumulated variation of output voltage of rear oxygen sensor per 32 milliseconds × 4 divided by accumulated variation of lambda of front oxygen (A/F) sensor per 32 milliseconds × 4	≥ 2.6

**Time Needed for Diagnosis:** 55 seconds

**Malfunction Indicator Light Illumination:** Illuminates when malfunction occurs in 2 continuous driving cycles.

# DIAGNOSTIC TROUBLE CODE (DTC) DETECTING CRITERIA

## GENERAL DESCRIPTION

---

### 6. DTC CLEAR CONDITION

- When the OK idling cycle was completed 40 times in a row
- When "Clear Memory" was performed

### 7. MALFUNCTION INDICATOR LIGHT CLEAR CONDITION

- When the OK driving cycle was completed 3 times in a row
- When "Clear Memory" was performed

### 8. FAIL SAFE

None

### 9. ECM OPERATION AT DTC SETTING

- Memorize the freeze frame data. (For test mode \$02)
- Memorize the diagnostic value and trouble standard value. (For test mode \$06)

# DIAGNOSTIC TROUBLE CODE (DTC) DETECTING CRITERIA

GENERAL DESCRIPTION

---

MEMO:

# DIAGNOSTIC TROUBLE CODE (DTC) DETECTING CRITERIA

## GENERAL DESCRIPTION

### BD:DTC P0442 — EVAPORATIVE EMISSION CONTROL SYSTEM LEAK DETECTED (SMALL LEAK) —

#### 1. OUTLINE OF DIAGNOSIS

Perform the diagnosis of leakage of fuels system and valve functions.

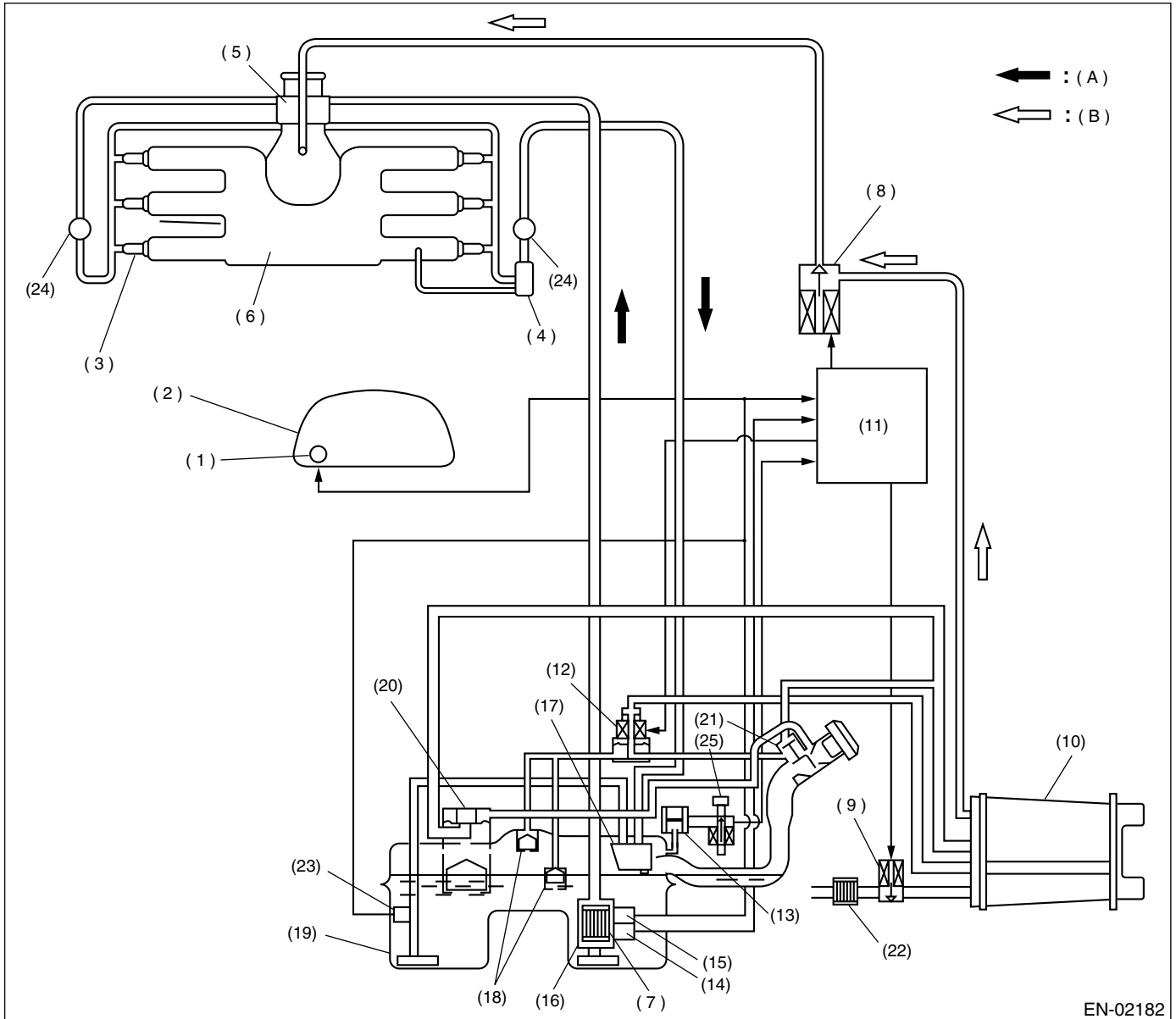

- |                                  |                                      |   |
|----------------------------------|--------------------------------------|---|
| (1) Fuel meter                   | (11) Engine control module (ECM)     | (21) Shut-off valve                         |
| (2) Combination meter            | (12) Pressure control solenoid valve | (22) Drain filter                           |
| (3) Fuel injector                | (13) Fuel tank pressure sensor       | (23) Fuel sub level sensor                  |
| (4) Pressure regulator           | (14) Fuel temperature sensor         | (24) Fuel damper                            |
| (5) Throttle body                | (15) Fuel level sensor               | (25) Tank pressure switching solenoid valve |
| (6) Intake manifold              | (16) Fuel pump                       | (A) Fuel line                               |
| (7) Fuel filter                  | (17) Jet pump                        | (B) Evaporation line                        |
| (8) Purge control solenoid valve | (18) Fuel cut valve                  |   |
| (9) Drain valve                  | (19) Fuel tank                       |   |
| (10) Canister                    | (20) Vent valve                      |   |



# DIAGNOSTIC TROUBLE CODE (DTC) DETECTING CRITERIA

GENERAL DESCRIPTION

In this system diagnosis, filter tank pressure. And leakage and normality & abnormality of valve operation are judged by monitoring the pressure change status using the fuel tank pressure sensor.

0.04 inch diagnosis is performed in the order of Mode Z, Mode A, Mode B, Mode C, Mode D. 0.02 inch diagnosis is performed in the order of Mode A, Mode B, Mode C, Mode D.

## 0.04-inch Diagnosis

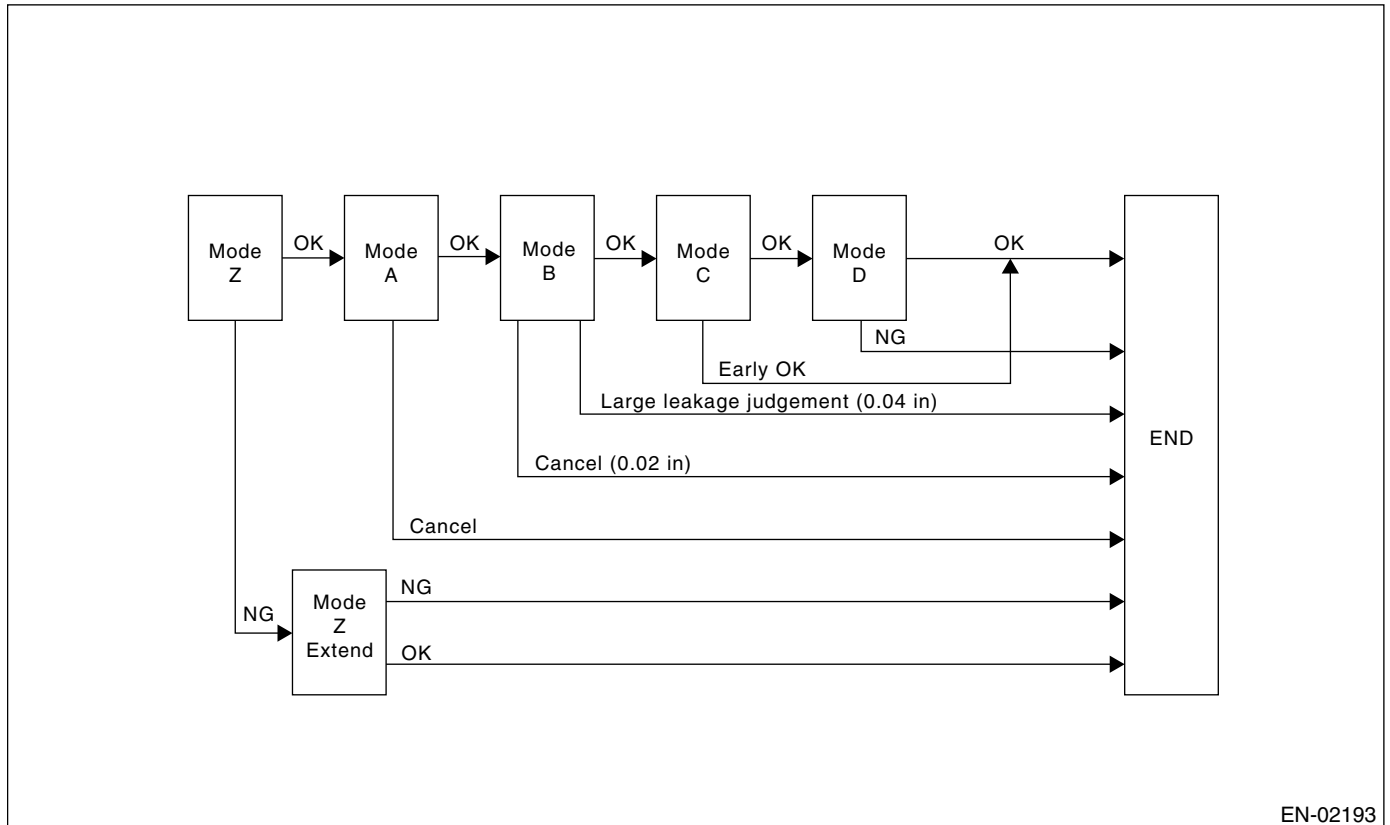

EN-02193

Mode	Mode Description	Diagnosis Period
Mode Z (Purge control solenoid valve open fail diagnosis)	Perform the diagnosis of purge control solenoid valve open fail depending on the amount of the tank pressure change.	3 — 16 seconds
Mode A (Evaluation of EVAP. generation amount)	Calculate the tank pressure change amount (P1).	10 seconds
Mode B (Negative pressure sealed/large leak judgment)	Operating the purge control solenoid valve, introduce the intake manifold pressure into the fuel tank. If the tank pressure cannot be reduced, diagnose that there is large leakage.	5 — 60 seconds
Mode C (Pressure increase check/premature OK judgment)	Wait until the tank pressure returns to the target value (pressure to start calculating P2). If the pressure does not return, perform the premature OK judgment.	1 — 15 seconds
Mode D (Negative pressure change amount measurement/EVAP. leakage diagnosis)	Calculate the tank pressure change amount (P2), and measure the diagnosis value using P1 calculated in Mode A. Perform the EVAP. leakage diagnosis using the diagnosis value.	10 seconds

# DIAGNOSTIC TROUBLE CODE (DTC) DETECTING CRITERIA

## GENERAL DESCRIPTION

### 0.02-inch Diagnosis

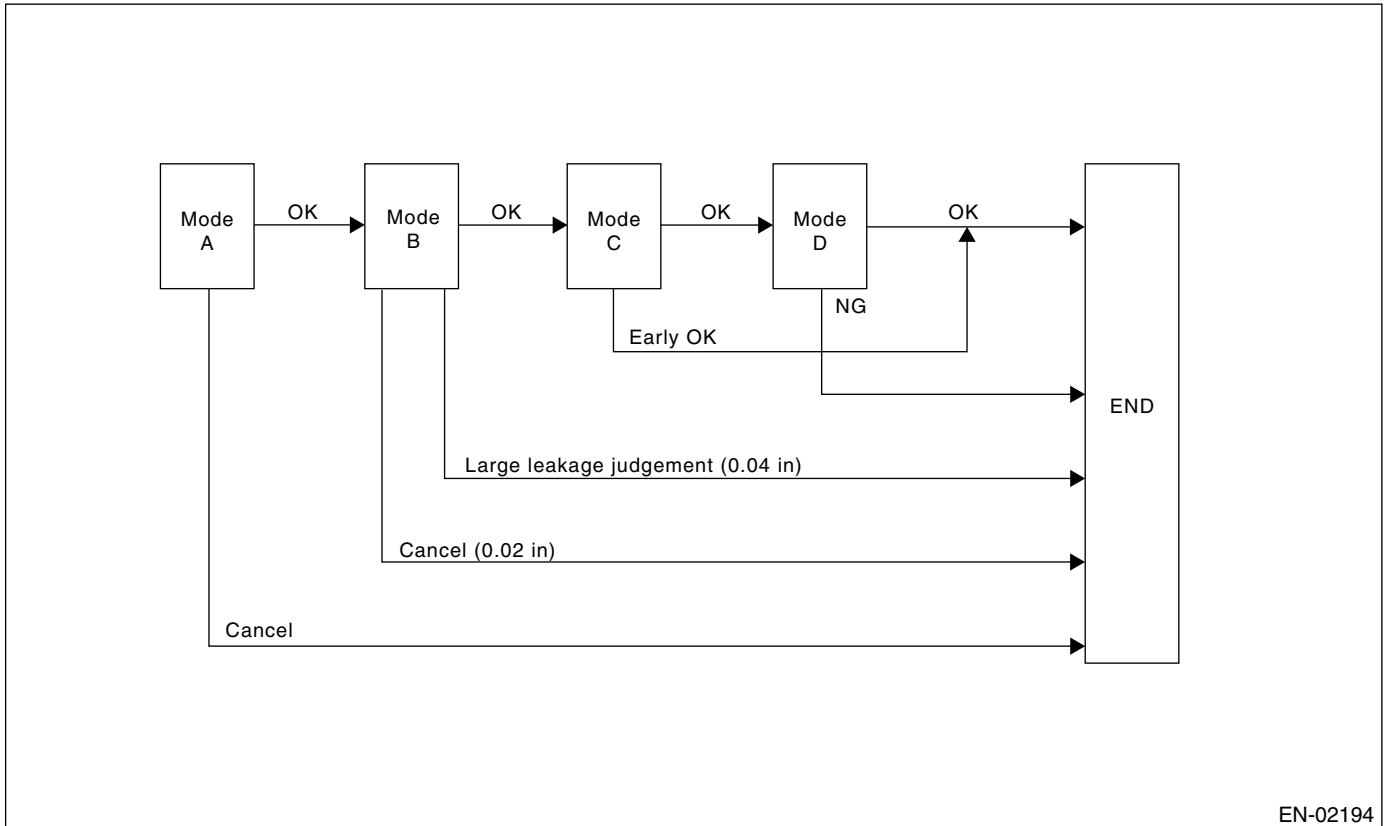

EN-02194

Mode	Mode Description	Diagnosis Period
Mode A (Evaluation of EVAP. generation amount)	Calculate the tank pressure change amount (P1).	26 seconds
Mode B (Negative pressure seal)	Introduce the intake manifold pressure into the fuel tank, and reduce the tank pressure to the target pressure.	5 — 15 seconds
Mode C (Pressure increase check/premature OK judgment)	Wait until the tank pressure returns to the target value (pressure to start calculating P2). If the tank pressure does not return, perform the premature OK judgment.	1 — 20 seconds
Mode D (Negative pressure change amount measurement/EVAP. leakage diagnosis)	Calculate the tank pressure change value (P2), measure the diagnosis value using P1 calculated in Mode A. Perform the EVAP. leakage diagnosis using the diagnosis value.	22 seconds

### Mode table for Evaporative Emission Control System diagnosis

Mode	Normal conditions	Diagnostic item	DTC
Mode Z	Nearly same as atmospheric pressure (equivalent pressure of 0 kPa (0 mmHg, 0 inHg))	CPC is judged to be stuck open.	P0457
Mode A	Pressure is in proportion to amount of evaporative emission.	—	—
Mode B	Negative pressure is formed due to intake manifold negative pressure	Judged as large leak	P0457
Mode C	Target pressure is undershot after CPC is closed.	—	—
Mode D	Pressure change is small.	EVAP system is judged to have small leak [1.0 mm (0.04 in)].	P0442
		P2 of small leak in system is measured and EVAP system is judged to have very small leak [0.5 mm (0.02 in)].	P0456

## 2. COMPONENT DESCRIPTION

### • Pressure Control Solenoid Valve

Pressure control solenoid valve maintains the fuel tank pressure equal to the atmospheric air pressure. Normally, the solenoid is set to OFF, and the valve mechanically opens and closes in accordance with the difference between the tank pressure and atmospheric air pressure, and the tank pressure and canister pressure.

During the diagnosis, the valve is forcibly opened by setting the solenoid to ON.

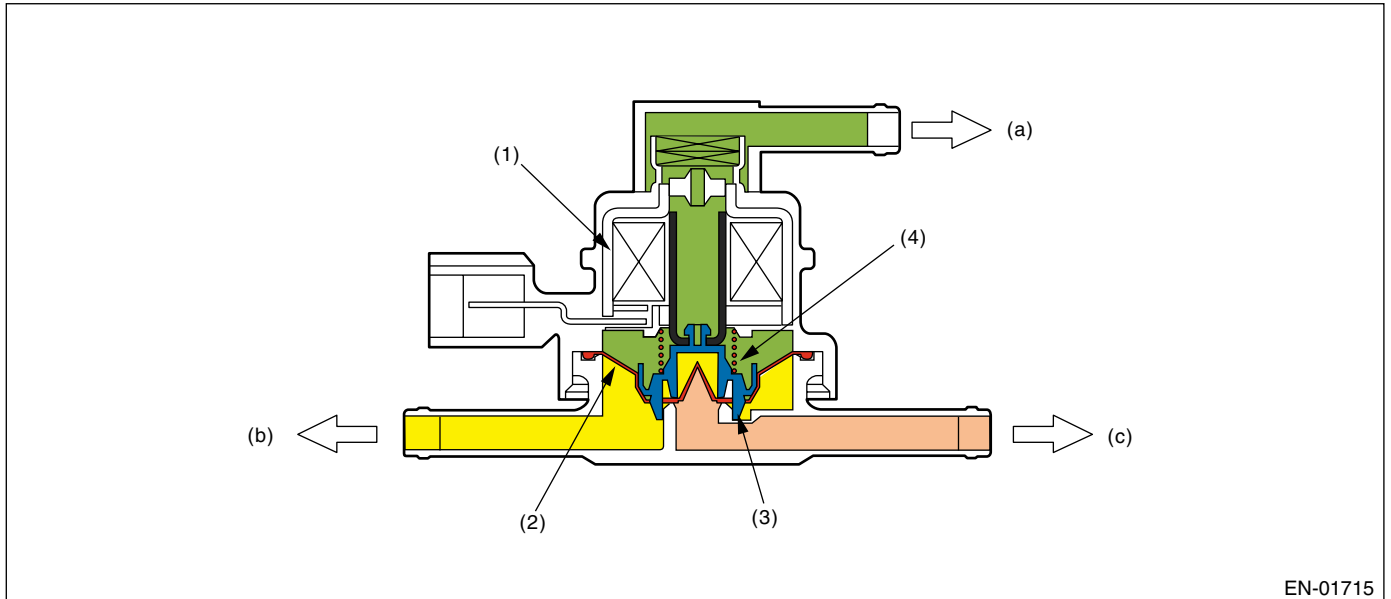

- |               |                          |
|---------------|--------------------------|
| (1) Solenoid  | (a) Atmospheric pressure |
| (2) Diaphragm | (b) Fuel tank            |
| (3) Valve     | (c) Canister             |
| (4) Spring    |                          |

# DIAGNOSTIC TROUBLE CODE (DTC) DETECTING CRITERIA

## GENERAL DESCRIPTION

### • Valve Operation and Air Flow

As in the X parts below, there are the area with atmospheric air pressure above the diaphragm and the area with tank pressure below the diaphragm. Also, as in the Y parts below, there are the area with tank pressure above the diaphragm and the area with canister pressure below the diaphragm. In the table below the air flow from each port in accordance with pressure difference is shown with the atmospheric air pressure port A, tank pressure port B and canister pressure port C.

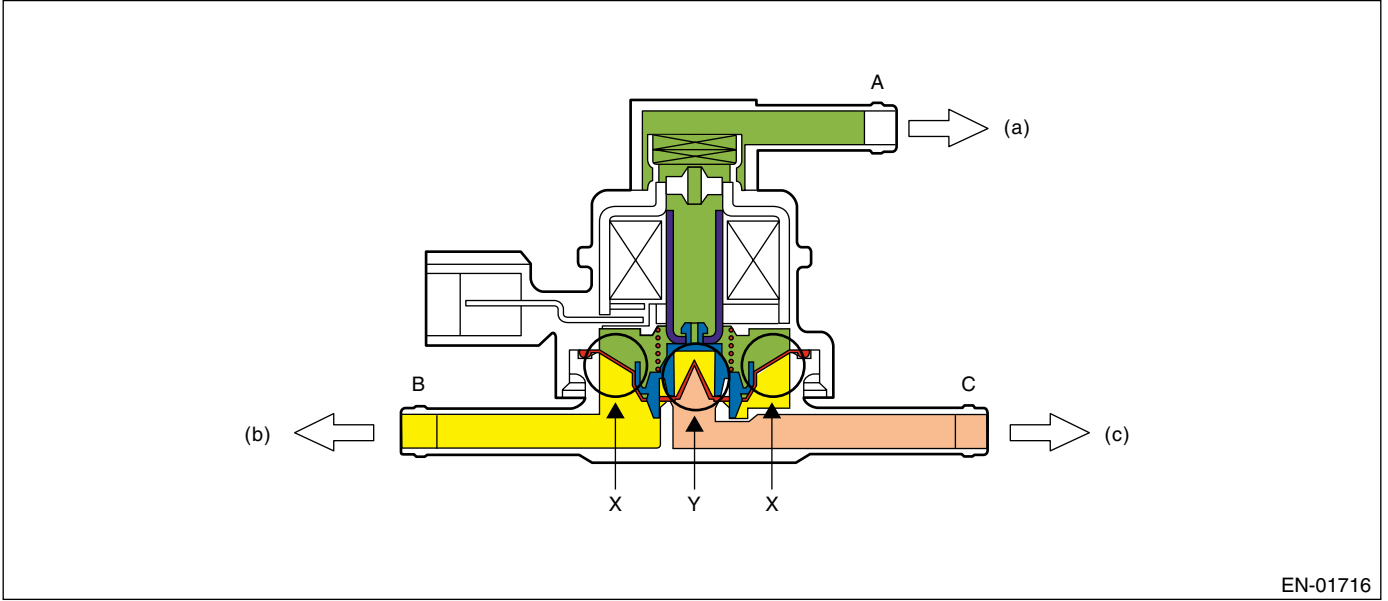

(a) Atmospheric pressure

(b) Fuel tank

(c) Canister

Pressure Status	Flow
$A < B$ (Solenoid OFF)	$B \rightarrow C$
$B < C$ (Solenoid OFF)	$C \rightarrow B$
Solenoid ON	$B \leftrightarrow C$

### • When $A < B$ (Solenoid OFF)

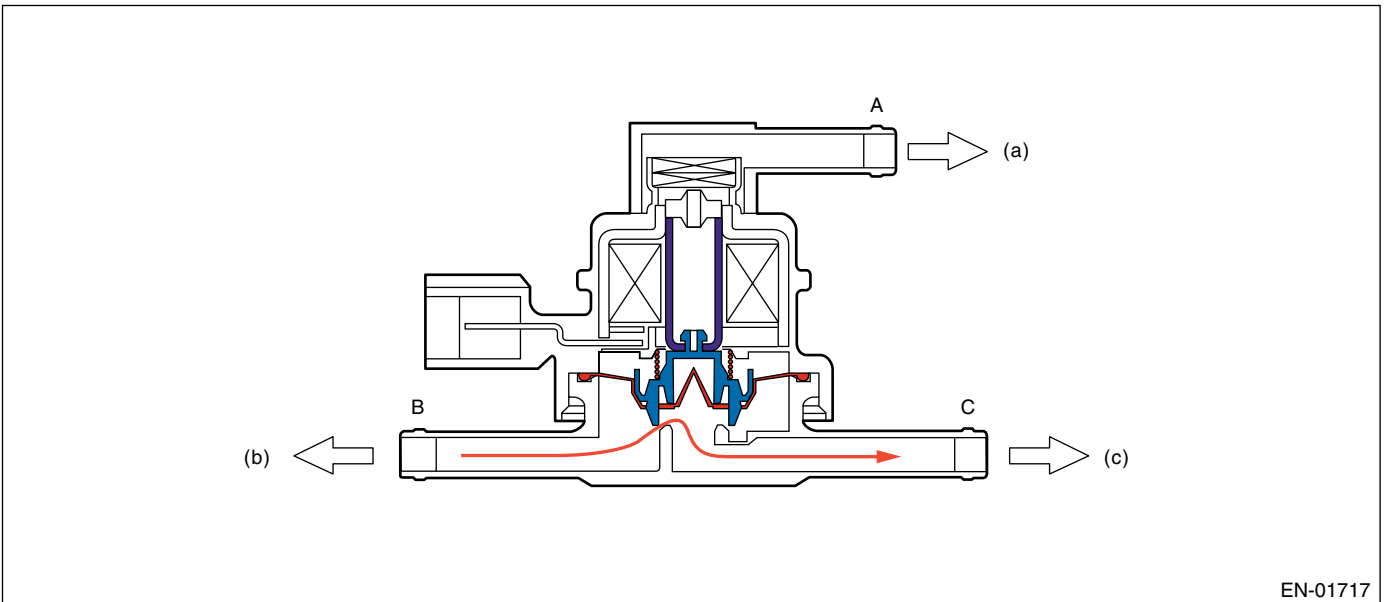

(a) Atmospheric pressure

(b) Fuel tank

(c) Canister

# DIAGNOSTIC TROUBLE CODE (DTC) DETECTING CRITERIA

GENERAL DESCRIPTION

## • When $B < C$ (Solenoid OFF)

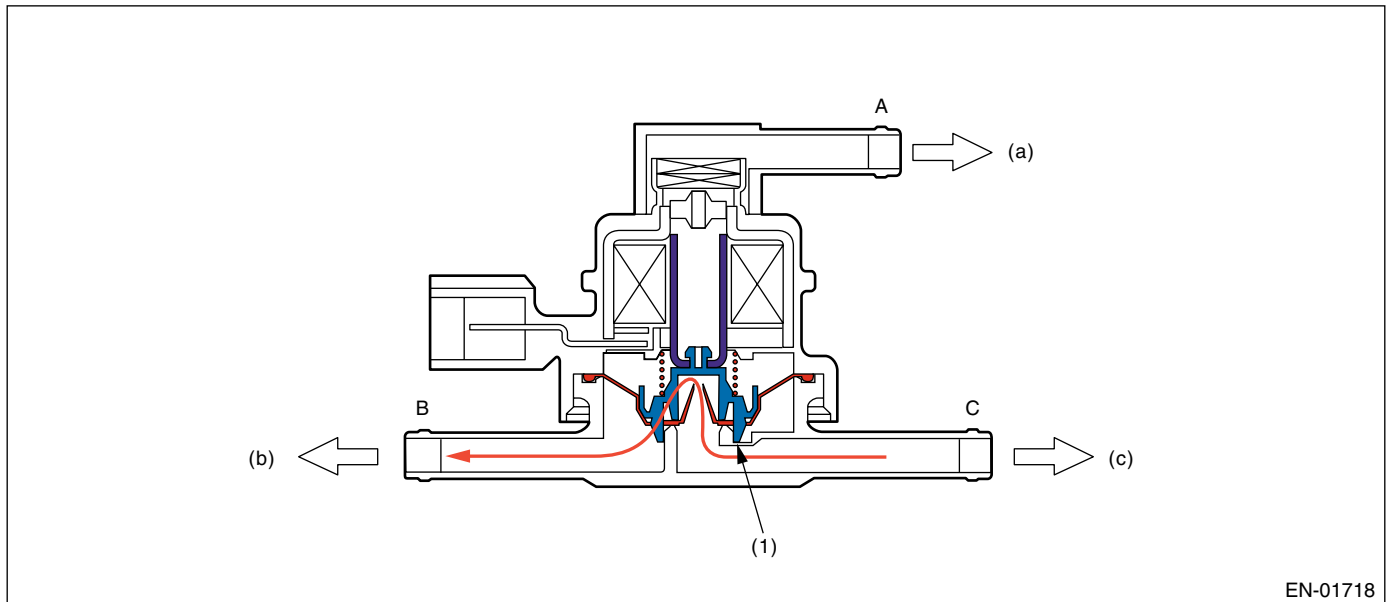

(1) Valve

(a) Atmospheric pressure

(b) Fuel tank

(c) Canister

## • When solenoid is ON

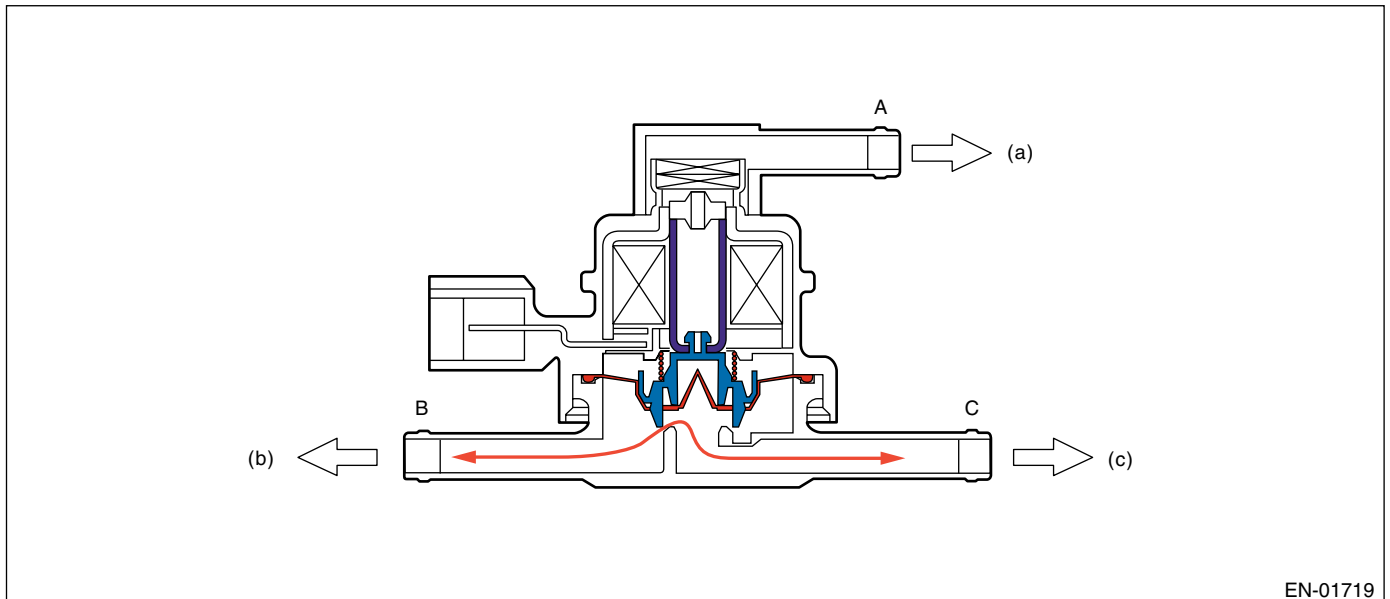

(a) Atmospheric pressure

(b) Fuel tank

(c) Canister

# DIAGNOSTIC TROUBLE CODE (DTC) DETECTING CRITERIA

## GENERAL DESCRIPTION

- **Drain valve**

Drain valve controls the ambient air to be introduced to the canister. Normally the solenoid is set to OFF and the valve is open. The valve is closed when the solenoid is set to ON only at the time of diagnosis.

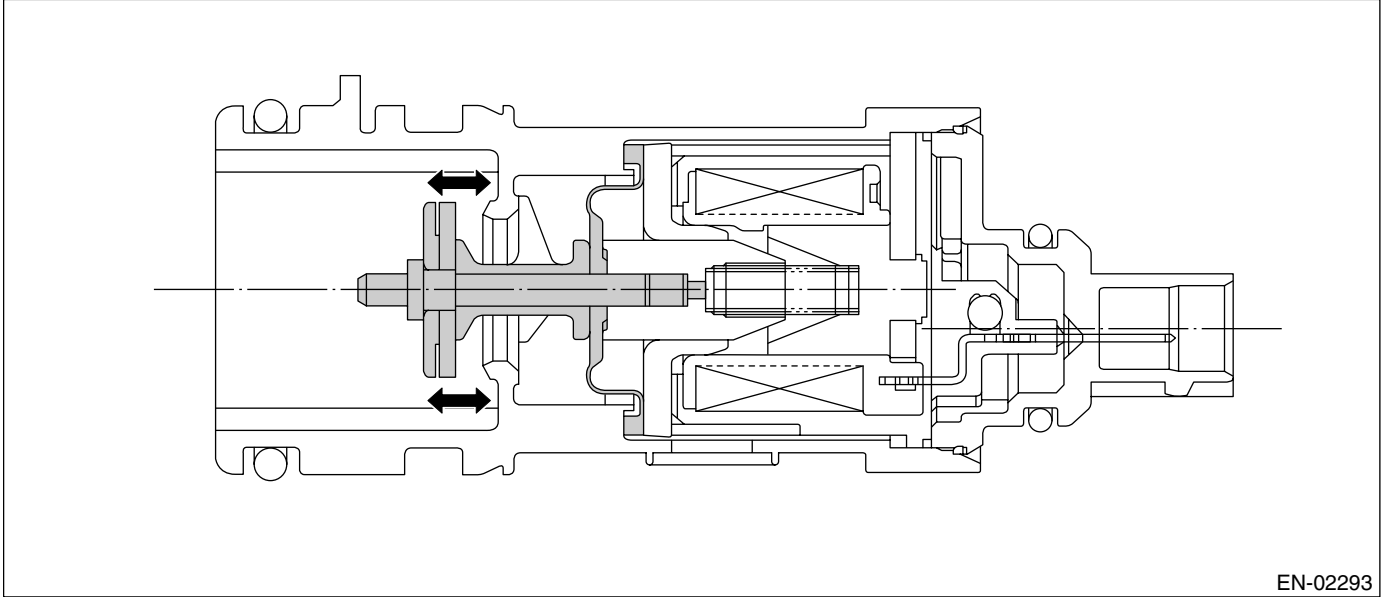

# DIAGNOSTIC TROUBLE CODE (DTC) DETECTING CRITERIA

GENERAL DESCRIPTION

## • Tank Pressure Switching Solenoid

Fuel tank sensor control valve is connected to fuel tank pressure sensor and opened to atmosphere. In normal condition, fuel tank sensor control valve is OFF, and circuit of fuel pressure sensor is open to atmosphere. If fuel tank sensor control valve is ON, then circuit is closed.

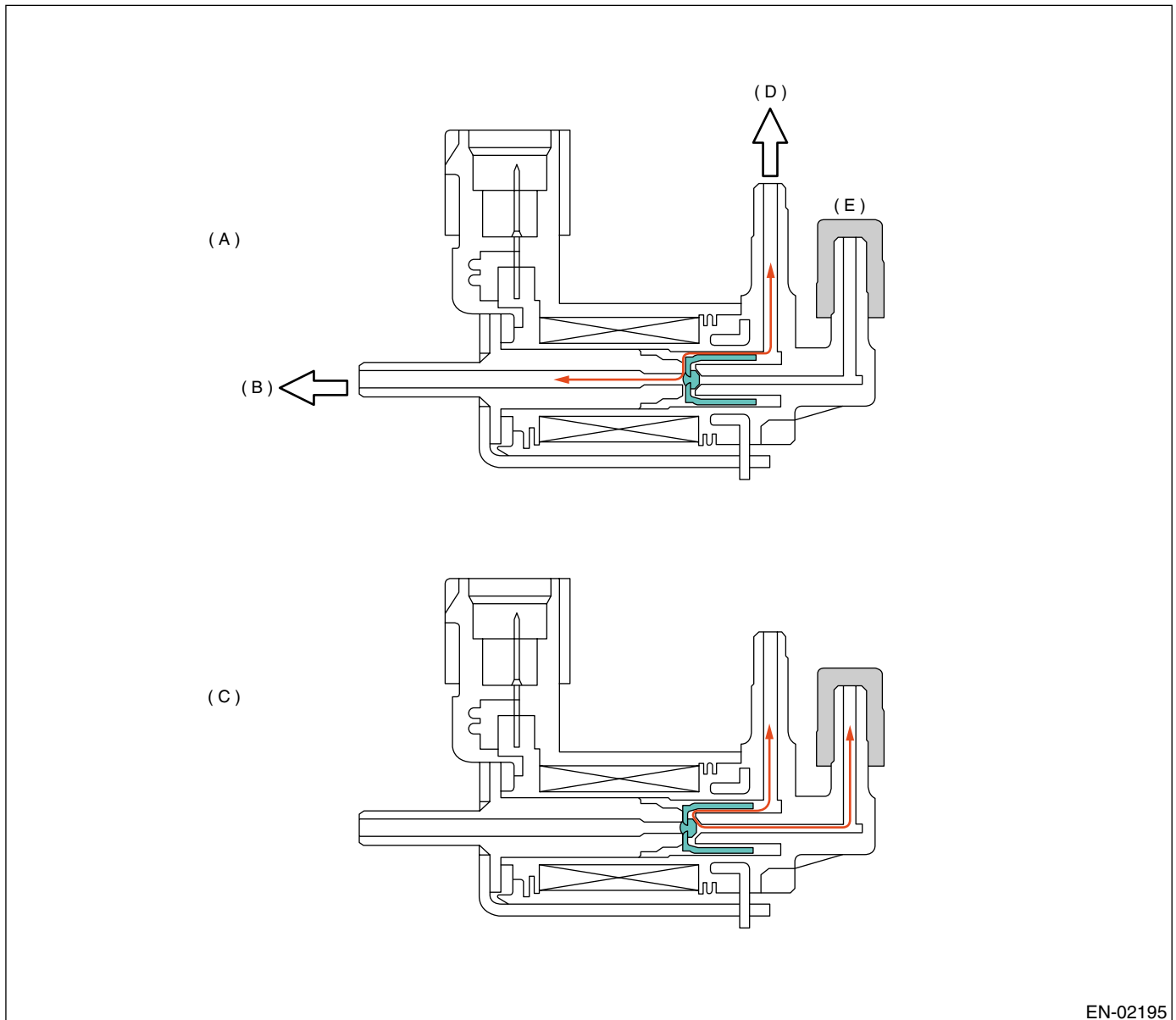

EN-02195

(A) Open atmosphere (solenoid OFF)  
(B) Ambient air

(C) During trouble diagnosis (solenoid ON)

(D) To pressure sensor  
(E) Plug

# DIAGNOSTIC TROUBLE CODE (DTC) DETECTING CRITERIA

## GENERAL DESCRIPTION

### Purpose of this solenoid

Fuel tank pressure sensor detects the difference between the atmospheric air pressure and the tank pressure, and the ECM monitors the pressure difference.

Even if the tank pressure is constant, the atmospheric air pressure varies depending on the driving height, and the pressure signal transmitted to ECM will change.

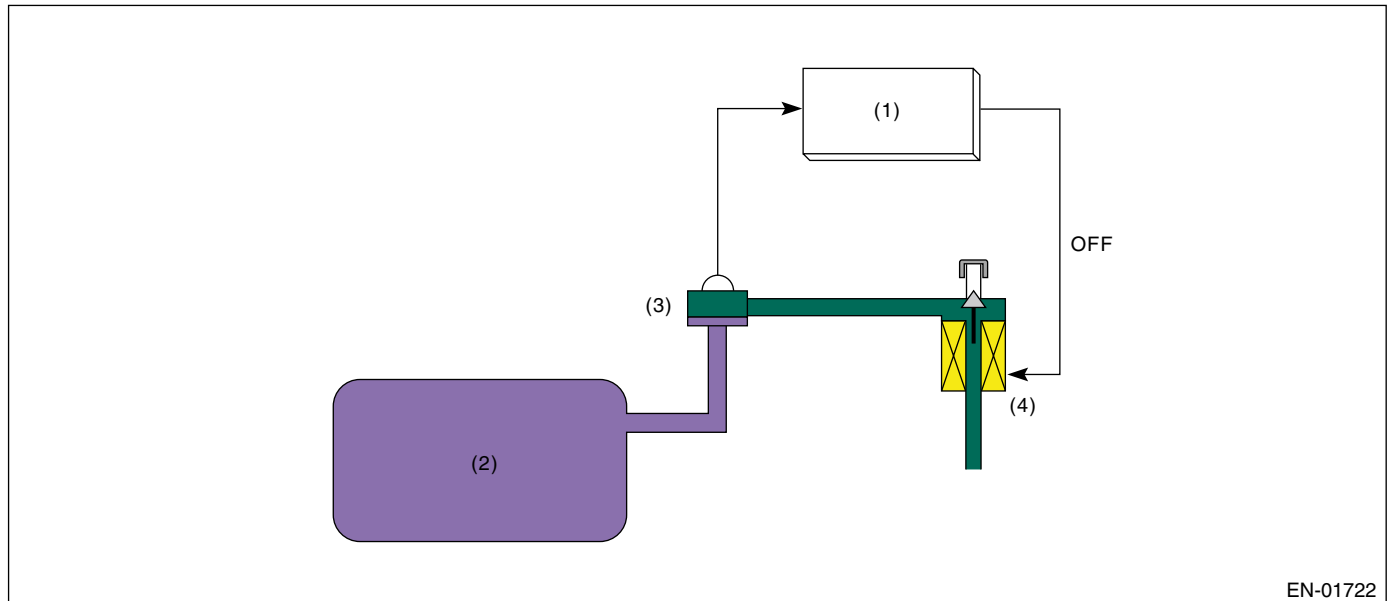

EN-01722

- (1) Engine control module (ECM)
- (2) Fuel tank
- (3) Fuel tank pressure sensor

- (4) Atmospheric pressure switching solenoid



# DIAGNOSTIC TROUBLE CODE (DTC) DETECTING CRITERIA

GENERAL DESCRIPTION

Especially, in the small leakage [0.5 mm (0.02 inch)], minute change in the tank pressure has to be detected. This diagnosis period is long (approx. 29 seconds). And if the driving height changes during the diagnosis, the atmospheric air pressure changes. In this case, it becomes difficult to precisely detect the tank pressure variation, causing erroneous diagnosis. Therefore, using the atmospheric pressure switching solenoid, atmospheric air is sealed between the fuel tank pressure sensor and atmospheric pressure switching solenoid, maintaining the air pressure constant and enabling the detection of minute variation of tank pressure.

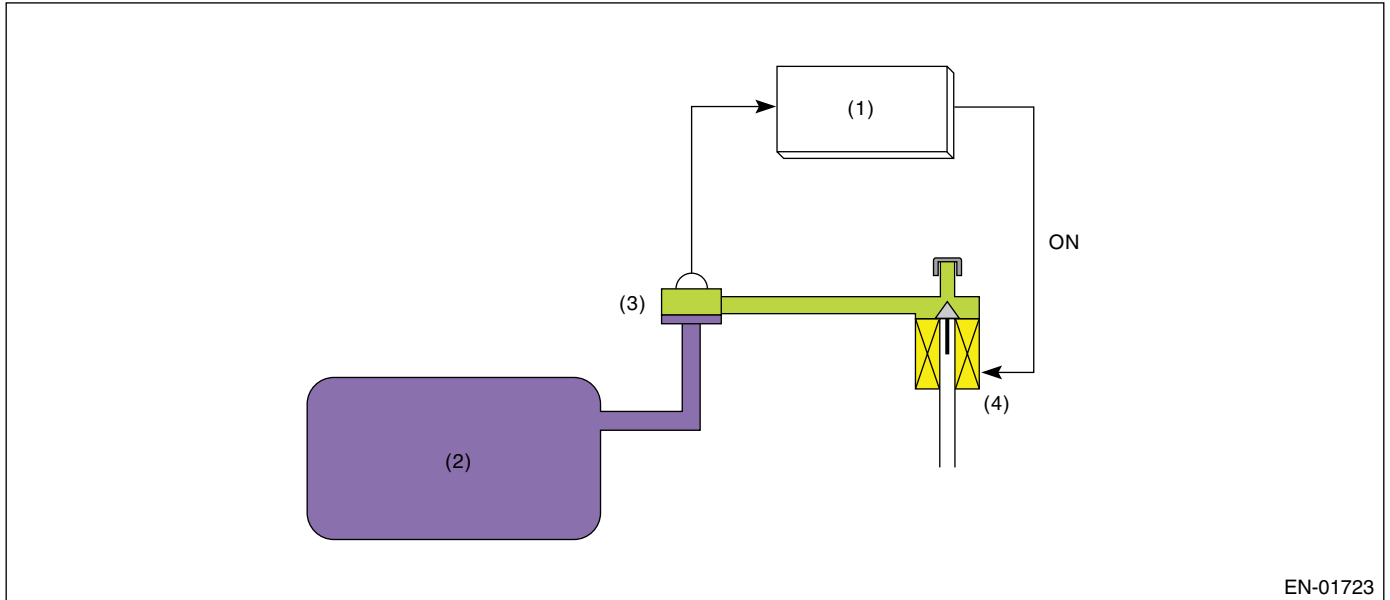

- (1) Engine control module (ECM)
- (2) Fuel tank
- (3) Fuel tank pressure sensor
- (4) Atmospheric pressure switching solenoid

## NOTE:

ECM also has the atmospheric air pressure sensor, and always monitors atmospheric air. However, as the monitoring range is large, that is, 53.3 to 107 kPa (400 to 800 mmHg, 15.7 to 31.6 inHg), it is not suitable for detection of minute pressure variation.

In the case of small leakage diagnosis, the tank pressure variation is very small, that is, 0.13 to 0.26 kPa (1 to 2 mmHg, 0.04 to 0.08 inHg), and the fuel tank pressure sensor is equipped.

# DIAGNOSTIC TROUBLE CODE (DTC) DETECTING CRITERIA

## GENERAL DESCRIPTION

### 3. ENABLE CONDITION

#### 0.04-inch Diagnosis

Secondary Parameters	Enable Conditions
Battery voltage	$\geq 10.9$ V
Barometric pressure	$\geq 75.1$ kPa (563 mmHg, 22.2 inHg)
After engine starting	843 seconds or more
Learning value of evaporation gas density (both left and right)	$\leq 0.16$
Engine speed	1400 $\leftrightarrow$ 3000 rpm
Fuel tank pressure	$\geq -1.3 \leftrightarrow 1.3$ kPa (-10 $\leftrightarrow$ 9.5 mmHg, -0.39 $\leftrightarrow$ 0.37 inHg)
Intake manifold vacuum (relative pressure)	$\leq -40.0$ kPa (-300 mmHg, -11.81 inHg)
Vehicle speed	$\geq 32$ km/h (20 MPH)
Fuel level	9.75 $\leftrightarrow$ 48 $\ell$ (10.3 $\leftrightarrow$ 50.7 US gal, 8.6 $\leftrightarrow$ 42.2 Imp gal)
A/F feedback control	In operation
Fuel temperature	$\leq 45^\circ\text{C}$ (113°F)
Intake air temperature	$\geq -10^\circ\text{C}$ (14°F)
Pressure change per second	$< 0.13$ kPa (0.96 mmHg, 0.04 inHg)
Min. pressure change per second – Max. pressure change per second	$< 0.37$ kPa (2.8 mmHg, 0.110 inHg)
Fuel level change	$< 3 \ell$ (3.2 US qt, 2.6 Imp qt)/131 milliseconds

# DIAGNOSTIC TROUBLE CODE (DTC) DETECTING CRITERIA

GENERAL DESCRIPTION

## 0.02-inch Diagnosis

Secondary Parameters	Enable Conditions
(At starting a diagnosis)	
Battery voltage	$\geq 10.9$ V
Atmospheric pressure	$\geq 75.1$ kPa (563 mmHg, 22.2 inHg)
Since last incomplete diagnosis event of 0.02-inch leakage	$> 120$ seconds
After engine starting	335 second or more
Fuel temperature $-10 \leftrightarrow 35^{\circ}\text{C}$ ( $14 \leftrightarrow 95^{\circ}\text{F}$ ), or the time after engine start with coolant temperature of $40^{\circ}\text{C}$ ( $104^{\circ}\text{F}$ ) or below	$< 2400$ seconds
Fuel level	$9.75 \leftrightarrow 48$ $\ell$ (2.6 $\leftrightarrow$ 12.7 US gal, 2.1 $\leftrightarrow$ 10.6 Imp gal)
(Ambient (estimate) – fuel) temperature	$< 1^{\circ}\text{C}$ ( $1.8^{\circ}\text{F}$ )
Fuel tank pressure below $-3.04$ kPa ( $-22.8$ mmHg, $-0.88$ inHg) (during same driving cycle, Intake manifold vacuum (relative pressure))	Up to 1 times
Intake manifold vacuum (relative pressure)	$\leq -8.0$ kPa ( $-60$ mmHg, $-2.36$ inHg)
Fuel tank pressure	$-0.1$ to $0.93$ kPa ( $-1$ to $7$ mmHg, $-0.04$ to $0.27$ inHg)
Vehicle speed	$\geq 68$ km/h (42 MPH)
A/F feedback control	In operation
Engine speed	$1400 \leftrightarrow 3000$ rpm
P1	$-0.20 \leftrightarrow 0.13$ kPa ( $-1.5 \leftrightarrow 1$ mmHg, $-0.06 \leftrightarrow 0.04$ inHg)
Pressure change per second	$< 0.25$ kPa (1.9 mmHg, 0.075 inHg)
Fuel level change	$2 \leftrightarrow 3$ $\ell$ (2.1 $\leftrightarrow$ 3.2 US gal, 1.8 $\leftrightarrow$ 2.6 Imp gal)/128 milliseconds
Tank pressure	$< 0.9$ kPa (7 mmHg, 0.28 inHg)
Min. tank pressure change per second – Max. tank pressure change per second	$< 0.08$ kPa (0.6 mmHg, 0.024 inHg)
Change of atmospheric pressure during P1 calculation	$-0.11 \leftrightarrow 0.19$ kPa ( $-0.85 \leftrightarrow 1.4$ mmHg, $-0.033 \leftrightarrow -0.055$ inHg)
Change of atmospheric pressure during P2 calculation	$-0.02 \leftrightarrow 0.13$ kPa ( $-0.15 \leftrightarrow 0.95$ mmHg, $0.006 \leftrightarrow 0.037$ inHg)

# DIAGNOSTIC TROUBLE CODE (DTC) DETECTING CRITERIA

## GENERAL DESCRIPTION

### 4. GENERAL DRIVING CYCLE

#### 0.04-inch Diagnosis

Perform the diagnosis only once in 843 seconds or more after starting the engine constantly at 32 km/h (19.9 MPH) or more.

Pay attention to the fuel temperature and fuel level.

#### 0.02-inch Diagnosis

Perform the diagnosis in 335 seconds after starting the engine constantly at 68 km/h (42 MPH) or more, and perform OK/NG judgment.

If OK/NG judgment is not possible, repeat the diagnosis.

Pay attention to the fuel temperature and fuel level.

### 5. DIAGNOSTIC METHOD

#### • Diagnosing Function of Drain Valve and Purge Control Solenoid Valve

#### DTC

P0457 Evaporative Emission Control System Leak Detected (Fuel Cap Loose/Off)

#### Purpose of Mode Z

When performing the leakage diagnosis of EVAP system, and CPC have to operate normally. Therefore, mode Z is used to diagnose the CPC open fixation.

If the CPC open fixation trouble is detected, the evaporation system leakage diagnosis is cancelled.

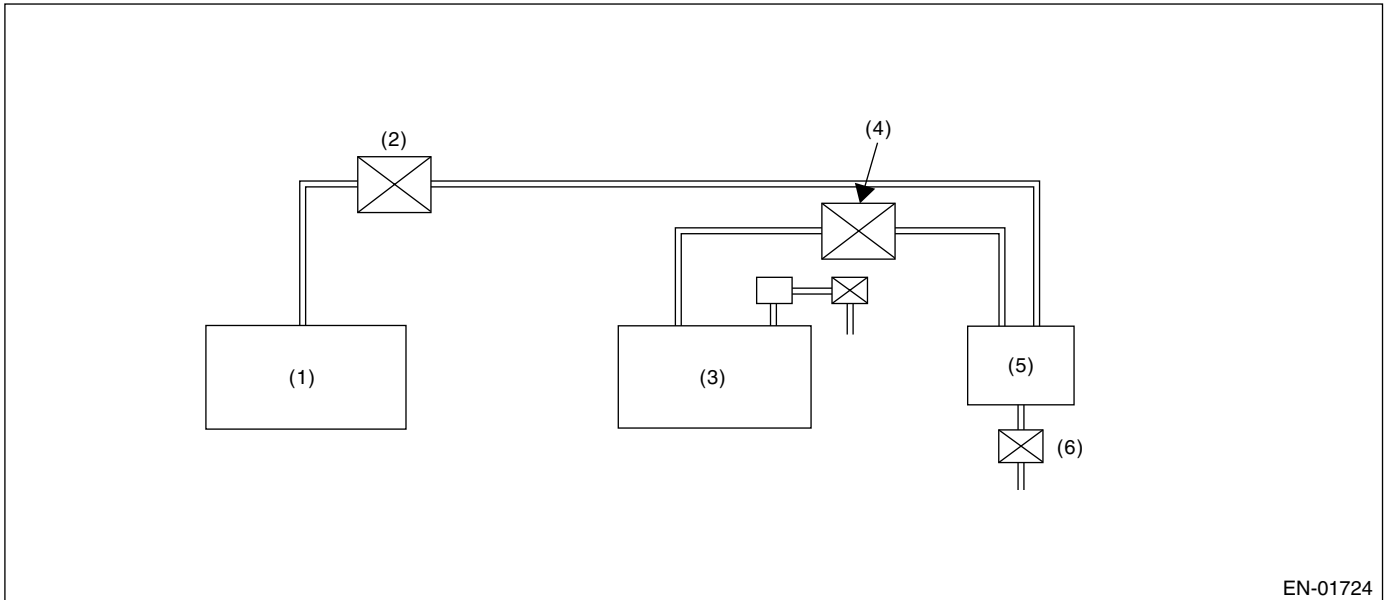

(1) Engine

(2) Purge control solenoid valve

(3) (Open)

(3) Fuel tank

(4) Pressure control solenoid valve

(Close)

(5) Canister

(6) Drain valve (Stuck close)

# DIAGNOSTIC TROUBLE CODE (DTC) DETECTING CRITERIA

GENERAL DESCRIPTION

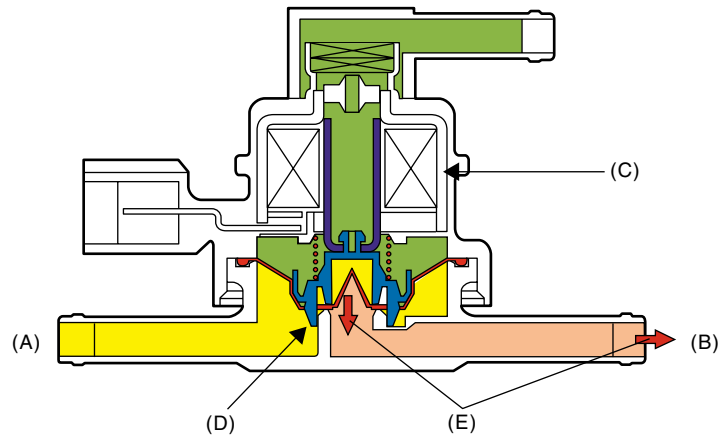

EN-01725

- |                                     |                           |                       |
|-------------------------------------|---------------------------|-----------------------|
| (A) To fuel tank                    | (C) Solenoid ON           | (E) Negative pressure |
| (B) To canister (Negative pressure) | (D) Valve cannot be open. |                       |

## Diagnostic method

CCV closed fixation diagnosis and CPC open fixation diagnosis are performed in mode Z as shown in the figure below.

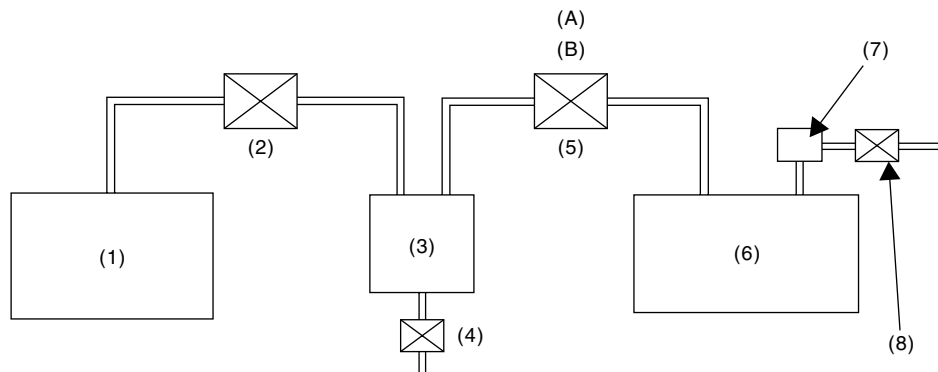

EN-01726

- |                                     |   |  |
|-------------------------------------|---|--|
| (1) Engine                          | (6) Fuel tank                               | (A) At normal: Mechanical control                |
| (2) Purge control solenoid valve    | (7) Fuel tank pressure sensor               | (B) At the time of diagnosis: Electronic control |
| (3) Canister                        | (8) Atmospheric pressure switching solenoid |  |
| (4) Drain valve                     |   |  |
| (5) Pressure control solenoid valve |   |  |

# DIAGNOSTIC TROUBLE CODE (DTC) DETECTING CRITERIA

## GENERAL DESCRIPTION

### • Normal

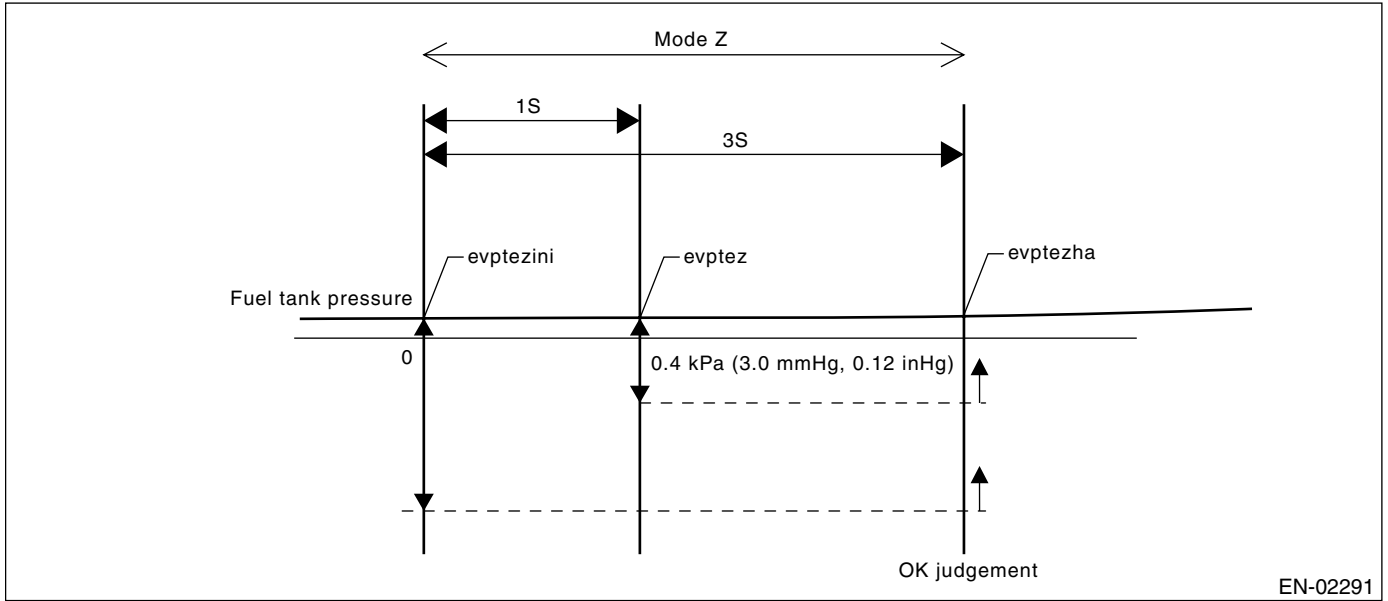

Judge normal when the following conditions are completed at once.

- $evptez - evptezha \leq 0.4 \text{ kPa (3.0 mmHg, 0.12 inHg)}$
- **Purge control solenoid valve open fixation**

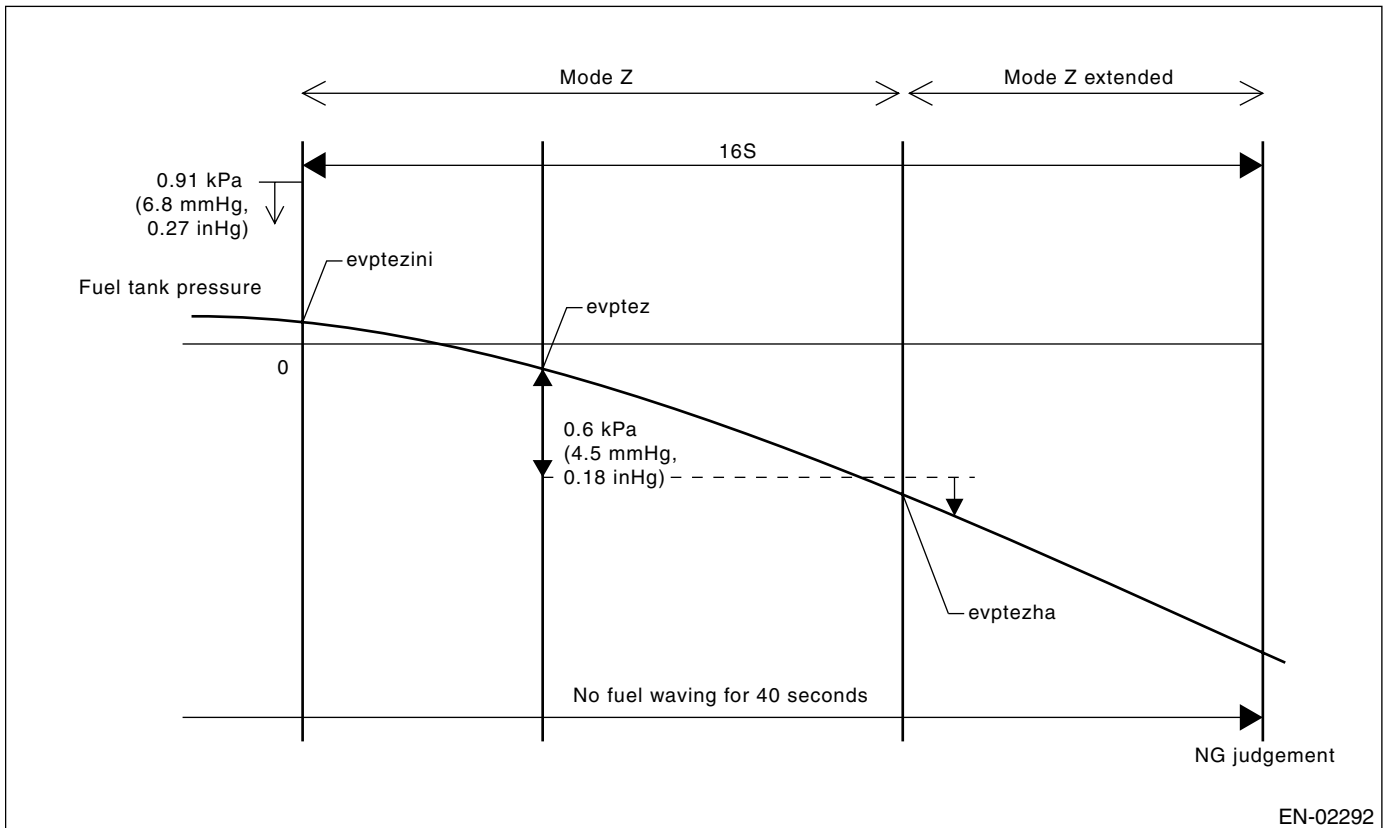

Judge NG when the following conditions are completed at once.

- $evptez - evptezha > 0.6 \text{ kPa (4.5 mmHg, 0.18 inHg)}$
- $evptezini \leq 0.91 \text{ kPa (6.8 mmHg, 0.27 inHg)}$
- Period without 2 L (2.1 US qt, 1.8 Imp qt) or more fuel waving is 40 seconds or more.

# DIAGNOSTIC TROUBLE CODE (DTC) DETECTING CRITERIA

GENERAL DESCRIPTION

## • Diagnosing Function of Purge Control Solenoid Valve [P0457]

By acting as the monitor of the fuel tank pressure in mode Z, functional diagnosis of a purge solenoid valve is performed.

### Normality Judgment

Perform OK judgment in 3 seconds after starting Mode Z and move to Mode A if OK.

Malfunction Criteria	Threshold Value	DTC
(Tank pressure when drain valve opened → closed) – (Tank pressure when terminating Mode Z)	> 0.4 kPa (3 mmHg, 0.12 inHg)	P0457

### Abnormality Judgment

If OK judgment is not possible, prolong Mode Z (16 seconds), and judge NG when all of malfunction criterias are completed after 16 seconds considering the following conditions.

### • Judgment Value

Malfunction Criteria	Threshold Value	DTC
(Tank pressure after 1 second when starting Mode Z) – (Τανκ πρεσσυρε ωηεν χομπλετινγ Μοδε Ζ)	> 0.60 kPa (4.5 mmHg, 0.18 inHg)	P0457
Tank pressure when starting Mode Z	≤ 0.91 kPa (6.8 mmHg, 0.27 inHg)	
Period without 2 $\varnothing$ or more fuel waving	≥ 40 seconds	

**Time Needed for Diagnosis:** 16 seconds

**Malfunction Indicator Light Illumination:** Detect when malfunction occurs in two continuous drive cycles. If the purge control solenoid valve open fixation NG judgment is performed, terminate the EVAP. diagnosis. If OK/NG judgment of the purge control solenoid valve open fixation is not possible in Mode Z, cancel the EVAP. diagnosis.

### • Leakage Diagnosis

#### DTC

P0442 Evaporative Emission Control System Leak Detected (Small Leak)

P0456 Evaporative Emission Control System Leak Detected (Very Small Leak)

P0457 Evaporative Emission Control System Leak Detected (Fuel Cap Loose/Off)

#### Diagnostic Method

The diagnostic method consists of creating a sealed vacuum in the fuel tank and then determining the presence of leakage from the speed at which the tank internal pressure returns to atmospheric pressure.

#### Mode A; (Estimation of evaporation abundance)

The variation amount of this tank pressure P1 calculate. Move to Mode B after calculating P1.

#### Mode B; (Seal negative pressure)

Introduce the negative pressure of the intake manifold into the tank.

Approx. 0 → -1.4 kPa (0 → -10.5 mmHg, 0 → -0.41 inHg) (0.04-inch diagnosis)

Approx. 0 → -3.05 kPa (0 → -22.875 mmHg, 0 → -0.9 inHg) (0.02-inch diagnosis)

Move to Mode C when reaching the pressure above (target pressure).

Then, if the tank pressure does not become negative, judge that there is large leakage in the system. In 0.04-inch diagnosis, judge that there is large leakage in 10 seconds and terminate the EVAP. diagnosis, cancel the diagnosis in 60 seconds. In 0.02-inch diagnosis, cancel the diagnosis in 15 seconds.

### Abnormality Judgment

Judge NG (large leakage) when the malfunction criteria below is completed.

### • Judgment Value

Malfunction Criteria	Threshold Value	DTC
(0.04-inch diagnosis) Mode B period	≥ 10 seconds	P0457
(Tank Pressure Min. Value in Mode B) – (Tank Pressure when starting Mode B)	> 0.3 kPa (2 mmHg, 0.08 inHg)	

# DIAGNOSTIC TROUBLE CODE (DTC) DETECTING CRITERIA

## GENERAL DESCRIPTION

### Mode C; (Check increasing pressure)

Close the purge control solenoid valve and stop the introduction of negative pressure. (Wait until returning to P2 calculation start tank pressure)

When returning to P2 calculation start tank pressure, move to Mode D.

Judge premature OK and move to Mode E when not returning in the determined period of time.

	P2 Calculation Start Tank Pressure	Premature OK Judgment Period
0.04-inch Diagnosis	-1.30 kPa (-9.75 mmHg, -0.38 inHg)	15 seconds
0.02-inch Diagnosis	-3.00 kPa (-22.5 mmHg, -0.89 inHg)	20 seconds

### Mode D; (Measurement of negative pressure variation)

Monitor the tank pressure variation at Mode Z. In this case, the tank pressure increases (close to atmospheric pressure) because the evaporator is generated. However, if there is leakage, the pressure increases additionally. P2 means the variation amount of this tank pressure. After calculating P2, perform the small leakage diagnosis.

#### When Terminating Mode D

By assigning the variation values of tank pressure, P1 and P2, in the following formula, judge the system small leakage. If the calculated judgment value is larger than the threshold value, judge that there is a failure.

0.04-inch Diagnosis

Judge NG when the malfunction criteria below is completed, and judge OK when the malfunction criteria below is not completed.

#### • Judgment Value

Malfunction Criteria	Threshold Value	DTC
$P2 - 1.5 \times P1$ P2: Change of tank pressure within 10 seconds on Mode D  P1: Change of tank pressure within 10 seconds on Mode A	$\geq -0.32 \leftrightarrow 0.53$ kPa (-2.4 $\leftrightarrow$ 4 mmHg, -0.094 $\leftrightarrow$ 0.157 inHg) *Threshold value: Figure (Fuel level vs Tank temperature)	P0442

\*1.5: Compensation value of the amount of evaporator occurrence. (Because evaporator increases more when becoming negative pressure.)

#### • 0.02-inch Diagnosis

#### Abnormality Judgment

Judge NG when the criteria below are completed.

#### • Judgment Value

Malfunction Criteria	Threshold Value	DTC
$P2 - 1.5 \times P1$ P2: Change of tank pressure within 22 seconds on Mode D P1: Change of tank pressure within 22 seconds on Mode A	$>$ Value on Map 8. *Threshold value: Figure (Fuel level vs Tank temperature)	P0456



# DIAGNOSTIC TROUBLE CODE (DTC) DETECTING CRITERIA

GENERAL DESCRIPTION

## • Map 8 Limit of malfunction criteria for 0.02-inch leak as Evap. diagnosis.

Fuel temperature & Fuel level	30°C (86°F)	35°C (95°F)	40°C (104°F)	45°C (113°F)
10 L (2.6 US gal, 2.2 Imp gal)	0.32 kPa (2.39 mmHg, 0.094 inHg)	0.37 kPa (2.77 mmHg, 0.109 inHg)	0.42 kPa (3.16 mmHg, 0.124 inHg)	0.47 kPa (3.55 mmHg, 0.140 inHg)
20 L (5.3 US gal, 4.4 Imp gal)	0.36 kPa (2.68 mmHg, 0.106 inHg)	0.41 kPa (3.04 mmHg, 0.120 inHg)	0.45 kPa (3.4 mmHg, 0.134 inHg)	0.50 kPa (3.77 mmHg, 0.148 inHg)
30 L (7.9 US gal, 6.6 Imp gal)	0.39 kPa (2.96 mmHg, 0.177 inHg)	0.44 kPa (3.3 mmHg, 0.130 inHg)	0.49 kPa (3.64 mmHg, 0.143 inHg)	0.53 kPa (3.98 mmHg, 0.157 inHg)
40 L (10.6 US gal, 8.8 Imp gal)	0.43 kPa (3.2 mmHg, 0.126 inHg)	0.48 kPa (3.58 mmHg, 0.141 inHg)	0.53 kPa (3.96 mmHg, 0.156 inHg)	0.58 kPa (4.35 mmHg, 0.171 inHg)
50 L (13.2 US gal, 11.0 Imp gal)	0.46 kPa (3.43 mmHg, 0.135 inHg)	0.51 kPa (3.86 mmHg, 0.151 inHg)	0.57 kPa (4.28 mmHg, 0.169 inHg)	0.63 kPa (4.71 mmHg, 0.185 inHg)

### Normality Judgment

Judge OK when the criteria below are completed.

#### • Judgment Value

Malfunction Criteria	Threshold Value	DTC
P2 – 1.5 × P1	< Valve on Map 9.	P0456

## • Map 9.

Fuel temperature & Fuel level	30°C (86°F)	35°C (95°F)	40°C (104°F)	45°C (113°F)
10 L (2.6 US gal, 2.2 Imp gal)	0.21 kPa (1.59 mmHg, 0.063 inHg)	0.26 kPa (1.97 mmHg, 0.078 inHg)	0.31 kPa (2.36 mmHg, 0.093 inHg)	0.37 kPa (2.74 mmHg, 0.107 inHg)
20 L (5.3 US gal, 4.4 Imp gal)	0.28 kPa (2.09 mmHg, 0.082 inHg)	0.33 kPa (2.45 mmHg, 0.096 inHg)	0.37 kPa (2.81 mmHg, 0.111 inHg)	0.42 kPa (3.17 mmHg, 0.125 inHg)
30 L (7.9 US gal, 6.6 Imp gal)	0.35 kPa (2.59 mmHg, 0.102 inHg)	0.39 kPa (2.92 mmHg, 0.115 inHg)	0.43 kPa (3.26 mmHg, 0.128 inHg)	0.48 kPa (3.59 mmHg, 0.141 inHg)
40 L (10.6 US gal, 8.8 Imp gal)	0.27 kPa (2.01 mmHg, 0.079 inHg)	0.32 kPa (2.39 mmHg, 0.094 inHg)	0.37 kPa (2.77 mmHg, 0.109 inHg)	0.42 kPa (3.15 mmHg, 0.124 inHg)
50 L (13.2 US gal, 11.0 Imp gal)	0.19 kPa (1.43 mmHg, 0.056 inHg)	0.18 kPa (1.36 mmHg, 0.054 inHg)	0.30 kPa (2.28 mmHg, 0.090 inHg)	0.36 kPa (2.71 mmHg, 0.107 inHg)

If OK/NG judgment is not possible, repeat the diagnosis.

# DIAGNOSTIC TROUBLE CODE (DTC) DETECTING CRITERIA

## GENERAL DESCRIPTION

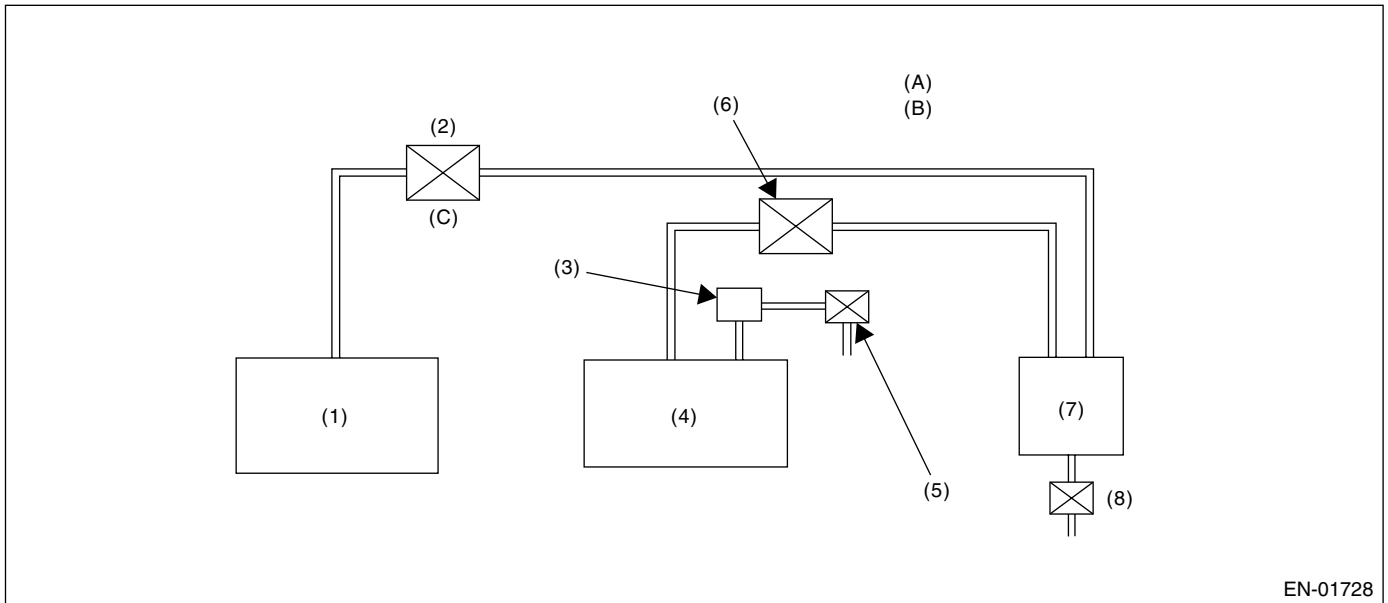

- |                                  |   |  |
|----------------------------------|---|--|
| (1) Engine                       | (5) Atmospheric pressure switching solenoid | (8) Drain valve                                  |
| (2) Purge control solenoid valve | (6) Pressure control solenoid valve         | (A) At normal: Mechanical control                |
| (3) Fuel tank pressure sensor    | (7) Canister                                | (B) At the time of diagnosis: Electronic control |
| (4) Fuel tank                    |   |  |

### • 0.04-inch Diagnosis

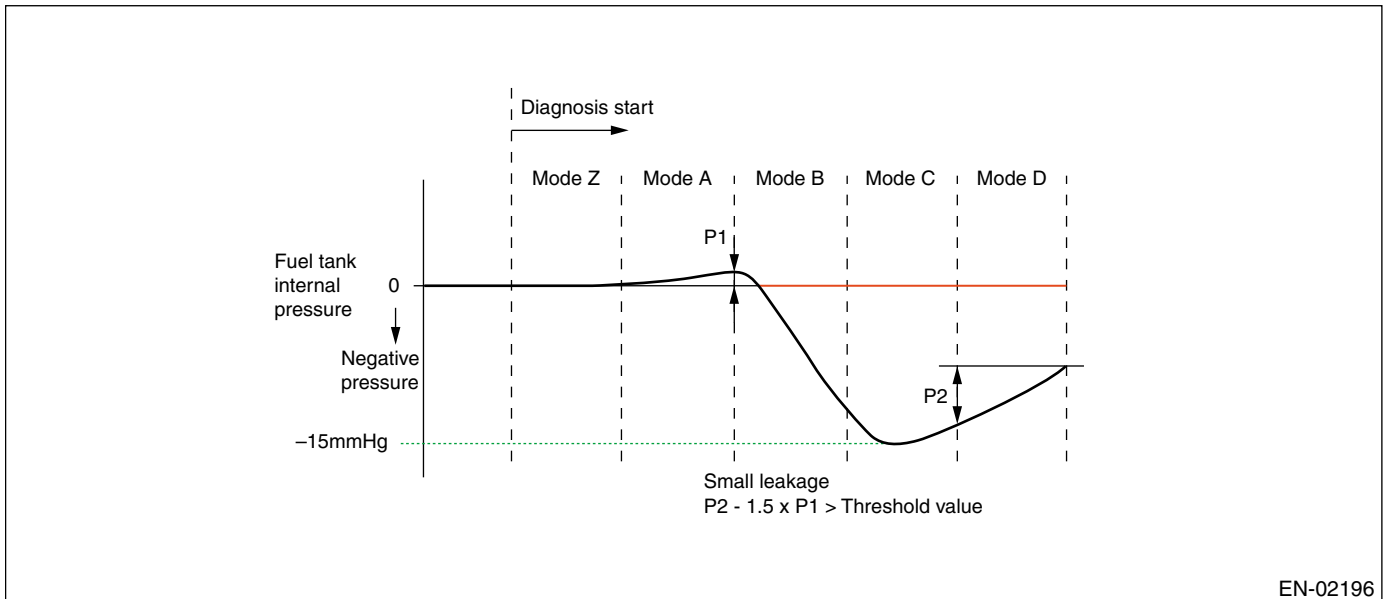

#### Time Needed for Diagnosis:

- |            |                   |
|------------|-------------------|
| 0.04-inch: | 30 to 100 seconds |
| 0.02-inch: | 80 to 100 seconds |

**Malfunction Indicator Light Illumination:** Detect when malfunction occurs in two continuous drive cycles.

### 6. DTC CLEAR CONDITION

- When the OK idling cycle was completed 40 times in a row
- When "Clear Memory" was performed

# DIAGNOSTIC TROUBLE CODE (DTC) DETECTING CRITERIA

GENERAL DESCRIPTION

---

## 7. MALFUNCTION INDICATOR LIGHT CLEAR CONDITION

- When the OK driving cycle was completed 3 times in a row
- When "Clear Memory" was performed

## 8. FAIL SAFE

None

## 9. ECM OPERATION AT DTC SETTING

- Memorize the freeze frame data. (For test mode \$02)
- Memorize the diagnostic value and trouble standard value. (For test mode \$06)

# DIAGNOSTIC TROUBLE CODE (DTC) DETECTING CRITERIA

## GENERAL DESCRIPTION

### BE:DTC P0447 — EVAPORATIVE EMISSION CONTROL SYSTEM VENT CONTROL CIRCUIT OPEN —

#### 1. OUTLINE OF DIAGNOSIS

Detect the open or short circuit of drain valve.

Judge NG when the ECM output level is different from the actual terminal level.

#### 2. COMPONENT DESCRIPTION

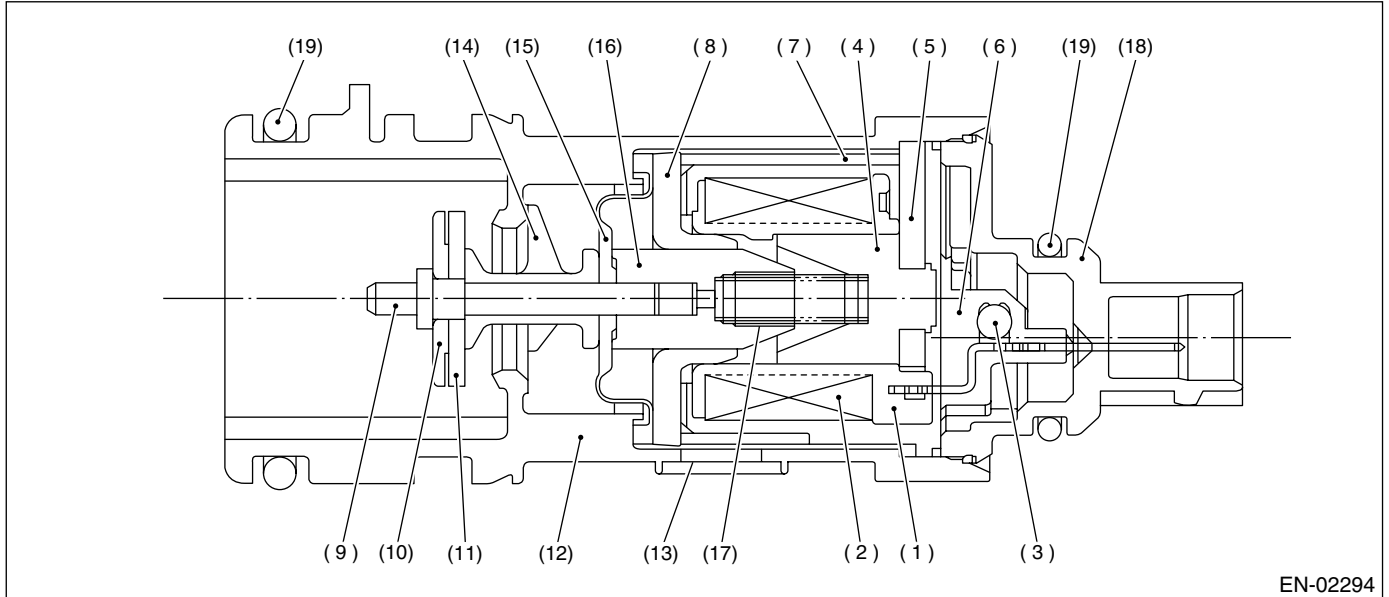

EN-02294

- |                 |                    |                   |
|-----------------|--------------------|-------------------|
| (1) Bobbin      | (8) Magnetic plate | (15) Diaphragm    |
| (2) Coil        | (9) Shaft          | (16) Movable core |
| (3) Diode       | (10) Plate         | (17) Spring       |
| (4) Stator core | (11) Valve         | (18) Cover        |
| (5) End plate   | (12) Housing       | (19) O-ring       |
| (6) Body        | (13) Filter        |                   |
| (7) Yoke        | (14) Retainer      |                   |

#### 3. ENABLE CONDITION

Secondary Parameters	Enable Conditions
None	

#### 4. GENERAL DRIVING CYCLE

Always perform the diagnosis continuously.

# DIAGNOSTIC TROUBLE CODE (DTC) DETECTING CRITERIA

GENERAL DESCRIPTION

## 5. DIAGNOSTIC METHOD

### • Abnormality Judgment

Judge NG when the continuous time of completing the malfunction criteria below becomes more than 2.5 seconds.

### • Judgment Value

Malfunction Criteria	Threshold Value
Ignition switch	ON
Battery voltage	$\geq 10.9$ V
After engine starting	1 second or more
Terminal output voltage when ECM sends OFF signal	Low

**Time Needed for Diagnosis:** 2.5 seconds

**Malfunction Indicator Light Illumination:** Illuminates as soon as the malfunction occurs.

### • Normality Judgment

Judge OK and clear the NG when the malfunction criteria below are completed.

### • Judgment Value

Malfunction Criteria	Threshold Value
Ignition switch	ON
Battery voltage	$\geq 10.9$ V
After engine starting	1 second or more
Terminal output voltage when ECM sends OFF signal	High

## 6. DTC CLEAR CONDITION

- When the OK idling cycle was completed 40 times in a row
- When "Clear Memory" was performed

## 7. MALFUNCTION INDICATOR LIGHT CLEAR CONDITION

- When the OK driving cycle was completed 3 times in a row
- When "Clear Memory" was performed

## 8. FAIL SAFE

PCV control: Open the PCV solenoid.

## 9. ECM OPERATION AT DTC SETTING

Memorize the freeze frame data. (For test mode \$02)

# DIAGNOSTIC TROUBLE CODE (DTC) DETECTING CRITERIA

## GENERAL DESCRIPTION

### BF:DTC P0448 — EVAPORATIVE EMISSION CONTROL SYSTEM VENT CONTROL CIRCUIT SHORTED —

#### 1. OUTLINE OF DIAGNOSIS

Detect the open or short circuit of drain valve.

Judge NG when the ECM output level is different from the actual terminal level.

#### 2. COMPONENT DESCRIPTION

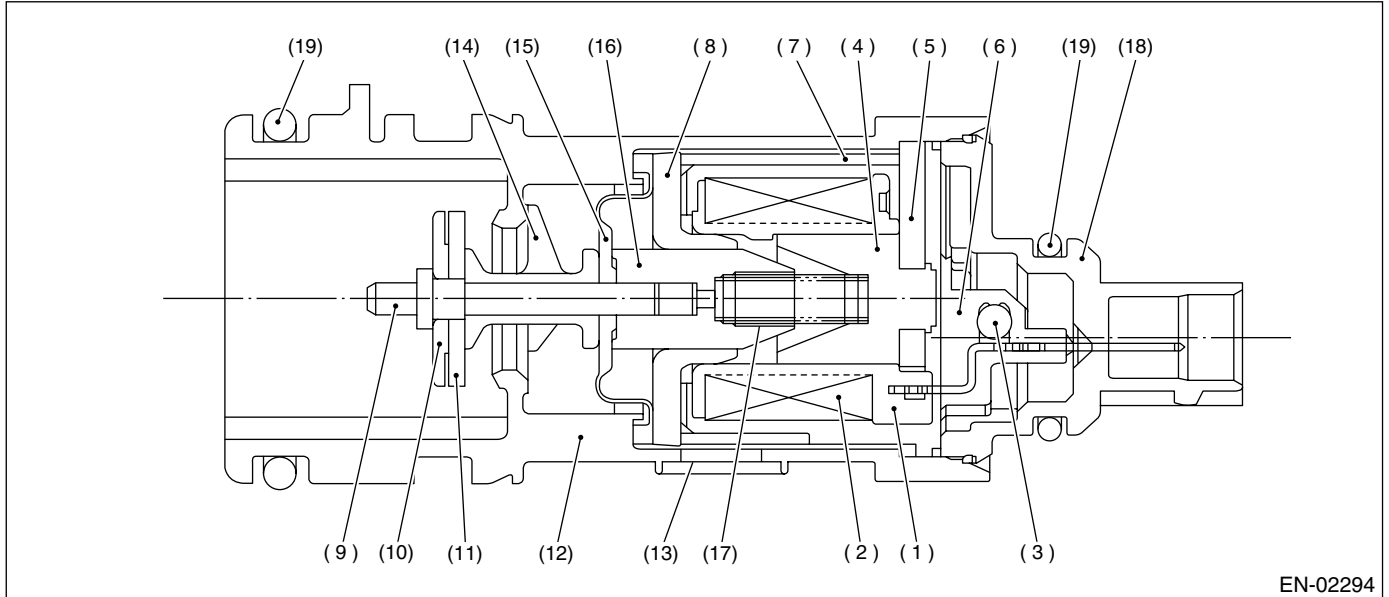

EN-02294

- |                 |                    |                   |
|-----------------|--------------------|-------------------|
| (1) Bobbin      | (8) Magnetic plate | (15) Diaphragm    |
| (2) Coil        | (9) Shaft          | (16) Movable core |
| (3) Diode       | (10) Plate         | (17) Spring       |
| (4) Stator core | (11) Valve         | (18) Cover        |
| (5) End plate   | (12) Housing       | (19) O-ring       |
| (6) Body        | (13) Filter        |                   |
| (7) Yoke        | (14) Retainer      |                   |

#### 3. ENABLE CONDITION

Secondary Parameters	Enable Conditions
None	

#### 4. GENERAL DRIVING CYCLE

Always perform the diagnosis continuously.

# DIAGNOSTIC TROUBLE CODE (DTC) DETECTING CRITERIA

GENERAL DESCRIPTION

## 5. DIAGNOSTIC METHOD

### • Abnormality Judgment

Judge NG when the continuous time of completing the malfunction criteria below becomes more than 2.5 seconds.

### • Judgment Value

Malfunction Criteria	Threshold Value
Ignition switch	ON
Battery voltage	$\geq 10.9$ V
After engine starting	1 second or more
Terminal output voltage when ECM sends ON signal	High

**Time Needed for Diagnosis:** 2.5 seconds

**Malfunction Indicator Light Illumination:** Illuminates as soon as the malfunction occurs.

### • Normality Judgment

Judge OK and clear the NG when the malfunction criteria below are completed.

### • Judgment Value

Malfunction Criteria	Threshold Value
Ignition switch	ON
Battery voltage	$\geq 10.9$ V
After engine starting	1 second or more
Terminal output voltage when ECM sends ON signal	Low

## 6. DTC CLEAR CONDITION

- When the OK idling cycle was completed 40 times in a row
- When "Clear Memory" was performed

## 7. MALFUNCTION INDICATOR LIGHT CLEAR CONDITION

- When the OK driving cycle was completed 3 times in a row
- When "Clear Memory" was performed

## 8. FAIL SAFE

PCV control: Open the PCV solenoid.

## 9. ECM OPERATION AT DTC SETTING

Memorize the freeze frame data. (For test mode \$02)

# DIAGNOSTIC TROUBLE CODE (DTC) DETECTING CRITERIA

## GENERAL DESCRIPTION

### BG:DTC P0451 — EVAPORATIVE EMISSION CONTROL SYSTEM PRESSURE SENSOR RANGE/PERFORMANCE —

#### 1. OUTLINE OF DIAGNOSIS

Detect the tank pressure sensor output property abnormality.

Judge NG when there is no pressure variation, which should exist in the tank, considering the engine status.

#### 2. COMPONENT DESCRIPTION

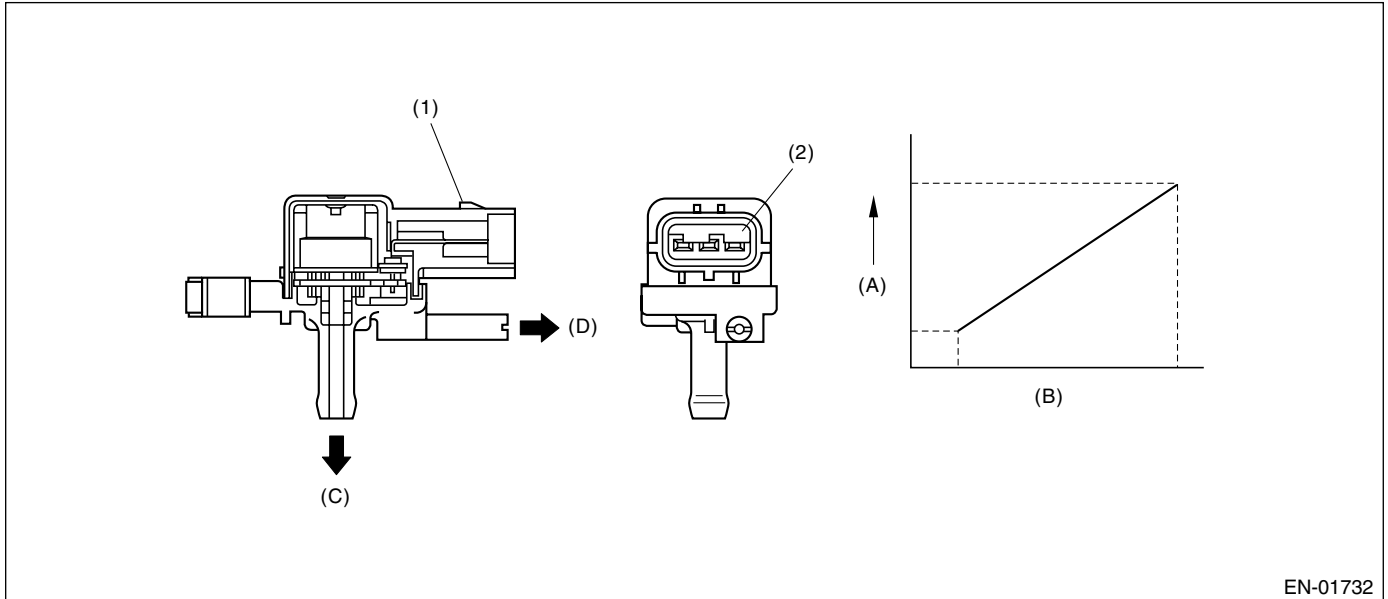

EN-01732

(1) Connector

(2) Terminal

(A) Output voltage

(B) Input voltage

(C) To fuel tank

(D) To atmospheric pressure switching solenoid

#### 3. ENABLE CONDITION

Secondary Parameters	Enable Conditions
ON/OFF change of EVAP canister purge	Experienced
After starting the engine	60 second or more
Fuel level	$\geq 18 \text{ l}$ (4.76 US gal, 3.96 Imp gal)
Fuel temperature	$< 35^{\circ}\text{C}$ ( $95^{\circ}\text{F}$ )
Battery voltage	$\geq 10.9 \text{ V}$
Atmospheric pressure	$> 75.1 \text{ kPa}$ (563 mmHg, 22.2 inHg)
Engine speed	$< 3000 \text{ rpm}$

#### 4. GENERAL DRIVING CYCLE

- Perform the diagnosis continuously in 60 seconds or more after starting the engine.
- Be sure to check the fuel level and fuel temperature.



# DIAGNOSTIC TROUBLE CODE (DTC) DETECTING CRITERIA

GENERAL DESCRIPTION

## 5. DIAGNOSTIC METHOD

### • Abnormality Judgment

Judge NG when the malfunction criteria below is completed.

### • Judgment Value

Malfunction Criteria	Threshold Value
Number of times when the difference between the Max. fuel level and the Min., fuel level every 60 seconds is 5 ℓ (1.3 US gal, 1.1 Imp gal) or more (with enable condition completed)	≥ 16 times
Max. – Min. tank pressure (with enable condition completed)	< 0.05 kPa (0.375 mmHg, 0.02 inHg)
Max. – Min. fuel temperature (with enable condition completed)	≥ 7°C (44.6 °F)

If the fuel level (Max. – Min.) in every 60 seconds is less than 5 ℓ (1.3 US gal, 1.1 Imp gal), extend 60 seconds more and make judgment with the Max. and Min. fuel level in 120 seconds.

If the difference did not appear though the time extended, extend the time (180, 240, 300 seconds) and continue the judgment.

Diagnosis counter will count up when the difference of fuel level (Max. – Min.) is more than 5 ℓ (1.3 US gal, 1.1 Imp gal).

**Time Needed for Diagnosis:** 60 seconds × 16 times or more

**Malfunction Indicator Light Illumination:** Illuminates when malfunction occurs in two continuous drive cycles.

### • Normality Judgment

Judge OK when the malfunction criteria below is completed.

### • Judgment Value

Malfunction Criteria	Threshold Value
Max. – Min. tank pressure	≥ 0.05 kPa (0.375 mmHg, 0.02 inHg)

## 6. DTC CLEAR CONDITION

- When the OK idling cycle was completed 40 times in a row
- When “Clear Memory” was performed

## 7. MALFUNCTION INDICATOR LIGHT CLEAR CONDITION

- When the OK driving cycle was completed 3 times in a row
- When “Clear Memory” was performed

## 8. FAIL SAFE

Purge control solenoid valve control: Purge fixation mode is prohibited.

## 9. ECM OPERATION AT DTC SETTING

Memorize the freeze frame data. (For test mode \$02)

# DIAGNOSTIC TROUBLE CODE (DTC) DETECTING CRITERIA

## GENERAL DESCRIPTION

### BH:DTC P0452 — EVAPORATIVE EMISSION CONTROL SYSTEM PRESSURE SENSOR LOW INPUT —

#### 1. OUTLINE OF DIAGNOSIS

Detect the open or short circuit of the fuel tank pressure sensor.  
Judge NG when out of the standard value.

#### 2. COMPONENT DESCRIPTION

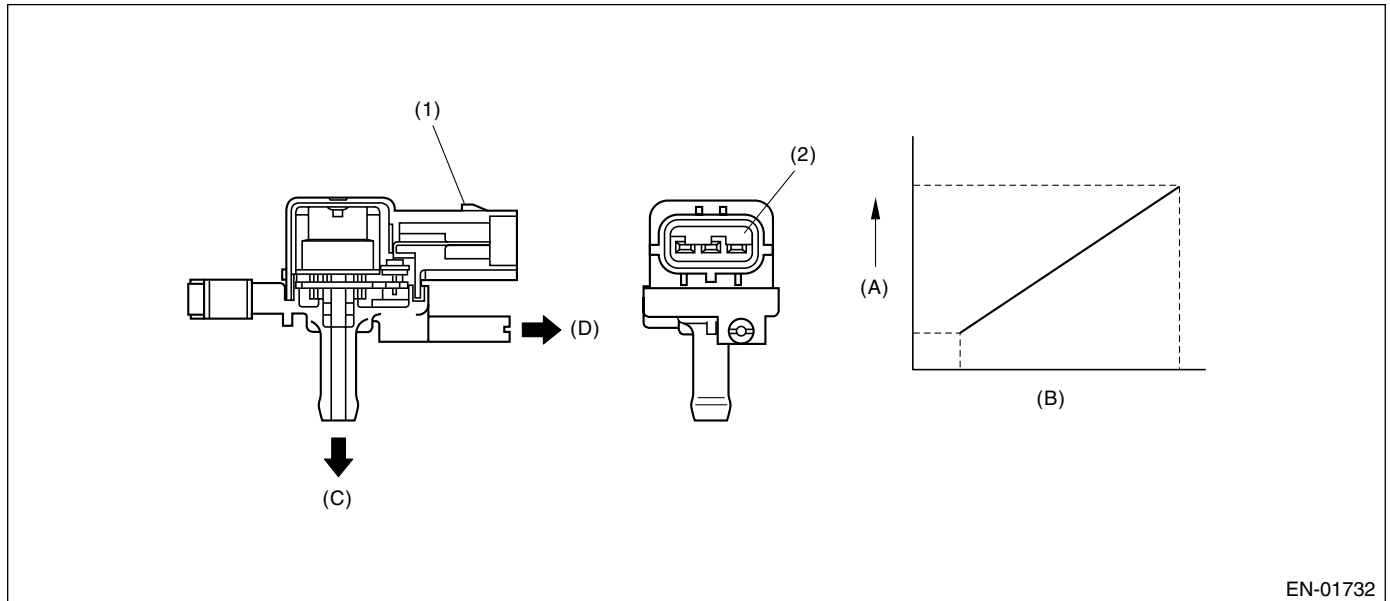

EN-01732

(1) Connector

(2) Terminal

(A) Output voltage

(B) Input voltage

(C) To fuel tank

(D) To atmospheric pressure switching solenoid

#### 3. ENABLE CONDITION

Secondary Parameters	Enable Conditions
None	

#### 4. GENERAL DRIVING CYCLE

Always perform the diagnosis continuously.

# DIAGNOSTIC TROUBLE CODE (DTC) DETECTING CRITERIA

GENERAL DESCRIPTION

## 5. DIAGNOSTIC METHOD

### • Abnormality Judgment

Judge NG when the continuous time of completing the malfunction criteria below becomes more than 15 seconds.

### • Judgment Value

Malfunction Criteria	Threshold Value
Fuel tank pressure	< -7.3 kPa (-55 mmHg, -2.17 inHg)
Battery voltage	≥ 10.9 V

**Time Needed for Diagnosis:** 15 seconds

**Malfunction Indicator Light Illumination:** Illuminates as soon as malfunction occurs.

### • Normality Judgment

Judge OK when the malfunction criteria below is completed.

### • Judgment Value

Malfunction Criteria	Threshold Value
Fuel tank pressure	< -7.3 kPa (-55 mmHg, -2.17 inHg)
Battery voltage	≥ 10.9 V

## 6. DTC CLEAR CONDITION

- When the OK idling cycle was completed 40 times in a row
- When "Clear Memory" was performed

## 7. MALFUNCTION INDICATOR LIGHT CLEAR CONDITION

- When the OK driving cycle was completed 3 times in a row
- When "Clear Memory" was performed

## 8. FAIL SAFE

Purge control solenoid valve control: Purge fixation mode is prohibited.

## 9. ECM OPERATION AT DTC SETTING

Memorize the freeze frame data. (For test mode \$02)

# DIAGNOSTIC TROUBLE CODE (DTC) DETECTING CRITERIA

## GENERAL DESCRIPTION

### BI: DTC P0453 — EVAPORATIVE EMISSION CONTROL SYSTEM PRESSURE SENSOR HIGH INPUT —

#### 1. OUTLINE OF DIAGNOSIS

Detect the breaking/shortage of the fuel tank pressure sensor.  
Judge NG when out of the standard value.

#### 2. COMPONENT DESCRIPTION

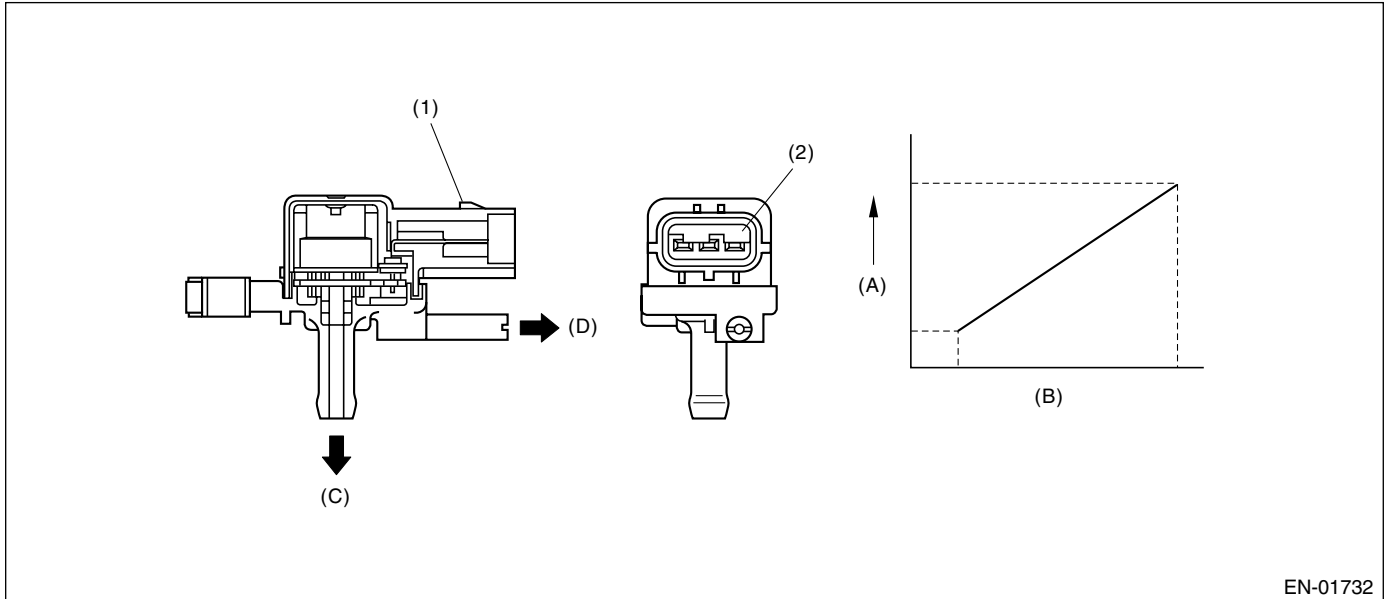

EN-01732

(1) Connector

(2) Terminal

(A) Output voltage

(B) Input voltage

(C) To fuel tank

(D) To atmospheric pressure switching solenoid

#### 3. ENABLE CONDITION

Secondary Parameters	Enable Conditions
Vehicle speed	$\geq 2$ km/h (1.24 MPH)
All conditions of EVAP canister purge	Complete
Evaporation gas density learning value (both left and right)	$< 0.08$
Main feedback compensation coefficient (both left and right)	$\geq 0.9$
Battery voltage	$\geq 10.9$ V

#### 4. GENERAL DRIVING CYCLE

Perform the diagnosis when purging.

# DIAGNOSTIC TROUBLE CODE (DTC) DETECTING CRITERIA

GENERAL DESCRIPTION

## 5. DIAGNOSTIC METHOD

### • Abnormality Judgment

Judge NG when the continuous time until completing the malfunction criteria below becomes more than 15 seconds.

### • Judgment Value

Malfunction Criteria	Threshold Value
Fuel tank pressure	$\geq 7.3$ kPa (55 mmHg, 2.17 inHg)
Fuel temperature	$< 35^{\circ}\text{C}$ (95 $^{\circ}\text{F}$ )

**Time Needed for Diagnosis:** 15 seconds

**Malfunction Indicator Light Illumination:** Illuminates as soon as malfunction occurs.

### • Normality Judgment

Judge OK when the malfunction criteria below is completed.

### • Judgment Value

Malfunction Criteria	Threshold Value
Fuel tank pressure	$\geq 7.3$ kPa (55 mmHg, 2.17 inHg)

## 6. DTC CLEAR CONDITION

- When the OK idling cycle was completed 40 times in a row
- When "Clear Memory" was performed

## 7. MALFUNCTION INDICATOR LIGHT CLEAR CONDITION

- When the OK driving cycle was completed 3 times in a row
- When "Clear Memory" was performed

## 8. FAIL SAFE

Purge control solenoid valve control: Purge fixation mode is prohibited.

## 9. ECM OPERATION AT DTC SETTING

Memorize the freeze frame data. (For test mode \$02)

# DIAGNOSTIC TROUBLE CODE (DTC) DETECTING CRITERIA

## GENERAL DESCRIPTION

---

### **BJ:DTC P0456 — EVAPORATIVE EMISSION CONTROL SYSTEM LEAK DETECTED (VERY SMALL LEAK) —**

#### **1. OUTLINE OF DIAGNOSIS**

For detecting conditions, refer to DTC P0442 EVAPORATIVE EMISSION CONTROL SYSTEM LEAK DETECTED (SMALL LEAK). <Ref. to GD(H6DO)-120, DTC P0442 — EVAPORATIVE EMISSION CONTROL SYSTEM LEAK DETECTED (SMALL LEAK) —, Diagnostic Trouble Code (DTC) Detecting Criteria.>

### **BK:DTC P0457 — EVAPORATIVE EMISSION CONTROL SYSTEM LEAK DETECTED (FUEL CAP LOOSE/OFF) —**

#### **1. OUTLINE OF DIAGNOSIS**

For detecting conditions, refer to DTC P0442 EVAPORATIVE EMISSION CONTROL SYSTEM LEAK DETECTED (SMALL LEAK). <Ref. to GD(H6DO)-120, DTC P0442 — EVAPORATIVE EMISSION CONTROL SYSTEM LEAK DETECTED (SMALL LEAK) —, Diagnostic Trouble Code (DTC) Detecting Criteria.>

**DIAGNOSTIC TROUBLE CODE (DTC) DETECTING CRITERIA**

GENERAL DESCRIPTION

---

**MEMO:**

# DIAGNOSTIC TROUBLE CODE (DTC) DETECTING CRITERIA

## GENERAL DESCRIPTION

### BL:DTC P0458 — EVAPORATIVE EMISSION CONTROL SYSTEM PURGE CONTROL VALVE CIRCUIT LOW —

#### 1. OUTLINE OF DIAGNOSIS

Detect open or short circuit of purge control solenoid valve.  
Judge NG when ECM output level is different from actual terminal level.

#### 2. COMPONENT DESCRIPTION

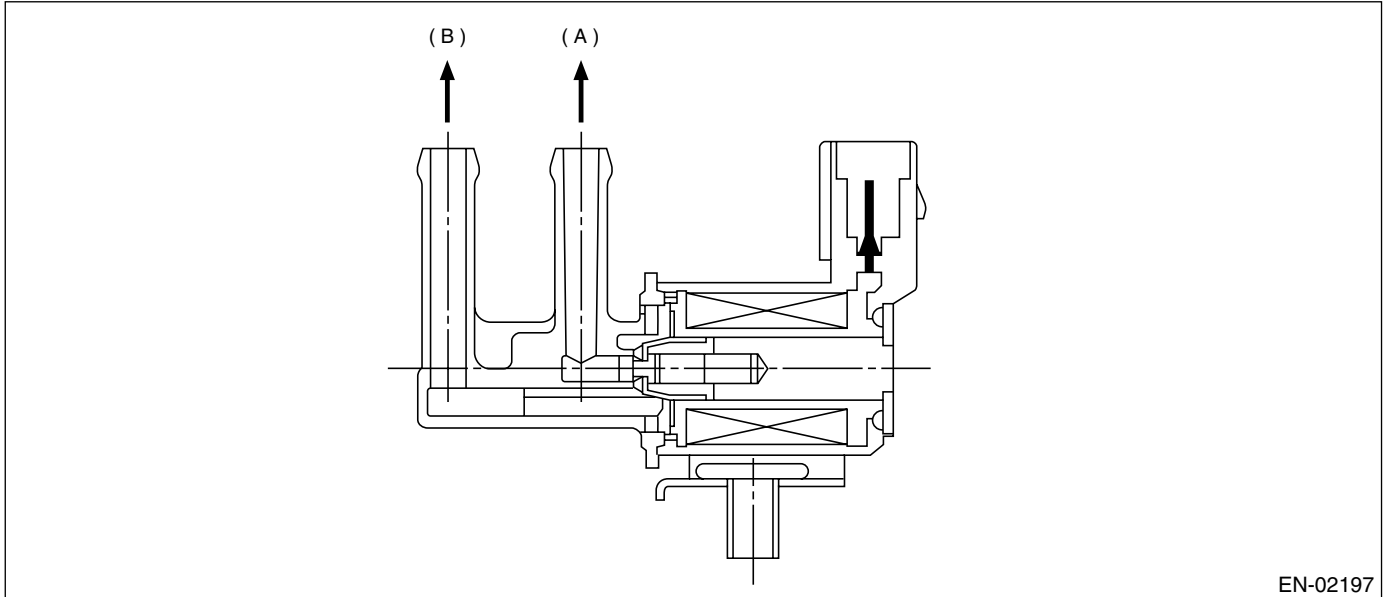

(A) To canister

(B) To intake manifold

#### 3. ENABLE CONDITION

Secondary Parameters	Enable Conditions
Ignition switch	ON
Battery voltage	$\geq 10.9$ V
After engine starting	1 second or more

#### 4. GENERAL DRIVING CYCLE

Always perform the diagnosis after starting the engine.



# DIAGNOSTIC TROUBLE CODE (DTC) DETECTING CRITERIA

GENERAL DESCRIPTION

## 5. DIAGNOSTIC METHOD

### • Abnormality Judgment

Judge NG when the malfunction criteria below becomes.

### • Judgment Value

Malfunction Criteria	Threshold Value
Duty ratio of 'ON'	< 75%
Terminal output voltage	Low

**Time Needed for Diagnosis:** 2.5 seconds

**Malfunction Indicator Light Illumination:** Illuminates when malfunction occurs in 2 continuous driving cycles.

### • Normality Judgment

Judge OK and clear NG when the malfunction criterion below is completed.

### • Judgment Value

Malfunction Criteria	Threshold Value
Terminal output voltage	High

## 6. DTC CLEAR CONDITION

- When the OK idling cycle was completed 40 times in a row
- When "Clear Memory" was performed

## 7. MALFUNCTION INDICATOR LIGHT CLEAR CONDITION

- When the OK driving cycle was completed 3 times in a row
- When "Clear Memory" was performed

## 8. FAIL SAFE

None

## 9. ECM OPERATION AT DTC SETTING

Memorize the freeze frame data. (For test mode \$02)

# DIAGNOSTIC TROUBLE CODE (DTC) DETECTING CRITERIA

## GENERAL DESCRIPTION

### BM:DTC P0459 — EVAPORATIVE EMISSION CONTROL SYSTEM PURGE CONTROL VALVE CIRCUIT HIGH —

#### 1. OUTLINE OF DIAGNOSIS

Detect open or short circuit of purge control solenoid valve.  
Judge NG when ECM output level is different from actual terminal level.

#### 2. COMPONENT DESCRIPTION

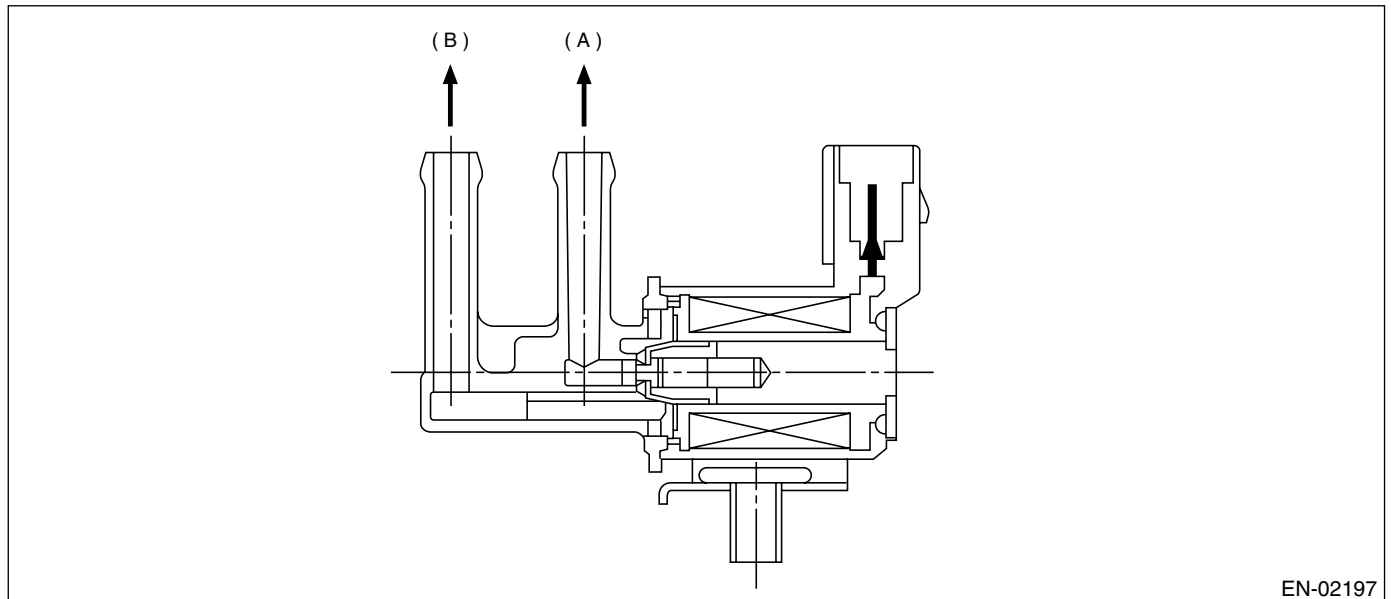

(A) To canister

(B) To intake manifold

#### 3. ENABLE CONDITION

Secondary Parameters	Enable Conditions
Ignition switch	ON
Battery voltage	$\geq 10.9$ V
After engine starting	1 second or more

#### 4. GENERAL DRIVING CYCLE

Always perform the diagnosis after starting the engine.

# DIAGNOSTIC TROUBLE CODE (DTC) DETECTING CRITERIA

GENERAL DESCRIPTION

## 5. DIAGNOSTIC METHOD

### • Abnormality Judgment

Judge NG when the continuous time of completing the malfunction criteria below becomes more than the time needed for diagnosis (2.5 seconds).

### • Judgment Value

Malfunction Criteria	Threshold Value
Duty ratio of 'ON'	≥ 25%
Terminal output voltage	High

**Time Needed for Diagnosis:** 2.5 seconds

**Malfunction Indicator Light Illumination:** Illuminates when malfunction occurs in 2 continuous driving cycles.

### • Normality Judgment

Judge OK and clear NG when the malfunction criterion below is completed.

### • Judgment Value

Malfunction Criteria	Threshold Value
Terminal output voltage	Low

## 6. DTC CLEAR CONDITION

- When the OK idling cycle was completed 40 times in a row
- When "Clear Memory" was performed

## 7. MALFUNCTION INDICATOR LIGHT CLEAR CONDITION

- When the OK driving cycle was completed 3 times in a row
- When "Clear Memory" was performed

## 8. FAIL SAFE

None

## 9. ECM OPERATION AT DTC SETTING

Memorize the freeze frame data. (For test mode \$02)

# DIAGNOSTIC TROUBLE CODE (DTC) DETECTING CRITERIA

## GENERAL DESCRIPTION

### BN:DTC P0461 — FUEL LEVEL SENSOR CIRCUIT RANGE/PERFORMANCE —

#### 1. OUTLINE OF DIAGNOSIS

Detect the malfunction of fuel level sensor output property.

Judge NG when the fuel level does not vary whereas it seemed to vary be in a usual driving speed.

#### 2. COMPONENT DESCRIPTION

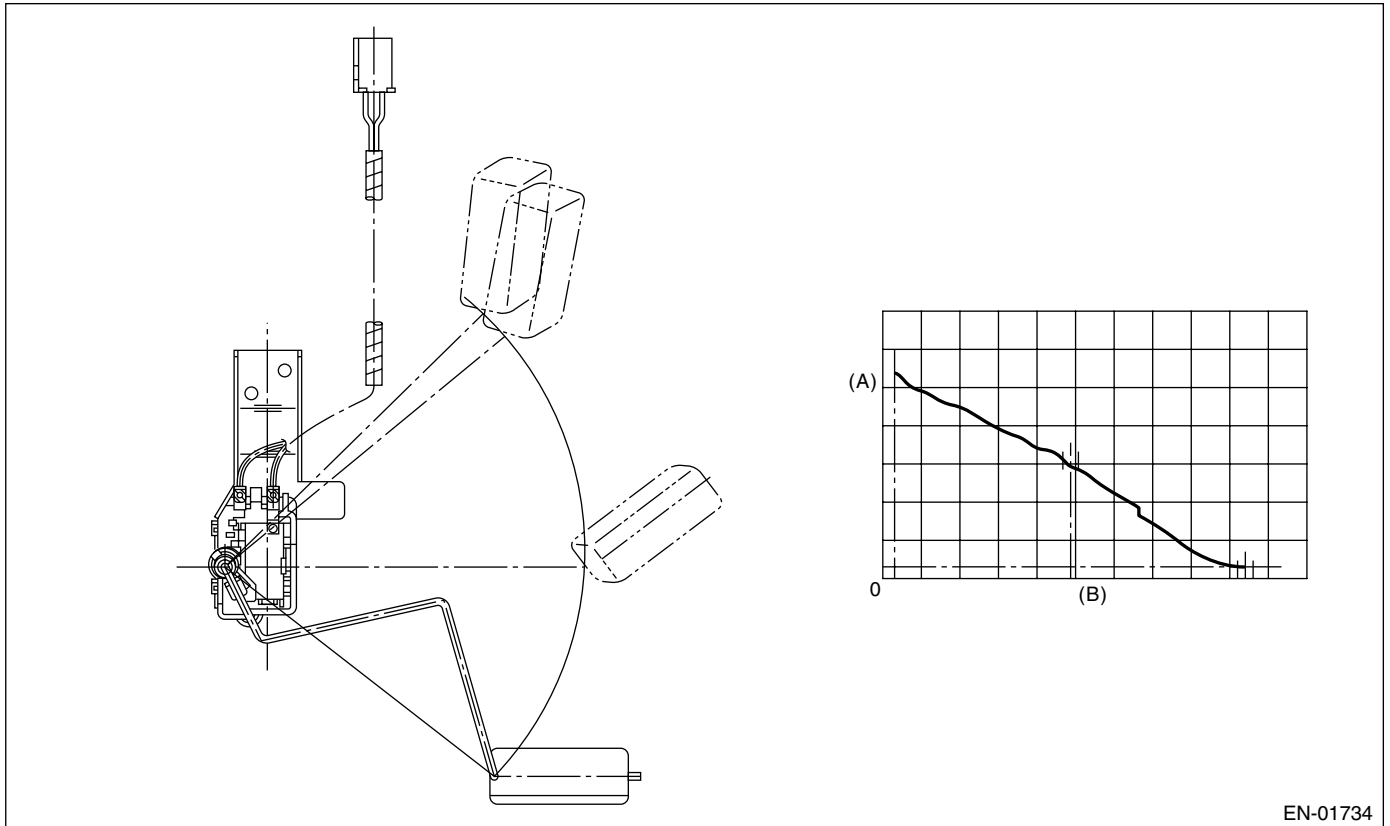

EN-01734

(A) Fuel level

(B) Resistance

#### 3. ENABLE CONDITION

Secondary Parameters	Enable Conditions
None	

#### 4. GENERAL DRIVING CYCLE

Always perform the diagnosis continuously.

# DIAGNOSTIC TROUBLE CODE (DTC) DETECTING CRITERIA

GENERAL DESCRIPTION

## 5. DIAGNOSTIC METHOD

### • Abnormality Judgment

Judge NG when the malfunction criteria below are completed.

### • Judgment Value

Malfunction Criteria	Threshold Value
Accumulated amount of intake air	> 331 kg (729.7 lb)
Max.– Min. fuel level output	< 2.6 ℓ (0.69 US gal, 0.57 Imp gal)
Battery voltage	≥ 10.9 V
Engine speed	< 3000 rpm
After engine starting	10 seconds or more

**Time Needed for Diagnosis:** To be determined.

**Malfunction Indicator Light Illumination:** Illuminates when malfunction occurs in 2 continuous driving cycles.

### • Normality Judgment

Judge OK and clear the NG when the malfunction criteria below are completed.

### • Judgment Value

Malfunction Criteria	Threshold Value
Accumulated amount of intake air	> 331 kg (729.7 lb)
Max.– Min. fuel level output	≥ 2.6 ℓ (0.69 US gal, 0.57 Imp gal)
Battery voltage	≥ 10.9 V
Engine speed	< 3000 rpm
After engine starting	10 seconds or more

## 6. DTC CLEAR CONDITION

- When the OK idling cycle was completed 40 times in a row
- When “Clear Memory” was performed

## 7. MALFUNCTION INDICATOR LIGHT CLEAR CONDITION

- When the OK driving cycle was completed 3 times in a row
- When “Clear Memory” was performed

## 8. FAIL SAFE

None

## 9. ECM OPERATION AT DTC SETTING

Memorize the freeze frame data. (For test mode \$02)

# DIAGNOSTIC TROUBLE CODE (DTC) DETECTING CRITERIA

## GENERAL DESCRIPTION

### BO:DTC P0462 — FUEL LEVEL SENSOR CIRCUIT LOW INPUT —

#### 1. OUTLINE OF DIAGNOSIS

Detect the open or short circuit of fuel level sensor. Judge NG when out of the standard value.

#### 2. COMPONENT DESCRIPTION

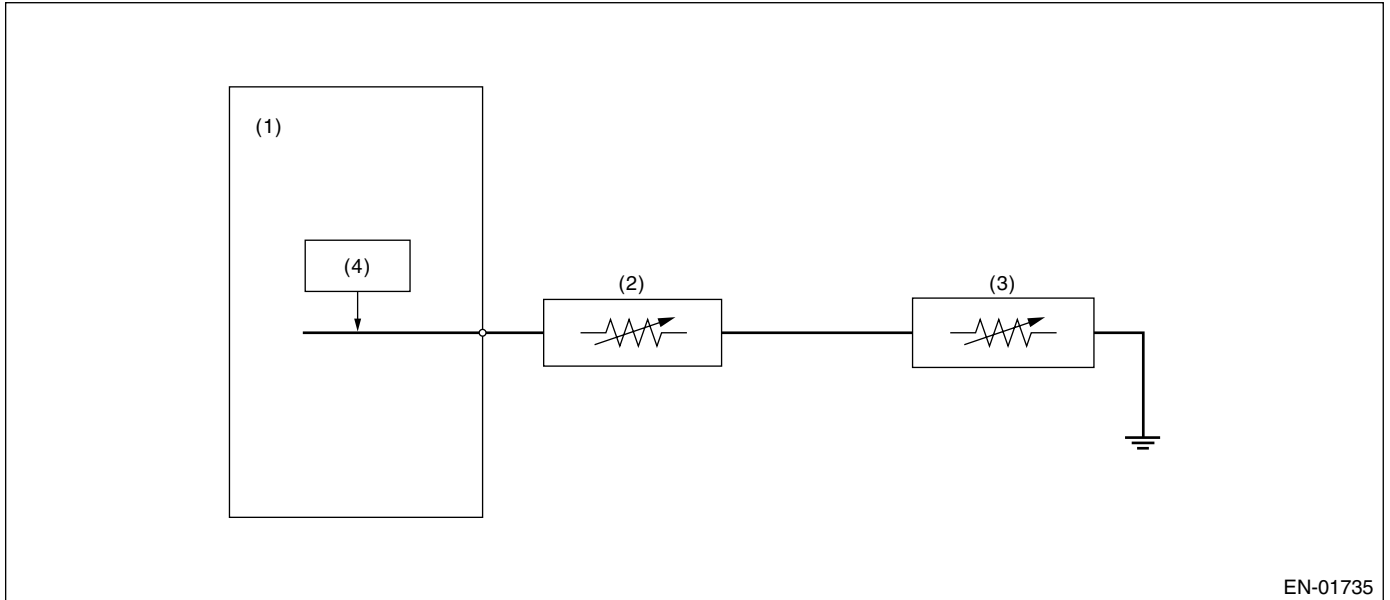

- (1) Engine control module (ECM)      (3) Fuel sub level sensor  
(2) Fuel level sensor                      (4) Detecting circuit

#### 3. ENABLE CONDITION

Secondary Parameters	Enable Conditions
None	

#### 4. GENERAL DRIVING CYCLE

Always perform the diagnosis continuously

# DIAGNOSTIC TROUBLE CODE (DTC) DETECTING CRITERIA

GENERAL DESCRIPTION

## 5. DIAGNOSTIC METHOD

### • Abnormality Judgment

Judge NG when the continuous time of completing the malfunction criteria below becomes more than the time needed for diagnosis (2.5 seconds).

### • Judgment Value

Malfunction Criteria	Threshold Value
Ignition switch	ON
Battery voltage	$\geq 10.9$ V
After engine starting	3 seconds or more
Output voltage	$< 0.02$ V

**Time Needed for Diagnosis:** 2.5 seconds

**Malfunction Indicator Light Illumination:** Illuminates when malfunction occurs in 2 continuous driving cycles.

### • Normality Judgment

Judge OK and clear the NG when the malfunction criteria below are completed.

### • Judgment Value

Malfunction Criteria	Threshold Value
Ignition switch	ON
Battery voltage	$\geq 10.9$ V
After engine starting	3 seconds or more
Output voltage	$\geq 0.02$ V

## 6. DTC CLEAR CONDITION

- When the OK idling cycle was completed 40 times in a row
- When "Clear Memory" was performed

## 7. MALFUNCTION INDICATOR LIGHT CLEAR CONDITION

- When the OK driving cycle was completed 3 times in a row
- When "Clear Memory" was performed

## 8. FAIL SAFE

None

## 9. ECM OPERATION AT DTC SETTING

Memorize the freeze frame data. (For test mode \$02)

# DIAGNOSTIC TROUBLE CODE (DTC) DETECTING CRITERIA

## GENERAL DESCRIPTION

### BP:DTC P0463 — FUEL LEVEL SENSOR CIRCUIT HIGH INPUT —

#### 1. OUTLINE OF DIAGNOSIS

Detect the open or short circuit of fuel level sensor. Judge NG when out of the standard value.

#### 2. COMPONENT DESCRIPTION

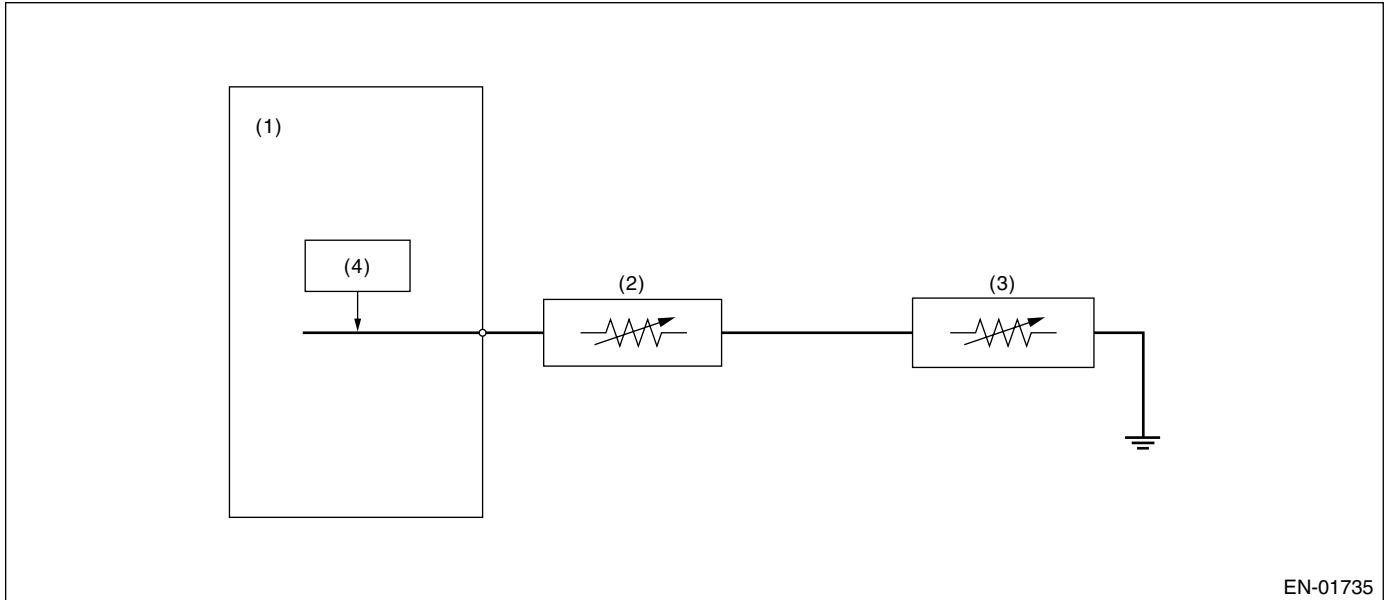

- (1) Engine control module (ECM)
- (2) Fuel level sensor
- (3) Fuel sub level sensor
- (4) Detecting circuit

#### 3. ENABLE CONDITION

Secondary Parameters	Enable Conditions
None	

#### 4. GENERAL DRIVING CYCLE

Always perform the diagnosis continuously



# DIAGNOSTIC TROUBLE CODE (DTC) DETECTING CRITERIA

GENERAL DESCRIPTION

## 5. DIAGNOSTIC METHOD

### • Abnormality Judgment

Judge NG when the continuous time of completing the malfunction criteria below becomes more than the time needed for diagnosis (2.5 second).

### • Judgment Value

Malfunction Criteria	Threshold Value
Ignition switch	ON
Battery voltage	$\geq 10.9$ V
After engine starting	3 seconds or more
Output voltage	$\geq 4.95$ V

**Time Needed for Diagnosis:** 2.5 second

**Malfunction Indicator Light Illumination:** Illuminates when malfunction occurs in 2 continuous driving cycles.

### • Normality Judgment

Judge OK and clear the NG when the malfunction criteria below are completed.

### • Judgment Value

Malfunction Criteria	Threshold Value
Ignition switch	ON
Battery voltage	$\geq 10.9$ V
After engine starting	3 seconds or more
Output voltage	$< 4.95$ V

## 6. DTC CLEAR CONDITION

- When the OK idling cycle was completed 40 times in a row
- When "Clear Memory" was performed

## 7. MALFUNCTION INDICATOR LIGHT CLEAR CONDITION

- When the OK driving cycle was completed 3 times in a row
- When "Clear Memory" was performed

## 8. FAIL SAFE

None

## 9. ECM OPERATION AT DTC SETTING

Memorize the freeze frame data. (For test mode \$02)

# DIAGNOSTIC TROUBLE CODE (DTC) DETECTING CRITERIA

## GENERAL DESCRIPTION

---

### **BQ:DTC P0464 — FUEL LEVEL SENSOR CIRCUIT INTERMITTENT —**

#### **1. OUTLINE OF DIAGNOSIS**

Detect the malfunction of unstable output from fuel level sensor caused by noise.

Judge NG when the max. value and cumulative value of output voltage variation of fuel level sensor is larger than the threshold value.

#### **2. ENABLE CONDITION**

Secondary Parameters	Enable Conditions
Engine speed	≥ 500 rpm
After engine starting	1 second or more
Ignition switch	ON
Battery voltage	> 10.9 V
Idle switch	ON
Fuel level	9.6 ↔ 48 ℓ (2.54 ↔ 12.68 US gal, 2.11 ↔ 10.56 Imp gal)
Vehicle speed = 0 km/h (0 MPH)	10 seconds or more

#### **3. GENERAL DRIVING CYCLE**

- Perform the diagnosis continuously in idling condition.
- Pay attention to the fuel level.

# DIAGNOSTIC TROUBLE CODE (DTC) DETECTING CRITERIA

GENERAL DESCRIPTION

## 4. DIAGNOSTIC METHOD

Calculate the Max. value (delvflmx) and cumulative value (sumvfl) of output voltage variation of fuel level sensor during 10.2 seconds. Judge it normal when both max. and cumulative values are not over the threshold value. Otherwise, when either of them is over the threshold value, count the diagnosis counter up. And judge NG if the counter indicated 4 counts.

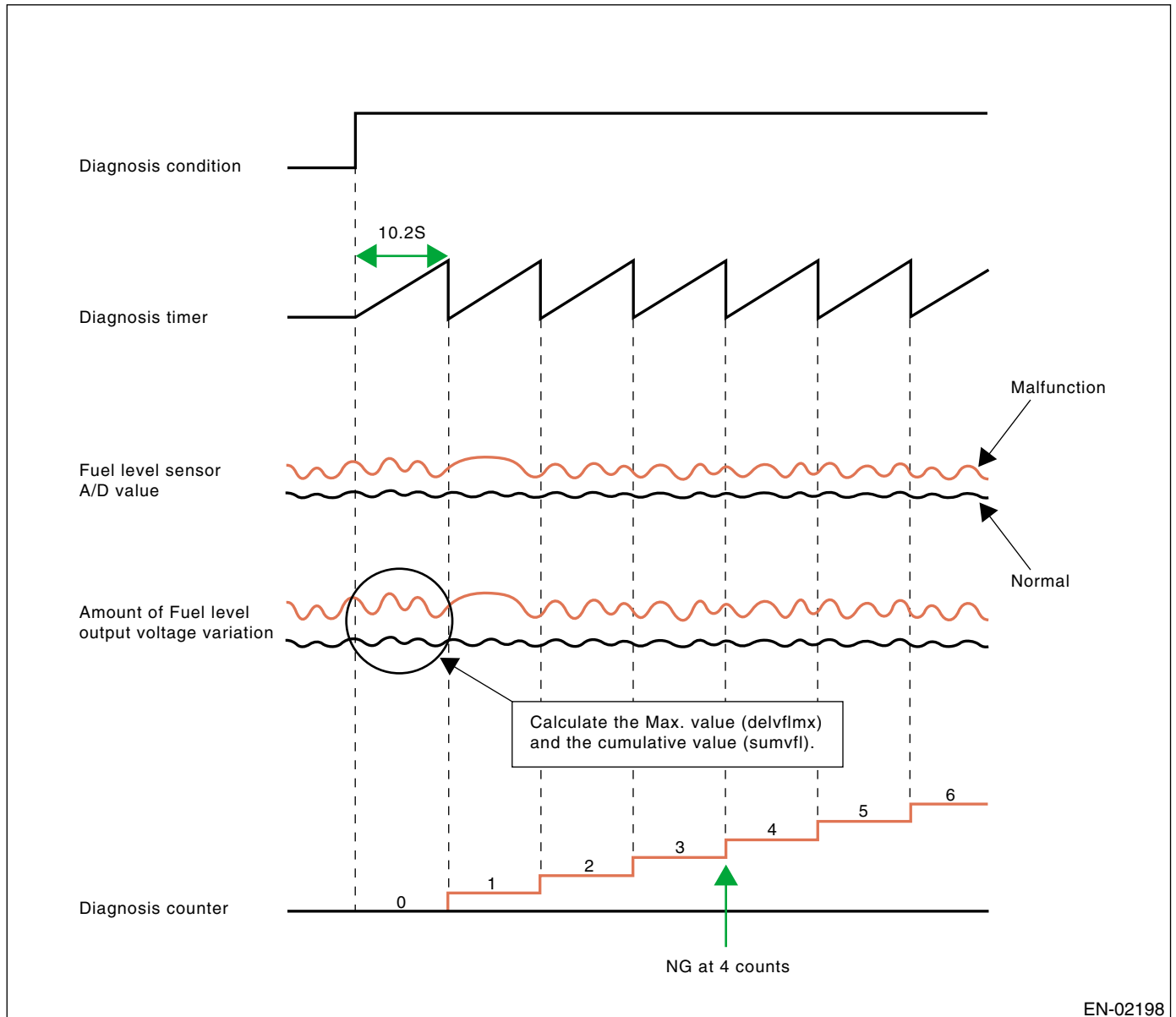

# DIAGNOSTIC TROUBLE CODE (DTC) DETECTING CRITERIA

## GENERAL DESCRIPTION

---

### • Abnormality Judgment

Judge NG when the malfunction criteria below are completed.

### • Judgment Value

Malfunction Criteria	Threshold Value
Integrated times of the condition reaching follows, DELFLMAX $\geq 0.2$ V or SUMFL $\geq 16$ V where, DELFLMAX is Max. deviation of sensor output during 10.2 seconds. SUMFL is integrated value of sensor output deviation during 10.2 seconds.	$\geq 4$ times

Do not count the diagnosis counter up when the following conditions are completed during 10.2 seconds.

Max – Min of tank pressure during 10.2 seconds	$\geq 0.05$ kPa (0.375 mmHg, 0.02 inHg)
Max – Min of battery voltage during 10.2 seconds	$\geq 0.275$ V

**Time Needed for Diagnosis:** 10.2 seconds  $\times$  4 times

**Malfunction Indicator Light Illumination:** Illuminates when malfunction occurs in 2 continuous driving cycles.

### • Normality Judgment

Judge OK and clear the NG when the malfunction criteria below are completed.

### • Judgment Value

Malfunction Criteria	Threshold Value
DELFLMAX	$< 0.2$ V
SUMFL	$< 16$ V
Where, DELFLMAX is Max. deviation of sensor output during 10.2 seconds. SUMFL is integrated value of sensor output deviation during 10.2 seconds.	

## 5. DTC CLEAR CONDITION

- When the OK idling cycle was completed 40 times in a row
- When "Clear Memory" was performed

## 6. MALFUNCTION INDICATOR LIGHT CLEAR CONDITION

- When the OK driving cycle was completed 3 times in a row
- When "Clear Memory" was performed

## 7. FAIL SAFE

None

## 8. ECM OPERATION AT DTC SETTING

Memorize the freeze frame data. (For test mode \$02)

# DIAGNOSTIC TROUBLE CODE (DTC) DETECTING CRITERIA

GENERAL DESCRIPTION

---

MEMO:

# DIAGNOSTIC TROUBLE CODE (DTC) DETECTING CRITERIA

## GENERAL DESCRIPTION

### BR:DTC P0483 — COOLING FAN RATIONALITY CHECK —

#### 1. OUTLINE OF DIAGNOSIS

Detect the function abnormality of the radiator fan.

Judge NG when the engine coolant temperature slowly decreases even when the radiator fan is rotating.

#### 2. ENABLE CONDITION

Diagnostic enable condition is completed if the radiator fan changes from OFF to ON when all of the conditions below are completed. When one of the conditions below is not completed, the diagnostic enable condition is not completed.

Secondary Parameters	Enable Conditions
Engine Speed	500 — 900 rpm
Idle switch	ON
Vehicle speed	= 0 km/h (0 MPH)
Battery voltage	≥ 10.9 V

#### 3. GENERAL DRIVING CYCLE

Perform the diagnosis continuously when the radiator fan changes from OFF to ON when idling.

#### 4. DIAGNOSTIC METHOD

##### • Abnormality Judgment

Judge NG when the continuous time of completing the malfunction criteria below becomes more than 5 minutes.

##### • Judgment Value

Malfunction Criteria	Threshold Value
Engine coolant temperature	≥ 98°C (208°F)
Change of radiator fan signal	OFF to ON
Engine coolant temperature	Does not decrease

**Time Needed for Diagnosis:** 5 minutes

**Malfunction Indicator Light Illumination:** Illuminates when malfunction occurs in 2 continuous driving cycles.

##### • Normality Judgment

Judge OK and clear NG when the malfunction criteria below are completed.

##### • Judgment Value

Malfunction Criteria	Threshold Value
Change of radiator fan signal	OFF to ON
Engine coolant temperature	Decrease

#### 5. DTC CLEAR CONDITION

- When the OK idling cycle was completed 40 times in a row
- When “Clear Memory” was performed

#### 6. MALFUNCTION INDICATOR LIGHT CLEAR CONDITION

- When the OK driving cycle was completed 3 times in a row
- When “Clear Memory” was performed

#### 7. FAIL SAFE

None

#### 8. ECM OPERATION AT DTC SETTING

Memorize the freeze frame data. (For test mode \$02)

# DIAGNOSTIC TROUBLE CODE (DTC) DETECTING CRITERIA

GENERAL DESCRIPTION

## BS:DTC P0502 — VEHICLE SPEED SENSOR CIRCUIT LOW INPUT —

### 1. OUTLINE OF DIAGNOSIS

Detect the open or short circuit of vehicle speed sensor.

Judge NG when low vehicle speed (0 km/h (0 MPH)) remains whereas it seemed to be in a usual driving speed.

### 2. ENABLE CONDITION

Secondary Parameters	Enable Conditions
Engine speed	< 4000 rpm
Fuel cut in decel.	Operating
Battery voltage	≥ 10.9 V

### 3. GENERAL DRIVING CYCLE

Perform the diagnosis continuously during fuel cut in deceleration.

### 4. DIAGNOSTIC METHOD

#### • Abnormality Judgment

Judge NG when the continuous time of completing the malfunction criteria below becomes more than 4 seconds.

#### • Judgment Value

Malfunction Criteria	Threshold Value
Vehicle speed	< 1

**Time Needed for Diagnosis:** 4 seconds

**Malfunction Indicator Light Illumination:** Illuminates as soon as the malfunction occurs.

#### • Normality Judgment

Judge OK and clear NG when the malfunction criteria below are completed.

#### • Judgment Value

Malfunction Criteria	Threshold Value
Vehicle speed	≥ 1
Starter switch	OFF
Time after starter SW turns from ON to OFF.	≥ 3 seconds

### 5. DTC CLEAR CONDITION

- When the OK idling cycle was completed 40 times in a row
- When "Clear Memory" was performed

### 6. MALFUNCTION INDICATOR LIGHT CLEAR CONDITION

- When the OK driving cycle was completed 3 times in a row
- When "Clear Memory" was performed

### 7. FAIL SAFE

- Throttle position sensor signal process: Fix the all closed position learning value at 0°.
- Vehicle speed sensor signal process: Vehicle speed = 10 km/h (6 MPH)
- Fuel cut control: Vehicle speed = 0 km/h (0 MPH) / Not allowed to carry out the fuel cut.
- ISC open loop compensation: Fix the open loop compensation at 6.82%
- ISC feedback control: Not allowed to calculate the amount of ISC feedback.
- Air conditioner control: Air conditioner cut signal is not allowed driving acceleration.
- Radiator fan control: Both main and sub fan are in High driving.

### 8. ECM OPERATION AT DTC SETTING

Memorize the freeze frame data. (For test mode \$02)

# DIAGNOSTIC TROUBLE CODE (DTC) DETECTING CRITERIA

## GENERAL DESCRIPTION

### BT:DTC P0503 — VEHICLE SPEED SENSOR INTERMITTENT/ERRATIC/HIGH —

#### 1. OUTLINE OF DIAGNOSIS

Detect the open or short circuit of vehicle speed sensor.

Judge NG when high vehicle speed (240 km/h (149.1 MPH) or more) remains whereas it seemed to be in a usual driving speed.

#### 2. ENABLE CONDITION

Secondary Parameters	Enable Conditions
Engine speed	< 4000 rpm
Fuel cut in decel.	Operating
Battery voltage	≥ 10.9 V

#### 3. GENERAL DRIVING CYCLE

Perform the diagnosis continuously during fuel cut in deceleration.

#### 4. DIAGNOSTIC METHOD

##### • Abnormality Judgment

Judge NG when the cumulative time of completing the malfunction criteria below becomes more than 4 seconds.

##### • Judgment Value

Malfunction Criteria	Threshold Value
Vehicle speed	≥ 240

**Time Needed for Diagnosis:** 4 seconds

**Malfunction Indicator Light Illumination:** Illuminates as soon as the malfunction occurs.

##### • Normality Judgment

Judge OK and clear NG when the malfunction criteria below are completed.

##### • Judgment Value

Malfunction Criteria	Threshold Value
Vehicle speed	< 240
Starter switch	OFF
Time after starter switch turns from ON to OFF.	≥ 3 seconds

#### 5. DTC CLEAR CONDITION

- When the OK idling cycle was completed 40 times in a row
- When "Clear Memory" was performed

#### 6. MALFUNCTION INDICATOR LIGHT CLEAR CONDITION

- When the OK driving cycle was completed 3 times in a row
- When "Clear Memory" was performed

#### 7. FAIL SAFE

- Throttle position sensor signal process: Fix the all closed position learning value at 0°.
- Vehicle speed sensor signal process: Vehicle speed = 10 km/h (6 MPH)
- Fuel cut control: Vehicle speed = 0 km/h (0 MPH) / Not allowed to carry out the fuel cut.
- ISC open loop compensation: Fix the open loop compensation at 5%
- ISC feedback control: Not allowed to calculate the amount of ISC feedback.
- Air conditioner control: Air conditioner cut signal is not allowed driving acceleration.
- Radiator fan control: Both main and sub fan are in High driving.

#### 8. ECM OPERATION AT DTC SETTING

Memorize the freeze frame data. (For test mode \$02)



# DIAGNOSTIC TROUBLE CODE (DTC) DETECTING CRITERIA

GENERAL DESCRIPTION

---

MEMO:

# DIAGNOSTIC TROUBLE CODE (DTC) DETECTING CRITERIA

## GENERAL DESCRIPTION

### BU:DTC P0506 — IDLE CONTROL SYSTEM RPM LOWER THAN EXPECTED —

#### 1. OUTLINE OF DIAGNOSIS

Detect the malfunction that actual engine speed is not close to target engine speed during idling.  
Judge NG when actual engine speed is not close to target engine speed during idling.

#### 2. COMPONENT DESCRIPTION

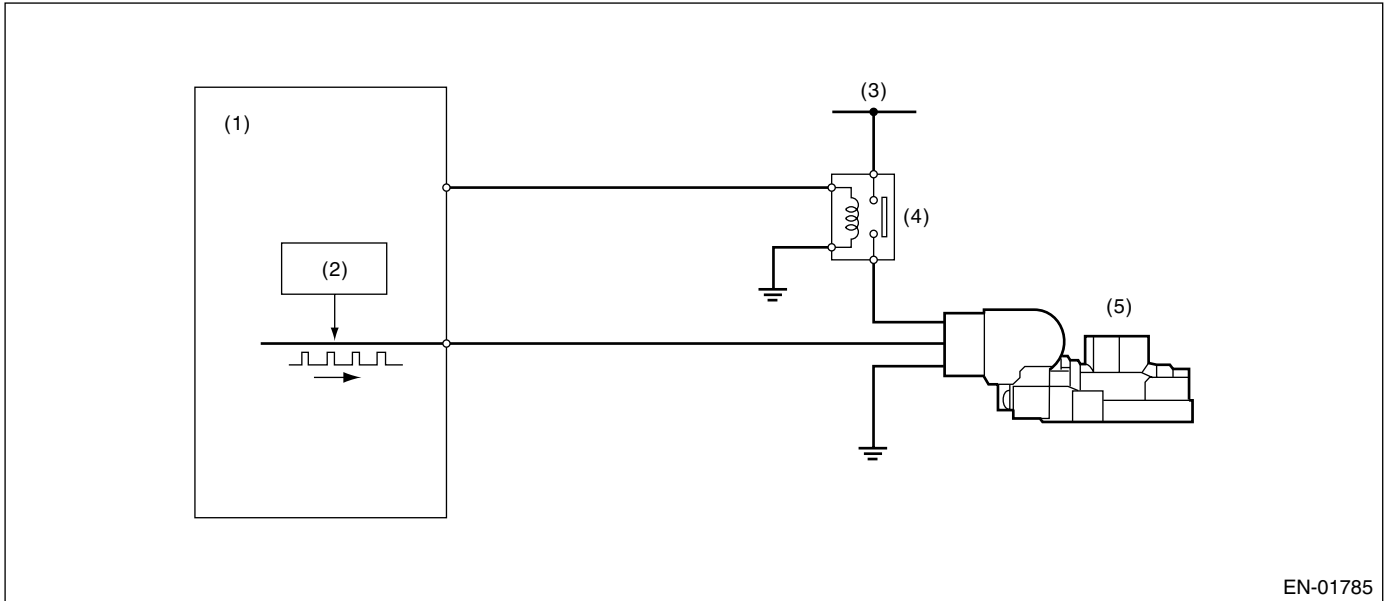

EN-01785

(1) Engine control module (ECM)  
(2) Detecting circuit

(3) Battery voltage  
(4) Main relay

(5) Idle air control solenoid valve

#### 3. ENABLE CONDITION

Secondary Parameters	Enable Conditions
Engine coolant temperature	≥ 75°C (167°F)
Battery voltage	≥ 10.9 V
Atmospheric pressure	> 75.1 kPa (563 mmHg, 22.2 inHg)
Fuel level	≥ 9.6 ℓ (2.54 US gal, 2.11 Imp gal)
After engine starting	10 seconds or more
Feedback in ISC	In operation
Measured lambda (both left and right)	0.81 ↔ 1.1
After air condition switching ON-OFF, OFF-ON	5 seconds or more
After in-manifold pressure change more than 4 kPa (30 mmHg, 1.2 inHg)	> 5 seconds
After neutral switch ON-OFF event	> 5 seconds
Vehicle speed	0 km/h (0 MPH)

#### 4. GENERAL DRIVING CYCLE

Always perform diagnosis during idling after warm-up:

# DIAGNOSTIC TROUBLE CODE (DTC) DETECTING CRITERIA

GENERAL DESCRIPTION

## 5. DIAGNOSTIC METHOD

### • Abnormality Judgment

Judge NG when the cumulative time of completing the malfunction criterion below becomes more than the time needed for diagnosis (10 seconds × 3 times).

### • Judgment Value

Malfunction Criteria	Threshold Value
Actual – target engine speed	< –100 rpm
Feedback correction for idle air control solenoid valve	Max.

**Time Needed for Diagnosis:** 10 seconds × 3 times

**Malfunction Indicator Light Illumination:** Illuminates when malfunction occurs in 2 continuous driving cycles.

### • Normality Judgment

Judge OK and clear NG when the continuous time of completing the malfunction criterion below becomes more than the time needed for diagnosis (10 seconds).

### • Judgment Value

Malfunction Criteria	Threshold Value
Actual – target engine speed	≥ –100 rpm

## 6. DTC CLEAR CONDITION

- When the OK idling cycle was completed 40 times in a row
- When “Clear Memory” was performed

## 7. MALFUNCTION INDICATOR LIGHT CLEAR CONDITION

- When the OK driving cycle was completed 3 times in a row
- When “Clear Memory” was performed

## 8. FAIL SAFE

Judgment of heavy fuel: Not allowed to make the judgment of heavy fuel.

## 9. ECM OPERATION AT DTC SETTING

Memorize the freeze frame data. (For test mode \$02)

# DIAGNOSTIC TROUBLE CODE (DTC) DETECTING CRITERIA

## GENERAL DESCRIPTION

### BV:DTC P0507 — IDLE CONTROL SYSTEM RPM HIGHER THAN EXPECTED —

#### 1. OUTLINE OF DIAGNOSIS

Detect the malfunction that actual engine speed is not close to target engine speed during idling.  
Judge NG when actual engine speed is not close to target engine speed during idling.

#### 2. COMPONENT DESCRIPTION

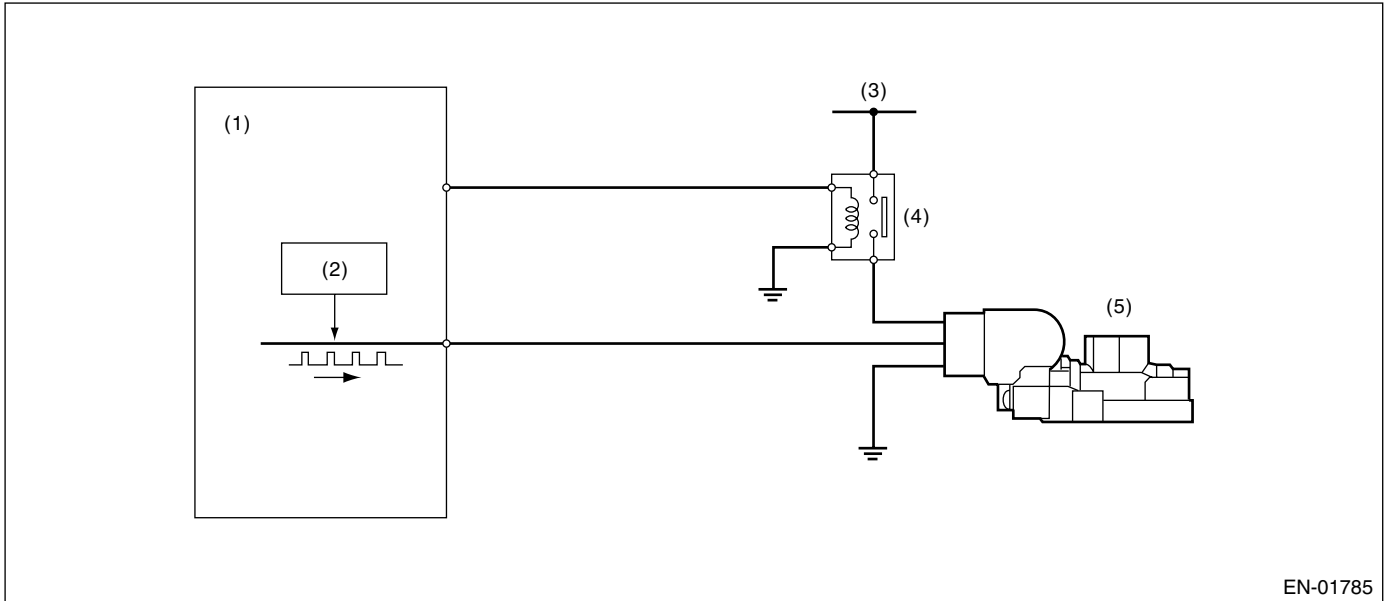

(1) Engine control module (ECM)  
(2) Detecting circuit

(3) Battery voltage  
(4) Main relay

(5) Idle air control solenoid valve

#### 3. ENABLE CONDITION

Secondary Parameters	Enable Conditions
Engine coolant temperature	$\geq 75^{\circ}\text{C}$ ( $167^{\circ}\text{F}$ )
Battery voltage	$\geq 10.9\text{ V}$
Atmospheric pressure	$> 75.1\text{ kPa}$ ( $563\text{ mmHg}$ , $22.2\text{ inHg}$ )
Fuel level	$\geq 9.6\text{ l}$ ( $2.54\text{ US gal}$ , $2.11\text{ Imp gal}$ )
After engine starting	10 seconds or more
Feedback in ISC	In operation
Lambda (both left and right)	$0.81 \leftrightarrow 1.1$
After air condition switching ON-OFF, OFF-ON	5 seconds or more
After in-manifold pressure change more than $4\text{ kPa}$ ( $30\text{ mmHg}$ , $1.2\text{ inHg}$ )	$> 5\text{ seconds}$
After neutral switch ON-OFF event	$> 5\text{ seconds}$
Vehicle speed	$0\text{ km/h}$ ( $0\text{ MPH}$ )

#### 4. GENERAL DRIVING CYCLE

Always perform diagnosis during idling after warm-up.

# DIAGNOSTIC TROUBLE CODE (DTC) DETECTING CRITERIA

GENERAL DESCRIPTION

## 5. DIAGNOSTIC METHOD

### • Abnormality Judgment

Judge NG when the continuous time of completing the malfunction criterion below becomes more than the time needed for diagnosis (10 seconds  $\times$  3 times).

### • Judgment Value

Malfunction Criteria	Threshold Value
Actual – target eng. speed	$\geq 200$ rpm
Feedback correction for idle air control solenoid valve	Min.

**Time Needed for Diagnosis:** 10 seconds  $\times$  3 times

**Malfunction Indicator Light Illumination:** Illuminates when malfunction occurs in 2 continuous driving cycles.

### • Normality Judgment

Judge OK and clear NG when the continuous time of completing the malfunction criterion below becomes more than the time needed for diagnosis (10 seconds).

### • Judgment Value

Malfunction Criteria	Threshold Value
Actual – target eng. speed	$< 200$ rpm

## 6. DTC CLEAR CONDITION

- When the OK idling cycle was completed 40 times in a row
- When “Clear Memory” was performed

## 7. MALFUNCTION INDICATOR LIGHT CLEAR CONDITION

- When the OK driving cycle was completed 3 times in a row
- When “Clear Memory” was performed

## 8. FAIL SAFE

Judgment of heavy fuel: Not allowed to make the judgment of heavy fuel.

## 9. ECM OPERATION AT DTC SETTING

Memorize the freeze frame data. (For test mode \$02)

# DIAGNOSTIC TROUBLE CODE (DTC) DETECTING CRITERIA

## GENERAL DESCRIPTION

### BW:DTC P0508 — IDLE CONTROL SYSTEM CIRCUIT LOW —

#### 1. OUTLINE OF DIAGNOSIS

Detect open or short circuit in idle air control solenoid valve.  
 Period of idle air control solenoid valve is 4 milliseconds and it is too short.  
 Judge OK/NG in accordance with the number of change of OFF to ON signal.

#### 2. COMPONENT DESCRIPTION

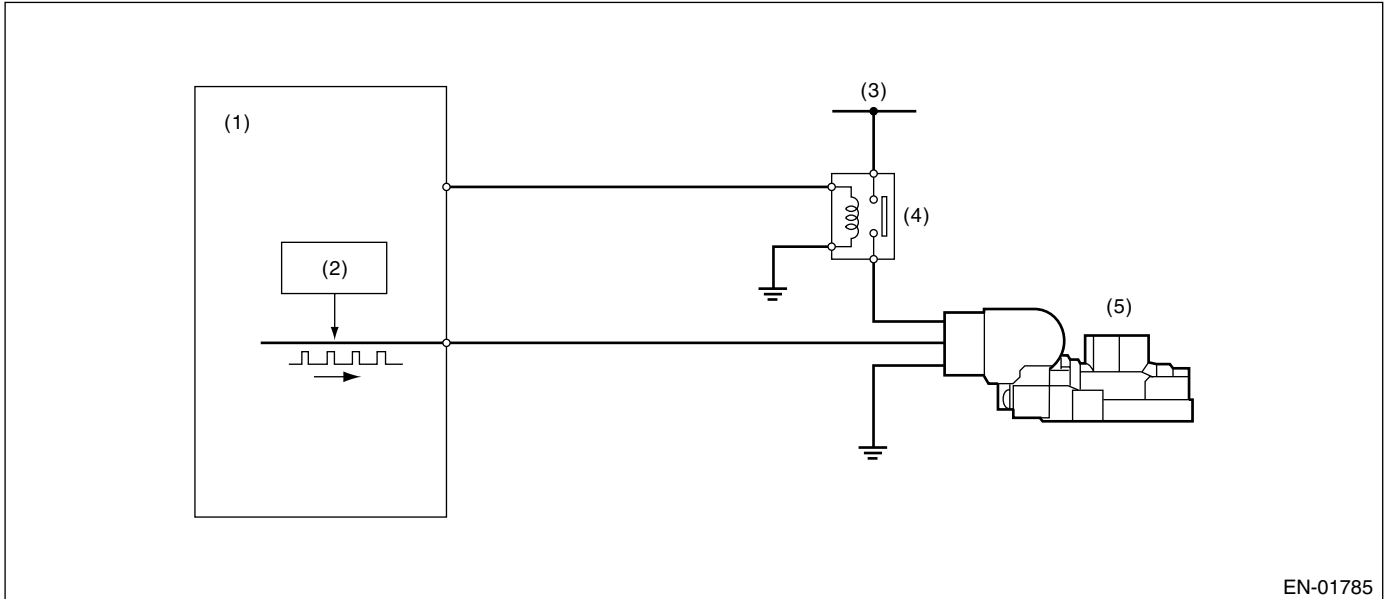

(1) Engine control module (ECM)  
 (2) Detecting circuit

(3) Battery voltage  
 (4) Main relay

(5) Idle air control solenoid valve

#### 3. ENABLE CONDITION

Secondary Parameters	Enable Conditions
After engine starting	1 second or more
Idle air control solenoid valve duty ratio	5 — 95%
Battery voltage	≥ 10.9 V

#### 4. GENERAL DRIVING CYCLE

Perform the diagnosis after starting the engine.

#### 5. DIAGNOSTIC METHOD

Judge NG when the malfunction criteria below are completed. Judge OK and clear NG when the malfunction criteria below are not completed.

##### Judgment Value

Malfunction Criteria	Threshold Value
Number of change that idle air control solenoid valve signal during 64 milliseconds. (16 at normal since the cycle is 4 milliseconds)	≤ 8

**Time Needed for Diagnosis:** 64 milliseconds

**Malfunction Indicator Light Illumination:** Illuminates as soon as malfunction occurs.

#### 6. DTC CLEAR CONDITION

- When the OK idling cycle was completed 40 times in a row
- When "Clear Memory" was performed

# DIAGNOSTIC TROUBLE CODE (DTC) DETECTING CRITERIA

GENERAL DESCRIPTION

---

## 7. MALFUNCTION INDICATOR LIGHT CLEAR CONDITION

- When the OK driving cycle was completed 3 times in a row
- When "Clear Memory" was performed

## 8. FAIL SAFE

- Idle air control solenoid valve feedback correction: Not allowed to calculate ifb (idle air control solenoid valve feedback amount)
- Fuel shut-off: Shut-off fuel for only #1 and #2 cylinder, or for all cylinder in accordance with vehicle speed, engine speed, throttle position
- Judgment of heavy fuel: Not allowed to make the judgment of heavy fuel

## 9. ECM OPERATION AT DTC SETTING

Memorize the freeze frame data. (For test mode \$02)

# DIAGNOSTIC TROUBLE CODE (DTC) DETECTING CRITERIA

## GENERAL DESCRIPTION

### BX:DTC P0509 — IDLE CONTROL SYSTEM CIRCUIT HIGH —

#### 1. OUTLINE OF DIAGNOSIS

Detect open or short circuit in idle air control solenoid valve.  
 Period of idle air control solenoid valve is 4 milliseconds and it is too short.  
 Judge OK/NG in accordance with the number of change of OFF to ON signal.

#### 2. COMPONENT DESCRIPTION

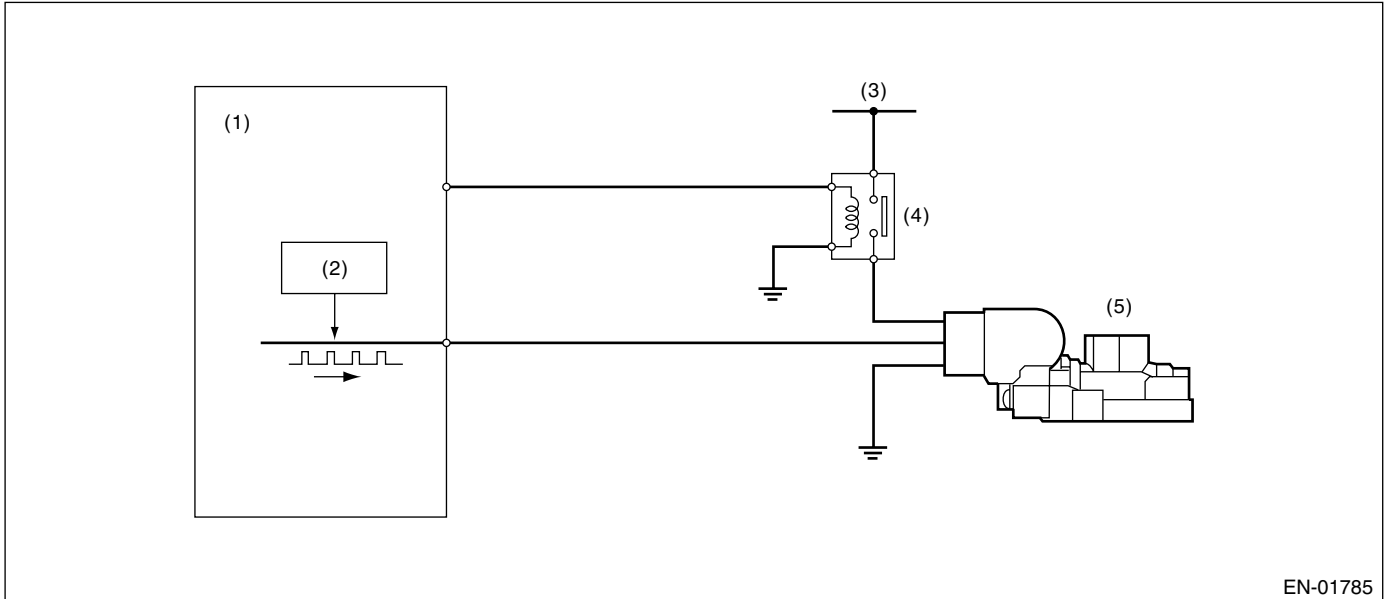

(1) Engine control module (ECM)  
 (2) Detecting circuit

(3) Battery voltage  
 (4) Main relay

(5) Idle air control solenoid valve

#### 3. ENABLE CONDITION

Secondary Parameters	Enable Conditions
After engine starting	1 second or more
Idle air control solenoid valve duty ratio	5 — 95%
Battery voltage	≥ 10.9 V

#### 4. GENERAL DRIVING CYCLE

Perform the diagnosis after starting the engine.

#### 5. DIAGNOSTIC METHOD

Judge NG when the malfunction criteria below are completed. Judge OK and clear NG when the malfunction criteria below are not completed.

##### Judgment Value

Malfunction Criteria	Threshold Value
Number of change that idle air control solenoid valve signal during 64 milliseconds. (16 at normal since the cycle is 4 milliseconds)	≥ 225

**Time Needed for Diagnosis:** 64 milliseconds

**Malfunction Indicator Light Illumination:** Illuminates as soon as malfunction occurs.

#### 6. DTC CLEAR CONDITION

- When the OK idling cycle was completed 40 times in a row
- When “Clear Memory” was performed



# DIAGNOSTIC TROUBLE CODE (DTC) DETECTING CRITERIA

GENERAL DESCRIPTION

---

## 7. MALFUNCTION INDICATOR LIGHT CLEAR CONDITION

- When the OK driving cycle was completed 3 times in a row
- When "Clear Memory" was performed

## 8. FAIL SAFE

- Idle air control solenoid valve feedback correction: Not allowed to calculate ifb (idle air control solenoid valve feedback amount)
- Fuel shut-off: Shut-off fuel for only #1 and #2 cylinder, or for all cylinder in accordance with vehicle speed, engine speed, throttle position
- Judgment of heavy fuel: Not allowed to make the judgment of heavy fuel

## 9. ECM OPERATION AT DTC SETTING

Memorize the freeze frame data. (For test mode \$02)

# DIAGNOSTIC TROUBLE CODE (DTC) DETECTING CRITERIA

## GENERAL DESCRIPTION

---

### BY:DTC P0512 — STARTER REQUEST CIRCUIT —

#### 1. OUTLINE OF DIAGNOSIS

Detect the open or short circuit of starter SW.

Judge ON NG when the starter SW signal remains to be on.

#### 2. ENABLE CONDITION

Secondary Parameters	Enable Conditions
None	

#### 3. GENERAL DRIVING CYCLE

Always perform the diagnosis continuously.

#### 4. DIAGNOSTIC METHOD

##### • Abnormality Judgment

Judge NG when the continuous time of completing the malfunction criteria below becomes more than 3 minutes.

##### • Judgment Value

Malfunction Criteria	Threshold Value
Engine speed	> 500 rpm
Starter OFF signal	Undetected
Battery voltage	> 8 V

**Time Needed for Diagnosis:** 180 seconds

**Malfunction Indicator Light Illumination:** Illuminates when malfunction occurs in 2 continuous driving cycles.

##### • Normality Judgment

Judge ON OK and clear the NG when the malfunction criteria below are completed.

##### • Judgment Value

Malfunction Criteria	Threshold Value
Starter SW	OFF
Battery voltage	> 8 V

#### 5. DTC CLEAR CONDITION

- When the OK idling cycle was completed 40 times in a row
- When "Clear Memory" was performed

#### 6. MALFUNCTION INDICATOR LIGHT CLEAR CONDITION

- When the OK driving cycle was completed 3 times in a row
- When "Clear Memory" was performed

#### 7. FAIL SAFE

None

#### 8. ECM OPERATION AT DTC SETTING

Memorize the freeze frame data. (For test mode \$02)

# DIAGNOSTIC TROUBLE CODE (DTC) DETECTING CRITERIA

GENERAL DESCRIPTION

---

MEMO:

# DIAGNOSTIC TROUBLE CODE (DTC) DETECTING CRITERIA

## GENERAL DESCRIPTION

### BZ:DTC P0519 — IDLE CONTROL SYSTEM MALFUNCTION (FAIL-SAFE) —

#### 1. OUTLINE OF DIAGNOSIS

Detect the malfunction that engine speed increases more than that in normal condition during idling.

#### 2. COMPONENT DESCRIPTION

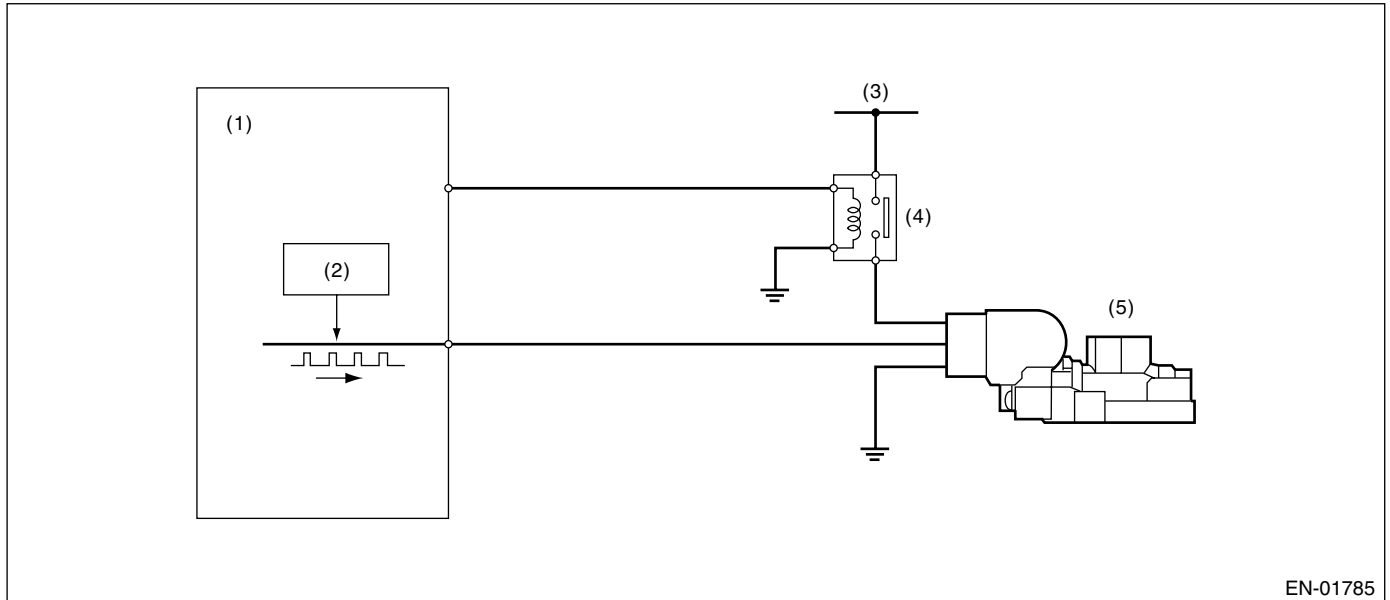

EN-01785

(1) Engine control module (ECM)

(3) Battery voltage

(5) Idle air control solenoid valve

(2) Detecting circuit

(4) Main relay

#### 3. ENABLE CONDITION

Secondary Parameters	Enable Conditions
Battery voltage	$\geq 10.9 \text{ V}$
Feedback in ISC	In operation
Vehicle speed	$< 4 \text{ km/h (2.49 MPH)}$
After engine starting	1 seconds or more

#### 4. GENERAL DRIVING CYCLE

Always perform diagnosis at less than 4 km/h (2.49 MPH) of vehicle speed.

# DIAGNOSTIC TROUBLE CODE (DTC) DETECTING CRITERIA

GENERAL DESCRIPTION

## 5. DIAGNOSTIC METHOD

Judge NG when the continuous time until completing the all malfunction criteria below becomes more than the time needed for diagnosis (2 seconds).

### Judgment Value

Malfunction Criteria	Threshold Value
Engine speed – target eng. speed	$\geq 650$ rpm
Feedback value for ISC	$\leq 0$
Engine speed change every 120°C engine rev.	$\geq -5$ rpm

**Time Needed for Diagnosis:** 2 seconds

**Malfunction Indicator Light Illumination:** Illuminates as soon as malfunction occurs.

### • Normality Judgment

Judge OK and clear NG when the continuous time until completing the malfunction criteria below becomes more than the time needed for diagnosis (5 seconds).

### • Judgment Value

Malfunction Criteria	Threshold Value
Engine speed – target eng. speed	$< 200$ rpm

## 6. DTC CLEAR CONDITION

- When the OK idling cycle was completed 40 times in a row
- When “Clear Memory” was performed

## 7. MALFUNCTION INDICATOR LIGHT CLEAR CONDITION

- When the OK driving cycle was completed 3 times in a row
- When “Clear Memory” was performed

## 8. FAIL SAFE

Fuel shut-off: Shut-off fuel for only #1 and #2 cylinder, or for all cylinder in accordance with vehicle speed, engine speed, throttle position

## 9. ECM OPERATION AT DTC SETTING

Memorize the freeze frame data. (For test mode \$02)

# DIAGNOSTIC TROUBLE CODE (DTC) DETECTING CRITERIA

## GENERAL DESCRIPTION

---

### CA:DTC P0565 — CRUISE CONTROL ON SIGNAL —

#### 1. OUTLINE OF DIAGNOSIS

Judge NG when the cruise control set signal is continued to be ON for a certain period of time at the vehicle speed less than 20 km/h (12 MPH).

#### 2. ENABLE CONDITION

Secondary Parameters	Enable Conditions
Vehicle speed	≤ 20 km/h (12.4 MPH)

#### 3. GENERAL DRIVING CYCLE

Always perform diagnosis at vehicle speed 20 km/h (12.4 MPH) or less.

#### 4. DIAGNOSTIC METHOD

##### Judgment Value

Malfunction Criteria	Threshold Value
Canceling signal	No signal

**Time Needed for Diagnosis:** 10 seconds

**Malfunction Indicator Light Illumination:** Illuminates when malfunction occurs in 2 continuous driving cycles.

#### 5. DTC CLEAR CONDITION

- When the OK idling cycle was completed 40 times in a row
- When "Clear Memory" was performed

#### 6. MALFUNCTION INDICATOR LIGHT CLEAR CONDITION

- When the OK driving cycle was completed 3 times in a row
- When "Clear Memory" was performed

#### 7. FAIL SAFE

None

#### 8. ECM OPERATION AT DTC SETTING

Memorize the freeze frame data. (For test mode \$02)

# DIAGNOSTIC TROUBLE CODE (DTC) DETECTING CRITERIA

GENERAL DESCRIPTION

## CB:DTC P0604 — INTERNAL CONTROL MODULE RANDOM ACCESS MEMORY (RAM) ERROR —

### 1. OUTLINE OF DIAGNOSIS

Detect the function abnormality of the micro-computer (RAM).

Normally, zero-clear all the RAM area in the initial routine. And judge NG when the total of all the RAM after the clear is not \$0000.

### 2. ENABLE CONDITION

Secondary Parameters	Enable Conditions
None	

Perform the diagnosis in the initial routine.

### 3. GENERAL DRIVING CYCLE

Perform the diagnosis immediately after IG key SW is turned ON.

### 4. DIAGNOSTIC METHOD

Judge NG when the malfunction criteria below are completed. Judge OK and clear NG when the malfunction criteria below are not completed.

#### Judgment Value

Malfunction Criteria	Threshold Value
Total of all the RAM after the zero-clear the all the normal RAM area.	Not to 0

**Time Needed for Diagnosis:** Undecided

**Malfunction Indicator Light Illumination:** Illuminates as soon as malfunction occurs.

### 5. DTC CLEAR CONDITION

- When the OK idling cycle was completed 40 times in a row
- When "Clear Memory" was performed

### 6. MALFUNCTION INDICATOR LIGHT CLEAR CONDITION

- When the OK driving cycle was completed 3 times in a row
- When "Clear Memory" was performed

### 7. FAIL SAFE

None

### 8. ECM OPERATION AT DTC SETTING

Memorize the freeze frame data. (For test mode \$02)

# DIAGNOSTIC TROUBLE CODE (DTC) DETECTING CRITERIA

## GENERAL DESCRIPTION

### CC:DTC P0661 — INTAKE MANIFOLD TUNING VALVE CONTROL CIRCUIT LOW — BANK 1 — —

#### 1. OUTLINE OF DIAGNOSIS

Detect the open or short circuit of intake manifold tuning valve control.  
Judge NG when the ECM output level is different from actual terminal level.

#### 2. COMPONENT DESCRIPTION

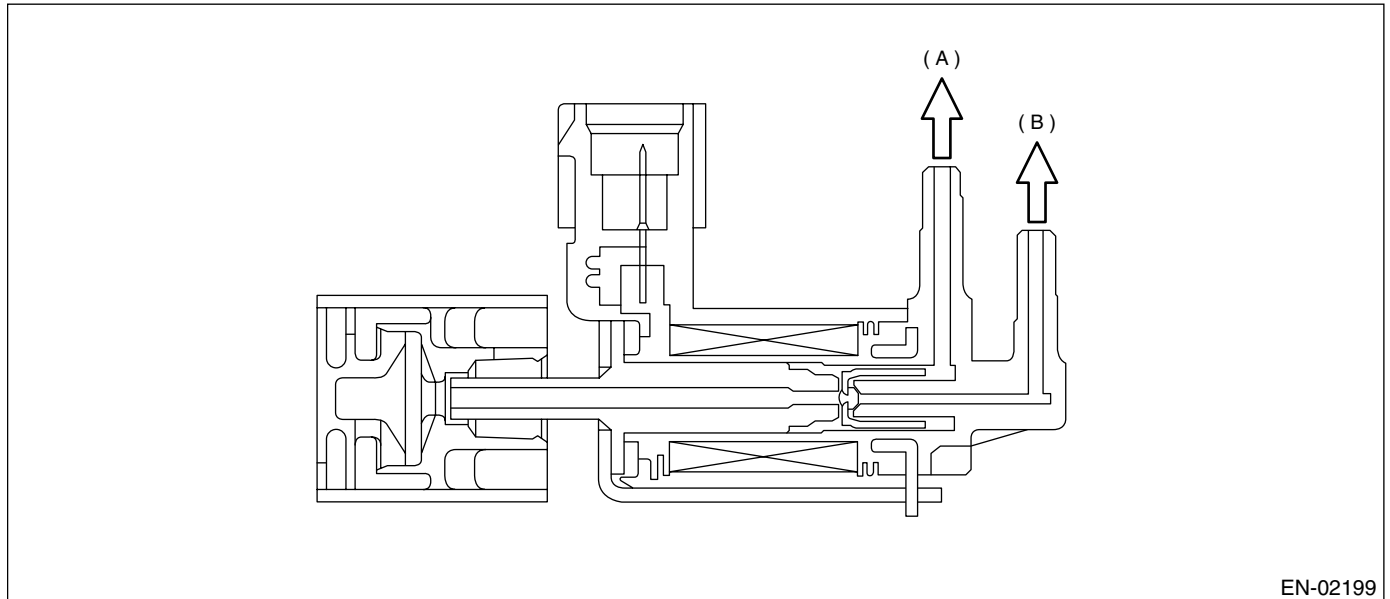

EN-02199

(A) To intake manifold

(B) To variable intake valve

#### 3. ENABLE CONDITION

Secondary Parameters	Enable Conditions
None	

#### 4. GENERAL DRIVING CYCLE

Always perform the diagnosis continuously.



# DIAGNOSTIC TROUBLE CODE (DTC) DETECTING CRITERIA

GENERAL DESCRIPTION

## 5. DIAGNOSTIC METHOD

### • Abnormality Judgment

Judge NG when the continuous time of completing the malfunction criteria below becomes more than 2.5 seconds.

### • Judgment Value

Malfunction Criteria	Threshold Value
Battery voltage	$\geq 10.9$ V
Ignition switch	ON
After engine starting	1 second or more
Terminal output voltage when ECM sent OFF signals	Low

**Time Needed for Diagnosis:** 2.5 seconds

**Malfunction Indicator Light Illumination:** Illuminates when malfunction occurs in 2 continuous driving cycles.

### • Normality Judgment

Judge OK when the malfunction criteria below are completed.

### • Judgment Value

Malfunction Criteria	Threshold Value
Battery voltage	$\geq 10.9$ V
After engine starting	1 second or more
Terminal output voltage when ECM sent OFF signals	High

## 6. DTC CLEAR CONDITION

- When the OK idling cycle is completed 40 times in a row
- When "Clear Memory" was performed

## 7. MALFUNCTION INDICATOR LIGHT CLEAR CONDITION

- When the OK driving cycle is completed 3 times in a row
- When "Clear Memory" was performed

## 8. FAIL SAFE

None

## 9. ECM OPERATION AT DTC SETTING

Memorize the freeze frame data. (For test mode \$02)

# DIAGNOSTIC TROUBLE CODE (DTC) DETECTING CRITERIA

## GENERAL DESCRIPTION

### CD:DTC P0662 — INTAKE MANIFOLD TUNING VALVE CONTROL CIRCUIT HIGH — BANK 1 — —

#### 1. OUTLINE OF DIAGNOSIS

Detect the open or short circuit of intake manifold tuning valve control.  
Judge NG when the ECM output level is different from actual terminal level.

#### 2. COMPONENT DESCRIPTION

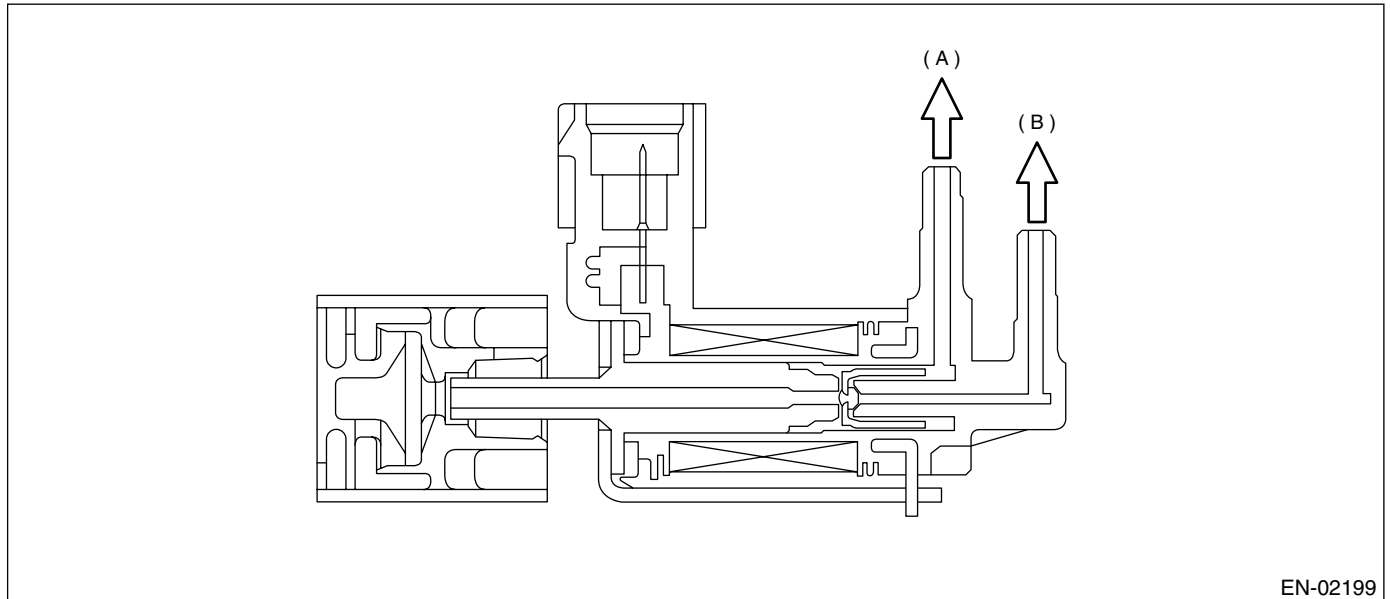

(A) To intake manifold

(B) To variable intake valve

#### 3. ENABLE CONDITION

Secondary Parameters	Enable Conditions
None	

#### 4. GENERAL DRIVING CYCLE

Always perform the diagnosis continuously.

# DIAGNOSTIC TROUBLE CODE (DTC) DETECTING CRITERIA

GENERAL DESCRIPTION

## 5. DIAGNOSTIC METHOD

### • Abnormality Judgment

Judge NG when the cumulative time of completing the malfunction criteria below becomes more than 2.5 seconds.

### • Judgment Value

Malfunction Criteria	Threshold Value
Battery voltage	$\geq 10.9$ V
Ignition switch	ON
After engine starting	1 second or more
Terminal output voltage when ECM sent ON signals	High

**Time Needed for Diagnosis:** 2.5 seconds

**Malfunction Indicator Light Illumination:** Illuminates when malfunction occurs in two continuous drive cycles.

### • Normality Judgment

Judge OK when the malfunction criteria below are completed.

### • Judgment Value

Malfunction Criteria	Threshold Value
Battery voltage	$\geq 10.9$ V
After engine starting	1 second or more
Terminal output voltage when ECM sent OFF signals	Low

## 6. DTC CLEAR CONDITION

- When the OK idling cycle is completed 40 times in a row
- When "Clear Memory" was performed

## 7. MALFUNCTION INDICATOR LIGHT CLEAR CONDITION

- When the OK driving cycle is completed 3 times in a row
- When "Clear Memory" was performed

## 8. FAIL SAFE

None

## 9. ECM OPERATION AT DTC SETTING

Memorize the freeze frame data. (For test mode \$02)

# DIAGNOSTIC TROUBLE CODE (DTC) DETECTING CRITERIA

## GENERAL DESCRIPTION

### CE:DTC P0691 — COOLING FAN 1 CONTROL CIRCUIT LOW —

#### 1. OUTLINE OF DIAGNOSIS

Detect the open or short circuit of the radiator fan circuit.

Judge NG when the ECM output level differs from the actual terminal level.

#### 2. ENABLE CONDITION

Secondary Parameters	Enable Conditions
None	

#### 3. GENERAL DRIVING CYCLE

Always perform the diagnosis continuously.

#### 4. DIAGNOSTIC METHOD

##### • Abnormality Judgment

Judge NG when the cumulative time of completing the malfunction criteria below becomes more than 2.5 seconds.

##### • Judgment Value

Malfunction Criteria	Threshold Value
After starting the engine	1 seconds or more
Engine speed	≥ 500 rpm
Ignition switch	ON
Battery voltage	≥ 10.9 V
Terminal voltage level when ECM transmits OFF signal	Low level

**Time Needed for Diagnosis:** 2.5 seconds

**Malfunction Indicator Light Illumination:** Illuminates when malfunction occurs in 2 continuous driving cycles.

##### • Normality Judgment

Judge OK and clear NG when the malfunction criteria below are completed.

##### • Judgment Value

Malfunction Criteria	Threshold Value
After starting the engine	1 seconds or more
Engine speed	≥ 500 rpm
Ignition switch	ON
Battery voltage	≥ 10.9 V
Terminal voltage level when ECM transmits OFF signal	High level

#### 5. DTC CLEAR CONDITION

- When the OK idling cycle was completed 40 times in a row
- When "Clear Memory" was performed

#### 6. MALFUNCTION INDICATOR LIGHT CLEAR CONDITION

- When the OK driving cycle was completed 3 times in a row
- When "Clear Memory" was performed

#### 7. FAIL SAFE

None

#### 8. ECM OPERATION AT DTC SETTING

Memorize the freeze frame data. (For test mode \$02)

# DIAGNOSTIC TROUBLE CODE (DTC) DETECTING CRITERIA

GENERAL DESCRIPTION

## CF:DTC P0692 — COOLING FAN 1 CONTROL CIRCUIT HIGH —

### 1. OUTLINE OF DIAGNOSIS

Detect the open or short circuit of the radiator fan circuit.

Judge NG when the ECM output level differs from the actual terminal level.

### 2. ENABLE CONDITION

Secondary Parameters	Enable Conditions
None	

### 3. GENERAL DRIVING CYCLE

Always perform the diagnosis continuously.

### 4. DIAGNOSTIC METHOD

#### • Abnormality Judgment

Judge NG when the cumulative time of completing the malfunction criteria below becomes more than 2.5 seconds.

#### • Judgment Value

Malfunction Criteria	Threshold Value
After starting the engine	1 seconds or more
Engine speed	≥ 500 rpm
Ignition switch	ON
Battery voltage	≥ 10.9 V
Terminal voltage level when ECM transmits ON signal	High level

**Time Needed for Diagnosis:** 2.5 seconds

**Malfunction Indicator Light Illumination:** Illuminates when malfunction occurs in 2 continuous driving cycles.

#### • Normality Judgment

Judge OK and clear NG when the malfunction criteria below are completed.

#### • Judgment Value

Malfunction Criteria	Threshold Value
After starting the engine	1 seconds or more
Engine speed	≥ 500 rpm
Ignition switch	ON
Battery voltage	≥ 10.9 V
Terminal voltage level when ECM transmits ON signal	Low level

### 5. DTC CLEAR CONDITION

- When the OK idling cycle was completed 40 times in a row
- When "Clear Memory" was performed

### 6. MALFUNCTION INDICATOR LIGHT CLEAR CONDITION

- When the OK driving cycle was completed 3 times in a row
- When "Clear Memory" was performed

### 7. FAIL SAFE

None

### 8. ECM OPERATION AT DTC SETTING

Memorize the freeze frame data. (For test mode \$02)

# DIAGNOSTIC TROUBLE CODE (DTC) DETECTING CRITERIA

## GENERAL DESCRIPTION

---

### CG:DTC P0703 — TORQUE CONVERTER/BRAKE SWITCH “B” CIRCUIT —

#### 1. OUTLINE OF DIAGNOSIS

Judge NG when the AT brake switch circuit becomes battery short, ground short or open circuit.

#### 2. ENABLE CONDITION

Secondary Parameters	Enable Conditions
Vehicle speed change	30 to 0 km/h (18.6 to 0 MPH) 0 to 30 km/h (0 to 18.6 MPH)

#### 3. GENERAL DRIVING CYCLE

Always perform the diagnosis continuously.

#### 4. DIAGNOSTIC METHOD

##### Judgment Value

Malfunction Criteria	Threshold Value
ON signal	No signal
OFF signal	No signal

**Time Needed for Diagnosis:** 15 times

**Malfunction Indicator Light Illumination:** Illuminates when malfunction occurs in 2 continuous driving cycles.

#### 5. DTC CLEAR CONDITION

- When the OK idling cycle was completed 40 times in a row
- When “Clear Memory” was performed

#### 6. MALFUNCTION INDICATOR LIGHT CLEAR CONDITION

- When the OK driving cycle was completed 3 times in a row
- When “Clear Memory” was performed

#### 7. FAIL SAFE

None

#### 8. ECM OPERATION AT DTC SETTING

Memorize the freeze frame data. (For test mode \$02)

## CH:DTC P0705 — TRANSMISSION RANGE SENSOR CIRCUIT (PRNDL INPUT)

### 1. OUTLINE OF DIAGNOSIS

Judge NG when the “D” range switch becomes ground short or open circuit.

### 2. COMPONENT DESCRIPTION

Inhibitor switch ensures the safety at engine start. This switch is installed to the right side of transmission case, and operated by selector lever. When the selector lever is in the “P” or “N” range, the engine will start because the electric circuit in inhibitor switch is closed and the starter circuit is connected. When the selector lever is in the “R”, “D”, “3”, “2” or “1” range, the electric circuit in inhibitor switch is open; therefore, the engine cannot be cranked. In the “R” range, the back-up light will illuminate because the back-up light circuit in the switch is connected. In addition to the functions above, the inhibitor switch has the circuit which detects the selected range position at the present and transmits the range signal to the TCM.

### 3. ENABLE CONDITION

Secondary Parameters		Enable Conditions
(1)	Shift Vehicle speed	“N” to “3” ≥ 60 km/h (37 MPH)
(2)	Engine speed Battery voltage	> 500 rpm > 10.9 V

### 4. GENERAL DRIVING CYCLE

Always perform the diagnosis continuously.

### 5. DIAGNOSTIC METHOD

#### Judgment Value

	Malfunction Criteria	Threshold Value
(1)	“D” signal continuously	Not detected
(2)	Simultaneous signal	≥ 2

#### Time Needed for Diagnosis:

- 63.75 seconds (1)
- 10 seconds (2)

**Malfunction Indicator Light Illumination:** Illuminates when malfunction occurs in 2 continuous driving cycles.

### 6. DTC CLEAR CONDITION

- When the OK idling cycle was completed 40 times in a row
- When “Clear Memory” was performed

### 7. MALFUNCTION INDICATOR LIGHT CLEAR CONDITION

- When the OK driving cycle was completed 3 times in a row
- When “Clear Memory” was performed

### 8. FAIL SAFE

None

### 9. ECM OPERATION AT DTC SETTING

Memorize the freeze frame data. (For test mode \$02)

# DIAGNOSTIC TROUBLE CODE (DTC) DETECTING CRITERIA

## GENERAL DESCRIPTION

---

### CI: DTC P0710 — TRANSMISSION FLUID TEMPERATURE SENSOR CIRCUIT —

#### 1. OUTLINE OF DIAGNOSIS

- Judge NG when ATF temperature sensor becomes open circuit, battery short or ground short.
- Judge NG when ATF temperature sensor is faulty.

#### 2. COMPONENT DESCRIPTION

ATF temperature sensor is installed to the hydraulic control valve body of transmission as a unit with transmission harness. This sensor detects ATF temperature and outputs it as electric resistance signal.

#### 3. ENABLE CONDITION

Secondary Parameters	Enable Conditions
None	

#### 4. GENERAL DRIVING CYCLE

Always perform the diagnosis continuously.

#### 5. DIAGNOSTIC METHOD

##### Judgment Value

Malfunction Criteria	Threshold Value
Output voltage	$\leq 0.1 \text{ V}$
Output at $\geq 80 \text{ km/h}$ (50 MPH) after 5 minutes from reaching more than 4.8 V	$\geq 4.7 \text{ V}$

**Time Needed for Diagnosis:** 63.75 seconds

**Malfunction Indicator Light Illumination:** Illuminates when malfunction occurs in 2 continuous driving cycles.

#### 6. DTC CLEAR CONDITION

- When the OK idling cycle was completed 40 times in a row
- When "Clear Memory" was performed

#### 7. MALFUNCTION INDICATOR LIGHT CLEAR CONDITION

- When the OK driving cycle was completed 3 times in a row
- When "Clear Memory" was performed

#### 8. FAIL SAFE

Control ATF temperature at a constant temperature 80°C (176°F)

#### 9. ECM OPERATION AT DTC SETTING

Memorize the freeze frame data. (For test mode \$02)



# DIAGNOSTIC TROUBLE CODE (DTC) DETECTING CRITERIA

GENERAL DESCRIPTION

## CJ:DTC P0716 — INPUT/TURBINE SPEED SENSOR CIRCUIT RANGE/PERFORMANCE —

### 1. OUTLINE OF DIAGNOSIS

Judge NG when the turbine speed signal is not transmitted for some reasons.

### 2. COMPONENT DESCRIPTION

Torque converter turbine speed sensor (output shaft speed sensor) is installed to the outside of transmission case. This sensor detects the turbine speed of torque converter by the peripheral speed of high clutch drum connected to input shaft. And then it transmits the sine wave signal (32 pulses per rev.) to TCM. TCM calculates the ratio of the input shaft speed to vehicle speed, and then makes a judgment whether to shift or not.

### 3. ENABLE CONDITION

Secondary Parameters	Enable Conditions
Engine speed	≥ 1500 rpm
Vehicle speed	≥ 40 km/h (25 MPH)
Range switch	“D”, “3”, “2” or “1”

### 4. GENERAL DRIVING CYCLE

Always perform the diagnosis continuously.

### 5. DIAGNOSTIC METHOD

Perform the diagnosis when the conditions below were continued.

- (1) Except “P”, “N”, “R” ranges and inhibitor switch is normal.
- (2) Engine speed is more than 3000 rpm.
- (3) Vehicle speed is 30 km/h (19 MPH) and vehicle speed sensor is normal.
- (4) Turbine speed is more than 600 rpm.

#### Judgment Value

Malfunction Criteria	Threshold Value
Output from turbine shaft speed	< 600 rpm

**Time Needed for Diagnosis:** Perform the diagnosis immediately when the above conditions were continued.

**Malfunction Indicator Light Illumination:** Illuminates when malfunction occurs in 2 continuous driving cycles.

### 6. DTC CLEAR CONDITION

- When the OK idling cycle was completed 40 times in a row
- When “Clear Memory” was performed

### 7. MALFUNCTION INDICATOR LIGHT CLEAR CONDITION

- When the OK driving cycle was completed 3 times in a row
- When “Clear Memory” was performed

### 8. FAIL SAFE

None

### 9. ECM OPERATION AT DTC SETTING

Memorize the freeze frame data. (For test mode \$02)

# DIAGNOSTIC TROUBLE CODE (DTC) DETECTING CRITERIA

## GENERAL DESCRIPTION

---

### CK:DTC P0720 — OUTPUT SPEED SENSOR CIRCUIT —

#### 1. OUTLINE OF DIAGNOSIS

Judge NG when an abnormal large signal is input to the front vehicle speed sensor, or no signal is input to the rear vehicle speed sensor.

#### 2. COMPONENT DESCRIPTION

This vehicle speed sensor (output shaft speed sensor) is installed to the outside of transmission case. This sensor detects the front wheel speed, and transmits the sine wave signal (32 pulses per rev.) to TCM. TCM converts the signal to pulse signal, and transmits to both of the ECM and the combination meter.

#### 3. ENABLE CONDITION

Secondary Parameters	Enable Conditions
Vehicle speed	≥ 20 km/h (12 MPH)

#### 4. GENERAL DRIVING CYCLE

Always perform the diagnosis with more than 20 km/h (12 MPH) vehicle speed.

#### 5. DIAGNOSTIC METHOD

##### Judgment Value

Malfunction Criteria	Threshold Value
Number of speed sensor signals at every 1 second	≥ 4698 or no signal

**Time Needed for Diagnosis:** 63.75 seconds

**Malfunction Indicator Light Illumination:** Illuminates when malfunction occurs in 2 continuous driving cycles.

#### 6. DTC CLEAR CONDITION

- When the OK idling cycle was completed 40 times in a row
- When "Clear Memory" was performed

#### 7. MALFUNCTION INDICATOR LIGHT CLEAR CONDITION

- When the OK driving cycle was completed 3 times in a row
- When "Clear Memory" was performed

#### 8. FAIL SAFE

- Use the normal vehicle speed sensor signal when either of them is normal.
- Use the vehicle speed calculated from the current gear position and turbine speed when both front and rear wheels are troubled.

#### 9. ECM OPERATION AT DTC SETTING

Memorize the freeze frame data. (For test mode \$02)

# DIAGNOSTIC TROUBLE CODE (DTC) DETECTING CRITERIA

GENERAL DESCRIPTION

## CL:DTC P0726 — ENGINE SPEED INPUT CIRCUIT RANGE/PERFORMANCE —

### 1. OUTLINE OF DIAGNOSIS

Judge NG when the engine speed is not input in the status of running the engine.

### 2. COMPONENT DESCRIPTION

Engine speed sensor is installed to the outside of engine body and crank part. This sensor detects the crank speed, and transmits the sine wave signal (2 pulses per rev.) to TCM.

### 3. ENABLE CONDITION

Secondary Parameters	Enable Conditions
Output from mass air flow sensor	> 1.0 V

### 4. GENERAL DRIVING CYCLE

Always perform the diagnosis continuously.

### 5. DIAGNOSTIC METHOD

#### Judgment Value

Malfunction Criteria	Threshold Value
Engine speed	$\leq 400$ rpm

**Time Needed for Diagnosis:** 63.75 seconds

**Malfunction Indicator Light Illumination:** Illuminates when malfunction occurs in 2 continuous driving cycles.

### 6. DTC CLEAR CONDITION

- When the OK idling cycle was completed 40 times in a row
- When "Clear Memory" was performed

### 7. MALFUNCTION INDICATOR LIGHT CLEAR CONDITION

- When the OK driving cycle was completed 3 times in a row
- When "Clear Memory" was performed

### 8. FAIL SAFE

None

### 9. ECM OPERATION AT DTC SETTING

Memorize the freeze frame data. (For test mode \$02)

# DIAGNOSTIC TROUBLE CODE (DTC) DETECTING CRITERIA

## GENERAL DESCRIPTION

---

### CM:DTC P0731 — GEAR 1 INCORRECT RATIO —

#### 1. OUTLINE OF DIAGNOSIS

Judge NG when the expected present gear is different from the actual gear.

#### 2. ENABLE CONDITION

Secondary Parameters	Enable Conditions
Throttle angle	$\geq 15^\circ$
Vehicle speed	$\geq 10$ km/h (6 MPH)
Range switch	"D", "3", "2" or "1"
Upshift or downshift events	Not in operation

#### 3. GENERAL DRIVING CYCLE

Always perform the diagnosis with less than 10 km/h (6 MPH) vehicle speed.

#### 4. DIAGNOSTIC METHOD

Perform the diagnosis when the conditions below are not completed for more than 40 milliseconds on normal control.

- (1) Vehicle speed is more than 10 km/h (6 MPH).
- (2) Throttle sensor is more than a certain angle.
- (3) Shifted to "D", "3", "2" or "1" range, and range signal is normal.
- (4) More than 1 second passed after shift change finished.

#### Judgment Value

Malfunction Criteria	Threshold Value
GR/(1st gear ratio) where, GR = (vehicle speed sensor 1 output)/ (turbine shaft speed sensor output)	$> 110\%$ or $< 90\%$

**Time Needed for Diagnosis:** 3 seconds

**Malfunction Indicator Light Illumination:** Illuminates when malfunction occurs in 2 continuous driving cycles.

#### 5. DTC CLEAR CONDITION

- When the OK idling cycle was completed 40 times in a row
- When "Clear Memory" was performed

#### 6. MALFUNCTION INDICATOR LIGHT CLEAR CONDITION

- When the OK driving cycle was completed 3 times in a row
- When "Clear Memory" was performed

#### 7. FAIL SAFE

None

#### 8. ECM OPERATION AT DTC SETTING

Memorize the freeze frame data. (For test mode \$02)

# DIAGNOSTIC TROUBLE CODE (DTC) DETECTING CRITERIA

GENERAL DESCRIPTION

## CN:DTC P0732 — GEAR 2 INCORRECT RATIO —

### 1. OUTLINE OF DIAGNOSIS

Judge NG when the expected present gear is different from the actual gear.

### 2. ENABLE CONDITION

Secondary Parameters	Enable Conditions
Throttle angle	$\geq 15^\circ$
Vehicle speed	$\geq 10$ km/h (6 MPH)
Range switch	"D", "3", "2" or "1"
Upshift or downshift events	Not in operation

### 3. GENERAL DRIVING CYCLE

Always perform the diagnosis with less than 10 km/h (6 MPH) vehicle speeds.

### 4. DIAGNOSTIC METHOD

Perform the diagnosis when the conditions below are not completed for more than 40 milliseconds on normal control.

- (1) Vehicle speed is more than 10 km/h (6 MPH).
- (2) Throttle sensor is more than a certain angle.
- (3) Shifted to "D", "3", "2" or "1" range, and range signal is normal.
- (4) More than 1 second passed after shift change finished.

#### Judgment Value

Malfunction Criteria	Threshold Value
GR/(2nd gear ratio) Where, GR = (Vehicle speed sensor 1 output)/ (Turbine shaft speed sensor output)	$> 110\%$ or $< 90\%$

**Time Needed for Diagnosis:** 3 seconds

**Malfunction Indicator Light Illumination:** Illuminates when malfunction occurs in 2 continuous driving cycles.

### 5. DTC CLEAR CONDITION

- When the OK idling cycle was completed 40 times in a row
- When "Clear Memory" was performed

### 6. MALFUNCTION INDICATOR LIGHT CLEAR CONDITION

- When the OK driving cycle was completed 3 times in a row
- When "Clear Memory" was performed

### 7. FAIL SAFE

None

### 8. ECM OPERATION AT DTC SETTING

Memorize the freeze frame data. (For test mode \$02)

# DIAGNOSTIC TROUBLE CODE (DTC) DETECTING CRITERIA

## GENERAL DESCRIPTION

### CO:DTC P0733 — GEAR 3 INCORRECT RATIO —

#### 1. OUTLINE OF DIAGNOSIS

Judge NG when the expected present gear is different from the actual gear.

#### 2. ENABLE CONDITION

Secondary Parameters	Enable Conditions
Throttle angle	$\geq 15^\circ$
Vehicle speed	$\geq 10$ km/h (6 MPH)
Range switch	"D", "3", "2" or "1"
Upshift or downshift events	Not in operation

#### 3. GENERAL DRIVING CYCLE

Always perform the diagnosis with less than 10 km/h (6 MPH) vehicle speeds.

#### 4. DIAGNOSTIC METHOD

Perform the diagnosis when the conditions below are not completed for more than 40 milliseconds on normal control.

- (1) Vehicle speed is more than 10 km/h (6 MPH).
- (2) Throttle sensor is more than a certain angle.
- (3) Shifted to "D", "3", "2" or "1" range, and range signal is normal.
- (4) More than 1 second passed after shift change finished.

#### Judgment Value

Malfunction Criteria	Threshold Value
GR/(3rd gear ratio) Where, GR = (Vehicle speed sensor 1 output)/ (Turbine shaft speed sensor output)	$> 110\%$ or $< 90\%$

**Time Needed for Diagnosis:** 3 seconds

**Malfunction Indicator Light Illumination:** Illuminates when malfunction occurs in 2 continuous driving cycles.

#### 5. DTC CLEAR CONDITION

- When the OK idling cycle was completed 40 times in a row
- When "Clear Memory" was performed

#### 6. MALFUNCTION INDICATOR LIGHT CLEAR CONDITION

- When the OK driving cycle was completed 3 times in a row
- When "Clear Memory" was performed

#### 7. FAIL SAFE

None

#### 8. ECM OPERATION AT DTC SETTING

Memorize the freeze frame data. (For test mode \$02)

# DIAGNOSTIC TROUBLE CODE (DTC) DETECTING CRITERIA

GENERAL DESCRIPTION

## CP:DTC P0734 — GEAR 4 INCORRECT RATIO —

### 1. OUTLINE OF DIAGNOSIS

Judge NG when the expected present gear is different from the actual gear.

### 2. ENABLE CONDITION

Secondary Parameters	Enable Conditions
Throttle angle	≥ 15°
Vehicle speed	≥ 10 km/h (6 MPH)
Range switch	“D”, “3”, “2” or “1”
Upshift or downshift events	Not in operation

### 3. GENERAL DRIVING CYCLE

Always perform the diagnosis with less than 10 km/h (6 MPH) vehicle speeds.

### 4. DIAGNOSTIC METHOD

Perform the diagnosis when the conditions below are not completed for more than 40 milliseconds on normal control.

- (1) Vehicle speed is more than 10 km/h (6 MPH).
- (2) Throttle sensor is more than a certain angle.
- (3) Shifted to “D”, “3”, “2” or “1” range, and range signal is normal.
- (4) More than 1 second passed after shift change finished.

#### Judgment Value

Malfunction Criteria	Threshold Value
GR/(4th gear ratio) Where, GR = (Vehicle speed sensor 1 output)/ (Turbine shaft speed sensor output)	> 110% or < 90%

**Time Needed for Diagnosis:** 3 seconds

**Malfunction Indicator Light Illumination:** Illuminates when malfunction occurs in 2 continuous driving cycles.

### 5. DTC CLEAR CONDITION

- When the OK idling cycle was completed 40 times in a row
- When “Clear Memory” was performed

### 6. MALFUNCTION INDICATOR LIGHT CLEAR CONDITION

- When the OK driving cycle was completed 3 times in a row
- When “Clear Memory” was performed

### 7. FAIL SAFE

None

### 8. ECM OPERATION AT DTC SETTING

Memorize the freeze frame data. (For test mode \$02)

# DIAGNOSTIC TROUBLE CODE (DTC) DETECTING CRITERIA

## GENERAL DESCRIPTION

---

### CQ:DTC P0741 — TORQUE CONVERTER CLUTCH CIRCUIT PERFORMANCE OR STUCK OFF —

#### 1. OUTLINE OF DIAGNOSIS

Judge NG when the engine speed is different from the turbine speed for some reasons at AT lock-up.

#### 2. ENABLE CONDITION

Secondary Parameters	Enable Conditions
In 4th gear position, duty ratio for duty solenoid valve	$\geq 90\%$

#### 3. GENERAL DRIVING CYCLE

Always perform the diagnosis continuously.

#### 4. DIAGNOSTIC METHOD

##### Judgment Value

Malfunction Criteria	Threshold Value
Engine speed $\geq$ (output shaft speed $\times$ 4th gear ratio $\times$ 9/8)	

**Time Needed for Diagnosis:** 10.2 seconds

**Malfunction Indicator Light Illumination:** Illuminates when malfunction occurs in 2 continuous driving cycles.

#### 5. DTC CLEAR CONDITION

- When the OK idling cycle was completed 40 times in a row
- When "Clear Memory" was performed

#### 6. MALFUNCTION INDICATOR LIGHT CLEAR CONDITION

- When the OK driving cycle was completed 3 times in a row
- When "Clear Memory" was performed

#### 7. FAIL SAFE

Not allowed to lock up.

#### 8. ECM OPERATION AT DTC SETTING

Memorize the freeze frame data. (For test mode \$02)



# DIAGNOSTIC TROUBLE CODE (DTC) DETECTING CRITERIA

GENERAL DESCRIPTION

## CR:DTC P0743 — TORQUE CONVERTER CLUTCH CIRCUIT ELECTRICAL —

### 1. OUTLINE OF DIAGNOSIS

Judge NG when the lock-up duty solenoid becomes battery short, ground short or open circuit.

### 2. COMPONENT DESCRIPTION

Lock-up duty solenoid is installed to the transmission hydraulic control valve body. The duty ratio is controlled by the signal from TCM. This allows the lock-up clutch to be connected or released smoothly by controlling the lock-up control valve.

### 3. ENABLE CONDITION

Secondary Parameters	Enable Conditions
None	

### 4. GENERAL DRIVING CYCLE

Always perform the diagnosis continuously.

### 5. DIAGNOSTIC METHOD

#### Judgment Value

Malfunction Criteria	Threshold Value
Vc at "ON" signal from ECM	Low level
Vc at "OFF" signal from ECM	High level

**Time Needed for Diagnosis:** 0.14 seconds

**Malfunction Indicator Light Illumination:** Illuminates when malfunction occurs in 2 continuous driving cycles.

### 6. DTC CLEAR CONDITION

- When the OK idling cycle was completed 40 times in a row
- When "Clear Memory" was performed

### 7. MALFUNCTION INDICATOR LIGHT CLEAR CONDITION

- When the OK driving cycle was completed 3 times in a row
- When "Clear Memory" was performed

### 8. FAIL SAFE

None

### 9. ECM OPERATION AT DTC SETTING

Memorize the freeze frame data. (For test mode \$02)

# DIAGNOSTIC TROUBLE CODE (DTC) DETECTING CRITERIA

## GENERAL DESCRIPTION

---

### CS:DTC P0748 — PRESSURE CONTROL SOLENOID “A” ELECTRICAL —

#### 1. OUTLINE OF DIAGNOSIS

Judge NG when the line pressure duty solenoid becomes battery short, ground short or open circuit.

#### 2. COMPONENT DESCRIPTION

Line pressure duty solenoid is installed to the transmission hydraulic control valve body. The duty ratio is controlled by the signal from TCM. This allows controlling the pressure modifier valve and accumulator control valve A, and allows the line pressure to be adjusted to the pressure appropriate for driving condition.

#### 3. ENABLE CONDITION

Secondary Parameters	Enable Conditions
None	

#### 4. GENERAL DRIVING CYCLE

Always perform the diagnosis continuously.

#### 5. DIAGNOSTIC METHOD

##### Judgment Value

Malfunction Criteria	Threshold Value
Vc at “ON” signal from ECM	Low level
Vc at “OFF” signal from ECM	High level

**Time Needed for Diagnosis:** 0.14 seconds

**Malfunction Indicator Light Illumination:** Illuminates when malfunction occurs in 2 continuous driving cycles.

#### 6. DTC CLEAR CONDITION

- When the OK idling cycle was completed 40 times in a row
- When “Clear Memory” was performed

#### 7. MALFUNCTION INDICATOR LIGHT CLEAR CONDITION

- When the OK driving cycle was completed 3 times in a row
- When “Clear Memory” was performed

#### 8. FAIL SAFE

Control the shift to be fixed in 3rd gear.

#### 9. ECM OPERATION AT DTC SETTING

Memorize the freeze frame data. (For test mode \$02)

# DIAGNOSTIC TROUBLE CODE (DTC) DETECTING CRITERIA

GENERAL DESCRIPTION

## CT:DTC P0753 — SHIFT SOLENOID “A” ELECTRICAL —

### 1. OUTLINE OF DIAGNOSIS

Judge NG when the shift solenoid 1 becomes battery short, ground short or open circuit.

### 2. COMPONENT DESCRIPTION

Shift solenoid 1 Shift solenoid is installed to the transmission hydraulic control valve body. This solenoid is switched on or off by the signal from TCM. Gear positions will change depending on the solenoid condition which is ON or OFF.

### 3. ENABLE CONDITION

Secondary Parameters	Enable Conditions
None	

### 4. GENERAL DRIVING CYCLE

Always perform the diagnosis continuously.

### 5. DIAGNOSTIC METHOD

#### Judgment Value

Malfunction Criteria	Threshold Value
Collector voltage of transistor (Vc) for solenoid valve is inconsistent with signal from ECM	

**Time Needed for Diagnosis:** 30 milliseconds

**Malfunction Indicator Light Illumination:** Illuminates when malfunction occurs in 2 continuous driving cycles.

### 6. DTC CLEAR CONDITION

- When the OK idling cycle was completed 40 times in a row
- When “Clear Memory” was performed

### 7. MALFUNCTION INDICATOR LIGHT CLEAR CONDITION

- When the OK driving cycle was completed 3 times in a row
- When “Clear Memory” was performed

### 8. FAIL SAFE

Control the shift to be fixed in 3rd gear.

### 9. ECM OPERATION AT DTC SETTING

Memorize the freeze frame data. (For test mode \$02)

# DIAGNOSTIC TROUBLE CODE (DTC) DETECTING CRITERIA

## GENERAL DESCRIPTION

---

### CU:DTC P0758 — SHIFT SOLENOID “B” ELECTRICAL —

#### 1. OUTLINE OF DIAGNOSIS

Judge NG when the shift solenoid 2 becomes battery short, ground short or open circuit.

#### 2. COMPONENT DESCRIPTION

Shift solenoid 2 Shift solenoid is installed to the transmission hydraulic control valve body. This solenoid is switched on or off by the signal from TCM. Gear positions will change depending on the solenoid condition which is ON or OFF.

#### 3. ENABLE CONDITION

Secondary Parameters	Enable Conditions
None	

#### 4. GENERAL DRIVING CYCLE

Always perform the diagnosis continuously.

#### 5. DIAGNOSTIC METHOD

##### Judgment Value

Malfunction Criteria	Threshold Value
Vc for solenoid valve is inconsistent with signal from ECM	

**Time Needed for Diagnosis:** 30 milliseconds

**Malfunction Indicator Light Illumination:** Illuminates when malfunction occurs in 2 continuous driving cycles.

#### 6. DTC CLEAR CONDITION

- When the OK idling cycle was completed 40 times in a row
- When “Clear Memory” was performed

#### 7. MALFUNCTION INDICATOR LIGHT CLEAR CONDITION

- When the OK driving cycle was completed 3 times in a row
- When “Clear Memory” was performed

#### 8. FAIL SAFE

Control the shift to be fixed in 3rd gear.

#### 9. ECM OPERATION AT DTC SETTING

Memorize the freeze frame data. (For test mode \$02)

# DIAGNOSTIC TROUBLE CODE (DTC) DETECTING CRITERIA

GENERAL DESCRIPTION

## CV:DTC P0771 — SHIFT SOLENOID “E” PERFORMANCE OR STUCK OFF —

### 1. OUTLINE OF DIAGNOSIS

Judge NG when the low clutch timing solenoid becomes battery short, ground short or open circuit.

### 2. COMPONENT DESCRIPTION

Low clutch timing solenoid Low clutch timing solenoid is installed to the transmission hydraulic control valve body. This solenoid is switched on or off by the signal from TCM. This allows controlling the low clutch timing valve B and reverse inhibitor valve.

### 3. ENABLE CONDITION

Secondary Parameters	Enable Conditions
None	

### 4. GENERAL DRIVING CYCLE

Always perform the diagnosis continuously.

### 5. DIAGNOSTIC METHOD

#### Judgment Value

Malfunction Criteria	Threshold Value
Vc at “ON” signal from ECM	Low level
Vc at “OFF” signal from ECM	High level

**Time Needed for Diagnosis:** 30 milliseconds

**Malfunction Indicator Light Illumination:** Illuminates when malfunction occurs in 2 continuous driving cycles.

### 6. DTC CLEAR CONDITION

- When the OK idling cycle was completed 40 times in a row
- When “Clear Memory” was performed

### 7. MALFUNCTION INDICATOR LIGHT CLEAR CONDITION

- When the OK driving cycle was completed 3 times in a row
- When “Clear Memory” was performed

### 8. FAIL SAFE

None

### 9. ECM OPERATION AT DTC SETTING

Memorize the freeze frame data. (For test mode \$02)

# DIAGNOSTIC TROUBLE CODE (DTC) DETECTING CRITERIA

## GENERAL DESCRIPTION

---

### CW:DTC P0778 — PRESSURE CONTROL SOLENOID “B” ELECTRICAL —

#### 1. OUTLINE OF DIAGNOSIS

Judge NG when the 2-4 brake duty solenoid becomes battery short, ground short or open circuit.

#### 2. COMPONENT DESCRIPTION

2-4 brake duty solenoid is installed to the transmission hydraulic control valve body. The duty ratio is controlled by the signal from TCM. This solenoid decreases the change gear shock by adjusting the 2-4 brake pressure during 2-4 brake operation.

#### 3. ENABLE CONDITION

Secondary Parameters	Enable Conditions
None	

#### 4. GENERAL DRIVING CYCLE

Always perform the diagnosis continuously.

#### 5. DIAGNOSTIC METHOD

##### Judgment Value

Malfunction Criteria	Threshold Value
Vc at “ON” signal from ECM	Low level
Vc at “OFF” signal from ECM	High level

**Time Needed for Diagnosis:** 0.14 seconds

**Malfunction Indicator Light Illumination:** Illuminates when malfunction occurs in 2 continuous driving cycles.

#### 6. DTC CLEAR CONDITION

- When the OK idling cycle was completed 40 times in a row
- When “Clear Memory” was performed

#### 7. MALFUNCTION INDICATOR LIGHT CLEAR CONDITION

- When the OK driving cycle was completed 3 times in a row
- When “Clear Memory” was performed

#### 8. FAIL SAFE

Control the shift to be fixed in 3rd gear.

#### 9. ECM OPERATION AT DTC SETTING

Memorize the freeze frame data. (For test mode \$02)

# DIAGNOSTIC TROUBLE CODE (DTC) DETECTING CRITERIA

GENERAL DESCRIPTION

## CX:DTC P0785 — SHIFT/TIMING SOLENOID —

### 1. OUTLINE OF DIAGNOSIS

Judge NG when the 2-4 brake timing solenoid becomes battery short, ground short or open circuit.

### 2. COMPONENT DESCRIPTION

2-4 brake timing solenoid is installed to the transmission hydraulic control valve body. This solenoid is switched on or off by the signal from TCM. This allows controlling the 2-4 brake timing valve B and decreases the change gear shock.

### 3. ENABLE CONDITION

Secondary Parameters	Enable Conditions
None	

### 4. GENERAL DRIVING CYCLE

Always perform the diagnosis continuously.

### 5. DIAGNOSTIC METHOD

#### Judgment Value

Malfunction Criteria	Threshold Value
Vc at "ON" signal from ECM	Low level
Vc at "OFF" signal from ECM	High level

**Time Needed for Diagnosis:** 30 milliseconds

**Malfunction Indicator Light Illumination:** Illuminates when malfunction occurs in 2 continuous driving cycles.

### 6. DTC CLEAR CONDITION

- When the OK idling cycle was completed 40 times in a row
- When "Clear Memory" was performed

### 7. MALFUNCTION INDICATOR LIGHT CLEAR CONDITION

- When the OK driving cycle was completed 3 times in a row
- When "Clear Memory" was performed

### 8. FAIL SAFE

None

### 9. ECM OPERATION AT DTC SETTING

Memorize the freeze frame data. (For test mode \$02)

# DIAGNOSTIC TROUBLE CODE (DTC) DETECTING CRITERIA

## GENERAL DESCRIPTION

---

### CY:DTC P0851 — NEUTRAL SWITCH INPUT CIRCUIT LOW —

#### 1. OUTLINE OF DIAGNOSIS

Detect the open or short circuit of the neutral SW.

Judge NG when the ECM neutral terminal input differs from the reception data from TCM.

#### 2. ENABLE CONDITION

Secondary Parameters	Enable Conditions
Ignition switch	ON
Battery voltage	$\geq 10.9$ V
After starting the engine	2 seconds or more
Starter switch	OFF

#### 3. GENERAL DRIVING CYCLE

Perform the diagnosis continuously in 2 seconds or more after starting the engine.

#### 4. DIAGNOSTIC METHOD

Judge NG when the number of times of completing the malfunction criteria below becomes more than 10 times. Judge OK and clear NG when the malfunction criteria below are not completed.

##### Judgment Value

Malfunction Criteria	Threshold Value
Neutral switch signal when park/neutral = "ON" & any other switches = "OFF" on AT	OFF

**Time Needed for Diagnosis:** 10 times

**Malfunction Indicator Light Illumination:** Illuminates when malfunction occurs in 2 continuous driving cycles.

#### 5. DTC CLEAR CONDITION

- When the OK idling cycle was completed 40 times in a row
- When "Clear Memory" was performed

#### 6. MALFUNCTION INDICATOR LIGHT CLEAR CONDITION

- When the OK driving cycle was completed 3 times in a row
- When "Clear Memory" was performed

#### 7. FAIL SAFE

None

#### 8. ECM OPERATION AT DTC SETTING

Memorize the freeze frame data. (For test mode \$02)



# DIAGNOSTIC TROUBLE CODE (DTC) DETECTING CRITERIA

GENERAL DESCRIPTION

## CZ:DTC P0852 — NEUTRAL SWITCH INPUT CIRCUIT HIGH —

### 1. OUTLINE OF DIAGNOSIS

Detect the open or short circuit of the neutral SW.

Judge NG when the ECM neutral terminal input differs from the reception data from TCM.

### 2. ENABLE CONDITION

Secondary Parameters	Enable Conditions
Ignition switch	ON
Battery voltage	$\geq 10.9$ V
After starting the engine	2 seconds or more
Starter switch	OFF

### 3. GENERAL DRIVING CYCLE

Perform the diagnosis continuously in 2 seconds or more after starting the engine.

### 4. DIAGNOSTIC METHOD

Judge NG when the number of times of completing the malfunction criteria below becomes more than 10 times. Judge OK and clear NG when the malfunction criteria below are not completed.

#### Judgment Value

Malfunction Criteria	Threshold Value
Neutral switch signal when park/neutral = "OFF" & any other switches = "ON" on AT	ON

**Time Needed for Diagnosis:** 10 times

**Malfunction Indicator Light Illumination:** Illuminates when malfunction occurs in 2 continuous driving cycles.

### 5. DTC CLEAR CONDITION

- When the OK idling cycle was completed 40 times in a row
- When "Clear Memory" was performed

### 6. MALFUNCTION INDICATOR LIGHT CLEAR CONDITION

- When the OK driving cycle was completed 3 times in a row
- When "Clear Memory" was performed

### 7. FAIL SAFE

None

### 8. ECM OPERATION AT DTC SETTING

Memorize the freeze frame data. (For test mode \$02)

# DIAGNOSTIC TROUBLE CODE (DTC) DETECTING CRITERIA

## GENERAL DESCRIPTION

---

### DA:DTC P0864 — TCM COMMUNICATION CIRCUIT RANGE/PERFORMANCE —

#### 1. OUTLINE OF DIAGNOSIS

Detect malfunction of communication of AT diagnosis.  
Judge NG when communication format is disagreement.

#### 2. ENABLE CONDITION

Secondary Parameters	Enable Conditions
Ignition switch	ON
Battery voltage	$\geq 10.9$ V
Engine speed	$\geq 500$ rpm

#### 3. GENERAL DRIVING CYCLE

Perform diagnosis during the vehicle running.

#### 4. DIAGNOSTIC METHOD

Judge NG when the continuous time of completing the malfunction criteria below becomes more than the time needed for diagnosis (60 seconds). Judge OK and clear NG when receiving normal data.

##### Judgment Value

Malfunction Criteria	Threshold Value
AT malfunction data reception control	Not receive normal data

**Time Needed for Diagnosis:** 60 seconds

**Malfunction Indicator Light Illumination:** Illuminates when malfunction occurs in 2 continuous driving cycles.

#### 5. DTC CLEAR CONDITION

- When the OK idling cycle was completed 40 times in a row
- When "Clear Memory" was performed

#### 6. MALFUNCTION INDICATOR LIGHT CLEAR CONDITION

- When the OK driving cycle was completed 3 times in a row
- When "Clear Memory" was performed

#### 7. FAIL SAFE

None

#### 8. ECM OPERATION AT DTC SETTING

Memorize the freeze frame data. (For test mode \$02)

# DIAGNOSTIC TROUBLE CODE (DTC) DETECTING CRITERIA

GENERAL DESCRIPTION

## DB:DTC P0865 — TCM COMMUNICATION CIRCUIT LOW —

### 1. OUTLINE OF DIAGNOSIS

Detect open or short circuit in AT diagnosis line.

Judge NG when the AT diagnosis input line signal remains Low.

### 2. COMPONENT DESCRIPTION

Data frame as “Start signal (Low\_40 ms + High\_20 ms) → Data → End signal” is transmitted every approx. 1 second.

### 3. ENABLE CONDITION

Secondary Parameters	Enable Conditions
Ignition switch	ON
Battery voltage	≥ 10.9 V
Engine speed	≥ 500 rpm

### 4. GENERAL DRIVING CYCLE

Perform diagnosis during the vehicle running.

### 5. DIAGNOSTIC METHOD

Judge NG when the continuous time of completing the malfunction criteria below becomes more than the time needed for diagnosis (3 seconds). Judge OK and clear NG when the malfunction criteria below are not completed.

#### Judgment Value

Malfunction Criteria	Threshold Value
AT diagnosis input line signal	Low

**Time Needed for Diagnosis:** 3 seconds

**Malfunction Indicator Light Illumination:** Illuminates when malfunction occurs in two continuous drive cycles.

### 6. DTC CLEAR CONDITION

- When the OK idling cycle was completed 40 times in a row
- When “Clear Memory” was performed

### 7. MALFUNCTION INDICATOR LIGHT CLEAR CONDITION

- When the OK driving cycle was completed 3 times in a row
- When “Clear Memory” was performed

### 8. FAIL SAFE

None

### 9. ECM OPERATION AT DTC SETTING

Memorize the freeze frame data. (For test mode \$02)

# DIAGNOSTIC TROUBLE CODE (DTC) DETECTING CRITERIA

## GENERAL DESCRIPTION

---

### DC:DTC P0866 — TCM COMMUNICATION CIRCUIT HIGH —

#### 1. OUTLINE OF DIAGNOSIS

Detect open or short circuit in AT diagnosis line.

Judge NG when the AT diagnosis input line signal remains High.

#### 2. COMPONENT DESCRIPTION

Data frame as “Start signal (Low\_40 ms + High\_20 ms) → Data → End signal” is transmitted every approx. 1 second.

#### 3. ENABLE CONDITION

Secondary Parameters	Enable Conditions
Ignition switch	ON
Battery voltage	≥ 10.9 V
Engine speed	≥ 500 rpm

#### 4. GENERAL DRIVING CYCLE

Perform diagnosis during the vehicle running.

#### 5. DIAGNOSTIC METHOD

Judge NG when the continuous time until completing the malfunction criteria below becomes more than the time needed for diagnosis (3 seconds). Judge OK and clear NG when the malfunction criteria below are not completed.

##### Judgment Value

Malfunction Criteria	Threshold Value
AT diagnosis input line signal	High

**Time Needed for Diagnosis:** 3 seconds

**Malfunction Indicator Light Illumination:** Illuminates when malfunction occurs in two continuous drive cycles.

#### 6. DTC CLEAR CONDITION

- When the OK idling cycle was completed 40 times in a row
- When “Clear Memory” was performed

#### 7. MALFUNCTION INDICATOR LIGHT CLEAR CONDITION

- When the OK driving cycle was completed 3 times in a row
- When “Clear Memory” was performed

#### 8. FAIL SAFE

None

#### 9. ECM OPERATION AT DTC SETTING

Memorize the freeze frame data. (For test mode \$02)

# DIAGNOSTIC TROUBLE CODE (DTC) DETECTING CRITERIA

GENERAL DESCRIPTION

## DD:DTC P1110 — ATMOSPHERIC PRESSURE SENSOR CIRCUIT MALFUNCTION (LOW INPUT) —

### 1. OUTLINE OF DIAGNOSIS

Detect the open or short circuit of atmospheric pressure sensor.  
Judge NG when out of the standard value.

### 2. COMPONENT DESCRIPTION

Atmospheric pressure sensor is built in ECM.

### 3. ENABLE CONDITION

Secondary Parameters	Enable Conditions
None	

### 4. GENERAL DRIVING CYCLE

Always perform the diagnosis continuously.

### 5. DIAGNOSTIC METHOD

#### • Abnormality Judgment

Judge NG when the continuous time of completing the malfunction criteria below becomes more than 0.5 seconds.

#### • Judgment Value

Malfunction Criteria	Threshold Value
Ignition switch	ON
Output voltage	< 1.0 V

**Time Needed for Diagnosis:** 0.5 seconds

**Malfunction Indicator Light Illumination:** Illuminates as soon as malfunction occurs.

#### • Normality Judgment

Judge OK and clear the NG when the malfunction criteria below are completed.

#### • Judgment Value

Malfunction Criteria	Threshold Value
Ignition switch	ON
Output voltage	$\geq 1.0$ V

### 6. DTC CLEAR CONDITION

- When the OK idling cycle was completed 40 times in a row
- When "Clear Memory" was performed

### 7. MALFUNCTION INDICATOR LIGHT CLEAR CONDITION

- When the OK driving cycle was completed 3 times in a row
- When "Clear Memory" was performed

### 8. FAIL SAFE

Atmospheric pressure sensor process: Fix the atmospheric pressure to 101.3 kPa (760 mmHg, 29.9 inHg).

### 9. ECM OPERATION AT DTC SETTING

Memorize the freeze frame data. (For test mode \$02)

# DIAGNOSTIC TROUBLE CODE (DTC) DETECTING CRITERIA

## GENERAL DESCRIPTION

### DE:DTC P1111 — ATMOSPHERIC PRESSURE SENSOR CIRCUIT MALFUNCTION (HIGH INPUT) —

#### 1. OUTLINE OF DIAGNOSIS

Detect the open or short circuit of atmospheric pressure sensor.  
Judge NG when out of the standard value.

#### 2. COMPONENT DESCRIPTION

Atmospheric pressure sensor is built in ECM.

#### 3. ENABLE CONDITION

Secondary Parameters	Enable Conditions
None	

#### 4. GENERAL DRIVING CYCLE

Always perform the diagnosis continuously.

#### 5. DIAGNOSTIC METHOD

##### • Abnormality Judgment

Judge NG when the continuous time of completing the malfunction criteria below becomes more than 0.5 seconds.

##### • Judgment Value

Malfunction Criteria	Threshold Value
Ignition switch	ON
Output voltage	$\geq 4.7$ V

**Time Needed for Diagnosis:** 0.5 seconds

**Malfunction Indicator Light Illumination:** Illuminates as soon as malfunction occurs.

##### • Normality Judgment

Judge OK and clear the NG when the malfunction criteria below are completed.

##### • Judgment Value

Malfunction Criteria	Threshold Value
Ignition switch	ON
Output voltage	$< 4.7$ V

#### 6. DTC CLEAR CONDITION

- When the OK idling cycle was completed 40 times in a row
- When "Clear Memory" was performed

#### 7. MALFUNCTION INDICATOR LIGHT CLEAR CONDITION

- When the OK driving cycle was completed 3 times in a row
- When "Clear Memory" was performed

#### 8. FAIL SAFE

Atmospheric pressure sensor process: Fix the atmospheric pressure to 101.3 kPa (760 mmHg, 29.9 inHg).

#### 9. ECM OPERATION AT DTC SETTING

Memorize the freeze frame data. (For test mode \$02)

# DIAGNOSTIC TROUBLE CODE (DTC) DETECTING CRITERIA

GENERAL DESCRIPTION

---

MEMO:

# DIAGNOSTIC TROUBLE CODE (DTC) DETECTING CRITERIA

## GENERAL DESCRIPTION

### DF:DTC P1134 — A/F SENSOR MICRO-COMPUTER PROBLEM —

#### 1. OUTLINE OF DIAGNOSIS

Detect the malfunction of IC communication.

Judge NG when the IC communication malfunction occurs.

#### 2. COMPONENT DESCRIPTION

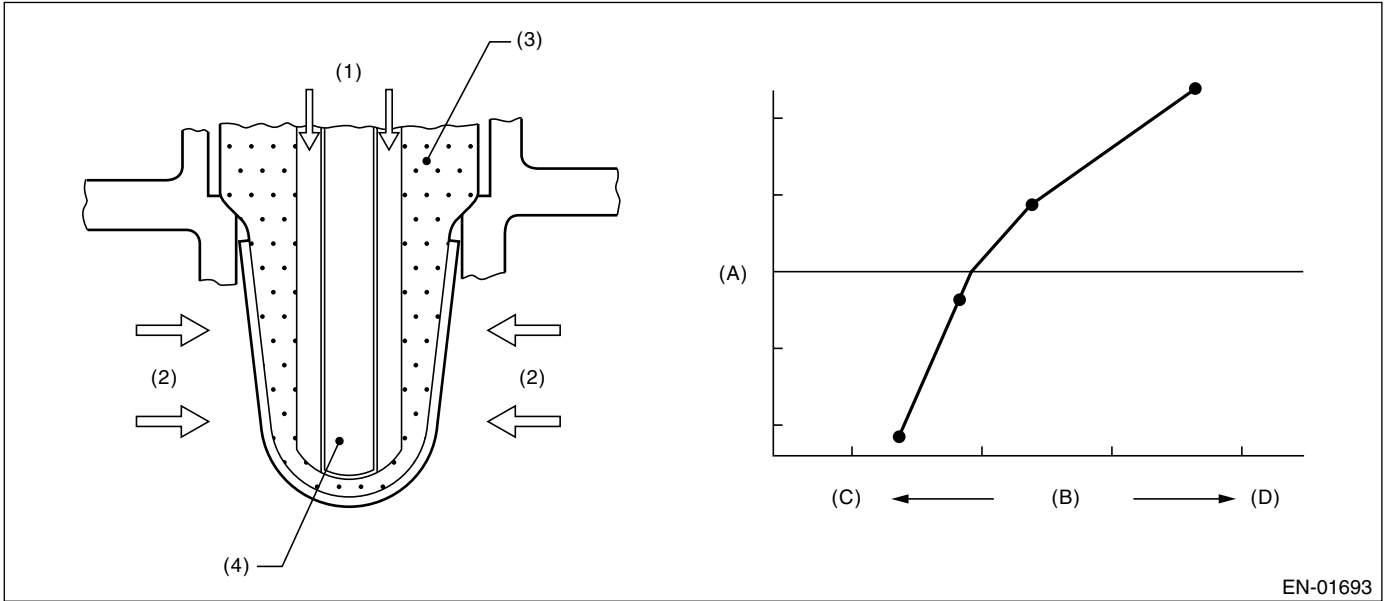

EN-01693

- |                      |                         |
|----------------------|-------------------------|
| (1) Atmosphere       | (A) Electromotive force |
| (2) Exhaust          | (B) Air fuel ratio      |
| (3) ZrO <sub>2</sub> | (C) Lean                |
| (4) Ceramic heater   | (D) Rich                |

#### 3. ENABLE CONDITION

Secondary Parameters	Enable Conditions
None	

#### 4. GENERAL DRIVING CYCLE

Always perform the diagnosis continuously.



# DIAGNOSTIC TROUBLE CODE (DTC) DETECTING CRITERIA

GENERAL DESCRIPTION

## 5. DIAGNOSTIC METHOD

### • Abnormality Judgment

Judge NG when the malfunction criteria below are completed.

### • Judgment Value

Malfunction Criteria	Threshold Value
Continuous 6 times communication error to main CPU	≥ 2 sets

**Time Needed for Diagnosis:** Not determined

**Malfunction Indicator Light Illumination:** Illuminates as soon as malfunction occurs.

### • Normality Judgment

Judge OK when the malfunction criteria below are completed.

### • Judgment Value

Malfunction Criteria	Threshold Value
Normal communication	2 times in a row

## 6. DTC CLEAR CONDITION

- When the OK idling cycle was completed 40 times in a row
- When "Clear Memory" was performed

## 7. MALFUNCTION INDICATOR LIGHT CLEAR CONDITION

- When the OK driving cycle was completed 3 times in a row
- When "Clear Memory" was performed

## 8. FAIL SAFE

- A/F IC communication: Not allowed to communicate.
- A/F main learning compensation: Not allowed to calculate.
- Compensation at high temperature restart: Set min. value 0.06 → 0.
- Purge control: Not allowed to purge.

## 9. ECM OPERATION AT DTC SETTING

Memorize the freeze frame data. (For test mode \$02)

# DIAGNOSTIC TROUBLE CODE (DTC) DETECTING CRITERIA

## GENERAL DESCRIPTION

### DG:DTC P1152 — O<sub>2</sub> SENSOR CIRCUIT RANGE/PERFORMANCE (LOW) (BANK 1 SENSOR 1) —

#### 1. OUTLINE OF DIAGNOSIS

Detect that lambda value remains Low.

Judge NG when lambda value is abnormal in accordance with lambda value of front oxygen (A/F) sensor and running condition that is vehicle speed, amount of intake air engine coolant temperature, sub feedback control, etc.

**Lambda value = Actual air fuel ratio/Theoretical air fuel ratio**

Lambda > 1: Lean

Lambda < 1: Rich

#### 2. COMPONENT DESCRIPTION

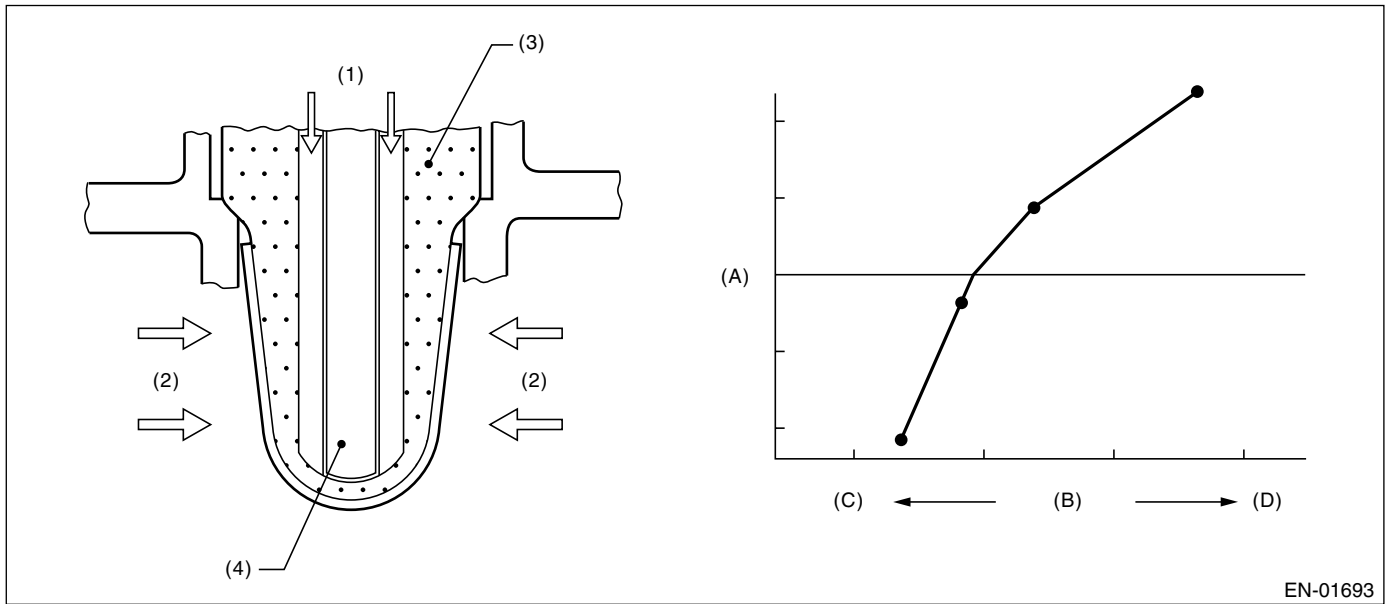

EN-01693

- (1) Atmosphere
- (2) Exhaust
- (3) ZrO<sub>2</sub>
- (4) Ceramic heater

- (A) Electromotive force
- (B) Air fuel ratio
- (C) Lean
- (D) Rich

# DIAGNOSTIC TROUBLE CODE (DTC) DETECTING CRITERIA

GENERAL DESCRIPTION

## 3. ENABLE CONDITION

Secondary Parameters	Enable Conditions
All secondary parameters to be in enable conditions	4 seconds or more
Battery voltage	> 10.9 V
Atmospheric pressure	> 75.1 kPa (563 mmHg, 22.2 inHg)
Rear oxygen sensor sub feedback	Operating
Rear oxygen sensor output voltage – feedback target voltage	–0.2 V ↔ 0.1 V
or rear oxygen sensor sub feedback compensation coefficient	On Min.
or rear oxygen sensor sub feedback compensation coefficient	On Max.
After engine starting	60 seconds or more
Engine coolant temperature	≥ 75°C (167°F)
Vehicle speed	≥ 20 km/h (12 MPH)
Amount of intake air	≥ 8 g (0.28 oz)/s
Change of manifold pressure every 0.5 engine revolutions	≤ 1.95 kPa (14.6 mmHg, 0.575 inHg)
Impedance of front oxygen (A/F) sensor	0 ↔ 52 Ω
Learning value of evaporation gas density	≤ 0.2
Total time of operating canister purge	20 seconds or more

## 4. GENERAL DRIVING CYCLE

Perform diagnosis continuously at a constant speed of 20 km/h (12 MPH) or more since 60 seconds after starting the engine.

## 5. DIAGNOSTIC METHOD

Judge NG when the continuous time of completing the malfunction criteria below becomes more than the time needed for diagnosis (10 seconds). Judge OK and clear NG when the malfunction criteria below are not completed.

### Judgment Value

Malfunction Criteria	Threshold Value
Output lambda when rear oxygen sensor sub feedback compensation coefficient being at not high limit	≤ 0.85

**Time Needed for Diagnosis:** 10 seconds

**Malfunction Indicator Light Illumination:** Illuminates when malfunction occurs in 2 continuous driving cycles.

## 6. DTC CLEAR CONDITION

- When the OK idling cycle was completed 40 times in a row
- When “Clear Memory” was performed

## 7. MALFUNCTION INDICATOR LIGHT CLEAR CONDITION

- When the OK driving cycle was completed 3 times in a row
- When “Clear Memory” was performed

# DIAGNOSTIC TROUBLE CODE (DTC) DETECTING CRITERIA

## GENERAL DESCRIPTION

---

### 8. FAIL SAFE

- Front oxygen (A/F) sensor main learning correction: Not allowed to calculate.
- Rear oxygen sensor sub learning correction: Not allowed to calculate.
- Correction when re-starting at high temperature: Normally minimum value 0.06 → 0
- Purge control: Not allowed to purge

### 9. ECM OPERATION AT DTC SETTING

Memorize the freeze frame data. (For test mode \$02)

# DIAGNOSTIC TROUBLE CODE (DTC) DETECTING CRITERIA

GENERAL DESCRIPTION

---

MEMO:

# DIAGNOSTIC TROUBLE CODE (DTC) DETECTING CRITERIA

## GENERAL DESCRIPTION

### DH:DTC P1153 — O<sub>2</sub> SENSOR CIRCUIT RANGE/PERFORMANCE (HIGH) (BANK 1 SENSOR 1) —

#### 1. OUTLINE OF DIAGNOSIS

Detect that lambda value remains High.

Judge NG when lambda value is abnormal in accordance with lambda value of front oxygen (A/F) sensor and running condition that is vehicle speed, amount of intake air engine coolant temperature, sub feedback control, etc.

**Lambda value = Actual air fuel ratio/Theoretical air fuel ratio**

Lambda > 1: Lean

Lambda < 1: Rich

#### 2. COMPONENT DESCRIPTION

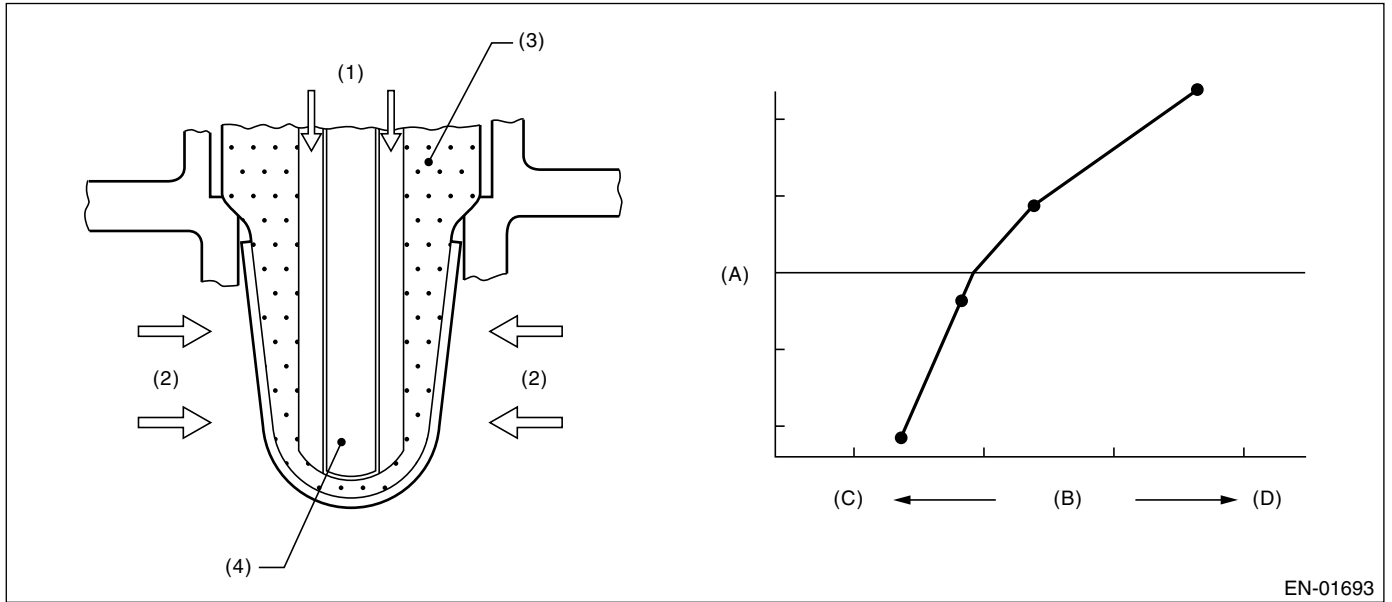

EN-01693

- (1) Atmosphere
- (2) Exhaust
- (3) ZrO<sub>2</sub>
- (4) Ceramic heater

- (A) Electromotive force
- (B) Air fuel ratio
- (C) Lean
- (D) Rich

# DIAGNOSTIC TROUBLE CODE (DTC) DETECTING CRITERIA

GENERAL DESCRIPTION

## 3. ENABLE CONDITION

Secondary Parameters	Enable Conditions
All secondary parameters to be in enable conditions	4 seconds or more
Battery voltage	> 10.9 V
Atmospheric pressure	> 75.1 kPa (563 mmHg, 22.2 inHg)
Rear oxygen sensor sub feedback	Operating
Rear oxygen sensor output voltage – feedback target voltage	–0.2 V ↔ 0.1 V
or rear oxygen sensor sub feedback compensation coefficient	On Min.
or rear oxygen sensor sub feedback compensation coefficient	On Max.
After engine starting	60 seconds or more
Engine coolant temperature	≥ 75°C (167°F)
Vehicle speed	≥ 20 km/h (12 MPH)
Amount of intake air	≥ 8 g (0.28 oz)/s
Change of manifold pressure every 0.5 engine revolutions	≤ 1.95 kPa (14.6 mmHg, 0.575 inHg)
Impedance of front oxygen (A/F) sensor	0 ↔ 52 Ω
Learning value of evaporation gas density	≤ 0.2
Total time of operating canister purge	20 seconds or more

## 4. GENERAL DRIVING CYCLE

Perform diagnosis continuously at a constant speed of 20 km/h (12 MPH) or more since 60 seconds after starting the engine.

## 5. DIAGNOSTIC METHOD

Judge NG when the continuous time of completing the malfunction criteria below becomes more than the time needed for diagnosis (10 seconds). Judge OK and clear NG when the malfunction criteria below are not completed.

### Judgment Value

Malfunction Criteria	Threshold Value
Output lambda when rear O <sub>2</sub> sensor sub feedback compensation coefficient value being at not low limit	≥ 1.15

**Time Needed for Diagnosis:** 10 seconds

**Malfunction Indicator Light Illumination:** Illuminates when malfunction occurs in 2 continuous driving cycles.

## 6. DTC CLEAR CONDITION

- When the OK idling cycle was completed 40 times in a row
- When “Clear Memory” was performed

## 7. MALFUNCTION INDICATOR LIGHT CLEAR CONDITION

- When the OK driving cycle was completed 3 times in a row
- When “Clear Memory” was performed

# DIAGNOSTIC TROUBLE CODE (DTC) DETECTING CRITERIA

## GENERAL DESCRIPTION

---

### 8. FAIL SAFE

- Front oxygen (A/F) sensor main learning correction: Not allowed to calculate.
- Rear oxygen sensor sub learning correction: Not allowed to calculate.
- Correction when re-starting at high temperature: Normally minimum value 0.06 → 0
- Purge control: Not allowed to purge

### 9. ECM OPERATION AT DTC SETTING

Memorize the freeze frame data. (For test mode \$02)



## DIAGNOSTIC TROUBLE CODE (DTC) DETECTING CRITERIA

GENERAL DESCRIPTION

---

### **DI: DTC P1154 — O2 SENSOR CIRCUIT RANGE/PERFORMANCE (LOW) (BANK 2 SENSOR 1) —**

**NOTE:**

For the detecting condition, refer to DTC P1152. <Ref. to GD(H6DO)-218, DTC P1152 — O2 SENSOR CIRCUIT RANGE/PERFORMANCE (LOW) (BANK 1 SENSOR 1) —, Diagnostic Trouble Code (DTC) Detecting Criteria.>

### **DJ:DTC P1155 — O2 SENSOR CIRCUIT RANGE/PERFORMANCE (HIGH) (BANK 2 SENSOR 1) —**

**NOTE:**

For the detecting condition, refer to DTC P1153. <Ref. to GD(H6DO)-222, DTC P1153 — O2 SENSOR CIRCUIT RANGE/PERFORMANCE (HIGH) (BANK 1 SENSOR 1) —, Diagnostic Trouble Code (DTC) Detecting Criteria.>

# DIAGNOSTIC TROUBLE CODE (DTC) DETECTING CRITERIA

## GENERAL DESCRIPTION

### DK:DTC P1400 — FUEL TANK PRESSURE CONTROL SOLENOID VALVE CIRCUIT LOW —

#### 1. OUTLINE OF DIAGNOSIS

Detect open or short circuit of pressure control solenoid valve. Judge NG when ECM output level is different from actual terminal level.

#### 2. COMPONENT DESCRIPTION

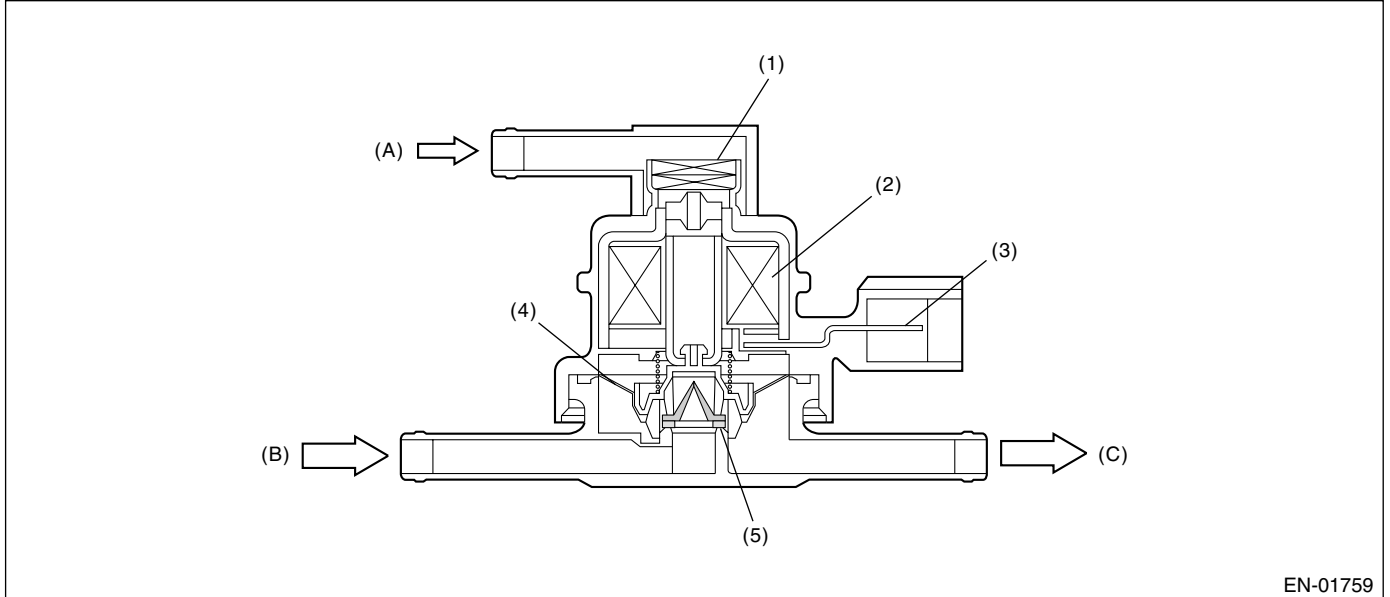

- |                        |               |                          |
|------------------------|---------------|--------------------------|
| (1) Filter             | (4) Diaphragm | (A) Atmospheric pressure |
| (2) Coil               | (5) Valve     | (B) Shut off valve       |
| (3) Connector terminal |               | (C) To fuel tank         |

#### 3. ENABLE CONDITION

Secondary Parameters	Enable Conditions
Ignition switch	ON
Battery voltage	$\geq 10.9 \text{ V}$
After engine starting	1 second or more

#### 4. GENERAL DRIVING CYCLE

Always perform the diagnosis after starting the engine.

#### 5. DIAGNOSTIC METHOD

Judge NG when the continuous time of completing the malfunction criteria below becomes more than time needed for diagnosis (2.5 seconds). Judge OK and clear the NG when the malfunction criteria below are not completed.

##### Judgment Value

Malfunction Criteria	Threshold Value
Terminal voltage when ECM outputs off signal	Low

**Time Needed for Diagnosis:** 2.5 seconds

**Malfunction Indicator Light Illumination:** Illuminates when malfunction occurs in two continuous drive cycles.

# DIAGNOSTIC TROUBLE CODE (DTC) DETECTING CRITERIA

GENERAL DESCRIPTION

---

## 6. DTC CLEAR CONDITION

- When the OK idling cycle was completed 40 times in a row
- When "Clear Memory" was performed

## 7. MALFUNCTION INDICATOR LIGHT CLEAR CONDITION

- When the OK driving cycle was completed 3 times in a row
- When "Clear Memory" was performed

## 8. FAIL SAFE

None

## 9. ECM OPERATING AT DTC SETTING

Memorize the freeze frame data. (For test mode \$02)

# DIAGNOSTIC TROUBLE CODE (DTC) DETECTING CRITERIA

## GENERAL DESCRIPTION

### DL:DTC P1420 — FUEL TANK PRESSURE CONTROL SOL. VALVE CIRCUIT HIGH —

#### 1. OUTLINE OF DIAGNOSIS

Detect open or short circuit of pressure control solenoid valve.  
Judge NG when ECM output level is different from actual terminal level.

#### 2. COMPONENT DESCRIPTION

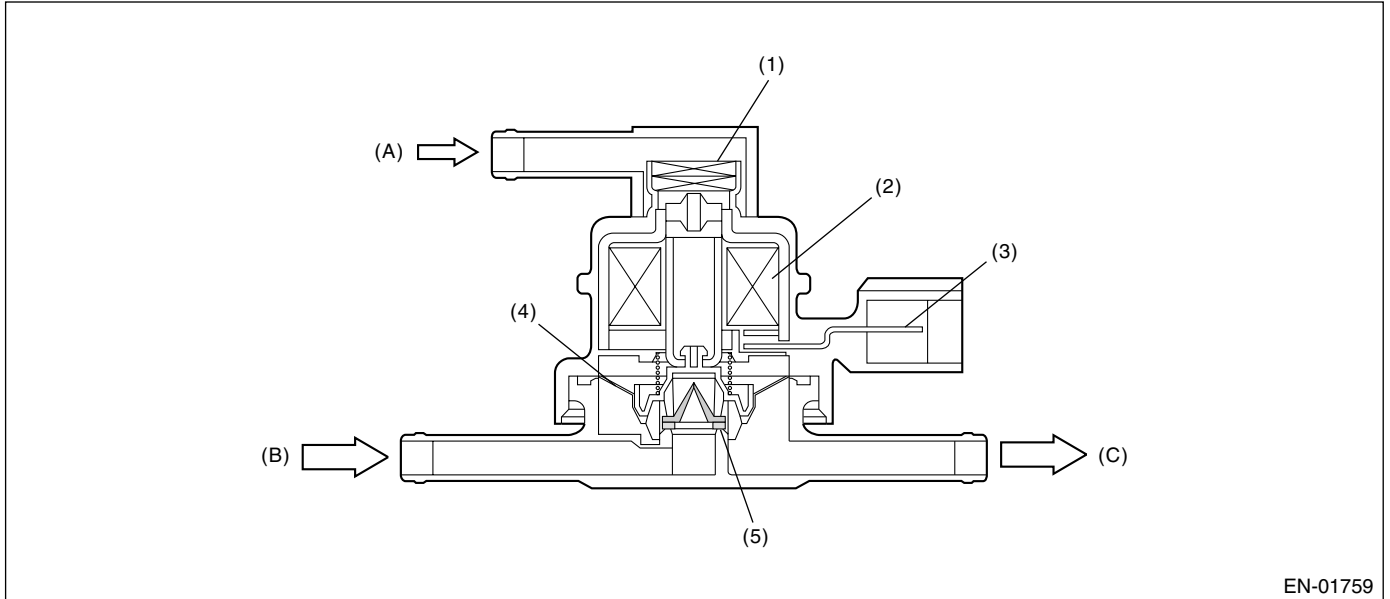

- |                        |               |                          |
|------------------------|---------------|--------------------------|
| (1) Filter             | (4) Diaphragm | (A) Atmospheric pressure |
| (2) Coil               | (5) Valve     | (B) Shut off valve       |
| (3) Connector terminal |               | (C) To fuel tank         |

#### 3. ENABLE CONDITION

Secondary Parameters	Enable Conditions
Ignition switch	ON
Battery voltage	$\geq 10.9 \text{ V}$
After engine starting	1 second or more

#### 4. GENERAL DRIVING CYCLE

Always perform the diagnosis after starting the engine.

#### 5. DIAGNOSTIC METHOD

Judge NG when the continuous time of completing the malfunction criteria below becomes more than time needed for diagnosis (2.5 seconds). Judge OK and clear the NG when the malfunction criteria below are not completed.

##### Judgment Value

Malfunction Criteria	Threshold Value
Terminal voltage when ECM outputs off signal	High

**Time Needed for Diagnosis:** 2.5 seconds

**Malfunction Indicator Light Illumination:** Illuminates when malfunction occurs in two continuous drive cycles.

# DIAGNOSTIC TROUBLE CODE (DTC) DETECTING CRITERIA

GENERAL DESCRIPTION

---

## 6. DTC CLEAR CONDITION

- When the OK idling cycle was completed 40 times in a row
- When "Clear Memory" was performed

## 7. MALFUNCTION INDICATOR LIGHT CLEAR CONDITION

- When the OK driving cycle was completed 3 times in a row
- When "Clear Memory" was performed

## 8. FAIL SAFE

None

## 9. ECM OPERATING AT DTC SETTING

Memorize the freeze frame data. (For test mode \$02)

# DIAGNOSTIC TROUBLE CODE (DTC) DETECTING CRITERIA

## GENERAL DESCRIPTION

### DM:DTC P1443 — VENT CONTROL SOLENOID VALVE FUNCTION PROBLEM —

#### 1. OUTLINE OF DIAGNOSIS

Detect malfunction of drain valve (open fixing).

Judge NG when the fuel tank pressure becomes smaller.

#### 2. COMPONENT DESCRIPTION

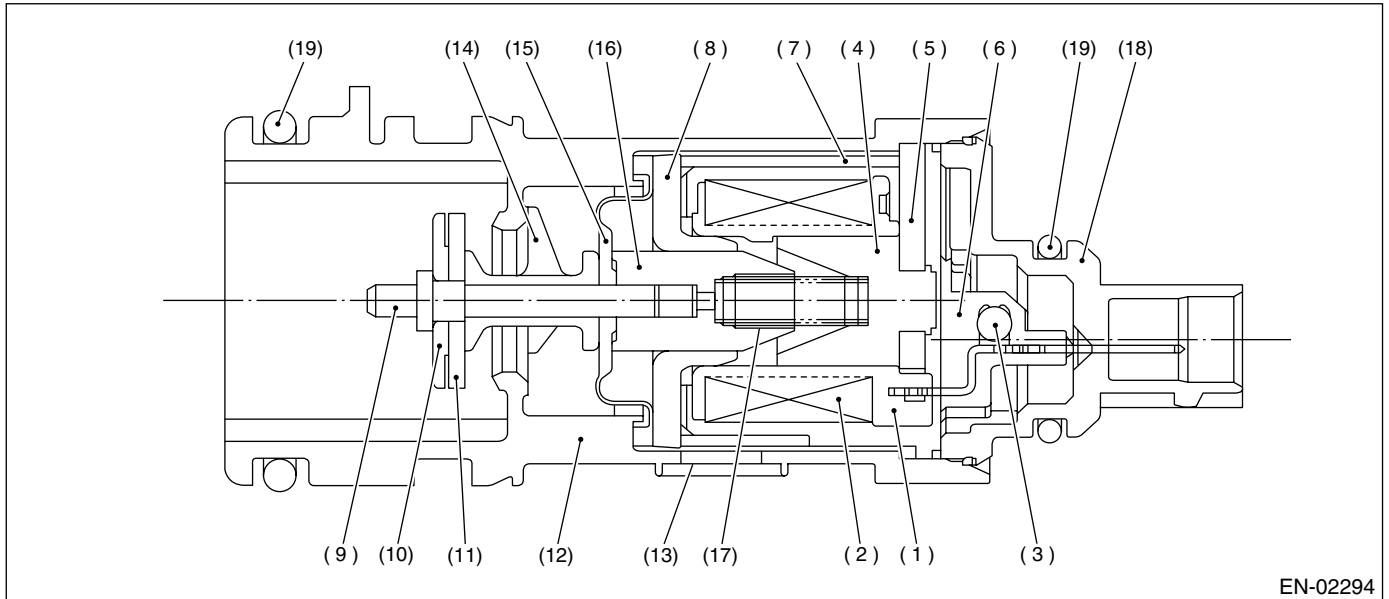

- |                 |                    |                   |
|-----------------|--------------------|-------------------|
| (1) Bobbin      | (8) Magnetic plate | (15) Diaphragm    |
| (2) Coil        | (9) Shaft          | (16) Movable core |
| (3) Diode       | (10) Plate         | (17) Spring       |
| (4) Stator core | (11) Valve         | (18) Cover        |
| (5) End plate   | (12) Housing       | (19) O-ring       |
| (6) Body        | (13) Fitter        |                   |
| (7) Yoke        | (14) Retainer      |                   |

#### 3. ENABLE CONDITION

Secondary Parameters	Enable Conditions
Battery voltage	$\geq 10.9 \text{ V}$
Atmospheric pressure	$\geq 75.0 \text{ kPa}$ (563 mmHg, 22.17 inHg)
Tank pressure when starter SW OFF → ON	$-5 \leftrightarrow 1.6 \text{ kPa}$ (2 mmHg, 0.47 inHg)
Drain valve	Open

#### 4. GENERAL DRIVING CYCLE

Always perform the diagnosis continuously.

# DIAGNOSTIC TROUBLE CODE (DTC) DETECTING CRITERIA

GENERAL DESCRIPTION

## 5. DIAGNOSTIC METHOD

### • Abnormality Judgment

Judge NG when the continuous time of completing the malfunction criteria below becomes more than 3 seconds.

### • Judgment Value

Malfunction Criteria	Threshold Value
Tank pressure	$\leq -4.0$ kPa ( $-30$ mmHg, $-1.18$ inHg)

**Time Needed for Diagnosis:** 3 seconds

**Malfunction Indicator Light Illumination:** Illuminates as soon as the malfunction occurs.

### • Normality Judgment

Judge OK and clear the NG when the malfunction criteria below are completed.

### • Judgment Value

Malfunction Criteria	Threshold Value
Tank pressure	$> -4.0$ kPa ( $-30$ mmHg, $-1.18$ inHg)
Cumulative time for completing the malfunction criteria below	$\geq 30$ seconds
Purge control solenoid valve duty ratio	Except 0
Fuel temperature	$-10 \leftrightarrow 45^\circ\text{C}$ ( $14 \leftrightarrow 133^\circ\text{F}$ )
Intake manifold relative pressure	$\leq -26.7$ kPa ( $-200$ mmHg, $-7.87$ inHg)

## 6. DTC CLEAR CONDITION

- When the OK idling cycle was completed 40 times in a row
- When "Clear Memory" was performed

## 7. MALFUNCTION INDICATOR LIGHT CLEAR CONDITION

- When the OK driving cycle was completed 3 times in a row
- When "Clear Memory" was performed

## 8. FAIL SAFE

PCV control: Open the PCV solenoid.

## 9. ECM OPERATION AT DTC SETTING

Memorize the freeze frame data. (For test mode \$02)

# DIAGNOSTIC TROUBLE CODE (DTC) DETECTING CRITERIA

## GENERAL DESCRIPTION

### DN:DTC P1446 — FUEL TANK SENSOR CONTROL VALVE CIRCUIT LOW —

#### 1. OUTLINE OF DIAGNOSIS

Detect the open or short circuit of tank pressure switching solenoid.

Judge NG when the ECM output level is different from actual terminal level.

#### 2. COMPONENT DESCRIPTION

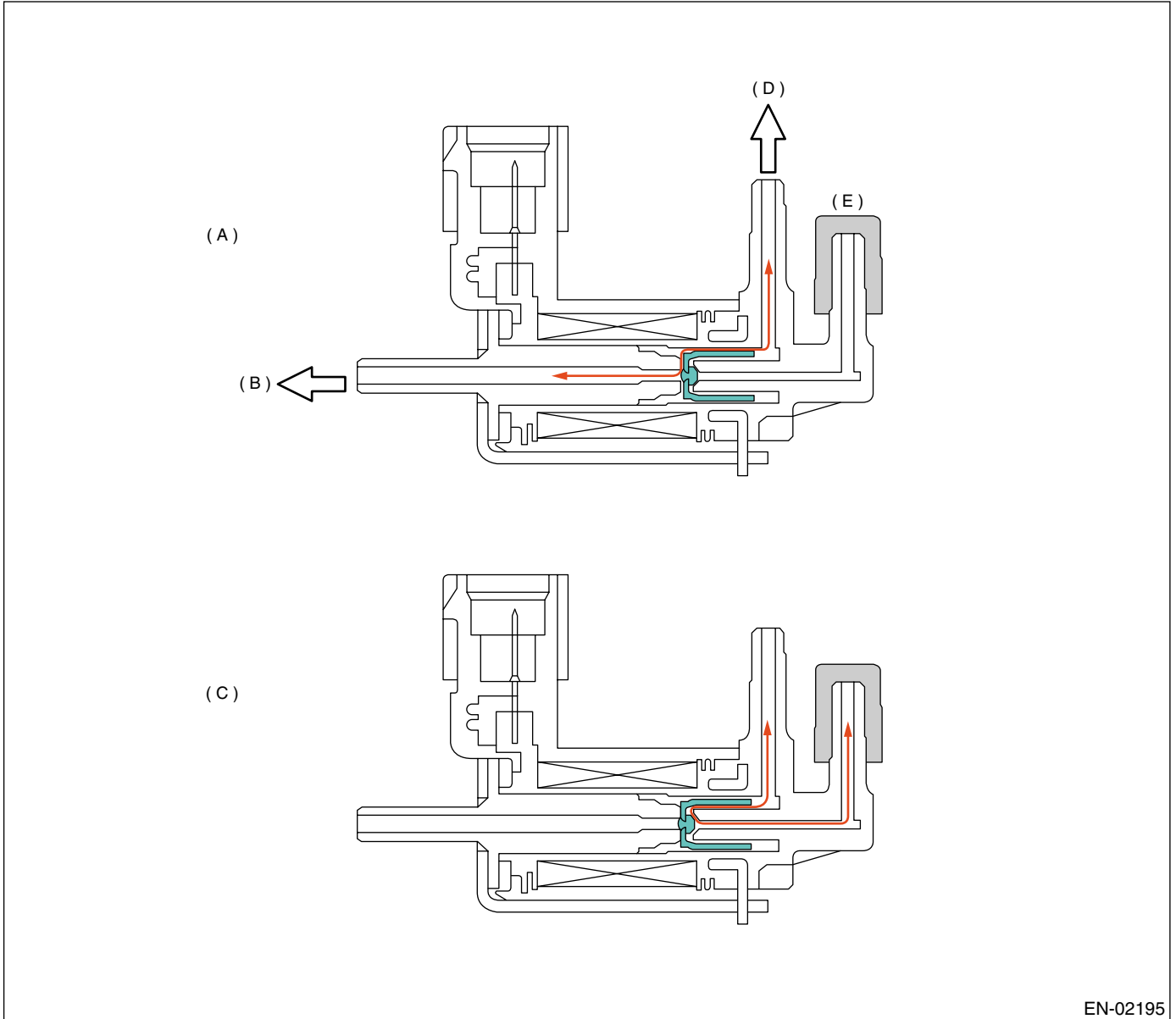

#### 3. ENABLE CONDITION

Secondary Parameters	Enable Conditions
None	

#### 4. GENERAL DRIVING CYCLE

Always perform the diagnosis continuously.



# DIAGNOSTIC TROUBLE CODE (DTC) DETECTING CRITERIA

GENERAL DESCRIPTION

## 5. DIAGNOSTIC METHOD

### • Abnormality Judgment

Judge NG when the continuous time of completing the malfunction criteria below becomes more than 2.5 seconds.

### • Judgment Value

Malfunction Criteria	Threshold Value
Battery voltage	$\geq 10.9$ V
Ignition switch	ON
After engine starting	1 second or more
Terminal output voltage when ECM sent OFF signals	Low

**Time Needed for Diagnosis:** 2.5 seconds

**Malfunction Indicator Light Illumination:** Illuminates when malfunction occurs in 2 continuous driving cycles.

### • Normality Judgment

Judge OK when the malfunction criteria below are completed.

### • Judgment Value

Malfunction Criteria	Threshold Value
Battery voltage	$\geq 10.9$ V
After engine starting	1 second or more
Terminal output voltage when ECM sent OFF signals	High

## 6. DTC CLEAR CONDITION

- When the OK idling cycle is completed 40 times in a row
- When "Clear Memory" was performed

## 7. MALFUNCTION INDICATOR LIGHT CLEAR CONDITION

- When the OK driving cycle is completed 3 times in a row
- When "Clear Memory" was performed

## 8. FAIL SAFE

None

## 9. ECM OPERATION AT DTC SETTING

Memorize the freeze frame data. (For test mode \$02)

# DIAGNOSTIC TROUBLE CODE (DTC) DETECTING CRITERIA

## GENERAL DESCRIPTION

### DO:DTC P1447 — FUEL TANK SENSOR CONTROL VALVE CIRCUIT HIGH —

#### 1. OUTLINE OF DIAGNOSIS

Detect the open or short circuit of tank pressure switching solenoid.

Judge NG when the ECM output level is different from actual terminal level.

#### 2. COMPONENT DESCRIPTION

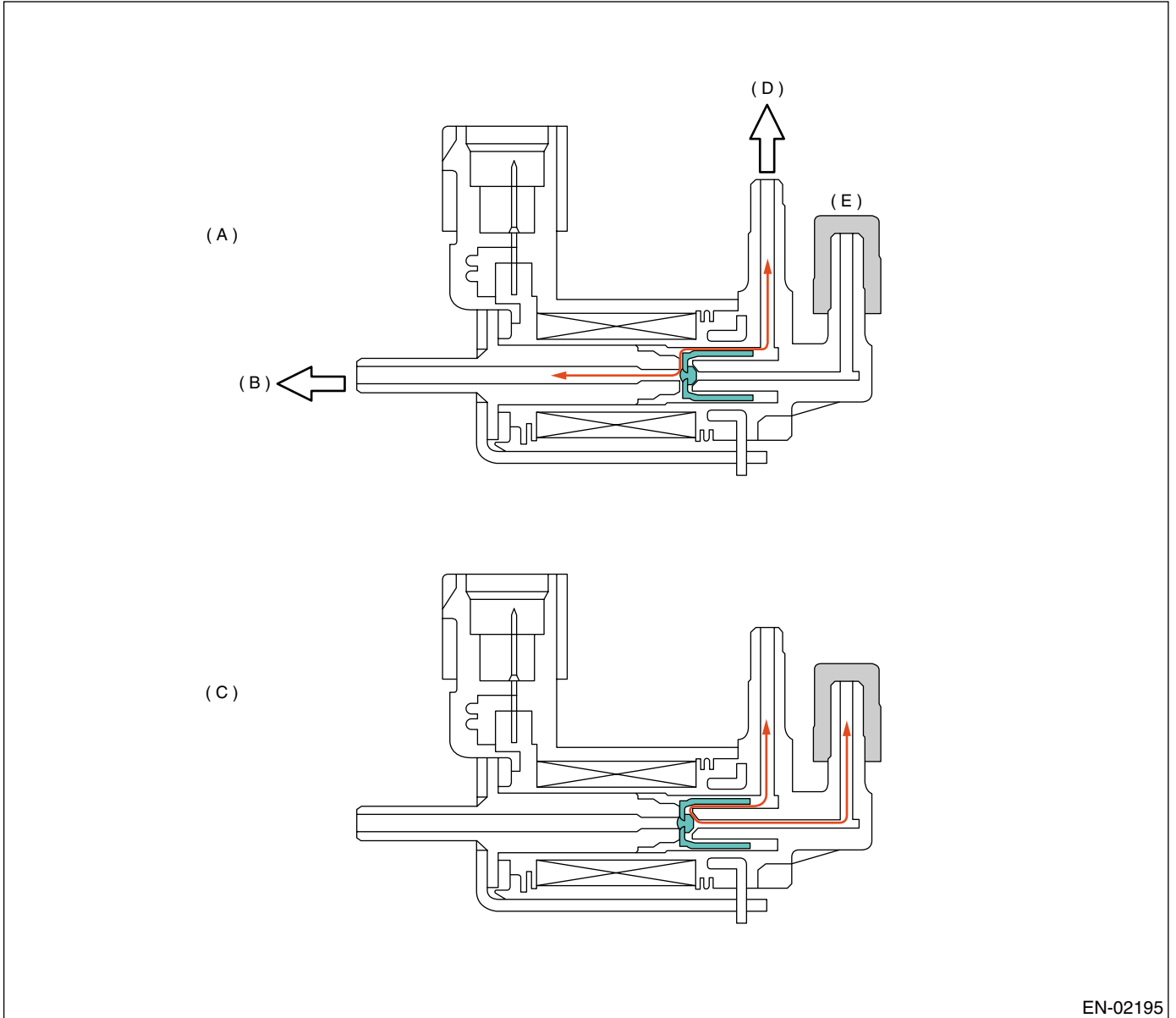

(A) Open atmosphere (solenoid OFF)  
(B) Ambient air

(C) During trouble diagnosis (solenoid ON)

(D) To pressure sensor  
(E) Plug

#### 3. ENABLE CONDITION

Secondary Parameters	Enable Conditions
None	

#### 4. GENERAL DRIVING CYCLE

Always perform the diagnosis continuously.

# DIAGNOSTIC TROUBLE CODE (DTC) DETECTING CRITERIA

GENERAL DESCRIPTION

## 5. DIAGNOSTIC METHOD

### • Abnormality Judgment

Judge NG when the cumulative time of completing the malfunction criteria below becomes more than 2.5 seconds.

### • Judgment Value

Malfunction Criteria	Threshold Value
Battery voltage	$\geq 10.9$ V
Ignition switch	ON
After engine starting	1 second or more
Terminal output voltage when ECM sent ON signals	High

**Time Needed for Diagnosis:** 2.5 seconds

**Malfunction Indicator Light Illumination:** Illuminates when malfunction occurs in two continuous drive cycles.

### • Normality Judgment

Judge OK when the malfunction criteria below are completed.

### • Judgment Value

Malfunction Criteria	Threshold Value
Battery voltage	$\geq 10.9$ V
After engine starting	1 second or more
Terminal output voltage when ECM sent OFF signals	Low

## 6. DTC CLEAR CONDITION

- When the OK idling cycle is completed 40 times in a row
- When "Clear Memory" was performed

## 7. MALFUNCTION INDICATOR LIGHT CLEAR CONDITION

- When the OK driving cycle is completed 3 times in a row
- When "Clear Memory" was performed

## 8. FAIL SAFE

None

## 9. ECM OPERATION AT DTC SETTING

Memorize the freeze frame data. (For test mode \$02)

# DIAGNOSTIC TROUBLE CODE (DTC) DETECTING CRITERIA

## GENERAL DESCRIPTION

### DP:DTC P1448 — FUEL TANK SENSOR CONTROL VALVE RANGE PERFORMANCE —

#### 1. OUTLINE OF DIAGNOSIS

Detect the tank pressure switching solenoid function abnormality.

The tank pressure sensor is a relative pressure sensor, which normally compares the pressure with the atmospheric pressure. The tank pressure switching solenoid is a solenoid, which shifts the compare space from opening to closed during the EVAP diagnosis. Detect the malfunction that the compare space remains closed. (Not judge NG after enable condition completed but assume NG before enable condition completed.)

#### • Normality Judgment

Judge OK when the fuel tank pressure does not change (or changes by less than 0.60 kPa (4.5 mmHg, 0.18 inHg) at atmospheric pressure changing by 0.60 kPa (4.5 mmHg, 0.18 inHg) or more per 80 seconds.

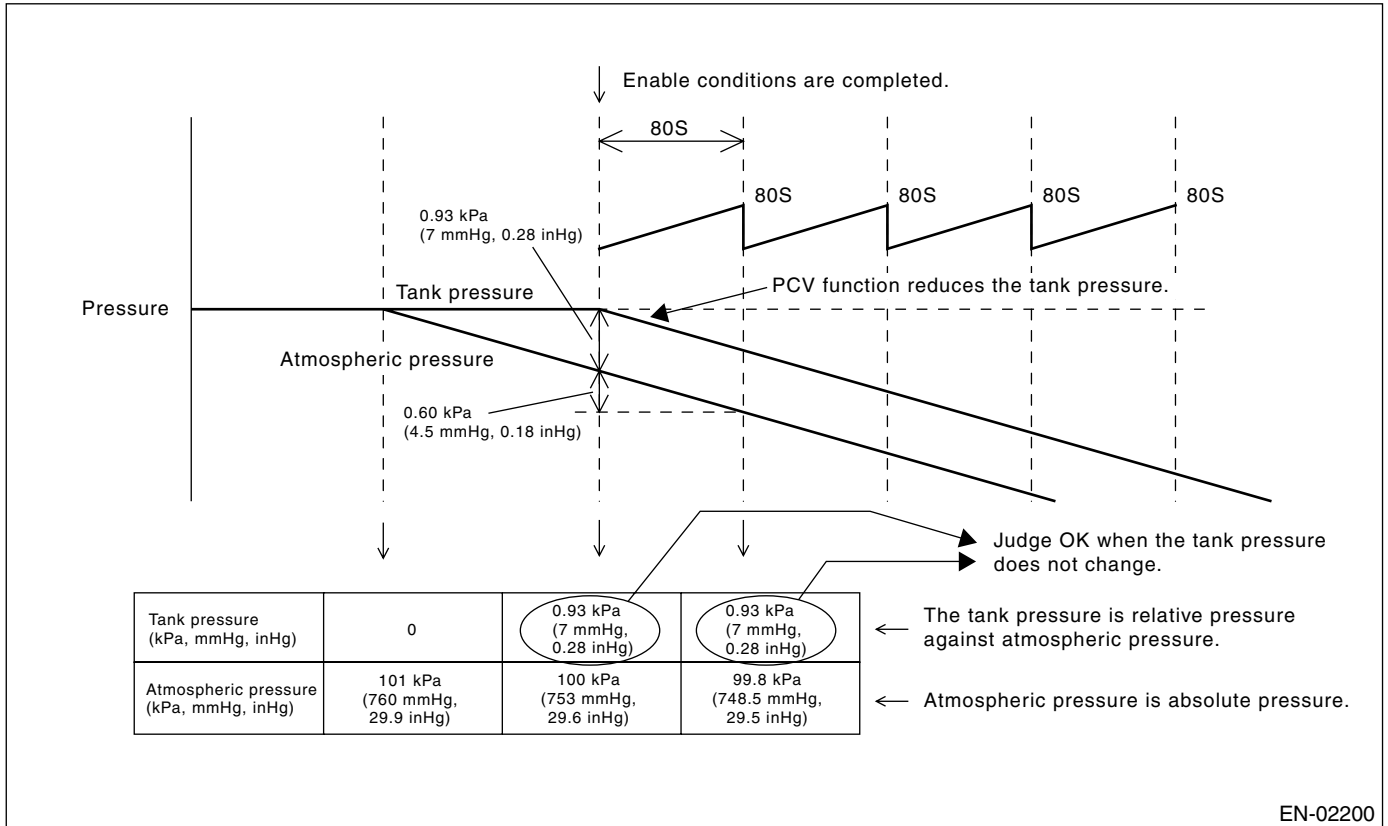

# DIAGNOSTIC TROUBLE CODE (DTC) DETECTING CRITERIA

GENERAL DESCRIPTION

## • Abnormality Judgment

Judge NG temporarily when the fuel tank pressure changes by 0.60 kPa (4.5 mmHg, 0.18 inHg) or more at atmospheric pressure changing by 0.60 kPa (4.5 mmHg, 0.18 inHg) or more per 80 seconds, and then judge NG when the previous condition is completed 5 times in a row.

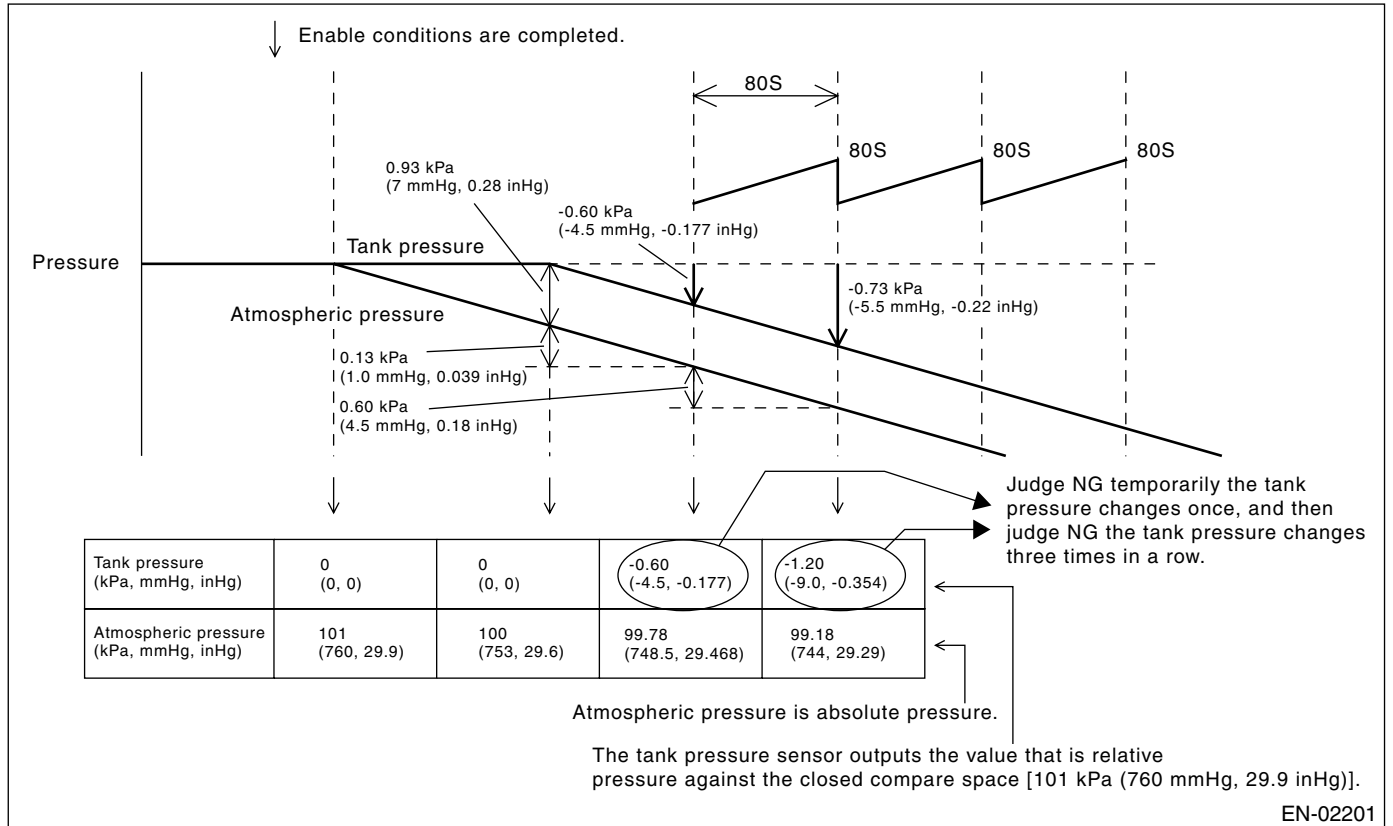

# DIAGNOSTIC TROUBLE CODE (DTC) DETECTING CRITERIA

## GENERAL DESCRIPTION

### 2. COMPONENT DESCRIPTION

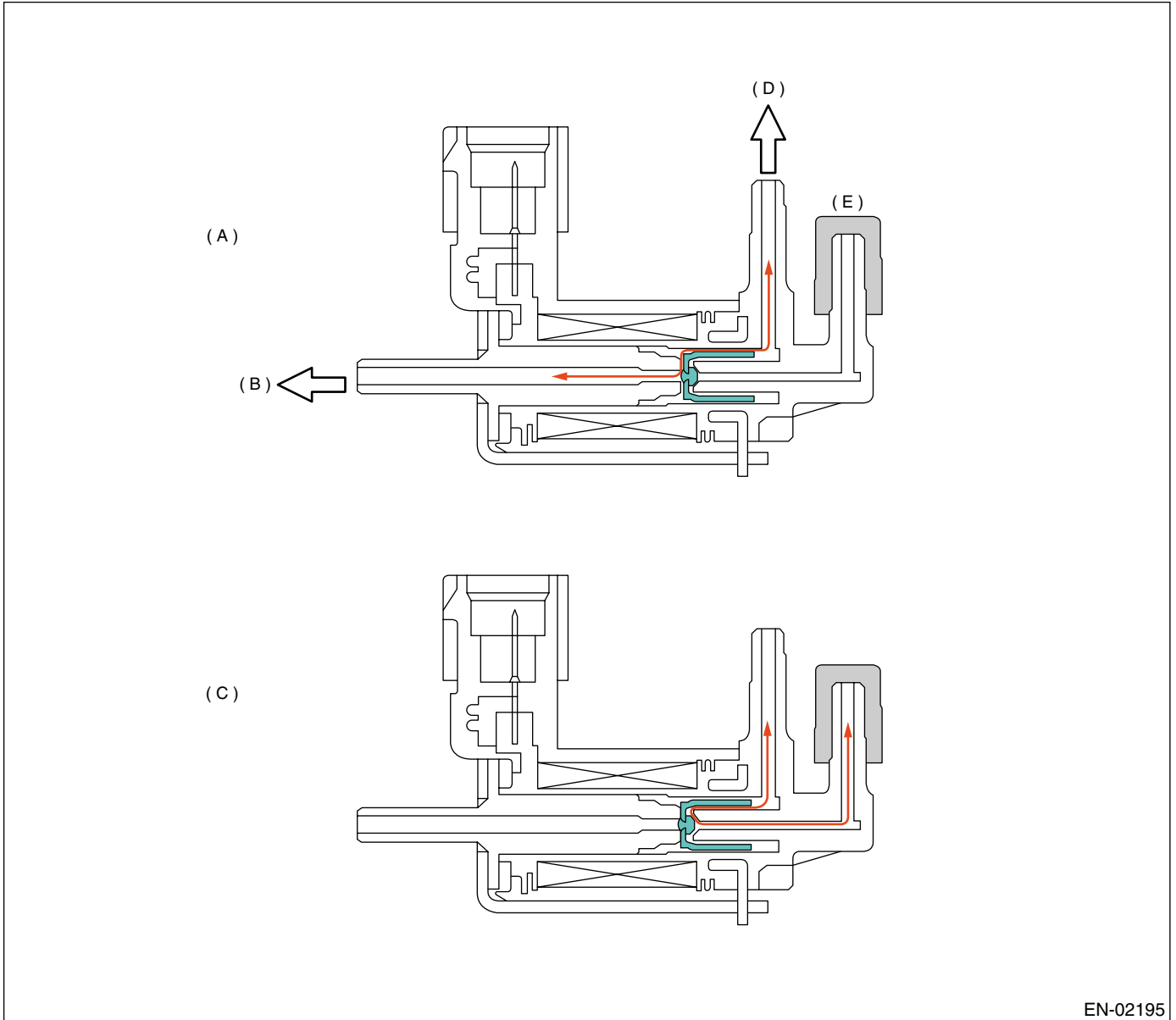

EN-02195

- (A) Open atmosphere (solenoid OFF)      (C) During trouble diagnosis (solenoid ON)      (D) To pressure sensor  
 (B) Ambient air      (E) Plug

### 3. ENABLE CONDITION

Secondary Parameter	Enable Condition
Battery voltage	$\geq 10.9 \text{ V}$
Fuel level	$9.6 \leftrightarrow 48 \text{ l}$ (2.54 $\leftrightarrow 12.68 \text{ US gal}$ , $2.11 \leftrightarrow 10.56 \text{ Imp gal}$ )
Evaporation system diagnosis	Not in operation
After starting the engine	80 seconds or more
Fuel tank pressure	$< 0.1 \text{ kPa}$ (1 mmHg, $0.04 \text{ inHg}$ ) or $> -0.93 \text{ kPa}$ (7 mmHg, 0.28 inHg)

# DIAGNOSTIC TROUBLE CODE (DTC) DETECTING CRITERIA

GENERAL DESCRIPTION

## 4. GENERAL DRIVING CYCLE

Perform the diagnosis continuously when the fuel tank pressure is large or small in 80 seconds or more after starting the engine.

## 5. DIAGNOSTIC METHOD

### • Abnormality Judgment

Judge NG when the malfunction criteria below is completed 5 times.

### • Judgment Value

Malfunction Criteria	Threshold Value
Atmospheric air change in 80 seconds	$\geq 0.60$ kPa (4.5 mmHg, 0.18 inHg)
Fuel tank pressure change in 80 seconds	$\geq 0.60$ kPa (4.5 mmHg, 0.18 inHg)
Fuel level change	$< 3 \ell$ (0.8 US gal, 0.7 Imp gal)

**Time Needed for Diagnosis:** 80 seconds  $\times$  5 times

**Malfunction Indicator Light Illumination:** Illuminates when malfunction occurs in 2 continuous driving cycles.

### • Normality Judgment

Judge OK and clear NG when the malfunction criteria below is completed.

### • Judgment Value

Malfunction Criteria	Threshold Value
Atmospheric air change in 80 seconds	$\geq 0.60$ kPa (4.5 mmHg, 0.18 inHg)
Fuel tank pressure change in 80 seconds	$< 0.60$ kPa (4.5 mmHg, 0.18 inHg)

## 6. DTC CLEAR CONDITION

- When the OK idling cycle was completed 40 times in a row
- When "Clear Memory" was performed

## 7. MALFUNCTION INDICATOR LIGHT CLEAR CONDITION

- When the OK driving cycle was completed 3 times in a row
- When "Clear Memory" was performed

## 8. FAIL SAFE

None

## 9. ECM OPERATION AT DTC SETTING

Memorize the freeze frame data. (For test mode \$02)

# DIAGNOSTIC TROUBLE CODE (DTC) DETECTING CRITERIA

## GENERAL DESCRIPTION

### DQ:DTC P1518 — STARTER SWITCH CIRCUIT LOW INPUT —

#### 1. OUTLINE OF DIAGNOSIS

Detect the open or short circuit of starter SW.

Judge OFF NG when the engine starts without starter ON experience.

#### 2. ENABLE CONDITION

Secondary Parameters	Enable Conditions
None	

#### 3. GENERAL DRIVING CYCLE

Always perform the diagnosis continuously.

#### 4. DIAGNOSTIC METHOD

##### • Abnormality Judgment

Judge OFF NG when the malfunction criteria below are completed.

##### • Judgment Value

Malfunction Criteria	Threshold Value
Vehicle speed	< 1 km/h (0.62 MPH)
Starter ON signal	Not detected
Engine speed after 0.8 second continuity.	< 500 rpm
Engine speed	≥ 500 rpm

**Time Needed for Diagnosis:** 1 second

**Malfunction Indicator Light Illumination:** Illuminates when malfunction occurs in 2 continuous driving cycles.

##### • Normality Judgment

Judge OFF OK and clear the NG when the malfunction criteria below are completed.

##### • Judgment Value

Malfunction Criteria	Threshold Value
Starter ON	Experienced
Starter ON diagnosis	Diagnosed
Battery voltage	> 8 V

#### 5. DTC CLEAR CONDITION

- When the OK idling cycle was completed 40 times in a row
- When "Clear Memory" was performed

#### 6. MALFUNCTION INDICATOR LIGHT CLEAR CONDITION

- When the OK driving cycle was completed 3 times in a row
- When "Clear Memory" was performed

#### 7. FAIL SAFE

None

#### 8. ECM OPERATION AT DTC SETTING

Memorize the freeze frame data. (For test mode \$02)



# DIAGNOSTIC TROUBLE CODE (DTC) DETECTING CRITERIA

GENERAL DESCRIPTION

## DR:DTC P1560 — BACK-UP VOLTAGE CIRCUIT MALFUNCTION —

### 1. OUTLINE OF DIAGNOSIS

Detect open or short circuit of the back-up voltage circuit.  
Judge NG when the voltage of back-up power becomes small.

### 2. ENABLE CONDITION

Secondary Parameter	Enable Condition
None	

### 3. GENERAL DRIVING CYCLE

Always perform the diagnosis continuously.

### 4. DIAGNOSTIC METHOD

#### • Abnormality Judgment

Judge NG when the continuous time of completing the malfunction criteria below becomes more than 2.5 seconds.

#### • Judgment Value

Malfunction Criteria	Threshold Value
Voltage of back-up power	$< \text{Battery voltage} \times 0.7$
Battery voltage	$\geq 10.9 \text{ V}$

**Time Needed for Diagnosis:** 2.5 seconds

**Malfunction Indicator Light Illumination:** Illuminates as soon as malfunction occurs.

#### • Normality Judgment

Judge OK and clear NG when the malfunction criteria below is completed.

#### • Judgment Value

Malfunction Criteria	Threshold Value
Voltage of back-up power supply	$\geq \text{Battery voltage} \times 0.7$
Battery voltage	$\geq 10.9 \text{ V}$

### 5. DTC CLEAR CONDITION

- When the OK idling cycle was completed 40 times in a row
- When "Clear Memory" was performed

### 6. MALFUNCTION INDICATOR LIGHT CLEAR CONDITION

- When the OK driving cycle was completed 3 times in a row
- When "Clear Memory" was performed

### 7. FAIL SAFE

None

### 8. ECM OPERATION AT DTC SETTING

Memorize the freeze frame data. (For test mode \$02)

# DIAGNOSTIC TROUBLE CODE (DTC) DETECTING CRITERIA

## GENERAL DESCRIPTION

### DS:DTC P1698 — ENGINE TORQUE CONTROL CUT SIGNAL CIRCUIT MALFUNCTION (LOW INPUT) —

#### 1. OUTLINE OF DIAGNOSIS

Judge NG when the ECM output level is different from the actual terminal level.

#### 2. ENABLE CONDITION

Secondary Parameter	Enable Condition
None	

#### 3. GENERAL DRIVING CYCLE

Always perform the diagnosis continuously.

#### 4. DIAGNOSTIC METHOD

##### • Abnormality Judgment

Judge NG when the cumulative time of completing the malfunction criteria below becomes more than 2.5 seconds.

##### • Judgment Value

Malfunction Criteria	Threshold Value
Terminal voltage when ECM output is high (Timing of High → Low)	Low
Battery voltage	≥ 10.9 V
Engine speed	≥ 500 rpm
After engine starting	1 second or more

**Time Needed for Diagnosis:** 2.5 seconds

**Malfunction Indicator Light Illumination:** Illuminates when malfunction occurs in two continuous drive cycles.

##### • Normality Judgment

Judge OK and clear NG when the malfunction criteria below is completed.

##### • Judgment Value

Malfunction Criteria	Threshold Value
Terminal voltage when ECM output is high (Timing of High → Low)	High
Battery voltage	≥ 10.9 V
Engine speed	≥ 500 rpm
After engine starting	1 second or more

#### 5. DTC CLEAR CONDITION

- When the OK idling cycle was completed 40 times in a row
- When “Clear Memory” was performed

#### 6. MALFUNCTION INDICATOR LIGHT CLEAR CONDITION

- When the OK driving cycle was completed 3 times in a row
- When “Clear Memory” was performed

#### 7. FAIL SAFE

AT torque down control is not allowed.

#### 8. ECM OPERATION AT DTC SETTING

Memorize the freeze frame data. (For test mode \$02)

# DIAGNOSTIC TROUBLE CODE (DTC) DETECTING CRITERIA

GENERAL DESCRIPTION

## DT:DTC P1699 — ENGINE TORQUE CONTROL CUT SIGNAL CIRCUIT MALFUNCTION (HIGH INPUT) —

### 1. OUTLINE OF DIAGNOSIS

Judge NG when the ECM output level is different from the actual terminal level.

### 2. ENABLE CONDITION

Secondary Parameter	Enable Condition
None	

### 3. GENERAL DRIVING CYCLE

Always perform the diagnosis continuously.

### 4. DIAGNOSTIC METHOD

#### • Abnormality Judgment

Judge NG when the cumulative time of completing the malfunction criteria below becomes more than 2.5 seconds.

#### • Judgment Value

Malfunction Criteria	Threshold Value
Terminal voltage when ECM output is high (Timing of Low → High)	High
Battery voltage	≥ 10.9 V
Engine speed	≥ 500 rpm
After engine starting	1 second or more

**Time Needed for Diagnosis:** 2.5 seconds

**Malfunction Indicator Light Illumination:** Illuminates when malfunction occurs in two continuous drive cycles.

#### • Normality Judgment

Judge OK and clear NG when the malfunction criteria below is completed.

#### • Judgment Value

Malfunction Criteria	Threshold Value
Terminal voltage when ECM output is high (Timing of Low → High)	Low
Battery voltage	≥ 10.9 V
Engine speed	≥ 500 rpm
After engine starting	1 second or more

### 5. DTC CLEAR CONDITION

- When the OK idling cycle was completed 40 times in a row
- When “Clear Memory” was performed

### 6. MALFUNCTION INDICATOR LIGHT CLEAR CONDITION

- When the OK driving cycle was completed 3 times in a row
- When “Clear Memory” was performed

### 7. FAIL SAFE

AT torque down control is not allowed.

### 8. ECM OPERATION AT DTC SETTING

Memorize the freeze frame data. (For test mode \$02)

# DIAGNOSTIC TROUBLE CODE (DTC) DETECTING CRITERIA

## GENERAL DESCRIPTION

### DU:DTC P1700 — THROTTLE POSITION SENSOR CIRCUIT MALFUNCTION FOR AT —

#### 1. OUTLINE OF DIAGNOSIS

Judge NG when the voltage from throttle sensor is out of specified value.

#### 2. COMPONENT DESCRIPTION

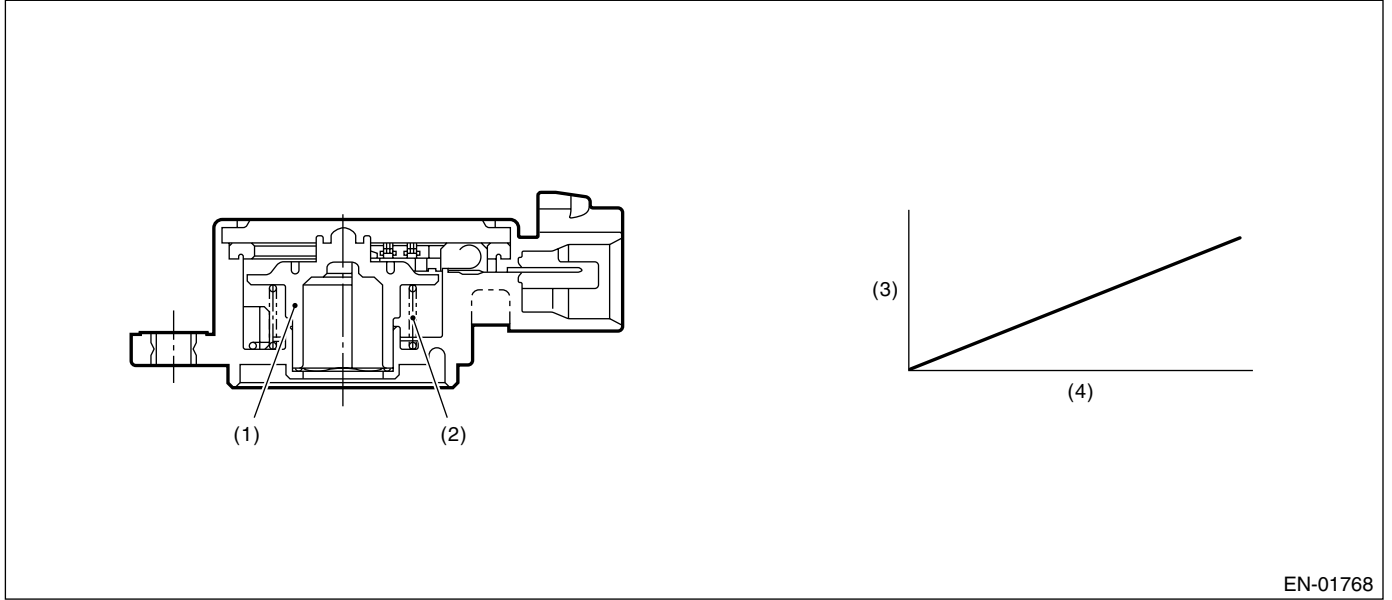

EN-01768

- (1) Rotor
- (2) Return spring
- (3) Voltage (V)
- (4) Throttle valve angle (°)

#### 3. ENABLE CONDITION

Secondary Parameters	Enable Conditions
None	

#### 4. GENERAL DRIVING CYCLE

Always perform the diagnosis.

#### 5. DIAGNOSTIC METHOD

##### Judgment Value

Malfunction Criteria	Threshold Value
Output voltage	$\leq 0.1$ or $\geq 4.6$ V

**Time Needed for Diagnosis:** 63.75 seconds

**Malfunction Indicator Light Illumination:** Detect when malfunction occurs in two continuous driving cycles.

#### 6. DTC CLEAR CONDITION

- When the OK idling cycle was completed 40 times in a row
- When "Clear Memory" was performed

#### 7. MALFUNCTION INDICATOR LIGHT CLEAR CONDITION

- When the OK driving cycle was completed 3 times in a row
- When "Clear Memory" was performed

# DIAGNOSTIC TROUBLE CODE (DTC) DETECTING CRITERIA

GENERAL DESCRIPTION

---

## 8. FAIL SAFE

Make the throttle angle to 3/8, and the line pressure and 2-4B pressure to maximum.

## 9. ECM OPERATION AT DTC SETTING

Memorize the freeze frame data. (For test mode \$02)

# DIAGNOSTIC TROUBLE CODE (DTC) DETECTING CRITERIA

## GENERAL DESCRIPTION

### DV:DTC P1711 — ENGINE TORQUE CONTROL SIGNAL #1 CIRCUIT MALFUNCTION —

#### 1. OUTLINE OF DIAGNOSIS

Judge NG when detecting the difference 250 times in a row by comparing the CPU output with signal line output every 10 milliseconds.

#### 2. ENABLE CONDITION

Secondary Parameters	Enable Conditions
None	

#### 3. GENERAL DRIVING CYCLE

Always perform the diagnosis.

#### 4. DIAGNOSTIC METHOD

##### Judgment Value

Malfunction Criteria	Threshold Value
Collector voltage of transistor (Vc) at "ON" signal from TCM	High level
Collector voltage of transistor (Vc) at "OFF" signal from ECM	Low level

**Time Needed for Diagnosis:** 2.5 seconds

**Malfunction Indicator Light Illumination:** Illuminates when malfunction occurs in 2 continuous driving cycles.

#### 5. DTC CLEAR CONDITION

- When the OK idling cycle was completed 40 times in a row
- When "Clear Memory" was performed

#### 6. MALFUNCTION INDICATOR LIGHT CLEAR CONDITION

- When the OK driving cycle was completed 3 times in a row
- When "Clear Memory" was performed

#### 7. FAIL SAFE

None

#### 8. ECM OPERATION AT DTC SETTING

Memorize the freeze frame data. (For test mode \$02)

# DIAGNOSTIC TROUBLE CODE (DTC) DETECTING CRITERIA

GENERAL DESCRIPTION

## DW:DTC P1712 — ENGINE TORQUE CONTROL SIGNAL #2 CIRCUIT MALFUNCTION —

### 1. OUTLINE OF DIAGNOSIS

Judge NG when detecting the difference 250 times in a row by comparing the CPU output with signal line output every 10 milliseconds.

### 2. ENABLE CONDITION

Secondary Parameters	Enable Conditions
None	

### 3. GENERAL DRIVING CYCLE

Always perform the diagnosis.

### 4. DIAGNOSTIC METHOD

#### Judgment Value

Malfunction Criteria	Threshold Value
Vc at "ON" signal from ECM	High level
Vc at "OFF" signal from ECM	Low level

**Time Needed for Diagnosis:** 2.5 seconds

**Malfunction Indicator Light Illumination:** Illuminates when malfunction occurs in 2 continuous driving cycles.

### 5. DTC CLEAR CONDITION

- When the OK idling cycle was completed 40 times in a row
- When "Clear Memory" was performed

### 6. MALFUNCTION INDICATOR LIGHT CLEAR CONDITION

- When the OK driving cycle was completed 3 times in a row
- When "Clear Memory" was performed

### 7. FAIL SAFE

None

### 8. ECM OPERATION AT DTC SETTING

Memorize the freeze frame data. (For test mode \$02)

# DIAGNOSTIC TROUBLE CODE (DTC) DETECTING CRITERIA

## GENERAL DESCRIPTION

### DX:DTC P2096 — POST CATALYST FUEL TRIM SYSTEM TOO LEAN BANK 1 —

#### 1. OUTLINE OF DIAGNOSIS

Detect the malfunction of fuel system from the amount of sub feedback control.

Sub feedback control amount sticks to lean sides during sub feedback control.

Judge NG when the rear oxygen sensor output does not come close to target voltage (slice level).

#### 2. COMPONENT DESCRIPTION

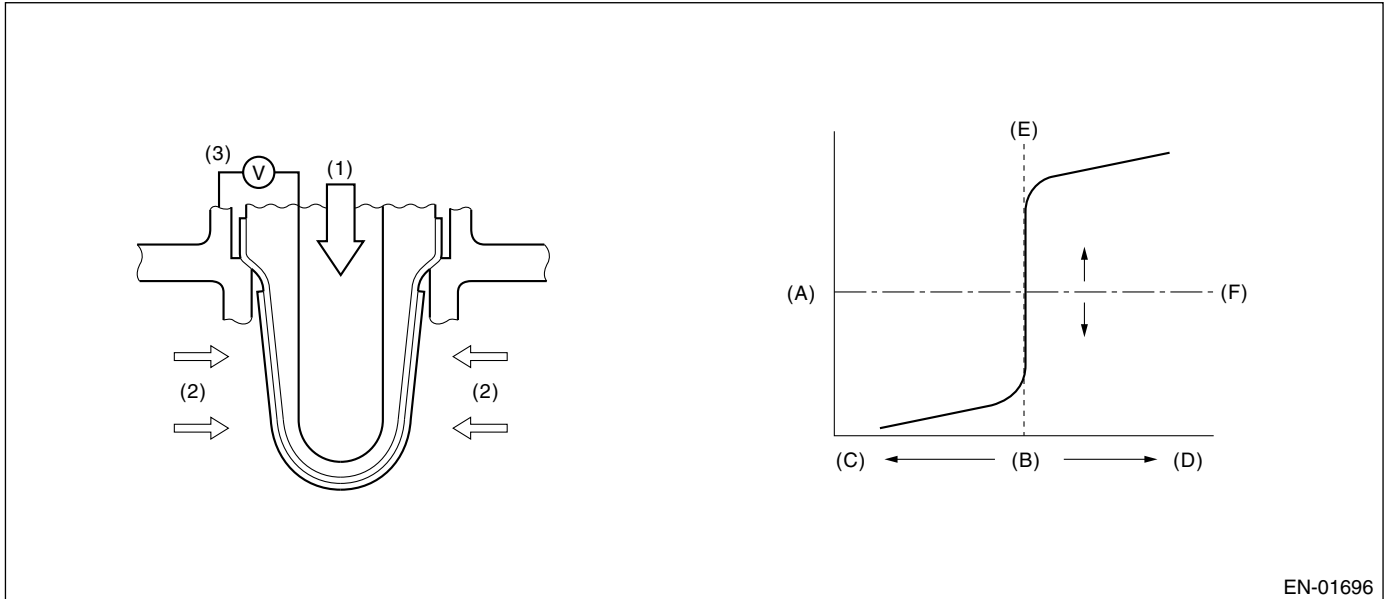

EN-01696

- (1) Atmosphere
- (2) Exhaust gas
- (3) Electromotive force

- (A) Electromotive force
- (B) Air fuel ratio
- (C) Rich

- (D) Lean
- (E) Theoretical air fuel ratio
- (F) Comparative voltage

#### 3. ENABLE CONDITION

Secondary Parameters	Enable Conditions
Main feedback	In operation
Sub feedback	In operation
Amount of intake air	$\geq 16 \text{ g (0.56 oz)/sec}$
Sub feedback	Sticks to the limit value

#### 4. GENERAL DRIVING CYCLE

Perform the diagnosis continuously at a constant speed of more than 80 km/h (50 MPH).



# DIAGNOSTIC TROUBLE CODE (DTC) DETECTING CRITERIA

GENERAL DESCRIPTION

## 5. DIAGNOSTIC METHOD

### • Abnormality Judgment

Calculate the continuous time from the sticking of sub feedback control amount to lean side and cumulative deviation (sumdelo2) of rear oxygen sensor voltage and target voltage.

Judge NG when the malfunction criteria below are completed after 300 seconds have passed continuously.

### • Judgment Value

Malfunction Criteria	Threshold Value
$\text{sumdelo2} = \text{sumdelo2} + (\text{rvo2} - \text{rsl})$ where: rvo2 = sensing voltage of O <sub>2</sub> sensor rsl = target voltage of O <sub>2</sub> sensor	> -2000 V

**Time Needed for Diagnosis:** 300 seconds

**Malfunction Indicator Light Illumination:** Illuminates when malfunction occurs in 2 continuous driving cycles.

### • Normality Judgment

Judge OK and clear the NG when the rear oxygen output is reversed, and during 10 seconds after that, the sub feedback control amount does not stick to rich or lean sides.

## 6. DTC CLEAR CONDITION

- When the OK idling cycle was completed 40 times in a row
- When "Clear Memory" was performed

## 7. MALFUNCTION INDICATOR LIGHT CLEAR CONDITION

- When OK with similar drive in 3 drive cycles.
- When "Clear Memory" was performed

## 8. FAIL SAFE

None

## 9. ECM OPERATION AT DTC SETTING

Memorize the freeze frame data. (For test mode \$02)

# DIAGNOSTIC TROUBLE CODE (DTC) DETECTING CRITERIA

## GENERAL DESCRIPTION

### DY:DTC P2097 — POST CATALYST FUEL TRIM SYSTEM TOO RICH BANK 1 —

#### 1. OUTLINE OF DIAGNOSIS

Detect the malfunction of fuel system from the amount of sub feedback control.

Sub feedback control amount sticks to rich sides during sub feedback control.

Judge NG when the rear oxygen sensor output does not come close to target voltage (slice level).

#### 2. COMPONENT DESCRIPTION

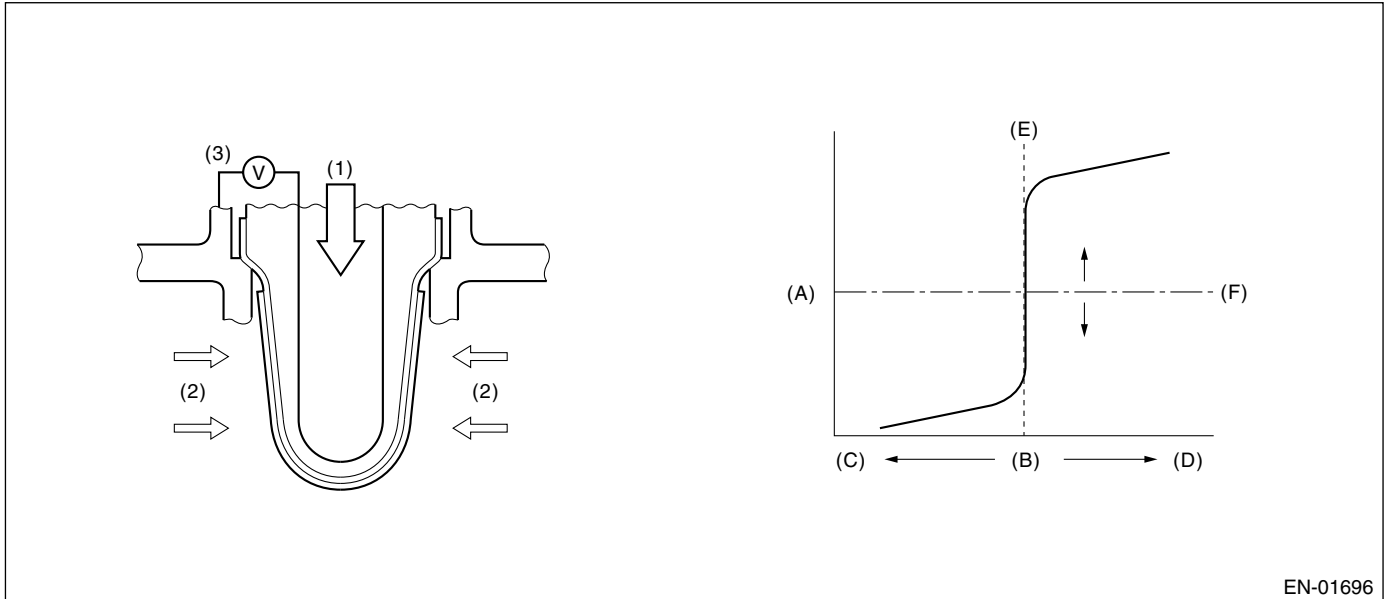

EN-01696

- (1) Atmosphere
- (2) Exhaust gas
- (3) Electromotive force

- (A) Electromotive force
- (B) Air fuel ratio
- (C) Rich

- (D) Lean
- (E) Theoretical air fuel ratio
- (F) Comparative voltage

#### 3. ENABLE CONDITION

Secondary Parameters	Enable Conditions
Main feedback	In operation
Sub feedback	In operation
Amount of intake air	$\geq 16 \text{ g (0.56 oz)/sec}$
Sub feedback	Sticks to the limit value (rich side)

#### 4. GENERAL DRIVING CYCLE

Perform the diagnosis continuously at a constant speed of more than 80 km/h (50 MPH).

# DIAGNOSTIC TROUBLE CODE (DTC) DETECTING CRITERIA

GENERAL DESCRIPTION

## 5. DIAGNOSTIC METHOD

### • Abnormality Judgment

Calculate the continuous time from the sticking of sub feedback control amount to rich side and cumulative deviation (sumdelo2) of rear oxygen sensor voltage and target voltage.

Judge NG when the malfunction criteria below are completed after 300 seconds have passed continuously.

### • Judgment Value

Malfunction Criteria	Threshold Value
$\text{sumdelo2} = \text{sumdelo2} + (\text{rvo2} - \text{rsl})$ where: rvo2 = sensing voltage of O <sub>2</sub> sensor rsl = target voltage of O <sub>2</sub> sensor	> 478 V

**Time Needed for Diagnosis:** 300 seconds

**Malfunction Indicator Light Illumination:** Illuminates when malfunction occurs in 2 continuous drive cycles.

### • Normality Judgment

Judge OK and clear the NG when the rear oxygen output is reversed, and during 10 seconds after that, the sub feedback control amount does not stick to rich or lean sides.

## 6. DTC CLEAR CONDITION

- When the OK idling cycle was completed 40 times in a row
- When "Clear Memory" was performed

## 7. MALFUNCTION INDICATOR LIGHT CLEAR CONDITION

- When OK with similar drive in 3 drive cycles.
- When "Clear Memory" was performed

## 8. FAIL SAFE

None

## 9. ECM OPERATION AT DTC SETTING

Memorize the freeze frame data. (For test mode \$02)

# DIAGNOSTIC TROUBLE CODE (DTC) DETECTING CRITERIA

GENERAL DESCRIPTION

---

**MEMO:**