

# EXHAUST

# *EX(H6DO)*

---

	<b>Page</b>
1. General Description .....	2
2. Front Exhaust Pipe.....	5
3. Rear Exhaust Pipe .....	8
4. Muffler .....	9



# GENERAL DESCRIPTION

EXHAUST

## 1. General Description

### A: COMPONENT

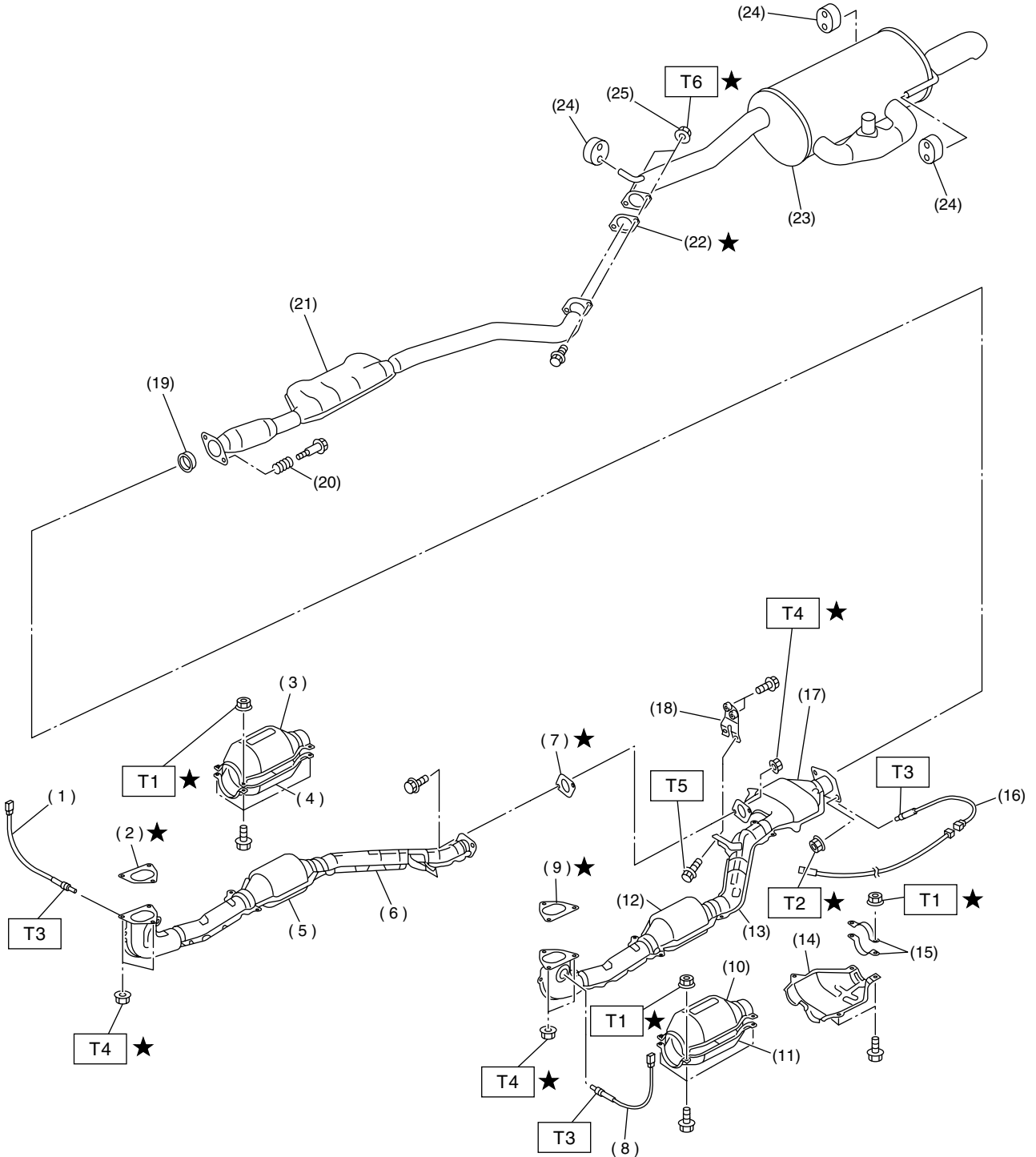

EX-00055

# GENERAL DESCRIPTION

EXHAUST

---

(1) Front oxygen (A/F) sensor (RH)	(11) Lower front catalytic converter cover (LH)	(22) Gasket
(2) Gasket (RH)		(23) Muffler
(3) Upper front catalytic converter cover (RH)	(12) Front catalytic converter (LH)	(24) Cushion rubber
(4) Lower front catalytic converter cover (RH)	(13) Front exhaust pipe (LH)	(25) Self-locking nut
(5) Front catalytic converter (RH)	(14) Lower rear catalytic converter cover	
(6) Front exhaust pipe (RH)	(15) Clamp	
(7) Gasket (RH)	(16) Rear oxygen sensor	
(8) Front oxygen (A/F) sensor (LH)	(17) Rear catalytic converter	
(9) Gasket (LH)	(18) Bracket	
(10) Upper front catalytic converter cover (LH)	(19) Gasket	
	(20) Spring	
	(21) Rear exhaust pipe	

---

**Tightening torque: N·m (kgf-m, ft-lb)**

**T1: 13 (1.3, 9.4)**

**T2: 18 (1.8, 13.0)**

**T3: 21 (2.1, 15)**

**T4: 30 (3.1, 22.4)**

**T5: 35 (3.6, 26.0)**

**T6: 48 (4.9, 35.4)**

---

## GENERAL DESCRIPTION

### EXHAUST

---

#### **B: CAUTION**

- Wear working clothing, including a cap, protective goggles, and protective shoes during operation.
- Remove contamination including dirt and corrosion before removal, installation or disassembly.
- Keep the disassembled parts in order and protect them from dust or dirt.
- Before removal, installation or disassembly, be sure to clarify the failure. Avoid unnecessary removal, installation, disassembly, and replacement.
- Be careful not to burn your hands, because each part on the vehicle is hot after running.
- Be sure to tighten fasteners including bolts and nuts to the specified torque.
- Place shop jacks or safety stands at the specified points.
- Before disconnecting electrical connectors of sensors or units, be sure to disconnect ground cable from battery.

## 2. Front Exhaust Pipe

### A: REMOVAL

- 1) Remove battery.
- 2) Remove air cleaner case and air intake duct.  
<Ref. to IN(H6DO)-5, REMOVAL, Air Cleaner.>  
and <Ref. to IN(H6DO)-7, REMOVAL, Air Intake Duct.>
- 3) Disconnect front oxygen (A/F) sensor connector.

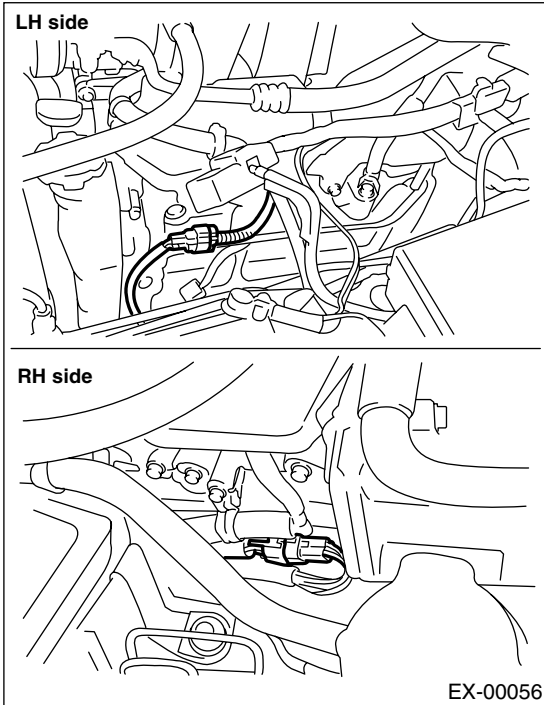

- 4) Lift-up the vehicle.
- 5) Remove under cover.

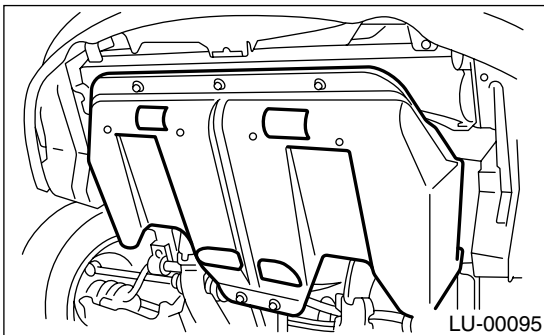

- 6) Disconnect rear oxygen sensor connector.

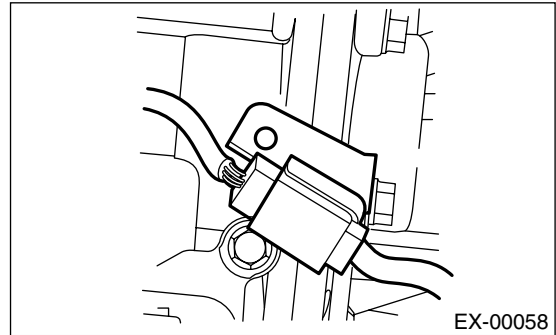

- 7) Separate front exhaust pipe assembly from rear exhaust pipe.

**WARNING:**  
Be careful, exhaust pipe is hot.

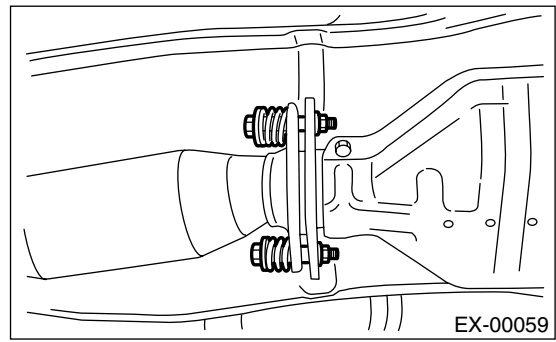

- 8) Remove nuts which hold front exhaust pipe onto cylinder heads.

**CAUTION:**  
Be careful not to pull down front exhaust pipe assembly.

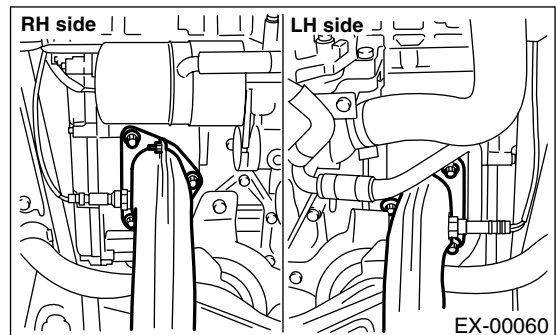

# FRONT EXHAUST PIPE

## EXHAUST

9) Remove bolt which secures front exhaust pipe assembly to hanger bracket.

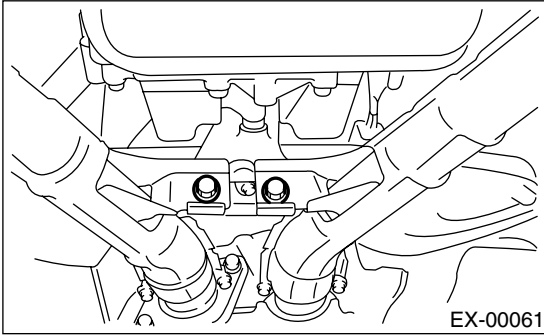

10) Remove front exhaust pipe from the vehicle.

### CAUTION:

- Be careful not to let front exhaust pipe assembly fall off when removing as it is quite heavy.
- After removing front exhaust assembly, do not apply excessive pulling force on rear exhaust pipe.

11) Separate front exhaust pipe (RH) from front exhaust pipe assembly.

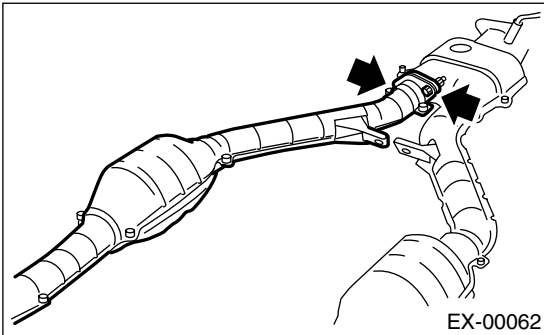

## B: INSTALLATION

1) Install front exhaust pipe (RH) to front exhaust pipe assembly.

### NOTE:

Replace gaskets with new ones.

### Tightening torque:

**30 N·m (3.1 kgf-m, 22.4 ft-lb)**

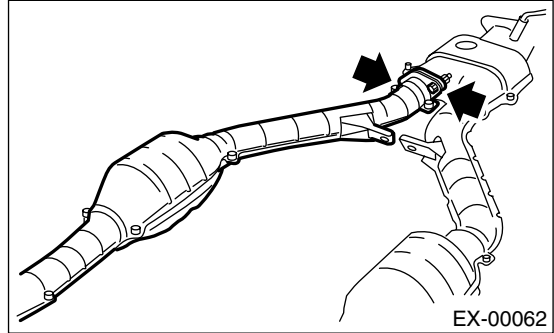

2) Install front exhaust pipe assembly to the vehicle.

3) Temporarily tighten bolt which installs front exhaust pipe assembly to hanger bracket.

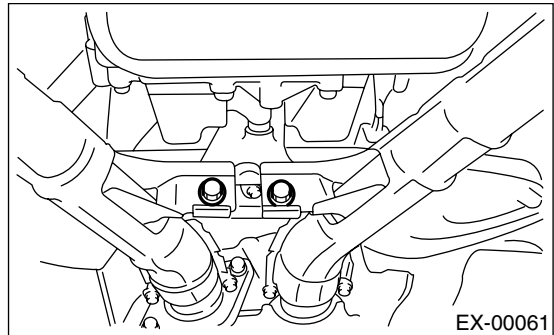

4) Tighten nuts which hold front exhaust pipe onto cylinder heads.

### Tightening torque:

**30 N·m (3.1 kgf-m, 22.4 ft-lb)**

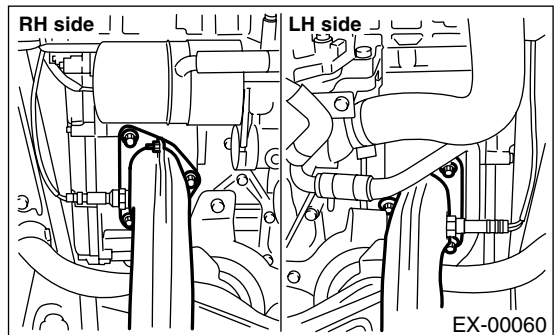

- 5) Install under cover.
- 6) Tighten bolts which install front exhaust pipe to rear exhaust pipe.

**Tightening torque:**  
**18 N·m (1.8 kgf-m, 13.0 ft-lb)**

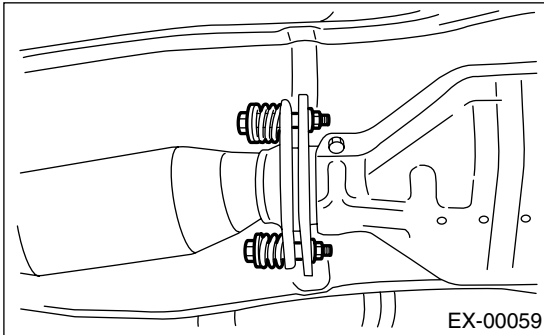

- 7) Tighten bolt which holds front exhaust pipe assembly to hanger bracket.

**Tightening torque:**  
**35 N·m (3.6 kgf-m, 26.0 ft-lb)**

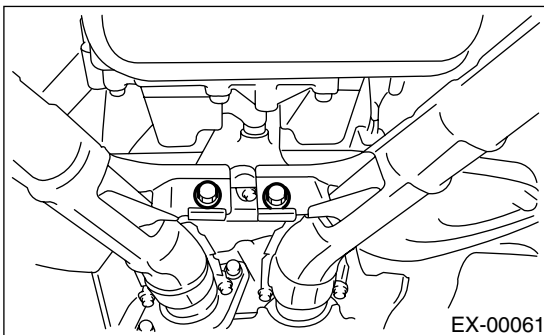

- 8) Connect rear oxygen sensor connector.

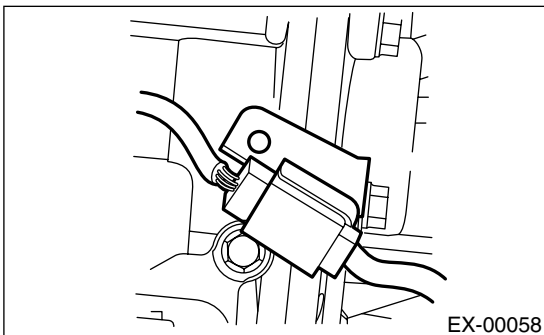

- 9) Install under cover.
- 10) Lower the vehicle.

- 11) Connect front oxygen (A/F) sensor connectors.

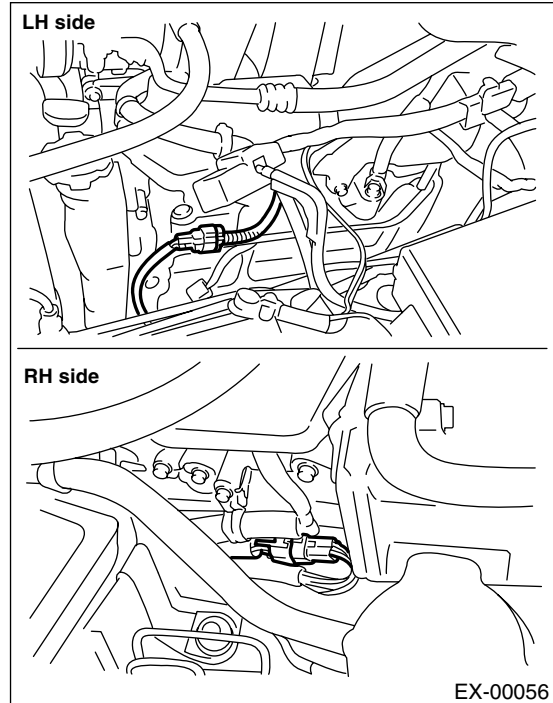

- 12) Install air cleaner case and air intake duct. <Ref. to IN(H6DO)-5, INSTALLATION, Air Cleaner.> and <Ref. to IN(H6DO)-7, INSTALLATION, Air Intake Duct.>
- 13) Install battery.

## C: INSPECTION

- 1) Make sure there are no exhaust leaks from connections and welds.
- 2) Make sure there are no holes or rusting.

# REAR EXHAUST PIPE

## EXHAUST

### 3. Rear Exhaust Pipe

#### A: REMOVAL

1) Separate rear exhaust pipe from front exhaust pipe.

#### CAUTION:

Be careful, exhaust pipe is hot.

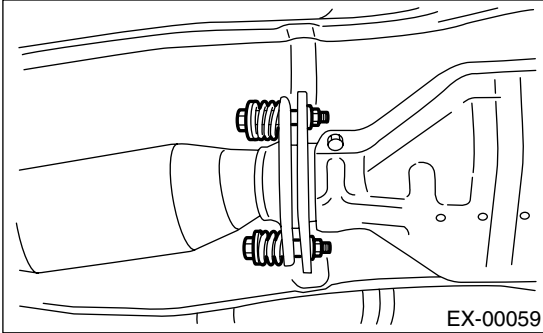

2) Separate rear exhaust pipe from muffler.

#### CAUTION:

Be careful not to pull down rear exhaust pipe.

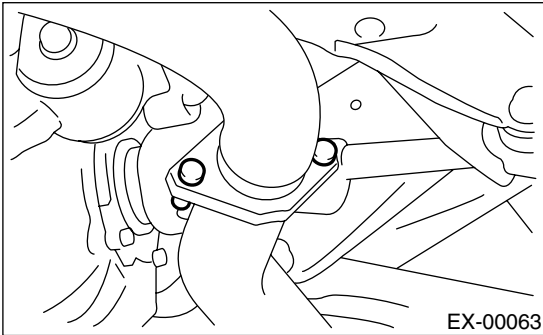

3) Remove rear exhaust pipe.

#### B: INSTALLATION

#### NOTE:

Replace gaskets and self-lock nut with new ones.

1) Install rear exhaust pipe to muffler.

#### Tightening torque:

**48 N·m (4.9 kgf-m, 35.4 ft-lb)**



2) Install rear exhaust pipe to front exhaust pipe.

#### Tightening torque:

**18 N·m (1.8 kgf-m, 13.0 ft-lb)**

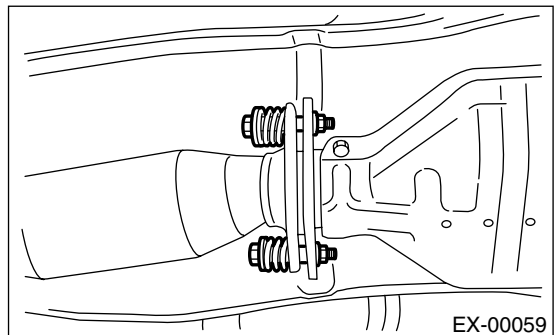

#### C: INSPECTION

1) Make sure there are no exhaust leaks from connections and welds.

2) Make sure there are no holes or rusting.

3) Make sure the cushion rubber is not worn or cracked.



## 4. Muffler

### A: REMOVAL

1) Separate muffler from rear exhaust pipe.

**CAUTION:**

Be careful, exhaust pipe is hot.



2) Remove left and right rubber cushions.

**CAUTION:**

Be careful not to drop the muffler during removal.

**NOTE:**

To facilitate removal, apply a coat of SUBARU CRC to mating area of rubber cushions in advance.

**SUBARU CRC (Part No. 004301003)**

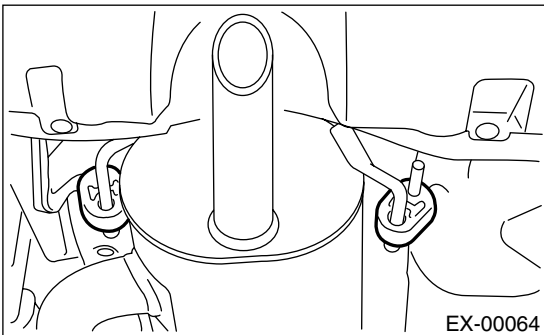

3) Remove front rubber cushion, and detach muffler assembly.

**NOTE:**

To facilitate removal, apply a coat of SUBARU CRC to mating area of rubber cushion in advance.

**SUBARU CRC (Part No. 004301003)**

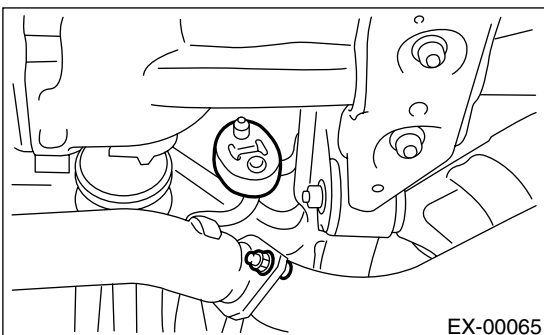

### B: INSTALLATION

Install in the reverse order of removal.

**NOTE:**

Replace gasket and self-lock nut with a new one.

**Tightening torque:**

**48 N·m (4.9 kgf-m, 35.4 ft-lb)**

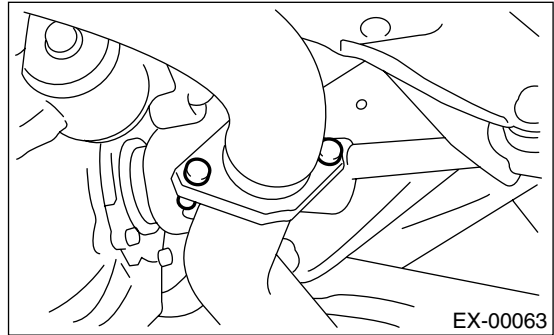

### C: INSPECTION

- 1) Make sure there are no exhaust leaks from connections and welds.
- 2) Make sure there are no holes or rusting.
- 3) Make sure the cushion rubber is not worn or cracked.

# MUFFLER

EXHAUST

---

**MEMO:**