

# LUBRICATION

# *LU(H6DO)*

---

	<b>Page</b>
1. General Description .....	2
2. Oil Pressure System .....	8
3. Engine Oil.....	10
4. Oil Pump .....	12
5. Oil Pump Relief Valve .....	14
6. Oil Pan and Strainer.....	15
7. Oil Pressure Switch.....	17
8. Engine Oil Filter.....	18
9. Oil Cooler .....	19
10. Engine Lubrication System Trouble in General.....	21



# GENERAL DESCRIPTION

## LUBRICATION

### 1. General Description

#### A: SPECIFICATIONS

Lubrication method		Forced lubrication	
Oil pump	Pump type	Trochoid type	
	Number of teeth	Inner rotor	9
		Outer rotor	10
	Outer rotor diameter × thickness		78 × 11 mm (3.07 × 0.43 in)
	Tip clearance between inner and outer rotor	Standard	0.04 — 0.14 mm (0.0016 — 0.0055 in)
	Side clearance between inner rotor and pump case	Standard	0.02 — 0.07 mm (0.0008 — 0.0028 in)
	Case clearance between outer rotor and pump case	Standard	0.10 — 0.18 mm (0.0039 — 0.0071 in)
Oil filter	Type	Full-flow filter type	
	Filtration area	1,300 cm <sup>2</sup> (201.5 sq in)	
	By-pass valve opening pressure	160 kPa (1.63 kg/cm <sup>2</sup> , 23 psi)	
	Outer diameter × width	80 × 75 mm (3.15 × 2.95 in)	
	Oil filter to engine thread size	M 20 × 1.5	
Relief valve operation pressure		588 kPa (6 kg/cm <sup>2</sup> , 85 psi)	
Oil pressure switch	Type	Immersed contact point type	
	Working voltage — wattage	12 V — 3.4 W or less	
	Warning light activation pressure	15 kPa (0.153 kg/cm <sup>2</sup> , 2.18 psi)	
	Proof pressure	More than 980 kPa (9.993 kg/cm <sup>2</sup> , 142 psi)	
Oil capacity	Total capacity	6.6 L (7.0 US qt, 5.8 Imp qt)	
	Engine oil amount for refill	5.3 L (5.6 US qt, 4.6 Imp qt)	

# GENERAL DESCRIPTION

LUBRICATION

---

**MEMO:**

**LU(H6DO)-3**

# GENERAL DESCRIPTION

LUBRICATION

## B: COMPONENT

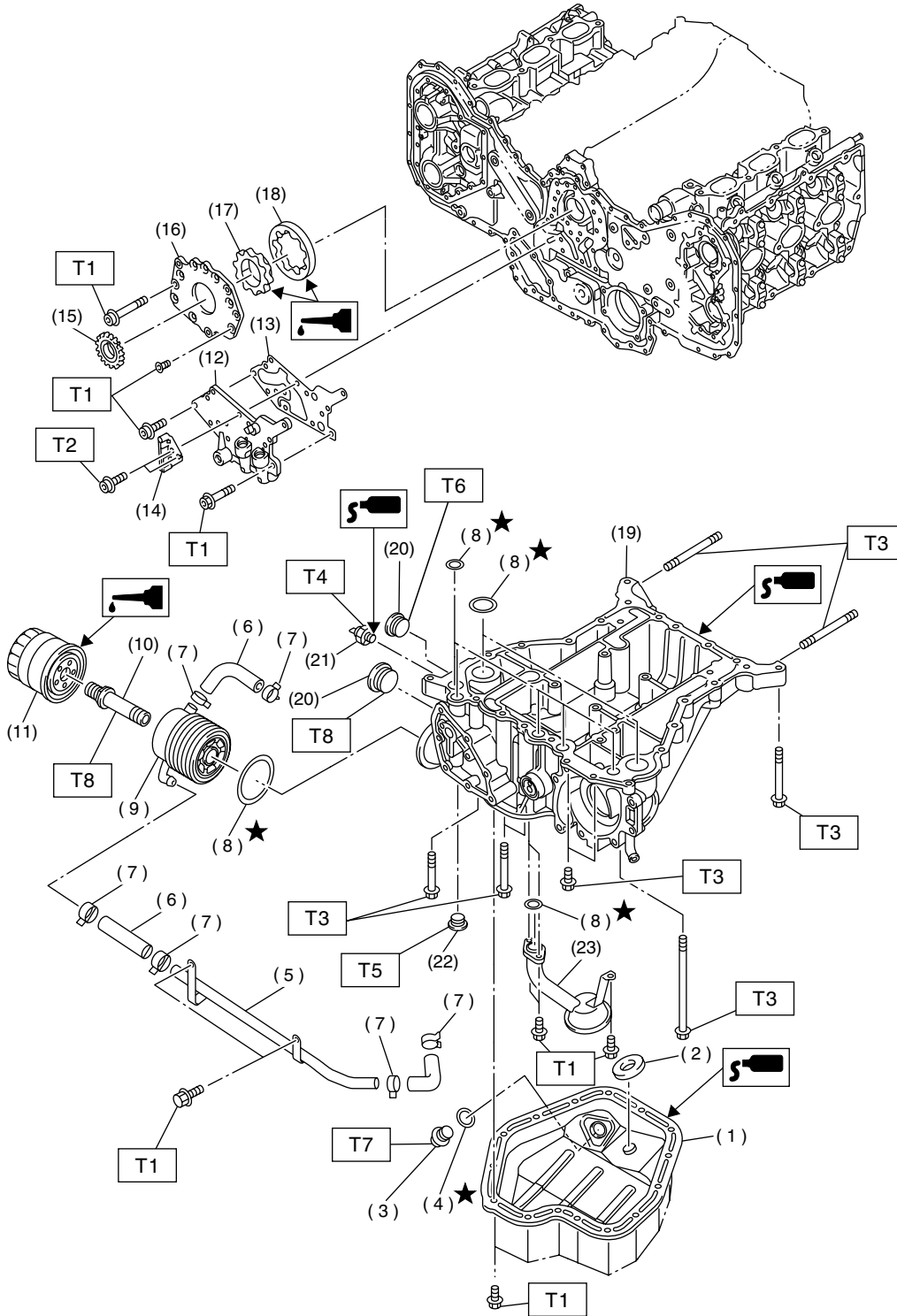

LU-00109

LU(H6DO)-4

# GENERAL DESCRIPTION

LUBRICATION

---

(1) Oil pan lower	(13) Relief valve case gasket	<b><i>Tightening torque: N-m (kgf-m, ft-lb)</i></b>
(2) Magnet	(14) Chain guide (center)	<b><i>T1: 6.4 (0.65, 4.7)</i></b>
(3) Drain plug	(15) Crank sprocket	<b><i>T2: 7.8 (0.80, 5.8)</i></b>
(4) Gasket	(16) Oil pump cover	<b><i>T3: 18 (1.8, 13)</i></b>
(5) Oil cooler pipe	(17) Inner rotor	<b><i>T4: 25 (2.5, 18)</i></b>
(6) Hose	(18) Outer rotor	<b><i>T5: 34 (3.5, 25)</i></b>
(7) Clamp	(19) Oil pan upper	<b><i>T6: 37 (3.8, 27)</i></b>
(8) O-ring	(20) Plug	<b><i>T7: 44 (4.5, 33)</i></b>
(9) Oil cooler	(21) Oil pressure switch	<b><i>T8: 54 (5.5, 40)</i></b>
(10) Connector	(22) Plug	
(11) Oil filter	(23) Oil strainer	
(12) Relief valve case		

---

## GENERAL DESCRIPTION

### LUBRICATION

#### C: CAUTION

- Wear working clothing, including a cap, protective goggles, and protective shoes during operation.
- Remove contamination including dirt and corrosion before removal, installation or disassembly.
- Keep the disassembled parts in order and protect them from dust or dirt.
- Before removal, installation or disassembly, be sure to clarify the failure. Avoid unnecessary removal, installation, disassembly, and replacement.
- Be careful not to burn your hands, because each part in the vehicle is hot after running.
- Be sure to tighten fasteners including bolts and nuts to the specified torque.
- Place shop jacks or safety stands at the specified points.
- Before disconnecting electrical connectors of sensors or units, be sure to disconnect ground cable from battery.

#### D: PREPARATION TOOL

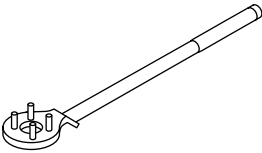
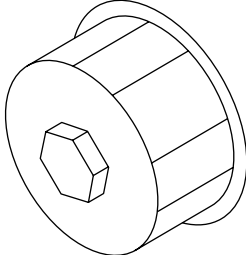
ILLUSTRATION	TOOL NUMBER	DESCRIPTION	REMARKS
 ST-499977100	499977100	CRANK PULLEY WRENCH	Used for stopping rotation of crankshaft pulley when loosening and tightening crankshaft pulley bolt.
 ST-498547000	498547000	OIL FILTER WRENCH	Used for removing and installing oil filter.

# GENERAL DESCRIPTION

LUBRICATION

---

**MEMO:**

**LU(H6DO)-7**

# OIL PRESSURE SYSTEM

LUBRICATION

## 2. Oil Pressure System

### A: SCHEMATIC

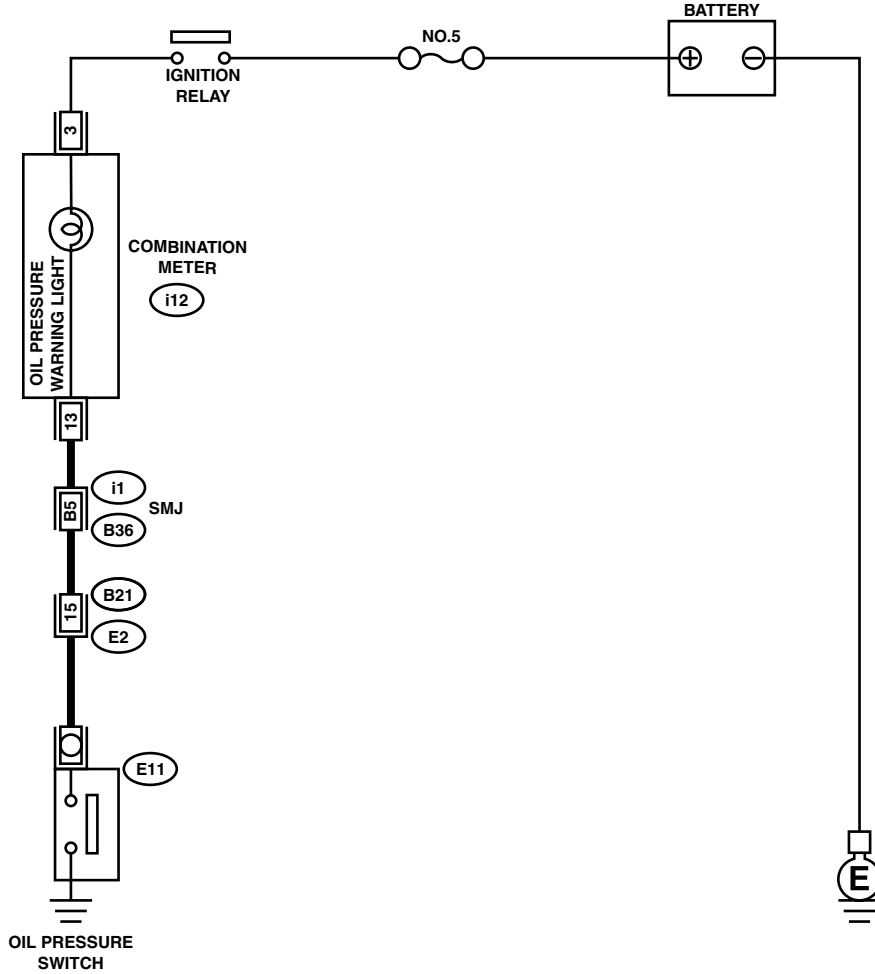

i12 (GREEN)

1	2	3	4	5	6
7	8	9	10	11	12
13	14				

B21 (GRAY)

1	2	3	4
5	6	7	8
9	10	11	12
13	14	15	16
17	18	19	20

B36

A1	A2	A3	A4	A5	A6
B1	B2	B3	B4	B5	B6
C1	C2	C3	C4	C5	C6
D1	D2	D3	D4	D5	D6
E1	E2	E3	E4	E5	E6
F1	F2	F3	F4	F5	F6
G1	G2	G3	G4	G5	G6
H1	H2	H3	H4	H5	H6
I1	I2	I3	I4	I5	I6
J1	J2	J3	J4	J5	J6
K1	K2	K3	K4	K5	K6
L1	L2	L3	L4	L5	L6
M1	M2	M3	M4	M5	M6
N1	N2	N3	N4	N5	N6
O1	O2	O3	O4	O5	O6
P1	P2	P3	P4	P5	P6

LU-00110



## B: INSPECTION

Step	Check	Yes	No
<b>1</b> <b>CHECK COMBINATION METER.</b> 1) Turn ignition switch to ON. (engine OFF) 2) Check other warning lights.	Do the warning lights go on?	Go to step 2.	Repair or replace the combination meter. <Ref. to IDI-4, INSPECTION, Combination Meter System.>
<b>2</b> <b>CHECK HARNESS CONNECTOR BETWEEN COMBINATION METER AND OIL PRESSURE SWITCH.</b> 1) Turn ignition switch to OFF. 2) Disconnect connector from the oil pressure switch. 3) Turn ignition switch ON. 4) Measure the voltage of harness between the combination meter connector and chassis ground. <b>Connector &amp; terminal</b> <b>(E11) No. 1 — Chassis ground:</b>	Is the measured value more than 10 V?	Replace oil pressure switch.	Go to step 3.
<b>3</b> <b>CHECK COMBINATION METER.</b> 1) Turn ignition switch to OFF. 2) Remove the combination meter. 3) Measure the resistance of the combination meter. <b>Terminals</b> <b>No. 13 — No. 3:</b>	Is the measured value less than 10 Ω?	Replace the harness connector between combination meter and oil pressure switch.	Repair or replace the combination meter and the oil pressure switch warning light bulb.

# ENGINE OIL

## LUBRICATION

### 3. Engine Oil

#### A: INSPECTION

- 1) Park vehicle on a level surface.
- 2) Remove oil level gauge and wipe it clean.
- 3) Reinsert the level gauge all the way. Be sure that the level gauge is correctly inserted and in the proper orientation.
- 4) Remove it again and note the reading. If the engine oil level is below the "L" line, add oil to bring the level up to the "F" line.
- 5) After turning off the engine, wait a few minutes for the oil to drain back into the oil pan before checking the level.
- 6) To prevent overfilling the engine oil, do not add oil above the "F" line when the engine is cold.

#### NOTE:

Just after driving or during warm-up, engine oil level may rise above the "F" mark.

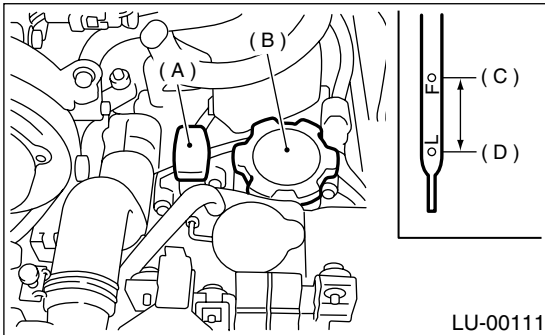

- (A) Oil level gauge
- (B) Engine oil filler cap
- (C) Upper level
- (D) Lower level

#### B: REPLACEMENT

- 1) Open engine oil filler cap for quick draining of the engine oil.

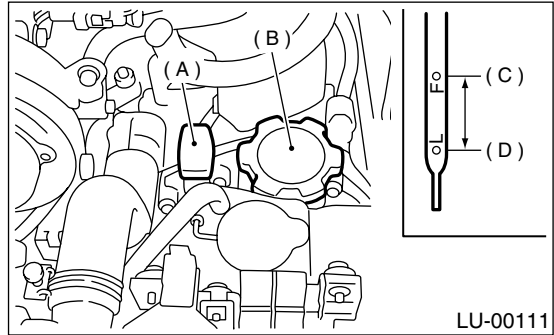

- (A) Oil level gauge
- (B) Engine oil filler cap
- (C) Upper level
- (D) Lower level

- 2) Remove access lid.

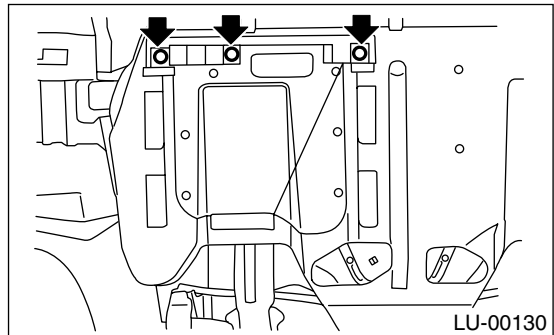

- 3) Drain engine oil by removing engine oil drain plug.

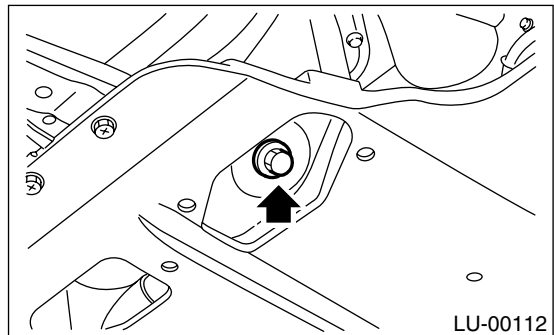

- 4) Replace drain plug gasket.
- 5) Tighten engine oil drain plug after draining engine oil.

**Tightening torque:**

**44 N·m (4.5 kgf-m, 33 ft-lb)**

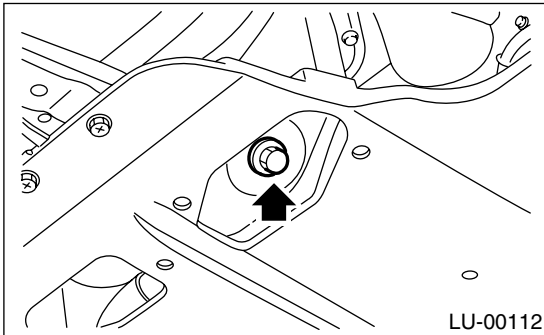

**NOTE:**

If vehicle is used in desert areas with very high temperatures or for other heavy duty applications, the following viscosity oils may be used: ILSAC classification : GF-3 or API classification: SL  
SAE Viscosity No.: 30, 40, 10W-50, 20W-40, 20W-50.

- 7) Close engine oil filler cap.
- 8) Start engine and warm it up for a time.
- 9) After engine stops, recheck the oil level. If necessary, add engine oil up to upper level on level gauge.

6) Fill engine oil through filler pipe up to upper point on level gauge. Make sure that vehicle is placed level when checking oil level. Use engine oil of proper quality and viscosity, selected in accordance with the table in figure.

**Recommended oil**

- ILSAC GF-3, which can be identified with the new API certification mark (Star burst mark)
- API certification SL with the words “ENERGY CONSERVING” (if you cannot obtain the oil with SL grade, you may use SJ grade “ENERGY CONSERVING” oil)
- ACEA specification A1, A2 or A3

**Engine oil amount for preparation (with replacing engine oil):**

**Approx. 5.3 L (5.6 US qt, 4.6 Imp qt)**

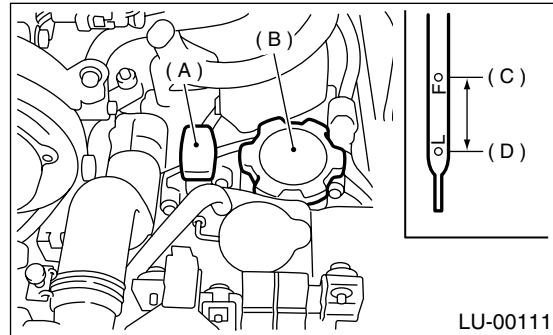

- (A) Oil level gauge
- (B) Engine oil filler cap

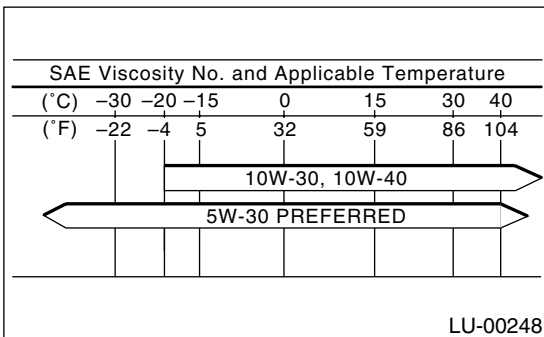

The proper viscosity helps vehicle get good cold and hot starting by reducing viscous friction and thus increasing cranking speed.

**CAUTION:**

When replenishing oil, it does not matter if the oil to be added is a different brand from that in the engine; however, use oil having the ILSAC or API classification and SAE viscosity No. designated by SUBARU.

# OIL PUMP

## LUBRICATION

### 4. Oil Pump

#### A: REMOVAL

- 1) Disconnect ground cable from battery.

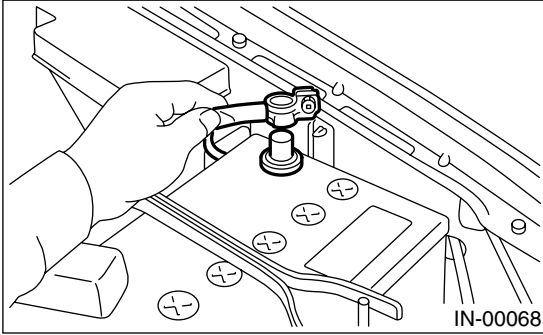

- 2) Lift-up the vehicle.
- 3) Remove under cover.

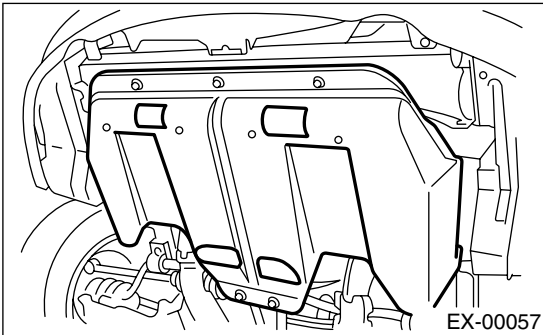

- 4) Drain coolant. <Ref. to CO(H6DO)-18, DRAINING OF ENGINE COOLANT, REPLACEMENT, Engine Coolant.>
- 5) Drain engine oil. <Ref. to LU(H6DO)-10, REPLACEMENT, Engine Oil.>
- 6) Lower the vehicle.
- 7) Remove radiator. <Ref. to CO(H6DO)-23, REMOVAL, Radiator.>
- 8) Remove V-belt. <Ref. to ME(H6DO)-28, REMOVAL, V-belt.>
- 9) Remove front chain cover. <Ref. to ME(H6DO)-39, REMOVAL, Front Chain Cover.>
- 10) Remove timing chain. <Ref. to ME(H6DO)-41, REMOVAL, Timing Chain Assembly.>

- 11) Remove oil pump cover and crankshaft sprocket.

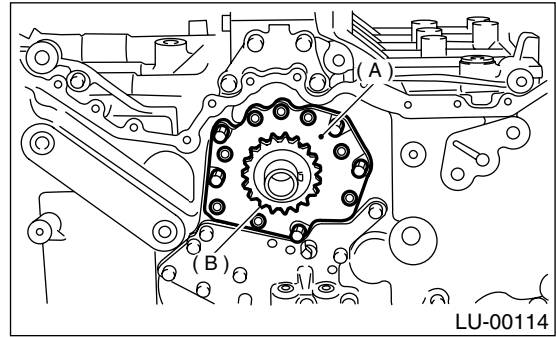

- (A) Oil pump cover
- (B) Crankshaft sprocket

- 12) Remove inner rotor and outer rotor.

#### B: INSTALLATION

- 1) Apply engine oil to the entire surface area of both inner and outer rotor.

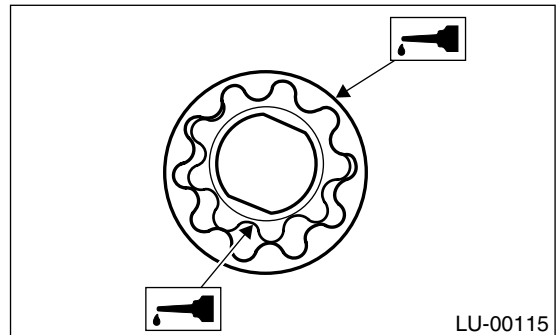

- 2) Install the inner rotor by fitting it into the groove on the crankshaft, and then assemble the outer rotor.
- 3) Install oil pump cover.
- 4) Tighten the bolts in the numerical sequence shown in the figure.

#### CAUTION:

**Make sure that bolt mounting position is correct.**

#### Tightening torque:

**6.4 N·m (0.65 kgf-m, 4.7 ft-lb)**

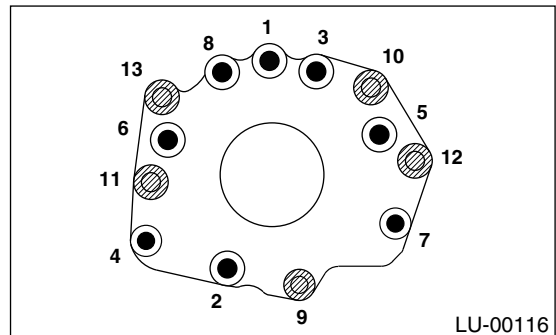

- 5) Install crank sprocket.
- 6) Install timing chain. <Ref. to ME(H6DO)-42, INSTALLATION, Timing Chain Assembly.>
- 7) Install front chain cover. <Ref. to ME(H6DO)-39, INSTALLATION, Front Chain Cover.>
- 8) Install V-belt. <Ref. to ME(H6DO)-28, INSTALLATION, V-belt.>
- 9) Install radiator. <Ref. to CO(H6DO)-24, INSTALLATION, Radiator.>
- 10) Fill coolant. <Ref. to CO(H6DO)-18, FILLING OF ENGINE COOLANT, REPLACEMENT, Engine Coolant.>
- 11) Fill engine oil. <Ref. to LU(H6DO)-10, REPLACEMENT, Engine Oil.>

## C: INSPECTION

### 1. TIP CLEARANCE

Measure the tip clearance of rotors. Replace rotors as a set, if the clearance exceeds the standard value, or the rotors are damaged, dented, partially worn etc.

**Tip clearance:**

**Standard**

**0.04 — 0.14 mm (0.0016 — 0.0055 in)**

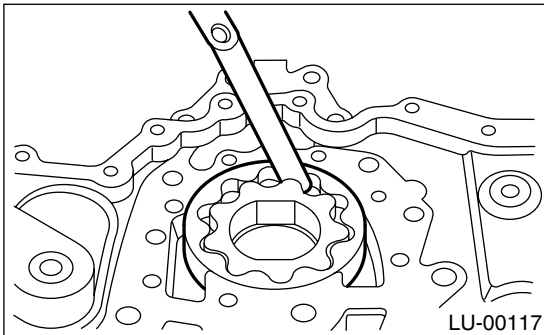

### 2. CASE CLEARANCE

Measure the clearance between the outer rotor and the rear chain cover rotor housing. Replace the rotor, if the clearance exceeds the standard value, or the rotor is damaged, dented, partially worn etc.

**Case clearance:**

**Standard**

**0.10 — 0.18 mm (0.0039 — 0.0071 in)**

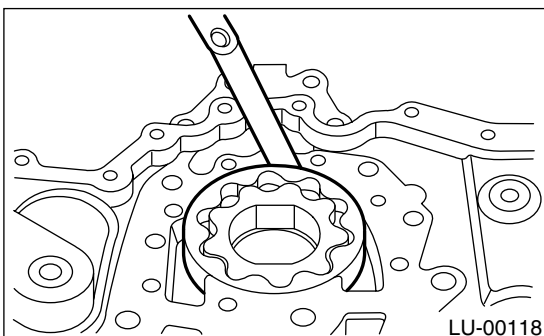

### 3. SIDE CLEARANCE

Measure clearance between oil pump inner rotor and rear chain cover. Replace rotors as a set, if the clearance exceeds the standard value, or the rotors are damaged, dented, partially worn etc.

**Side clearance:**

**Standard**

**0.02 — 0.07 mm (0.0008 — 0.0028 in)**

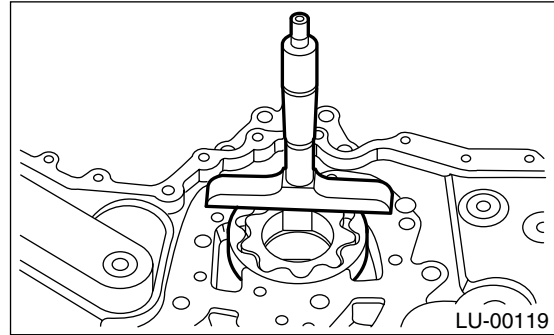

### 4. OIL PUMP CASE

Check the oil pump case for worn shaft hole, clogged oil passage, cracks and other faults.

# OIL PUMP RELIEF VALVE

LUBRICATION

## 5. Oil Pump Relief Valve

### A: REMOVAL

- 1) Disconnect ground cable from battery.

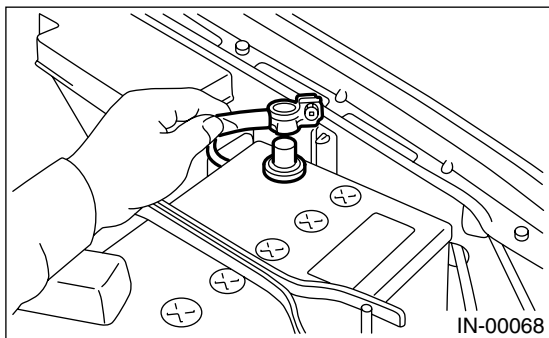

- 2) Lift-up the vehicle.
- 3) Remove under cover.

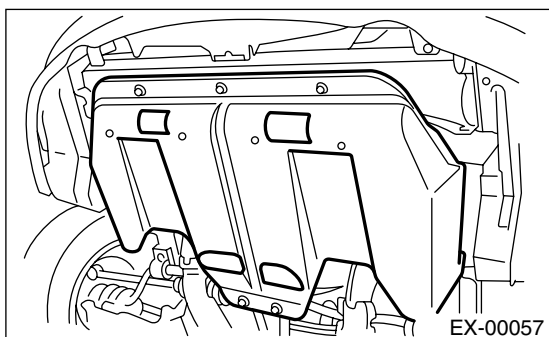

- 4) Drain coolant. <Ref. to CO(H6DO)-18, DRAINING OF ENGINE COOLANT, REPLACEMENT, Engine Coolant.>
- 5) Drain engine oil. <Ref. to LU(H6DO)-10, REPLACEMENT, Engine Oil.>
- 6) Lower the vehicle.
- 7) Remove radiator. <Ref. to CO(H6DO)-23, REMOVAL, Radiator.>
- 8) Remove V-belt. <Ref. to ME(H6DO)-28, REMOVAL, V-belt.>
- 9) Remove front chain cover. <Ref. to ME(H6DO)-39, REMOVAL, Front Chain Cover.>
- 10) Remove timing chain assembly. <Ref. to ME(H6DO)-41, REMOVAL, Timing Chain Assembly.>
- 11) Remove oil pump relief valve.

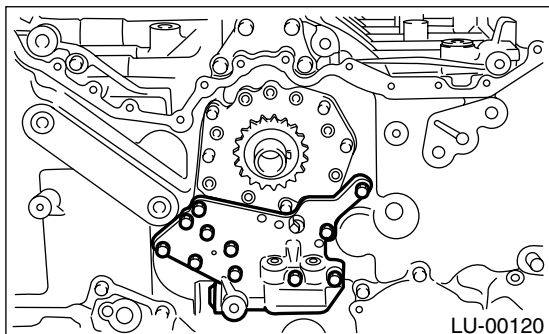

### B: INSTALLATION

- 1) Install oil pump relief valve case and gasket
- 2) Tighten the bolts in the numerical sequence shown in the figure.

**Tightening torque:**

**6.4 N·m (0.65 kgf·m, 4.7 ft·lb)**

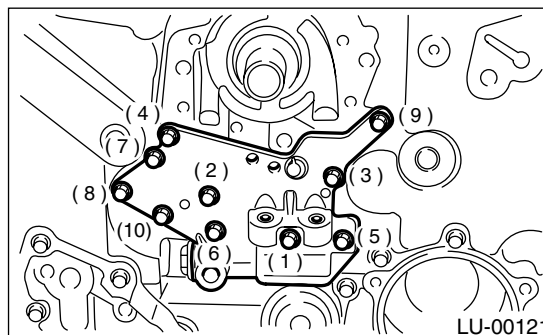

Bolt installation position	Bolt dimension
(1) and (5)	6 x 26
(2), (3), (4) and (9)	6 x 35
(6), (7), (8) and (10)	6 x 16

- 3) Install timing chain assembly. <Ref. to ME(H6DO)-42, INSTALLATION, Timing Chain Assembly.>
- 4) Install front chain cover. <Ref. to ME(H6DO)-39, INSTALLATION, Front Chain Cover.>
- 5) Install V-belt. <Ref. to ME(H6DO)-28, INSTALLATION, V-belt.>
- 6) Install radiator. <Ref. to CO(H6DO)-24, INSTALLATION, Radiator.>
- 7) Fill coolant. <Ref. to CO(H6DO)-18, FILLING OF ENGINE COOLANT, REPLACEMENT, Engine Coolant.>
- 8) Fill engine oil. <Ref. to LU(H6DO)-10, REPLACEMENT, Engine Oil.>

### C: INSPECTION

- Check the oil pump relief valve case for worn shaft hole, clogged oil passage, cracks and other faults.
- Make sure that there are no foreign materials on the gasket filter.

## 6. Oil Pan and Strainer

### A: REMOVAL

#### NOTE:

Oil pan upper cannot be removed from the normal vehicle position. The engine must be separated from the vehicle prior to removal. <Ref. to ME(H6DO)-29, REMOVAL, Engine Assembly.>

- 1) Set the vehicle on lift arms.
- 2) Lift-up the vehicle.
- 3) Remove under cover.

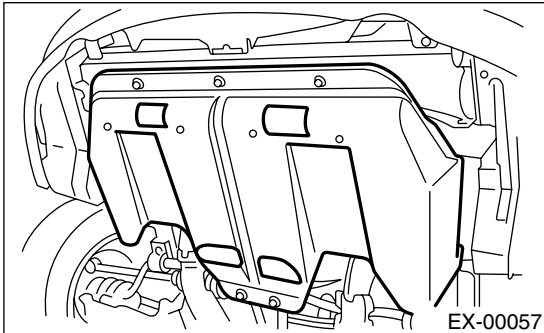

- 4) Drain engine oil.  
Set container under the vehicle, and remove drain plug from oil pan.

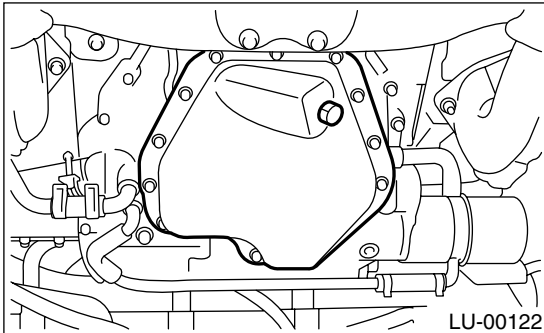

- 5) Insert oil pan cutter blade between upper and lower oil pans.

#### CAUTION:

**Do not use a screwdriver or similar tool in place of oil pan cutter.**

- 6) Remove lower oil pan.

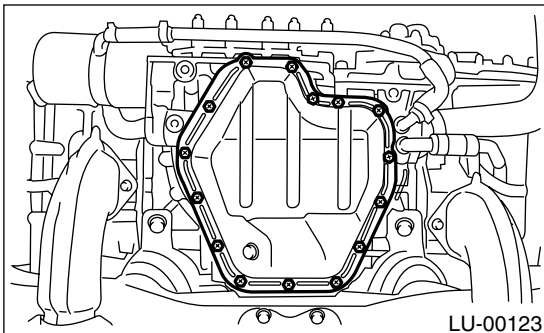

- 7) Remove oil strainer.

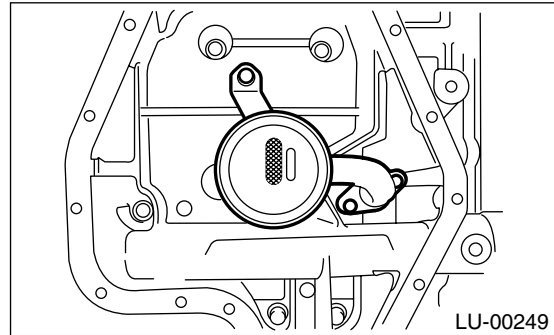

# OIL PAN AND STRAINER

## LUBRICATION

### B: INSTALLATION

#### CAUTION:

Before installing oil pan, clean liquid gasket from lower oil pan and upper oil pan.

1) Install oil strainer onto upper oil pan.

#### CAUTION:

Replace O-ring with a new one.

#### Tightening torque:

**6.4 N·m (0.65 kgf-m, 4.7 ft-lb)**

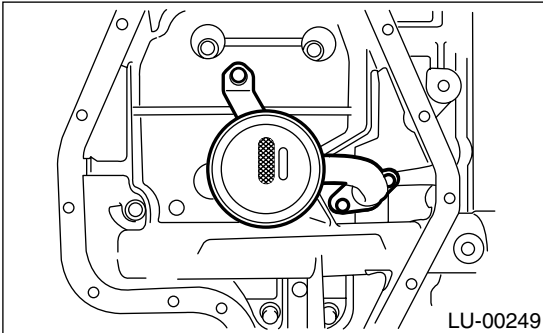

2) Apply liquid gasket to mating surfaces and install oil pan.

#### Liquid gasket:

**THREE BOND 1280B or 1217G**

#### Liquid gasket application diameter:

**5.0±1.0 mm (0.197±0.039 in)**

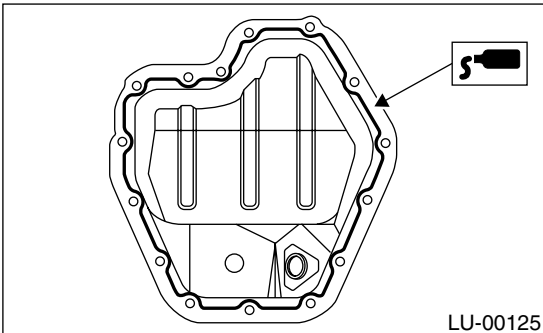

3) Tighten the lower oil pan mounting bolts in the numerical sequence shown in the figure.

#### Tightening torque:

**6.4 N·m (0.65 kgf-m, 4.7 ft-lb)**

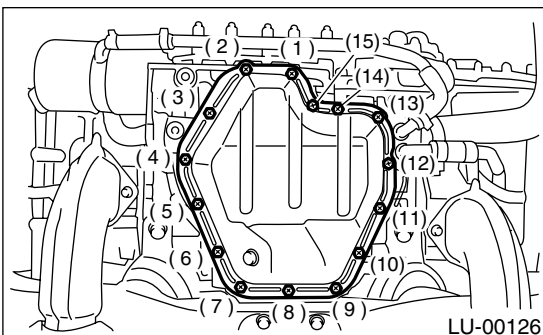

4) Install under cover.

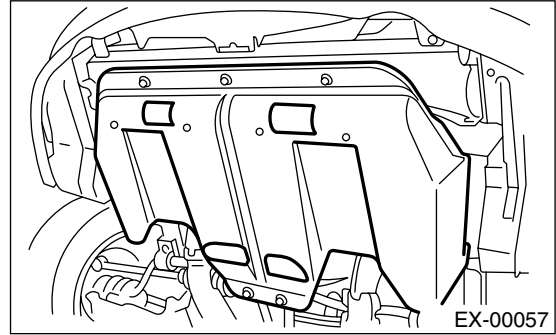

5) Fill engine oil. <Ref. to LU(H6DO)-10, REPLACEMENT, Engine Oil.>

### C: INSPECTION

By visual check make sure oil pan, oil strainer and oil strainer stay are not damaged.



## 7. Oil Pressure Switch

### A: REMOVAL

- 1) Set vehicle on the lift.
- 2) Disconnect ground cable from battery.

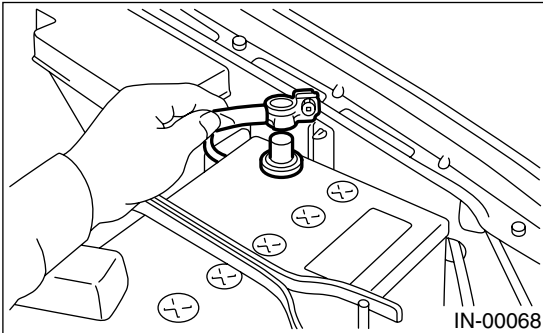

- 3) Drain engine oil. <Ref. to LU(H6DO)-10, REPLACEMENT, Engine Oil.>
- 4) Lift-up the vehicle.
- 5) Remove under cover.
- 6) Disconnect terminal from oil pressure switch.

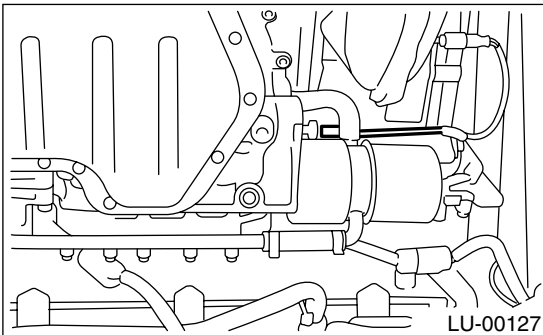

- 7) Remove oil pressure switch.

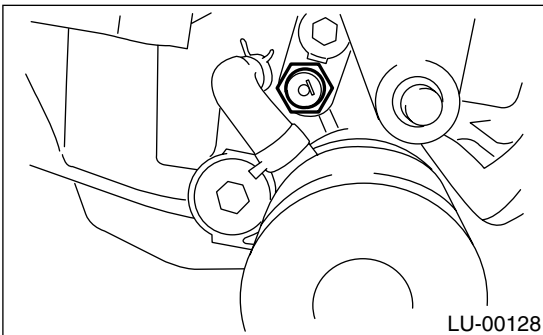

### B: INSTALLATION

- 1) Apply liquid gasket to oil pressure switch threads.

**Liquid gasket:**

**THREE BOND 1324 or equivalent**

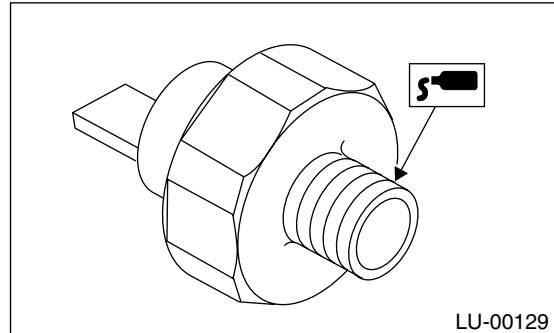

- 2) Install oil pressure switch.

**Tightening torque:**

**25 N·m (2.5 kgf-m, 18.1 ft-lb)**

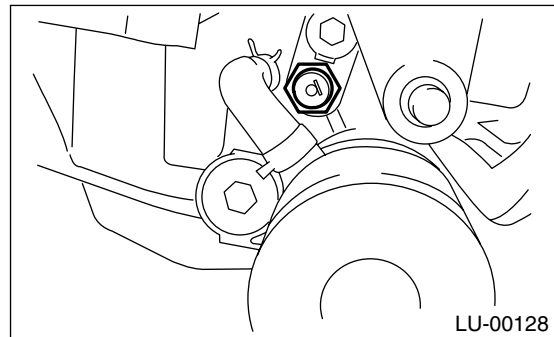

- 3) Connect terminal of oil pressure switch.

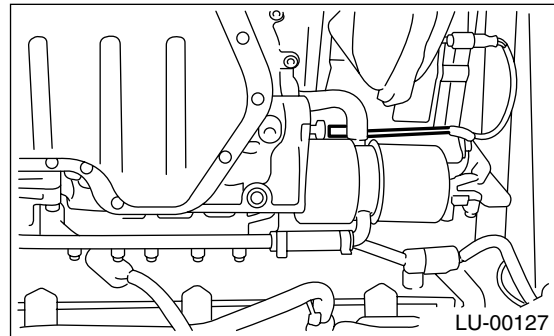

- 4) Install under cover.
- 5) Fill engine oil. <Ref. to LU(H6DO)-10, REPLACEMENT, Engine Oil.>

### C: INSPECTION

Make sure oil does not leak or seep from where the oil pressure switch is installed.

# ENGINE OIL FILTER

## LUBRICATION

### 8. Engine Oil Filter

#### A: REMOVAL

1) Open engine oil filler cap for quick draining of the engine oil.

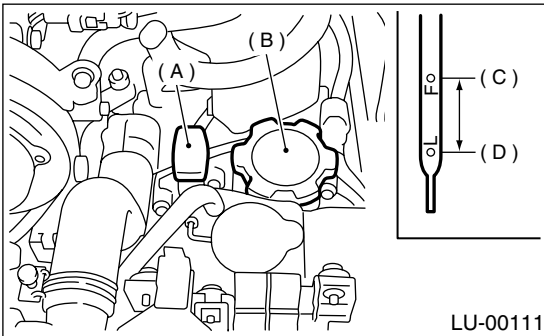

2) Remove access lid.

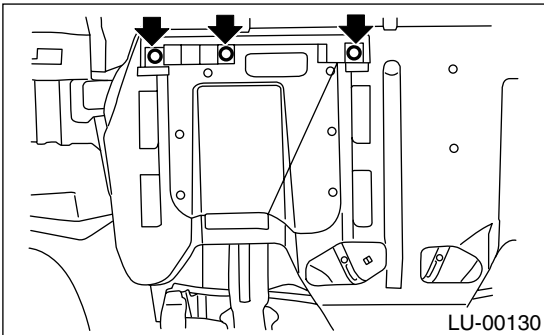

3) Drain engine oil by removing engine oil drain plug.

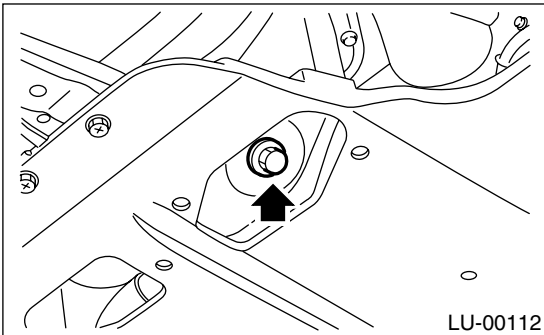

4) Remove oil filter with ST.

ST 498547000 OIL FILTER WRENCH

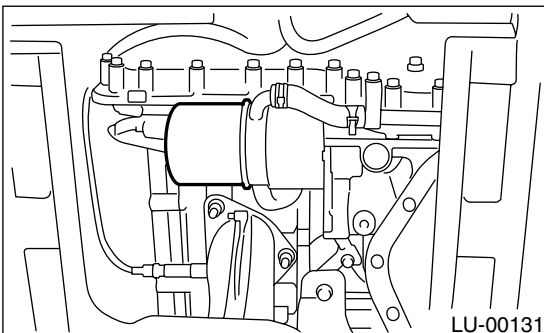

#### B: INSTALLATION

- 1) Get a new oil filter and thinly apply engine oil to the rubber seal.
- 2) Install oil filter by turning it by hand, being careful not to damage rubber seal.
- 3) Tighten more (approximately 3/4 turn) after the rubber seal contacts the oil cooler. Do not tighten excessively, or oil may leak.
- 4) Fill engine oil. <Ref. to LU(H6DO)-10, REPLACEMENT, Engine Oil.>

#### C: INSPECTION

- 1) After installing oil filter, run engine and make sure that no oil is leaking around rubber seal.

#### NOTE:

The filter element and filter case are unified; therefore, interior cleaning is not necessary.

- 2) Check the engine oil level. <Ref. to LU(H6DO)-10, INSPECTION, Engine Oil.>

## 9. Oil Cooler

### A: REMOVAL

- 1) Lift-up the vehicle.
- 2) Remove under cover.

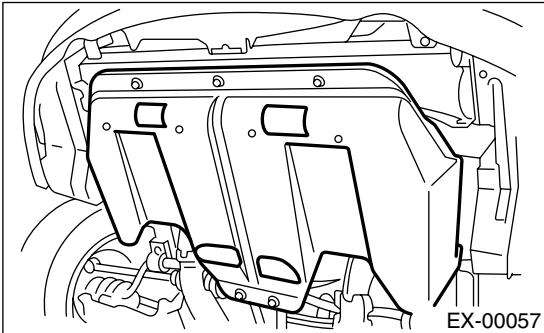

- 3) Drain engine coolant completely. <Ref. to CO(H6DO)-18, DRAINING OF ENGINE COOLANT, REPLACEMENT, Engine Coolant.>
- 4) Drain engine oil. <Ref. to LU(H6DO)-10, REPLACEMENT, Engine Oil.>
- 5) Remove bolts which installs water pipe to engine.

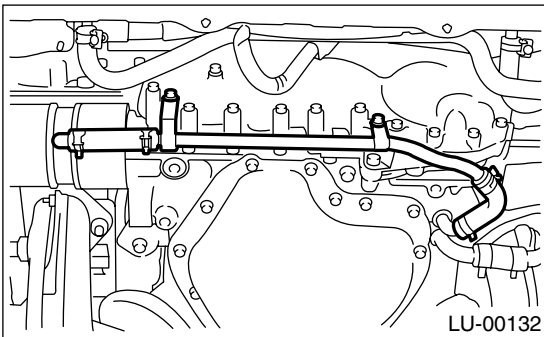

- 6) Disconnect water hoses from oil cooler.

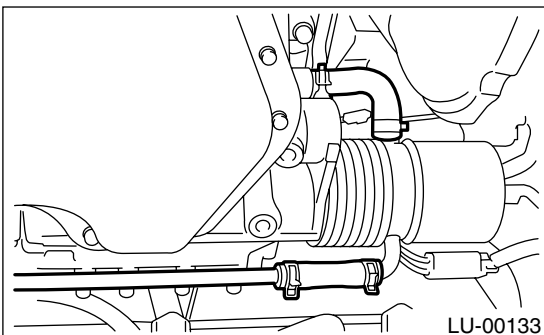

- 7) Remove oil filter using ST. <Ref. to LU(H6DO)-18, REMOVAL, Engine Oil Filter.>

ST 498547000 OIL FILTER WRENCH

#### NOTE:

Set container under the vehicle.

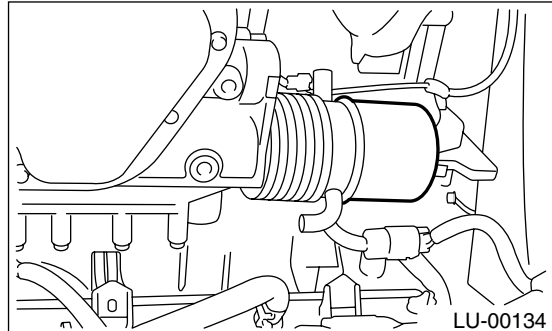

- 8) Remove connector and remove oil cooler.

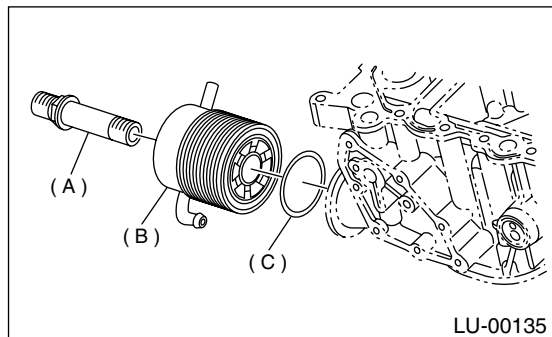

- (A) Connector
- (B) Oil cooler
- (C) O-ring

### B: INSPECTION

- 1) Check that coolant passages are not clogged using air blow method.
- 2) Check upper oil pan and the installation surface of oil filter O-ring for damage.

# OIL COOLER

## LUBRICATION

### C: INSTALLATION

1) Install oil cooler on upper oil pan with connector pipe.

**Tightening torque:**

**T: 54 N·m (5.5 kgf-m, 39.8 ft-lb)**

**NOTE:**

Always use a new O-ring.

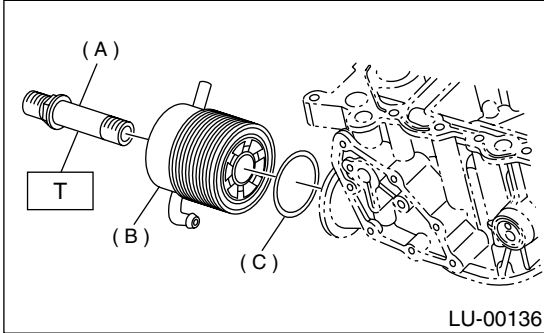

- (A) Connector
- (B) Oil cooler
- (C) O-ring

2) Install oil filter using ST. <Ref. to LU(H6DO)-18, INSTALLATION, Engine Oil Filter.>

ST 498547000 OIL FILTER WRENCH

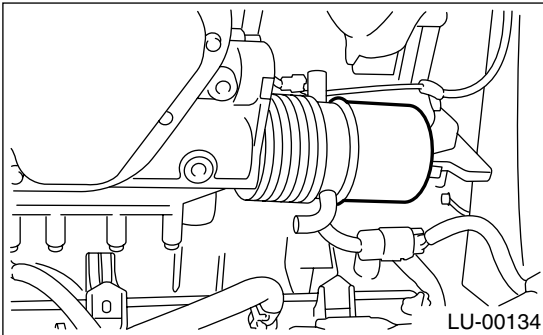

3) Install water hose.

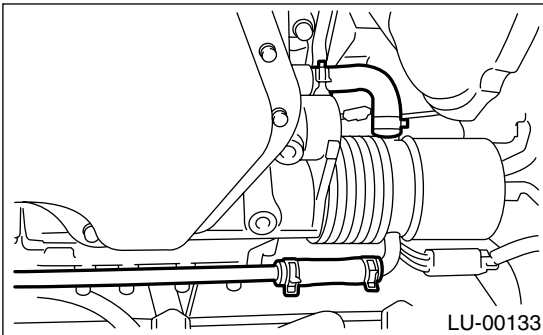

4) Install water pipe to engine.

**Tightening torque:**

**6.4 N·m (0.65 kgf-m, 4.7 ft-lb)**

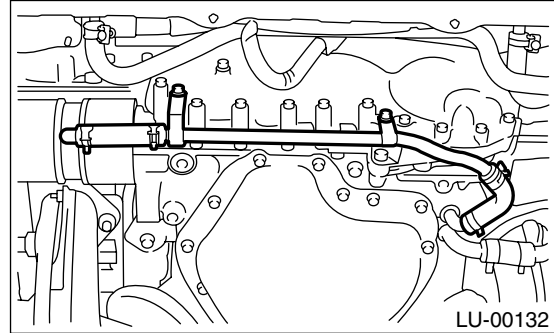

5) Fill engine oil. <Ref. to LU(H6DO)-10, REPLACEMENT, Engine Oil.>

6) Fill engine coolant. <Ref. to CO(H6DO)-18, FILLING OF ENGINE COOLANT, REPLACEMENT, Engine Coolant.>

7) Check the engine oil level. <Ref. to LU(H6DO)-10, INSPECTION, Engine Oil.>

## 10.Engine Lubrication System Trouble in General

### A: INSPECTION

Before performing diagnostics, make sure that the engine oil level is correct and no oil leakage exists.

Trouble	Possible cause		Corrective action
1. Warning light remains ON.	1) Oil pressure switch failure	Cracked diaphragm or pressure leakage within switch	Replace.
		Broken spring or seized contacts	Replace.
	2) Low oil pressure	Clogged oil filter	Replace.
		Malfunction of oil by-pass valve of oil filter	Clean or replace.
		Malfunction of oil relief valve of oil pump	Clean or replace.
		Clogged oil passage	Clean.
		Tip clearance and side clearance of oil pump rotor and gear	Replace.
		Clogged oil strainer or broken pipe	Clean or replace.
	3) No oil pressure	Insufficient engine oil	Replenish.
		Broken pipe of oil strainer	Replace.
Oil pump rotor does not rotate.		Replace.	
2. Warning light does not go on.	1) Broken line related to bulb		Replace.
	2) Poor contact of switch contact points		Replace.
	3) Disconnection of wiring		Repair.
3. Warning light flickers momentarily.	1) Poor contact at terminals		Repair.
	2) Defective wiring harness		Repair.
	3) Low oil pressure		Check for the same possible causes as listed in 1.—2).

# ENGINE LUBRICATION SYSTEM TROUBLE IN GENERAL

LUBRICATION

---

**MEMO:**