

BRAKE

BR

| | Page |
|------------------------------------|-------------|
| 1. General Description | 2 |
| 2. Front Brake Pad | 13 |
| 3. Front Disc Rotor | 15 |
| 4. Front Disc Brake Assembly | 16 |
| 5. Rear Brake Pad | 19 |
| 6. Rear Disc Rotor | 20 |
| 7. Rear Disc Brake Assembly | 22 |
| 8. Master Cylinder | 25 |
| 9. Brake Booster | 27 |
| 10. Proportioning Valve | 31 |
| 11. Brake Fluid | 32 |
| 12. Air Bleeding | 34 |
| 13. Brake Hose | 36 |
| 14. Brake Pipe | 38 |
| 15. Brake Pedal | 39 |
| 16. Stop Light Switch | 42 |
| 17. General Diagnostics | 44 |



GENERAL DESCRIPTION

BRAKE

1. General Description

A: SPECIFICATIONS

| | Size | 15 inch type | | 16 inch type | |
|--|--|---|----------------------|--|------------------|
| | | | | Non-TURBO | With TURBO model |
| Front disc brake | Type | Disc (Floating type, ventilated) | | | |
| | Effective disc diameter | 228 mm (8.98 in) | | 244 mm (9.76 in) | |
| | Disc thickness × Outer diameter | 24 × 277 mm (0.94 × 10.91 in) | | 24 × 294 mm (0.94 × 11.57 in) | |
| | Effective cylinder diameter | 42.8 mm (1.685 in) × 2 | | | |
| | Pad dimensions (length × width × thickness) | 117.8 × 50.5 × 11.0 mm (4.638 × 1.988 × 0.433 in) | | | |
| | Clearance adjustment | Automatic adjustment | | | |
| | Rear disc brake | Type | Disc (Floating type) | | |
| Effective disc diameter | | 254 mm (10.0 in) | | | |
| Disc thickness × Outer diameter | | 10 × 290 mm (0.39 × 11.42 in) | | | |
| Effective cylinder diameter | | 38.1 mm (1.500 in) | | | |
| Pad dimensions (length × width × thickness) | | 82.4 × 33.7 × 9.0 mm (3.244 × 1.327 × 0.354 in) | | | |
| Clearance adjustment | | Automatic adjustment | | | |
| Master cylinder | Type | Tandem | | | |
| | Effective diameter | 26.99 mm (17/16 in) | | 25.4 mm (1 in) | |
| | Reservoir type | Sealed type | | | |
| | Brake fluid reservoir capacity | 205 cm ³ (12.51 cu in) | | | |
| Brake booster | Type | Vacuum suspended | | | |
| | Effective diameter | 205 + 230 mm (8.07 + 9.06 in) | | | |
| Proportioning valve | Split point | 2,942 kPa (30 kg/cm ² , 427 psi) | | 3,678 kPa (without VDC) (37.5 kg/cm ² , 533 psi) 2,942 kPa (without VDC) (30 kg/cm ² , 427 psi) | |
| | Reducing ratio | 0.3 | | | |
| Brake line | Dual circuit system | | | | |
| Brake fluid | FMVSS No. 116, DOT3 or DOT4 | | | | |
| CAUTION: <ul style="list-style-type: none"> • Avoid mixing brake fluid of different brands to prevent the fluid performance from degrading. • When brake fluid is supplemented, be careful not to allow any dust into the reservoir. • Use fresh DOT3 or 4 brake fluid when replacing or refilling the fluid. | | | | | |

NOTE:

Refer to "PB section" for parking brake SPECIFICATIONS.

GENERAL DESCRIPTION

BRAKE

| ITEM | | STANDARD | SERVICE LIMIT |
|---------------|--------------------------------------|--------------------------------------|----------------------|
| Front brake | Pad thickness (including back metal) | 17 mm (0.67 in) | 7.5 mm (0.295 in) |
| | Disc thickness | 24 mm (0.94 in) | 22 mm (0.87 in) |
| | Disc runout | — | 0.075 mm (0.0030 in) |
| Rear brake | Pad thickness (including back metal) | 14 mm (0.55 in) | 6.5 mm (0.256 in) |
| | Disc thickness | 10 mm (0.39 in) | 8.5 mm (0.335 in) |
| | Disc runout | — | 0.070 mm (0.0028 in) |
| Parking brake | Inside diameter | 170 mm (6.69 in) | 171 mm (6.73 in) |
| | Lining thickness | 3.2 mm (0.126 in) | 1.5 mm (0.059 in) |
| | Lever stroke | 7 to 8 notches/196 N (20 kgf, 44 lb) | |

| | | Brake pedal force | Fluid pressure | |
|---------------|--|-----------------------|---|--------------|
| | | | 15 inch type | 16 inch type |
| Brake booster | Brake fluid pressure without engine running | 147 N (15 kgf, 33 lb) | 588 kPa (6 kg/cm ² , 85 psi) | |
| | | 294 N (30 kgf, 66 lb) | 1,569 kPa (16 kg/cm ² , 228 psi) | |
| | Brake fluid pressure with engine running and vacuum at 66.7 kPa (500 mmHg, 19.69 inHg) | 147 N (15 kgf, 33 lb) | 6,178 kPa (63 kg/cm ² , 896 psi) | |
| | | 294 N (30 kgf, 66 lb) | 9,709 kPa (99 kg/cm ² , 1,408 psi) | |

| | | |
|-------------|-----------|--|
| Brake pedal | Free play | 1 — 3 mm (0.04 — 0.12 in) [Depress brake pedal pad with a force of less than 10 N (1 kgf, 2 lb).] |
|-------------|-----------|--|

2. REAR DISC BRAKE

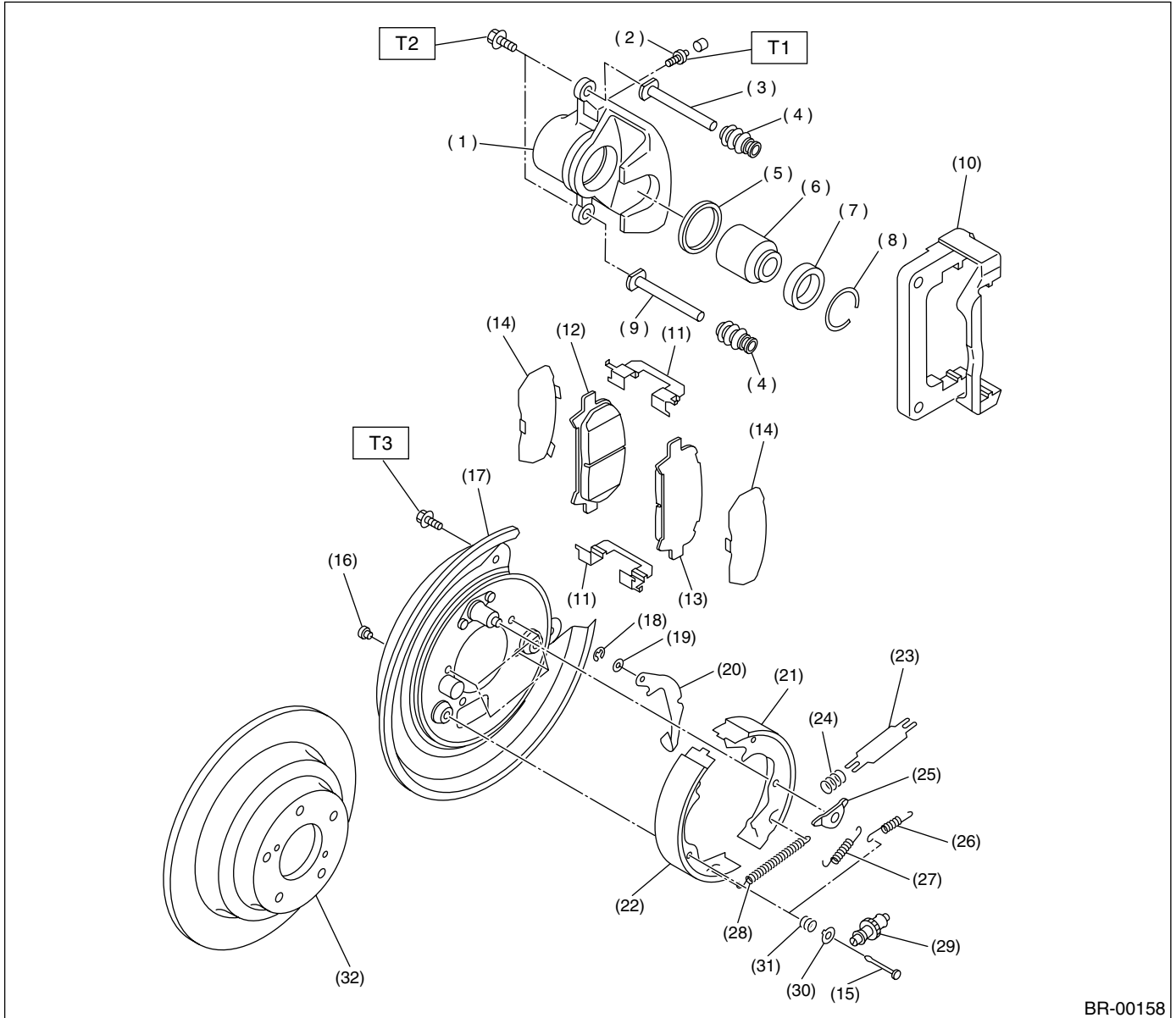

BR-00158

- | | | |
|---|--|---|
| <ul style="list-style-type: none"> (1) Caliper body (2) Air bleeder screw (3) Guide pin (Green) (4) Pin boot (5) Piston seal (6) Piston (7) Piston boot (8) Boot ring (9) Lock pin (Yellow) (10) Support (11) Pad clip (12) Inner pad (13) Outer pad | <ul style="list-style-type: none"> (14) Shim (15) Shoe hold-down pin (16) Cover (17) Back plate (18) Retainer (19) Spring washer (20) Parking brake lever (21) Parking brake shoe (Secondary) (22) Parking brake shoe (Primary) (23) Strut (24) Strut shoe spring (25) Shoe guide plate (26) Secondary shoe return spring | <ul style="list-style-type: none"> (27) Primary shoe return spring (28) Adjusting spring (29) Adjuster (30) Shoe hold-down cup (31) Shoe hold-down spring (32) Disc rotor |
|---|--|---|

Tightening torque: N·m (kgf·m, ft·lb)

T1: 8 (0.8, 5.8)

T2: 39 (4.0, 28.9)

T3: 52 (5.3, 38.3)

GENERAL DESCRIPTION

BRAKE

3. MASTER CYLINDER

• Models without VDC

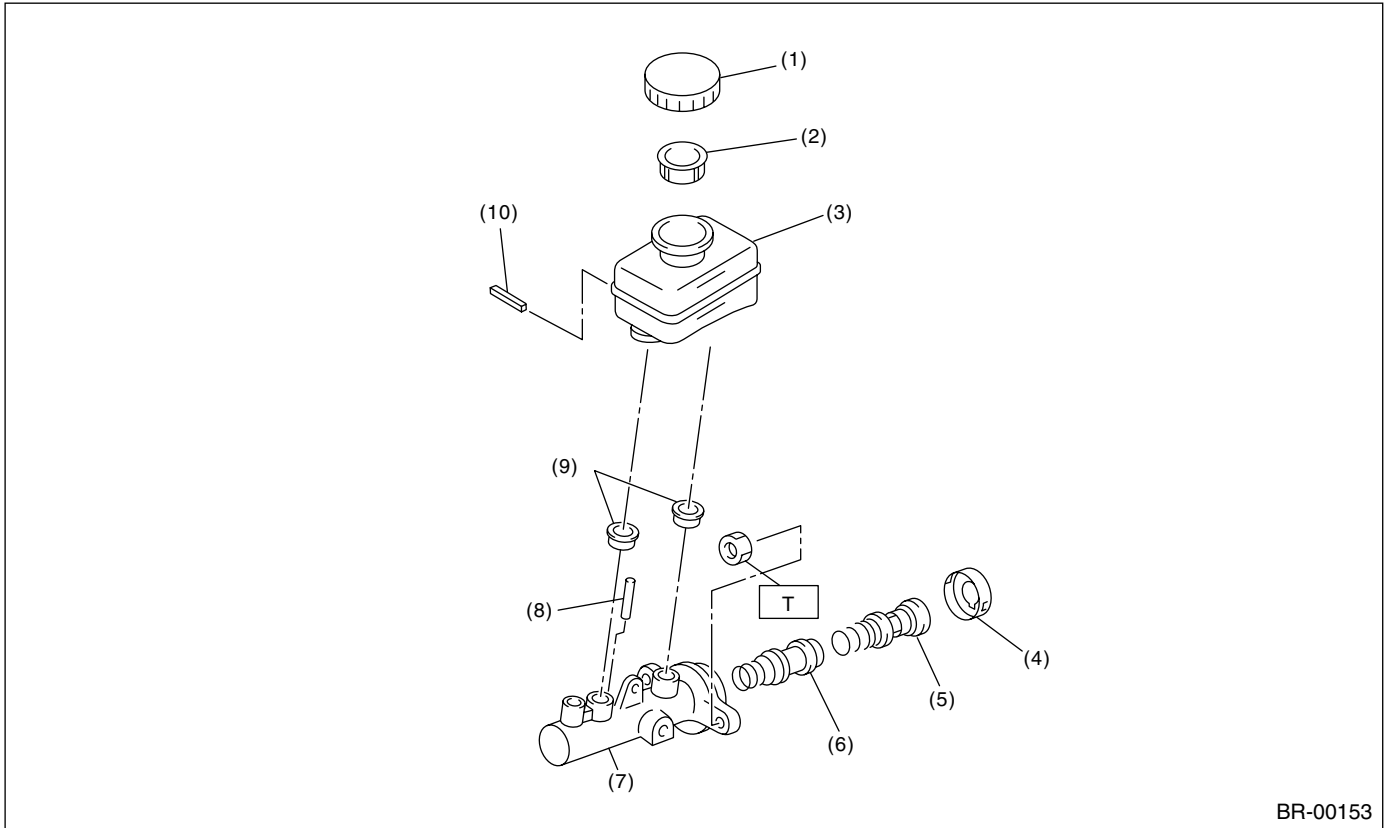

BR-00153

- | | |
|---------------------|-----------------------------|
| (1) Cap | (6) Secondary piston |
| (2) Filter | (7) Cylinder body |
| (3) Reservoir tank | (8) Cylinder pin (With ABS) |
| (4) Piston retainer | (9) Seal |
| (5) Primary piston | (10) Pin |

Tightening torque: N·m (kgf-m, ft-lb)

T: 14 (1.4, 10.1)

GENERAL DESCRIPTION

BRAKE

• Model with VDC

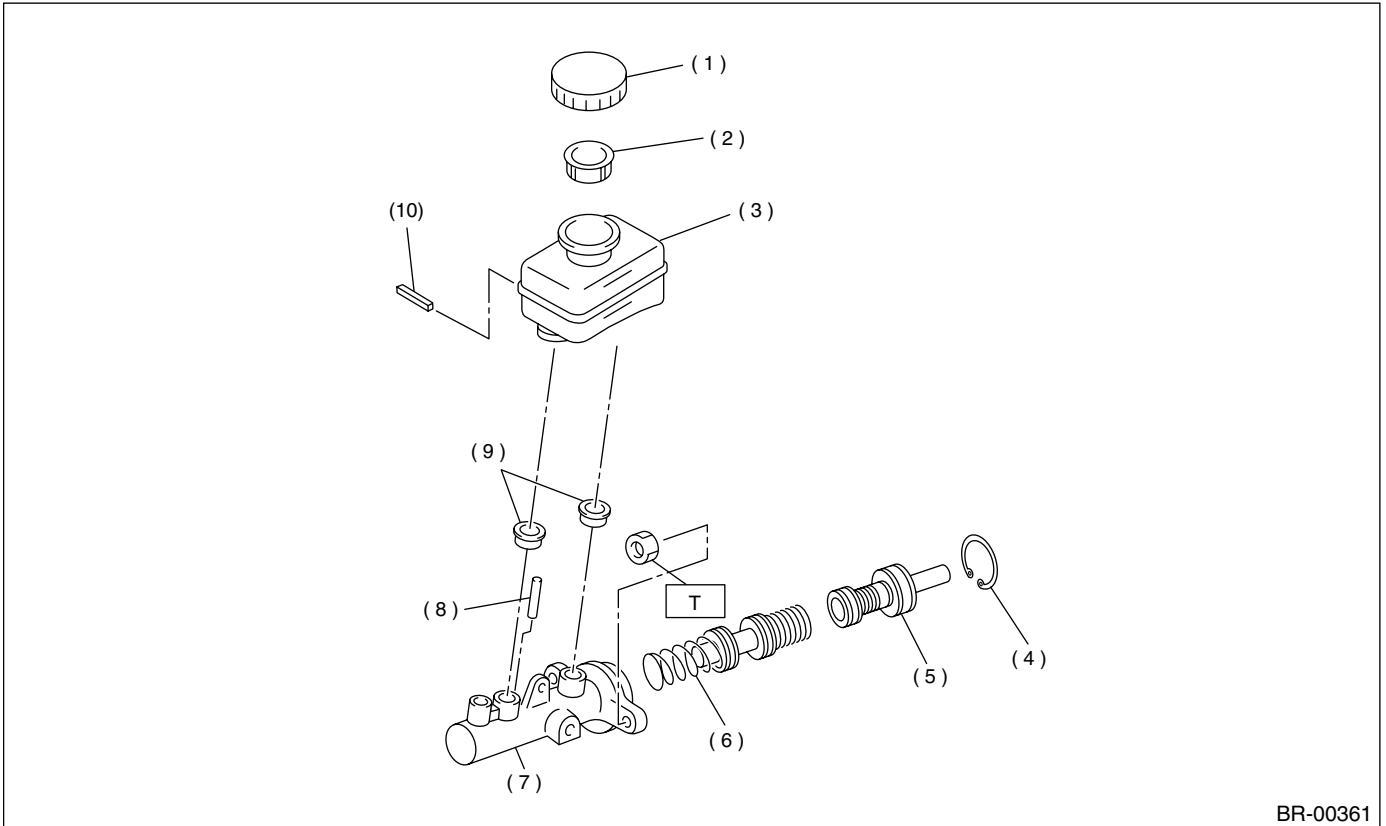

BR-00361

- | | |
|--------------------|----------------------|
| (1) Cap | (6) Secondary piston |
| (2) Filter | (7) Cylinder body |
| (3) Reservoir tank | (8) Cylinder pin |
| (4) C-ring | (9) Seal |
| (5) Primary piston | (10) Pin |

Tightening torque: N·m (kgf·m, ft·lb)

T: 14 (1.4, 10.1)

GENERAL DESCRIPTION

BRAKE

4. BRAKE PIPES AND HOSE

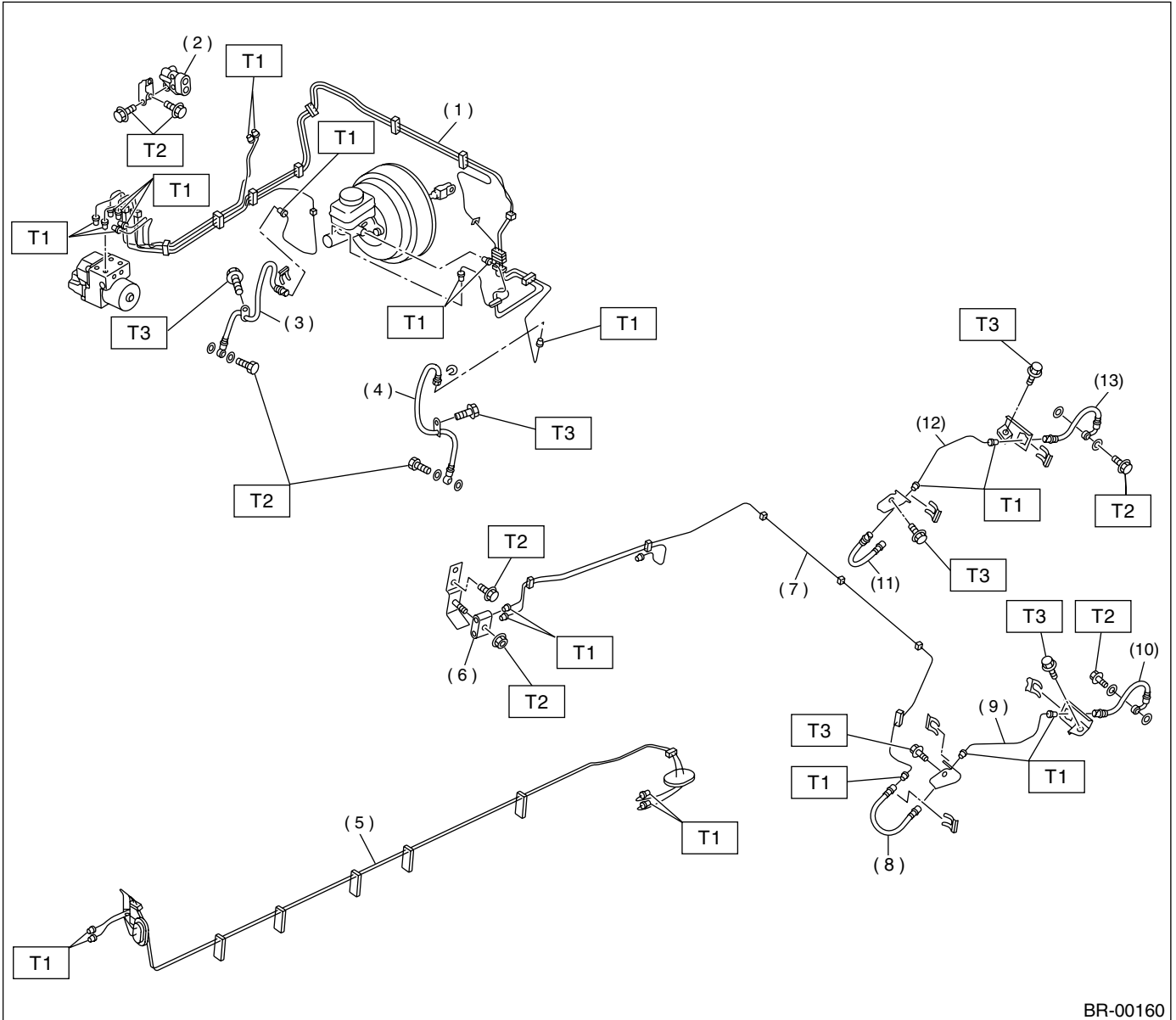

BR-00160

- | | |
|--------------------------------|------------------------------|
| (1) Front brake pipe assembly | (7) Rear brake pipe assembly |
| (2) Proportioning valve | (8) Rear brake hose LH |
| (3) Front brake hose RH | (9) Rear brake pipe LH |
| (4) Front brake hose LH | (10) Rear brake hose rear LH |
| (5) Center brake pipe assembly | (11) Rear brake hose RH |
| (6) Two-way connector | (12) Rear brake pipe RH |

- | |
|------------------------------|
| (13) Rear brake hose rear RH |
|------------------------------|

Tightening torque: N·m (kgf·m, ft·lb)

T1: 15 (1.5, 10.8)

T2: 18 (1.8, 13.0)

T3: 33 (3.3, 23.8)

5. BRAKE BOOSTER

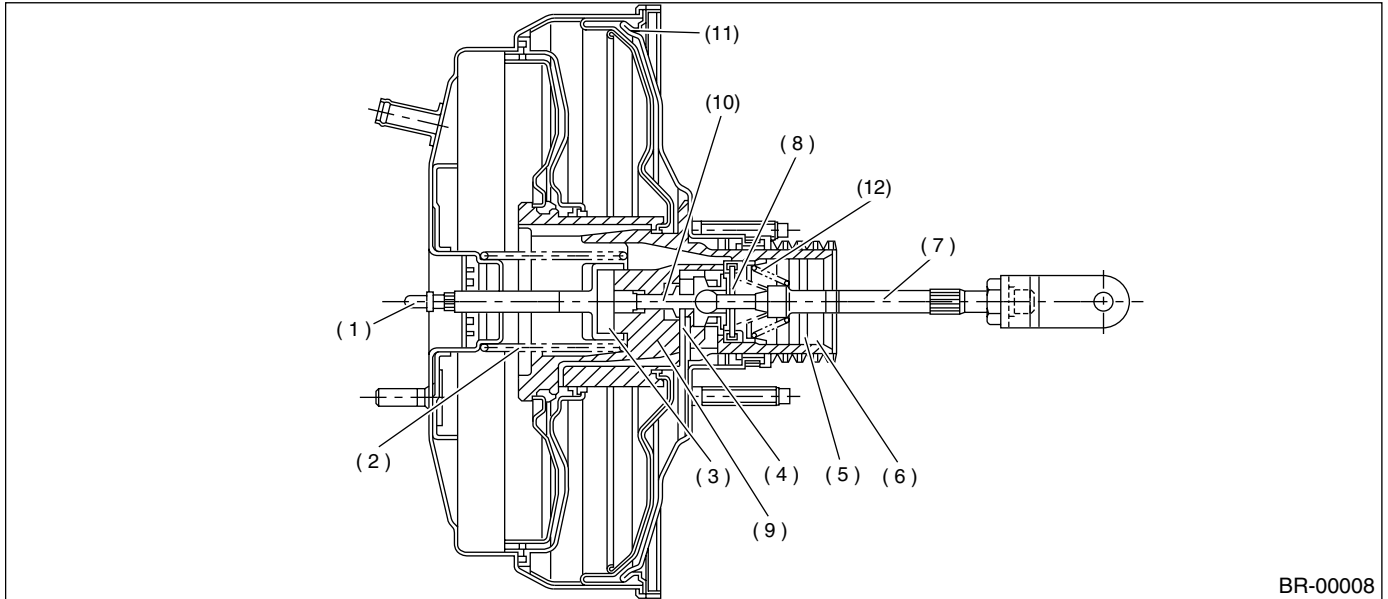

BR-00008

- | | | |
|-------------------|-------------------|--------------------------|
| (1) Push rod | (5) Filter | (9) Valve body |
| (2) Return spring | (6) Silencer | (10) Plunger valve |
| (3) Reaction disc | (7) Operating rod | (11) Diaphragm plate |
| (4) Key | (8) Poppet valve | (12) Valve return spring |

GENERAL DESCRIPTION

BRAKE

6. BRAKE PEDAL FOR MT MODEL

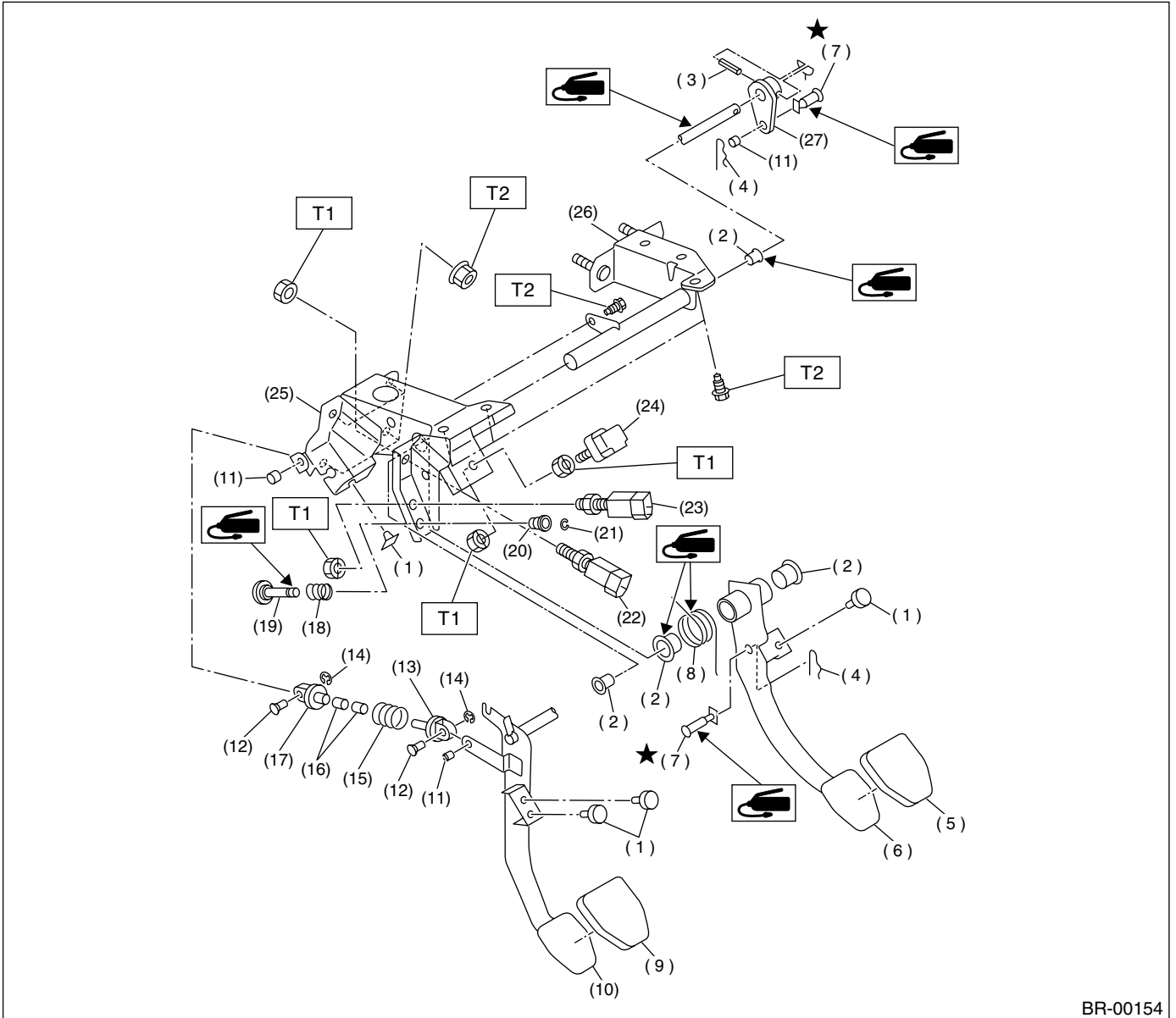

BR-00154

- | | | |
|------------------------|--|--|
| (1) Stopper | (12) Clutch clevis pin | (23) Clutch switch (With cruise control) |
| (2) Bushing | (13) Assist rod A | (24) Stop light switch |
| (3) Spring pin | (14) Clip | (25) Pedal bracket |
| (4) Snap pin | (15) Assist spring | (26) Clutch master cylinder bracket |
| (5) Brake pedal pad | (16) Assist bushing | (27) Lever |
| (6) Brake pedal | (17) Assist rod B | |
| (7) Clevis pin | (18) Spring S | |
| (8) Brake pedal spring | (19) Rod S | |
| (9) Clutch pedal pad | (20) Bushing S | |
| (10) Clutch pedal | (21) Clip | |
| (11) Bushing C | (22) Clutch switch (Starter interlock) | |

Tightening torque: N·m (kgf·m, ft·lb)

T1: 8 (0.8, 5.8)

T2: 18 (1.8, 13.0)

7. BRAKE PEDAL FOR AT MODEL

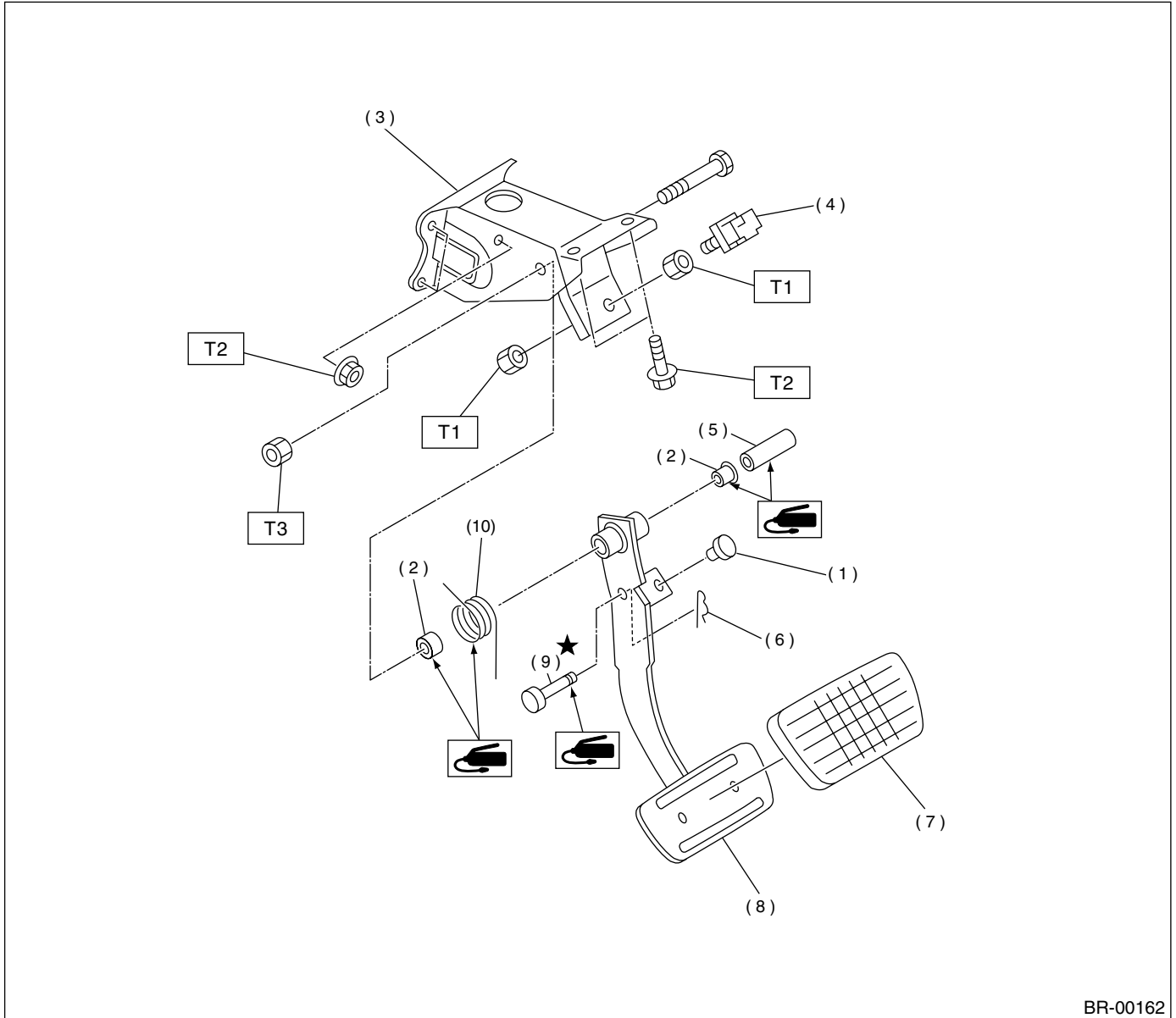

BR-00162

- | | |
|-----------------------|-------------------------|
| (1) Stopper | (7) Brake pedal pad |
| (2) Bushing | (8) Brake pedal |
| (3) Pedal bracket | (9) Clevis pin |
| (4) Stop light switch | (10) Brake pedal spring |
| (5) Spacer | |
| (6) Snap pin | |

Tightening torque: N·m (kgf-m, ft-lb)

T1: 8 (0.8, 5.8)

T2: 18 (1.8, 13.0)

T3: 29 (3.0, 21.7)

GENERAL DESCRIPTION

BRAKE

C: CAUTION

- Wear working clothing, including a cap, protective goggles, and protective shoes during operation.
- Remove contamination including dirt and corrosion before removal, installation or disassembly.
- Keep the disassembled parts in order and protect them from dust or dirt
- Before removal, installation or disassembly, be sure to clarify the failure. Avoid unnecessary removal, installation, disassembly, and replacement.
- Be careful not to burn your hands, because each part in the vehicle is hot after running.
- Use SUBARU genuine grease etc. or the equivalent. Do not mix grease etc. with that of another grade or from other manufacturers.
- Be sure to tighten fasteners including bolts and nuts to the specified torque.
- Place shop jacks or safety stands at the specified points.
- Apply grease onto sliding or revolving surfaces before installation.
- Before installing O-rings or snap rings, apply sufficient amount of grease to avoid damage and deformation
- Before securing a part on a vise, place cushioning material such as wood blocks, aluminum plate, or shop cloth between the part and the vise.
- Do not put fluid on body. If the body is tainted, wash away with water.

D: PREPARATION TOOL

1. GENERAL PURPOSE TOOLS

| TOOL NAME | REMARKS |
|------------------|---|
| Snap Ring Pliers | Used for removing and installing snap ring. |

2. Front Brake Pad

A: REMOVAL

- 1) Loosen wheel nuts, jack-up vehicle, support it with safety stands, and remove wheel.
- 2) Remove bottom bolt.
- 3) Raise caliper body and suspend it securely.

NOTE:

Do not disconnect brake hose from caliper body.

- 4) Remove pad.

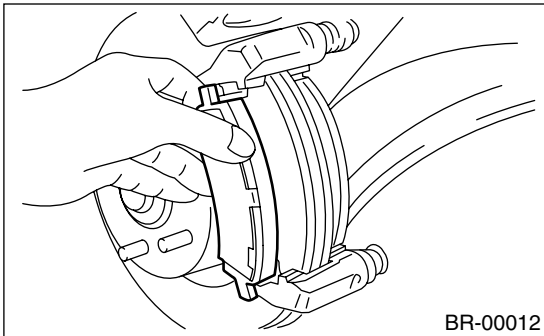

NOTE:

If brake pad is difficult to remove, proceed as follows:

- (1) Remove caliper body and fasten it provisionally to coil spring.
- (2) Remove support.
- (3) Place a support in a vise between wooden blocks.

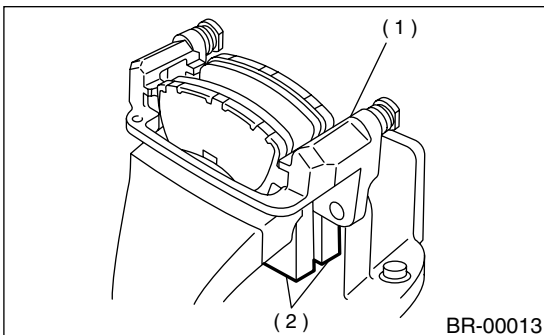

- (1) Support
- (2) Wooden blocks

- (4) Attach a rod of less than 12 mm (0.47 in) dia. to the shaded area of brake pad, and strike the rod with a hammer to drive brake pad out of place.

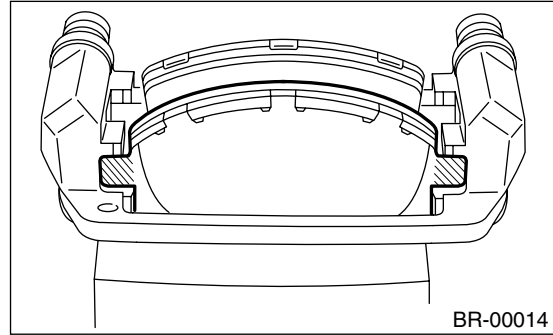

B: INSTALLATION

- 1) Apply thin coat of Molykote AS880N (Part No. 26298AC000) to the frictional portion between pad and pad clip.
- 2) Apply thin coat of Molykote AS880N (Part No. 26298AC000) to the frictional portion between pad and pad inner shim.

CAUTION:

Do not allow oil or grease to adhere to the sliding surface of pad and disc rotor.

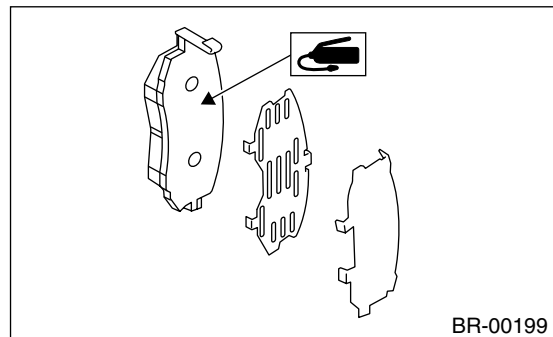

- 3) Check disc rotor thickness and runout. <Ref. to BR-15, INSPECTION, Front Disc Rotor.>
- 4) Install pads on support.
- 5) Install caliper body on support.

Tightening torque:

39 N·m (4.0 kgf·m, 28.9 ft·lb)

NOTE:

If it is difficult to push piston during pad replacement, loosen air bleeder to facilitate work.

- 6) Depress brake pedal several times.
- 7) Check that brake fluid level is at max. line.

FRONT BRAKE PAD

BRAKE

C: INSPECTION

Check pad thickness A.

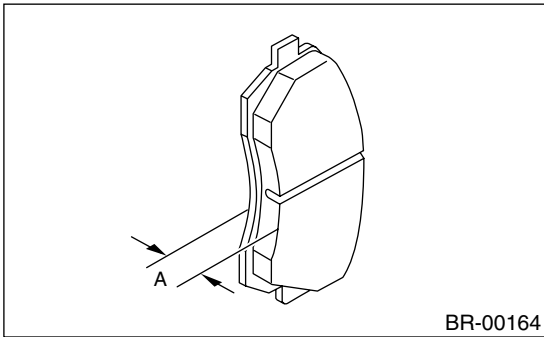

| | | |
|--|----------------|-------------------|
| Pad thickness (including back metal) | Standard value | 17 mm (0.67 in) |
| | Wear limit | 7.5 mm (0.295 in) |

CAUTION:

- Always replace the pads for both the left and right wheels at the same time. Also replace pad clips if they are twisted or worn.
- A wear indicator is provided on the inner disc brake pad. If the pad wears down to such an extent that the end of the wear indicator contacts the disc rotor, a squeaking sound is produced as the wheel rotates. If this sound is heard, replace the pad.
- Replace pad if there is oil or grease on it.

3. Front Disc Rotor

A: REMOVAL

- 1) Loosen wheel nuts, jack-up vehicle, support it with safety stands, and remove wheel.
- 2) Remove caliper body from housing, and suspend it from strut using a wire.

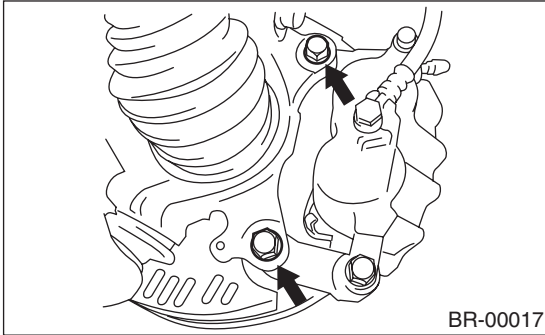

- 3) Remove the disc rotor.

NOTE:

If disc rotor seizes up within the hub, drive disc rotor out by installing an 8-mm bolt in holes B on the rotor.

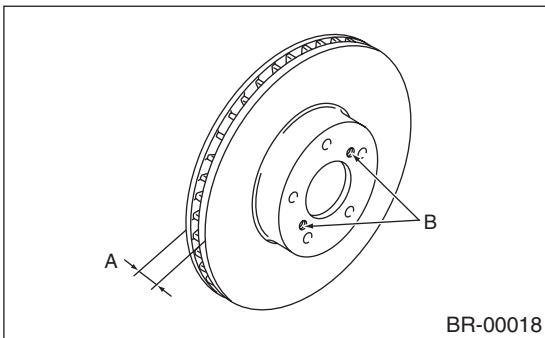

- 4) Clean mud and foreign particles from caliper body assembly and support.

B: INSTALLATION

- 1) Install the disc rotor.
- 2) Install the caliper body to housing.

Tightening torque:

78 N·m (8 kgf·m, 58 ft·lb)

C: INSPECTION

- 1) Secure disc rotor by tightening the five wheel nuts.
- 2) Set a dial gauge on the disc rotor. Turn disc rotor to check runout.

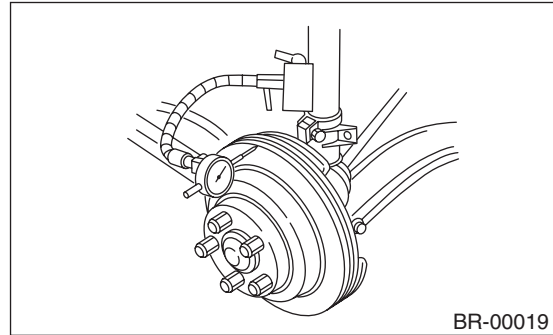

NOTE:

- Make sure that dial gauge is set 10 mm (0.39 in) inward of rotor outer perimeter.
- If disc rotor runout is above standard value, inspect play of hub bearing axial direction and runout of axle hub.

<Ref. to DS-23, INSPECTION, Front Axle.>

If bearing and hub are normal, resurface the disc rotor. After resurfacing, check disc rotor thickness as in step 3.

Disc rotor runout limit:

0.075 mm (0.0030 in)

- 3) Measure disc rotor thickness.

If thickness of disc rotor is below service limit, replace disc rotor.

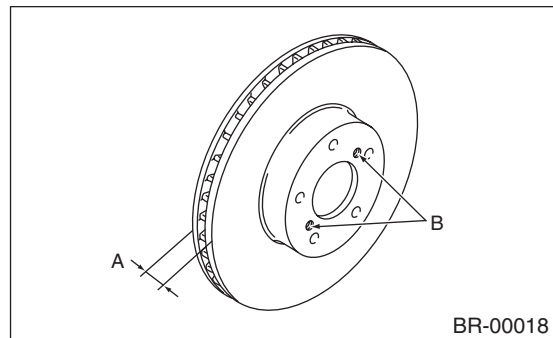

NOTE:

Make sure that micrometer is set 10 mm (0.39 in) inward of rotor outer perimeter.

| | | Standard value | Service limit | Disc outer dia. |
|------------------------|-----|--------------------|--------------------|-------------------|
| Disc rotor thickness A | 15" | 24.0 mm (0.945 in) | 22.0 mm (0.866 in) | 277 mm (10.91 in) |
| | 16" | 24.0 mm (0.945 in) | 22.0 mm (0.866 in) | 294 mm (11.57 in) |

FRONT DISC BRAKE ASSEMBLY

BRAKE

4. Front Disc Brake Assembly

A: REMOVAL

- 1) Loosen wheel nuts, jack-up vehicle, support it with safety stands, and remove wheel.
- 2) Remove union bolt and disconnect brake hose from caliper body assembly.

CAUTION:

Do not spill brake fluid on painted surface.
Wash it off immediately.

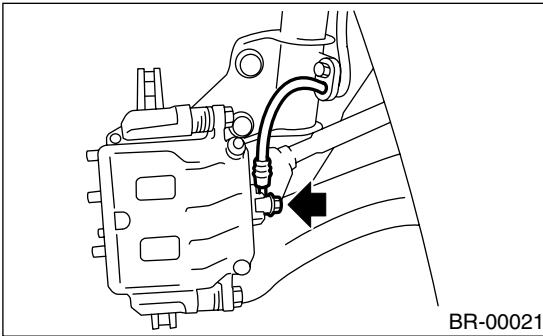

- 3) Remove bolt securing lock pin to caliper body.

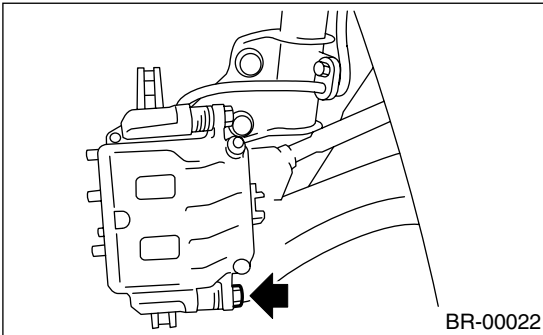

- 4) Raise caliper body and move it toward vehicle center to separate it from support.
- 5) Remove support from housing.

NOTE:

Remove support only when replacing it or the rotor. It need not be removed when servicing caliper body assembly.

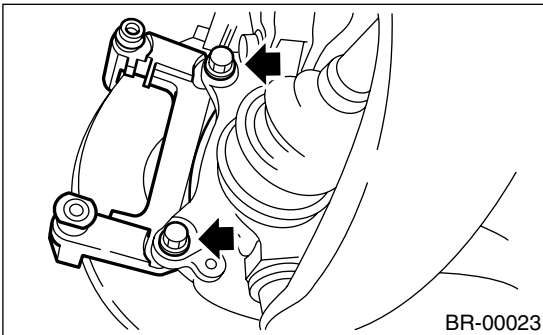

- 6) Remove disc rotor from hub.

NOTE:

If disc rotor seizes up within hub, drive disc rotor out by installing an 8-mm bolt in holes B on the rotor.

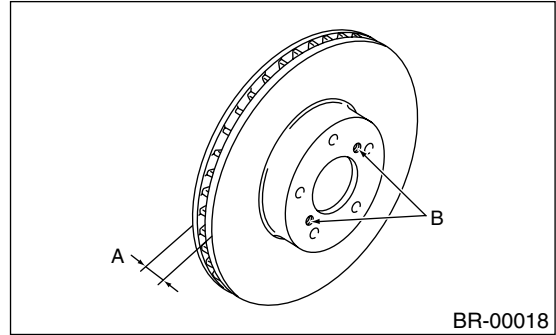

- 7) Clean mud and foreign particles from caliper body assembly and support.

B: INSTALLATION

- 1) Install disc rotor on hub.
- 2) Install support on housing.

Tightening torque:

78 N·m (8 kgf·m, 58 ft·lb)

CAUTION:

- Always replace the pads for both the left and right wheels at the same time. Also replace pad clips if they are twisted or worn.
- A wear indicator is provided on the inner disc brake pad. If the pad wears down to such an extent that the end of the wear indicator contacts the disc rotor, a squeaking sound is produced as the wheel rotates. If this sound is heard, replace the pad.
- When replacing the pads, replace pads of the right and left wheels at the same time.

- 3) Apply thin coat of Molykote AS880N (Part No. 26298AC000) to the frictional portion between pad and pad clip.

- 4) Apply thin coat of Molykote AS880N (Part No. 26298AC000) to the frictional portion between pad and inner shim.

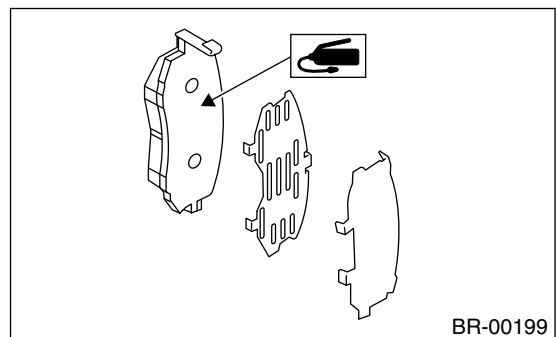

- 5) Install pads on support.

6) Install caliper body on support.

Tightening torque:

39 N·m (4.0 kgf-m, 28.9 ft-lb)

7) Connect brake hose.

Tightening torque:

18 N·m (1.8 kgf-m, 13.0 ft-lb)

CAUTION:

Replace brake hose gaskets with new ones.

8) Bleed air from brake system.

C: DISASSEMBLY

1) Clean mud and foreign particles from the caliper body assembly and support.

CAUTION:

Be careful not to allow foreign particles to enter inlet (at brake hose connector).

2) Remove the boot from piston end.

3) Place a wooden block as shown in the figure to prevent damage to the piston. Gradually supply compressed air via inlet of the brake hose to force piston out.

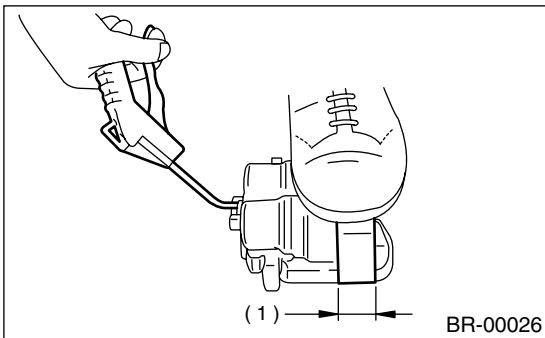

(1) Place a 30 mm (1.18 in) wide wooden block here.

4) Remove the piston seal from caliper body cylinder.

CAUTION:

Be careful not to scratch the inner surface of cylinder and piston seal groove.

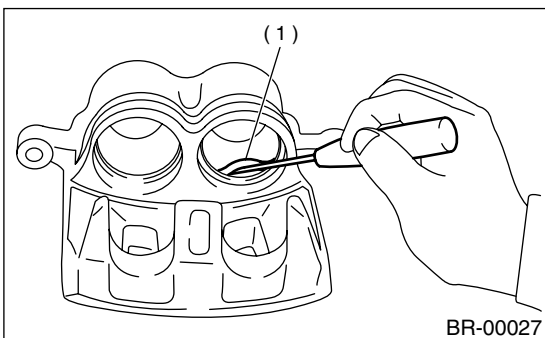

(1) Piston seal

5) Remove the lock pin boot and guide pin boot.

D: ASSEMBLY

1) Clean the caliper body interior using brake fluid.

2) Apply a coat of brake fluid to the piston seal and fit piston seal in groove on caliper body.

3) Apply a coat of brake fluid to the entire inner surface of cylinder and outer surface of piston.

4) Apply a coat of specified grease to the boot and fit in groove on ends of cylinder and piston.

Grease:

NIGLUBE RX-2 (Part No. K0779GA102)

5) Insert the piston into cylinder.

CAUTION:

Do not force the piston into cylinder.

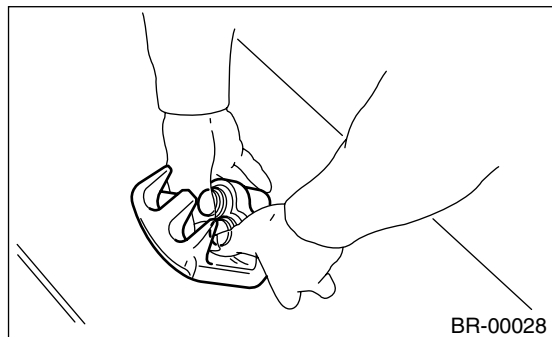

6) Position the boot in grooves on cylinder and piston.

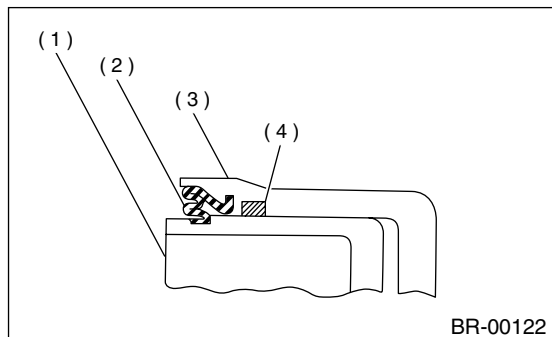

- (1) Piston
- (2) Piston boot
- (3) Caliper body
- (4) Piston seal

FRONT DISC BRAKE ASSEMBLY

BRAKE

7) Apply a coat of specified grease to the lock pin and guide pin, outer surface, cylinder inner surface, and boot grooves.

Grease:

NIGLUBE RX-2 (Part No. K0779GA102)

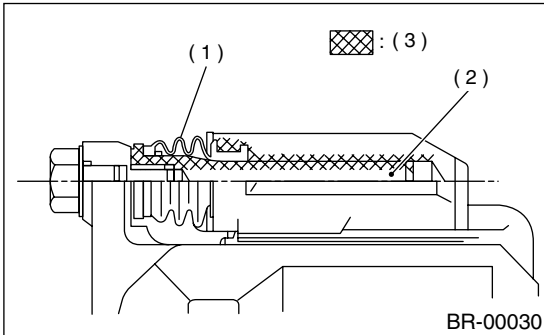

- (1) Pin boot
- (2) Lock pin or guide pin
- (3) Apply grease.

8) Install the lock pin boot and guide pin boot on support.

E: INSPECTION

- 1) Repair or replace the faulty parts.
- 2) Check the caliper body and piston for uneven wear, damage or rust.
- 3) Check the rubber parts for damage or deterioration.

5. Rear Brake Pad

A: REMOVAL

- 1) Loosen wheel nuts, jack-up vehicle, support it with safety stands, and remove wheel.
- 2) Remove bottom bolt.

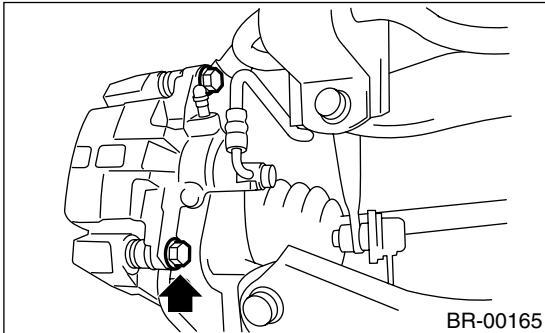

- 3) Raise caliper body and suspend it securely.

NOTE:

Do not disconnect brake hose from caliper body.

- 4) Remove pad from support.

NOTE:

If brake pad is difficult to remove, use the same procedure as for front disc brake pad.

<Ref. to BR-13, REMOVAL, Front Brake Pad.>

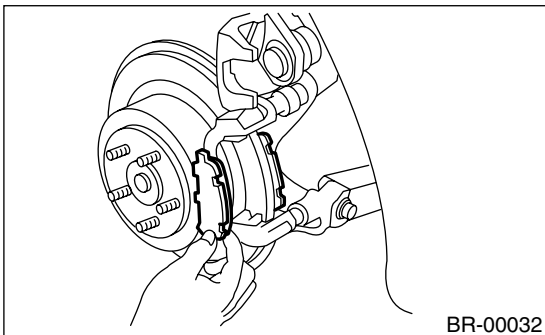

B: INSTALLATION

- 1) Apply thin coat of Molykote AS880N (Part No. 26298AC000) to the frictional portion between pad and pad clip.

CAUTION:

Do not allow oil or grease to adhere to the sliding surface of pad and disc rotor.

- 2) Check disc rotor thickness and runout.
<Ref. to BR-20, INSPECTION, Rear Disc Rotor.>
- 3) Install pad on support.
- 4) Install caliper body on support.

Tightening torque:

39 N·m (4.0 kgf·m, 28.9 ft·lb)

NOTE:

If it is difficult to push piston during pad replacement, loosen air bleeder to facilitate work.

- 5) Depress brake pedal several times.

- 6) Check that brake fluid level is at max. line.

C: INSPECTION

Check pad thickness (including back metal).

Pad thickness: A

Standard value

14.0 mm (0.551 in)

Wear limit

6.5 mm (0.256 in)

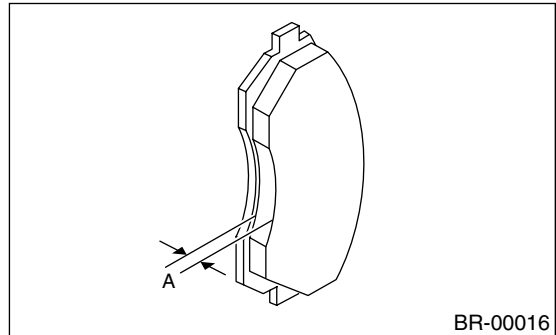

CAUTION:

- Always replace the pads for both the left and right wheels at the same time. Also replace pad clips if they are twisted or worn.
- A wear indicator is provided on the inner disc brake pad. If the pad wears down to such an extent that the end of the wear indicator contacts the disc rotor, a squeaking sound is produced as the wheel rotates. If this sound is heard, replace the pad.
- Replace pad if there is oil or grease on it.

REAR DISC ROTOR

BRAKE

6. Rear Disc Rotor

A: REMOVAL

- 1) Lift-up vehicle and remove wheels.
- 2) Remove the two mounting bolts and remove the disc brake assembly.

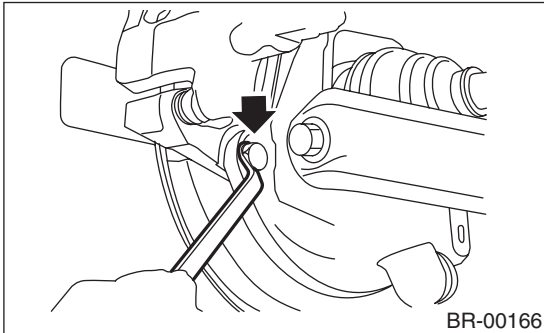

- 3) Suspend the disc brake assembly so that the hose is not stretched.
- 4) Pull down and release parking brake.
- 5) Remove the disc rotor.

NOTE:

If the disc rotor is difficult to remove try the following two methods in order.

- (1) Turn adjusting screw using a slot-type screwdriver until brake shoe gets away enough from the disc rotor.

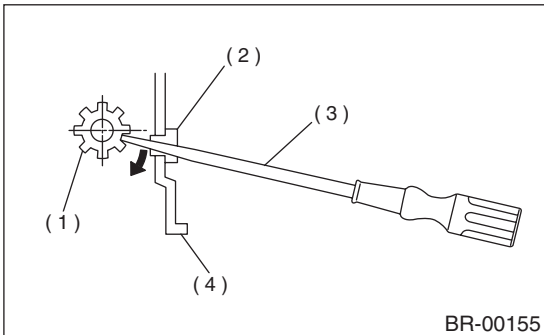

- (1) Adjusting screw
- (2) Cover
- (3) Slot-type screwdriver
- (4) Back plate

- (2) If disc rotor seizes up within hub, drive disc rotor out by installing an 8-mm bolt in holes B on the rotor.

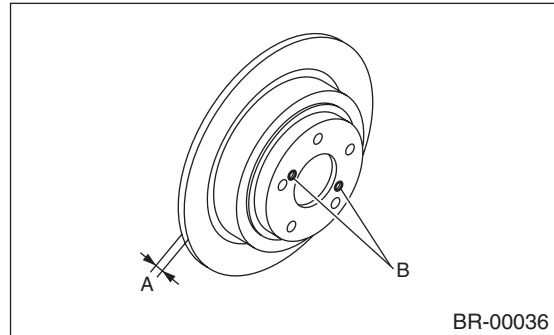

B: INSTALLATION

- 1) Install in the reverse order of removal.
- 2) Adjust parking brake. <Ref. to PB-10, ADJUSTMENT, Parking Brake Assembly.>

C: INSPECTION

- 1) Secure disc rotor by tightening the five wheel nuts.
- 2) Set a dial gauge on the disc rotor. Turn disc rotor to check runout.

CAUTION:

Securely fix disc rotor to hub.

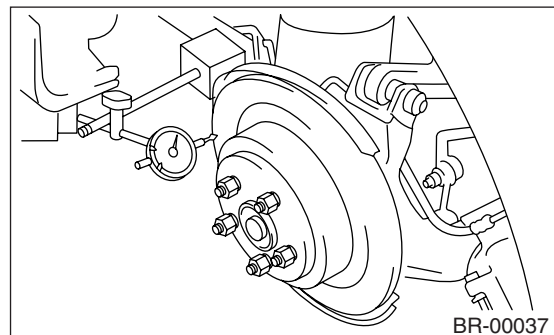

NOTE:

- Make sure that dial gauge is set 10 mm (0.39 in) inward of rotor outer perimeter.
- If disc rotor runout is above standard value, inspect play of hub bearing axial direction and runout of axle hub. <Ref. to DS-28, INSPECTION, Hub Unit Bearing.> If the hub bearing is okay, resurface the disc rotor. After resurfacing, check disc rotor thickness as in step 3.

Disc rotor runout limit:

0.075 mm (0.0030 in)

3) Measure disc rotor thickness. If the thickness of disc rotor is below service limit, replace the disc rotor.

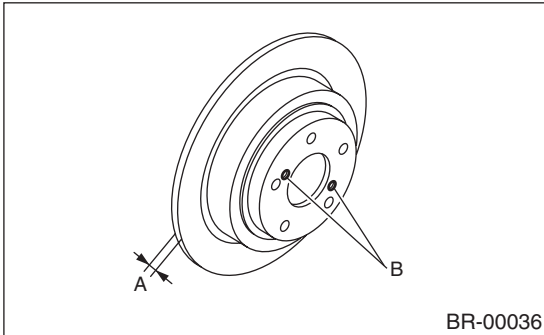

NOTE:
Make sure that micrometer is set 10 mm (0.39 in) inward of rotor outer perimeter.

Disc rotor thickness: A
Standard value
10 mm (0.39 in)
Service limit
8.5 mm (0.335 in)

REAR DISC BRAKE ASSEMBLY

BRAKE

7. Rear Disc Brake Assembly

A: REMOVAL

- 1) Lift-up vehicle and remove wheels.
- 2) Disconnect brake hose from caliper body assembly.

CAUTION:

Do not spill brake fluid on painted surface.
Wash it off immediately.

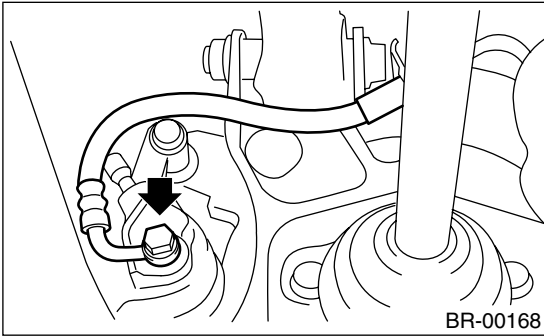

- 3) Remove bolt securing lock pin to caliper body.

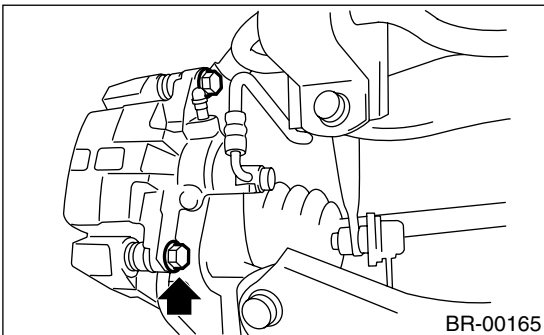

- 4) Raise caliper body and move it toward vehicle center to separate it from support.
- 5) Remove support from back plate.

NOTE:

Remove support only when replacing it or the rotor. It need not be removed when servicing caliper body assembly.

- 6) Clean mud and foreign particles from caliper body assembly and support.

CAUTION:

Be careful not to allow foreign particles to enter inlet (at brake hose connector).

B: INSTALLATION

- 1) Install disc rotor on hub.
- 2) Install support on back plate.

Tightening torque:

78 N·m (8.0 kgf-m, 58 ft-lb)

CAUTION:

- Always replace the pads for both the left and right wheels at the same time. Also replace pad clips if they are twisted or worn.
 - A wear indicator is provided on the inner disc brake pad. If the pad wears down to such an extent that the end of the wear indicator contacts the disc rotor, a squeaking sound is produced as the wheel rotates. If this sound is heard, replace the pad.
 - Replace pads if there is oil or grease on them.
- 3) Apply thin coat of Molykote AS880N (Part No. 26298AC000) to the frictional portion between pad and pad clip.

CAUTION:

Do not allow oil or grease to adhere to the sliding surface of pad and disc rotor.

- 4) Install pads on support.
- 5) Install caliper body on support.

Tightening torque:

39 N·m (4.0 kgf-m, 28.9 ft-lb)

- 6) Connect brake hose.

Tightening torque:

18 N·m (1.8 kgf-m, 13.0 ft-lb)

CAUTION:

- The brake hose must be connected without any twist.
 - Replace brake hose gaskets with new ones.
- 7) Bleed air from brake system.
<Ref. to BR-34, Air Bleeding.>

C: DISASSEMBLY

1) Remove the boot ring.

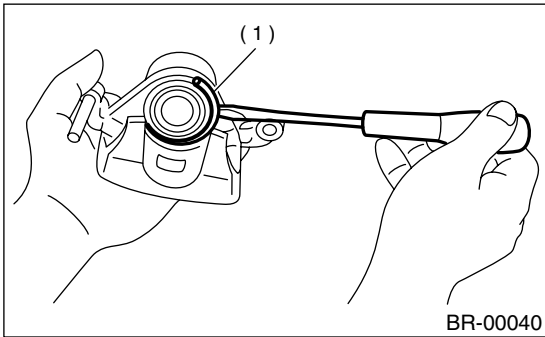

(1) Boot ring

2) Remove the piston boot.

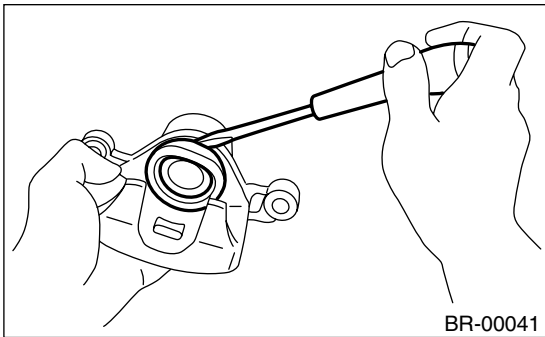

3) Gradually supply compressed air via inlet of caliper body to force piston out.

CAUTION:

- Place a wooden block as shown in Figure to prevent damage to piston.
- Do not apply excessively high-pressure.

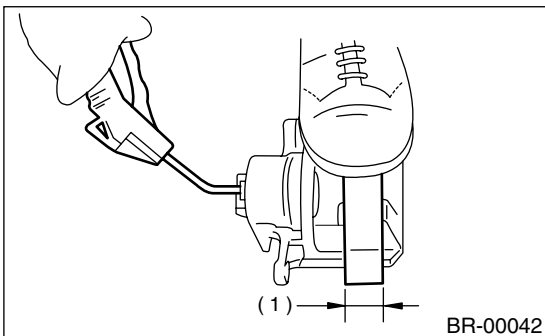

(1) Place a 30 mm (1.18 in) wide wooden block here.

4) Remove piston seal from caliper body cylinder.

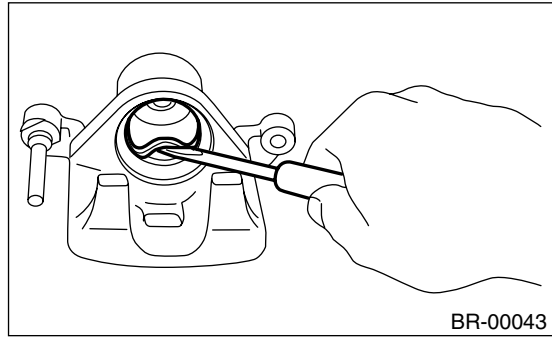

5) Remove lock pin sleeve and boot from caliper body.

6) Remove guide pin boot.

D: ASSEMBLY

1) Clean caliper body interior using brake fluid.

2) Apply a coat of brake fluid to piston seal and fit piston seal in groove on caliper body.

3) Apply a coat of brake fluid to the entire inner surface of cylinder and outer surface of piston.

4) Insert piston into cylinder.

CAUTION:

Do not force piston into cylinder.

5) Apply a coat of specified grease to boot and fit in groove on ends of cylinder and piston.

Grease:

NIGLUBE RX-2 (Part No. 003606000)

6) Install the piston boot to the caliper body, and attach boot ring.

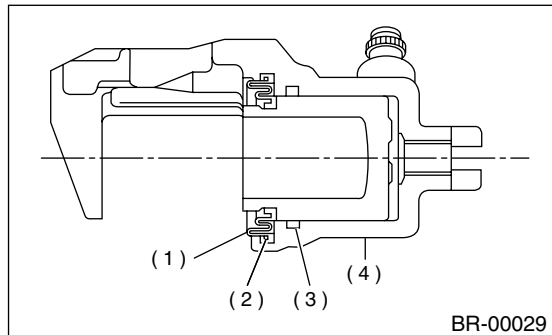

- (1) Piston boot
- (2) Piston
- (3) Piston seal
- (4) Caliper body

REAR DISC BRAKE ASSEMBLY

BRAKE

7) Apply a coat of specified grease to guide pin, outer surface, sleeve outer surface, cylinder inner surface, and boot grooves.

Grease:

NIGLUBE RX-2 (Part No. 003606000)

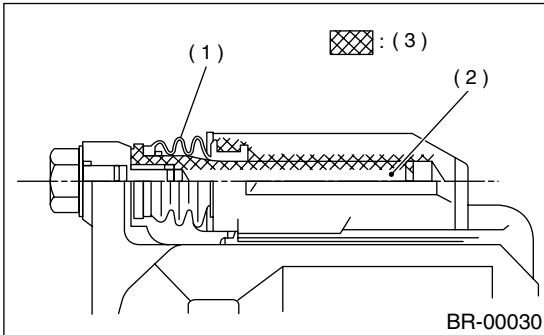

- (1) Pin boot
- (2) Lock pin or guide pin
- (3) Apply grease.

8) Install guide pin boot on caliper body.
9) Install lock pin boot on caliper body and insert lock pin sleeve into place.

E: INSPECTION

- 1) Repair or replace faulty parts.
- 2) Check caliper body and piston for uneven wear, damage or rust.
- 3) Check rubber parts for damage or deterioration.

8. Master Cylinder

A: REMOVAL

- 1) Thoroughly drain brake fluid from reservoir tank.
- 2) Disconnect fluid level indicator harness connector.
- 3) Remove brake pipes from master cylinder.
- 4) Remove master cylinder mounting nuts, and take out master cylinder from brake booster.

CAUTION:

Be extremely careful not to spill brake fluid. Brake fluid spilt on the vehicle body will harm the painted surface; wash it off quickly if spilt.

B: INSTALLATION

To install the master cylinder to the body, reverse the sequence of removal procedure.

Tightening torque:

- Master cylinder mounting nut**
14 N·m (1.4 kgf-m, 10.1 ft-lb)
- Piping flare nut**
15 N·m (1.5 kgf-m, 10.8 ft-lb)

CAUTION:

Be sure to use recommended brake fluid.

C: DISASSEMBLY

1. PRECAUTIONS FOR DISASSEMBLING

- 1) Remove mud and dirt from the surface of brake master cylinder.
- 2) Prepare tools necessary for disassembly operation, and arrange them neatly on work bench.
- 3) Clean work bench.

2. DISASSEMBLING PROCEDURE

- 1) Remove pin with drift pin which secures reserve tank to master cylinder.
- 2) Remove cylinder pin with magnetic pick-up tool while pushing in primary piston.

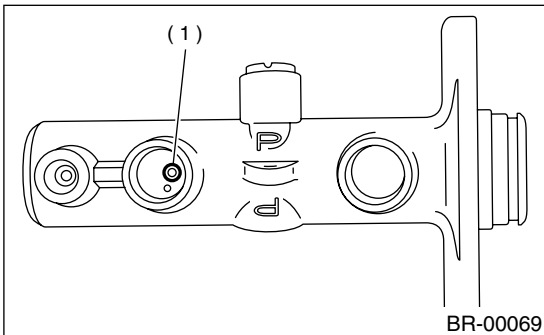

(1) Cylinder pin

- 3) Pry up the pawl and remove the piston retainer. (Without VDC)

NOTE:

Piston may jump out from master cylinder.

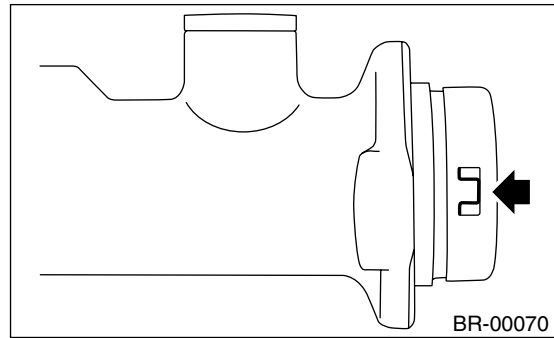

- 4) Using pliers, remove C-ring. (With VDC)

NOTE:

Piston may jump out from master cylinder.

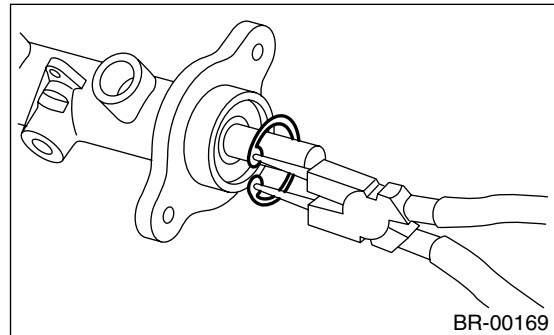

- 5) Extract primary piston assembly and secondary piston assembly.

CAUTION:

- Do not disassemble the piston assembly; otherwise, the spring set value may be changed.
- Use brake fluid or methanol to wash inside wall of cylinder, pistons and piston cups. Be careful not to damage parts when washing. If methanol is used for washing, do not dip rubber parts, such as piston cups, in it for more than 30 seconds; otherwise, they may become swelled.

D: ASSEMBLY

1. PRECAUTIONS FOR ASSEMBLING

- 1) When assembling, be sure to use recommended brake fluid.
- 2) Ensure that the inside wall of cylinder, pistons, and piston cups are free from dirt when assembling.
- 3) Be extremely careful not to damage, scratch, or dent cylinder inside wall, pistons, and piston cups.
- 4) Do not drop parts. Never attempt to use any part that has been dropped accidentally.

MASTER CYLINDER

BRAKE

2. ASSEMBLING PROCEDURE

- 1) Assembling piston assembly:
Apply recommended brake fluid to inside wall of cylinder, and to outer surface of piston assembly, and install piston assemblies carefully into cylinder.
- 2) Assembling cylinder pin:
- 3) Press the pawl and install the piston retainer into the master cylinder. (Without VDC)

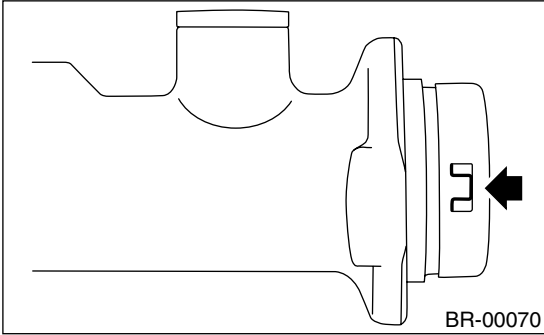

- 4) Using pliers, install C-ring in its groove. (With VDC)

CAUTION:

Make sure to install it firmly to groove.

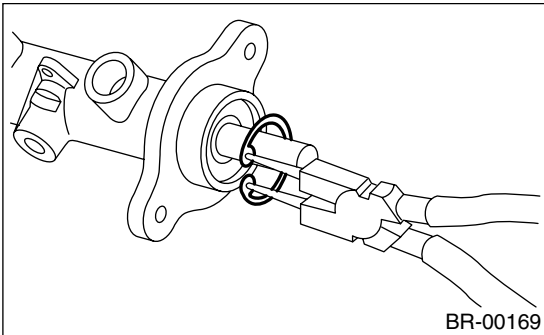

- 5) Install seal to reservoir tank.

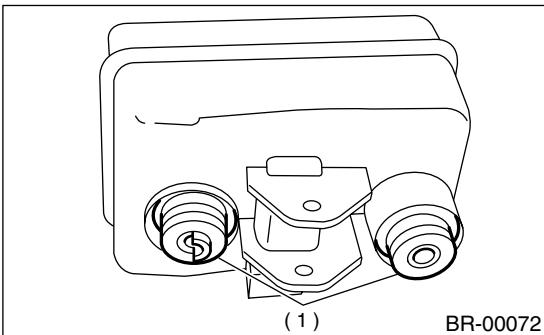

(1) Seal

- 6) Install pin with drift pins which secures reservoir tank to master cylinder.

E: INSPECTION

If any damage, deformation, wear, swelling, rust, and other faults are found on the primary piston assembly, secondary piston assembly, supply valve stopper, or gasket, replace the faulty part.

CAUTION:

- The primary and secondary pistons must be replaced as complete assemblies.
- The service limit of the clearance between each piston and the master cylinder inner dia. is 0.11 mm (0.0043 in).
- When handling parts, be extremely careful not to damage or scratch the parts, or let any foreign matter get on them.

9. Brake Booster

A: REMOVAL

CAUTION:

If external force is applied from above when brake booster is placed in this position, the resin portion as indicated by "P", may be damaged.

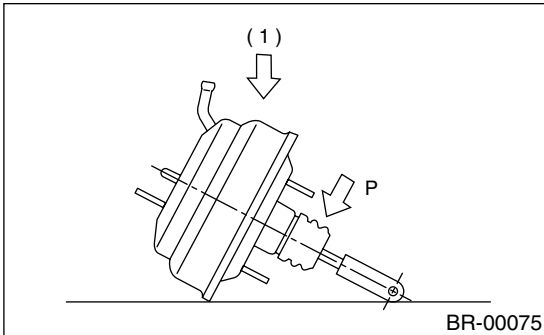

(1) Force

- 1) Pull up parking brake lever, and block tires.
- 2) Disconnect ground cable from battery.
- 3) Remove or disconnect the following parts at engine compartment.
 - (1) Disconnect connector for brake fluid level indicator.
 - (2) Remove brake pipes from master cylinder.
 - (3) Remove master cylinder installing nuts.
 - (4) Disconnect vacuum hose from brake booster.
- 4) Remove the following parts from the pedal bracket.
 - (1) Snap pin and clevis pin
 - (2) Four brake booster installing nuts
- 5) Remove brake booster while shunning brake pipes.

NOTE:

- Be careful not to drop brake booster. Brake booster should be discarded if it has been dropped.
- Use special care when handling operating rod. If excessive force is applied to operating rod, sufficient to cause a change in the angle in excess of $\pm 3^\circ$, it may result in damage to the power piston cylinder.
- Use care when placing brake booster on the floor.
- Do not change the push rod length. If it has been changed, reset the projected length "L" to the standard length.

Standard:

Without VDC

$L = 10 \text{ mm (0.39 in)}$

With VDC

$L = 1.8 \text{ mm (0.071 in)}$

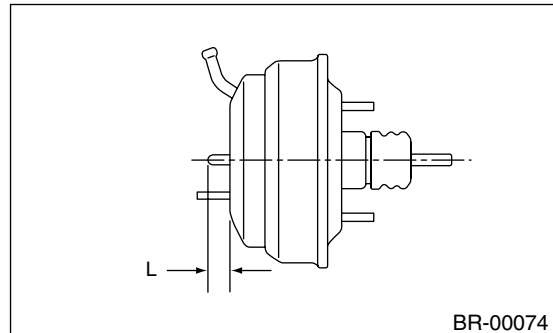

B: INSTALLATION

- 1) Mount brake booster in position.
- 2) Connect operating rod to brake pedal with clevis pin and snap pin.

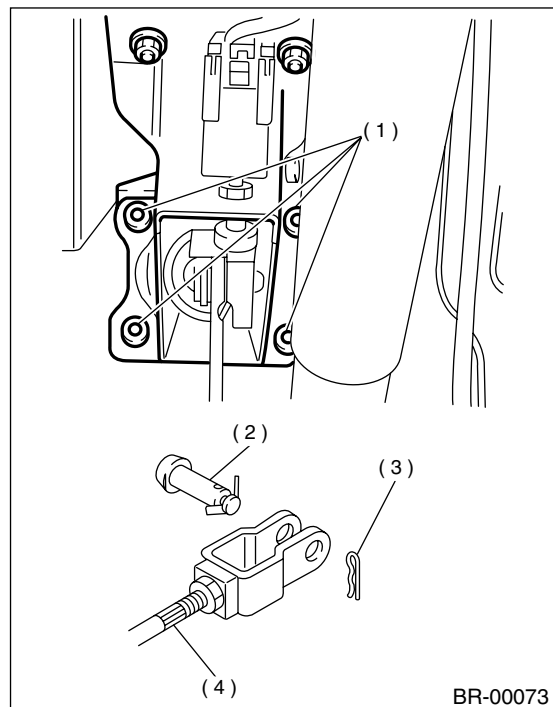

- (1) Nuts
- (2) Clevis pin
- (3) Snap pin
- (4) Operating rod

BRAKE BOOSTER

BRAKE

3) Connect vacuum hose to brake booster.

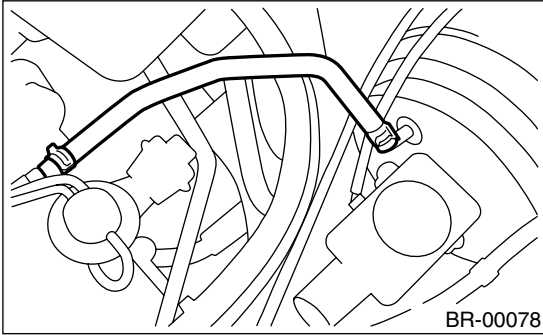

- 4) Mount master cylinder onto brake booster.
- 5) Connect brake pipes to master cylinder.
- 6) Connect electric connector for brake fluid level indicator.
- 7) Adjust operating rod of brake booster.

Standard: L

145.3 mm (5.72 in)

If it is not in specified value, adjust it by adjusting brake booster operating rod.

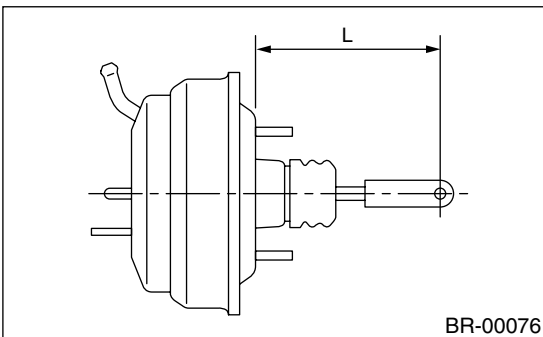

8) Measure the clearance between threaded end of stop light switch and stopper.

If it is not in specified value, adjust it by adjusting position of stop light switch.

CAUTION:

Be careful not to rotate stop light switch.

Stop light switch clearance: A

0.3 mm (0.012 in)

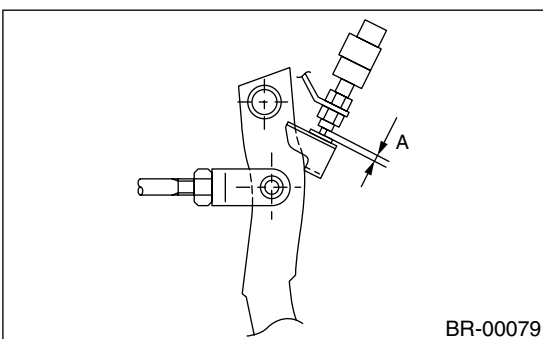

9) Apply grease to operating rod connecting pin to prevent it from wearing.

10) Bleed air from brake system.

Tightening torque (Air bleeder screw):
8 N·m (0.8 kgf-m, 5.8 ft-lb)

11) Conduct road tests to ensure brakes do not drag.

C: INSPECTION

1. OPERATION CHECK (WITHOUT GAUGES)

CAUTION:

When checking operation, be sure to securely apply the hand brake.

• **Checking without gauges**

This method cannot determine the exact portion which has failed, but it can provide a rough understanding of the nature of the failure if checking is conducted in accordance with the following procedures.

• **Air tightness check**

Start engine, and run it for 1 to 2 minutes, then turn it off. Depress brake pedal several times applying the same pedal force as that used in ordinary braking operations. The pedal stroke should be greatest on the 1st depression, and it should become smaller with each successive depression. If no change occurs in the pedal height while in a depressed state, brake booster is faulty.

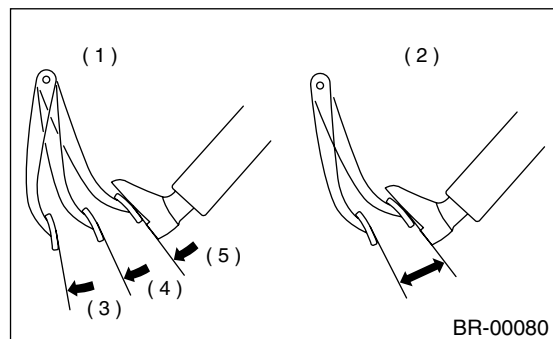

- (1) OK
- (2) NOT OK
- (3) 1st
- (4) 2nd
- (5) 3rd

NOTE:

- In the event of defective operation, inspect the condition of the check valve and vacuum hose.
- Replace them if faulty and conduct the test again.
- If no improvement is observed, check precisely with gauges.

• Operation check

1) With engine off, depress brake pedal several times applying the same pedal force and make sure that the pedal height does not vary with each depression of the pedal.

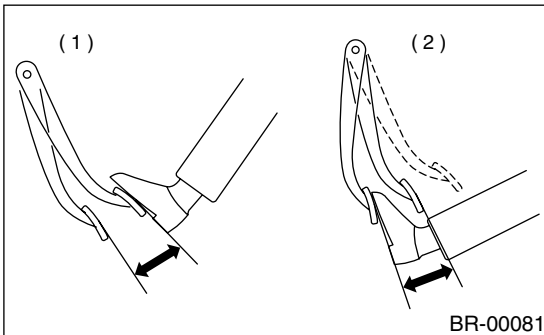

- (1) When engine is stopped
- (2) When engine is started

2) With brake pedal depressed, start engine.
 3) As engine starts, brake pedal should move slightly toward the floor. If no change occurs in the pedal height, brake booster is faulty.

NOTE:

If faulty, check precisely with gauges.

• Loaded air tightness check

Depress brake pedal while engine is running, and turn off engine while the pedal is still depressed. Keep the pedal depressed for 30 seconds; if no change occurs in the pedal height, brake booster is functioning normally; if the pedal height increases, it is faulty.

NOTE:

If faulty, check precisely with gauges.

2. OPERATION CHECK (WITH GAUGES)

CAUTION:

When checking operation, be sure to securely apply the hand brake.

• Checking with gauges

Connect gauges as shown in Figure. After bleeding air from pressure gauges, proceed to each check.

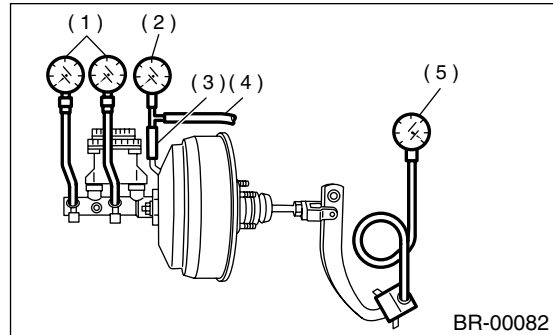

- (1) Pressure gauge
- (2) Vacuum gauge
- (3) Adapter hose
- (4) Vacuum hose
- (5) Pedal force gauge

• Air tightness check

1) Start engine and keep it running until a vacuum of 66.7 kPa (500 mmHg, 19.69 inHg) = point A is indicated on vacuum gauge. Do not depress brake pedal.

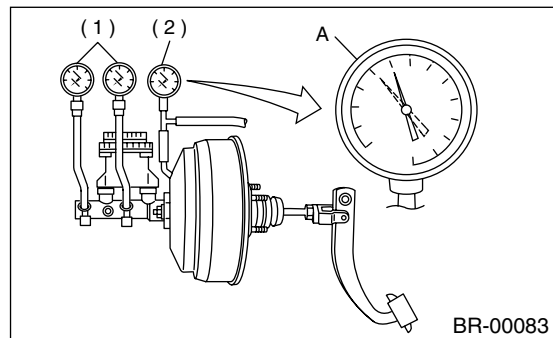

- (1) Pressure gauge
- (2) Vacuum gauge

2) Stop engine and watch the gauge. If the vacuum drop range is less than 3.3 kPa (25 mmHg, 0.98 in-Hg) within 15 seconds after stopping engine, brake booster is functioning properly.

If defective, the cause may be one of those listed below.

- Check valve malfunction
- Leak from vacuum hose
- Leak from the shell jointed portion or stud bolt welded portion

BRAKE BOOSTER

BRAKE

- Damaged diaphragm
- Leak from valve body seal and bearing portion
- Leak from plate and seal assembly portion
- Leak from poppet valve assembly portion
- **Loaded air tightness check**

1) Start engine and depress brake pedal with pedal force of 196 N (20 kgf, 44 lb). Keep engine running until a vacuum of 66.7 kPa (500 mmHg, 19.69 inHg) = point B is indicated on vacuum gauge while the pedal is still depressed.

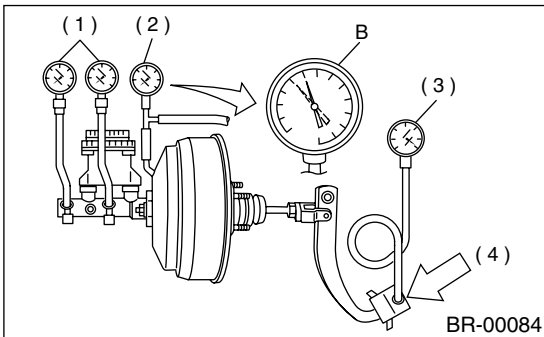

- (1) Pressure gauge
- (2) Vacuum gauge
- (3) Pedal force gauge
- (4) Depress

2) Stop engine and watch vacuum gauge.

If the vacuum drop range is less than 3.3 kPa (25 mmHg, 0.98 inHg) within 15 seconds after stopping engine, brake booster is functioning properly.

If defective, refer to "AIR TIGHTNESS CHECK".

<Ref. to BR-28, INSPECTION, Brake Booster.>

- **Lack of boosting action check**

Turn off engine, and set the vacuum gauge reading at "0". Then, check the fluid pressure when brake pedal is depressed. The pressure must be greater than the standard value listed.

| | | |
|-------------------|--|--|
| Brake pedal force | 147 N (15 kgf, 33 lb) | 294 N (30 kgf, 66 lb) |
| Fluid pressure | 588 kPa (6 kg/cm ² , 85 psi) | 1,569 kPa (16 kg/cm ² , 228 psi) |

- **Boosting action check**

Set the vacuum gauge reading at 66.7 kPa (500 mmHg, 19.69 inHg) by running engine. Then, check the fluid pressure when brake pedal is depressed. The pressure must be greater than the standard value listed.

| | | |
|-------------------|--|--|
| Brake pedal force | 147 N (15 kgf, 33 lb) | 294 N (30 kgf, 66 lb) |
| Fluid pressure | 6,178 kPa (63 kg/cm ² , 896 psi) | 9,709 kPa (99 /cm ² , 1,408 psi) |

10. Proportioning Valve

A: REMOVAL

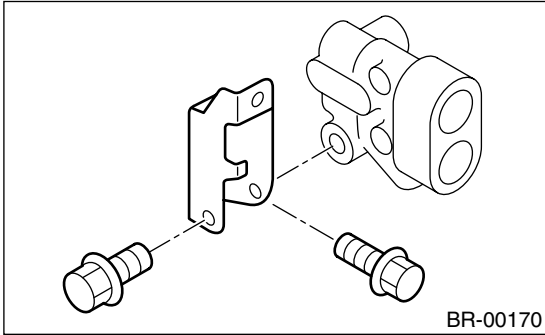

- 1) Pull up parking brake lever, and block the tires.
- 2) Remove brake pipe from proportioning valve at four places.
- 3) Remove proportioning valve from its bracket.

CAUTION:

Do not disassemble or adjust the proportioning valve. (The proportioning valve must be replaced as an assembly.)

B: INSTALLATION

- 1) Install proportioning valve to bracket.
- 2) Connect brake pipes correctly to proportioning valve.
- 3) Bleed air, then check each joint of brake pipe for oil leaks.

Tightening torque:

Proportioning valve to brake pipe flare nut:

15 N·m (1.5 kgf-m, 10.8 ft-lb)

Proportioning valve to bracket:

18 N·m (1.8 kgf-m, 13.0 ft-lb)

C: INSPECTION

- 1) Install oil pressure gauges to measure the master cylinder fluid pressure (front wheel brake fluid pressure) and rear wheel cylinder fluid pressure.
- 2) Bleed air from oil pressure gauges.
- 3) Check the master cylinder fluid pressure and rear wheel cylinder fluid pressure.

The standard values are shown in Figure.

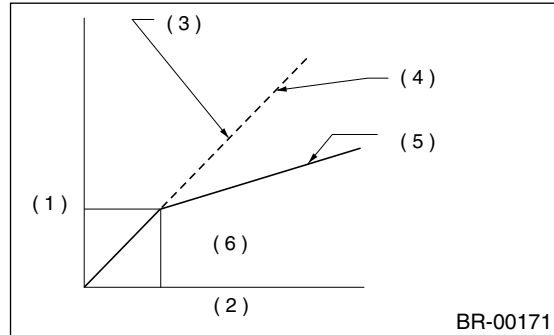

- (1) Rear wheel cylinder fluid pressure: P3
- (2) Master cylinder fluid pressure: P2
- (3) In case of failure in one circuit
- (4) Without ABS model
- (5) With ABS model
- (6) When both circuits are normal

- 4) For the oil pressure in case of split point, refer to "SPECIFICATIONS".

<Ref. to BR-2, SPECIFICATIONS, General Description.>

11. Brake Fluid

A: INSPECTION

1) Check that brake fluid level remains between "MIN" and "MAX". If out of the specified range, refill or drain fluid. If fluid level becomes close to "MIN", refill fluid.

2) Check fluid for discoloration. If fluid color has excessively changed, drain the fluid and refill with new fluid.

B: REPLACEMENT

CAUTION:

- Be extremely careful not to spill brake fluid. Brake fluid spilt on the vehicle body will harm the painted surface; wash it off quickly if spilt.
- To always maintain the brake fluid characteristics, replace the brake fluid according to maintenance schedule or earlier than that when used in severe condition.
- The FMVSS No. 116, fresh DOT3 or 4 brake fluid must be used.
- Cover bleeder with waste cloth, when loosening it, to prevent brake fluid from being splashed over surrounding parts.
- Avoid mixing different brands of brake fluid to prevent degrading the quality of the fluid.
- Be careful not to allow dirt or dust to get into the reservoir tank.

NOTE:

- During bleeding operation, keep the brake reservoir tank filled with brake fluid to eliminate entry of air.
 - Brake pedal operation must be very slow.
 - For convenience and safety, two people should do the work.
 - The amount of brake fluid required is approximately 500 mℓ (16.9 US fl oz, 17.6 Imp fl oz) for total brake system.
- 1) Either jack-up vehicle and place a safety stand under it, or lift up vehicle.
 - 2) Remove both front and rear wheels.
 - 3) Draw out the brake fluid from master cylinder with syringe.
 - 4) Refill reservoir tank with recommended brake fluid.

Recommended brake fluid:

FMVSS No. 116, fresh DOT3 or 4 brake fluid

- 5) Install one end of a vinyl tube onto the air bleeder and insert the other end into a container to collect the brake fluid.

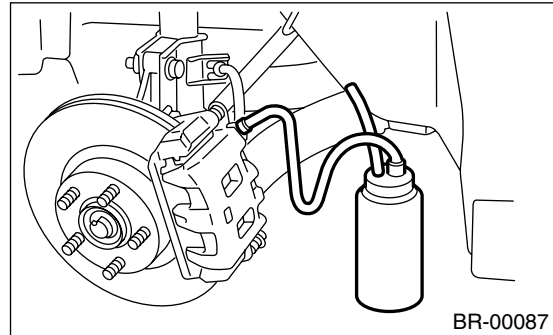

CAUTION:

Brake fluid replacement sequence; (A) Front right → (B) Rear left → (C) Front left → (D) Rear right

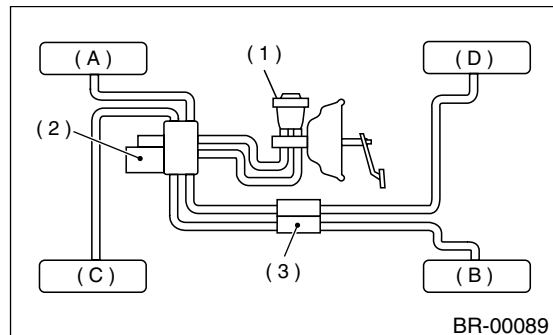

- (1) Master cylinder
- (2) Hydraulic unit
- (3) Proportioning valve

- 6) Instruct your co-worker to depress the brake pedal slowly two or three times and then hold it depressed.
- 7) Loosen bleeder screw approximately 1/4 turn until a small amount of brake fluid drains into container, and then quickly tighten screw.
- 8) Repeat steps 6) and 7) above until there are no air bubbles in drained brake fluid and new fluid flows through vinyl tube.

NOTE:

Add brake fluid as necessary while performing the air bleed operation, in order to prevent the tank from running short of brake fluid.

- 9) After completing the bleeding operation, hold brake pedal depressed and tighten screw and install bleeder cap.

Tightening torque (Bleeder screw):

8 N·m (0.8 kgf-m, 5.8 ft-lb)

- 10) Bleed air from each wheel cylinder using the same procedures as described in steps 6) through 7) above.

11) Depress brake pedal with a force of approximately 294 N (30 kgf, 66 lb) and hold it there for approximately 20 seconds. At this time check pedal to see if it shows any unusual movement.

Visually inspect bleeder screws and brake pipe joints to make sure that there is no fluid leakage.

12) Install wheels, and drive vehicle for a short distance between 2 to 3 km (1 to 2 miles) to make sure that brakes are operating properly.

12. Air Bleeding

A: PROCEDURE

CAUTION:

- The FMVSS No. 116, fresh DOT3 or 4 brake fluid must be used.
- Cover bleeder with waste cloth when loosening it to prevent brake fluid from being splashed over surrounding parts.
- Avoid mixing different brands of brake fluid to prevent degrading the quality of the fluid.
- Be careful not to allow dirt or dust to get into the reservoir tank.
- Be extremely careful not to spill brake fluid. Brake fluid spilt on the vehicle body will harm the painted surface; wash it off quickly if spilt.

NOTE:

- Start with the brakes (wheels) connected to the secondary chamber of the master cylinder.
- The time interval between two brake pedal operations (from the time when the pedal is released to the time when it is depressed another time) should be approximately 3 seconds.
- The air bleeder on each brake should be released for 1 to 2 seconds.

1. MASTER CYLINDER

NOTE:

- If master cylinder is disassembled or reservoir tank is empty, bleed master cylinder.
 - During bleeding operation, keep the brake reservoir tank filled with brake fluid to eliminate entry of air.
 - Brake pedal operation must be very slow.
 - For convenience and safety, two people should do the work.
- 1) Loosen wheel nuts, jack-up vehicle, support it with safety stands, and remove wheel.
 - 2) Disconnect brake line at primary and secondary sides.
 - 3) Put plastic bag cover on the master cylinder.
 - 4) Carefully depress and hold brake pedal.

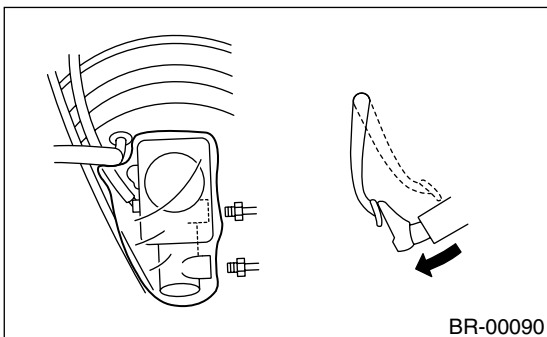

- 5) Close outlet plug with your finger, and release brake pedal.

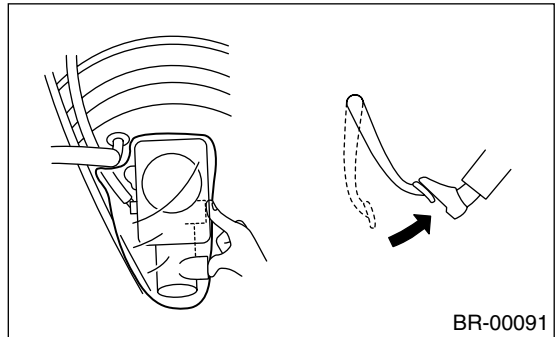

- 6) Repeat above steps 4) and 5) until master cylinder is completely bled.
- 7) Install brake pipes to master cylinder.

Tightening torque:

8 N·m (0.8 kgf-m, 5.8 ft-lb)

- 8) Cleanly wash away brake fluid spilt on master cylinder etc.
- 9) Bleed air from brake system. <Ref. to BR-34, BRAKE LINE, PROCEDURE, Air Bleeding.>

2. BRAKE LINE

NOTE:

- During bleeding operation, keep the brake reservoir tank filled with brake fluid to eliminate entry of air.
 - Brake pedal operation must be very slow.
 - For convenience and safety, two people should do the work.
- 1) Make sure that there is no leak from joints and connections of the brake system.
 - 2) Fit one end of vinyl tube into the air bleeder and put the other end into a brake fluid container.

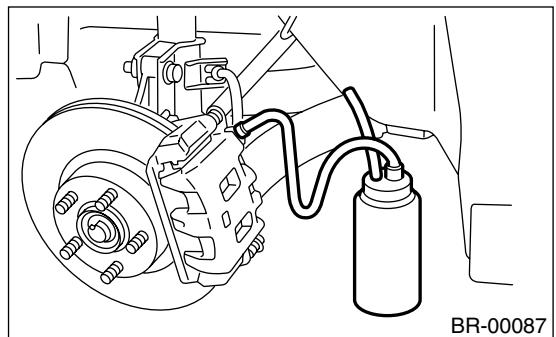

CAUTION:

Brake fluid replacement sequence; (A) Front right → (B) Rear left → (C) Front left → (D) Rear right

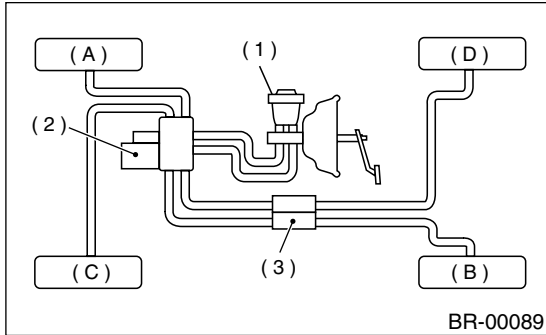

- (1) Master cylinder
- (2) Hydraulic unit
- (3) Proportioning valve

3) Slowly depress the brake pedal and keep it depressed. Then, open the air bleeder to discharge air together with the fluid.

Release air bleeder for 1 to 2 seconds.

Next, with the bleeder closed, slowly release the brake pedal.

Repeat these steps until there are no more air bubbles in the vinyl tube.

Allow 3 to 4 seconds between two brake pedal operations.

CAUTION:

Cover bleeder with waste cloth, when loosening it, to prevent brake fluid from being splashed over surrounding parts.

NOTE:

Brake pedal operating must be very slow.

4) Tighten air bleeder securely when no air bubbles are visible.

Air bleeder tightening torque:

8 N·m (0.8 kgf-m, 5.8 ft-lb)

5) Perform these steps for the brakes connecting to the secondary chamber of master cylinder, first, and then for the ones connecting to primary chamber. With all procedures completed, fully depress the brake pedal and keep it in that position for approximately 20 seconds to make sure that there is no leak evident in the entire system.

6) Check the pedal stroke.

While the engine is idling, depress the brake pedal with a 490 N (50 kgf, 110 lb) load and measure the distance between the brake pedal and steering wheel. With the brake pedal released, measure the distance between the pedal and steering wheel again. The difference between the two measurements must be more than specified.

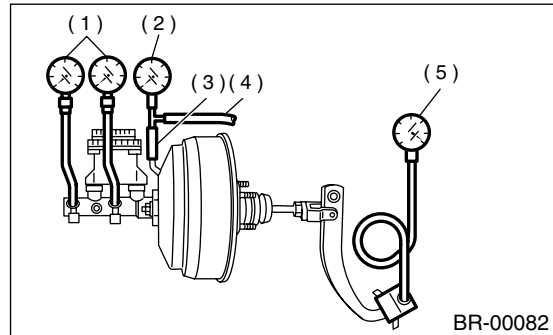

- (1) Pressure gauge
- (2) Vacuum gauge
- (3) Adapter hose
- (4) Vacuum hose
- (5) Pedal force gauge

Specified pedal stroke:

95 mm (3.74 in)

When depressing brake pedal with a 490 N (50 kgf, 110 lb) load.

7) If the distance is more than specifications, there is a possibility that air is in the brake line. Bleed brake line until pedal stroke meets the specification.

8) Operate hydraulic control unit in the sequence control mode.

With ABS: <Ref. to ABS-9, ABS Sequence Control.>

With VDC: <Ref. to VDC-19, VDC Sequence Control.>

9) Recheck the brake stroke.

10) If the distance is more than specifications, there is a possibility air is in the inside of the hydraulic unit. Repeat above steps 2) to 9) above until pedal stroke meets the specification.

11) Add brake fluid to the required level (MAX. level) of reservoir tank.

12) As a final step, test run the vehicle at low speed and apply brakes relatively hard 2 to 3 times to ensure that brakes provide normal braking action on all four wheels without dragging and uneven braking.

13. Brake Hose

A: REMOVAL

1. FRONT BRAKE HOSE

1) Separate brake pipe from brake hose.

NOTE:

Always use flare nut wrench and be careful not to deform flare nut.

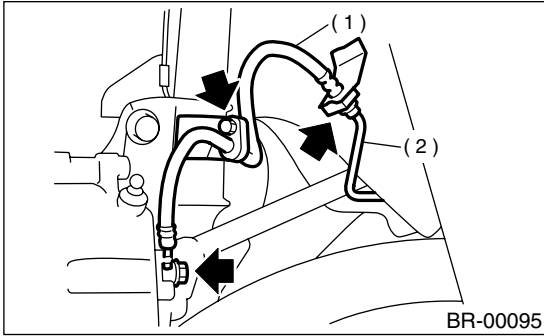

- (1) Brake hose
- (2) Brake pipe

- 2) Pull out clamp to remove brake hose.
- 3) Remove bolt at strut and union bolt.

2. REAR BRAKE HOSE

1) Separate brake pipe from brake hose.

NOTE:

Always use flare nut wrench and be careful not to deform flare nut.

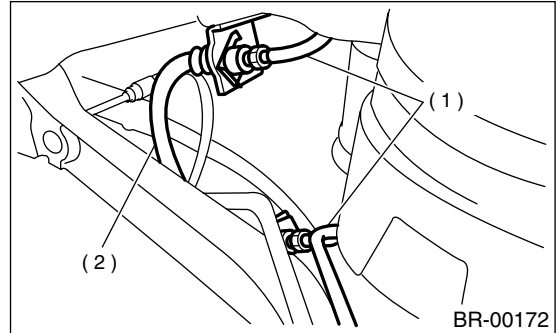

- (1) Brake pipe
- (2) Brake hose



- (1) Brake pipe

- 2) Pull out clamp to remove brake hose.

B: INSTALLATION

1. FRONT BRAKE HOSE

- 1) Route end of brake hose (on caliper side) through hole in brake hose bracket at strut location.
- 2) Tighten end of brake hose at caliper using a union bolt.

Tightening torque (Union bolt):
18 N·m (1.8 kgf-m, 13.0 ft-lb)

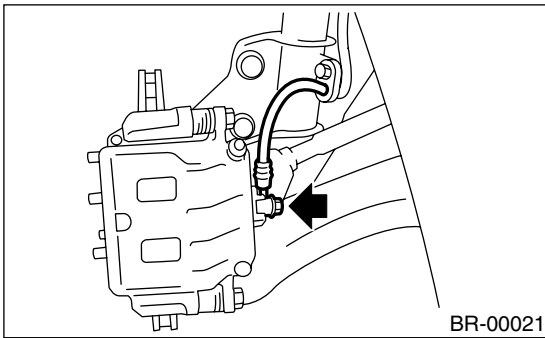

- 3) Secure middle fitting of brake hose to bracket at strut location using a clamp.
- 4) Position disc in straight-forward direction and route brake hose through hole in bracket on wheel apron side.

CAUTION:

Be sure brake hose is not twisted.

- 5) Temporarily tighten flare nut to connect brake pipe and hose.
- 6) Fix brake hose with clamp at wheel apron bracket.
- 7) While holding hexagonal part of brake hose fitting with a wrench, tighten flare nut to the specified torque.

Tightening torque (Brake pipe flare nut):
15 N·m (1.5 kgf-m, 10.8 ft-lb)

- 8) Bleed air from the brake system.

2. REAR BRAKE HOSE

- 1) Pass brake hose through the hole of bracket, and lightly tighten flare nut to connect brake pipe.
- 2) Insert clamp upward to fix brake hose.
- 3) While holding hexagonal part of brake hose fitting with a wrench, tighten flare nut to the specified torque.

Tightening torque (Brake pipe flare nut):
15 N·m (1.5 kgf-m, 10.8 ft-lb)

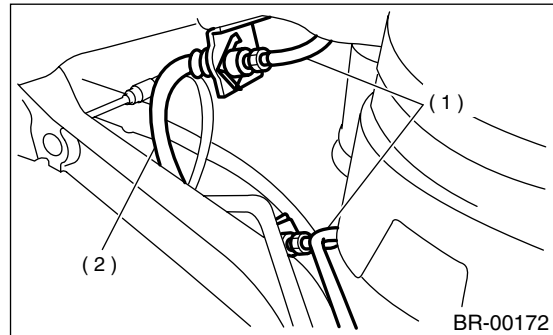

- (1) Brake pipe
- (2) Brake hose

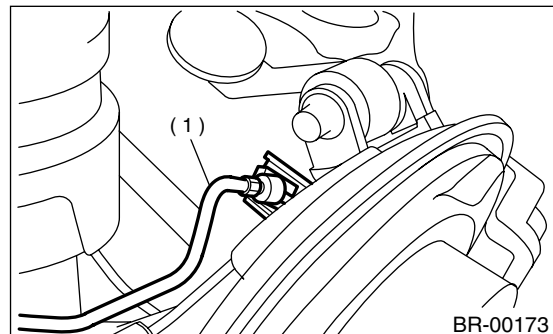

- (1) Brake pipe

- 4) Bleed air from the brake system.

C: INSPECTION

Ensure there are no cracks, breakage, or damage on hoses. Check joints for fluid leakage. If any cracks, breakage, damage or leakage is found, repair or replace hose.

14.Brake Pipe

A: REMOVAL

NOTE:

Airbag system wiring harness is routed near the center brake pipe.

CAUTION:

- All airbag system wiring harness and connectors are colored yellow. Do not use electrical test equipment on these circuits.
- Be careful not to damage airbag system wiring harness when servicing the center brake pipe.
- When removing the brake pipe, make sure that it is not bent.

B: INSTALLATION

NOTE:

Airbag system wiring harness is routed near the center brake pipe.

CAUTION:

- All airbag system wiring harness and connectors are colored yellow. Do not use electrical test equipment on these circuits.
- Be careful not to damage airbag system wiring harness when servicing the center brake pipe.
- When installing the brake pipe, make sure that it is not bent.
- After installing the brake pipe and hose, bleed the air.
- After installing the brake hose, make sure that it does not touch the tire or suspension assembly, etc.

Brake pipe tightening torque:

15 N·m (1.5 kgf-m, 10.8 ft-lb)

C: INSPECTION

Ensure there are no cracks, breakage, or damage on pipes. Check joints for fluid leakage. If any cracks, breakage, damage or leakage is found, repair or replace pipe.

NOTE:

Use a mirror when inspecting low-visible part or back side.

15.Brake Pedal

A: REMOVAL

1. MT MODEL

- 1) Pull up parking brake lever and block tires.
- 2) Disconnect ground cable from battery.
- 3) Remove steering column.
<Ref. to PS-21, REMOVAL, Tilt Steering Column.>
- 4) Disconnect connectors from stop light and clutch switches.
- 5) Remove snap pins which secure lever to push rod and operating rod.
- 6) Remove clevis pins which secure lever to push rod and operating rod.

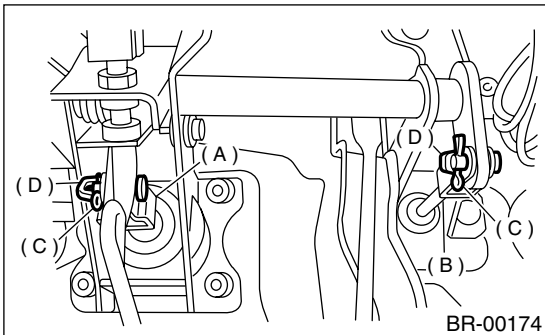

- (A) Operating rod
(B) Push rod
(C) Snap pin
(D) Clevis pin

- 7) Remove nut which secures clutch master cylinder.

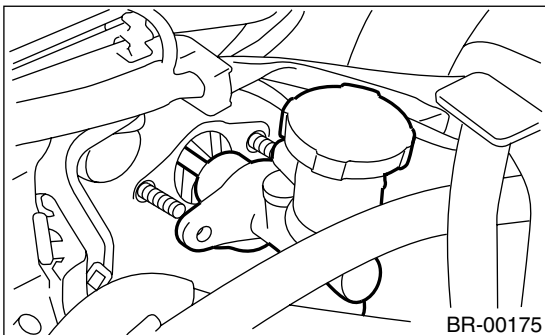

- 8) Remove bolts and nuts which secure brake and clutch pedals, and remove pedal assembly.

2. AT MODEL

- 1) Pull up parking brake lever.
- 2) Disconnect ground cable from battery.
- 3) Remove instrument panel lower cover from instrument panel.
- 4) Remove clevis pin which secures brake pedal to brake booster operating rod. Also disconnect stop light switch connector.

- 5) Remove AT unit from brake panel (2 nuts).
- 6) Remove two bolts and four nuts which secure brake pedal to pedal.

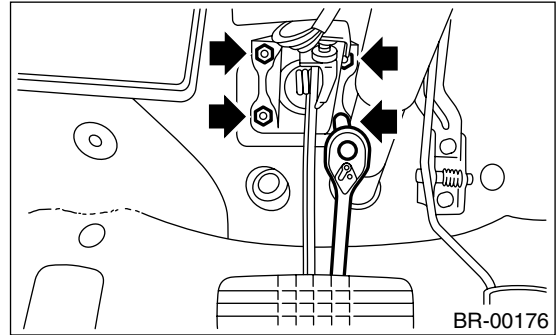

B: INSTALLATION

- 1) Install in the reverse order of removal.

CAUTION:

- If cable clamp is damaged, replace it with a new one.
- Never fail to cover outer cable end with boot.
- Be careful not to kink accelerator cable.
- Always use new clevis pins.

- 2) Adjustment of clutch pedal <Ref. to BR-40, ASSEMBLY, Brake Pedal.>
- 3) Inspect after pedal installation <Ref. to BR-41, INSPECTION, Brake Pedal.>

C: DISASSEMBLY

1. MT MODEL

- 1) Remove the brake switch.
<Ref. to BR-42, REMOVAL, Stop Light Switch.>
- 2) Remove the clutch pedal.
<Ref. to CL-28, DISASSEMBLY, Clutch Pedal.>
- 3) Remove the clutch master cylinder bracket.

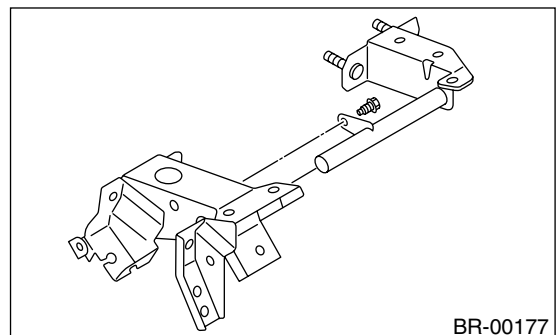

BRAKE PEDAL

BRAKE

4) Remove bushing, spring and stopper.

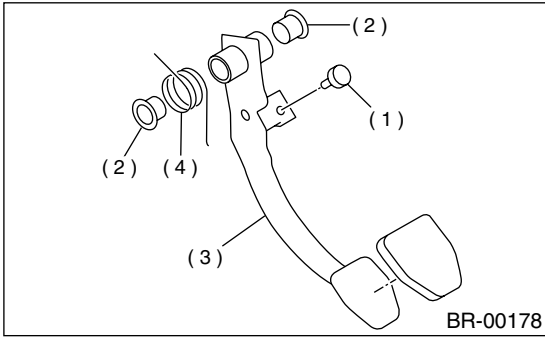

- (1) Stopper
- (2) Bushing
- (3) Brake pedal
- (4) Brake pedal spring

5) Remove the brake pedal pad.

2. AT MODEL

- 1) Remove the brake switch.
- 2) Unbolt, and then remove the brake pedal.

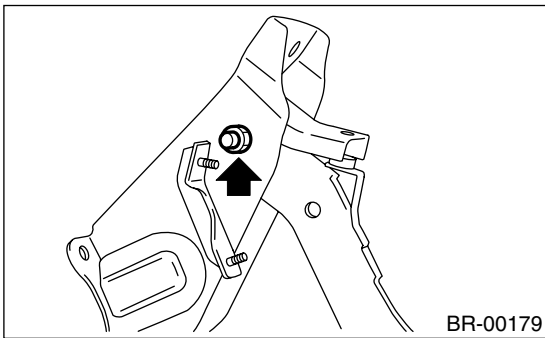

3) Remove bushing, spacer and spring.

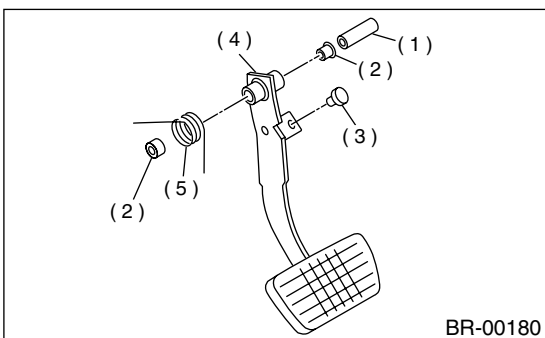

- (1) Spacer
- (2) Bushing
- (3) Stopper
- (4) Brake pedal
- (5) Brake pedal spring

4) Remove the brake pedal pad.

D: ASSEMBLY

- 1) Attach stop light switch, etc. to pedal bracket temporarily.
- 2) Clean inside of bores of clutch pedal and brake pedal, apply grease, and set bushings into bores.
- 3) Align bores of pedal bracket, clutch pedal and brake pedal, attach brake pedal return spring and clutch pedal effort reducing spring (vehicle with hill holder), and then install pedal bolt.

NOTE:

Clean up inside of bushings and apply grease before installing spacer.

Tightening torque:

T: 29 N·m (3.0 kgf-m, 21.7 ft-lb)

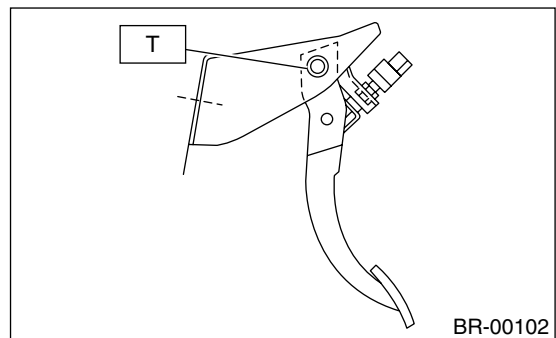

4) Set brake pedal position by adjusting position of stop light switch.

Pedal position: L

126.4 mm (4.98 in)

Tightening torque:

T: 8 N·m (0.8 kgf-m, 5.8 ft-lb)

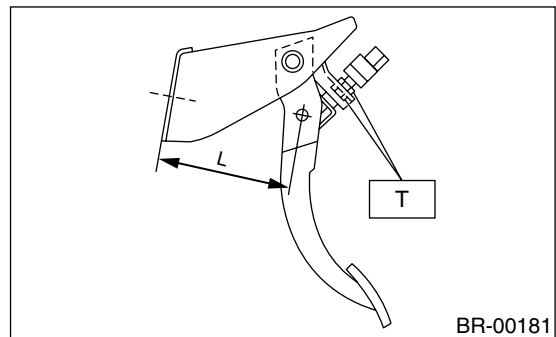

E: INSPECTION

1) Move brake and clutch pedal pads in the lateral direction with a force of approximately 10 N (1 kgf, 2 lb) to ensure pedal deflection is in specified range.

CAUTION:

If excessive deflection is noted, replace bushings with new ones.

Deflection of brake and clutch pedal:

Service limit

5.0 mm (0.197 in) or less

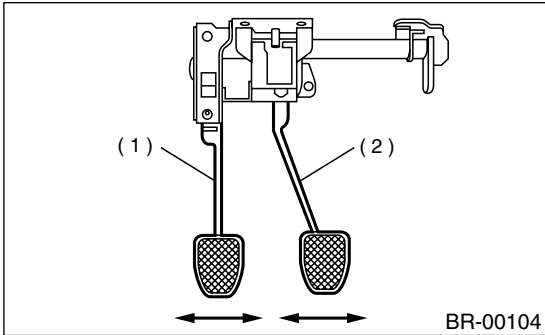

- (1) Clutch pedal
- (2) Brake pedal

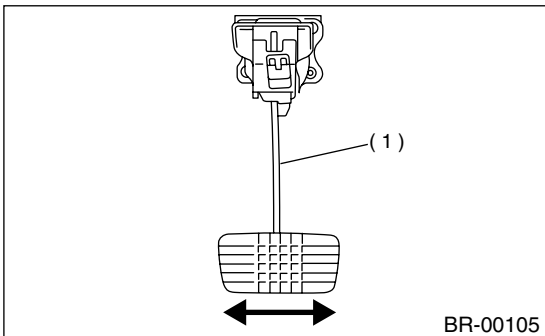

- (1) Brake pedal

2) Check position of pedal pad.

Pedal height: L

AT: 158 mm (6.22 in)

MT: 153 mm (6.02 in)

Brake pedal free play: A

1 — 3 mm (0.04 — 0.12 in) [Depress brake pedal pad with a force of less than 10 N (1 kgf, 2 lb).]

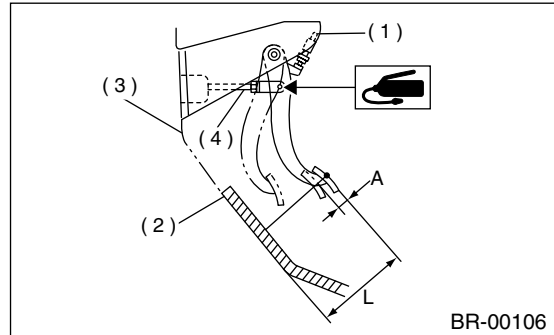

- (1) Stop light switch
- (2) Mat
- (3) Toe board
- (4) Brake booster operating rod

3) If it is not in specified value, adjust it by adjusting brake booster operating rod length.

STOP LIGHT SWITCH

BRAKE

16. Stop Light Switch

A: REMOVAL

- 1) Disconnect ground cable from battery.
- 2) Disconnect stop light switch connector.
- 3) Loosen nuts, and unscrew stop light switch to remove.

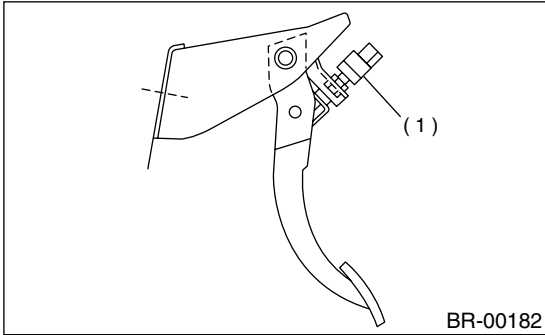

(1) Stop light switch

B: INSTALLATION

- 1) Screw the stop light switch onto a bracket and secure it temporarily with a nut.
 - 2) Adjust stop light switch position, and then tighten the nut.
- <Ref. to BR-43, ADJUSTMENT, Stop Light Switch.>

Tightening torque:

8 N·m (0.8 kgf-m, 5.8 ft-lb)

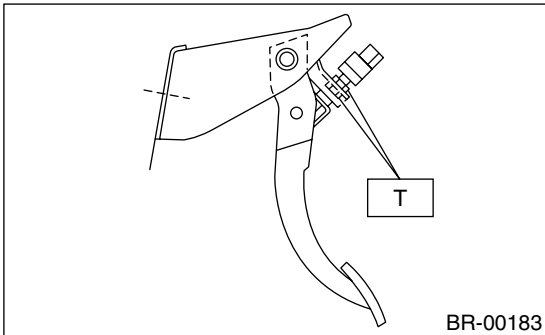

C: INSPECTION

- 1) If stop light switch does not operate properly (or if it does not stop at the specified position), replace with a new one.

Specified position: L

$2^{+1.5}/_0$ mm ($0.079^{+0.059}/_0$ in)

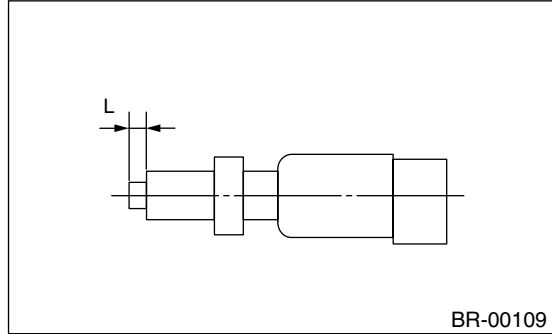

- 2) Measure the clearance between threaded end of stop light switch and stopper.

CAUTION:

Be careful not to rotate stop light switch.

Stop light switch clearance: A

0.3 mm (0.012 in)

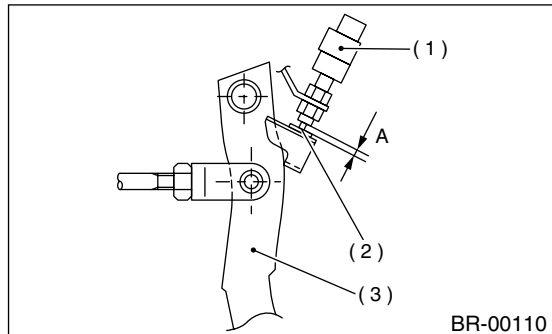

- (1) Stop light switch
- (2) Stopper
- (3) Brake pedal

- 3) If it is not in specified value, adjust it by adjusting position of stop light switch.

CAUTION:

Be careful not to rotate stop light switch.

D: ADJUSTMENT

Loosen the lock nut, and adjust stop light switch position until the clearance (A) between threaded end of the stop light switch and the stopper becomes 0.3 mm (0.012 in). Then, tighten the lock nut.

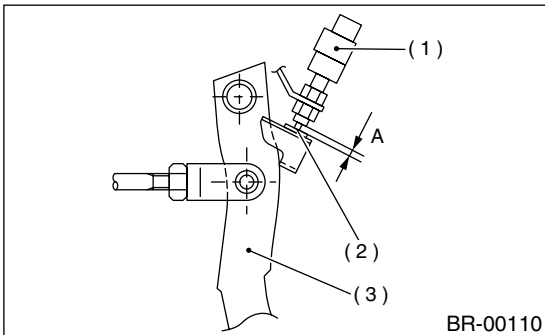

- (1) Stop light switch
- (2) Stopper
- (3) Brake pedal

GENERAL DIAGNOSTICS

BRAKE

17. General Diagnostics

A: INSPECTION

| | Trouble and possible cause | Corrective action |
|---|---|--|
| 1. Insufficient braking | (1) Fluid leakage from the hydraulic mechanism | Repair or replace (cup, piston seal, piston boot, master cylinder piston kit, pipe or hose). |
| | (2) Entry of air into the hydraulic mechanism | Bleed the air. |
| | (3) Excessively wide shoe clearance | Adjust the clearance. |
| | (4) Wear, deteriorated surface material, adhering water or fluid on the lining | Replace, grind or clean. |
| | (5) Improper operation of master cylinder, disc caliper, brake booster or check valve | Correct or replace. |
| 2. Unstable or uneven braking | (1) Fluid on the lining or rotor | Eliminate cause of fluid leakage, clean, or replace. |
| | (2) Rotor eccentricity | Correct or replace the rotor. |
| | (3) Improper lining contact, deteriorated surface material, improper inferior material, or wear | Correct by grinding, or replace. |
| | (4) Deformed back plate | Correct or replace. |
| | (5) Improper tire inflation | Inflate to correct pressure. |
| | (6) Disordered wheel alignment | Adjust alignment. |
| | (7) Loosened back plate or the support installing bolts | Retighten. |
| | (8) Loosened wheel bearing | Retighten to normal tightening torque or replace. |
| | (9) Trouble in the hydraulic system | Replace the cylinder, brake pipe or hose. |
| | (10) Uneven effect of the parking brake | Check, adjust, or replace the rear brake and cable system. |
| 3. Excessive pedal stroke | (1) Entry of air into the hydraulic mechanism | Bleed the air. |
| | (2) Excessive play in the master cylinder push rod | Adjust. |
| | (3) Fluid leakage from the hydraulic mechanism | Repair or replace (cup, piston seal, piston boot, master cylinder piston kit, pipe or hose). |
| | (4) Improperly adjusted shoe clearance | Adjust. |
| | (5) Improper lining contact or worn lining | Correct or replace. |
| 4. Brake dragging or improper brake return | (1) Insufficient pedal play | Adjust play. |
| | (2) Improper master cylinder return | Clean or replace the cylinder. |
| | (3) Clogged hydraulic system | Replace. |
| | (4) Improper return or adjustment of parking brake | Correct or adjust. |
| | (5) Weakened spring tension or breakage of shoe return spring | Replace the spring. |
| | (6) Excessively narrow shoe clearance | Adjust the clearance. |
| | (7) Improper disc caliper operation | Correct or replace. |
| | (8) Improper adjusted wheel bearing | Adjust or replace. |
| 5. Brake noise (1) (creak sound) | (1) Hardened or deteriorated lining | Replace the shoe assembly or pad. |
| | (2) Worn lining | Replace the shoe assembly or pad. |
| | (3) Loosened back plate or the support installing bolts | Retighten. |
| | (4) Loose wheel bearing | Retighten to normal tightening torque. |
| | (5) Dirty rotor | Clean the rotor, or clean and replace the brake assembly. |
| 6. Brake noise (2) (hissing sound) | (1) Worn lining | Replace the shoe assembly or pad. |
| | (2) Improper installed shoe or pad | Correct or replace the shoe assembly or pad. |
| | (3) Loose or bent rotor | Retighten or replace. |
| 7. Brake noise (3) (click sound) | (1) Excessively worn pad or the support | Replace the pad or the support. |
| | (2) Excessively worn shoe ridge | Replace the back plate. |
| | (3) Lack of oil on the shoe ridge surface and anchor | Add more grease. |