

# POWER ASSISTED SYSTEM (POWER STEERING)

# PS

---

	<b>Page</b>
1. General Description .....	2
2. Steering Wheel.....	18
3. Universal Joint.....	19
4. Tilt Steering Column.....	21
5. Steering Gearbox .....	24
6. Pipe Assembly .....	43
7. Oil Pump .....	51
8. Reservoir Tank.....	62
9. Power Steering Fluid.....	64
10. General Diagnostic Table.....	66



# GENERAL DESCRIPTION

## POWER ASSISTED SYSTEM (POWER STEERING)

### 1. General Description

#### A: SPECIFICATIONS

Model		Except OUTBACK	Pick-up	OUTBACK	
		Non-TURBO model	TURBO model	2.5 L model	3.0 L model
Whole system	Minimum turning radius	5.4±0.5 (17.7±1.6)	5.6±0.5 (18.4±1.6)	5.6±0.5 (18.4±1.6)	
	Steering angle (Inside — Outside)	36.3°±1.5° — 31.6°±1.5°	34.5°±1.5° — 30.3°±1.5°	34.5°±1.5° — 30.3°±1.5°	
	Steering wheel diameter	385 (15.16)			
	Overall gear ratio	16.5	19.0	19.0	
	Turns lock to lock	3.2	3.4	3.4	
Gearbox	Type	Rack and pinion, Integral			
	Backlash	0 (Automatically adjustable)			
	Valve (Power steering system)	Rotary valve			
Pump (Power steering system)	Type	Vane pump			
	Oil tank	Installed on body			
	Output	7.2 (0.439)	8.5 — 0.6 (0.582 — 0.037)	7.2 (0.439)	9.6 — 0.65 (0.586 — 0.040)
	Relief pressure	9,807 (100, 1,422)	7,846 (80, 1,138)	9,807 (100, 1,422)	7,846 (80, 1,138)
	Hydraulic fluid control	Dropping in response to increased engine revolutions			
	Hydraulic fluid	1,000 rpm: 6 (6.3, 5.3) 3,000 rpm: 5 (5.3, 4.4)	1,000 rpm: 7 (7.4, 6.2) 3,000 rpm: 5 (5.3, 4.4)	1,000 rpm: 7 (7.4, 6.2) 3,000 rpm: 5 (5.3, 4.4)	
	Range of revolution	500 — 9,000			500 — 8,000
	Revolving direction	Clockwise			
Working fluid (Power steering system)	Name	ATF DEXRON IIE or III			
	Capacity	Oil tank	0.3 (0.3, 0.3)		
		Total	0.7 (0.7, 0.6)		

# GENERAL DESCRIPTION

## POWER ASSISTED SYSTEM (POWER STEERING)

Steering wheel	Free play	mm (in)	17 (0.67)	
Turning angle	Inner tire & wheel	Except OUTBACK, Pick-up model	36.3°±1.5°	
		OUTBACK, Pick-up model	34.5°±1.5°	
	Outer tire & wheel	Except OUTBACK, Pick-up model	31.6°±1.5°	
		OUTBACK, Pick-up model	30.3°±1.5°	
Steering shaft	Clearance between steering wheel and column cover	mm (in)	3.0 (0.118)	
Steering gearbox (Power steering system)	Sliding resistance		N (kgf, lb)	304.0 (31.0, 68.4) or less
	Rack shaft play in radial direction	Right-turn steering	mm (in)	0.15 (0.0059) or less
		Left-turn steering	mm (in)	Horizontal movement: 0.3 (0.012) or less Vertical movement: 0.15 (0.0059) or less
	Input shaft play	In radial direction	mm (in)	0.18 (0.0071) or less
		In axial direction	mm (in)	0.1 (0.004) or less
	Turning resistance		N (kgf, lb)	Within 30 mm (1.18 in) from rack center in straight ahead position: Less than 11.18 (1.14, 2.51) Maximum allowable value: 12.7 (1.3, 2.9)
Oil pump (Power steering system)	Pulley shaft	Radial play	mm (in)	0.4 (0.016) or less
		Axial play	mm (in)	0.6 (0.024) or less
	Pulley	Ditch deflection	mm (in)	1.0 (0.039) or less
		Resistance to rotation	N (kgf, lb)	9.22 (0.94, 2.07) or less
	Regular pressure		kPa (kg/cm <sup>2</sup> , psi)	981 (10, 142) or less
	Relief pressure		kPa (kg/cm <sup>2</sup> , psi)	9,807 (100, 1,422)
Steering wheel effort (Power steering system)	At standstill with engine idling on a concrete road		N (kgf, lb)	29.4 (3.0, 6.6) or less
	At standstill with engine stalled on a concrete road		N (kgf, lb)	294.2 (30, 66.2) or less

Recommended power steering fluid	Manufacturer
ATF DEXRON III or equivalent	B.P.
	CALTEX
	CASTROL
	MOBIL
	SHELL
	TEXACO

## GENERAL DESCRIPTION

### POWER ASSISTED SYSTEM (POWER STEERING)

**CAUTION:**

**This table lists various clearances that must be correctly adjusted to ensure normal vehicle driving without interfering noise, or any other faults.**

Location	Minimum allowance	
	2.5 L model	3.0 L model
(1) Crossmember — Pipe	5 mm (0.20 in)	
(2) DOJ — Shaft or joint	14 mm (0.55 in)	
(3) DOJ — Valve housing	11 mm (0.43 in)	
(4) Pipe — Pipe	2 mm (0.08 in)	
(5) Stabilizer — Pipe	5 mm (0.20 in)	
(6) Exhaust pipe — Pipe	15 mm (0.59 in)	
(7) Exhaust pipe — Gearbox boot	15 mm (0.59 in)	
(8) Side frame — Hose A and B	15 mm (0.59 in)	
(9) Cruise control pump — Hose A and B	15 mm (0.59 in)	
(10) Pipe portion of hose A — Pipe portion of hose B	1.5 mm (0.059 in)	—
(11) AT cooling hose — Joint	20 mm (0.79 in)	—
(12) Pressure hose — Return hose	—	3.0 mm (0.12 in)

# GENERAL DESCRIPTION

## POWER ASSISTED SYSTEM (POWER STEERING)

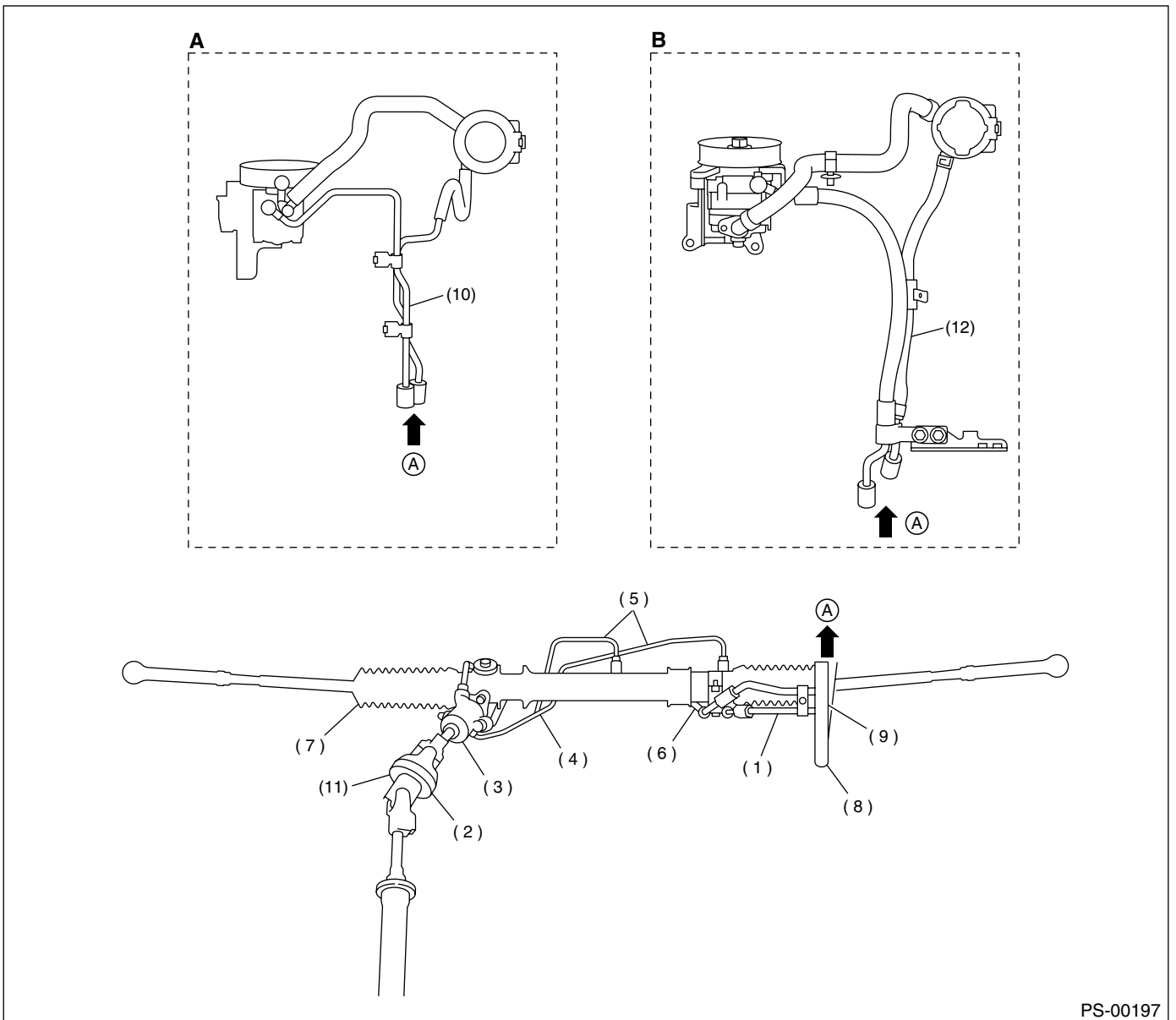

PS-00197

(A) 2.5 L model

(B) 3.0 L model

# GENERAL DESCRIPTION

POWER ASSISTED SYSTEM (POWER STEERING)

## B: COMPONENT

### 1. STEERING WHEEL AND COLUMN

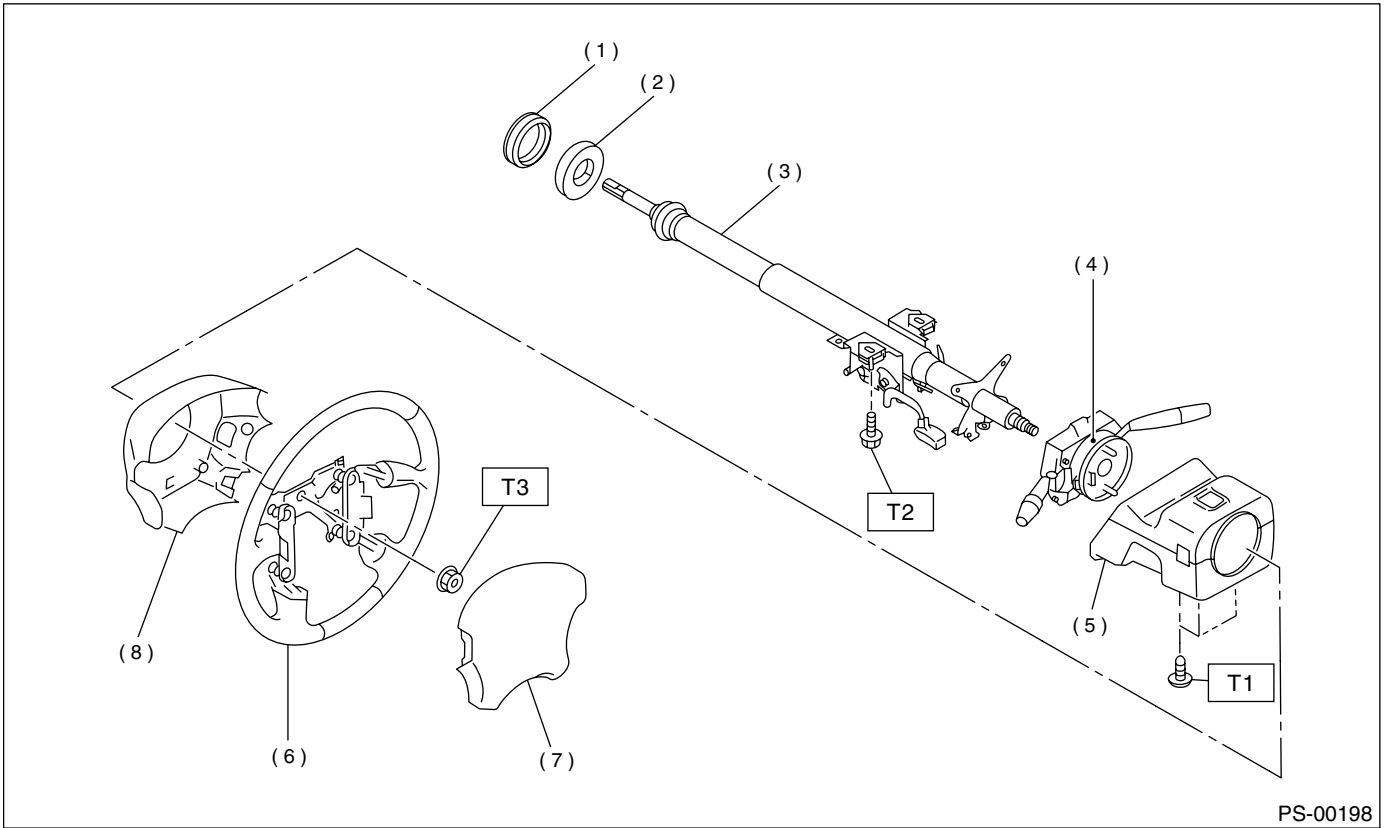

- |                             |                                |
|-----------------------------|--------------------------------|
| (1) Bushing                 | (6) Steering wheel             |
| (2) Seal                    | (7) Airbag module              |
| (3) Steering shaft          | (8) Lower steering wheel cover |
| (4) Steering roll connector |                                |
| (5) Column cover            |                                |

**Tightening torque: N-m (kgf-m, ft-lb)**

**T1: 1.2 (0.12, 0.9)**

**T2: 25 (2.5, 18.1)**

**T3: 44 (4.5, 32.5)**

# GENERAL DESCRIPTION

## POWER ASSISTED SYSTEM (POWER STEERING)

### 2. POWER ASSISTED SYSTEM

• Except TURBO model

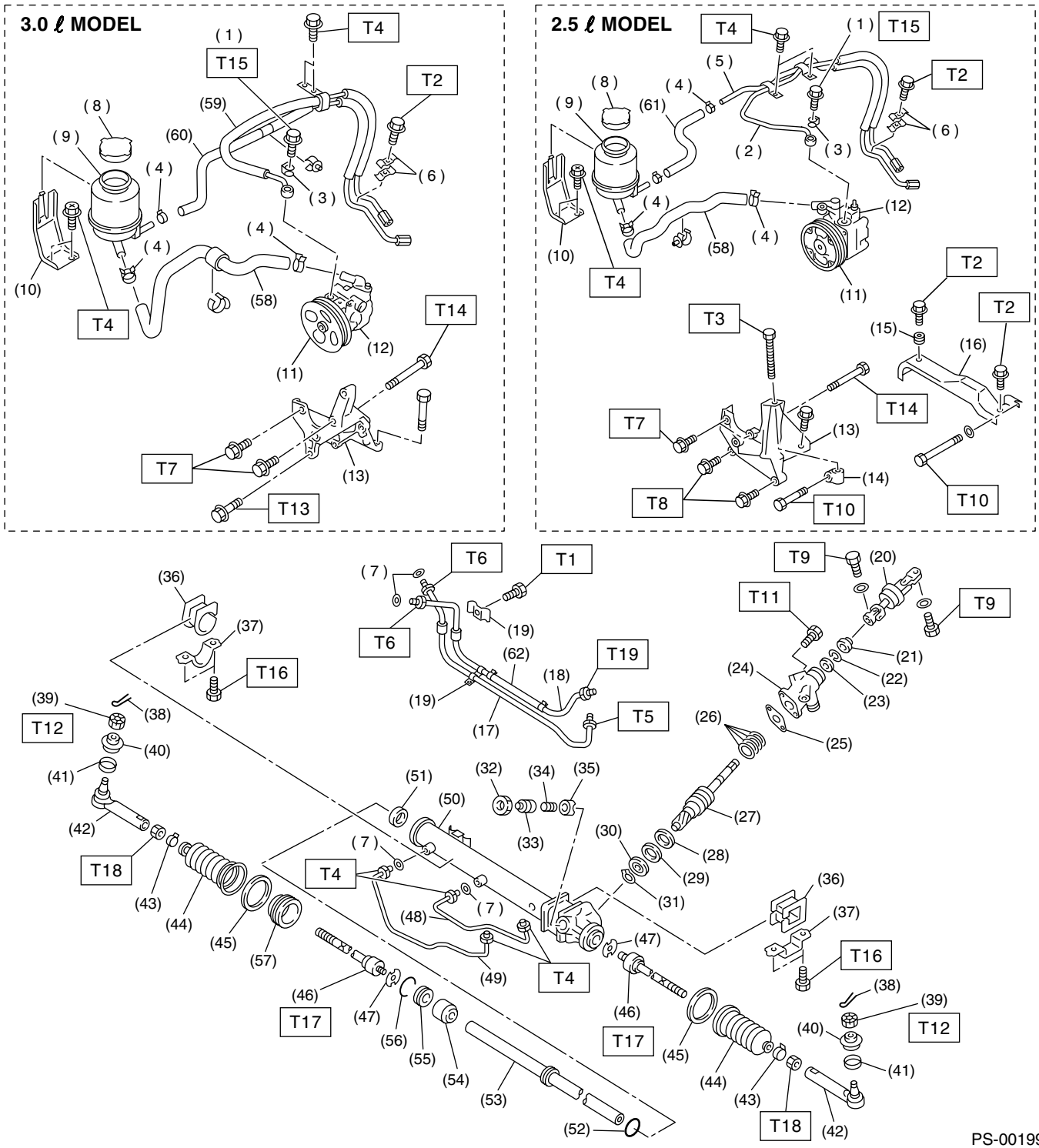

PS-00199

# GENERAL DESCRIPTION

## POWER ASSISTED SYSTEM (POWER STEERING)

### • TURBO model

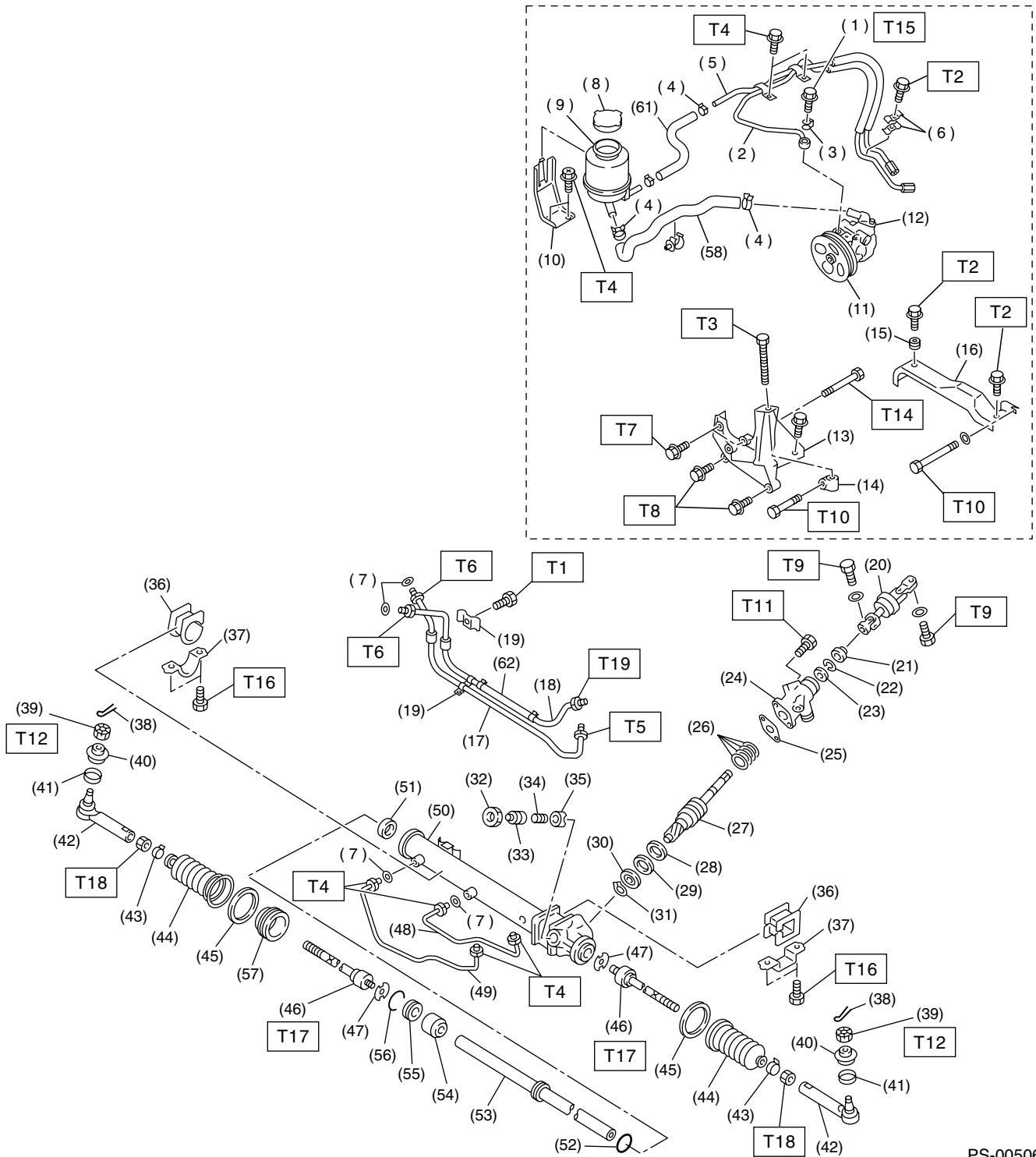

PS-00506



# GENERAL DESCRIPTION

## POWER ASSISTED SYSTEM (POWER STEERING)

(1) Eye bolt	(29) Back-up washer	(57) Spacer
(2) Pipe C	(30) Ball bearing	(58) Suction hose
(3) Gasket	(31) Snap ring	(59) Pressure hose ASSY
(4) Clip	(32) Lock nut	(60) Return hose ASSY
(5) Pipe D	(33) Adjusting screw	(61) Return hose
(6) Clamp E	(34) Spring	(62) Hose
(7) O-ring	(35) Sleeve	
(8) Cap	(36) Adapter	
(9) Reservoir tank	(37) Clamp	
(10) Reservoir tank bracket	(38) Cotter pin	
(11) Pulley	(39) Castle nut	
(12) Oil pump	(40) Dust cover	
(13) Bracket	(41) Clip	
(14) Belt tension nut	(42) Tie-rod end	
(15) Bushing	(43) Clip	
(16) Belt cover	(44) Boot	
(17) Pipe E	(45) Band	
(18) Pipe F	(46) Tie-rod	
(19) Clamp plate	(47) Lock washer	
(20) Universal joint	(48) Pipe B	
(21) Dust seal	(49) Pipe A	
(22) C-ring	(50) Steering body	
(23) Oil seal	(51) Oil seal	
(24) Valve housing	(52) Piston ring	
(25) Gasket	(53) Rack	
(26) Seal ring	(54) Rack bushing	
(27) Pinion and valve ASSY	(55) Rack stopper	
(28) Oil seal	(56) Circlip	

---

**Tightening torque: N-m (kgf-m, ft-lb)****T1: 6 (0.6, 4.3)****T2: 7.4 (0.75, 5.4)****T3: 8 (0.8, 5.8)****T4: 13 (1.3, 9.4)****T5: 15 (1.5, 10.8)****T6: 15 (1.5, 10.8)****T7: 15.7 (1.6, 11.6)****T8: 22 (2.2, 15.9)****T9: 24 (2.4, 17.4)****T10: 24.5 (2.5, 18.1)****T11: 25 (2.5, 18.1)****T12: 27 (2.75, 19.9)****T13: 33 (3.4, 25)****T14: 37.3 (3.8, 27.5)****T15: 39 (4.0, 28.9)****T16: 59 (6.0, 43)****T17: 78 (8.0, 58)****T18: 83 (8.5, 61.5)****T19: 25 (2.5, 18.1)**

---

# GENERAL DESCRIPTION

## POWER ASSISTED SYSTEM (POWER STEERING)

### 3. OIL PUMP

**NOTE:**

The illustration for 2.5 L Non-TURBO model is shown below. (Not shown for TURBO model and 3.0 L model because it cannot be disassembled.)

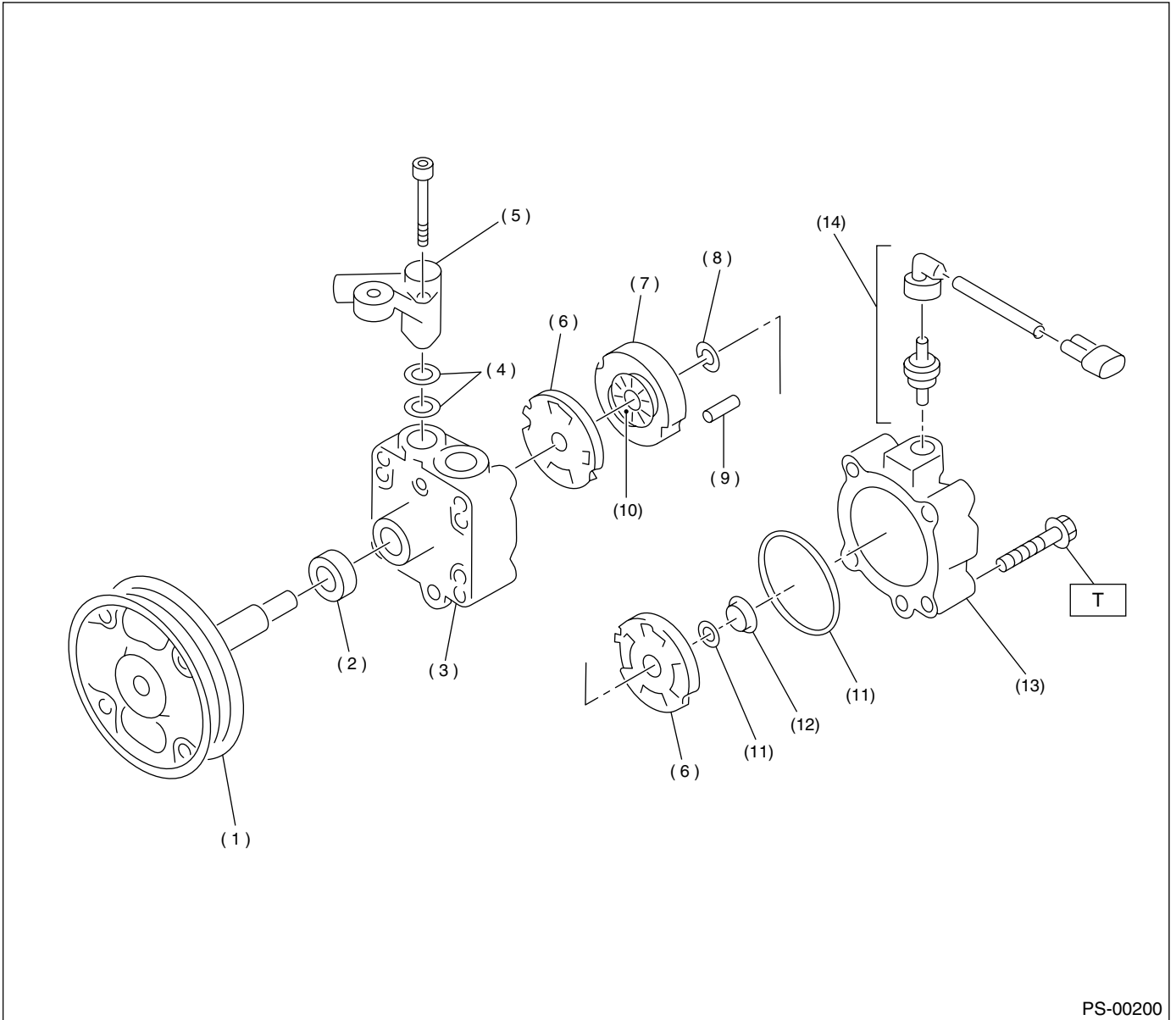

PS-00200

- (1) Pulley
- (2) Oil seal
- (3) Front casing
- (4) O-ring
- (5) Socket
- (6) Pressure plate

- (7) Cam ring
- (8) Circlip
- (9) Straight pin
- (10) Rotor
- (11) O-ring
- (12) Seal ring

- (13) Rear body
- (14) Connector

**Tightening torque: N·m (kgf·m, ft·lb)**

**T: 27.5 (2.8, 20.3)**

## GENERAL DESCRIPTION

### POWER ASSISTED SYSTEM (POWER STEERING)

---

#### **C: CAUTION**

- This section includes Airbag related repair works. For those corresponding to the repair procedures, read carefully CAUTION items in AB section before working and be sure to follow the instructions.
- Wear working clothing, including a cap, protective goggles, and protective shoes during operation.
- Remove contamination including dirt and corrosion before removal, installation or disassembly.
- Keep the disassembled parts in order and protect them from dust or dirt.
- Before removal, installation or disassembly, be sure to clarify the failure. Avoid unnecessary removal, installation, disassembly and replacement.
- Be careful not to burn your hands, because each part on the vehicle is hot after running.
- Use SUBARU genuine steering fluid, grease etc. or the equivalent. Do not mix steering fluid, grease etc. with that of another grade or from other manufacturers.
- Be sure to tighten fasteners including bolts and nuts to the specified torque.
- Place shop jacks or safety stands at the specified points.
- Apply steering fluid onto sliding or revolution surfaces before installation.
- Before installing O-rings or snap rings, apply sufficient amount of steering fluid to avoid damage and deformation.
- Before securing a part on a vise, place cushioning material such as wood blocks, aluminum plate, or shop cloth between the part and the vise.

# GENERAL DESCRIPTION

POWER ASSISTED SYSTEM (POWER STEERING)

## D: PREPARATION TOOL

### 1. SPECIAL TOOLS

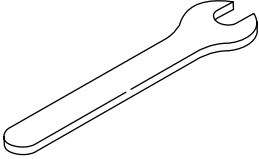
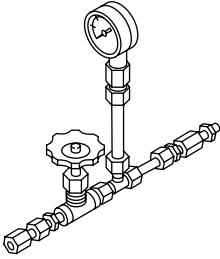
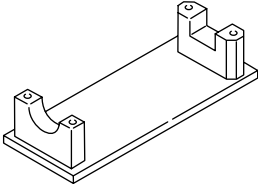
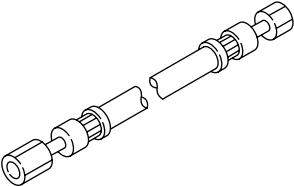
ILLUSTRATION	TOOL NUMBER	DESCRIPTION	REMARKS
 ST-925700000	925700000	WRENCH	<ul style="list-style-type: none"><li>Used for removing and installing tie-rod.</li><li>Apply this tool to rack.</li></ul>
 ST-925711000	925711000	PRESSURE GAUGE	Used for measuring oil pump pressure.
 ST-926200000	926200000	STAND	Used when inspecting characteristic of gearbox assembly and disassembling it.
 ST34099AC010	34099AC010	ADAPTER HOSE A	Used with PRESSURE GAUGE (925711000).

# GENERAL DESCRIPTION

## POWER ASSISTED SYSTEM (POWER STEERING)

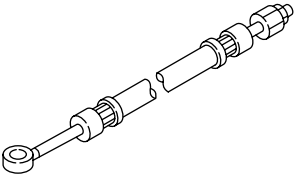
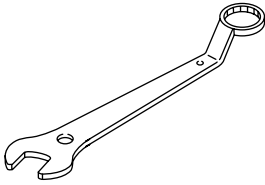
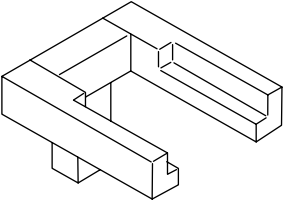
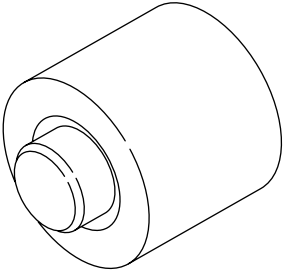
ILLUSTRATION	TOOL NUMBER	DESCRIPTION	REMARKS
 <p style="text-align: center;">ST34099AC020</p>	34099AC020	ADAPTER HOSE B	Used with PRESSURE GAUGE (925711000).
 <p style="text-align: center;">ST-926230000</p>	926230000	SPANNER	<ul style="list-style-type: none"> <li>• For the lock nut when adjusting backlash of gearbox.</li> <li>• Measurement of rotating resistance of gearbox assembly.</li> </ul>
 <p style="text-align: center;">ST34199AE020</p>	34199AE020	MOUNT	Used for disassembling oil pump.
 <p style="text-align: center;">ST34199AE030</p>	34199AE030	INSTALLER	Used for installing oil seal into oil pump.

# GENERAL DESCRIPTION

## POWER ASSISTED SYSTEM (POWER STEERING)

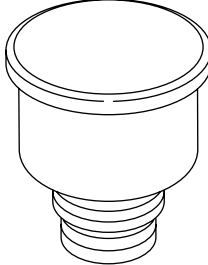
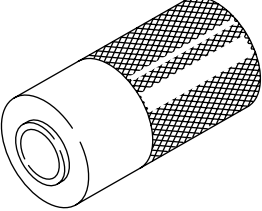
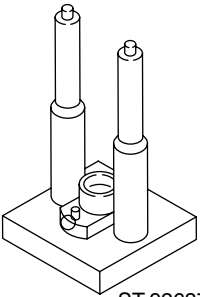
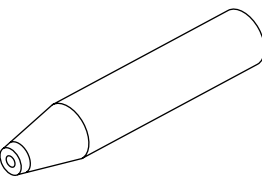
ILLUSTRATION	TOOL NUMBER	DESCRIPTION	REMARKS
 <p style="text-align: center;">ST34199AE040</p>	34199AE040	OIL CHARGE GUIDE	Used for charging power steering oil.
 <p style="text-align: center;">ST-927640000</p>	927640000	INSTALLER B	Used for installing ball bearing into housing.
 <p style="text-align: center;">ST-926370000</p>	926370000	INSTALLER A	<ul style="list-style-type: none"> <li>• Used for installing valve assembly into valve housing assembly.</li> <li>• Used with STAND BASE (927630000).</li> </ul>
 <p style="text-align: center;">ST-926390001</p>	926390001	COVER & REMOVER ASSY	Used for assembling rack assembly.

# GENERAL DESCRIPTION

## POWER ASSISTED SYSTEM (POWER STEERING)

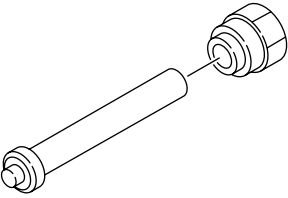
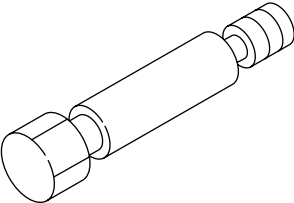
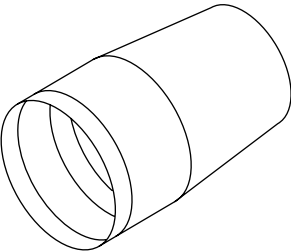
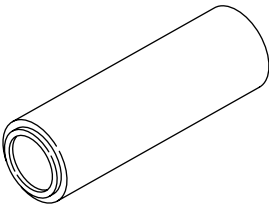
ILLUSTRATION	TOOL NUMBER	DESCRIPTION	REMARKS
 <p style="text-align: center;">ST-926420000</p>	926420000	PLUG	<p>When oil leaks from pinion side of gearbox assembly, remove pipe B from valve housing, attach this tool and check oil leaking points.</p>
 <p style="text-align: center;">ST-926400000</p>	926400000	GUIDE	<ul style="list-style-type: none"> <li>• Right side of rack when installing rack bushing.</li> <li>• Used with GUIDE (927660000).</li> </ul>
 <p style="text-align: center;">ST-927660000</p>	927660000	GUIDE	<ul style="list-style-type: none"> <li>• Right side of rack when installing rack bushing.</li> <li>• Used with GUIDE (926400000).</li> </ul>
 <p style="text-align: center;">ST-927620000</p>	927620000	INSTALLER B	<ul style="list-style-type: none"> <li>• Used for installing oil seal of valve housing.</li> <li>• Used with INSTALLER A (926360000).</li> </ul>

# GENERAL DESCRIPTION

## POWER ASSISTED SYSTEM (POWER STEERING)

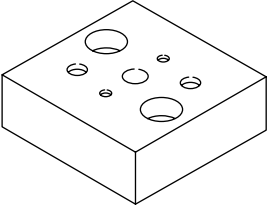
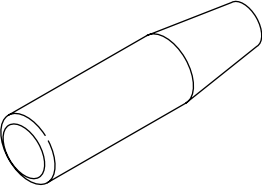
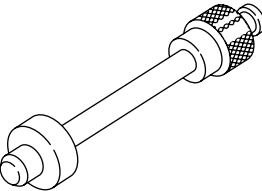
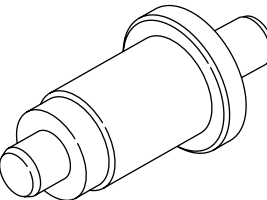
ILLUSTRATION	TOOL NUMBER	DESCRIPTION	REMARKS
 <p style="text-align: center;">ST-927630000</p>	927630000	STAND BASE	Used for assembling power steering gearbox.
 <p style="text-align: center;">ST-926360000</p>	926360000	INSTALLER A	<ul style="list-style-type: none"> <li>• Used as a guide to install oil seal.</li> <li>• Used with INSTALLER B (927620000).</li> </ul>
 <p style="text-align: center;">ST34199AE060</p>	34199AE060	INSTALLER	Used for installing oil seal.
 <p style="text-align: center;">ST-927610000</p>	927610000	INSTALLER & REMOVER SEAL	Used for installing valve housing oil seal.



# GENERAL DESCRIPTION

POWER ASSISTED SYSTEM (POWER STEERING)

---

## 2. GENERAL PURPOSE TOOLS

TOOL NAME	REMARKS
Spring scale	Used for measuring tightening torque.
Snap ring pliers	Used for removing and installing snap ring.
Dial gauge	Used for measuring steering gearbox.

# STEERING WHEEL

## POWER ASSISTED SYSTEM (POWER STEERING)

### 2. Steering Wheel

#### A: REMOVAL

- 1) Disconnect ground cable from battery.
- 2) Set tires to straight-ahead position.
- 3) Remove airbag module. <Ref. to AB-13, REMOVAL, Driver's Airbag Module.>

#### WARNING:

Always refer to "Airbag System" before performing airbag module service (if so equipped). <Ref. to AB-13, INSPECTION, Driver's Airbag Module.>

- 4) Remove steering wheel nut, and then draw out steering wheel from shaft using steering puller.

#### NOTE:

Make matching marks on steering wheel and steering column in advance.

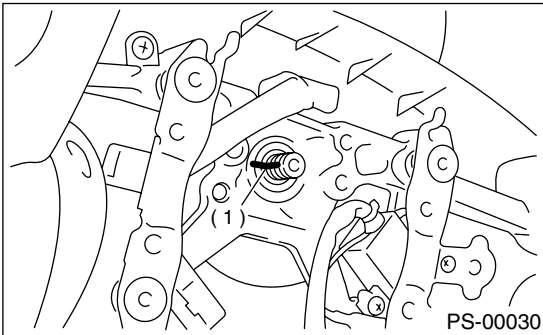

(1) Matching mark

#### B: INSTALLATION

- 1) Align center of roll connector. <Ref. to AB-20, ADJUSTMENT, Roll Connector.>
- 2) Install in the reverse order of removal.

#### NOTE:

Align matching marks on steering wheel and steering column.

#### Tightening torque:

**4.5 N·m (4.5 kgf·m, 32.5 ft·lb)**

#### Column cover-to-steering wheel clearance:

**2 — 4 mm (0.08 — 0.16 in)**

#### WARNING:

Always refer to "Airbag System" before performing airbag module service (if so equipped). <Ref. to AB-13, INSPECTION, Driver's Airbag Module.>

#### CAUTION:

Insert roll connector guide pin into guide hole on lower end of surface of steering wheel to prevent damage. Draw out airbag system connector, horn connector and cruise control con-

nectors from guide hole of steering wheel lower end.

#### C: INSPECTION

- 1) Check steering wheel for deformation. If the deformation is excessive, replace steering wheel.
- 2) Check splines on steering wheel for damage. If the damage is excessive, replace steering wheel.

# UNIVERSAL JOINT

POWER ASSISTED SYSTEM (POWER STEERING)

## 3. Universal Joint

### A: REMOVAL

- 1) Set the vehicle on a lift.
- 2) Remove the steering wheel. <Ref. to PS-18, REMOVAL, Steering Wheel.>
- 3) Lift-up the vehicle.
- 4) Remove universal joint bolts and then remove universal joint.

#### CAUTION:

**Scribe alignment marks on universal joint so that it can be reassembled at the original serration.**

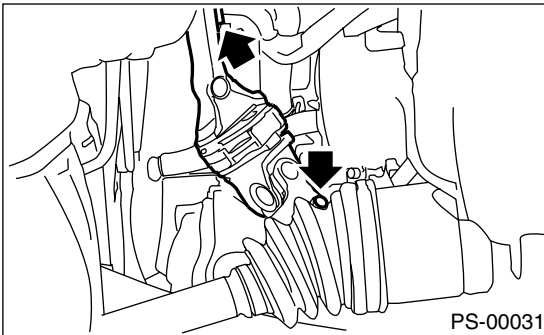

### B: INSTALLATION

- 1) Install universal joint.
  - (1) Align bolts hole on the long yoke side of universal joint with the cutout at the serrated section of shaft end, and insert universal joint.
  - (2) Align bolt hole on the short yoke side of universal joint with the cutout at the serrated section of gearbox assembly. Lower universal joint completely.
  - (3) Temporarily tighten bolt on the short yoke side. Raise universal joint to make sure the bolt is properly passing through the cutout at the serrated section.
  - (4) Tighten bolt on the long yoke, then that on the short yoke side.

#### Tightening torque:

**24 N·m (2.4 kgf-m, 17.4 ft-lb)**

#### CAUTION:

- Make sure that universal joint bolt is tightened through notch in shaft serration.
- Excessively large tightening torque of universal joint bolts may lead to heavy steering wheel operation.

#### Standard clearance between gearbox to DOJ:

**Over 15 mm (0.59 in)**

- 2) Lower the vehicle.
- 3) Align center of roll connector. <Ref. to AB-20, ADJUSTMENT, Roll Connector.>

#### CAUTION:

**Ensure that front wheel are set straight forward direction.**

- 4) Install steering wheel and airbag module. <Ref. to PS-18, INSTALLATION, Steering Wheel.>

#### WARNING:

**Always refer to “Airbag System” before performing airbag module service (if so equipped). <Ref. to AB-13, INSPECTION, Driver’s Airbag Module.> and <Ref. to AB-13, INSTALLATION, Driver’s Airbag Module.>**

# UNIVERSAL JOINT

## POWER ASSISTED SYSTEM (POWER STEERING)

### C: INSPECTION

Clean the disassembled parts with a cloth, and check for wear, damage, or any other faults. If necessary, repair or replace faulty parts.

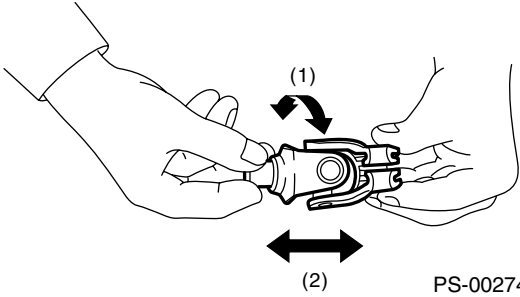
Inspection	Corrective action
<p>(1) Free play (2) Swinging torque Yawing torque Looseness</p>  <p style="text-align: right;">PS-00274</p> <p><b>Standard value of universal joint free play: 0 mm (0 in)</b> <b>Max. value of universal joint swinging torque: 0.3 N-m (0.03 kgf-m, 0.2 ft-lb)</b></p>	<p>Replace if faulty.</p>

Measurement of folding torque of universal joint is as shown in the figures.

**Service limit:**

**Maximum load; 5.49 N (0.56 kgf, 1.23 lb) or less**

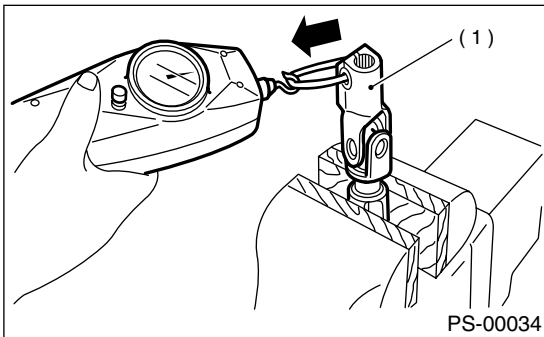

(1) Long yoke

**Service limit:**

**Maximum load; 5.49 N (0.56 kgf, 1.23 lb) or less**

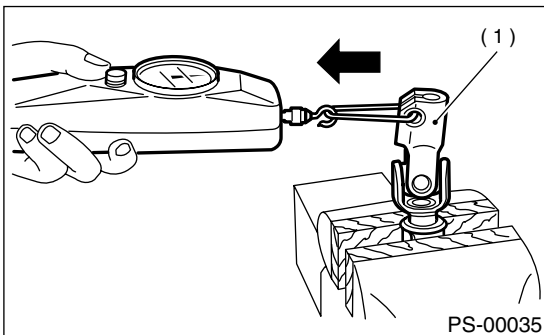

(1) Long yoke

**Service limit:**

**Maximum load; 8.43 N (0.86 kgf, 1.90 lb) or less**

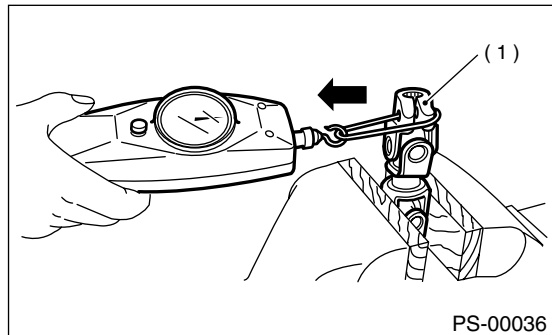

(1) Short yoke

**Service limit:**

**Maximum load; 8.43 N (0.86 kgf, 1.90 lb) or less**

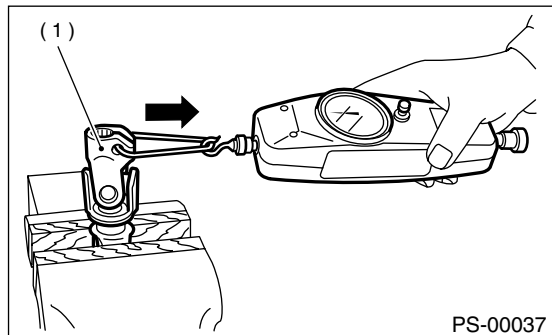

(1) Short yoke

# TILT STEERING COLUMN

POWER ASSISTED SYSTEM (POWER STEERING)

## 4. Tilt Steering Column

### A: REMOVAL

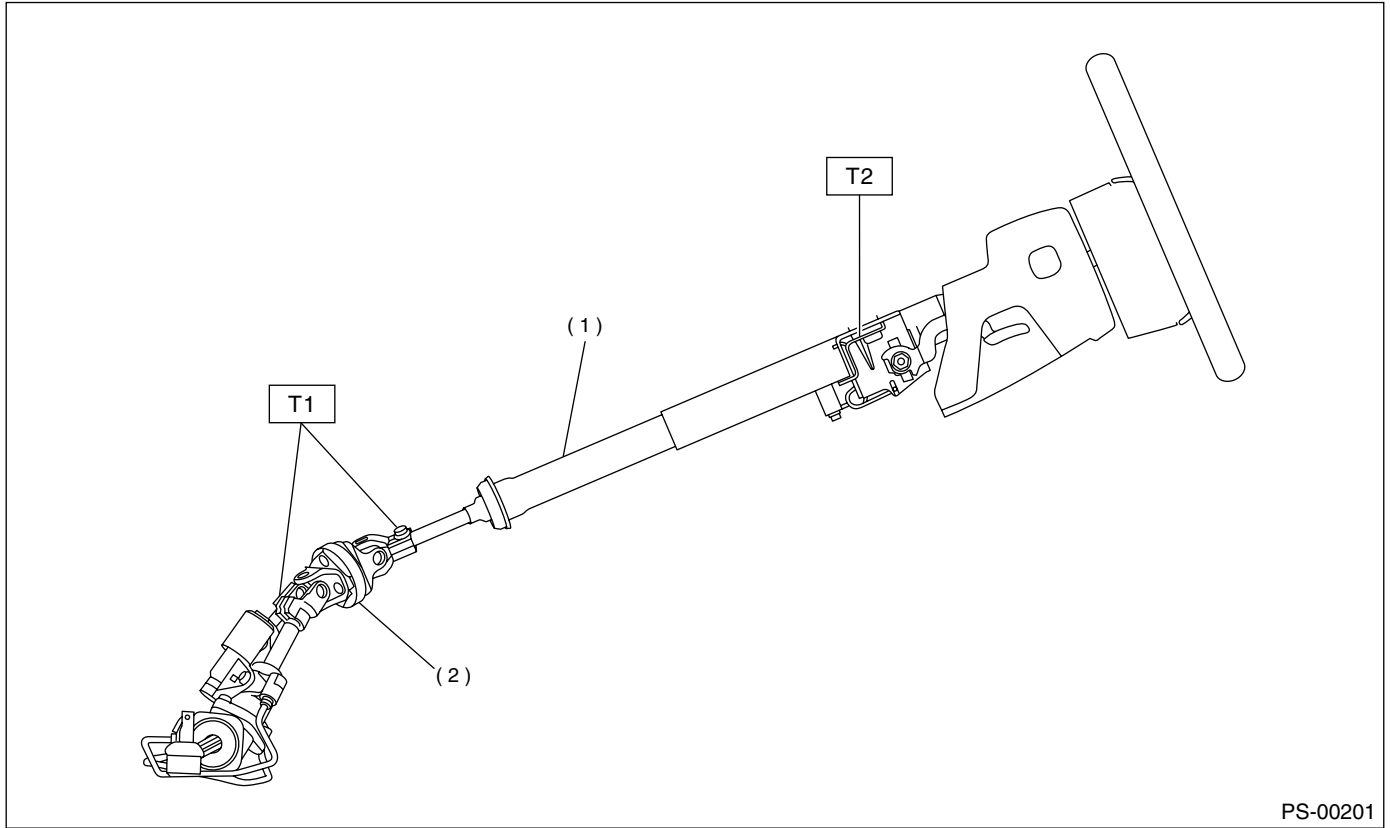

PS-00201

- (1) Tilt steering column
- (2) Universal joint

---

**Tightening torque: N·m (kgf-m, ft-lb)**

**T1: 24 (2.4, 17.4)**

**T2: 25 (2.5, 18.1)**

---

# TILT STEERING COLUMN

## POWER ASSISTED SYSTEM (POWER STEERING)

- 1) Set the vehicle on the lift.
- 2) Disconnect battery minus ground cable.
- 3) Remove airbag module. <Ref. to AB-13, REMOVAL, Driver's Airbag Module.>

### WARNING:

Always refer to "Airbag System" before performing airbag module service (if so equipped). <Ref. to AB-13, INSPECTION, Driver's Airbag Module.>

- 4) Remove steering wheel. <Ref. to PS-18, REMOVAL, Steering Wheel.>
- 5) Lift-up the vehicle.
- 6) Remove universal joint. <Ref. to PS-19, REMOVAL, Universal Joint.>
- 7) Lower the vehicle.
- 8) Remove trim panel under instrument panel.
- 9) Remove the screw securing lower steering column cover.

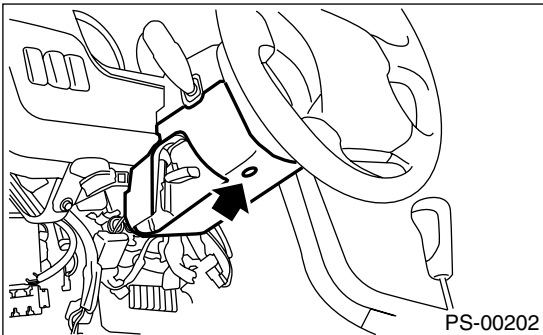

- 10) Remove all connectors from steering column.
- 11) Remove the two bolts under instrument panel securing steering column.

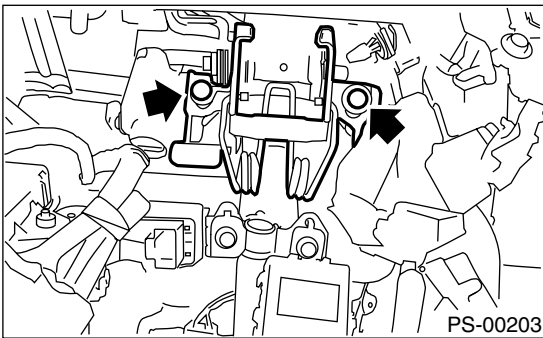

- 12) Pull out steering shaft assembly from hole on toe board.

### CAUTION:

Be sure to remove universal joint before removing steering shaft assembly installing bolts when removing steering shaft assembly or when lowering it for servicing of other parts.

## B: INSTALLATION

- 1) Set grommet to toe board.

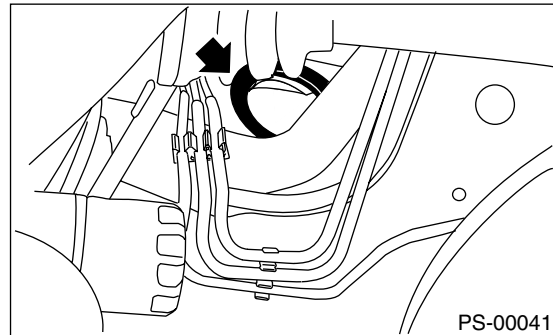

- 2) Insert end of steering shaft into toe board grommet.
- 3) Tighten steering shaft mounting bolts under instrument panel.

### Tightening torque:

**25 N·m (2.5 kgf·m, 18.1 ft·lb)**

- 4) Connect all connectors under instrument panel.
- 5) Connect airbag system connector at harness spool.

### NOTE:

Make sure to apply double lock.

- 6) Install lower column cover with tilt lever held in the lowered position.
- 7) Install universal joint. <Ref. to PS-19, INSTALLATION, Universal Joint.>
- 8) Align center of roll connector. <Ref. to AB-20, ADJUSTMENT, Roll Connector.>

### CAUTION:

Ensure that front wheels are set in straight forward direction.

- 9) Install steering wheel. <Ref. to PS-18, INSTALLATION, Steering Wheel.>  
Set steering wheel to neutral and install it onto steering shaft.

### CAUTION:

Insert roll connector guide pin into guide hole on lower end of surface of steering wheel to prevent damage. Draw out airbag system connector, horn connector and cruise control connectors from guide hole of steering wheel lower end.

- 10) Install airbag module to steering wheel.

### WARNING:

Always refer to "Airbag System" before performing the service operation. <Ref. to AB-13, INSPECTION, Driver's Airbag Module.>

# TILT STEERING COLUMN

POWER ASSISTED SYSTEM (POWER STEERING)

## C: DISASSEMBLY

Remove the two screws securing upper steering column covers, and the two screws securing combination switch, then remove related parts.

## D: ASSEMBLY

1) Insert combination switch to upper column shaft, and install upper column cover. Then route ignition key harness and combination switch harness between column cover mounting bosses.

### *Tightening torque:*

**1.2 N·m (0.12 kgf-m, 0.9 ft-lb)**

### **CAUTION:**

**Don't overtorque screw.**

## E: INSPECTION

### 1. BASIC INSPECTION

Measure overall length of steering column and if it is out of standard value, replace it.

#### *Standard value:*

##### *Overall length (L)*

**Except OUTBACK model:  $849^{+1.5}/_{-0.5}$  mm**

**( $33.425^{+0.059}/_{-0.020}$  in)**

**OUTBACK model:  $817^{+1.5}/_{-0.5}$  mm ( $32.197$**

**$+0.059}/_{-0.020}$  in)**

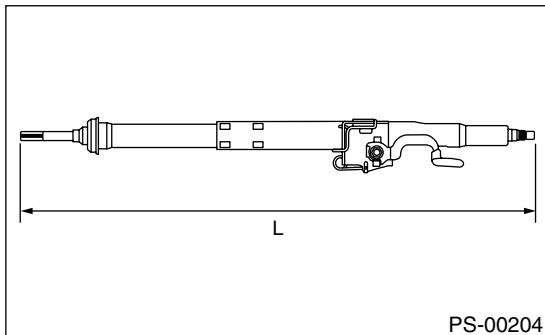

PS-00204

### 2. AIRBAG MODEL INSPECTION

#### **WARNING:**

For airbag model inspection procedures, refer to "Airbag System". <Ref. to AB-13, INSPECTION, Driver's Airbag Module.>

# STEERING GEARBOX

## POWER ASSISTED SYSTEM (POWER STEERING)

### 5. Steering Gearbox

#### A: REMOVAL

- 1) Disconnect battery ground cable.
- 2) Loosen front wheel nut.
- 3) Lift vehicle and remove front wheels.
- 4) Remove front exhaust pipe assembly.

#### 2.5 L model

<Ref. to EX(H4SO)-5, REMOVAL, Front Exhaust Pipe.>

#### 3.0 L model

<Ref. to EX(H6DO)-5, REMOVAL, Front Exhaust Pipe.>

#### WARNING:

Be careful, exhaust pipe is hot.

- 5) Using a puller, remove tie-rod end from knuckle arm after pulling off cotter pin and removing castle nut.

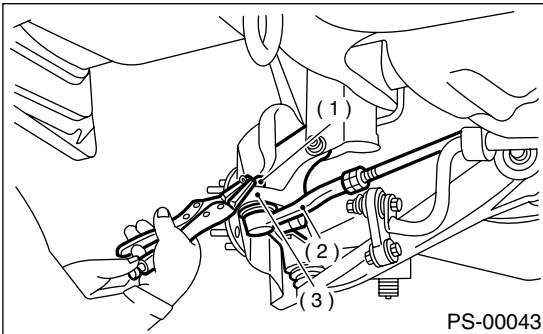

- (1) Castle nut
- (2) Tie-rod end
- (3) Knuckle arm

- 6) Remove jack-up plate and front stabilizer. <Ref. to FS-22, REMOVAL, Front Stabilizer.>

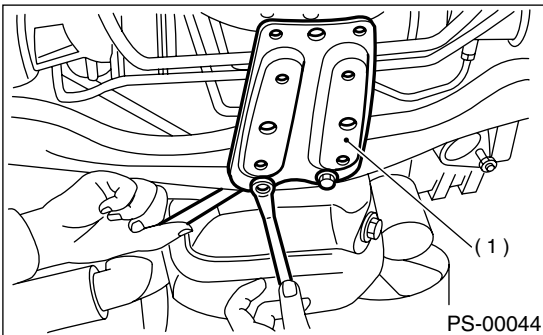

- (1) Jack-up plate

- 7) Remove one pipe joint at the center of gearbox, and connect vinyl hose to pipe and joint. Discharge fluid by turning steering wheel fully clockwise and counterclockwise. Discharge fluid similarly from the other pipe.

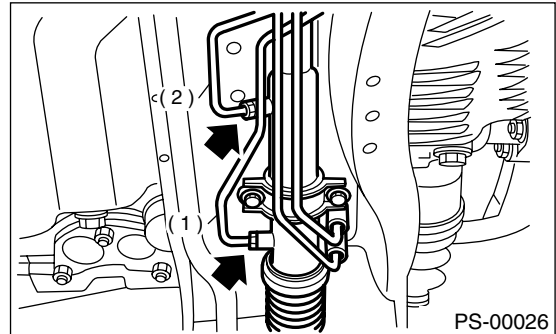

- (1) Pipe A
- (2) Pipe B

- 8) Remove universal joint. <Ref. to PS-19, REMOVAL, Universal Joint.>

- 9) Disconnect pipes C (Pressure pipe assembly) and D (Return pipe assembly) from pipe of gearbox.

#### CAUTION:

Be careful not to damage these pipes.

#### NOTE:

Disconnect upper pipe D (Return hose assembly) first, and lower pipe C (Pressure hose assembly) second.

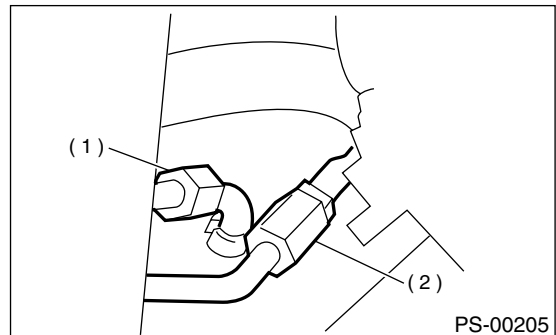

- (1) Pipe C
- (2) Pipe D



# STEERING GEARBOX

POWER ASSISTED SYSTEM (POWER STEERING)

10) Remove clamp bolts securing gearbox to crossmember, and remove gearbox.

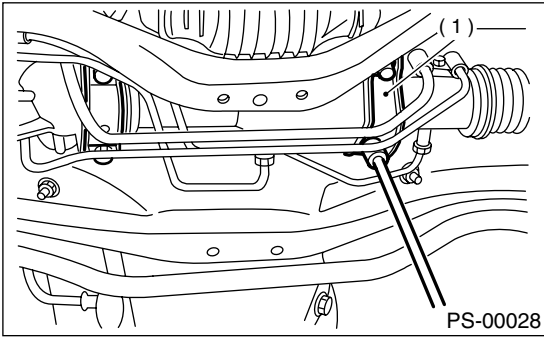

(1) Clamp

## B: INSTALLATION

- 1) Insert gearbox into crossmember, being careful not to damage gearbox boot.
- 2) Tighten gearbox to crossmember bracket via clamp with bolt to the specified torque.

### Tightening torque:

**59 N·m (6.0 kgf-m, 43 ft-lb)**

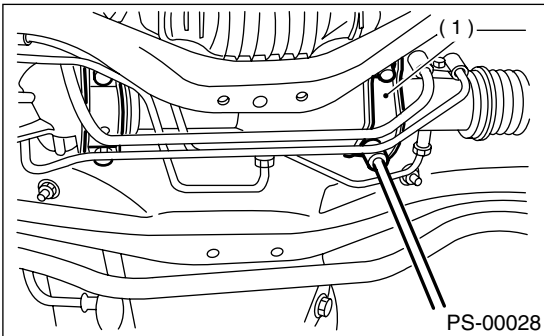

(1) Clamp

3) Connect pipes C and D to pipe of gearbox.

### NOTE:

Connect lower pipe C first, and upper pipe D second.

### CAUTION:

Be careful not to damage these pipes.

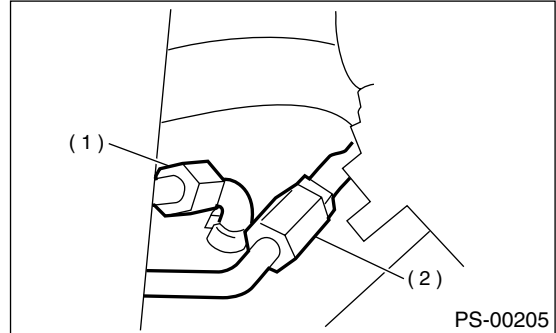

(1) Pipe C  
(2) Pipe D

4) Install universal joint. <Ref. to PS-19, INSTALLATION, Universal Joint.>

5) Connect tie-rod end and knuckle arm, and tighten with castle nut. Fit cotter pin into the nut and bend the pin to lock.

### Castle nut tightening torque:

**Tighten to 27.0 N·m (2.75 kgf-m, 19.9 ft-lb), and tighten further within 60° until cotter pin hole is aligned with a slot in the nut.**

### CAUTION:

When connecting, do not hit cap at the bottom of tie-rod end with hammer.

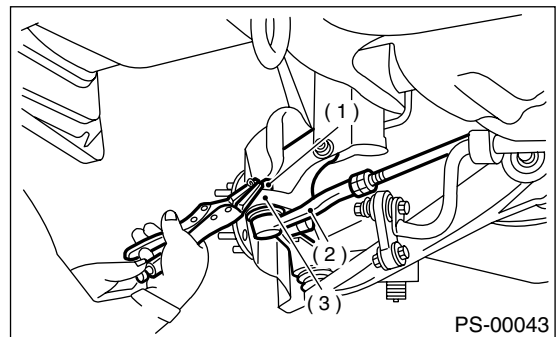

(1) Castle nut  
(2) Tie-rod end  
(3) Knuckle arm

6) Install front stabilizer to vehicle. <Ref. to FS-22, INSTALLATION, Front Stabilizer.>

# STEERING GEARBOX

## POWER ASSISTED SYSTEM (POWER STEERING)

7) Install front exhaust pipe assembly. <Ref. to EX(H4SO)-6, INSTALLATION, Front Exhaust Pipe.>

### 2.5 L model

<Ref. to EX(H4SO)-6, INSTALLATION, Front Exhaust Pipe.>

### 3.0 L model

<Ref. to EX(H6DO)-6, INSTALLATION, Front Exhaust Pipe.>

8) Install tires.

9) Tighten wheel nuts to the specified torque.

### Tightening torque:

**88 N·m (9.0 kgf-m, 65 ft-lb)**

10) Connect battery ground cable.

11) Pour fluid into oil tank, and bleed air.

<Ref. to PS-64, Power Steering Fluid.>

12) Check for fluid leaks. <Ref. to PS-41, OIL LEAKING, INSPECTION, Steering Gearbox.>

13) Install jack-up plate.

### WARNING:

**Be careful, exhaust manifold is hot.**

14) Lower vehicle.

15) Check fluid level in oil tank.

16) After adjusting toe-in and steering angle, tighten lock nut on tie-rod end.

### Tightening torque:

**83 N·m (8.5 kgf-m, 61.5 ft-lb)**

### CAUTION:

**When adjusting toe-in, hold boot as shown to prevent it from being rotated or twisted. If twisted, straighten it.**

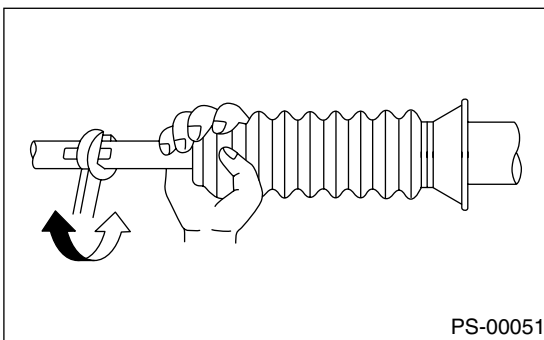

## C: DISASSEMBLY

### 1. RACK HOUSING ASSEMBLY

1) Disconnect four pipes from gearbox.

2) Secure gearbox removed from vehicle in vise using ST.

ST 92620000 STAND

### CAUTION:

**Secure the gearbox in a vise using the ST as shown. Do not attempt to secure it without this ST.**

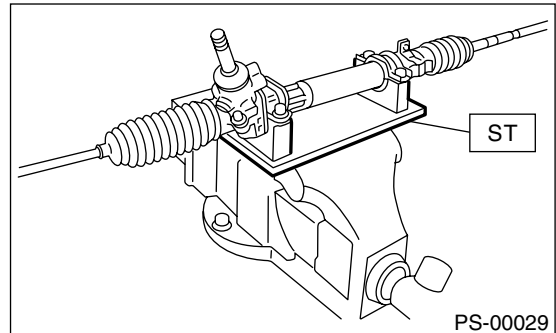

3) Remove tie-rod end and lock nut from gearbox.

4) Remove small clip from boot using pliers, and move boot to tie-rod end side.

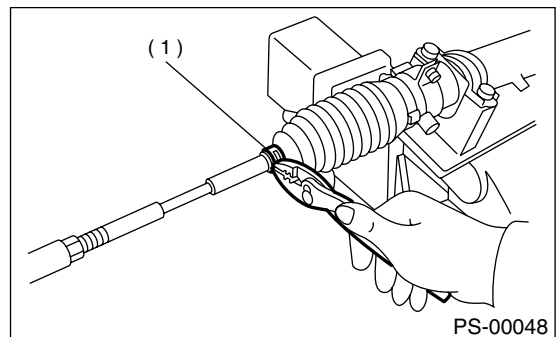

(1) Clip

5) Remove boot with large clips.

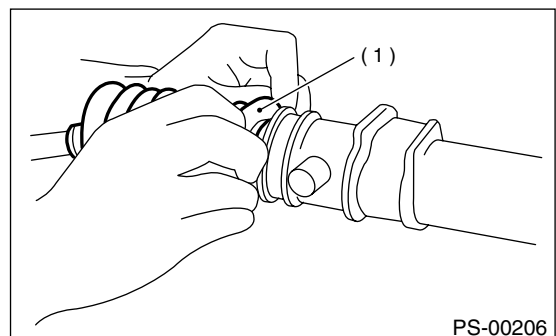

(1) Boot

# STEERING GEARBOX

POWER ASSISTED SYSTEM (POWER STEERING)

6) Extend rack approximately 40 mm (1.57 in) out. Unlock lock wire at lock washer on each side of tie-rod end using a standard screwdriver.

**CAUTION:**

Be careful not to scratch rack surface as oil leaks may result.

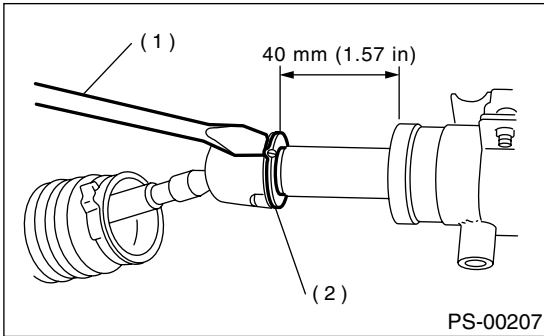

- (1) Standard screwdriver
- (2) Lock washer

7) Using ST, loosen lock nut.  
ST 926230000 SPANNER

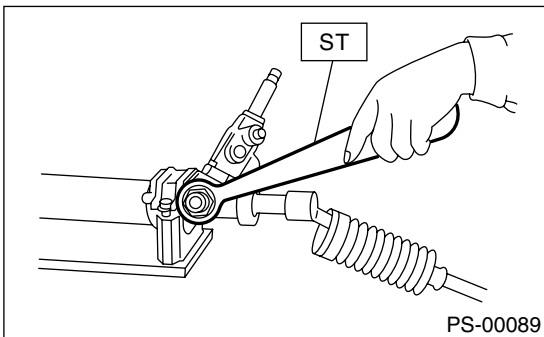

8) Tighten adjusting screw until it no longer tightens.

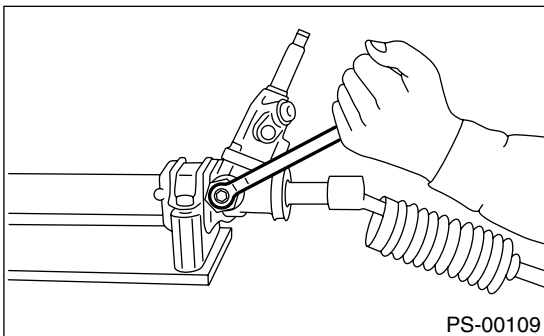

9) Using a wrench [32 mm (1.26 in) width across flats] or adjustable wrench, remove tie-rod.

**CAUTION:**

- Check ball joint for free play, and tie-rod for bends. Replace if necessary.
- Check dust seals used with tie-rod end ball joint for damage or deterioration. Replace if necessary.

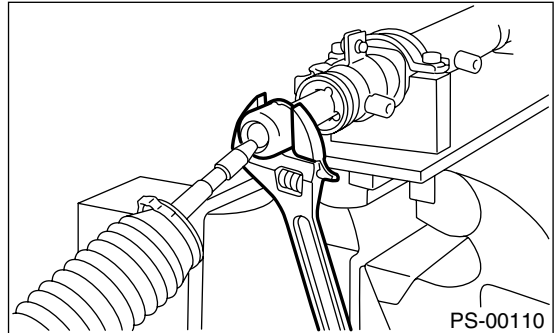

10) Loosen adjusting screw and remove spring and sleeve.

**CAUTION:**

Replace spring and/or sleeve if damaged.

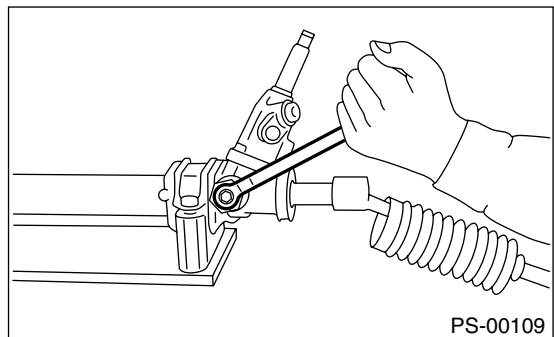

11) Remove two bolts securing valve assembly.

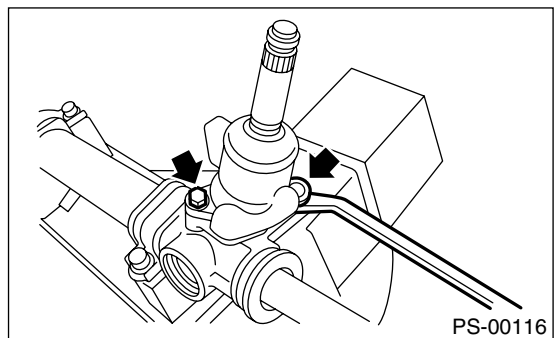

# STEERING GEARBOX

## POWER ASSISTED SYSTEM (POWER STEERING)

12) Carefully draw out input shaft and remove valve assembly.

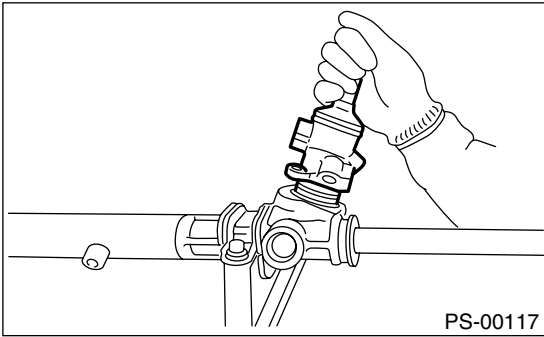

13) Using a sharp pointed pliers, rotate the rack stopper in the direction of the arrow until the end of the circlip comes out of the stopper. Rotate the circlip in the opposite direction and pull it out.

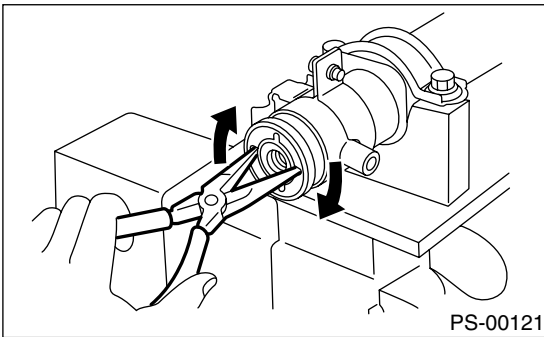

14) Pull rack assembly from cylinder side, and draw out rack bushing and rack stopper together with rack assembly.

### CAUTION:

Be careful not to contact rack to inner wall of cylinder when drawing out. Any scratch on cylinder inner wall will cause oil leakage.

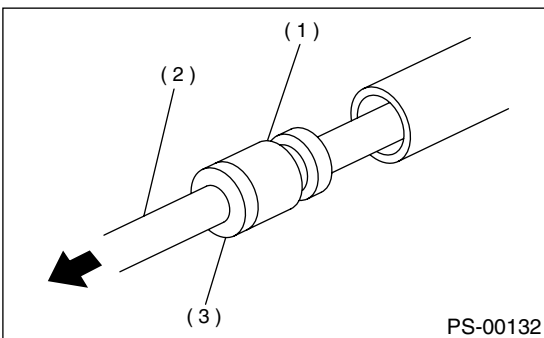

- (1) Rack bushing
- (2) Rack ASSY
- (3) Rack stopper

15) Remove rack bushing and rack stopper from rack assembly.

### CAUTION:

Do not reuse removed rack bushing and circlip.

16) Insert ST from pinion housing side and remove oil seal using a press.

ST 34199AE050 OIL SEAL REMOVER

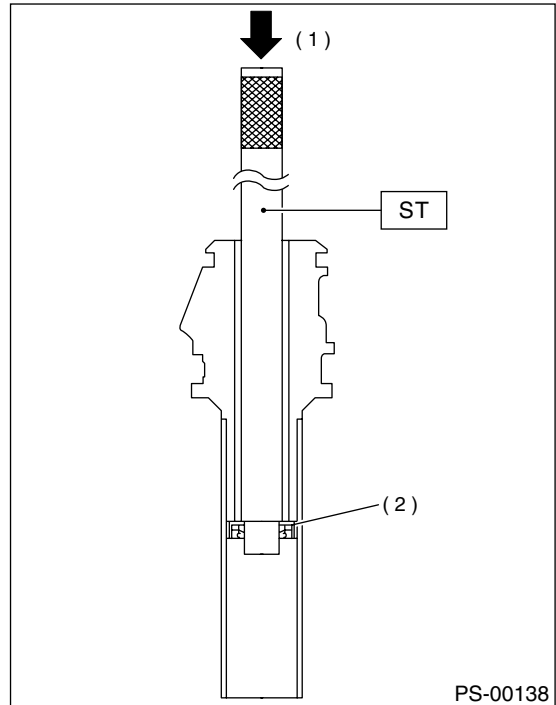

- (1) Press
- (2) Oil seal

### NOTE:

Discard removed oil seal.

## 2. CONTROL VALVE ASSEMBLY

### NOTE:

Parts requiring replacement are described in the smallest unit of spare parts including damaged parts and spare parts damaged. In actual disassembly work, accidental damage as well as inevitable damage to some related parts must be taken into account, and spare parts for them must also be prepared. However, it is essential to pinpoint the cause of trouble, and limit the number of replacement parts as much as possible.

1) Using ST, loosen lock nut.

ST 926230000 SPANNER

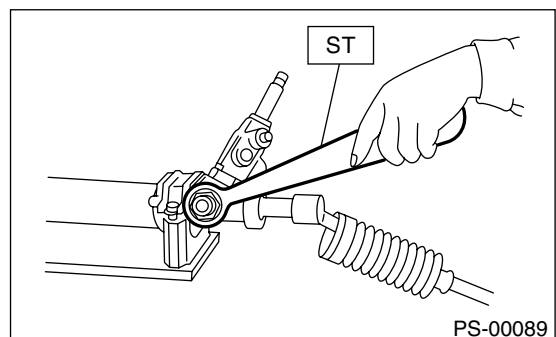

# STEERING GEARBOX

POWER ASSISTED SYSTEM (POWER STEERING)

2) Tighten adjusting screw until it no longer tightens.

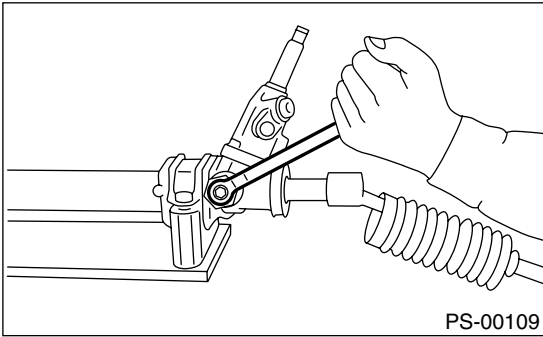

3) Remove two bolts securing valve assembly.

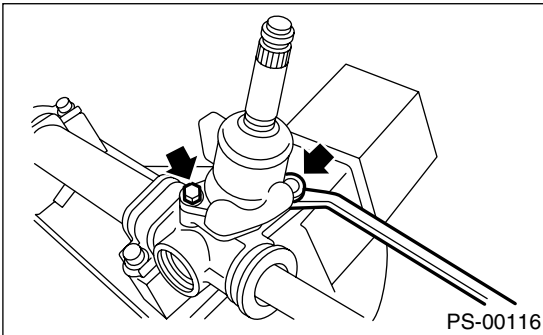

4) Carefully draw out input shaft and remove valve assembly.

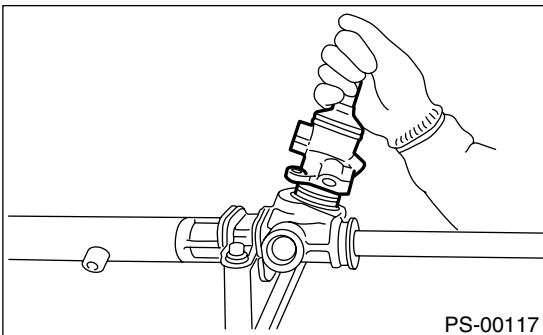

5) Draw out pinion and valve assembly from valve housing, using pipe of I.D. 44 to 46 mm (1.73 to 1.81 in) and a press.

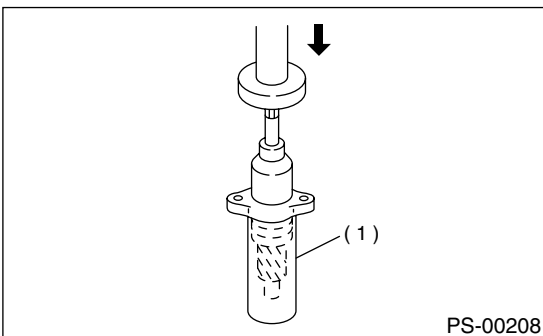

(1) Pipe

6) Pry off dust seal using screwdriver.

7) Remove snap ring using snap ring pliers.

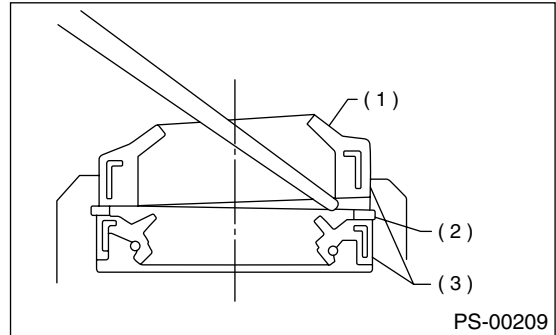

- (1) Dust seal
- (2) Snap ring
- (3) Oil seal

8) Pry off oil seal using screwdriver.

**CAUTION:**  
After removing, check inside surface of valve housing for damage. If oil seal contacting surface is damaged, replace valve housing with a new one.

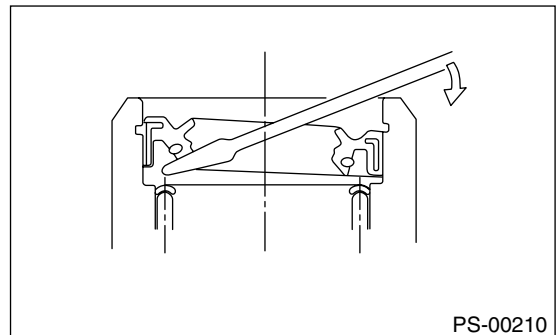

9) Remove snap ring using snap ring pliers.

**CAUTION:**

- Do not reuse removed snap ring.
- Be careful not to scratch pinion and valve assembly.

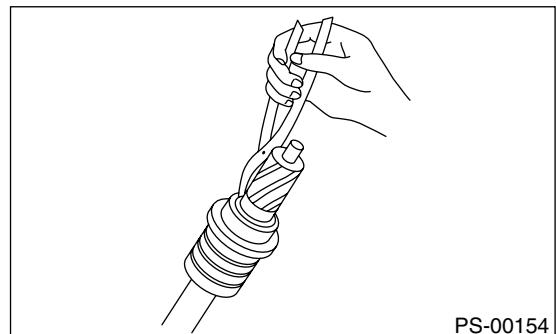

# STEERING GEARBOX

## POWER ASSISTED SYSTEM (POWER STEERING)

10) Press out bearing together with backing washer using pipe of I.D. 38.5 to 39.5 mm (1.516 to 1.555 in) and press.

**CAUTION:**

**Do not reuse removed bearing.**

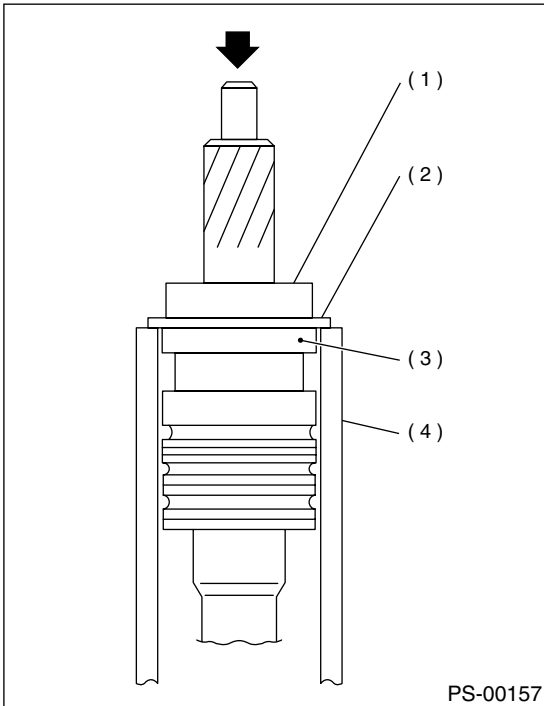

- (1) Bearing
- (2) Backing washer
- (3) Oil seal
- (4) Pipe

11) Remove oil seal.

**CAUTION:**

**Do not reuse removed oil seal.**

## D: ASSEMBLY

### 1. RACK HOUSING ASSEMBLY

**CAUTION:**

**Use only SUBARU genuine grease for gearbox.**

**Grease:**

**VALIANT GREASE M2**

**[Part No. 003608001, net 0.5 kg (1.1 lb)]**

- 1) Clean all parts and tools before reassembling.
- 2) Apply grease to teeth of rack so that grease applied is about as high as teeth, and also apply a thin film of grease to sliding portion of rack shaft.

**CAUTION:**

- When moving rack to stroke end without tie-rod attached, prevent shocks from being applied at the end.
- Do not apply grease to threaded portion at end of rack shaft.
- Move rack shaft to stroke end two (2) or three (3) times to squeeze grease which accumulates on both ends. Remove grease to prevent it from choking air passage hole.

3) Apply grease to sleeve insertion hole.

4) Apply grease to dust seal insertion hole.

**CAUTION:**

**Apply clean grease with clean hands. If material having a sharp edge is used for applying grease, oil seal at the inside might be damaged.**

5) Apply grease to sliding surface of sleeve and spring seat, then insert sleeve into pinion housing. Fit spring into sleeve screw, pack grease inside of screw, then install the screw.

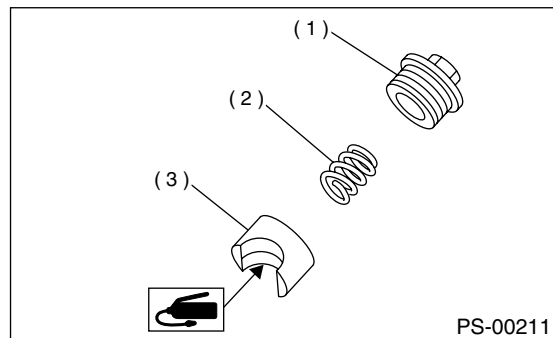

- (1) Adjusting screw
- (2) Spring
- (3) Sleeve

# STEERING GEARBOX

POWER ASSISTED SYSTEM (POWER STEERING)

6) Force-fit oil seal using ST.  
ST 34199AE060 INSTALLER

### CAUTION:

Be careful not to damage or scratch cylinder inner wall.

### NOTE:

- Apply specified power steering fluid to oil seal.
- Pay special attention not to install oil seal in wrong direction.
- Push oil seal until the stepped portion of A contacts end face of B.

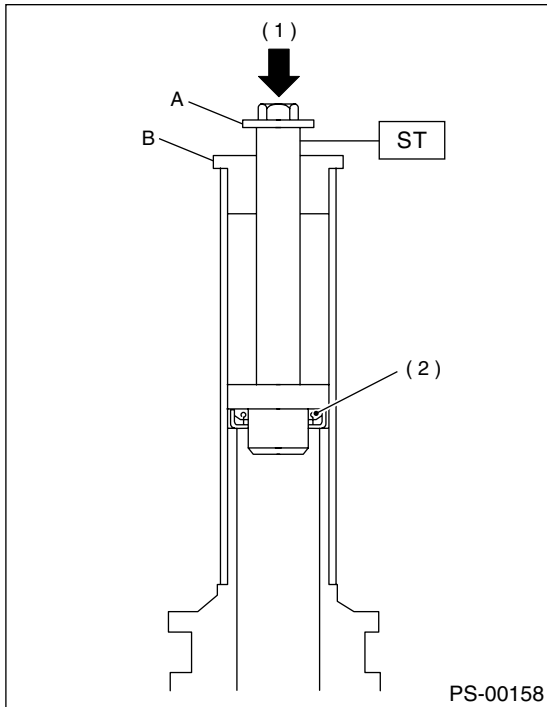

- (1) Press  
(2) Oil seal

7) Fixing rack housing  
Fix rack housing in vise using ST.  
ST 926200000 STAND

### CAUTION:

- When fixing rack housing in vise, be sure to use this special tool. Do not fix rack housing in vise using pad such as aluminum plates, etc.
- When using old rack housing, be sure to clean and remove rust before assembling. Check pinion housing bushing carefully.

8) Fit ST over toothed portion of rack assembly, and check for binding or unsmooth insertion. If any deformation is noted on flats at the end of rack, shape by using file, and wash with cleaning fluid.  
ST 926390001 COVER & REMOVER

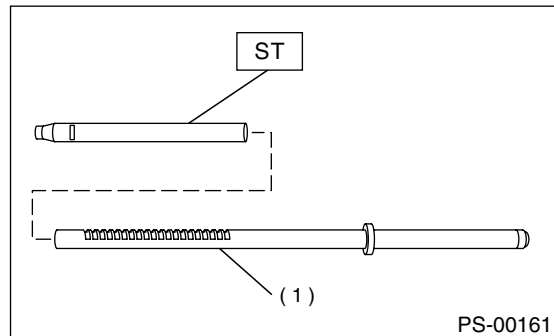

- (1) Rack ASSY

9) Apply genuine grease to teeth of thoroughly washed rack assembly, and fit ST over the toothed portion.

### CAUTION:

- Be careful not to block air passage hole with grease. Remove excessive grease.
- After fitting cover, check air passage hole for clogging. If clogged, open by removing grease from the hole.
- Check rack shaft for damage.
- Apply specified power steering fluid to this ST and surface of piston ring to prevent seal from being damaged.

10) Insert rack assembly into rack housing from cylinder side, and remove ST after it has passed completely through oil seal.

### NOTE:

Before inserting rack assembly, apply a coat of specified power steering fluid to surfaces of ST and rack piston.

ST 926390001 COVER & REMOVER

# STEERING GEARBOX

## POWER ASSISTED SYSTEM (POWER STEERING)

11) Fit ST1 and ST2 over the end of rack, and install rack bushing.

ST1 926400000 GUIDE

ST2 927660000 GUIDE

### CAUTION:

- If burrs, or nicks are found on this guide and rack shaft portion, remove by filing.
- Dip rack bushing in specified power steering fluid before installing, and pay attention not to damage O-ring and oil seal.

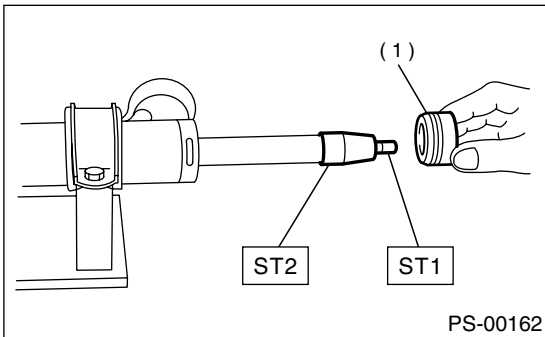

(1) Rack bushing ASSY

12) Insert rack stopper into cylinder tube until internal groove (on cylinder side) is aligned with external groove (on rack stopper). Turn rack stopper with ST so that rack stopper hole is seen through cylinder slits.

13) Insert rack stopper into rack housing, and wrap circlip using a sharp pointed pliers to secure rack stopper in position.

### CAUTION:

**Be careful not to scratch rack while winding circlip.**

### NOTE:

Rotate wrench another 90 to 180° after the end of circlip has been wrapped in.

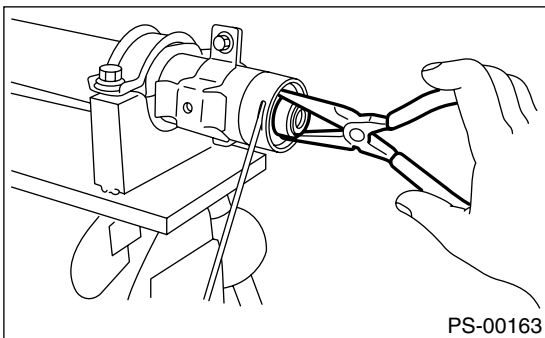

14) Fit mounting rubber onto rack housing.

15) Apply genuine grease to pinion gear and bearing of valve assembly.

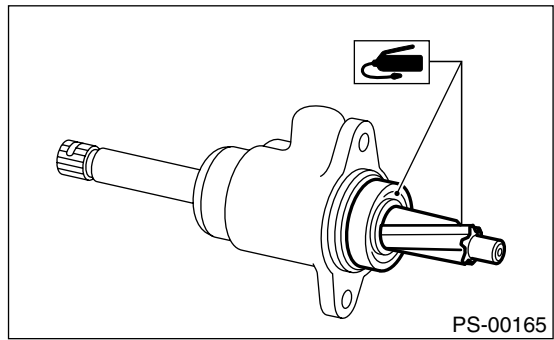

16) Install gasket on valve assembly. Insert valve assembly into place while facing rack teeth toward pinion.

### CAUTION:

**Be sure to use a new gasket.**

### NOTE:

Do not allow packing to be caught when installing valve assembly.

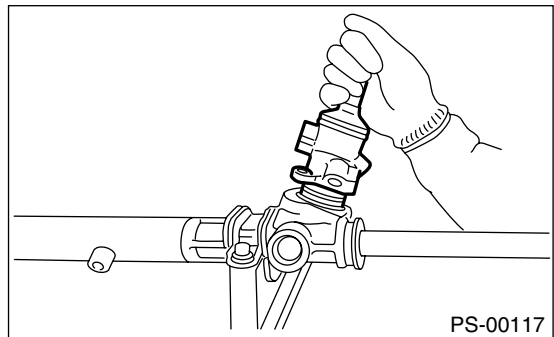

17) Tighten bolts alternately to secure valve assembly.

### Tightening torque:

**25 N·m (2.5 kgf-m, 18.1 ft-lb)**

### CAUTION:

**Be sure to alternately tighten bolts.**



# STEERING GEARBOX

POWER ASSISTED SYSTEM (POWER STEERING)

18) Install lock washers and tighten left and right tie-rods into rack ends.

**Tightening torque:**

**78 N·m (8.0 kgf-m, 58 ft-lb)**

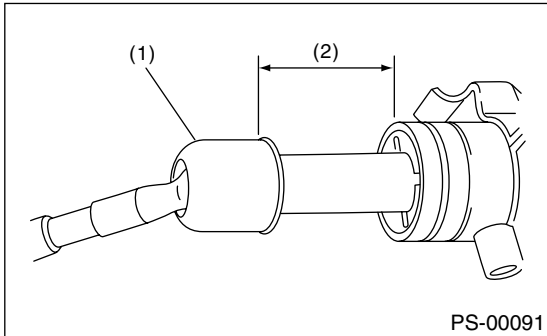

- (1) Tie-rod
- (2) Approx. 40 mm (1.57 in)

19) Bend lock washer, using chisel.

**CAUTION:**

**Be careful not to scratch rack when bending lock washer.**

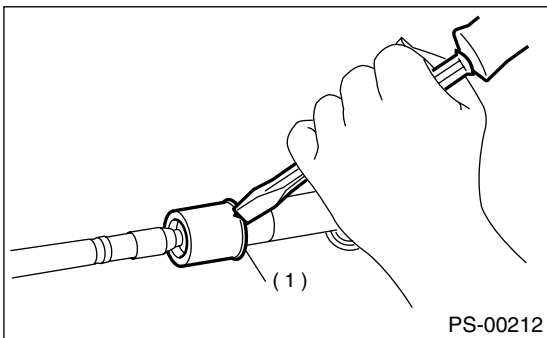

- (1) Lock washer

20) Rack and pinion backlash adjustment

- (1) Loosen adjusting screw.
- (2) Rotate input shaft so that rack is in the straight ahead direction.

(3) Apply grease to sleeve.

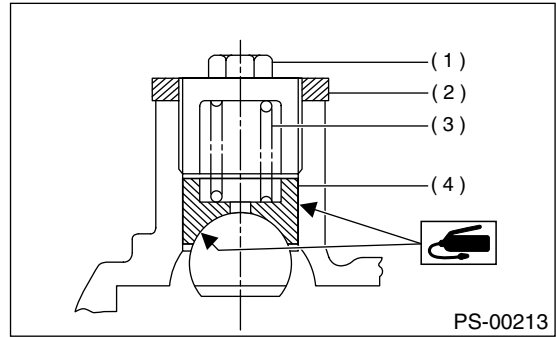

- (1) Adjusting screw
- (2) Lock nut
- (3) Spring
- (4) Sleeve

(4) Tighten adjusting screw by two threads.

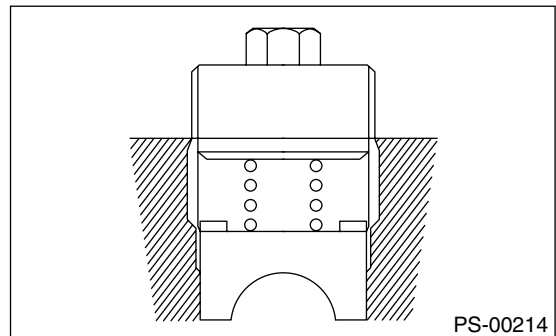

(5) Apply liquid packing to at least 1/3 of entire perimeter of adjusting screw thread.

**Liquid packing:**

**THREE BOND 1141**

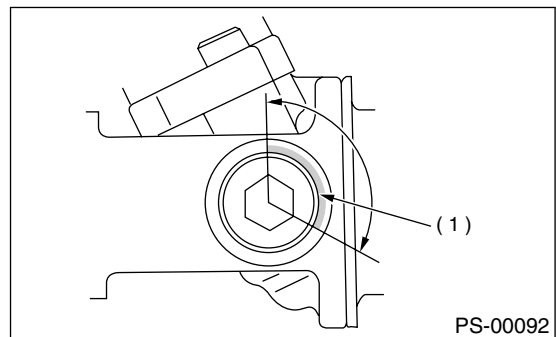

(1) Apply liquid packing to at least 1/3 of entire perimeter.

(6) Tighten adjusting screw to 7.4 N·m (0.75 kgf-m, 5.4 ft-lb) and back off 25°.

(7) Install lock nut. While holding adjusting screw with a wrench, tighten lock nut using ST.

ST 926230000 SPANNER

**Tightening torque (Lock nut):**

**39 N·m (4.0 kgf-m, 29 ft-lb)**

# STEERING GEARBOX

## POWER ASSISTED SYSTEM (POWER STEERING)

### NOTE:

- Hold adjusting screw with a wrench to prevent it from turning while tightening lock nut.
- Make adjustment so that steering wheel can be rotated fully from lock to lock without binding.

21) Inspect for service limit as per article of "Service limit". <Ref. to PS-39, SERVICE LIMIT, INSPECTION, Steering Gearbox.> Make replacement and adjustment if necessary.

22) Install boot to housing.

### NOTE:

- Before installing boot, be sure to apply grease to the groove of tie-rod.
- Install fitting portions of boots to the following portions in both sides of assembled steering gearbox.

The groove on gearbox

The groove on the rod

- Make sure that boot is installed without unusual inflation or deflation.

23) Fit clip (large) to boot, and then install boot to gearbox while holding boot flange. After installing boot, fold back boot flange to the extent that large clip cannot be seen.

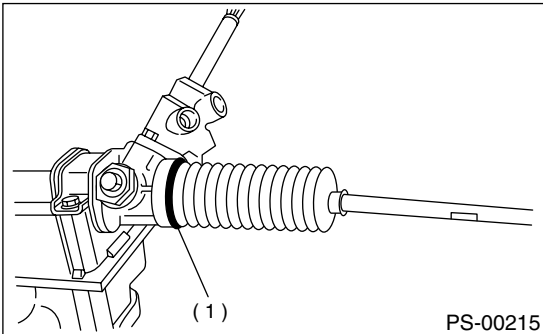

(1) Clip (large)

24) Turn boot until it seats well on gearbox and rubber mounting, then bend boot flange back.

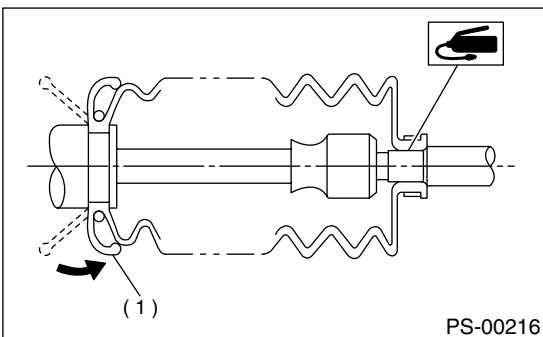

(1) Reverse after installing

25) Fix boot end with clip (small).

### CAUTION:

After installing, check boot end is positioned into groove on tie-rod.

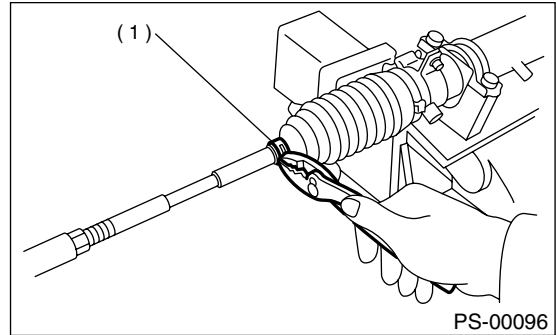

(1) Clip

26) If tie-rod end was removed, screw in lock nut and tie-rod end to screwed portion of tie-rod, and tighten lock nut temporarily in a position as shown in figure.

**Installed tie-rod length: L**  
**15 mm (0.59 in)**

### NOTE:

Pay attention to difference between right and left tie-rod ends.

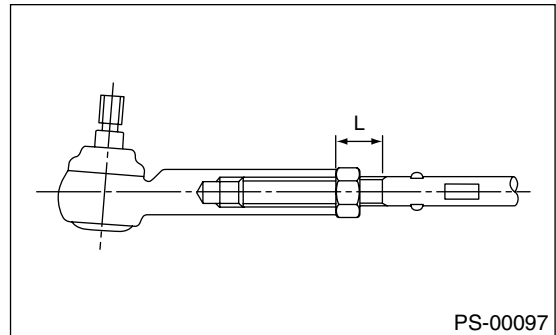

27) Inspect gearbox as follows:

"A" Holding tie-rod end, repeat lock to lock two or three times as quickly as possible.

"B" Holding tie-rod end, turn it slowly at a radius one or two times as large as possible.

After all, make sure that boot is installed in the specified position without deflation.

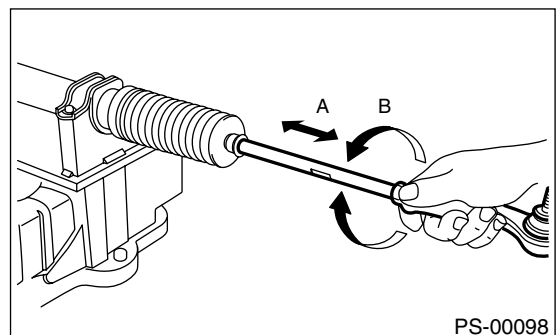

# STEERING GEARBOX

POWER ASSISTED SYSTEM (POWER STEERING)

- 28) Remove gearbox from ST.  
ST 926200000 STAND
- 29) Install four pipes on gearbox.  
(1) Connect pipes A and B to four pipe joints of gearbox. Connect upper pipe B first, and lower pipe A.

### Tightening torque:

**13 N·m (1.3 kgf-m, 9.4 ft-lb)**

- (2) Connect pipes C and D to gearbox.  
Connect lower pipe C first, and upper pipe D second.

### Tightening torque:

**15 N·m (1.5 kgf-m, 10.8 ft-lb)**

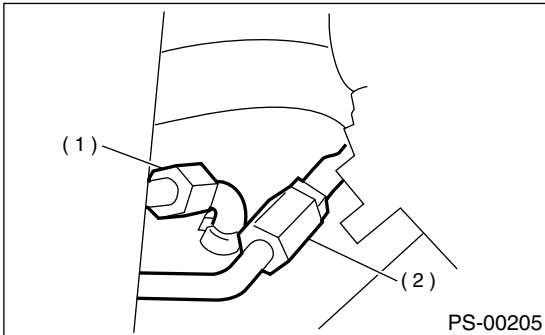

- (1) Pipe C  
(2) Pipe D

## 2. CONTROL VALVE ASSEMBLY

### Specified steering grease:

**VALIANT GREASE M2 (Part No. 003608001)**

- 1) Clean all parts and tools before reassembling.  
2) Press-fit oil seal into valve housing using ST and press.

ST 927610000 INSTALLER

### NOTE:

Before fitting, coat oil seal fully with ATF DEXRON ATF DEXRON III or equivalent.

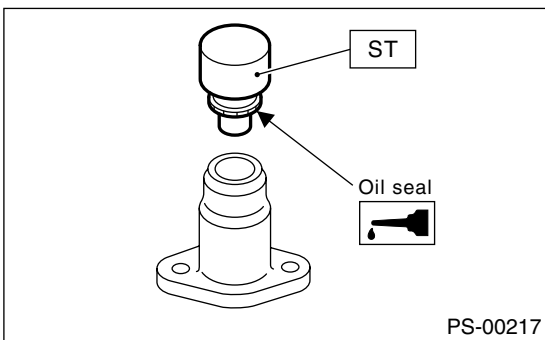

- 3) Fit snap ring in snap ring groove using snap ring pliers.

### CAUTION:

**Be careful not to scratch oil seal with snap ring pliers.**

### NOTE:

Rotate snap ring to check for proper installation.

- 4) Put vinyl tape around pinion shaft splines to protect oil seal from damage.  
5) Fit pinion and valve assembly into valve housing.

### NOTE:

Apply specified power steering fluid to outer diameter surface of input shaft and outer surface of valve body seal ring, and pay special attention not to damage seal when inserting pinion and valve assembly.

- 6) Secure valve assembly to ST1 and ST2.  
7) Put ST3 over pinion, and insert oil seal, then force-fit oil seal into housing using ST4.

ST1 926370000 INSTALLER A  
ST2 927630000 STAND BASE  
ST3 926360000 INSTALLER A  
ST4 927620000 INSTALLER B

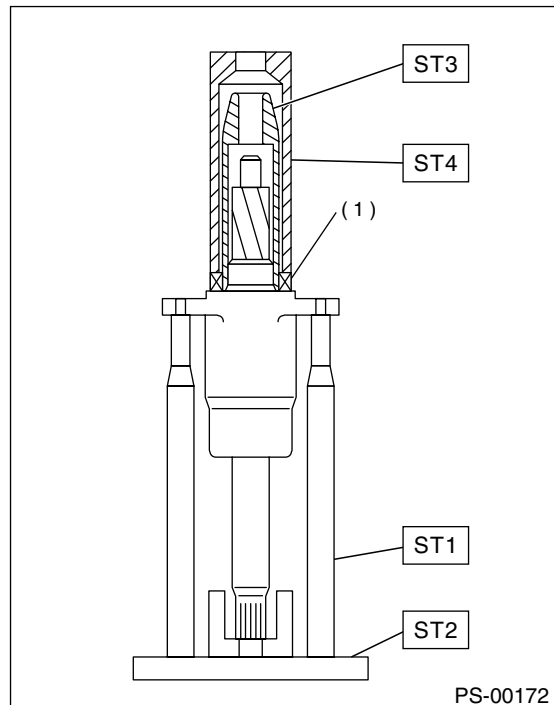

- (1) Oil seal

### NOTE:

- Apply specified power steering fluid to oil seal and ST3, being careful not to damage oil seal lip.
- Push oil seal until ST3 contacts housing end face.

- 8) Remove ST3, and fit backing washer.

# STEERING GEARBOX

## POWER ASSISTED SYSTEM (POWER STEERING)

- 9) Force-fit ball bearing using ST3.  
ST1 926370000 INSTALLER A  
ST2 34099FA100 STAND BASE  
ST3 927640000 INSTALLER B

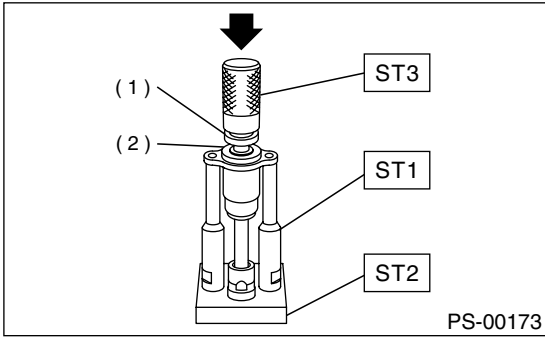

- (1) Ball bearing  
(2) Backing washer

### NOTE:

Be careful not to tilt ball bearing during installation.

- 10) Apply genuine grease to pinion gear and bearing of valve assembly.

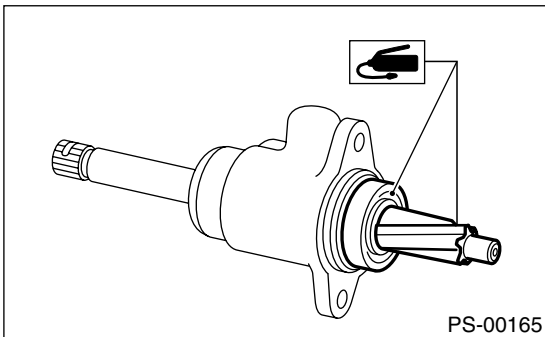

- 11) Install gasket on valve assembly. Insert valve assembly into place while facing rack teeth toward pinion.

### CAUTION:

**Be sure to use a new gasket.**

### NOTE:

Do not allow packing to be caught when installing valve assembly.

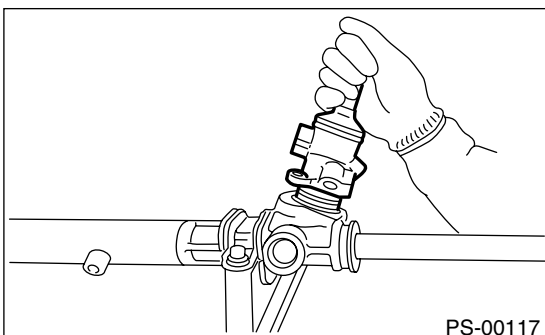

- 12) Tighten bolts alternately to secure valve assembly.

### Tightening torque:

**25 N·m (2.5 kgf·m, 18.1 ft·lb)**

### CAUTION:

**Be sure to alternately tighten bolts.**

- 13) Apply grease to sleeve insertion hole.

- 14) Apply grease to dust seal insertion hole.

### CAUTION:

**Apply clean grease with clean hands. If material having a sharp edge is used for applying grease, oil seal at the inside might be damaged.**

- 15) Press-fit dust seal into gearbox housing while tapping it via a spanner or the like so that stepping between gearbox and dust seal is normally 2 mm (0.08 in).

### Depth: A

**2 mm (0.08 in)**

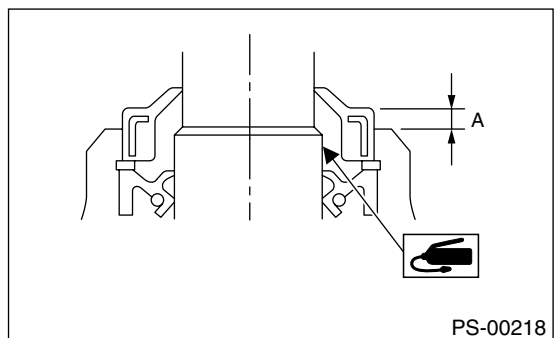
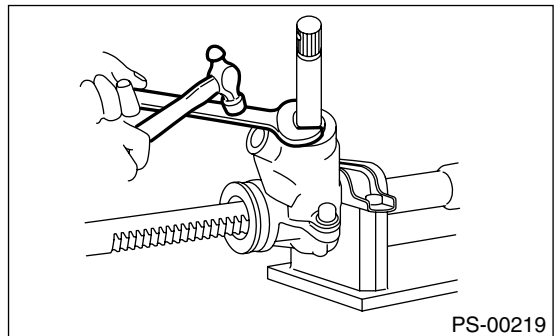

# STEERING GEARBOX

## POWER ASSISTED SYSTEM (POWER STEERING)

16) Apply grease to sliding surface of sleeve and spring seat, then insert sleeve into pinion housing. Fit spring into sleeve screw, pack grease inside of screw, then install the screw.

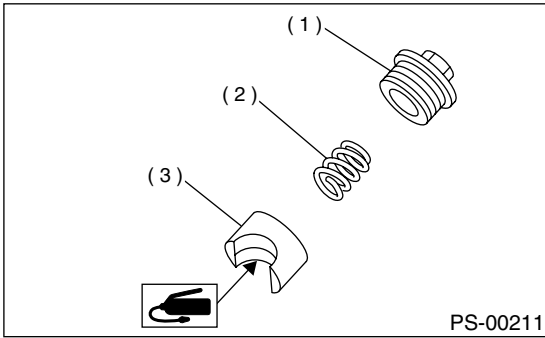

- (1) Adjusting screw
- (2) Spring
- (3) Sleeve

17) Rack and pinion backlash adjustment

- (1) Loosen adjusting screw.
- (2) Rotate input shaft so that rack is in the straight ahead direction.
- (3) Apply grease to sleeve.

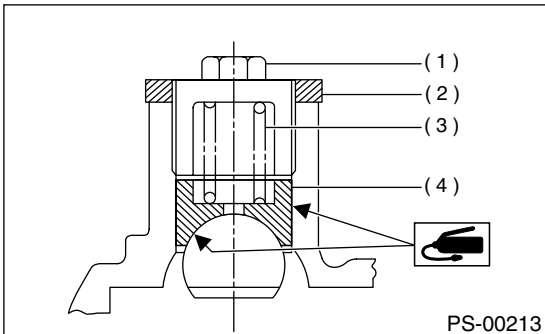

- (1) Adjusting screw
- (2) Lock nut
- (3) Spring
- (4) Sleeve

(4) Tighten adjusting screw by two threads.

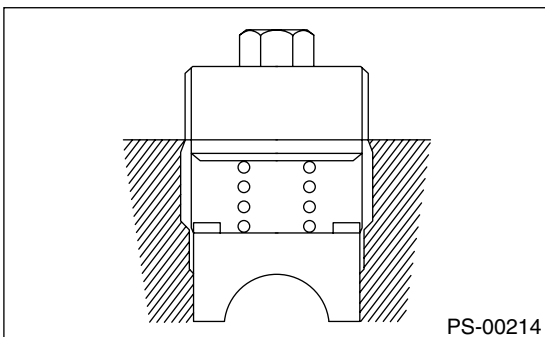

(5) Apply liquid packing to at least 1/3 of entire perimeter of adjusting screw thread.

**Liquid packing:**  
**THREE BOND 1141**

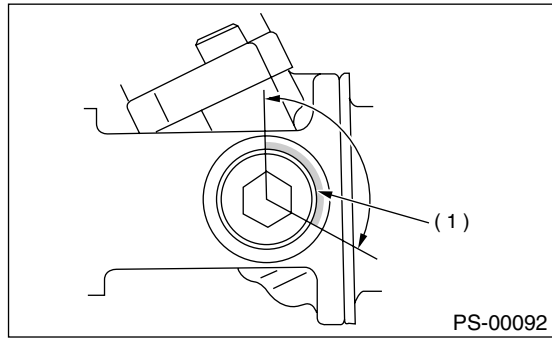

- (1) Apply liquid packing to at least 1/3 of entire perimeter.

(6) Tighten adjusting screw to 7.4 N·m (0.75 kgf-m, 5.4 ft-lb) and back off 25°.

(7) Install lock nut. While holding adjusting screw with a wrench, tighten lock nut using ST.

ST 926230000 SPANNER

**Tightening torque (Lock nut):**  
**39 N·m (4.0 kgf-m, 29 ft-lb)**

NOTE:

- Hold adjusting screw with a wrench to prevent it from turning while tightening lock nut.
- Make adjustment so that steering wheel can be rotated fully from lock to lock without binding.

18) Check for service limit as per article of "Service limit". <Ref. to PS-39, SERVICE LIMIT, INSPECTION, Steering Gearbox.> Make replacement and adjustment if necessary.

# STEERING GEARBOX

## POWER ASSISTED SYSTEM (POWER STEERING)

### E: INSPECTION

#### 1. BASIC INSPECTION

1) Clean all disassembled parts, and check for wear, damage, or any other faults, then repair or replace as necessary.

2) When disassembling, check inside of gearbox for water. If any water is found, carefully check boot for damage, input shaft dust seal, adjusting screw and boot clips for poor sealing. If faulty, replace with new parts.

No.	Parts	Inspection	Corrective action
1	Input shaft	(1) Bend of input shaft (2) Damage on serration	If bend or damage is excessive, replace entire gearbox.
2	Dust seal	(1) Crack or damage (2) Wear	If outer wall slips, lip is worn out or damage is found, replace it with new one.
3	Rack and pinion	Poor mating of rack with pinion	(1) Adjust backlash properly. By measuring turning torque of gearbox and sliding resistance of rack, check if rack and pinion engage uniformly and smoothly with each other. (Refer to "Service limit".) (2) Keeping rack pulled out all the way so that all teeth emerge, check teeth for damage. Even if abnormality is found in either (1) or (2), replace entire gearbox.
4	Gearbox unit	(1) Bend of rack shaft (2) Bend of cylinder portion (3) Crack or damage on cast iron portion	Replace gearbox with new one.
		(4) Wear or damage on rack bush	If free play of rack shaft in radial direction is out of the specified range, replace gearbox with new one. (Refer to "Service limit".)
		(5) Wear on input shaft bearing	If free plays of input shaft in radial and axial directions are out of the specified ranges, replace gearbox with new one. (Refer to "Service limit".)
5	Boot	Crack, damage or deterioration	Replace.
6	Tie-rod	(1) Looseness of ball joint (2) Bend of tie-rod	Replace.
7	Tie-rod end	Damage or deterioration on dust seal	Replace.
8	Adjusting screw spring	Deterioration	Replace.
9	Boot clip	Deterioration	Replace.
10	Sleeve	Damage	Replace.
11	Pipes	(1) Damage to flared surface (2) Damage to flare nut (3) Damage to pipe	Replace.

# STEERING GEARBOX

POWER ASSISTED SYSTEM (POWER STEERING)

## 2. SERVICE LIMIT

Make a measurement as follows. If it exceeds the specified service limit, adjust or replace.

### NOTE:

When making a measurement, vise gearbox by using ST. Never vise gearbox by inserting aluminum plates, etc. between vise and gearbox.

ST 926200000 STAND

### Sliding resistance of rack shaft:

#### Service limit

**304 N (31 kgf, 68 lb) or less**

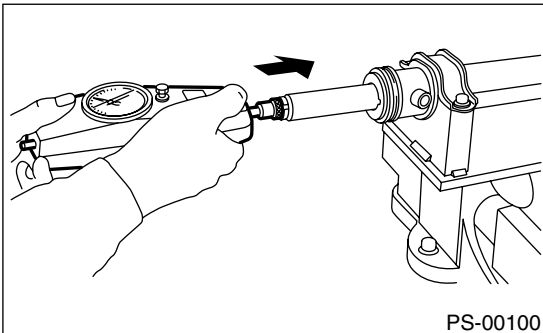
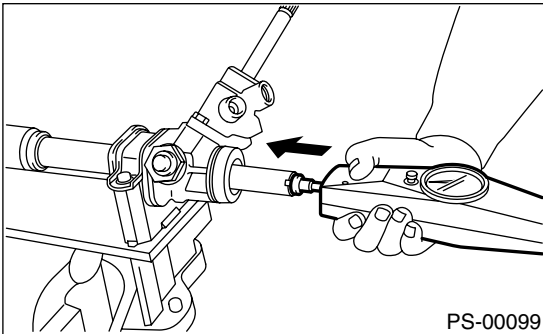

## 3. RACK SHAFT PLAY IN RADIAL DIRECTION

### Right-turn steering:

#### Service limit

**0.19 mm (0.0075 in) or less**

#### On condition

**L: 5 mm (0.20 in)**

**P: 122.6 N (12.5 kgf, 27.6 lb)**

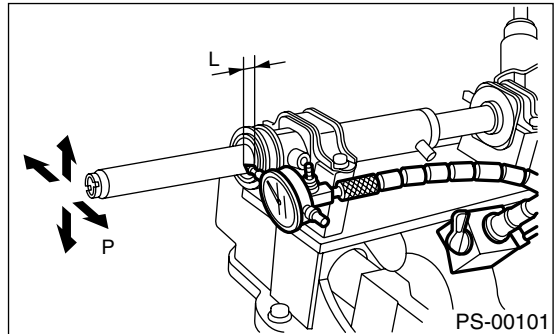

### Left-turn steering:

#### Service limit

**Direction**  $\longleftrightarrow$

**0.3 mm (0.012 in) or less**

**Direction**  $\longleftrightarrow$

**0.15 mm (0.0059 in) or less**

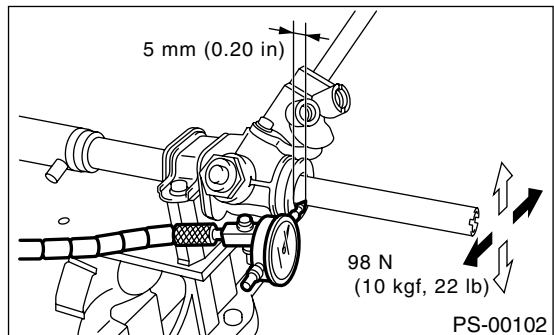

# STEERING GEARBOX

POWER ASSISTED SYSTEM (POWER STEERING)

## 4. INPUT SHAFT PLAY

*In radial direction:*

**Service limit**

**0.18 mm (0.0071 in) or less**

*On condition*

**P: 98 N (10 kgf, 22 lb)**

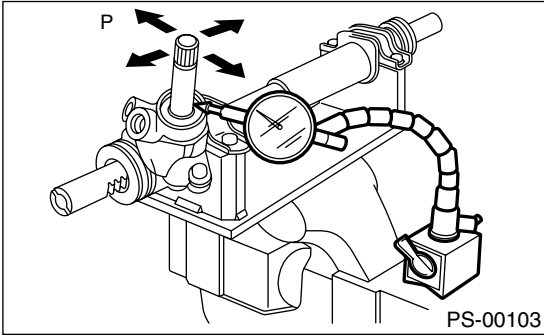

*In axial direction:*

**Service limit**

**0.5 mm (0.020 in) or less**

*On condition*

**P: 20 — 49 N (2 — 5 kgf, 4 — 11 lb)**

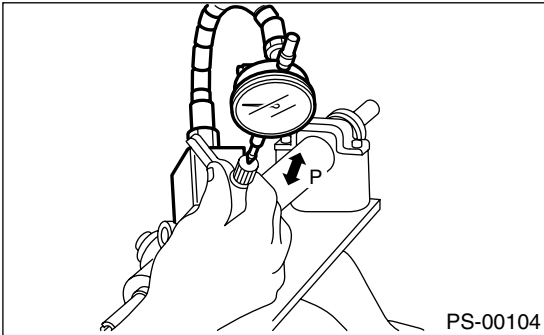

## 5. TURNING RESISTANCE OF GEARBOX

Using ST, measure gearbox turning resistance.

ST 926230000 SPANNER

**Service limit:**

**Straight-ahead position within 30 mm (1.18 in) from rack center**

**Less than 11.18 N (1.14 kgf, 2.51 lb)**

**Maximum allowable resistance**

**12.7 N (1.3 kgf, 2.9 lb)**

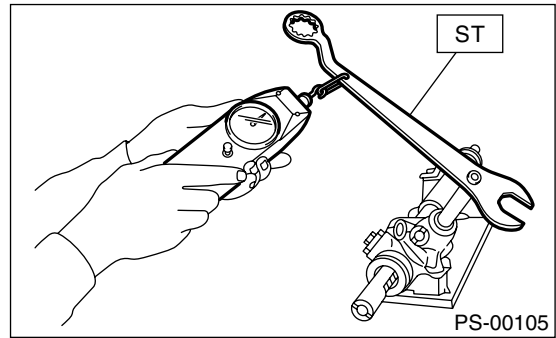



# STEERING GEARBOX

POWER ASSISTED SYSTEM (POWER STEERING)

## 6. OIL LEAKING

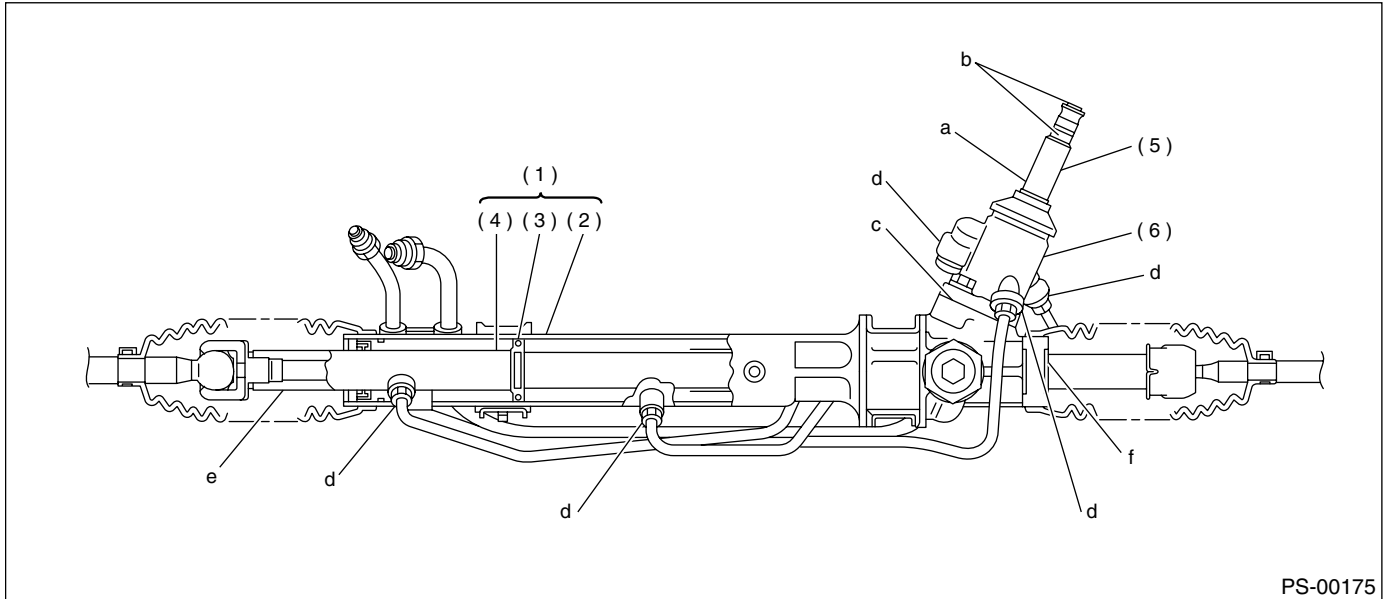

- (1) Power cylinder
- (2) Cylinder

- (3) Rack piston
- (4) Rack axle

- (5) Input shaft
- (6) Valve housing

### • Oil leaking points

1) If leak point is other than a, b, c, or d, perform the 5th step in "Oil leak check procedure and replacement parts" before dismantling gearbox from vehicle. <Ref. to "Oil leak check procedure and replacement parts".> If gearbox is dismantled without confirming where the leak is, it must be mounted again to locate the leak point.

2) Even if the location of the leak can be easily found by observing the leaking condition, it is necessary to thoroughly remove the oil from the suspected portion and turn the steering wheel from lock to lock about 30 to 40 times with engine running, then make comparison of the suspected portion between immediately after and several hours after this operation.

3) Before starting oil leak repair work, be sure to clean the gearbox, hoses, pipes, and surrounding parts. After completing repair work, clean these areas again.

### • Oil leak check procedure and replacement parts

#### NOTE:

Parts requiring replacement are described in the smallest unit of spare parts including damaged parts and spare parts damaged. In actual disassembly work, accidental damage as well as inevitable damage to some related parts must be taken into account, and spare parts for them must also be prepared. However, it is essential to pinpoint the cause of trouble, and limit the number of replacement parts as much as possible.

#### 1) Leakage from "a"

The oil seal is damaged. Replace valve assembly with a new one.

#### 2) Leakage from "b"

The torsion bar O-ring is damaged. Replace valve assembly with a new one.

#### 3) Leakage from "c"

The oil seal is damaged. Replace valve assembly or oil seal with a new one.

#### 4) Leakage from "d"

The pipe is damaged. Replace the faulty pipe or O-ring.

5) If leak is other than a, b, c, or d, and if oil is leaking from the gearbox, move the right and left boots toward tie-rod end side, respectively, with the gearbox mounted to the vehicle, and remove oil from the surrounding portions. Then, turn the steering wheel from lock to lock 30 to 40 times with the engine running, then make comparison of the leaked portion immediately after and several hours after this operation.

#### (1) Leakage from "e"

The cylinder seal is damaged. Replace rack bush with a new one.

#### (2) Leakage from "f"

There are two possible causes. Take following step first. Remove the pipe assembly B from the valve housing, and close the circuit with ST.

#### ST 926420000 PLUG

Turn the steering wheel from lock to lock 30 to 40 times with the engine running, then make comparison of the leaked portion between im-

# STEERING GEARBOX

## POWER ASSISTED SYSTEM (POWER STEERING)

mediately after and several hours after this operation.

### CAUTION:

- If leakage from “f” is noted again:  
The oil seal of pinion and valve assembly is damaged. Replace pinion and valve assembly with a new one. Or replace the oil seal and the parts that are damaged during disassembly with new ones.
- If oil stops leaking from “f”:  
The oil seal of rack housing is damaged. Replace the oil seal and the parts that are damaged during disassembly with new ones.

## F: ADJUSTMENT

1) Adjust front toe.

**Standard of front toe:**

**IN 3 — OUT 3 mm (IN 0.12 — OUT 0.12 in)**

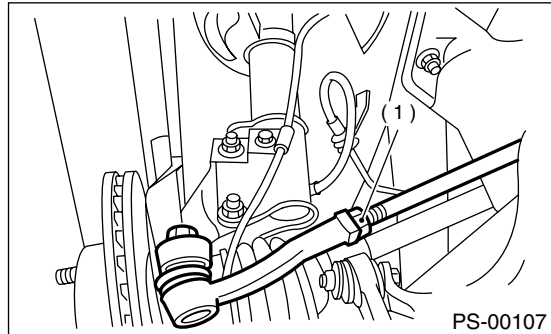

(1) Lock nut

2) Adjust steering angle of wheels.

**Standard of steering angle:**

Model	Except <b>OUTBACK, Pick-up</b>	<b>OUTBACK, Pick-up</b>
Inner wheel	$36.3^{\circ} \pm 1.5^{\circ}$	$34.5^{\circ} \pm 1.5^{\circ}$
Outer wheel	$31.6^{\circ} \pm 1.5^{\circ}$	$30.3^{\circ} \pm 1.5^{\circ}$

3) If steering wheel spokes are not horizontal when wheels are set in the straight ahead position, and error is more than  $5^{\circ}$  on the periphery of steering wheel, correctly re-install the steering wheel.

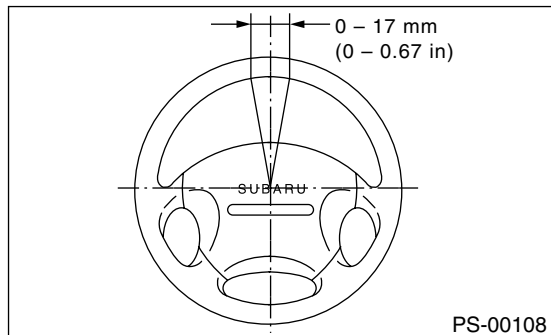

4) If steering wheel spokes are not horizontal with vehicle set in the straight ahead position after this adjustment, correct it by turning the right and left tie-rods in the same direction by the same turns.

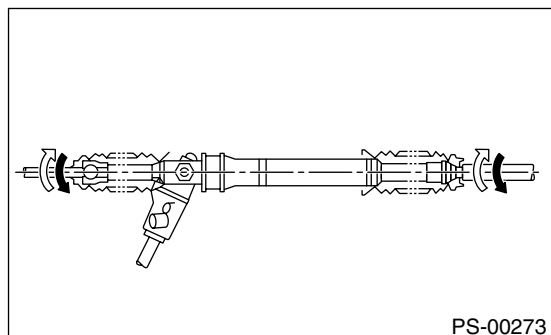

# PIPE ASSEMBLY

## POWER ASSISTED SYSTEM (POWER STEERING)

### 6. Pipe Assembly

#### A: REMOVAL

- 1) Set the vehicle on the lift.
- 2) Disconnect battery ground cable.
- 3) Lift vehicle and remove jack-up plate.

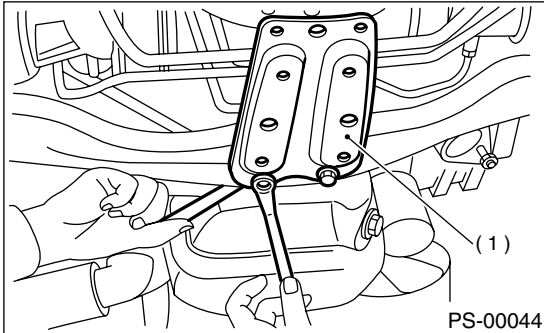

(1) Jack-up plate

- 4) Remove one pipe joint at the center of gearbox, and connect vinyl hose to pipe and joint. Discharge fluid by turning steering wheel fully clockwise and counterclockwise. Discharge fluid similarly from the other pipe.

#### CAUTION:

**Improper removal and installation of parts often causes fluid leak trouble. To prevent this, clean the surrounding portions before disassembly and reassembly, and pay special attention to keep dirt and other foreign matter from mating surfaces.**

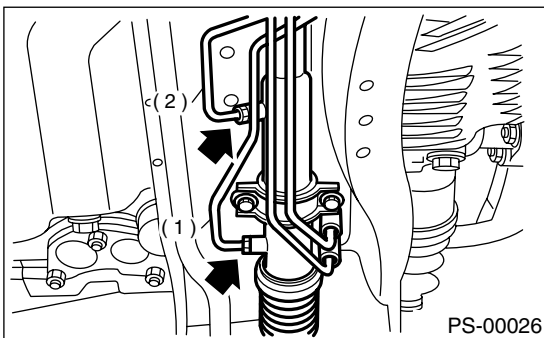

(1) Pipe A  
(2) Pipe B

- 5) Remove clamp E from pipes.

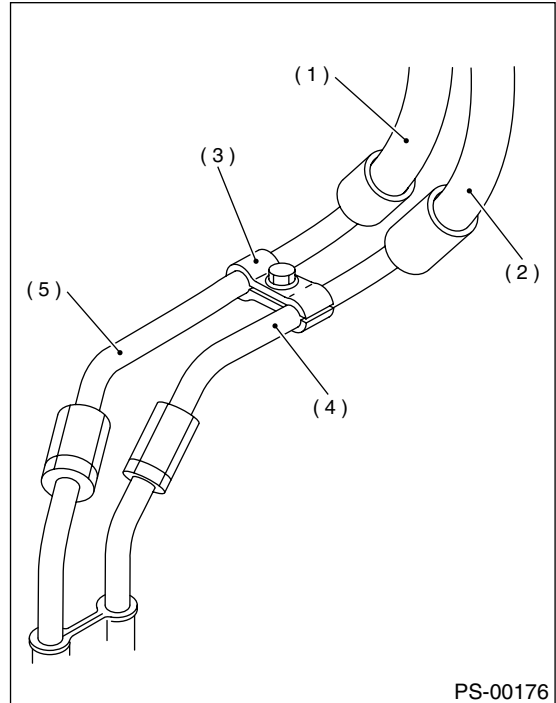

(1) Return hose  
(2) Pressure hose  
(3) Clamp E  
(4) Pipe C  
(5) Pipe D

- 6) Disconnect pipe C-D.  
Disconnect pipe C-D from pipe (on the gearbox side).

#### CAUTION:

- When disconnecting pipe C-D, use two wrenches to prevent deformities.
- Be careful to keep pipe connections free from foreign matter.

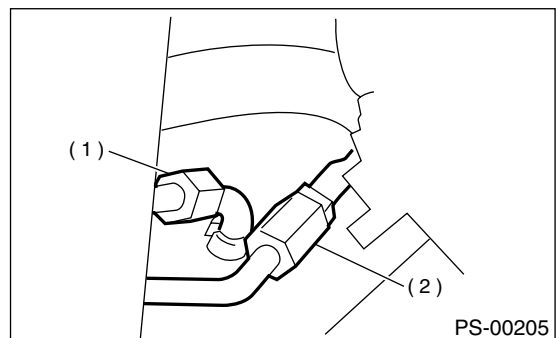

(1) Pipe C  
(2) Pipe D

# PIPE ASSEMBLY

## POWER ASSISTED SYSTEM (POWER STEERING)

### 2.5 L model

Disconnect pipe C from oil pump. Disconnect pipe D from return hose.

#### CAUTION:

- Do not allow fluid from the hose end to come into contact with pulley belt.
- To prevent foreign matter from entering the hose and pipe, cover the open ends of them with a clean cloth.

Non-TURBO model

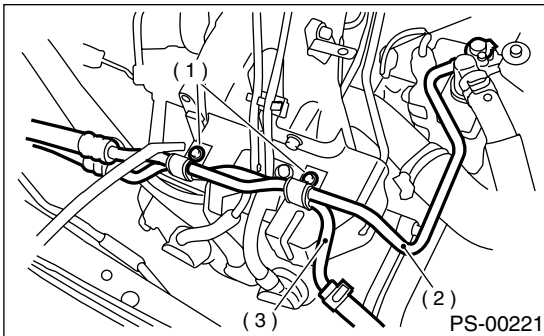

TURBO model

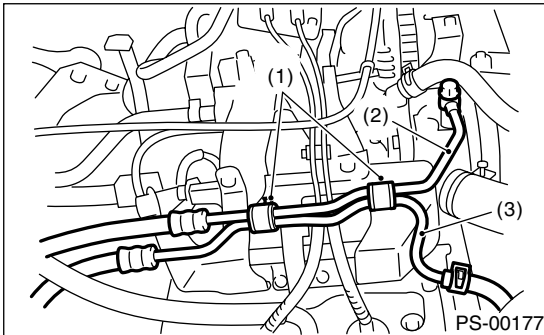

- (1) Bolt A
- (2) Pipe C
- (3) Pipe D

### 3.0 L model

Disconnect pressure hose from oil pump. Disconnect return hose from reservoir tank.

#### CAUTION:

- Do not allow fluid from the hose end to come into contact with pulley belt.
- To prevent foreign matter from entering the hose and pipe, cover the open ends of them with a clean cloth.

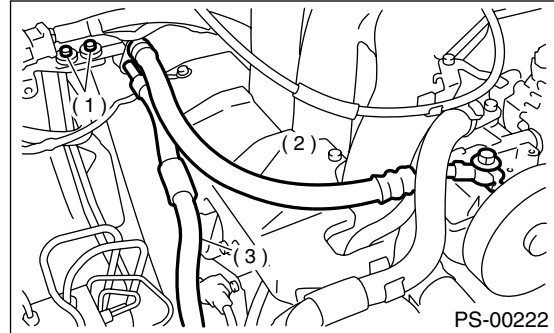

- (1) Bolt A
- (2) Pressure hose
- (3) Return hose

# PIPE ASSEMBLY

POWER ASSISTED SYSTEM (POWER STEERING)

## B: INSTALLATION

1) Tighten bolt A.

### CAUTION:

Visually check that hose between tank and pipe D is free from bending or twisting.

### 2.5 L model

Non-TURBO model

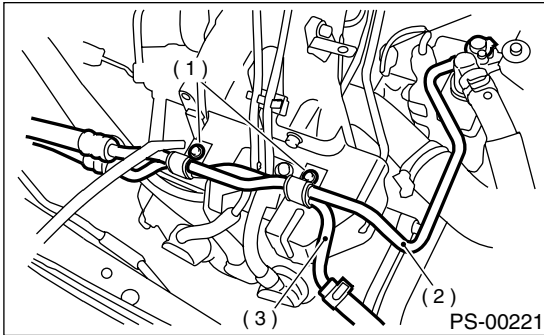

TURBO model

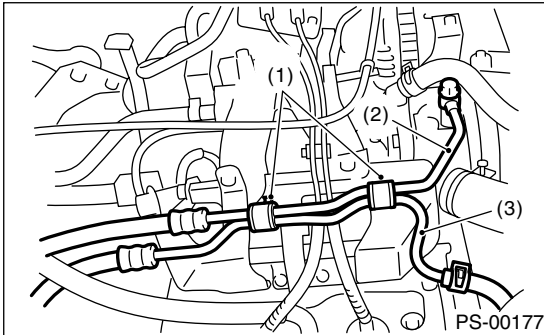

- (1) Bolt A
- (2) Pipe C
- (3) Pipe D

### 3.0 L model

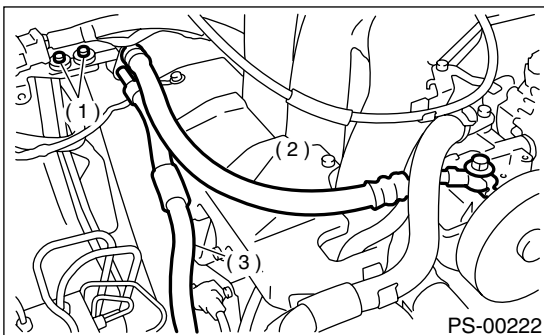

- (1) Bolt A
- (2) Pressure hose
- (3) Return hose

- (1) Connect pipe D or return hose to oil tank.
- (2) Connect pipe C or pressure hose to oil pump.

### CAUTION:

Use anew gasket.

### Tightening torque:

**39 N·m (4.0 kgf-m, 28.9 ft-lb)**

(3) Tighten bolt A.

### Tightening torque:

**13 N·m (1.3 kgf-m, 9.4 ft-lb)**

2) Temporarily connect pipes C and D.

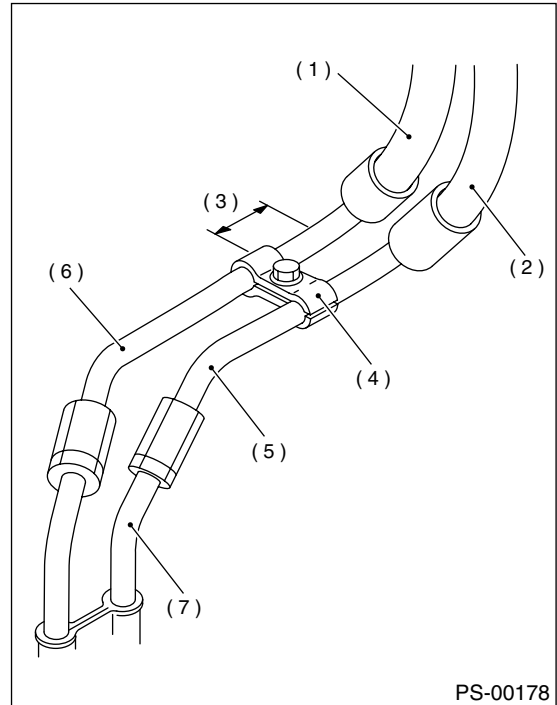

- (1) Return hose
- (2) Pressure hose
- (3) Approx. 30 mm (1.18 in)
- (4) Clamp E
- (5) Pipe C
- (6) Pipe
- (7) Pipe (on gearbox side)

# PIPE ASSEMBLY

## POWER ASSISTED SYSTEM (POWER STEERING)

3) Temporarily install clamp E on pipes C and D, and tighten clamp E firmly.

### CAUTION:

Ensure that the letter “8” on each clamp are diagonally opposite each other as shown in figure.

### Tightening torque:

**7.4 N·m (0.75 kgf-m, 5.4 ft-lb)**

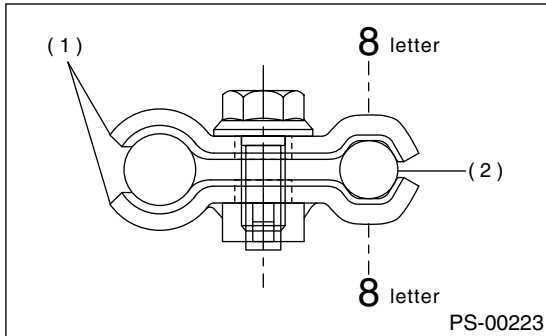

- (1) Clamp E
- (2) Pipe C

4) Tighten joint nut.

### Tightening torque:

**15 N·m (1.5 kgf-m, 10.8 ft-lb)**

5) Connect pipe A and B.

Connect pipes A and B to four pipe joints of gear-box. Connect upper pipe B first, and lower pipe A second.

### Tightening torque:

**13 N·m (1.3 kgf-m, 9.4 ft-lb)**

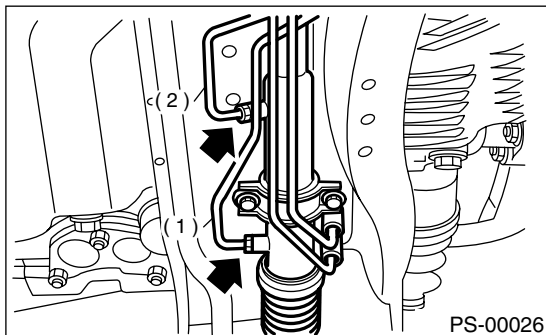

- (1) Pipe A
- (2) Pipe B

6) Install jack-up plate.

7) Connect battery ground cable.

8) Feed the specified fluid.

### NOTE:

Never start the engine before feeding the fluid; otherwise vane pump might be seized up.

# PIPE ASSEMBLY

POWER ASSISTED SYSTEM (POWER STEERING)

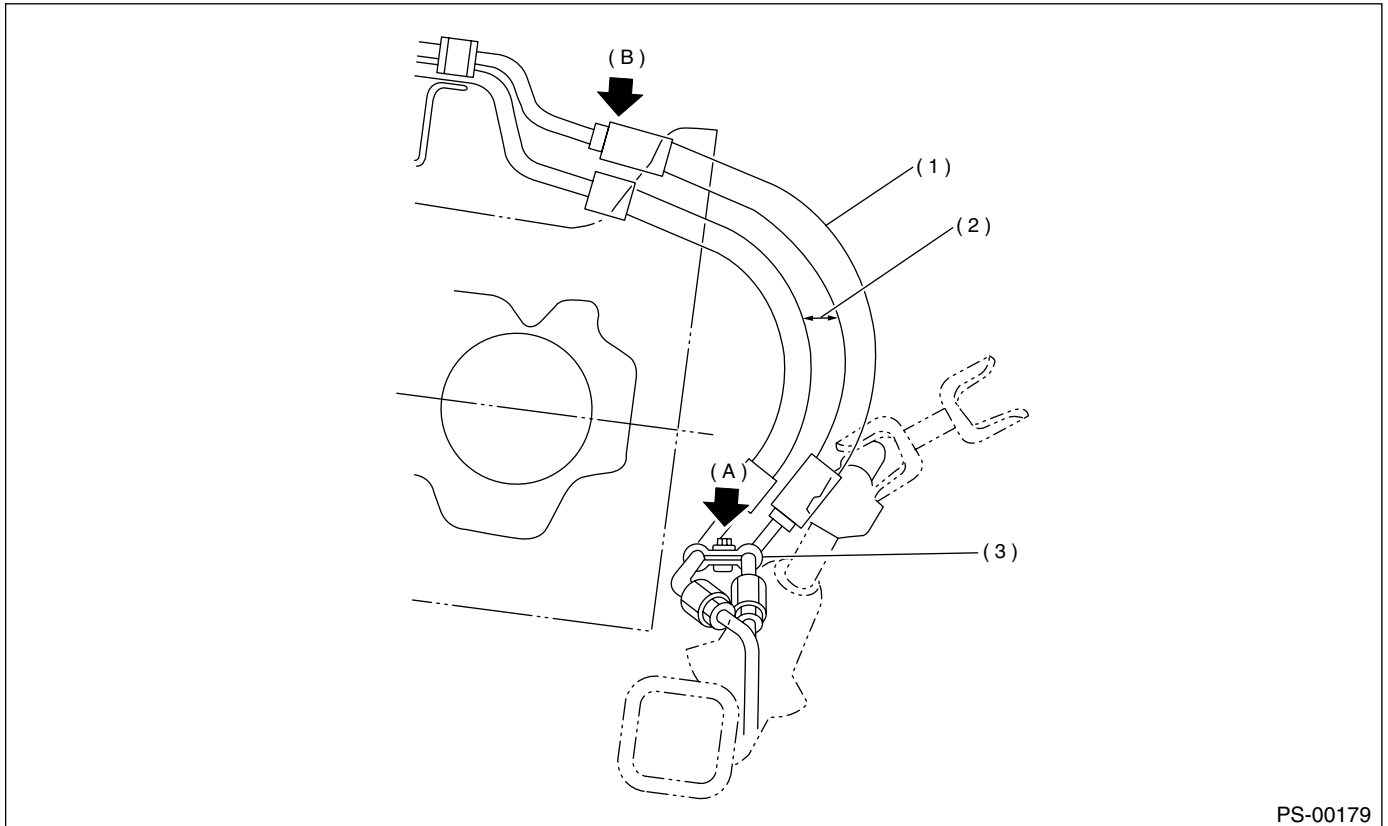

PS-00179

(1) High-pressure hose

(2) No interference is allowed between hoses.

(3) Clearance between crossmember and pipe: 3 - 8 mm (0.12 - 0.31 in)

9) Finally check clearance between pipes and/or hoses, as shown above.

If clearance between cruise control pump and power steering hose is less than 10 mm (0.39 in), proceed as follows:

(1) Move clamped section (A) (refer to figure above.) down to a point where pipe is close to crossmember.

**Pipe-to-crossmember clearance:**

**10 mm (0.39 in), min.**

(2) Check that clearance between cruise control pump and power steering hose is at least 10 mm (0.39 in). If it is not, bend section (B) down until a clearance of at least 10 mm (0.39 in) is obtained.

# PIPE ASSEMBLY

## POWER ASSISTED SYSTEM (POWER STEERING)

### C: INSPECTION

Check all disassembled parts for wear, damage or other abnormalities. Repair or replace faulty parts as required.

Part name	Inspection	Remedy
Pipe	<ul style="list-style-type: none"> <li>• O-ring fitting surface for damage</li> <li>• Nut for damage</li> <li>• Pipe for damage</li> </ul>	Replace with new one.
Clamp	<ul style="list-style-type: none"> <li>• Clamps for weak clamping force</li> </ul>	Replace with new one.
Hose	<ul style="list-style-type: none"> <li>• Flared surface for damage</li> <li>• Flare nut for damage</li> <li>• Outer surface for cracks</li> <li>• Outer surface for wear</li> <li>• Clip for damage</li> <li>• End coupling or adapter for degradation</li> </ul>	Replace with new one.

#### CAUTION:

**Although surface layer materials of rubber hoses have excellent weathering resistance, heat resistance and resistance for low temperature brittleness, they are likely to be damaged chemically by brake fluid, battery electrolyte, engine oil and automatic transmission fluid and their service lives are to be very shortened. It is very important to keep the hoses free from before mentioned fluids and to wipe out immediately when the hoses are adhered with the fluids.**

**Since resistances for heat or low temperature brittleness are gradually declining according to time accumulation of hot or cold conditions for the hoses and their service lives are shortening accordingly, it is necessary to perform careful inspection frequently when the vehicle is used in hot weather areas, cold weather area and/or a driving condition in which many steering operations are required in short time.**

**Particularly continuous work of relief valve over 5 seconds causes to reduce service lives of the hoses, the oil pump, the fluid, etc. due to over heat.**

**So, avoid to keep this kind of condition when servicing as well as driving.**

Trouble	Possible cause	Corrective action
Pressure hose burst	Excessive holding time of relief status	Instruct customers.
	Malfunction of relief valve	Replace oil pump.
	Poor cold characteristic of fluid	Replace fluid.
Forced out return hose	Poor connection	Correct.
	Poor holding of clip	Retighten.
	Poor cold characteristic of fluid	Replace fluid.
Fluid bleeding out of hose slightly	Wrong layout, tensioned	Replace hose.
	Excessive play of engine due to deterioration of engine mounting rubber	Replace defective parts.
	Improper stop position of pitching stopper	Replace defective parts.
Crack on hose	Excessive holding time of relief status	Replace. Instruct customer.
	Excessive tightening torque for return hose clip	Replace.
	Power steering fluid, brake fluid, engine oil, electrolyte adhere on the hose surface	Replace. Pay attention on service work.
	Too many times use in extremely cold weather	Replace. Instruct customers.



# PIPE ASSEMBLY

POWER ASSISTED SYSTEM (POWER STEERING)

## CAUTION:

It is likely that although one judges fluid leakage, there is actually no leakage. This is because the fluid spilt during the last maintenance was not completely wiped off. Be sure to wipe off spilt fluid thoroughly after maintenance.

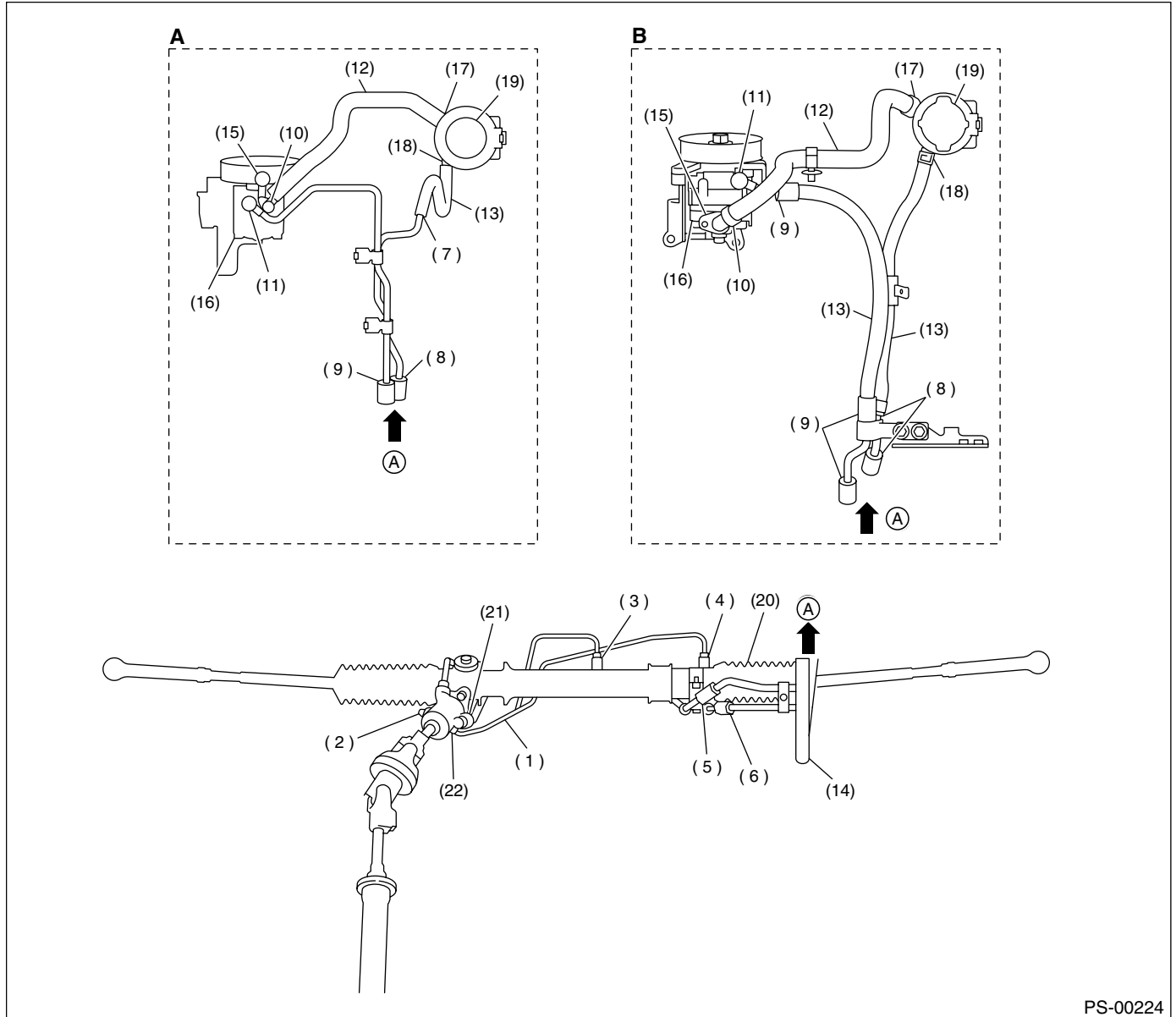

PS-00224

(A) 2.5 L model

(B) 3.0 L model

## PIPE ASSEMBLY

### POWER ASSISTED SYSTEM (POWER STEERING)

Fluid leaking area	Possible cause	Corrective action
Leakage from connecting portions of pipes and hoses, numbered with (1) through (11) in figure	Insufficient tightening of flare nut, catching dirt or the like, damage to flare or flare nut or eye bolt	Loosen and retighten, if ineffective, replace.
	Poor insertion of hose, poor clamping	Retighten or replace clamp.
	Damaged O-ring or gasket	Replace O-ring or gasket pipe or hose with new one, if ineffective, replace gearbox also.
Leakage from hose (12), (13) and (14) in figure	Crack or damage in hose	Replace with a new one.
	Crack or damage in hose hardware	Replace with a new one.
Leakage from surrounding of cast iron portion of oil pump (15) and (16) in figure	Damaged O-ring	Replace oil pump.
	Damaged gasket	Replace oil pump.
Leakage from oil tank (17) and (18) in figure	Crack in oil tank	Replace oil tank.
Leakage from filler neck (19)	Damaged cap packing	Replace cap.
	Crack in root of filler neck	Replace oil tank.
	High fluid level *1	Adjust fluid level.
Leakage from surrounding of power cylinder of gearbox (20) in figure	Damaged oil seal	Replace oil seal.
Leakage from control valve of gearbox (21) and (22) in figure	Damaged packing or oil seal	Replace problem parts.
	Damage in control valve	Replace control valve.

**NOTE:**

Fluid level is specified at optimum position (range) for ordinary use. Accordingly, if the vehicle is used often under hard conditions such as on very rough roads or in mountainous areas, fluid may bleed out from cap air vent hole. This is not a problem. If a customer complains strongly and is not likely to be satisfied with the leakage, lower the fluid level to the extent that fluid will not bleed out under the conditions described, and have the customer check the fluid level and its quality more frequency than usual.

# OIL PUMP

## POWER ASSISTED SYSTEM (POWER STEERING)

### 7. Oil Pump

#### A: REMOVAL

##### 1. 2.5 L MODEL

- 1) Remove ground cable from battery.
- 2) Remove pulley belt cover bracket.
- 3) Loosen lock bolt and slider bolt and remove power steering pump drive V-belt.

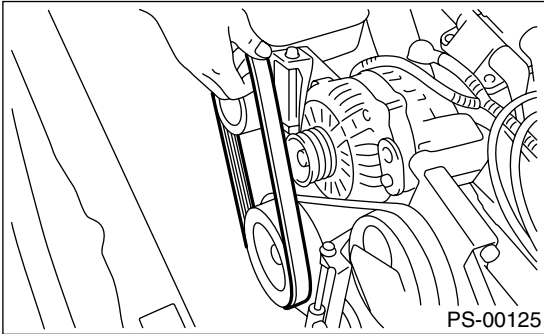

- 4) Disconnect connector from power steering pump switch.
- 5) Disconnect pipe C and suction hose from oil pump.

#### CAUTION:

- Do not allow fluid from the hose end to come into contact with pulley belt.
- To prevent foreign matter from entering the hose and pipe, cover the open ends of them with a clean cloth.

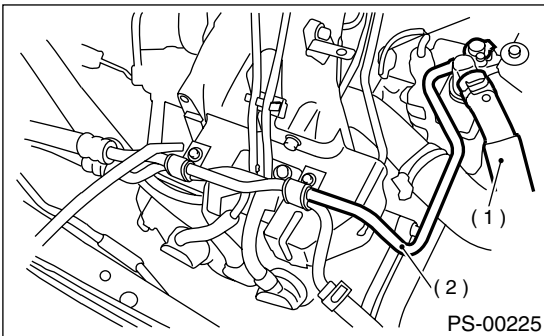

- (1) Suction hose
- (2) Pipe C

- 10) Disassemble oil pump and bracket by inserting a screwdriver as shown in the figure.

- 6) Remove bolts which install power steering pump bracket.

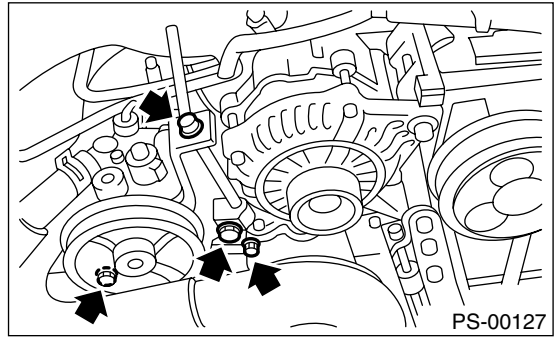

- 7) Place oil pump bracket in a vise, remove two bolts from the front side of oil pump.

#### CAUTION:

- Do not place oil pump bracket directly in the vise; use soft pads and hold oil pump lightly to protect the pump.

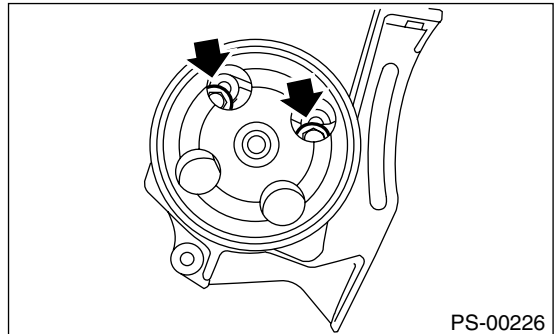

- 8) Remove socket from oil pump.

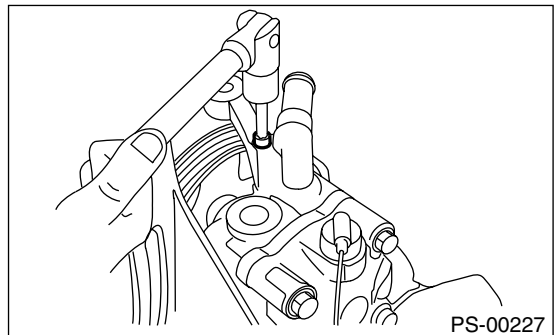

- 9) Remove bolt from the rear side of oil pump.

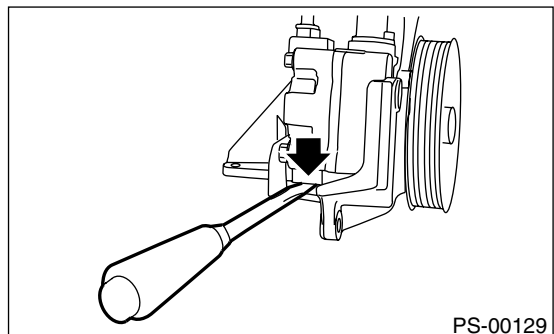

# OIL PUMP

## POWER ASSISTED SYSTEM (POWER STEERING)

### 2. 3.0 L MODEL

- 1) Remove ground cable from battery.
- 2) Remove pulley belt cover.
- 3) Remove V-belt.
- 4) Disconnect connector from power steering pressure switch.
- 5) Remove tensioner adjuster.
- 6) Disconnect pressure hose and suction hose from oil pump.

#### CAUTION:

- Do not allow fluid from the hose end to come into contact with pulley belt.
- To prevent foreign matter from entering the hose, cover the open ends of them with a clean cloth.

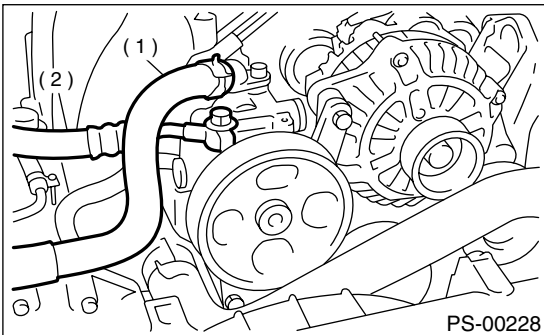

- (1) Pressure hose
- (2) Suction hose

- 7) Remove bolts, which install power steering pump bracket.

- 8) Place oil pump bracket in a vise, remove two bolts from the front side of oil pump.

#### CAUTION:

Do not place oil pump bracket directly in the vise; use soft pads and hold oil pump lightly to protect the pump.

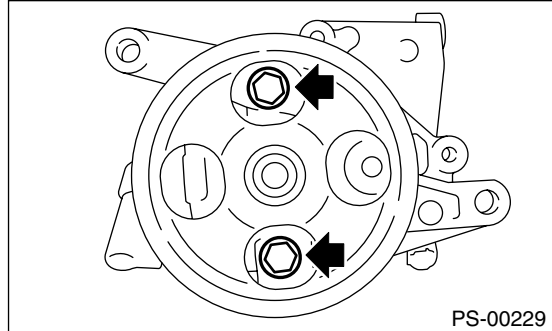

- 9) Remove bolt from the rear side of oil pump.

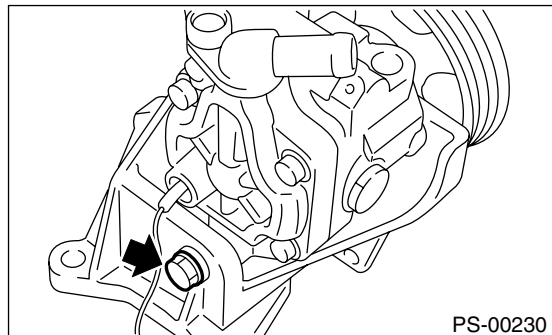

- 10) Remove oil pump from bracket.

# OIL PUMP

POWER ASSISTED SYSTEM (POWER STEERING)

## B: INSTALLATION

### 1. 2.5 L MODEL

1) Install oil pump to bracket.

(1) Place oil pump bracket in a vise. Tighten bushing using a 12.7 mm (1/2") type 14- and 21-mm box wrench until it is in contact with oil pump mounting surface.

#### CAUTION:

Do not place oil pump bracket directly in the vise; use soft pads and hold oil pump lightly to protect the pump.

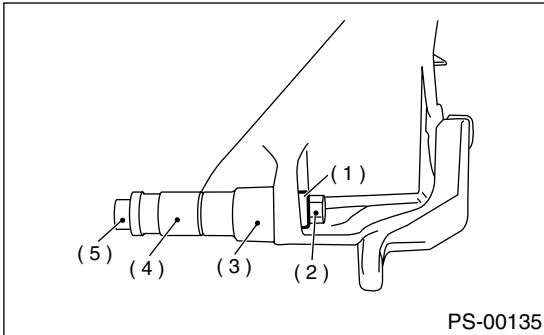

- (1) Bushing
- (2) Nut
- (3) 21 mm
- (4) 14 mm
- (5) Bolt

(2) Tighten bolt which installs oil pump and switch bracket to bracket.

#### Tightening torque:

**37.3 N·m (3.8 kgf·m, 27.5 ft·lb)**

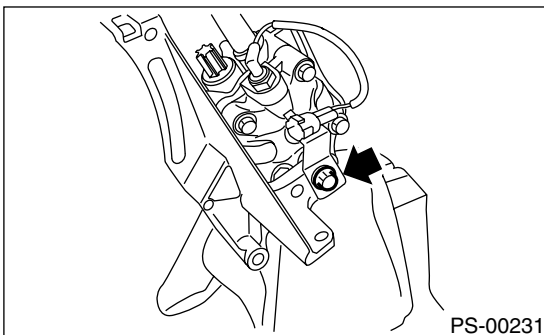

#### Tightening torque:

**15.7 N·m (1.6 kgf·m, 11.6 ft·lb)**

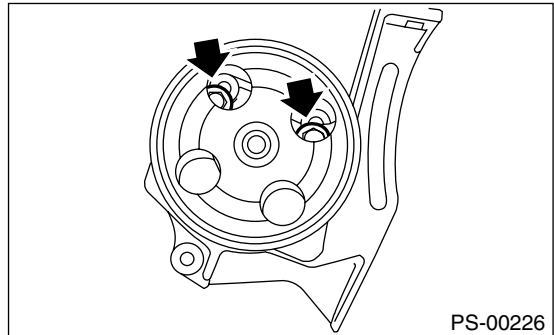

2) Install socket to oil pump.

#### Tightening torque:

**6.5 N·m (0.66 kgf·m, 4.8 ft·lb)**

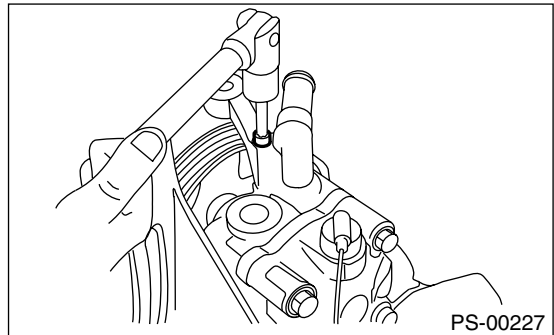

3) Tighten bolts which install power steering pump bracket.

#### Tightening torque:

**22 N·m (2.2 kgf·m, 15.9 ft·lb)**

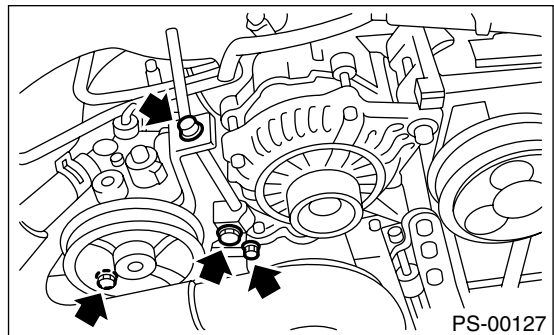

# OIL PUMP

## POWER ASSISTED SYSTEM (POWER STEERING)

4) Interconnect pipes C and suction hose.

### Tightening torque:

#### Joint nut

**39.2 N·m (4 kgf-m, 28.9 ft-lb)**

### CAUTION:

If a hose is twisted at this step, the hose may come into contact with some other parts.

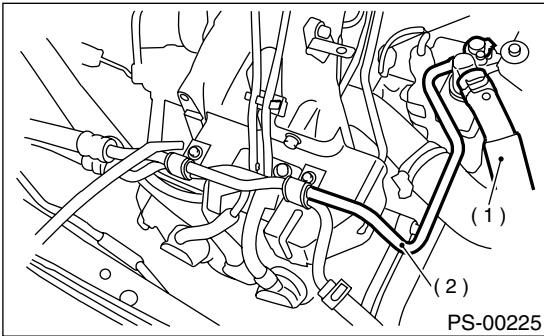

- (1) Suction hose
- (2) Pipe C

5) Connect connector to power steering oil pressure switch.

6) Install pulley belt to oil pump.

7) Check pulley belt tension. <Ref. to ME(H4SO)-43, V-belt.> and <Ref. to ME(H6DO)-28, V-belt.>

8) Tighten lock bolt.

### Tightening torque:

**24.5 N·m (2.5 kgf-m, 18.1 ft-lb)**

9) Tighten bolt belt tension.

### Tightening torque:

**8 N·m (0.8 kgf-m, 5.8 ft-lb)**

10) Install pulley belt cover bracket.

11) Connect ground terminal of battery.

12) Feed the specified power steering fluid <Ref. to PS-64, Power Steering Fluid.>

### CAUTION:

Never start the engine before feeding the fluid; otherwise vane pump might be seized up.

## 2. 3.0 L MODEL

1) Install oil pump to bracket.

- (1) Place oil pump bracket in a vise. Tighten bushing using a 12.7 mm (1/2") type 14 and 21-mm box wrench until it is in contact with oil pump mounting surface.

### CAUTION:

Do not place oil pump bracket directly in the vise; use soft pads and hold oil pump lightly to protect the pump.

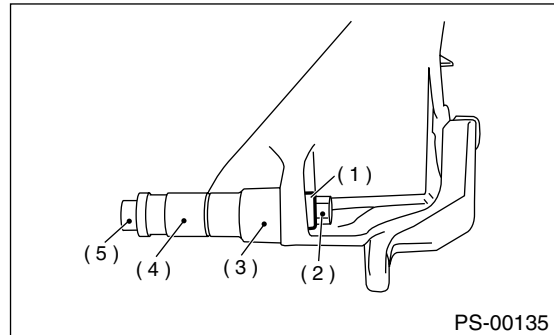

- (1) Bushing
- (2) Nut
- (3) 21 mm
- (4) 14 mm
- (5) Bolt

(2) Tighten bolt which installs oil pump to bracket.

### Tightening torque:

**15.7 N·m (1.6 kgf-m, 11.6 ft-lb)**

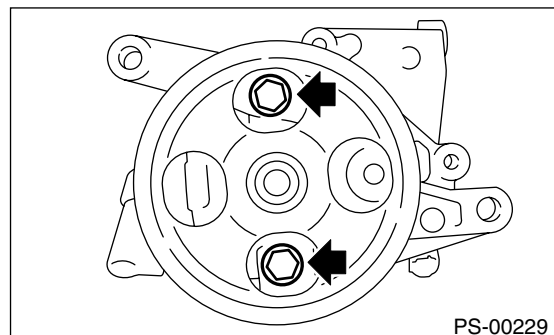

### Tightening torque:

**37.3 N·m (3.8 kgf-m, 27.5 ft-lb)**

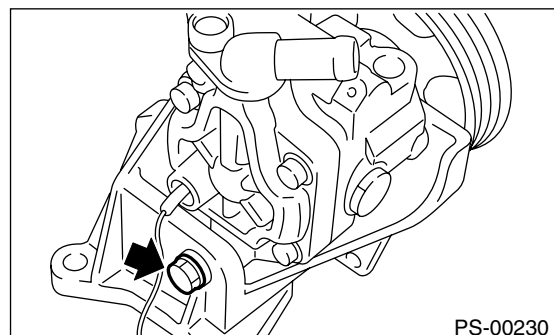

# OIL PUMP

POWER ASSISTED SYSTEM (POWER STEERING)

2) Tighten bolts which install power steering pump bracket.

**Tightening torque:**

**33.3 N·m (3.4 kgf-m, 24.5 ft-lb)**

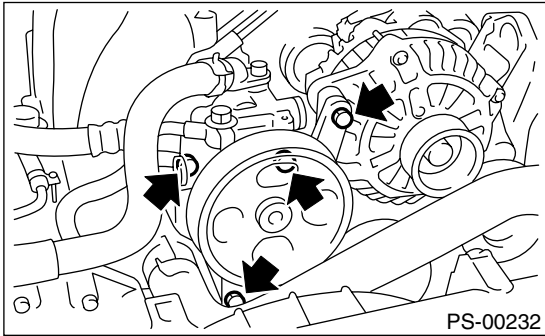

3) Interconnect pressure hose and suction hose.

**Tightening torque:**

**Eye bolt**

**39.2 N·m (4 kgf-m, 28.9 ft-lb)**

**CAUTION:**

If a hose is twisted at this step, the hose may come into contact with some other parts.

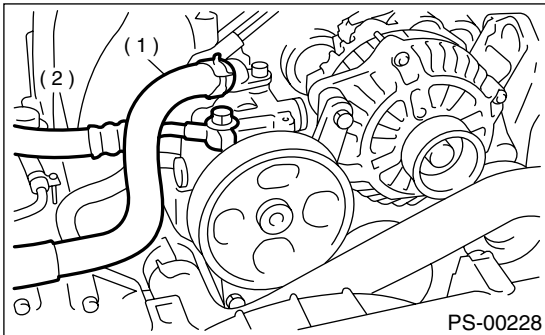

- (1) Suction hose
- (2) Pressure hose

4) Connect connector to power steering oil pressure switch.

5) Install tensioner adjuster.

6) Install V-belt.

7) Install pulley belt cover.

8) Connect ground terminal of battery.

9) Feed the specified power steering fluid. <Ref. to PS-64, Power Steering Fluid.>

**CAUTION:**

Never start the engine before feeding the fluid; otherwise vane pump might be seized up.

## C: DISASSEMBLY

**NOTE:**

Oil pump for TURBO model and 3.0 L model cannot be disassembled. If the oil pump is malfunctioning, replace the oil pump as an assembly.

1) Using ST, place oil pump in a vise and remove four bolts which secure rear cover.

ST 34199AE020 ATTACHMENT

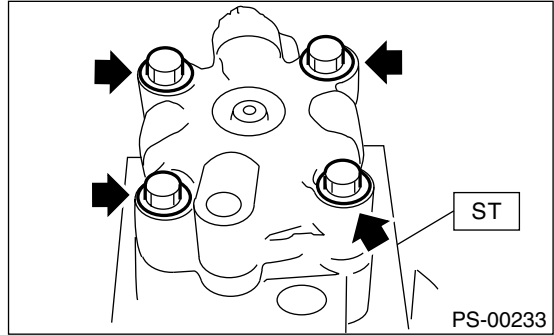

2) Remove pressure plate.

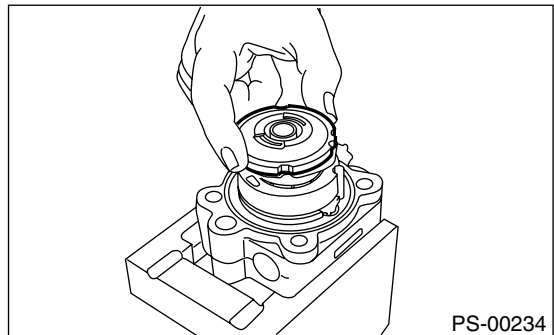

3) Using a screwdriver, pry retaining ring off.

**CAUTION:**

Do not remove cam ring, rotor, etc.

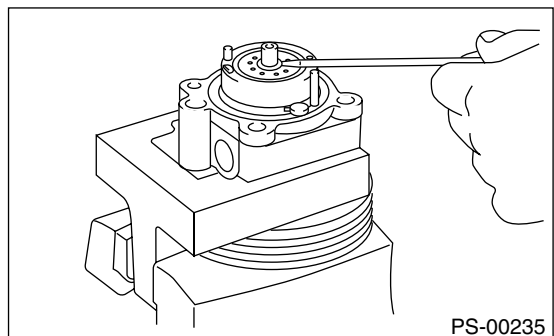

4) Install pressure plate.

5) Temporarily install rear cover to front casing.

# OIL PUMP

## POWER ASSISTED SYSTEM (POWER STEERING)

6) Remove oil pump pulley.

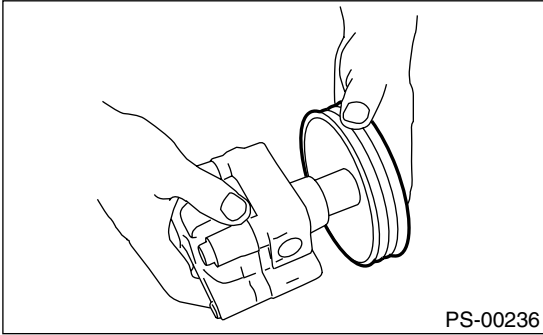

7) Place oil pump in a vise.

**CAUTION:**

**Do not place oil pump directly in the vise, use soft pads and hold oil pump lightly to protect the pump.**

8) Pry oil seal off using a screwdriver.

**CAUTION:**

**Be careful not to scratch inner surface of casing.**

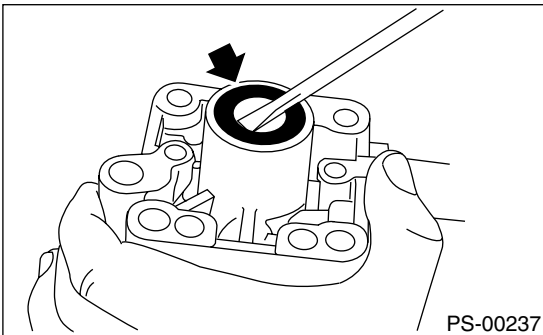

## D: ASSEMBLY

1) Reassembly precautions

(1) Whenever O-rings, oil seals, and snap rings are removed, they must be replaced with new ones.

(2) Thoroughly wash parts and allow to dry. They must be kept free from cleaning oil and dust.

(3) Reassembly procedure must be performed in clean place. Ensure that parts are kept away from waste threads or other dust particles.

(4) Cleaning oil tends to stay inside the front casing. Remove it completely by blowing compressed air.

(5) Ensure that parts are free from rust. (Use specified hydraulic oil for rust prevention after cleaning and drying.)

(6) Reverse the sequence of disassembly procedures.

2) Apply grease to oil seal and inner surface of front casing (at bearing location).

**CAUTION:**

**Make sure that the front body internal surfaces are free from damage.**

3) Temporarily install rear cover to front body.

4) Attach ST to front body. Using a press, install oil seal.

ST 34199AE030 INSTALLER

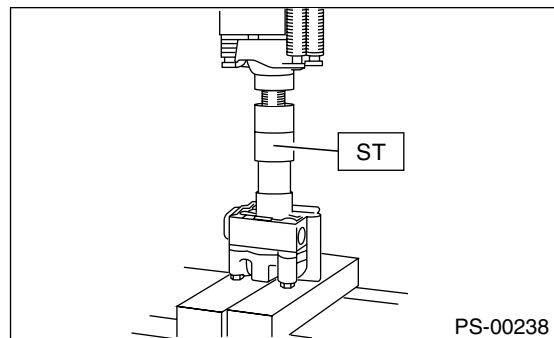

5) Install pump pulley to front body.

6) Using ST, place oil pump in a vise.

ST 34199AE020 ATTACHMENT

7) Remove rear cover.



# OIL PUMP

## POWER ASSISTED SYSTEM (POWER STEERING)

8) Using 10-mm box wrench, tap retaining ring into shaft groove.

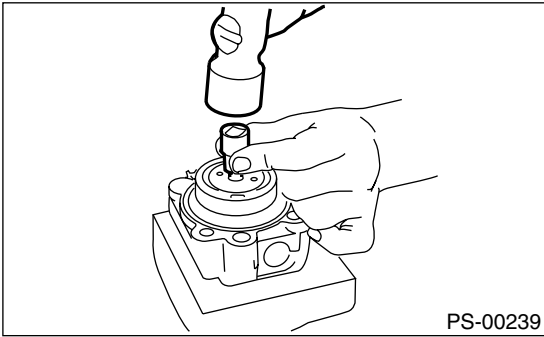

9) Install pressure plate as shown in the figure.

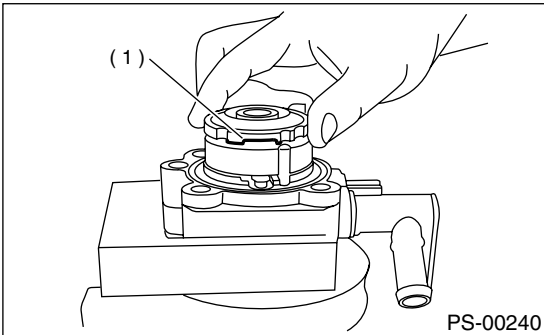

(1) Groove

10) Apply specified hydraulic oil to O-rings and fit them into front casing and pressure plate.

11) Install seal ring to pressure plate.

12) With knock pin positions aligned, install rear cover.

### **Tightening torque:**

**27.5 N·m (2.8 kgf·m, 20.3 ft·lb)**

### **CAUTION:**

**Loosely tighten bolts in the sequence (A), (B), (C), and (D) shown in figure. Then, tighten in the same sequence.**

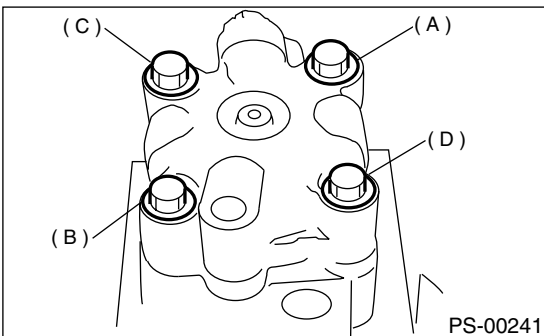

13) When reassembly procedures have been completed, turn shaft by hand to ensure it turns smoothly. If it binds or other unusual conditions are evident, disassemble again and check for foreign

matter trapped on sliding surfaces and improper installation. Eliminate the cause of trouble.

14) Check followings by referring to "CHECK" article.

- Excessive play in pulley shaft
- Ditch deflection of pulley
- Resistance to rotation of pulley
- Measurement of generated oil pressure

# OIL PUMP

## POWER ASSISTED SYSTEM (POWER STEERING)

### E: INSPECTION

#### 1. BASIC INSPECTION

Perform the following inspection procedures and repair or replace defective parts.

Part name	Description	Remedy
1. Front casing	1) Damage on body surfaces 2) Excessive wear on hole, into which spool valve is inserted. 3) Wear and damage on cartridge assembly mounting surface 4) Wear and damage on surfaces in contact with shaft and oil seal	Replace with a new one together with spool valve as selective fit is made.
2. Rear cover	1) Damage on body surfaces 2) Wear and damage on sliding surfaces	Replace with a new one.
3. Shaft	1) Shaft bend 2) Wear and damage on surfaces in contact with bushing and oil seal 3) Wear and damage on rotor mounting surfaces 4) Bearing damage	Replace with a new one.
4. Pressure plate	Wear and damage on sliding surfaces	Replace with a new one.
5. Cam ring	Ridge wear on sliding surfaces	If damage is serious, replace with a new cartridge assembly.
6. Vane	Excessive wear on nose radius and side surfaces	
7. Rotor	1) Wear and damage on sliding surfaces 2) Ridge wear on vane sliding grooves (If light leaks with vane in slit against light source) 3) Damage resulting from snap ring removal	
8. Connector	Damage on threads	Correct with oil stone. If damage is serious, replace with a new cartridge assembly.
9. Spring	Damage	Replace with a new one.
10. Bolts and nuts	Damage on threads	Replace with a new one.

• In accordance with the following table, check all removed parts for wear and damage, and make repair or replacement if necessary.

No.	Parts	Inspection	Corrective action
1	Oil pump (Exterior)	(1) Crack, damage or oil leakage	Replace oil pump with a new one.
		(2) Play of pulley shaft	Measure radial play and axial play. If any of these exceeds the service limit, replace oil pump with a new one.
2	Pulley	(1) Damage	Replace it with a new one.
		(2) Bend	Measure V ditch deflection. If it exceeds the service limit, replace pulley with a new one.
3	Oil pump (Interior)	(1) Defect or burning of vane pump	Check resistance to rotation of pulley. If it is past the service limit, replace oil pump with a new one.
		(2) Bend in the shaft or damage to bearing	Oil pump emits a noise that is markedly different in tone and loudness from a sound of a new oil pump when turning with a string put around its pulley, replace oil pump with a new one.
4	O-ring	Crack or deterioration	Replace it with a new one.
5	Bracket	Crack	Replace it with a new one.

# OIL PUMP

POWER ASSISTED SYSTEM (POWER STEERING)

## 2. SERVICE LIMIT

Make a measurement as follows. If it exceeds the specified service limit, replace the parts with new ones.

### CAUTION:

- Fix oil pump on a vise to make a measurement. At this time, hold oil pump with the least possible force between two wood pieces.
- Do not set outside of flow control valve or pulley on a vise; otherwise outside or pulley might be deformed. Select properly sized wood pieces.

1) Play of pulley shaft

**On condition:**

**P: 9.8 N (1.0 kgf, 2.2 lb)**

**Service limit:**

**Radial play (Direction  $\longleftrightarrow$ )**  
**0.4 mm (0.016 in) or less**

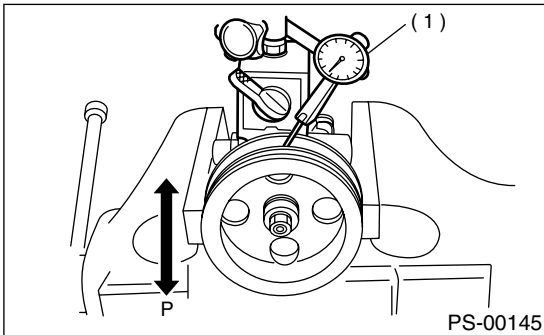

(1) Dial indicator

**Axial play (Direction  $\longleftrightarrow$ )**  
**0.6 mm (0.024 in) or less**

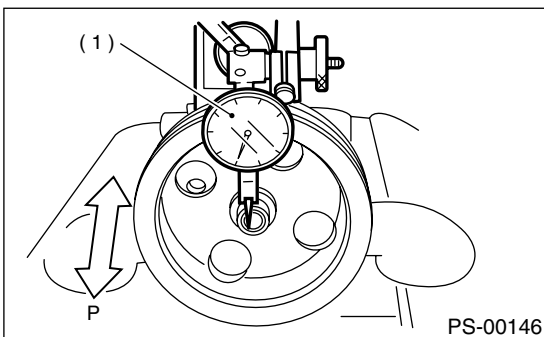

(1) Dial indicator

2) Ditch deflection of pulley

**Service limit:**

**1.0 mm (0.039 in) or less**

**NOTE:**

Read the value for one surface of V ditch, and then the value for another off the dial.

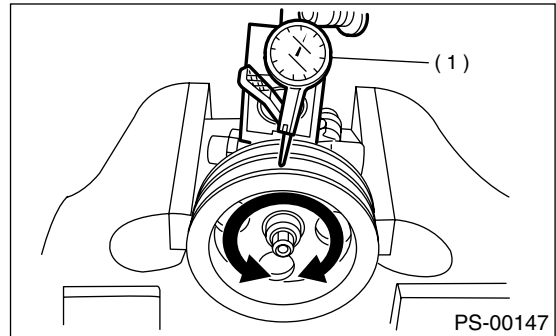

(1) Dial indicator

3) Resistance to rotation of pulley

**Service limit:**

**Maximum load; 9.22 N (0.94 kgf, 2.07 lb) or less**

**NOTE:**

- A rather higher value may be indicated when pulley starts turning.
- Measure the load during rotation and make a judgment.

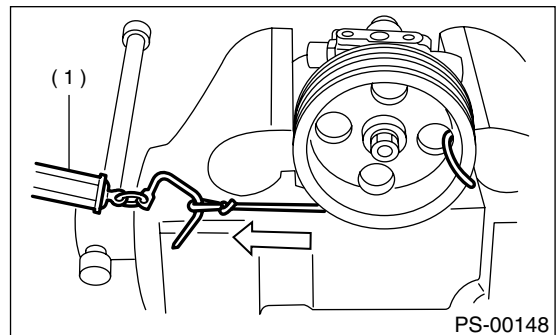

(1) Spring balance

# OIL PUMP

## POWER ASSISTED SYSTEM (POWER STEERING)

### 3. HYDRAULIC PRESSURE

#### CAUTION:

- Be sure to complete all items aforementioned in "INSPECTION", prior to measuring hydraulic pressure. Otherwise, pressure can not be measured correctly. <Ref. to PS-66, INSPECTION, General Diagnostic Table.>
- Do not leave the valve of pressure gauge closed or hold the steering wheel at stop end for 5 seconds or more in any case, as the oil pump may be damaged due to long keep of these conditions.
- Put cotton cloth waste at a place where fluid drops before pressure gauge is installed. Wipe off split fluid thoroughly after the measurement.

#### NOTE:

Keep engine idling during the measurement.

#### 1) REGULAR PRESSURE MEASUREMENT

- (1) Connect ST1, ST2 and ST3.

ST1 92511000 PRESSURE GAUGE

ST2 34099AC020 ADAPTER HOSE B

ST3 34099AC010 ADAPTER HOSE A

- (2) Disconnect pressure hose from the pump.
- (3) Using gasket (Part No. 34621AC021) and bolt (Part No. 34620AC010), instal ST2 to the pump instead of pressure hose.

#### 2.5 L model:

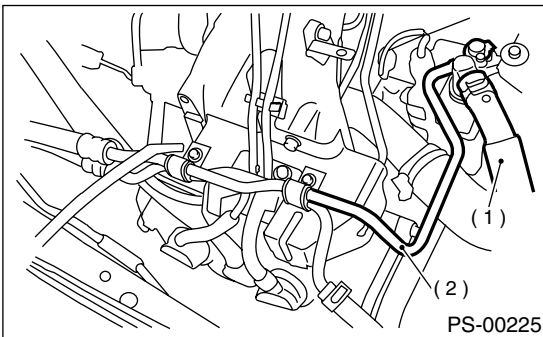

- (1) Suction hose
- (2) Pressure hose

#### 3.0 L model:

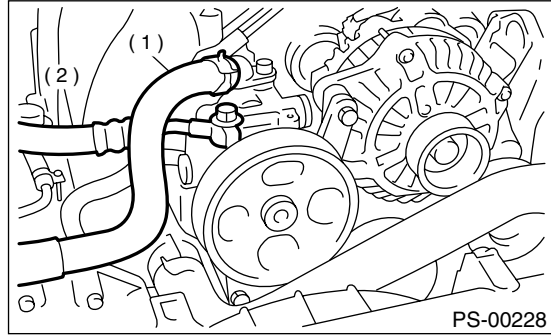

- (1) Suction hose
- (2) Pressure hose

- (4) Disconnect pipe C form pipe (on gearbox side).

- (5) Install ST3 to pipe C.

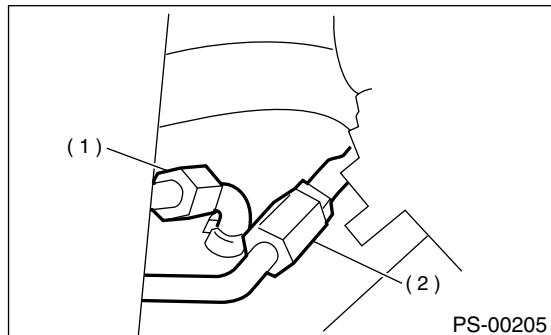

- (1) Pipe C
- (2) Pipe D

- (6) Replenish power steering fluid up to specified level.

- (7) Open valve, and start the engine.

- (8) Measure regular pressure.

ST1 925711000 PRESSURE GAUGE

ST2 34099AC020 ADAPTER HOSE B

ST3 34099AC010 ADAPTER HOSE A

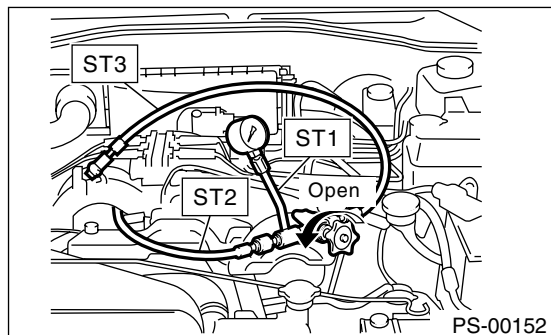

#### Service limit:

981 kPa (10 kg/cm<sup>2</sup>, 142 psi) or less

# OIL PUMP

POWER ASSISTED SYSTEM (POWER STEERING)

(9) If it is not within the specified value, replace the troubled part caused by the following symptoms; pipe or hose clogged, leaks from fluid line, and mix of foreign objects in fluid line.

2) Measure relief pressure.

- (1) Using STs, measure relief pressure.
- (2) Close valve.
- (3) Measure relief pressure.

ST1 925711000 PRESSURE GAUGE  
ST2 34099AC020 ADAPTER HOSE B  
ST3 34099AC010 ADAPTER HOSE A

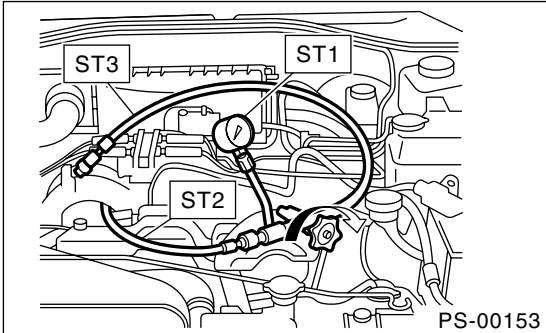

**Service limit:**

**2.5 L model**

**9,611 — 10,199 kPa (98 — 104 kg/cm<sup>2</sup>,  
1,394 — 1,479 psi)**

**TURBO model and 3.0 L model**

**7,650 — 8,340 kPa (78.03 — 88.13 kg/cm<sup>2</sup>,  
1,109 — 1,209 psi)**

(4) If it is not within the specified value, replace the oil pump.

3) Measure working pressure.

- (1) Using STs, measure working pressure.
- (2) Open valve.
- (3) Measure working pressure of control valve by turning wheel from stop to stop.

ST1 925711000 PRESSURE GAUGE  
ST2 34099AC020 ADAPTER HOSE B  
ST3 34099AC010 ADAPTER HOSE A

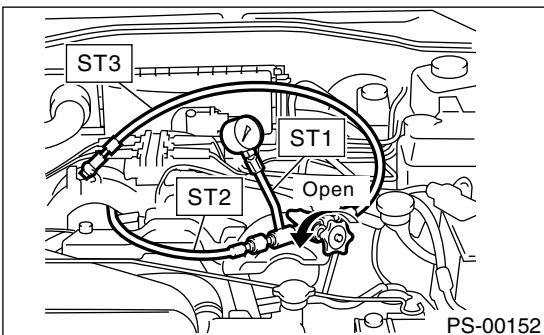

**Service limit:**

**2.5 L model**

**9,611 — 10,199 kPa (98 — 104 kg/cm<sup>2</sup>,  
1,394 — 1,479 psi)**

**TURBO model and 3.0 L model**

**7,650 — 8,340 kPa (78.03 — 88.13 kg/cm<sup>2</sup>,  
1,109 — 1,209 psi)**

(4) If it is within the specified value, measure steering effort. <Ref. to PS-69, MEASUREMENT OF STEERING EFFORT, INSPECTION, General Diagnostic Table.> If it is not within specified value, replace control valve itself or control valve and pinion as a single unit with new ones.

# RESERVOIR TANK

POWER ASSISTED SYSTEM (POWER STEERING)

## 8. Reservoir Tank

### A: REMOVAL

#### 1. 2.5 L MODEL

- 1) Drain fluid from the reservoir tank.
- 2) Disconnect pipe D from return hose and suction hose from oil pump.

#### CAUTION:

- Do not allow fluid from the hose end to come into contact with pulley belt.
- To prevent foreign matter from entering the hose and pipe, cover the open ends of them with a clean cloth.

Non-TURBO model

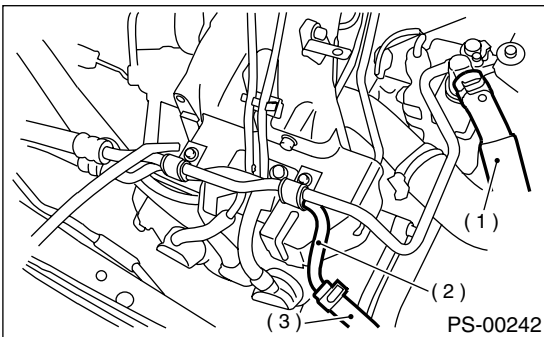

TURBO model

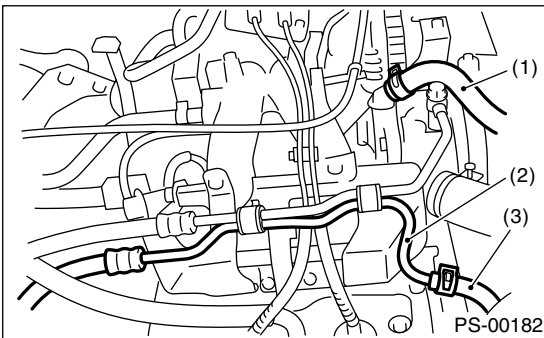

- (1) Suction hose
- (2) Pipe D
- (3) Return hose

- 3) Remove reservoir tank from bracket by pulling it upwards.

#### 2. 3.0 L MODEL

- 1) Drain fluid from the reservoir tank.
- 2) Disconnect return hose and suction hose from reservoir tank.

### B: INSTALLATION

#### 1. 2.5 L MODEL

- 1) Install reservoir tank to bracket.
- 2) Connect pipes D to return hose and suction hose to oil pump.

Non-TURBO model

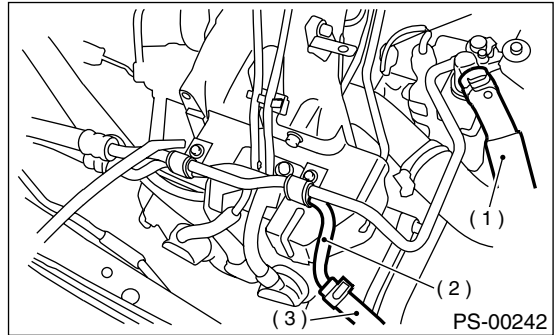

TURBO model

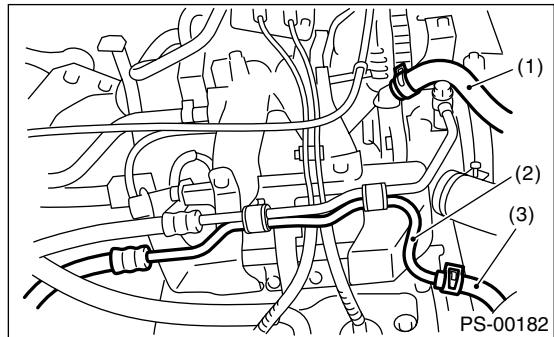

- (1) Suction hose
- (2) Pipe D
- (3) Return hose

- 3) Feed the specified power steering fluid. <Ref. to PS-64, Power Steering Fluid.>

#### 2. 3.0 L MODEL

- 1) Install reservoir tank to bracket.
- 2) Connect return hose and suction hose to reservoir tank.

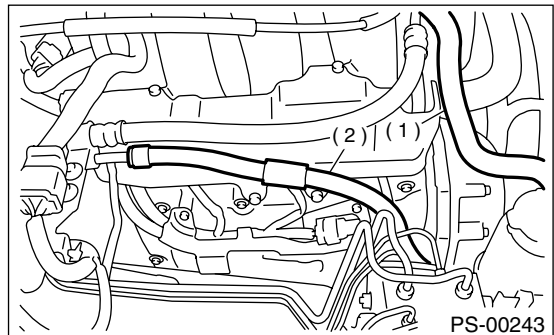

- (1) Suction hose
- (2) Return hose

## RESERVOIR TANK

POWER ASSISTED SYSTEM (POWER STEERING)

---

3) Feed the specified power steering fluid. <Ref. to PS-64, Power Steering Fluid.>

### **C: INSPECTION**

Check reservoir tank for cracks, breakage, or damage. If any cracks, breakage, or damage is found, replace reservoir tank.

# POWER STEERING FLUID

POWER ASSISTED SYSTEM (POWER STEERING)

## 9. Power Steering Fluid

### A: SPECIFICATION

Recommended power steering fluid	Manufacturer
DEXRON III or equivalent	B.P.
	CALTEX
	CASTROL
	MOBIL
	SHELL
	TEXACO

### B: INSPECTION

1) Check power steering fluid for deterioration or contamination. If the fluid is highly deteriorated or contaminated, drain it and refill with new fluid.

2) Check joints and units for oil leakage. If any oil leaks are found, repair or replace the applicable part.

3) Inspect fluid level on flat and level surface with engine "OFF" by indicator of reservoir tank.

If the level is at lower point or below, add fluid to keep the level in the specified range of the indicator. If at upper point or above, drain fluid by using a syringe or the like.

(1) Check at temperature 20°C (68°F) on reservoir surface of oil pump; read the fluid level on the "COLD" side.

(2) Check at temperature 80°C (176°F) on reservoir surface of oil pump; read the fluid level on the "HOT" side.

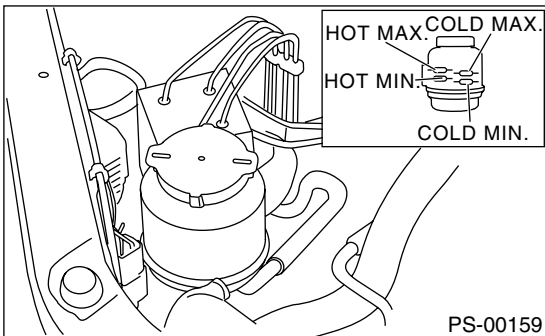

### C: INSTALLATION

1) Set ST on top of reservoir tank and fill it about half way with the specified fluid.

ST 34199AE040 OIL CHARGE GUIDE

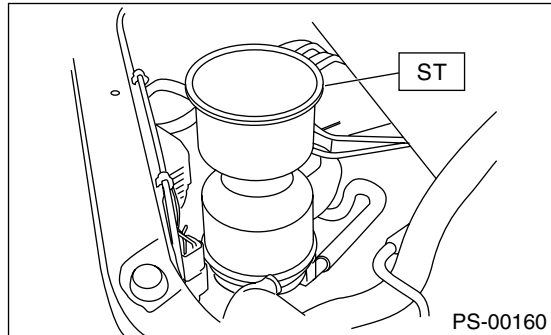

2) Jack-up vehicle and support it with safety stands, then turn steering wheel with engine stopped.

3) Continue to turn steering wheel slowly from lock to lock until bubbles stop appearing in the tank while keeping the fluid at that level.

4) In case air is absorbed to deliver bubbles into piping because the fluid level is lower, leave it about half an hour and then do the step 2) all over again.

5) Start and idle the engine.

6) Continue to turn steering wheel slowly from lock to lock again until bubbles stop appearing in the tank while keeping the fluid at that level.

It is normal that bubbles stop appearing after three times turning of steering wheel.

7) In case bubbles do not stop appearing in the tank, leave it about half an hour and then do the step 5) all over again.

8) Stop the engine, and take out safety stands after jacking up vehicle again.

Then lower the vehicle, and idle the engine.

9) Continue to turn steering wheel from lock to lock until bubbles stop appearing and change of the fluid level is within 3 mm (0.12 in).

10) In case the following happens, leave it about half an hour and then do step 8) again.

(1) The fluid level changes over 3 mm (0.12 in).

(2) Bubbles remain on the upper surface of the fluid.

(3) Grinding noise is generated from oil pump.

11) Check the fluid leakage at flare nuts after turning steering wheel from lock to lock with engine running.

#### CAUTION:

- Before checking, wipe off any fluid on flare nuts and piping.

- In case the fluid leaks from flare nut, it is caused by dust (or the like) and/or damage between flare and tapered seat in piping.



## **POWER STEERING FLUID**

POWER ASSISTED SYSTEM (POWER STEERING)

---

- Remove the flare nut and tighten again it to the specified torque after cleaning flare and tapered seat. If flare or tapered seat is damaged, replace with a new one.

# GENERAL DIAGNOSTIC TABLE

## POWER ASSISTED SYSTEM (POWER STEERING)

### 10. General Diagnostic Table

#### A: INSPECTION

Trouble	Possible cause	Corrective action
<ul style="list-style-type: none"> <li>• Heavy steering effort in all ranges</li> <li>• Heavy steering effort at stand still</li> <li>• Steering wheel surges when turning.</li> </ul>	1. Pulley belt <ul style="list-style-type: none"> <li>• Unequal length of pulley belts</li> <li>• Adhesion of oil and grease</li> <li>• Loose or damage of pulley belt</li> <li>• Poor uniformity of pulley belt cross section</li> <li>• Pulley belt touches to pulley bottom</li> <li>• Poor revolution of pulleys except oil pump pulley</li> <li>• Poor revolution of oil pump pulley</li> </ul>	Adjust or replace.
	2. Tire and rim <ul style="list-style-type: none"> <li>• Improper tires out of specification</li> <li>• Improper rims out of specification</li> <li>• Tires not properly inflated*1</li> </ul>	Replace or reinflate.
	3. Fluid <ul style="list-style-type: none"> <li>• Low fluid level</li> <li>• Aeration</li> <li>• Dust mix</li> <li>• Deterioration of fluid</li> <li>• Poor warming-up of fluid *2</li> </ul>	Refill, bleed air, replace or instruct customer.
	4. Idling speed <ul style="list-style-type: none"> <li>• Lower idling speed</li> <li>• Excessive drop of idling speed at start or at turning steering wheel *3</li> </ul>	Adjust or instruct customer.
	5. Measure hydraulic pressure.<Ref. to PS-58, INSPECTION, Oil Pump.>	Replace problem parts.
	6. Measure steering effort.<Ref. to PS-66, INSPECTION, General Diagnostic Table.>	Adjust or replace.
<ul style="list-style-type: none"> <li>• Vehicle leads to one side or the other.</li> <li>• Poor return of steering wheel to center</li> <li>• Steering wheel surges when turning.</li> </ul>	1. Fluid line <ul style="list-style-type: none"> <li>• Folded hose</li> <li>• Flattened pipe</li> </ul>	Reform or replace.
	2. Tire and rim <ul style="list-style-type: none"> <li>• Flat tire</li> <li>• Mix use of different tires</li> <li>• Mix use of different rims</li> <li>• Abnormal wear of tire</li> <li>• Unbalance of remained grooves</li> <li>• Unbalance of tire pressure</li> </ul>	Fix or replace.
	3. Front alignment <ul style="list-style-type: none"> <li>• Improper or unbalance caster</li> <li>• Improper or unbalance toe-in</li> <li>• Loose connection of suspension</li> </ul>	Adjust or retighten.
	4. Others <ul style="list-style-type: none"> <li>• Damaged joint assembly</li> <li>• Unbalanced height</li> <li>• One-sided weight</li> </ul>	Replace, adjust or instruct customer.
	5. Measure steering effort.<Ref. to PS-66, INSPECTION, General Diagnostic Table.>	Adjust or replace.

\*1 If tires and/or rims are wider, the load to power steering system is the more. Accordingly, in a condition, for example before fluid warms-up, relief valve may work before maximum turning angle. In this case, steering effort may be heavy. When measured hydraulic pressure is normal, there is no abnormal thing.

\*2 In cold weather, steering effort may be heavy due to increased flow resistance of cold fluid. After warming-up engine, turn steering wheel from stop to stop several times to warm-up fluid. Then if steering effort reduces normally, there is no abnormal thing.

\*3 In cold weather or with insufficient warm-up of engine, steering effort may be heavy due to excessive drop of idling when turning steering wheel. In this case, it is recommended to start the vehicle with increasing engine speed than usual. Then if steering effort reduces normally, there is no abnormal thing.

# GENERAL DIAGNOSTIC TABLE

POWER ASSISTED SYSTEM (POWER STEERING)

## 1. NOISE AND VIBRATION

### CAUTION:

**Don't keep the relief valve operated over 5 seconds at any time or inner parts of the oil pump may be damaged due to rapid increase of fluid temperature.**

### NOTE:

- Grinding noise may be heard immediately after the engine start in extremely cold condition. In this case, if the noise goes off during warm-up there is no abnormal function in the system. This is due to the fluid characteristic in extremely cold condition.
- Oil pump makes whine or growl noise slightly due to its mechanism. Even if the noise can be heard when steering wheel is turned at stand still there is no abnormal function in the system provided that the noise eliminates when the vehicle is running.
- When stopping with service brake and/or parking brake applied, power steering can be operated easily due to its light steering effort. If doing so, the disk rotates slightly and makes creaking noise. The noise is generated by creaking between the disk and pads. If the noise goes off when the brake is released, there is no abnormal function in the system.

• There may be a little vibration around the steering devices when turning steering wheel at standstill, even though the component parts are properly adjusted and have no defects.

Hydraulic systems are likely to generate this kind of vibration as well as working noise and fluid noise because of combined conditions, i.e., road surface and tire surface, engine speed and turning speed of steering wheel, fluid temperature and braking condition.

This phenomena does not indicate there is some abnormal function in the system.

The vibration can be known when steering wheel is turned repeatedly at various speeds from slow to rapid step by step with parking brake applied on concrete road and in "D" range for automatic transmission vehicle.

Trouble	Possible cause	Corrective action
Hiss noise (continuous) While engine is running.	Relief valve emits operating sound when steering wheel is completely turned in either direction. (Don't keep this condition over 5 seconds.)	Normal
	Relief valve emits operating sound when steering wheel is not turned. This means that the relief valve is faulty.	Defective Replace oil pump.
Rattling noise (intermittent) While engine is running.	Interference with adjacent parts	Check clearance. Correct if necessary. <Ref. to PS-48, INSPECTION, Pipe Assembly.>
	Loosened installation of oil pump, oil tank, pump bracket, gearbox or crossmember	Retighten.
	Loosened installation of oil pump pulley or other pulley(s)	Retighten.
	Loosened linkage or play of steering or suspension Loosened tightening of joint or steering column	Retighten or replace.
	Sound generates from the inside of gearbox or oil pump.	Replace bad parts of the gearbox or oil pump.
Knocking When turning steering wheel in both direction with small angle repeatedly at engine ON or OFF.	Excessive backlash Loosened lock nut for adjusting backlash	Adjust and retighten.
	Loosened tightening or play of tie-rod, tie-rod end	Retighten or replace.
Grinding noise (continuous) While engine is running.	Vane pump aeration	Inspect and retighten fluid line connection. Refill fluid and vent air.
	Vane pump seizing	Replace oil pump.
	Pulley bearing seizing of oil pump	Replace oil pump.
	Folded hose, flat pipe	Replace.
Squeal, squeak (intermittent or continuous) While engine is running.	Maladjustment of pulley belt Damaged or charged pulley belt Unequal length of pulley belts	Adjust or replace. (Replace two belts as a set.)
	Run out or soilage of V-groove surface of oil pump pulley	Clean or replace.

## GENERAL DIAGNOSTIC TABLE

### POWER ASSISTED SYSTEM (POWER STEERING)

Trouble	Possible cause	Corrective action
Sizzling noise (continuous) While engine is running.	Fluid aeration	Fix wrong part causing aeration. Replace fluid and vent air.
	Damaged pipe of gearbox	Replace pipe.
	Abnormal inside of hose or pipe Flat hose or pipe	Rectify or replace.
	Abnormal inside of oil tank	Replace.
	Removed oil tank cap	Install cap.
Whistle (continuous) While engine is running.	Abnormal pipe of gearbox or abnormal inside of hose	Replace bad parts of gearbox or hose.
Whine or growl (continuous or intermittent) While engine is running with/ without steering turned.	Loosened installation of oil pump, oil pump bracket	Retighten.
	Abnormal inside of oil pump, hose	Replace oil pump, hose, if the noise can be heard when running as well as stand still.
	Torque converter growl, air conditioner compression growl	Remove power steering pulley belt and confirm.
Creaking noise (intermittent) While engine is running with steering turned.	Abnormal inside of gearbox	Replace bad parts of gearbox.
	Abnormal bearing for steering shaft	Apply grease or replace.
	Generates when turning steering wheel with brake (service or parking) applied.	If the noise goes off when brake is released, it is normal.
Vibration While engine is running with/ without steering turned.	Too low engine speed at start	Adjust and instruct customers.
	Vane pump aeration	Fix wrong part. Vent air.
	Damaged valve in oil pump, gearbox	Replace oil pump, bad parts of gearbox.
	Looseness of play of steering, suspension parts	Retighten.

# GENERAL DIAGNOSTIC TABLE

POWER ASSISTED SYSTEM (POWER STEERING)

## 2. MEASUREMENT OF STEERING EFFORT

Step	Check	Yes	No
<b>1 CHECK STEERING EFFORT.</b> 1) Stop the vehicle on a concrete road. 2) Start the engine. 3) Idle the engine. 4) Install spring scale on the steering wheel. 5) Pull spring scale at an right angle to the steering wheel, and measure both right and left steering wheel effort.  NOTE: When turning steering more quickly than necessary from a direction to the other direction at an engine speed over 2,000 rpm, steering effort may be heavy. This is caused by flow characteristic of oil pump and is not a problem.	Is the steering effort less than 29.4 N (3.0 kgf, 6.6 lb)?	Go to step 2.	Adjustment backlash.
<b>2 CHECK STEERING EFFORT.</b> 1) Stop the engine. 2) Pull spring scale at an right angle to the steering wheel, and measure both right and left steering wheel effort.	Is the steering effort less than 29.4 N (3.0 kgf, 6.6 lb)?	Go to step 3.	Adjustment.
<b>3 CHECK STEERING WHEEL EFFORT.</b> 1) Remove universal joint. 2) Measure steering wheel effort.	Is the maximum force steering wheel effort less than 2.26 N (0.23 kgf, 0.51 lb)?	Go to step 4.	Check, adjust and replace if necessary.
<b>4 CHECK STEERING WHEEL EFFORT.</b> Measure steering wheel effort.	Is the fluctuation width less than 1.08 N (0.11 kgf, 0.24 lb)?	Go to step 5.	Check, adjust and replace if necessary.
<b>5 CHECK UNIVERSAL JOINT.</b> Measure folding torque of the joint (short yoke). <Ref. to PS-20, INSPECTION, Universal Joint.>	Is the fluctuation width less than 8.43 N (0.86 kgf, 1.90 lb)?	Go to step 6.	Replace with new one.
<b>6 CHECK UNIVERSAL JOINT.</b> Measure folding torque of the joint (long yoke). <Ref. to PS-20, INSPECTION, Universal Joint.>	Is the folding torque less than 5.49 N (0.56 kgf, 1.23 lb)?	Go to step 7.	Replace with new one.
<b>7 CHECK FRONT WHEEL.</b>	Are there unsteady revolution or rattling of front wheels and dragging of brake?	Inspect, readjust and replace if necessary.	Go to step 8.
<b>8 CHECK TIE-ROD ENDS.</b> Remove the tie-rod ends.	Are there unsteady revolution or rattling of tie-rod ends of suspension?	Inspect and replace if necessary.	Go to step 9.
<b>9 CHECK BALL JOINT.</b>	Are there unsteady revolution or rattling of ball joints of suspension?	Inspect and replace if necessary.	Go to step 10.
<b>10 CHECK GEARBOX.</b> Measure rotating of gearbox. <Ref. to PS-40, TURNING RESISTANCE OF GEARBOX, INSPECTION, Steering Gearbox.>	Is the measured rotating resistance the same as the following values: 11.18 N (1.14 kgf, 2.51 lb) or less at straight position / 15.79 N (1.61 kgf, 3.55 lb) or less at any other positions within 20% difference between clockwise and counterclockwise?	Go to step 11.	Readjust backlash, and if ineffective, replace bad parts.
<b>11 CHECK GEARBOX.</b> Measure sliding of gearbox. <Ref. to PS-39, SERVICE LIMIT, INSPECTION, Steering Gearbox.>	Is the measured sliding resistance within the following value: 304 N (31 kgf, 68 lb) or less within 20% difference between left and right directions?	Steering effort is normal.	Readjust backlash, and if ineffective, replace bad parts.

# GENERAL DIAGNOSTIC TABLE

POWER ASSISTED SYSTEM (POWER STEERING)

---

**MEMO:**