

REAR SUSPENSION

RS

	Page
1. General Description	2
2. Wheel Alignment	8
3. Rear Stabilizer	9
4. Rear Arm	10
5. Link Upper	14
6. Rear Shock Absorber	16
7. Link Front	18
8. Link Rear	19
9. Support Sub Frame Front	21
10. Rear Sub Frame	22
11. Helper	23
12. General Diagnostic Table	24

1. General Description

A: SPECIFICATIONS

Refer to “General Description” of FS section about value of wheel alignment. <Ref. to FS-2, General Description.>

NOTE:

- Front and rear toe-in and front camber can be adjusted. If toe-in or camber tolerance exceeds specifications, adjust toe-in and camber to the adjustment standard value.
- The other items indicated in the specification table cannot be adjusted. If the other items exceed specifications, check suspension parts and connections for deformities; replace with new ones as required.

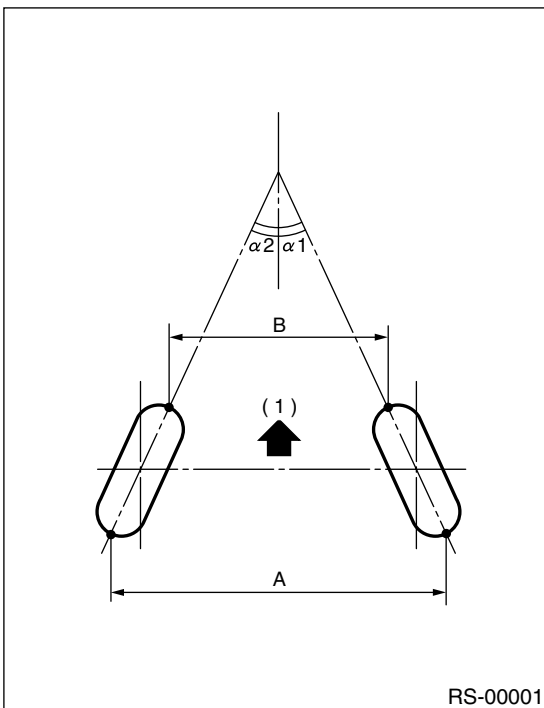

(1) Front

$A - B =$ Positive: Toe-in, Negative: Toe-out

$\alpha 1, \alpha 2:$ Each toe-in angle

B: COMPONENT

1. REAR SUSPENSION

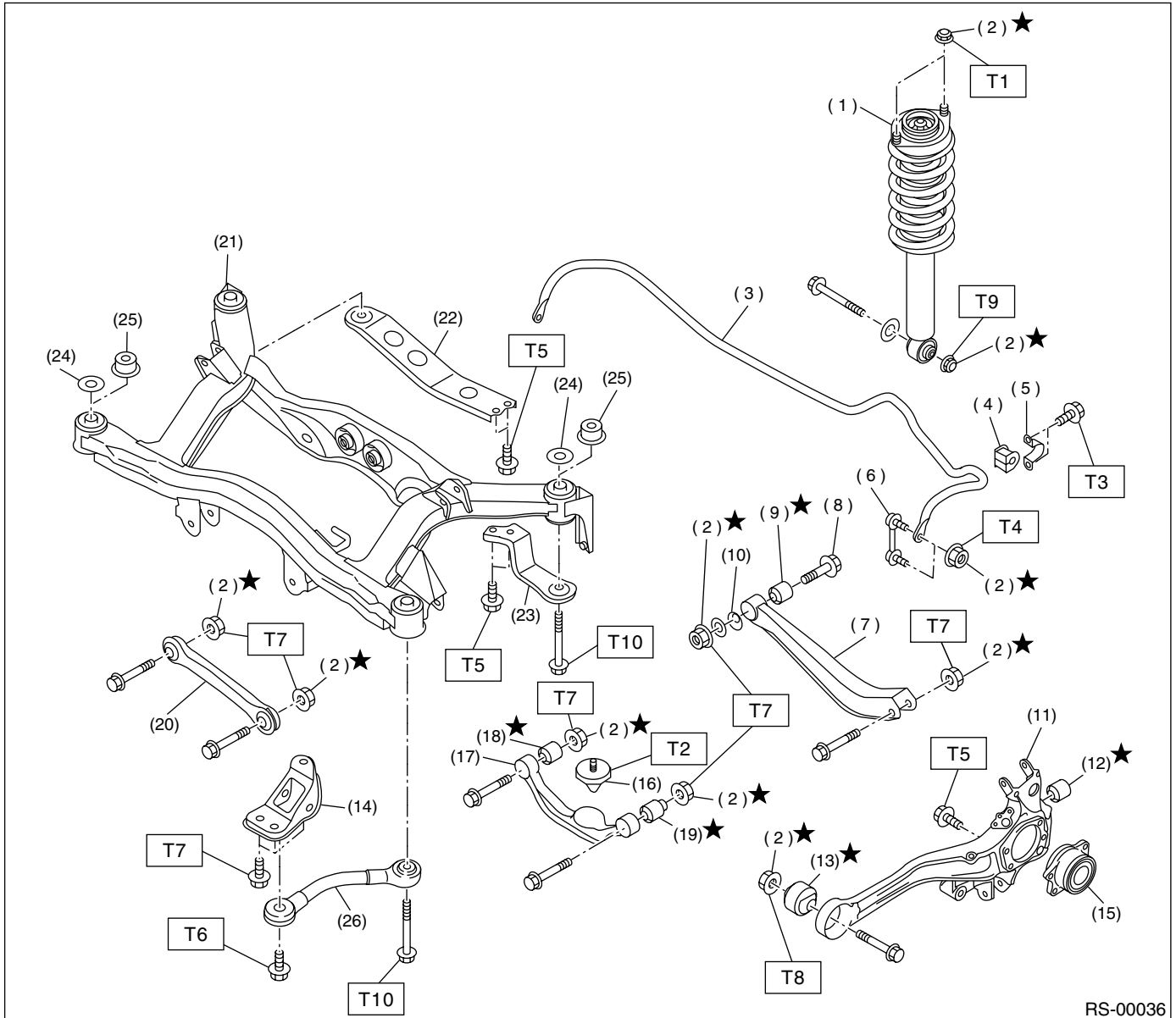

RS-00036

- | | |
|-----------------------------|---|
| (1) Shock absorber | (15) Hub bearing unit |
| (2) Self-locking nut | (16) Helper |
| (3) Stabilizer | (17) Link upper |
| (4) Stabilizer bushing | (18) Link upper bushing (Inside) |
| (5) Clamp | (19) Link upper bushing (Outside) |
| (6) Stabilizer link | (20) Link front |
| (7) Link rear | (21) Rear sub frame |
| (8) Adjusting bolt | (22) Support sub frame (RH) |
| (9) Link rear bushing | (23) Support sub frame (LH) |
| (10) Adjusting washer | (24) Stopper upper (Except OUTBACK model) |
| (11) Rear arm | (25) Stopper upper (OUTBACK MODEL) |
| (12) Rear arm rear bushing | (26) Support sub frame front |
| (13) Rear arm front bushing | |
| (14) Rear arm bracket | |

Tightening torque: N-m (kgf-m, ft-lb)

- | | |
|-------------|------------------------|
| T1: | 30 (3.1, 22.4) |
| T2: | 32 (3.3, 24) |
| T3: | 40 (4.1, 30) |
| T4: | 44 (4.5, 32.5) |
| T5: | 65 (6.6, 48) |
| T6: | 80 (8.2, 59) |
| T7: | 120 (12.2, 88) |
| T8: | 150 (15.3, 111) |
| T9: | 160 (16.3, 118) |
| T10: | 175 (17.8, 129) |

GENERAL DESCRIPTION

REAR SUSPENSION

2. SHOCK ABSORBER

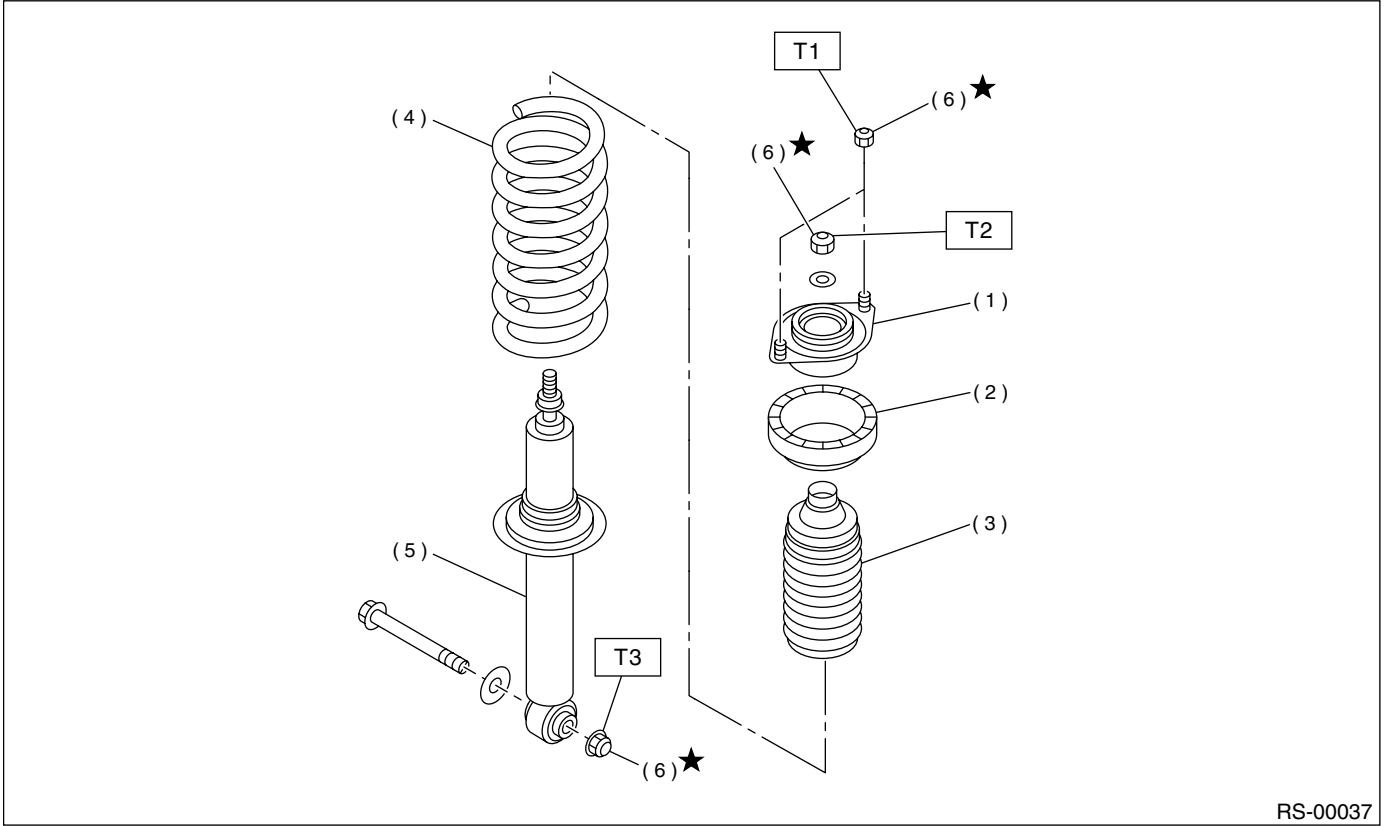

- (1) Mount
- (2) Rubber seat upper
- (3) Dust cover
- (4) Coil spring
- (5) Shock absorber
- (6) Self-locking nut

Tightening torque: N·m (kgf·m, ft·lb)

T1: 30 (3.1, 22.4)

T2: 35 (3.6, 26)

T3: 160 (16.3, 118)

C: CAUTION

- Wear working clothing, including a cap, protective goggles, and protective shoes during operation.
- Remove contamination including dirt and corrosion before removal, installation or disassembly.
- Keep the disassembled parts in order and protect them from dust or dirt.
- Before removal, installation or disassembly, be sure to clarify the failure. Avoid unnecessary removal, installation, disassembly, and replacement.
- Use SUBARU genuine grease etc. or the equivalent. Do not mix grease etc. with that of another grade or from other manufacturers.
- Be sure to tighten fasteners including bolts and nuts to the specified torque.
- Place shop jacks or safety stands at the specified points.
- Apply grease onto sliding or revolution surfaces before installation.
- Before installing O-rings or snap rings, apply sufficient amount of grease to avoid damage and deformation.
- Before securing a part on a vise, place cushioning material such as wood blocks, aluminum plate, or shop cloth between the part and the vise.
- Before disposing shock absorbers, be sure to bleed gas completely. Also, do not throw away in fire.

D: PREPARATION TOOL

1. SPECIAL TOOLS

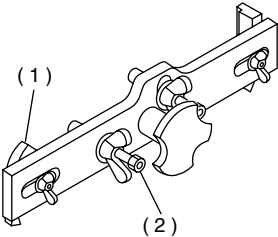
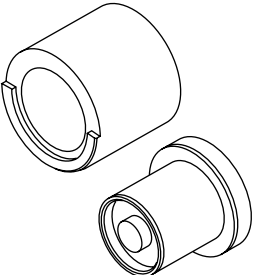
ILLUSTRATION	TOOL NUMBER	DESCRIPTION	REMARKS
 <p style="text-align: center;">ST-927380002</p>	927380002	ADAPTER	Used as an adapter for camber & caster gauge when measuring camber and caster. (1) 28199AC000 PLATE (2) 28199AC010 BOLT
 <p style="text-align: center;">ST20099AE000</p>	20099AE000	INSTALLER & REMOVER	Used for replacing link rear bushing.

GENERAL DESCRIPTION

REAR SUSPENSION

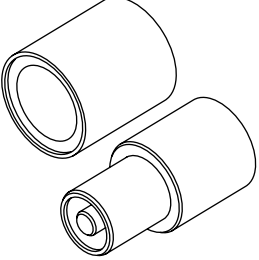
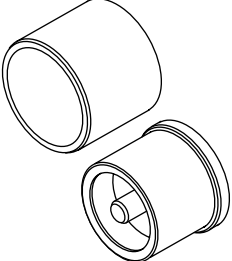
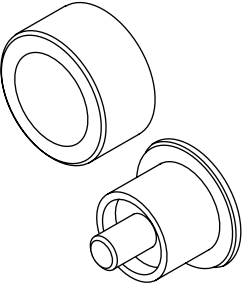
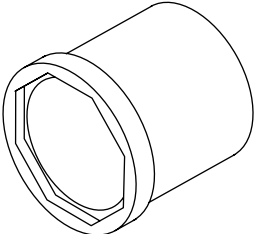
ILLUSTRATION	TOOL NUMBER	DESCRIPTION	REMARKS
 <p style="text-align: center;">ST20099AE010</p>	20099AE010	INSTALLER & REMOVER	Used for replacing link upper bushing.
 <p style="text-align: center;">ST20099AE020</p>	20099AE020	INSTALLER & REMOVER SET	Used for replacing rear arm front bushing.
 <p style="text-align: center;">ST20099AE040</p>	20099AE040	INSTALLER & REMOVER SET	Used for replacing rear arm rear bushing.
 <p style="text-align: center;">ST20099AE030</p>	20099AE030	HELPER SOCKET WRENCH	Used for replacing helper.

GENERAL DESCRIPTION

REAR SUSPENSION

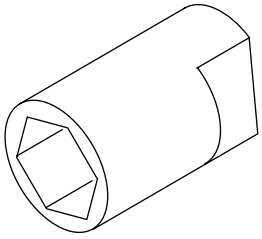
ILLUSTRATION	TOOL NUMBER	DESCRIPTION	REMARKS
 ST-927760000	927760000	STRUT MOUNT SOCKET	Used for disassembling and assembling strut and shock mount.

2. GENERAL PURPOSE TOOLS

TOOL NAME	REMARKS
Alignment gauge	Used for wheel alignment measurement.
Turning radius gauge	Used for wheel alignment measurement.
Toe-in gauge	Used for toe-in measurement.
Transmission jack	Used for suspension assembly/disassembly.
Bearing puller	Used for removing bushings.

2. Wheel Alignment

A: INSPECTION

NOTE:

The front and rear wheel alignment must be measured and/or adjusted at once to obtain accuracy. Measure and/or adjust the rear wheel alignment together with the front.

Follow the procedure in "FS" section "Wheel Alignment" for measurement and/or adjustment of wheel alignment. <Ref. to FS-6, Wheel Alignment.>

3. Rear Stabilizer

A: REMOVAL

- 1) Jack-up the rear part of the vehicle, support it with safety stands (rigid racks).
- 2) Remove bolts which secure stabilizer link to rear arm.

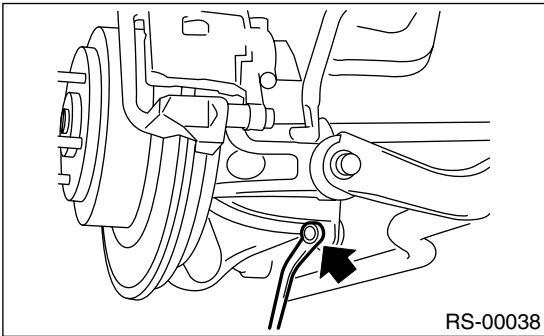

- 3) Remove bolts which secure stabilizer to sub frame.

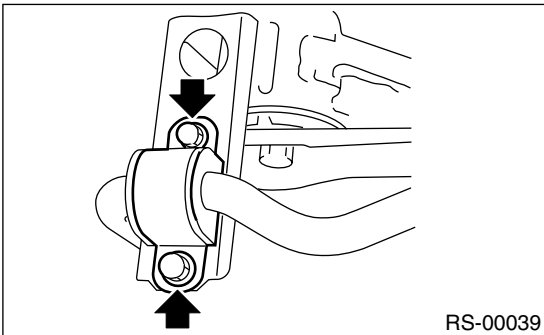

B: INSTALLATION

Install in the reverse order of removal.

NOTE:

Ensure that bushing and stabilizer have the same identification colors when installing.

CAUTION:

Use a new self-locking nut.

Tightening torque:

Stabilizer link to rear arm

44 N·m (4.5 kgf-m, 32.5 ft-lb)

Clamp to sub frame

40 N·m (4.1 kgf-m, 30 ft-lb)

C: INSPECTION

- 1) Check bushing for cracks, fatigue or damage.
- 2) Check stabilizer links for deformities, cracks, or damage, and bushing for protrusions from the hole of stabilizer link.

REAR ARM

REAR SUSPENSION

4. Rear Arm

A: REMOVAL

- 1) Lift-up the vehicle and remove rear wheel.
- 2) Remove support sub frame front.
<Ref. to RS-21, REMOVAL, Support Sub Frame Front.>
- 3) Remove bearing unit.
<Ref. to DS-24, REMOVAL, Hub Unit Bearing.>
- 4) Remove bolt securing parking brake cable clamp to rear arm.

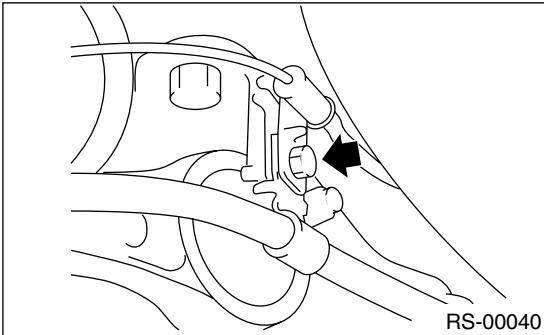

- 5) Remove bolt securing brake hose to rear arm.

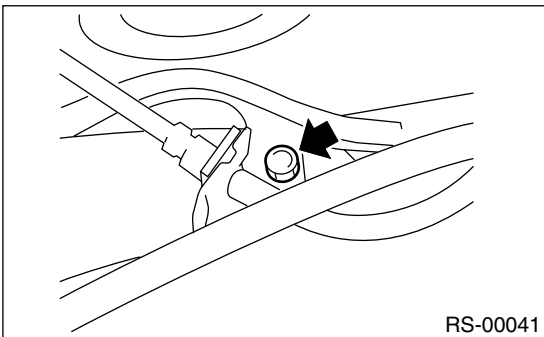

- 6) Remove bolt securing ABS sensor to rear arm.

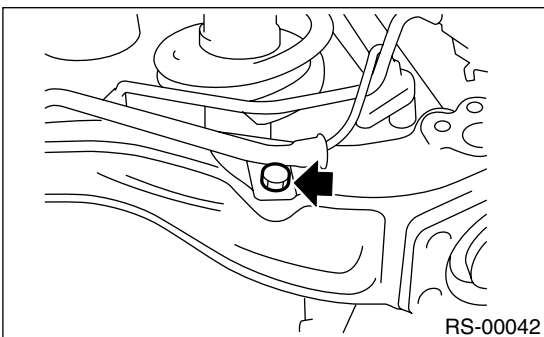

- 7) Suspend the back plate from sub frame.

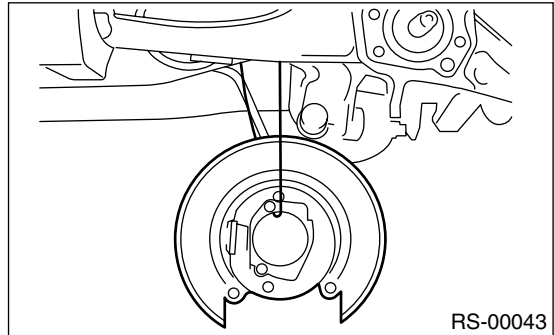

- 8) Remove nut securing stabilizer link to rear arm.

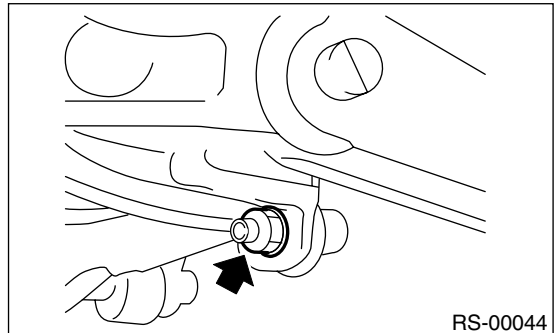

- 9) Remove bolt securing shock absorber to rear arm.

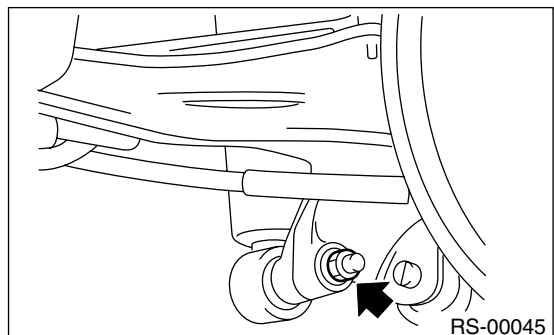

- 10) Use transmission jack to support rear arm horizontally.

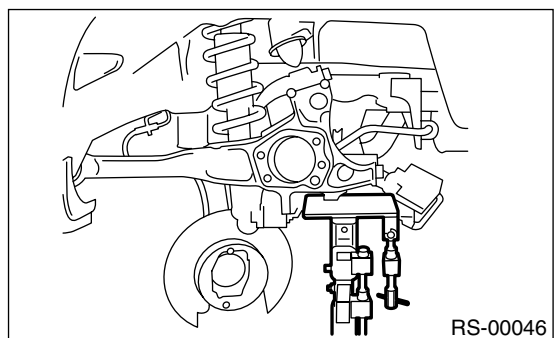

11) Remove bolt securing rear arm to body.

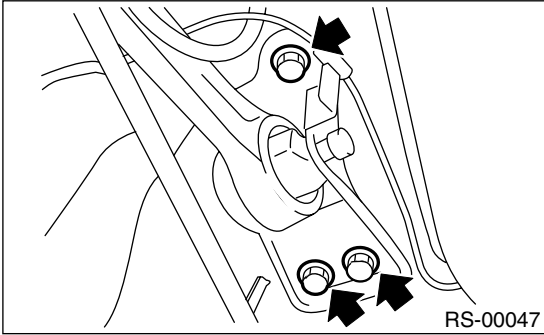

12) Loosen nut securing link front to rear arm.

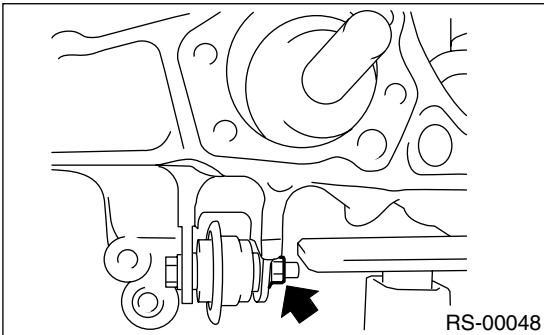

13) Loosen nut securing link rear to rear arm.

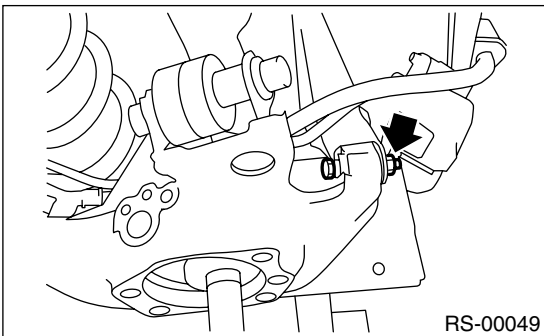

14) Loosen nut securing link upper to rear arm.

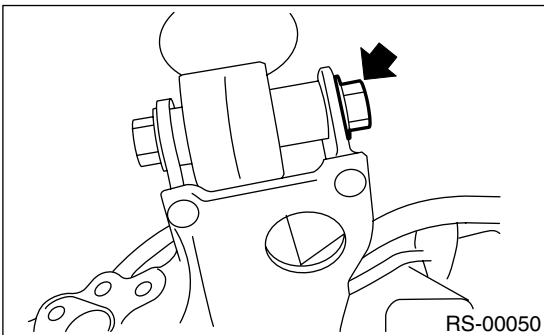

15) Remove bolts securing rear arm to links and remove rear arm.

B: INSTALLATION

CAUTION:

Use a new self-locking nut.

1) Use a transmission jack to support the rear arm.
2) Install rear arm and temporarily tighten bolts securing rear arm to links.

3) Install bearing unit.

<Ref. to DS-25, INSTALLATION, Hub Unit Bearing.>

4) Install bolt securing ABS sensor to rear arm.

5) Install bolt securing brake hose to rear arm.

6) Install bolt securing parking brake cable clamp to rear arm.

7) Place jack (furnished with vehicle) upside down and position it between link rear and sub frame. Adjust jack position so rear shock absorber is aligned with rear arm at their corresponding holes. Install lower shock absorber bolts.

CAUTION:

Put a cloth between jack and its mating area to protect link rear and sub frame from scratches.

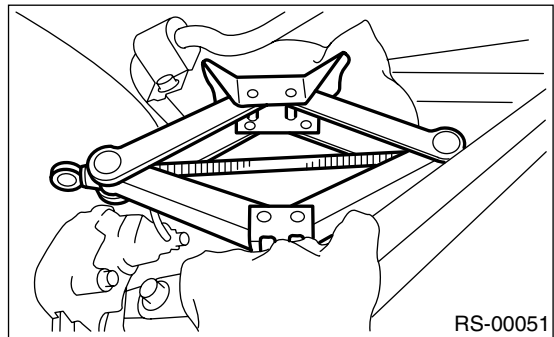

8) Using transmission jack, support rear arm horizontally and tighten nuts and bolts securing rear arm, link front, link rear, link upper and shock absorber.

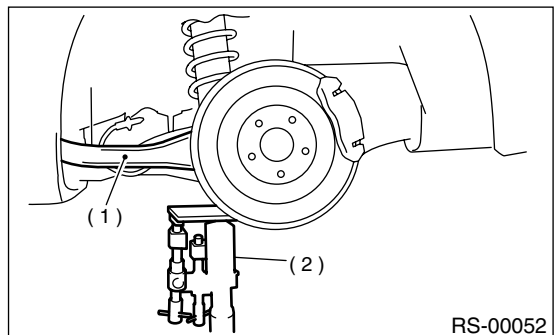

(1) Rear arm

(2) Transmission jack

REAR ARM

REAR SUSPENSION

9) Install support sub frame front.

NOTE:

Check wheel alignment and adjust if necessary.

Tightening torque:

Refer to COMPONENT of General Description for tightening torque. <Ref. to RS-3, REAR SUSPENSION, COMPONENT, General Description.>

C: DISASSEMBLY

1. FRONT BUSHING

1) Using ST-A, B, press front bushing out of place.
ST-A, B 20099AE020INSTALLER & REMOVER SET

- (1) Set ST-A in position with larger inside diameter side facing up.
- (2) Set rear arm with protruded bushing side facing down.
- (3) Place ST-B on upper side of bushing, then press bushing out of position.

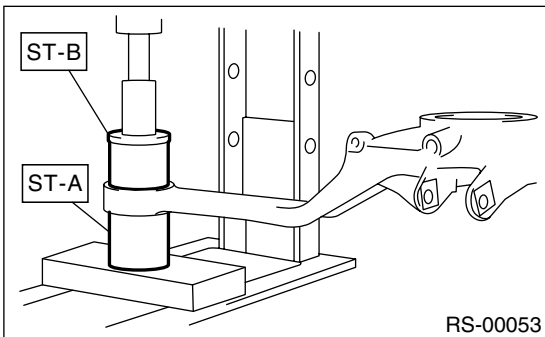

2. REAR BUSHING

Using ST-C and bearing puller, press rear bushing out of place.

ST-C 20099AE040INSTALLER & REMOVER SET

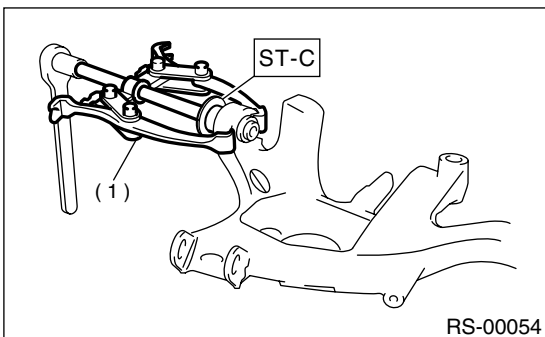

(1) Bearing puller

D: ASSEMBLY

1. FRONT BUSHING

1) Using ST-A, B, press bushing into rear arm.
ST-A, B 20099AE020INSTALLER & REMOVER SET

- (1) Set ST-A in position with smaller inside diameter side facing up.
- (2) Set rear arm in position with outer side of vehicle body facing down.
- (3) Place bushing on upper side of rear arm.
- (4) Place ST-B on upper side of bushing, then press bushing into position.

CAUTION:

- Install bushing with painted side facing up.
- Install front bushing in the proper direction, as shown in figure.

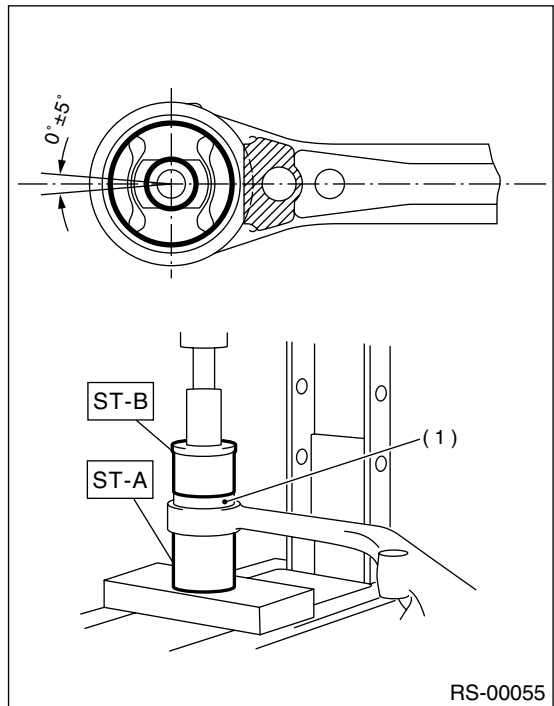

(1) Bushing

2. REAR BUSHING

1) Using ST-C, D and bearing puller, press bushing into rear arm.

ST-C, D 20099AE040INSTALLER & REMOVER SET

- (1) Insert bushing into bore in ST-D.
- (2) Set ST-C, ST-D and bearing puller in position, as shown in the figure, and press bushing into position.

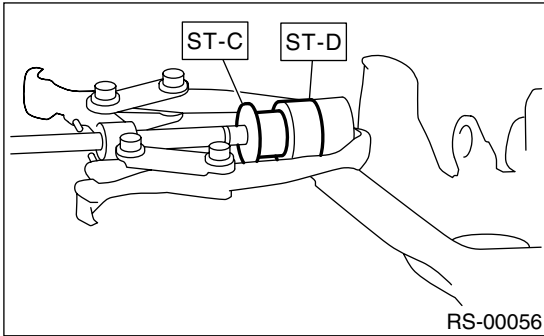

E: INSPECTION

Check rear arm for bends, corrosion or damage.

LINK UPPER

REAR SUSPENSION

5. Link Upper

A: REMOVAL

- 1) Loosen wheel nuts. Lift-up vehicle and remove wheel.
- 2) Use transmission jack to support rear arm horizontally.

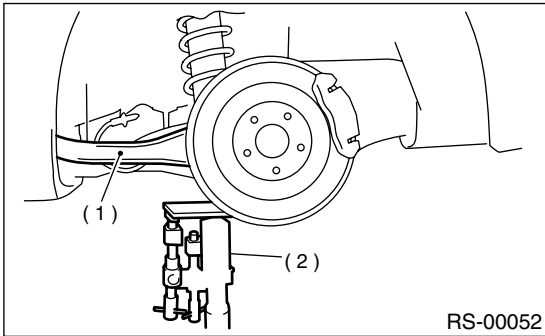

- (1) Rear arm
- (2) Transmission jack

- 3) Remove bolt securing link upper to sub frame.

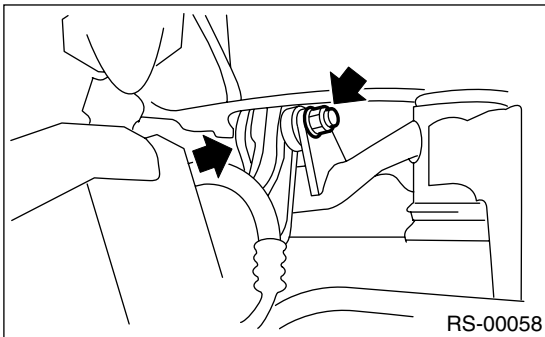

- 4) Remove bolts which secure link upper to rear arm and detach link upper.

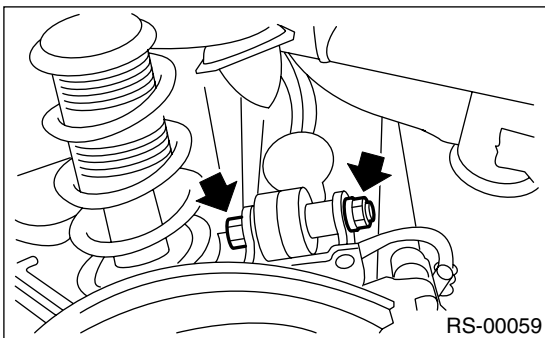

B: INSTALLATION

Install in the reverse order of removal, observing the following instructions.

CAUTION:

Using transmission jack, support rear arm horizontally, install link upper and tighten nuts to specified torque.

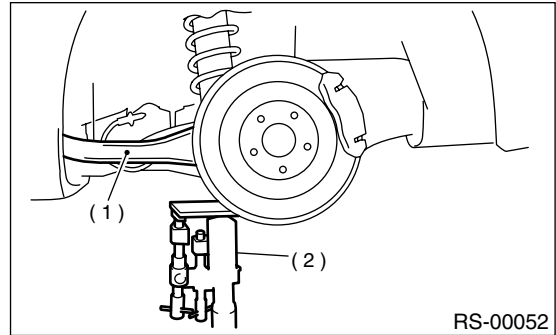

- (1) Rear arm
- (2) Transmission jack

CAUTION:

- Tighten nut when installing adjusting bolt.
- Use a new self-locking nut.

NOTE:

Check wheel alignment and adjust if necessary.

Tightening torque:

120 N·m (12.2 kgf-m, 88 ft-lb)

C: DISASSEMBLY

Using ST, press bushing out of place.

ST 20099AE010 INSTALLER & REMOVER

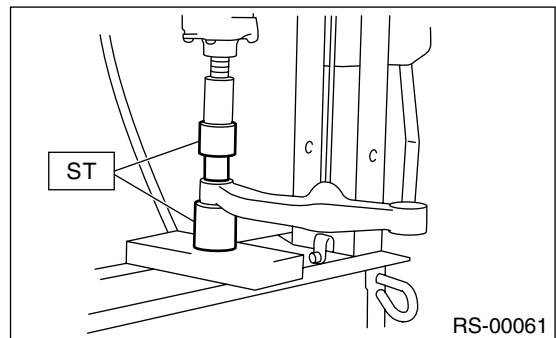

D: ASSEMBLY

1) Using ST, press bushing into place.

ST 20099AE010 INSTALLER & REMOVER

CAUTION:

Outer bushing has a “directional” design. Be sure to install bushing with longer inner housing side facing vehicle rear.

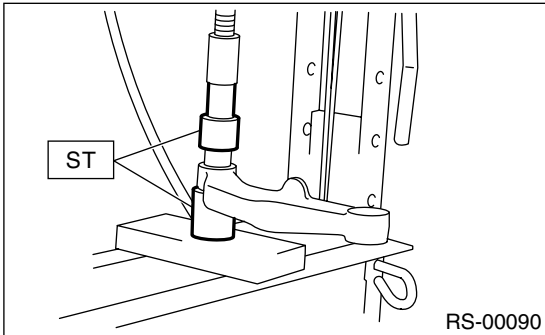

E: INSPECTION

Visually check link upper for damage or bends.

REAR SHOCK ABSORBER

REAR SUSPENSION

6. Rear Shock Absorber

A: REMOVAL

- 1) Lift-up vehicle and remove rear wheels.
- 2) Remove clip and detach floor mat. (Wagon model)

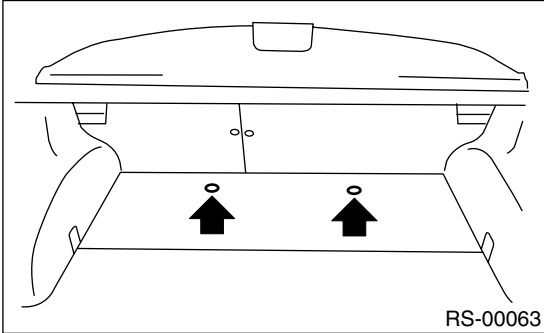

- 3) Detach trunk mat. (Sedan model)
- 4) Roll up the trunk side trim. (Sedan model)

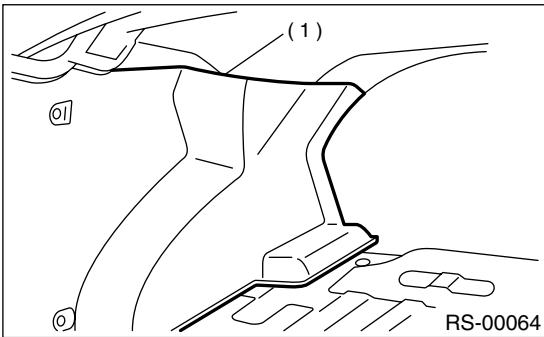

(1) Trunk side trim

- 5) Remove bolt securing shock absorber to rear arm.

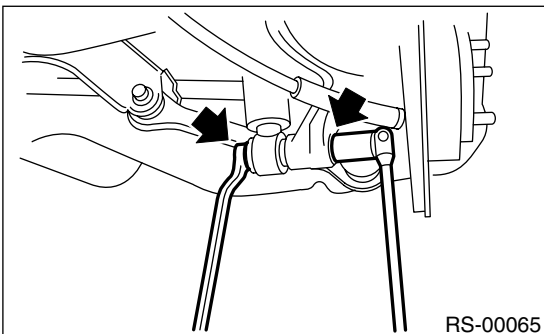

- 6) Use a jack to support the shock absorber.
- 7) Remove nuts securing shock absorber mount to body.

• Wagon

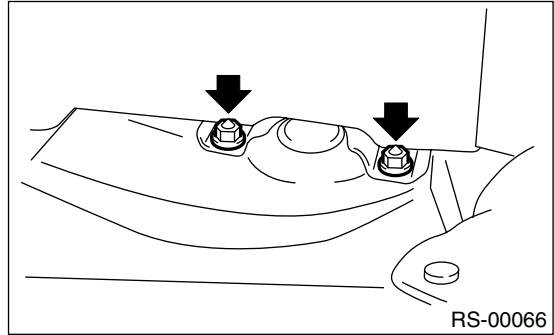

• Sedan

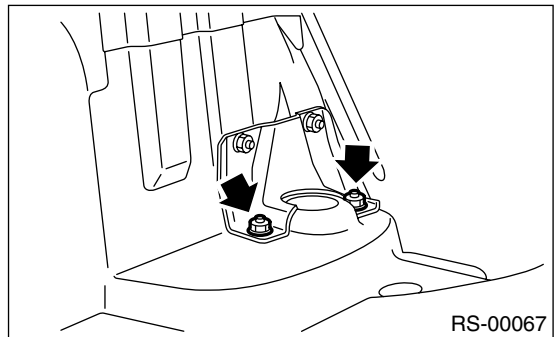

- 8) Remove shock absorber.

B: INSTALLATION

- 1) Use a jack to support the shock absorber.
- 2) Tighten self-locking nut used to secure shock absorber to vehicle body.

CAUTION:

Use a new self-locking nut.

Tightening torque:

30 N·m (3.1 kgf-m, 22 ft-lb)

- 3) Place jack (furnished with vehicle) upside down and position it between link rear and sub frame. Adjust jack position so rear shock absorber is aligned with rear arm at their corresponding holes. Install lower shock absorber bolts.

CAUTION:

Put a cloth between jack and its mating area to protect link rear and sub frame from scratches.

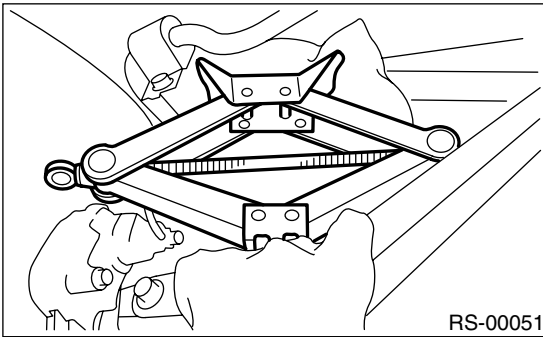

- 4) Using transmission jack, support rear arm horizontally and tighten shock absorber nuts and bolts to specified torque.

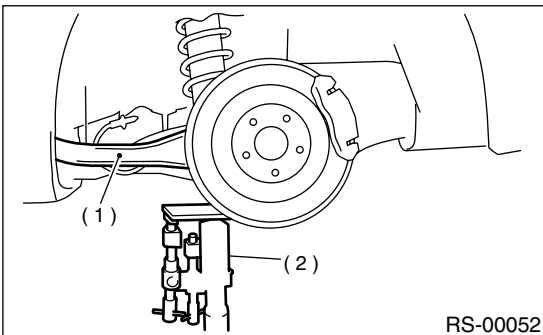

- (1) Rear arm
- (2) Transmission jack

Tightening torque:

160 N·m (16.3 kgf-m, 118 ft-lb)

CAUTION:

Use a new self-locking nut.

- 5) Install floor mat. (Wagon model)
- 6) Set trunk side trim. (Sedan model)

- 7) Install trunk mat. (Sedan model)

NOTE:

Check wheel alignment and adjust if necessary.

C: DISASSEMBLY

For disassembly of shock absorber, refer to procedures outlined under front strut as a guide.
<Ref. to FS-19, DISASSEMBLY, Front Strut.>

D: ASSEMBLY

Refer to Front Strut as a guide for assembly procedures.
<Ref. to FS-19, ASSEMBLY, Front Strut.>

E: INSPECTION

Refer to Front Strut as a guide for inspection procedures.
<Ref. to FS-20, INSPECTION, Front Strut.>

F: DISPOSAL

CAUTION:

- Before handling shock absorber, be sure to wear goggles to protect eyes from gas, oil and/or filings.
- Completely discharge the gas from the shock absorber before disposal. Follow the disposal procedure outlined below.
- Do not disassemble shock absorber or place into a fire.
- Drill holes before disposing of shock absorber.

- 1) Place shock absorber on a flat and level surface with piston rod fully extended.
- 2) Using a 2 to 3 mm (0.08 to 0.12 in) dia. drill, drill 30 mm (1.18 in) deep holes in areas shown in the figure.

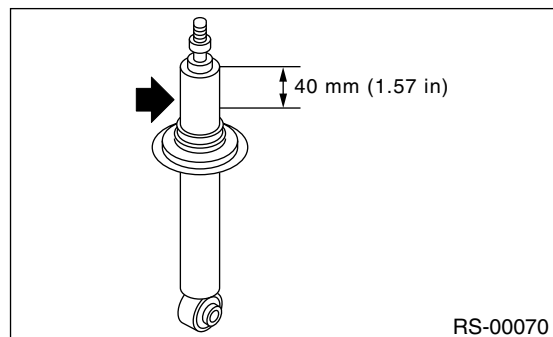

LINK FRONT

REAR SUSPENSION

7. Link Front

A: REMOVAL

- 1) Loosen wheel nuts. Lift-up vehicle and remove wheel.
- 2) Use transmission jack to support rear arm horizontally.

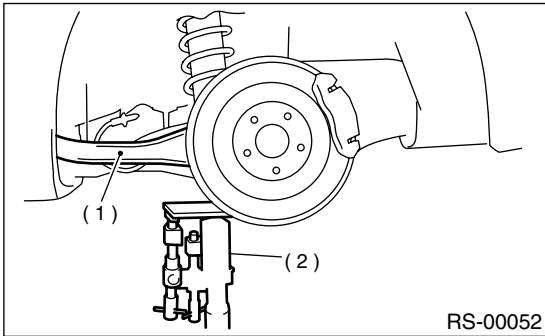

- (1) Rear arm
- (2) Transmission jack

- 3) Remove bolt securing link front to sub frame.

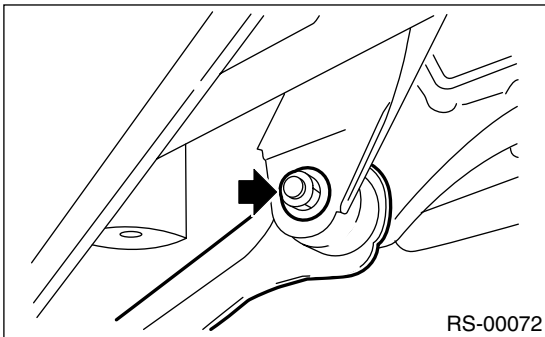

- 4) Remove bolts which secure link front to rear arm and detach link front.

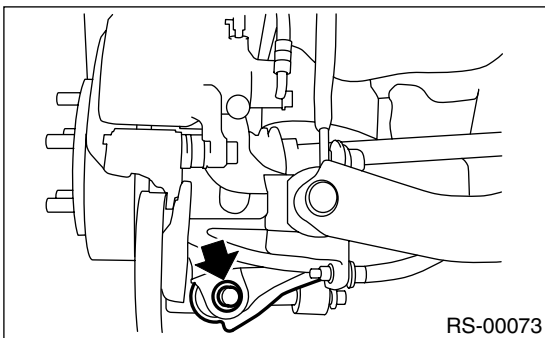

NOTE:

Link front bushing cannot be replaced alone. Always replace link front and bushing as a single unit.

B: INSTALLATION

Install in the reverse order of removal, observing the following instructions.

CAUTION:

- Using transmission jack, support rear arm horizontally, install link front and tighten nuts to specified torque.

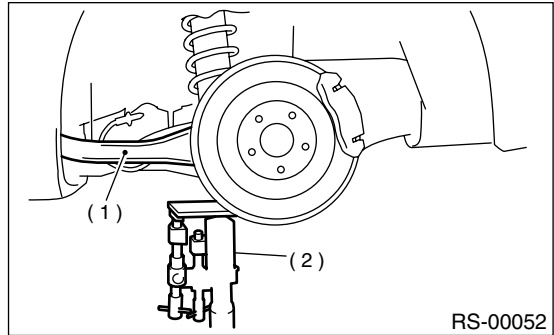

- (1) Rear arm
- (2) Transmission jack

- Install link front with protruded side facing front.

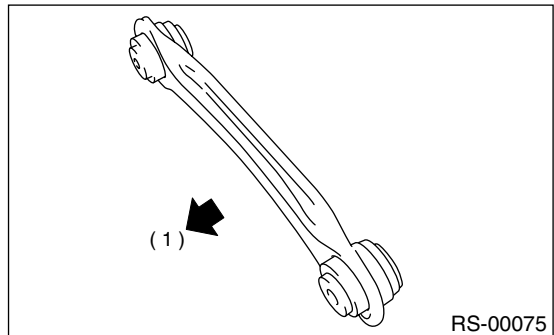

- (1) Front

CAUTION:

Use a new self-locking nut.

NOTE:

Check wheel alignment and adjust if necessary.

Tightening torque:

120 N·m (12.2 kgf·m, 88 ft·lb)

C: INSPECTION

Visually check link front for damage or bends.

8. Link Rear

A: REMOVAL

- 1) Loosen wheel nuts. Lift-up vehicle and remove wheel.
- 2) Remove bolt securing stabilizer clamps to sub frame.

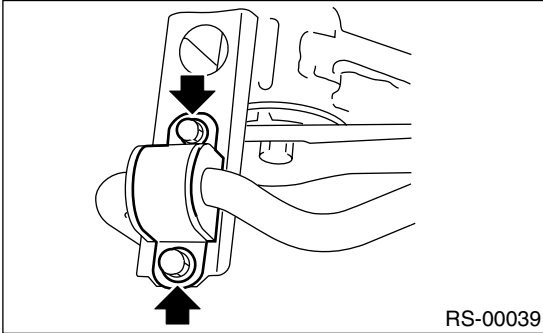

- 3) Remove support sub frame RH. (When removing RH side link rear.)

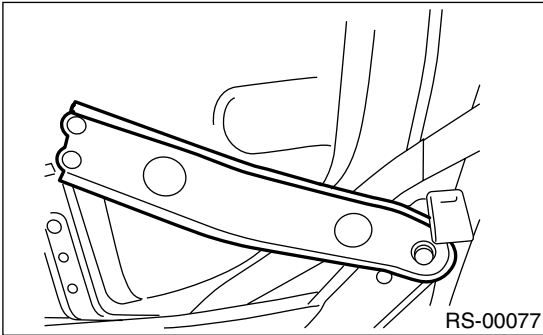

- 4) Remove stabilizer link.

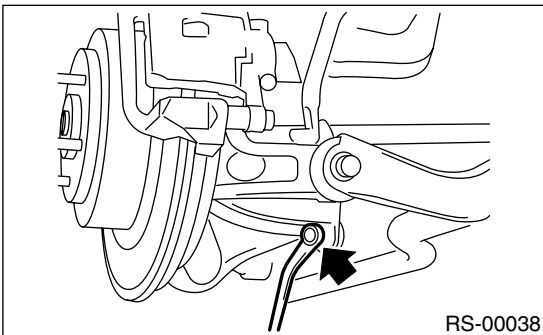

- 5) Use transmission jack to support rear arm horizontally.

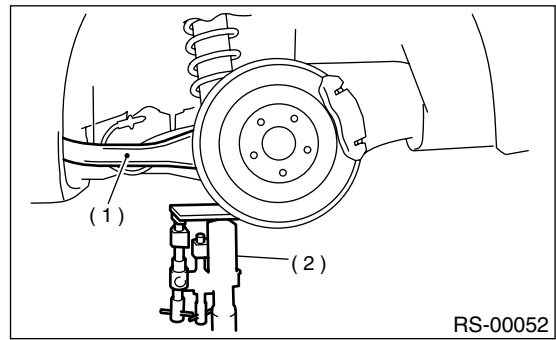

- (1) Rear arm
- (2) Transmission jack

- 6) Remove bolt securing link rear to rear arm.

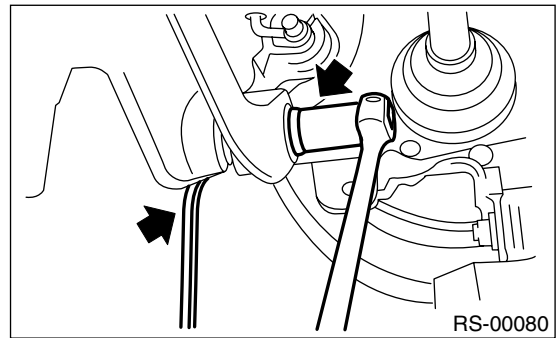

- 7) Scribe an alignment mark on link rear adjusting bolt and sub frame.

- 8) Remove bolts securing link rear to sub frame, detach link rear.

CAUTION:

To loosen adjusting bolt, always loosen nut while holding the head of adjusting bolt.

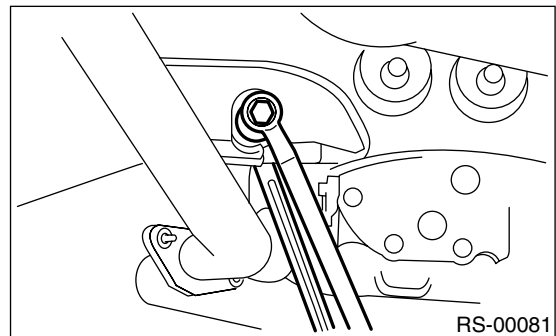

LINK REAR

REAR SUSPENSION

B: INSTALLATION

Install in the reverse order of removal, observing the following instructions.

CAUTION:

Using transmission jack, support rear arm horizontally, install link rear and tighten nuts to specified torque.

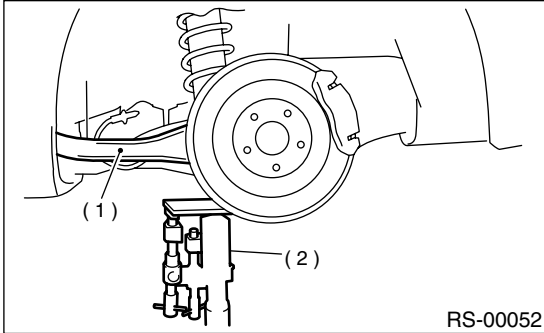

- (1) Rear arm
- (2) Transmission jack

CAUTION:

- Tighten nut when installing adjusting bolt.
- Use a new self-locking nut.

NOTE:

Check wheel alignment and adjust if necessary.

C: DISASSEMBLY

Using ST-A, B, press bushing out of place.
ST-A, B 20099AE000INSTALLER & REMOVER

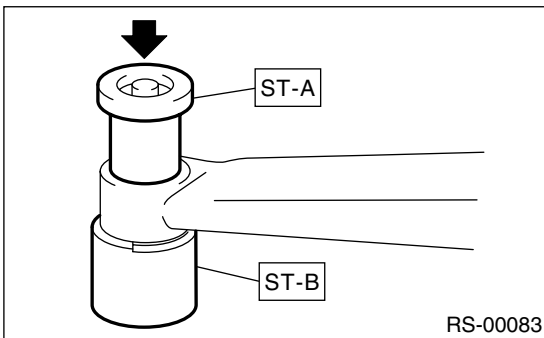

D: ASSEMBLY

Using ST-A and ST-B, press bushing into place.
ST-A, B 20099AE000INSTALLER & REMOVER

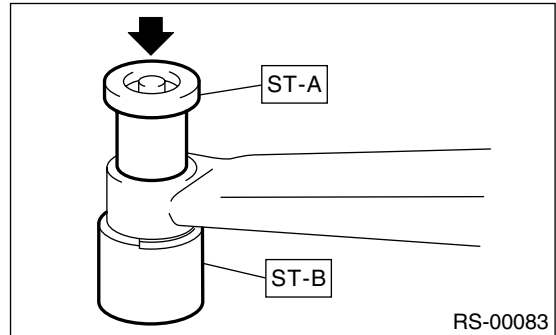

E: INSPECTION

Visually check link rear for damage or bends.

9. Support Sub Frame Front

A: REMOVAL

- 1) Lift-up the vehicle, using support stand to support rear sub frame.
- 2) Remove support sub frame front.

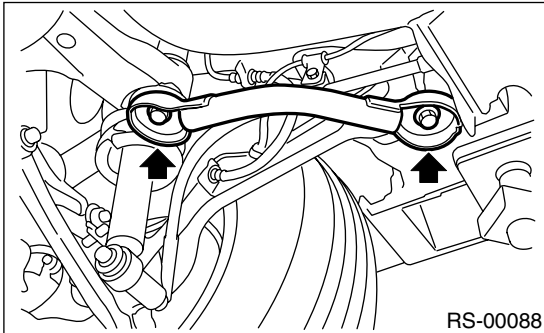

B: INSTALLATION

- 1) Install in reverse order of removal.

Tightening torque:

Support sub frame front to rear arm bracket

80 N·m (8.2 kgf-m, 59 ft-lb)

Support sub frame front to rear sub frame

175 N·m (17.8 kgf-m, 129 ft-lb)

C: INSPECTION

Visually check support sub frame front for damage or bends.

REAR SUB FRAME

REAR SUSPENSION

10. Rear Sub Frame

A: REMOVAL

1) Separate front exhaust pipe and rear exhaust pipe.

2) Remove rear exhaust pipe and muffler.

3) Remove rear differential.

With T-type

<Ref. to DI-25, REMOVAL, Rear Differential for T-type.>

With VA-type

<Ref. to DI-42, REMOVAL, Rear Differential for VA-type.>

4) Disconnect link front from sub frame.

<Ref. to RS-18, REMOVAL, Link Front.>

5) Disconnect link rear from sub frame.

<Ref. to RS-19, REMOVAL, Link Rear.>

6) Disconnect link upper from sub frame.

<Ref. to RS-14, REMOVAL, Link Upper.>

7) Place transmission jack under sub frame.

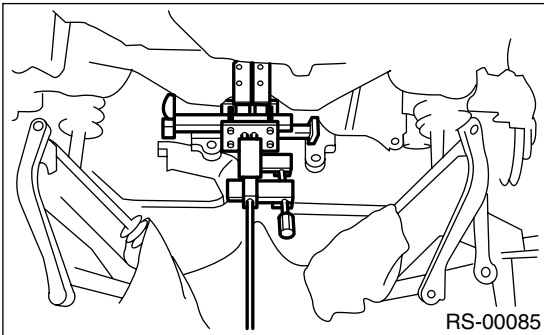

8) Remove support sub frame front.

9) After removing bolts, remove sub frame and support sub frame from vehicle body.

B: INSTALLATION

1) Install in reverse order of removal.

2) For installation and tightening torque of rear differential.

With T-type

<Ref. to DI-26, INSTALLATION, Rear Differential for T-type.>

With VA-type

<Ref. to DI-43, INSTALLATION, Rear Differential for VA-type.>

3) Using transmission jack, support rear arm horizontally and tighten nuts and bolts securing rear arm, link front, link rear, link upper and shock absorber.

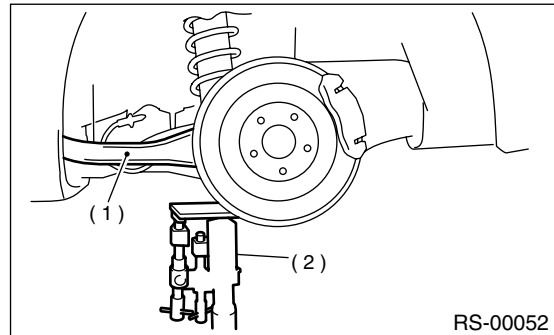

(1) Rear arm

(2) Transmission jack

4) Install support sub frame front.

NOTE:

Check wheel alignment and adjust if necessary.

C: INSPECTION

Check removed parts for wear, damage and cracks, and correct or replace if defective.

11.Helper

A: REMOVAL

1) Jack-up the rear part of the vehicle, support it with safety stands (rigid racks).

2) Using ST, remove helper.

ST 20099AE030 HELPER SOCKET WRENCH

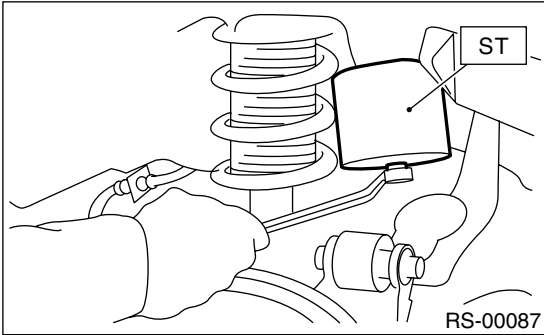

B: INSTALLATION

Install in the reverse order of removal.

Tightening torque:

32 N·m (3.3 kgf-m, 24 ft-lb)

C: INSPECTION

Check helper for cracks, fatigue or damage.

GENERAL DIAGNOSTIC TABLE

REAR SUSPENSION

12. General Diagnostic Table

A: INSPECTION

1. IMPROPER VEHICLE POSTURE OR IMPROPER WHEEL ARCH HEIGHT

Possible causes	Countermeasures
(1) Permanent distortion or breakage of coil spring	Replace.
(2) Unsmooth operation of damper strut and/or shock absorber	Replace.
(3) Installation of wrong strut and/or shock absorber	Replace with proper parts.
(4) Installation of wrong coil spring	Replace with proper parts.

2. POOR RIDE COMFORT

- 1) Large rebound shock
- 2) Rocking of vehicle continues too long after running over bump and/or hump.
- 3) Large shock in bumping

Possible causes	Countermeasures
(1) Breakage of coil spring	Replace.
(2) Overinflation pressure of tire	Adjust.
(3) Improper wheel arch height	Adjust or replace coil springs with new ones.
(4) Fault in operation of damper strut and/or shock absorber	Replace.
(5) Damage or deformation of strut mount and/or shock absorber mount	Replace.
(6) Unsuitability of maximum and/or minimum length of damper strut and/or shock absorber	Replace with proper parts.
(7) Deformation or loss of bushing	Replace.
(8) Deformation or damage of helper in strut assembly and/or shock absorber	Replace.
(9) Oil leakage of damper strut and/or shock absorber	Replace.

3. NOISE

Possible causes	Countermeasures
(1) Wear or damage of damper strut and/or shock absorber component parts	Replace.
(2) Loosening of suspension link installing bolt	Retighten to the specified torque.
(3) Deformation or loss of bushing	Replace.
(4) Unsuitability of maximum and/or minimum length of damper strut and/or shock absorber	Replace with proper parts.
(5) Breakage of coil spring	Replace.
(6) Wear or damage of ball joint	Replace.
(7) Deformation of stabilizer clamp	Replace.