

GLASS/WINDOWS/MIRRORS

GW

	Page
1. General Description	2
2. Power Window System	8
3. Rear Window Defogger System	9
4. Windshield Wiper Deicer System	10
5. Remote Control Mirror System	11
6. Front Door Glass	12
7. Front Regulator and Motor Assembly	16
8. Rear Door Glass	17
9. Rear Regulator and Motor Assembly	19
10. Windshield Glass	20
11. Rear Gate Glass	23
12. Rear Quarter Glass	24
13. Rear Window Glass	26
14. Roof Window Glass	27
15. Inner Rearview Mirror	28
16. Power Window Control Switch	29
17. Rear Window Defogger Switch	31
18. Rear Window Defogger	32
19. Outer Mirror Assembly	33
20. Outer Mirror	34
21. Remote Control Mirror Switch	35
22. Wiper Deicer	36
23. Wiper Deicer Switch	37

GENERAL DESCRIPTION

GLASS/WINDOWS/MIRRORS

1. General Description

A: COMPONENT

1. FIXED GLASS (SEDAN)

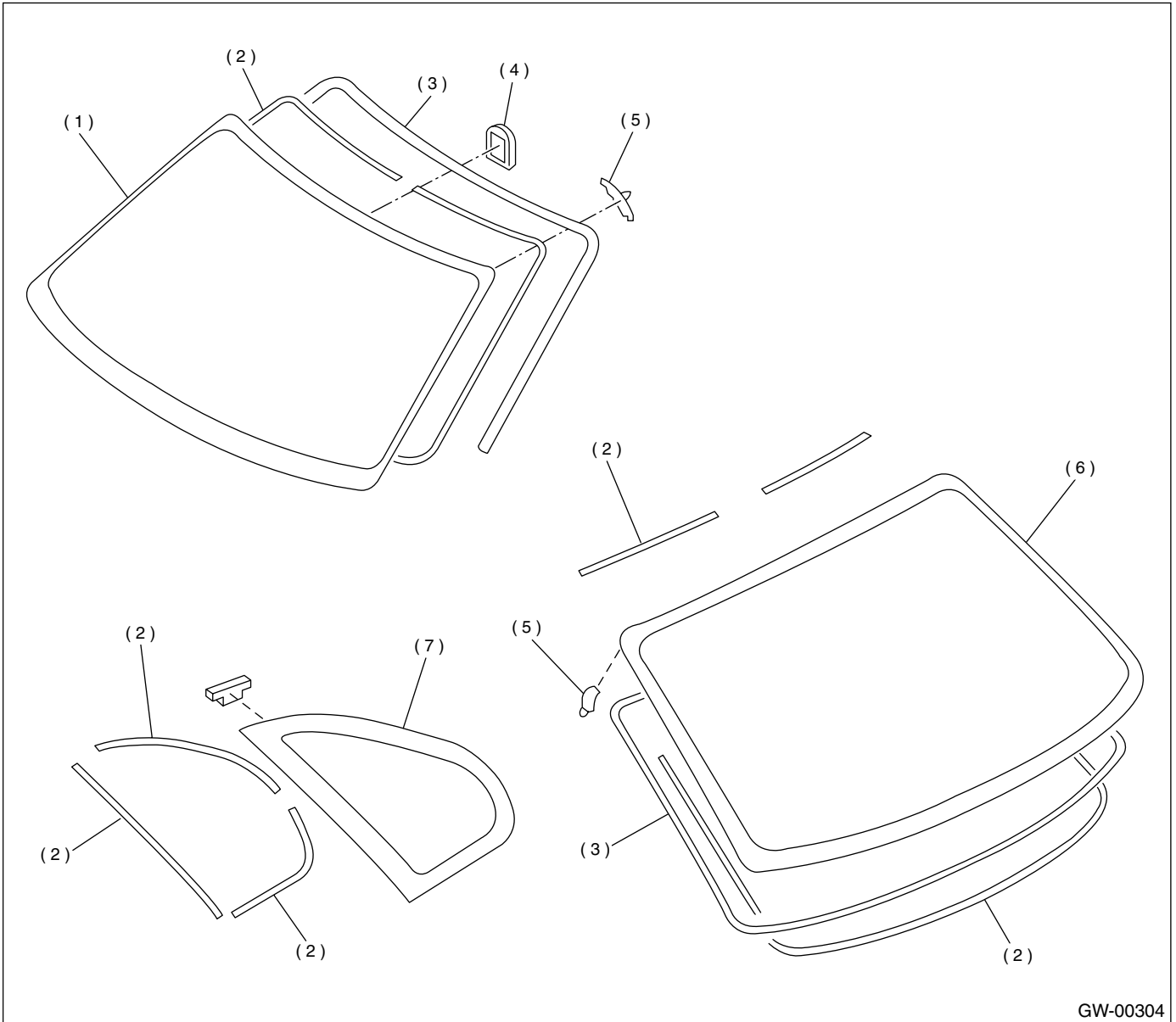

(1) Windshield glass

(2) Dam rubber

(3) Molding

(4) Rearview mirror mount

(5) Locate pin

(6) Rear window glass

(7) 6 light glass

2. FIXED GLASS (WAGON)

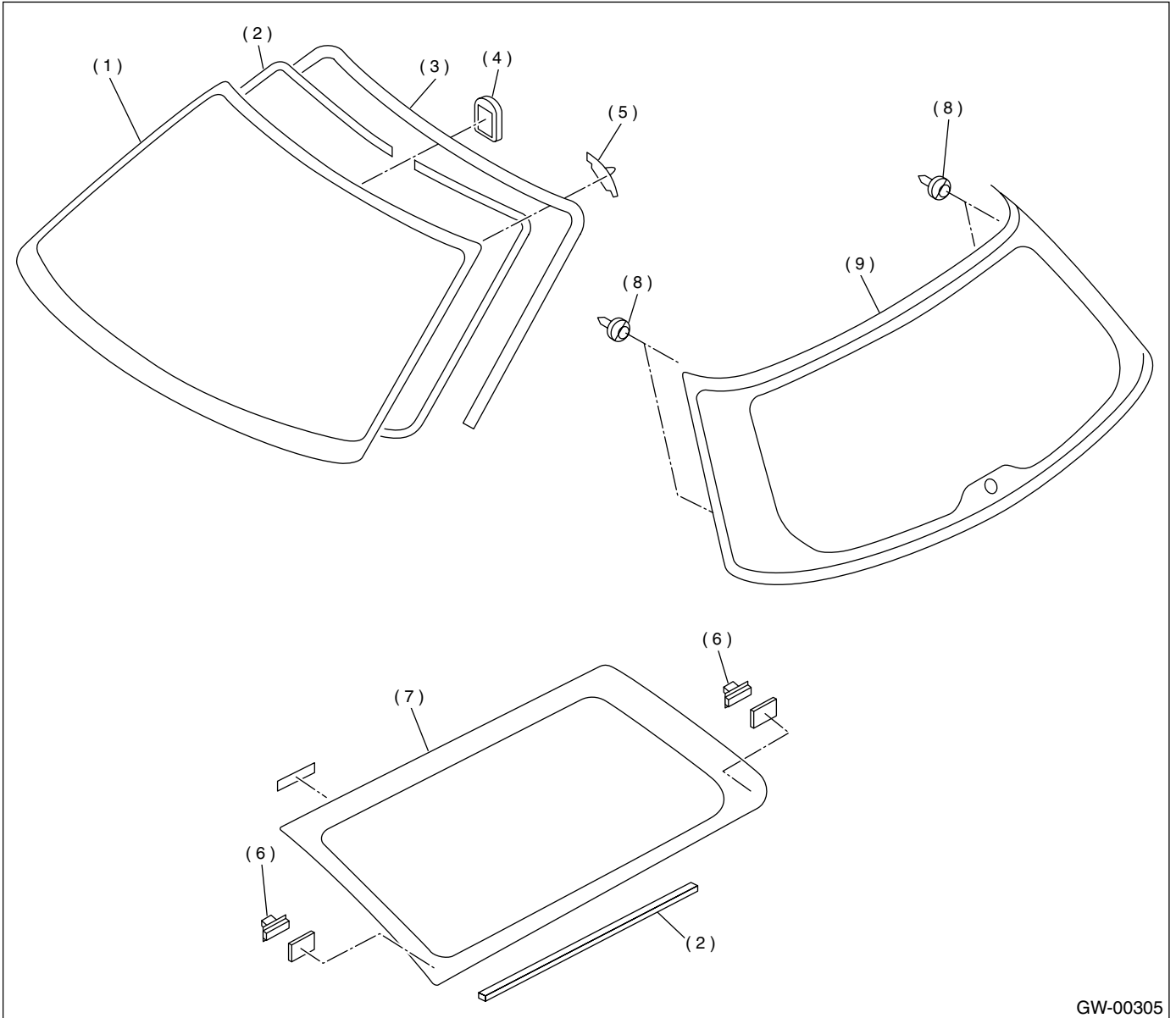

GW-00305

(1) Windshield glass

(2) Dam rubber

(3) Molding

(4) Rearview mirror mount

(5) Locate pin

(6) Fastener

(7) Rear quarter glass

(8) Locate pin

(9) Glass

GENERAL DESCRIPTION

GLASS/WINDOWS/MIRRORS

3. FRONT DOOR GLASS

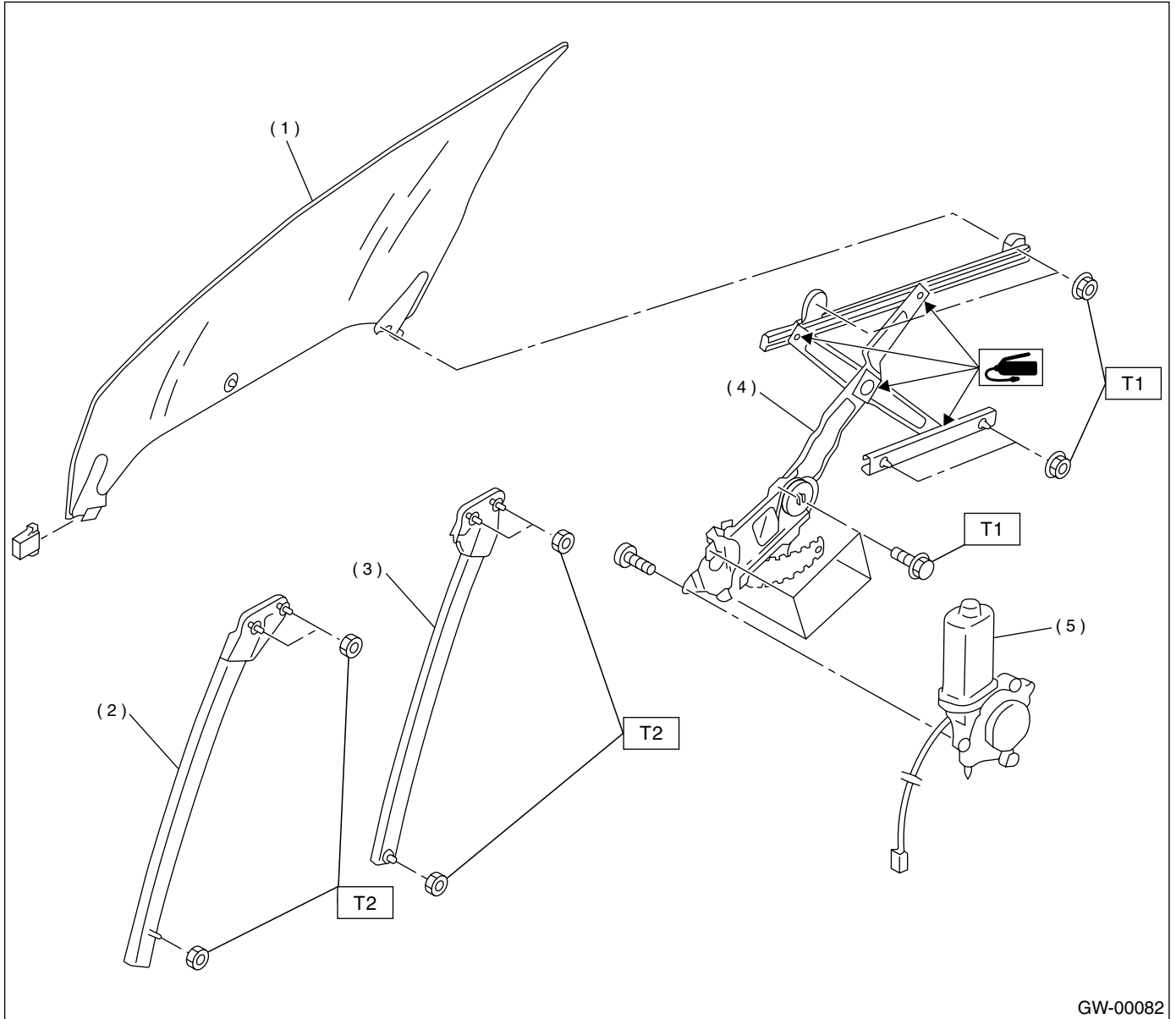

- (1) Glass
- (2) Door sash (Front)
- (3) Door sash (Rear)
- (4) Regulator ASSY

- (5) Motor ASSY

Tightening torque: N·m (kgf·m, ft·lb)

T1: 7.35 (0.75, 5.4)

T2: 14 (1.4, 10.1)

4. REAR DOOR GLASS

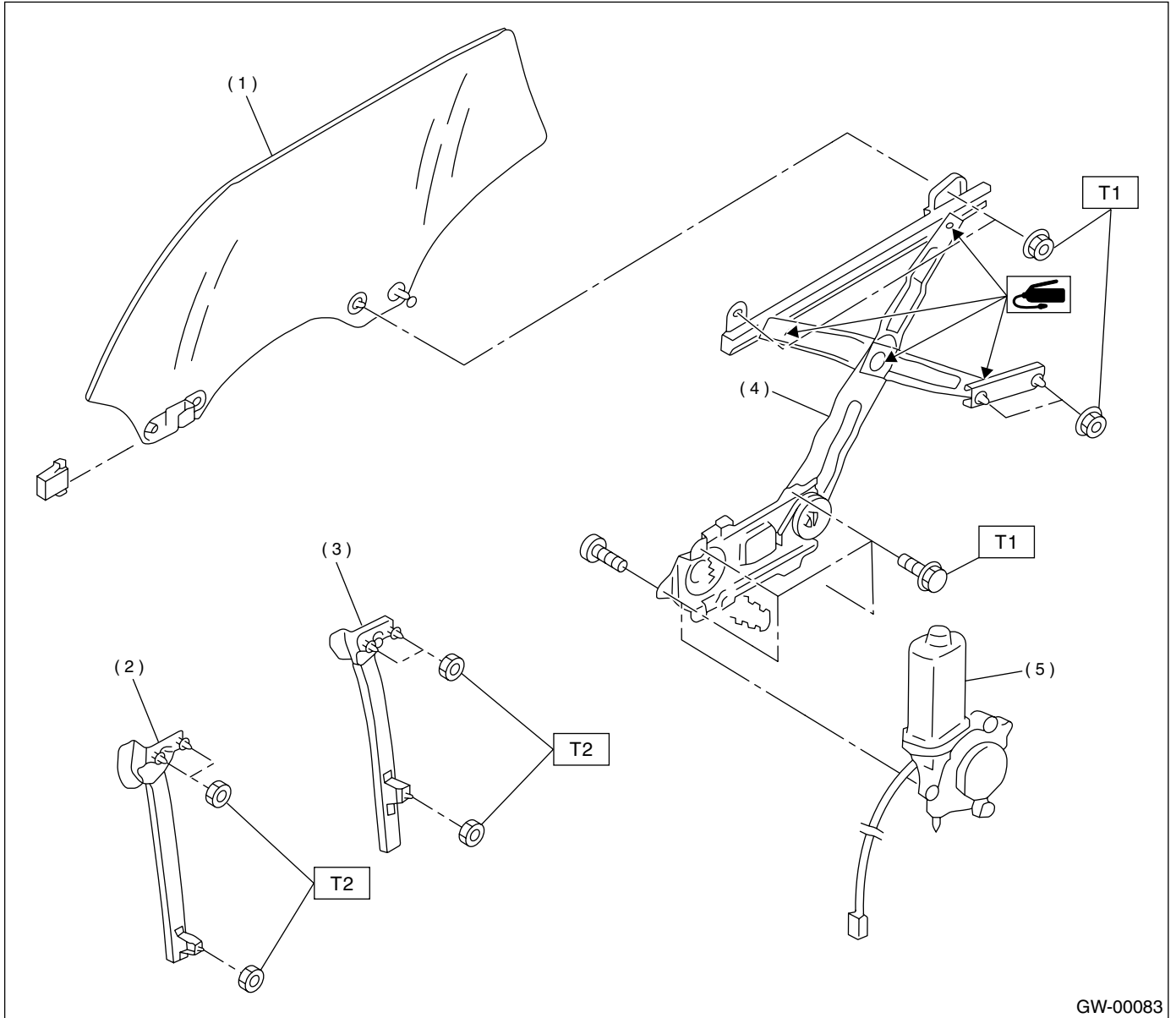

- (1) Glass
- (2) Door sash (Front)
- (3) Door sash (Rear)
- (4) Regulator ASSY

- (5) Motor ASSY

Tightening torque: N·m (kgf·m, ft·lb)

T1: 7.35 (0.75, 5.4)

T2: 14 (1.4, 10.1)

GENERAL DESCRIPTION

GLASS/WINDOWS/MIRRORS

5. MIRRORS

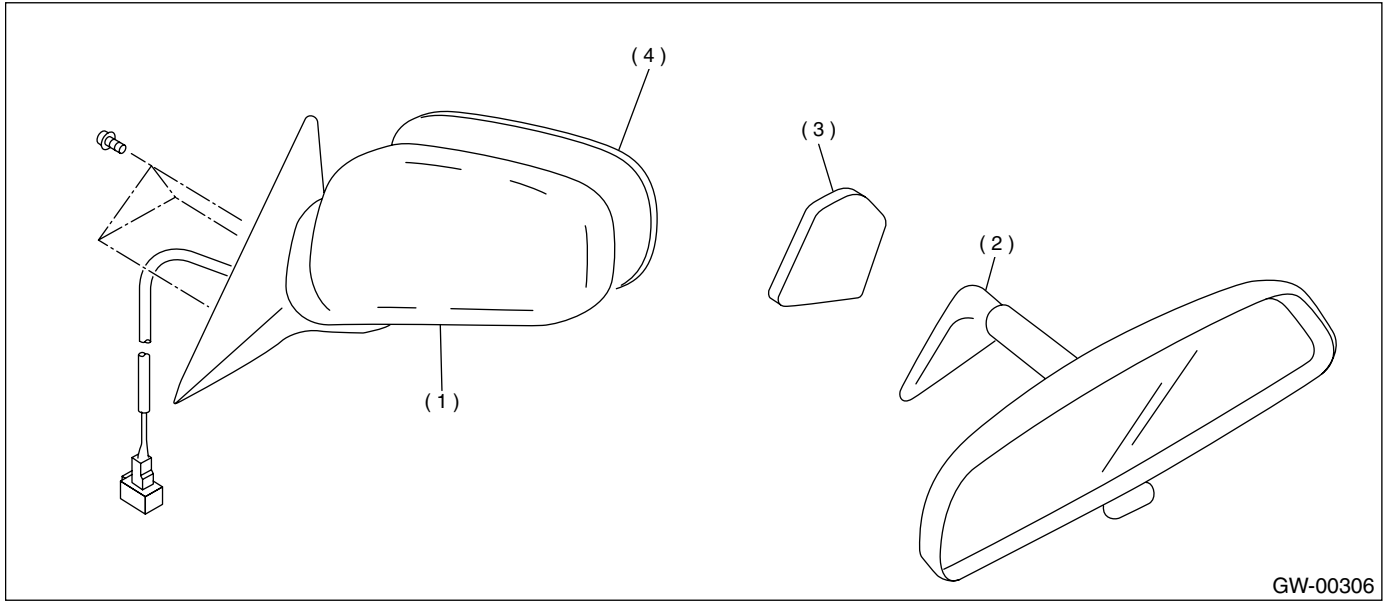

GW-00306

- (1) Outer mirror
- (2) Inner rearview mirror

- (3) Mount
- (4) Mirror

GENERAL DESCRIPTION

GLASS/WINDOWS/MIRRORS

B: CAUTION

- When electrical connectors are disconnected, always conduct an operational check after connecting them again.
- Avoid impact and damage to the glass.

C: PREPARATION TOOL

TOOL NAME	REMARKS
Circuit Tester	Used for checking voltage and continuity.
Piano Wire	Used for window glass removal.
Windshield Knife	Used for window glass removal.

POWER WINDOW SYSTEM

GLASS/WINDOWS/MIRRORS

2. Power Window System

A: SCHEMATIC

<Ref. to WI-262, Power Window System.>

B: INSPECTION

Symptom	Repair order
All power windows does not operate.	(1) Fuse (SBF-6) (F/B No. 18) (2) Power window circuit breaker (3) Power window relay (4) Wiring harness
One window does not operate.	(1) Power window main switch (2) Power window sub switch (3) Power window motor (4) Wiring harness
"Window Lock" does not operate.	(1) Power window main switch

REAR WINDOW DEFOGGER SYSTEM

GLASS/WINDOWS/MIRRORS

3. Rear Window Defogger System

A: SCHEMATIC

<Ref. to WI-271, SCHEMATIC, Rear Window Defogger System.>

B: INSPECTION

Symptom	Repair order
Rear window defogger does not operate.	(1) Fuse (M/B No. 1) (2) Rear defogger relay (3) Defogger switch (4) Rear defogger condenser (5) Defogger wire (6) Wiring harness

WINDSHIELD WIPER DEICER SYSTEM

GLASS/WINDOWS/MIRRORS

4. Windshield Wiper Deicer System

A: SCHEMATIC

<Ref. to WI-298, Wiper Deicer System.>

B: INSPECTION

Symptom	Repair order
Wiper deicer does not operate.	(1) Fuse (F/B No. 18, 19) (2) Wiper deicer relay (3) Wiper deicer switch (4) Wiring harness

REMOTE CONTROL MIRROR SYSTEM

GLASS/WINDOWS/MIRRORS

5. Remote Control Mirror System

A: SCHEMATIC

<Ref. to WI-273, Remote Controlled Rearview Mirror System.>

B: INSPECTION

Symptom	Repair order
All function does not operate.	(1) Fuse (F/B No. 4) (2) Mirror switch (3) Wiring harness
One side of the mirror motor does not operate.	(1) Mirror switch (2) Mirror motor (3) Wiring harness
Mirror heater does not operate.	(1) Mirror switch (2) Mirror heater (3) Wiring harness

FRONT DOOR GLASS

GLASS/WINDOWS/MIRRORS

6. Front Door Glass

A: REMOVAL

- 1) Remove door trim. <Ref. to EI-40, REMOVAL, Front Door Trim.>
- 2) Remove sealing cover. <Ref. to EB-15, REMOVAL, Front Sealing Cover.>
- 3) Remove outer weatherstrip.
- 4) Remove inner stabilizer.

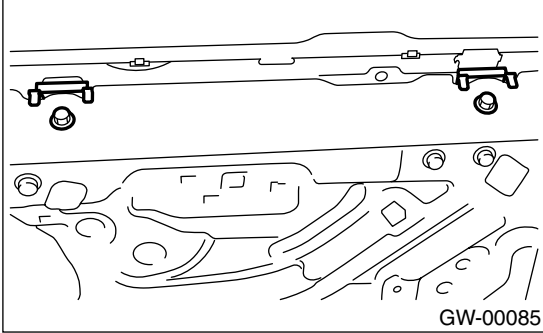

- 5) Remove outer mirror. <Ref. to GW-33, REMOVAL, Outer Mirror Assembly.>
- 6) Remove gusset.

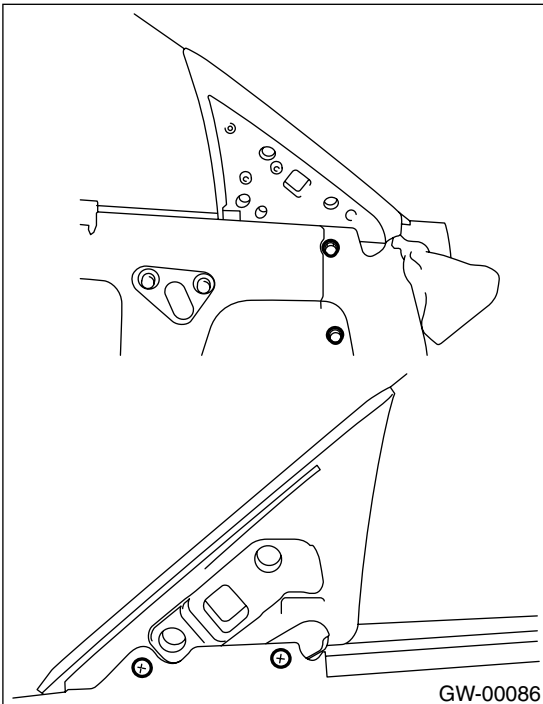

- 7) Operate the power window switch to move glass to the position shown in the figure, and then remove the two nuts from service holes.

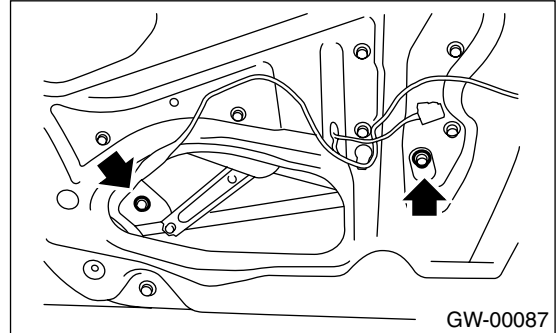

- 8) Take out glass door panel upward.

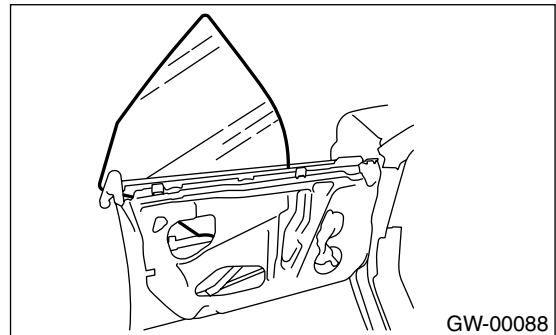

CAUTION:

- Do not turn regulator in the closing direction after removal of the glass. Otherwise gear may be disengaged.
- Avoid impact and damage to the glass.

B: INSTALLATION

- 1) Install in the reverse order of removal.

CAUTION:

Make sure that glass stay is placed securely in sash.

- 2) Adjust front door glass. <Ref. to GW-13, ADJUSTMENT, Front Door Glass.>

Tightening torque:

Refer to COMPONENT in General Description. <Ref. to EB-4, FRONT DOOR PANEL, COMPONENT, General Description.> and <Ref. to GW-4, FRONT DOOR GLASS, COMPONENT, General Description.>

C: ADJUSTMENT

NOTE:

Before adjustment, ensure that all adjusting bolts of stabilizer, upper stopper, and sash are loose and door glass is raised so that it is in contact with weatherstrip.

1) Temporarily tighten one adjusting bolt on one side of rear sash at the midpoint of slotted hole in the inner panel.

2) Temporarily tighten regulator B-channel in a position slightly lower than midpoint of slotted hole.

3) Lower door glass 10 to 15 mm (0.39 to 0.59 in) from fully closed position. While applying outward pressure of 45 ± 5 N (4.59 ± 0.51 kgf, 10.1 ± 1.1 lb) (F) to upper edge of glass above midpoint of two outer stabilizers, press inner stabilizer at 10 ± 5 N (1.02 ± 0.51 kgf, 2.2 ± 1.1 lb) until it just touches the glass, then secure it.

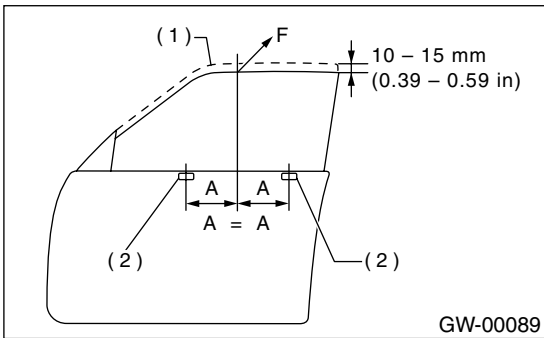

- (1) Full close
- (2) Stabilizer

4) For adjustment of clearance between front and rear glasses, loosen nuts (A), and move glass sash back and forth until clearance becomes the value shown.

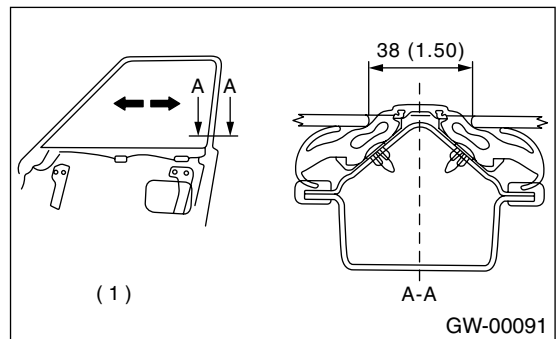
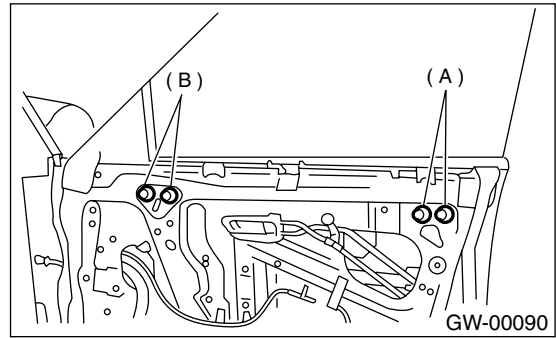

(1) Unit: mm (in)

5) For adjustment of upper and lower ends of center pillar, loosen adjusting nut (A) of B-channel (B).

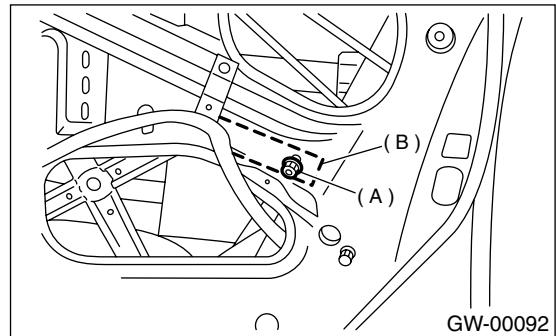

FRONT DOOR GLASS

GLASS/WINDOWS/MIRRORS

6) Adjust so that upper and lower ends of center pillar are the same size.

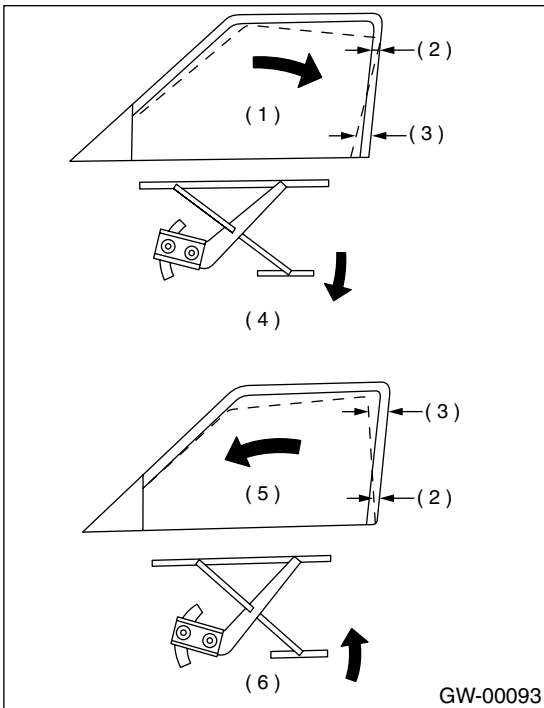

- (1) Glass tilts too far rearward
- (2) Narrow
- (3) Wide
- (4) Lower B channel
- (5) Glass tilts too far forward
- (6) Raise B channel

7) For glass stroke adjustment, close door, raise glass until positional relationship between glass and weatherstrip becomes as shown. And secure the glass so that upper stopper lightly touches the glass holder.

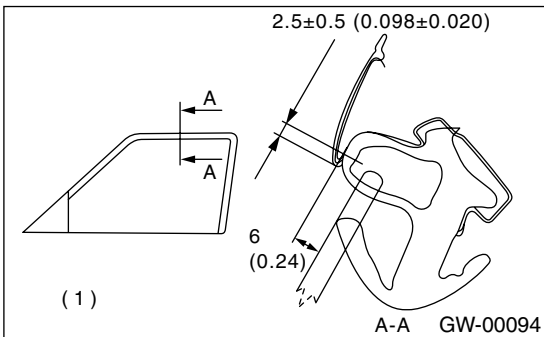

(1) Unit: mm (in)

8) After stabilizer adjustment, carry out glass crimp adjustment. First, visually ensure positional relationship between retainer & molding and glass of the roof side, and then begin with rear sash adjustment. Adjust two adjusting bolts alternately step by step to obtain dimensions shown below (cross-section A).

NOTE:

If two nuts are loosened at the same time, sash moves back and forth. Therefore, when one nut is adjusted, secure the other.

9) Make the same adjustment of two adjusting bolts of rear sash.

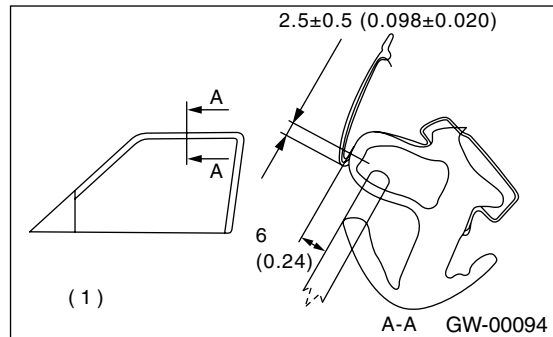

(1) Unit: mm (in)

CAUTION:

Do not tilt sash bracket to inner panel during adjustment. Otherwise smooth regulator operation cannot be achieved.

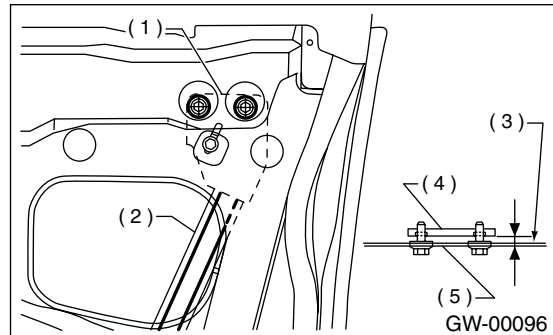

- (1) Sash bracket
- (2) Rear sash
- (3) Adjust a line parallel
- (4) Sash
- (5) Inner panel

10) Make adjustment of front sash in the same manner as that of rear sash.

CAUTION:

Although front and rear sashes must, as a rule, be adjusted in the same manner, in some door installation, the adjustment in a different manner may be required. However, adjustment of one sash to the maximum amount and the other to the minimum amount is not permitted. Such adjustment may result in application of excessive load to regulator.

11) After adjustments, tighten nuts.

12) After adjustment of glass, if there is a gap between outer lip of gusset and glass surface, adjust the gap with adjusting bolt (A) in lower fitting part of gusset to prevent generation of wind noise.

13) During adjustments, loosen other three clamping bolts.

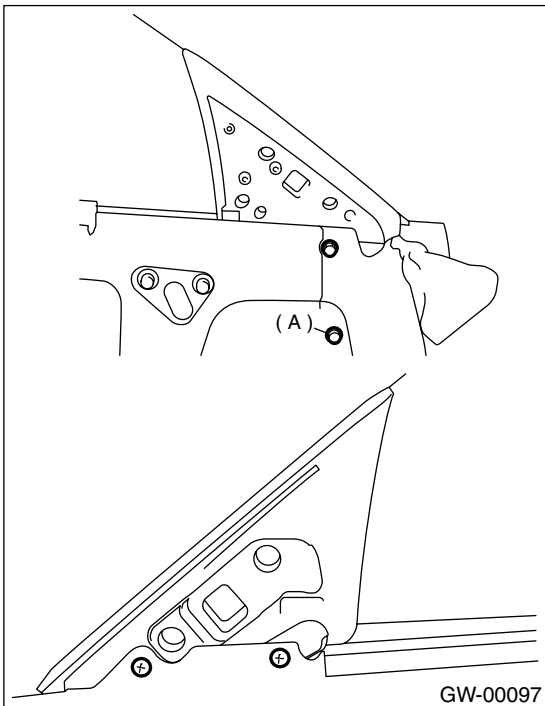

14) After adjustment, tighten bolts and nuts.

FRONT REGULATOR AND MOTOR ASSEMBLY

GLASS/WINDOWS/MIRRORS

7. Front Regulator and Motor Assembly

2) Change polarity of battery connections to terminals to ensure that motor rotates in reverse direction.

A: REMOVAL

- 1) Remove door trim. <Ref. to EI-40, REMOVAL, Front Door Trim.>
- 2) Remove sealing cover. <Ref. to EB-15, REMOVAL, Front Sealing Cover.>
- 3) Remove inner remote. <Ref. to SL-33, REMOVAL, Front Inner Remote.>
- 4) Remove door glass. <Ref. to GW-12, REMOVAL, Front Door Glass.>
- 5) Disconnect electrical connector.
- 6) Loosen four bolts and two nuts to pull out regulator assembly.

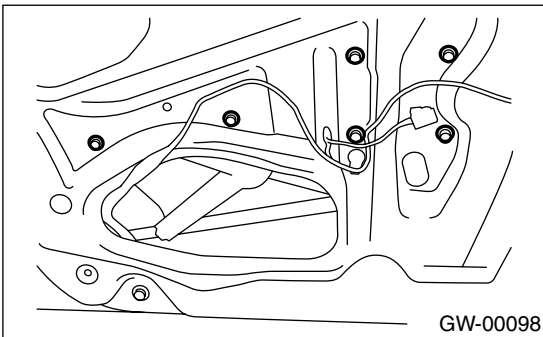

- 7) Loosen screws to remove motor assembly.

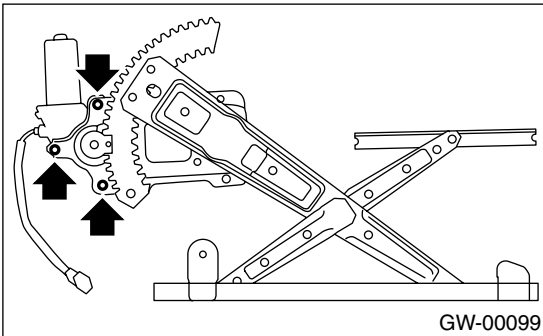

B: INSTALLATION

- 1) Install in the reverse order of removal.
- 2) Adjust front door glass. <Ref. to GW-13, Adjustment.>

Tightening torque:

Refer to COMPONENT in General Description. <Ref. to EB-4, FRONT DOOR PANEL, COMPONENT, General Description.> and <Ref. to GW-4, FRONT DOOR GLASS, COMPONENT, General Description.>

C: INSPECTION

- 1) Make sure that power window motor rotates properly when battery voltage is applied to terminals of motor connector.

8. Rear Door Glass

A: REMOVAL

- 1) Remove door trim. <Ref. to EI-41, REMOVAL, Rear Door Trim.>
- 2) Remove sealing cover. <Ref. to EB-18, REMOVAL, Rear Sealing Cover.>
- 3) Remove stabilizer.

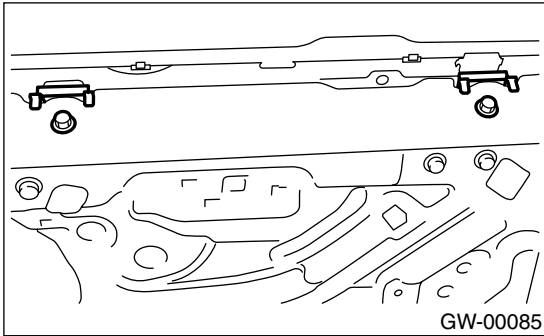

- 4) Operate power window switch to move glass as shown in the figure, and remove two nuts.

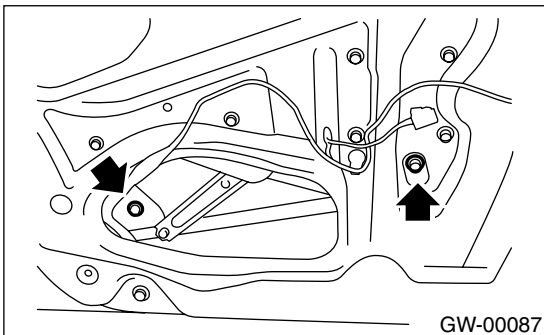

- 5) Loosen two screws to remove weatherstrip.

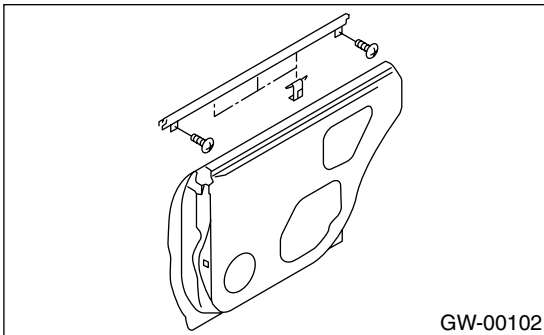

- 6) Pull out glass.

CAUTION:

Avoid impact and damage to the glass.

B: INSTALLATION

- 1) Install in the reverse order of removal.

CAUTION:

Make sure that glass stay is placed securely in sash.

- 2) Adjust rear door glass. <Ref. to GW-17, ADJUSTMENT, Rear Door Glass.>

Tightening torque:

Refer to COMPONENT in General Description. <Ref. to EB-5, REAR DOOR PANEL, COMPONENT, General Description.> and <Ref. to GW-5, REAR DOOR GLASS, COMPONENT, General Description.>

C: ADJUSTMENT

NOTE:

Rear door glass, as a rule, should be adjusted in the same manner as front glass, although they are different in dimension. Special notes for rear glass are given below.

- 1) Adjust glass position using the following dimensions as a guide line.

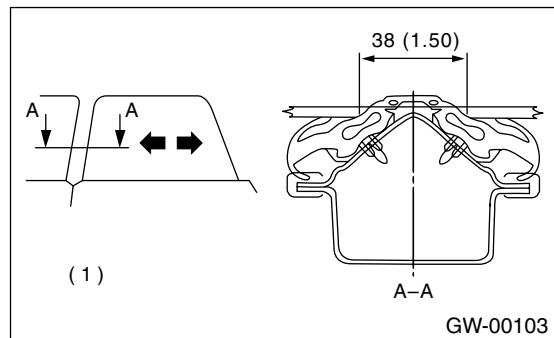

(1) Unit: mm (in)

CAUTION:

- If dimensions are smaller than the given dimensions, glass may get caught in weatherstrip during lifting/lowering operation. In the worst case, it may cause glass not to be opened fully.
- After adjustment, move glass up and down to check whether it is caught.

REAR DOOR GLASS

GLASS/WINDOWS/MIRRORS

2) Adjust crimp of glass using the following dimensions as a guide line.

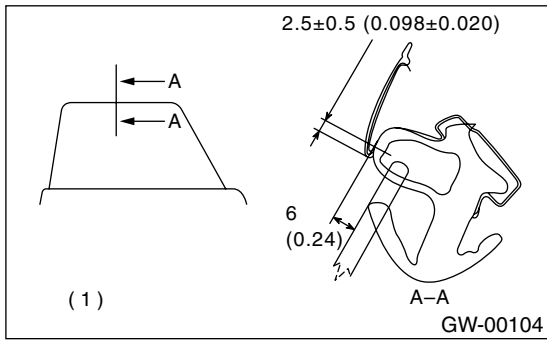

(1) Unit: mm (in)

CAUTION:

- If crimp of rear glass is higher than necessary, glass may get caught in weatherstrip of center pillar corner, resulting in early wear of weatherstrip. Be careful when adjusting.
- After adjustment, move glass up and down to check whether it is caught.

9. Rear Regulator and Motor Assembly

A: REMOVAL

- 1) Remove door trim. <Ref. to EI-41, REMOVAL, Rear Door Trim.>
- 2) Remove sealing cover. <Ref. to EB-18, REMOVAL, Rear Sealing Cover.>
- 3) Remove door glass. <Ref. to GW-17, REMOVAL, Rear Door Glass.>
- 4) Secure bolts using screwdriver to remove front sash adjusting nut.

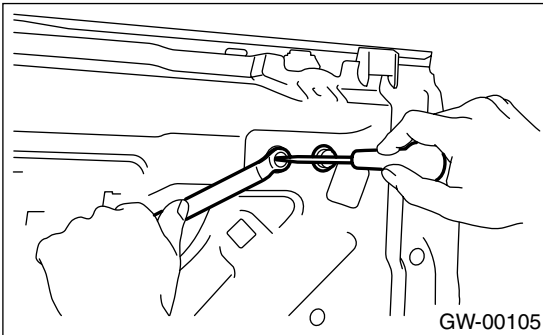

- 5) Remove front sash.
- 6) Disconnect electrical connector.
- 7) Loosen four bolts and two nuts to remove regulator assembly.

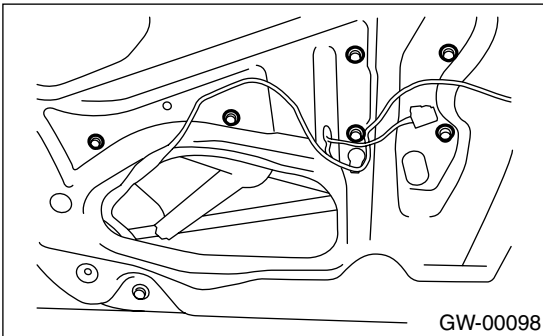

- 8) Loosen screws to remove motor assembly.

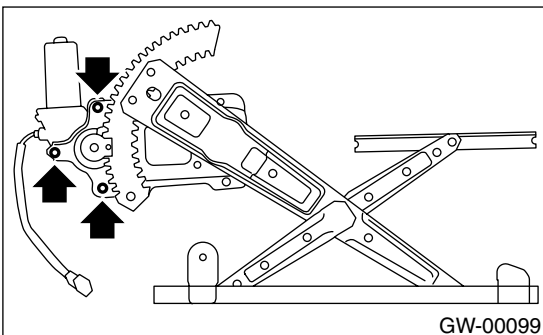

B: INSTALLATION

- 1) Install in the reverse order of removal.
- 2) Adjust rear door glass. <Ref. to GW-17, ADJUSTMENT, Rear Door Glass.>

Tightening torque:

Refer to COMPONENT in General Description. <Ref. to EB-5, REAR DOOR PANEL, COMPONENT, General Description.> and <Ref. to GW-5, REAR DOOR GLASS, COMPONENT, General Description.>

C: INSPECTION

- 1) Make sure that power window motor rotates properly when battery voltage is applied to terminals of motor connector.
- 2) Change polarity of battery connections to terminals to ensure that motor rotates in reverse direction.

10. Windshield Glass

A: REMOVAL

1. USING WINDSHIELD KNIFE

- 1) Remove cowl panel. <Ref. to EI-35, REMOVAL, Cowl Panel.>
- 2) Remove front molding.
- 3) Tape body side of the circumference of windshield glass for protection.
- 4) Apply sufficient amount of soapy water to adhesive layer.
- 5) Insert windshield knife into the adhesive layer.
- 6) While holding the knife edge and windshield glass edge at a right angle, move windshield knife in parallel to windshield glass edge along face and edge of windshield glass to cut the adhesive layer.

CAUTION:

- Do not twist windshield knife.
- Cutting of adhesive layer shall be started with wider gap between windshield glass and body.

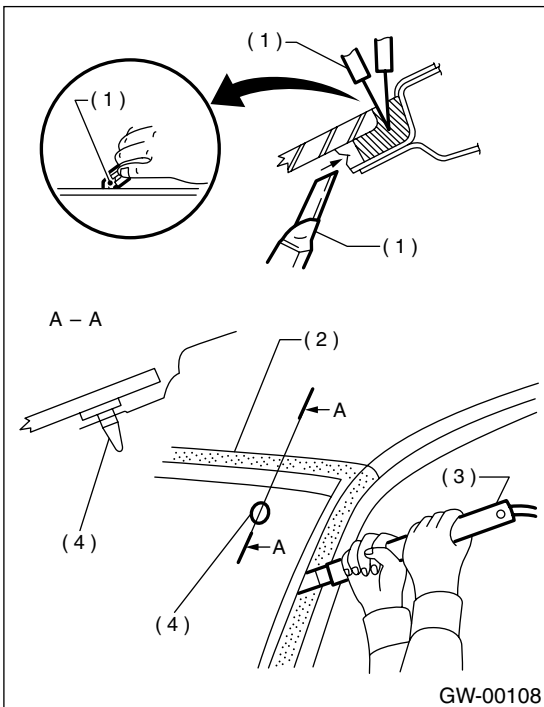

- (1) Putty knife
- (2) Protective tape
- (3) Windshield knife
- (4) Matching pin

NOTE:

Because matching pins are bonded to the corners of glass, use piano wire to cut the pin.

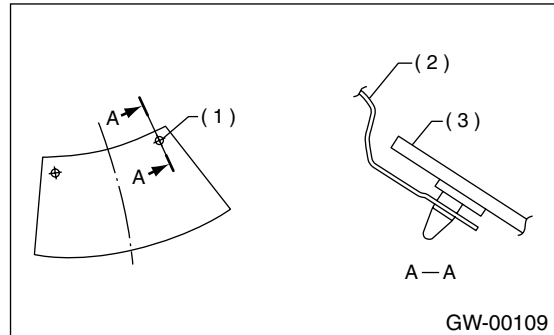

- (1) Matching pin
- (2) Body panel
- (3) Glass

2. USING PIANO WIRE

- 1) Remove cowl panel. <Ref. to EI-35, REMOVAL, Cowl Panel.>
- 2) Remove front molding.
- 3) Tape the body side of the circumference of windshield glass for protection.
- 4) Make a hole in adhesive layer using drill or knife.
- 5) Pass piano wire through the hole, and attach securely both the wire ends to pieces of wood.

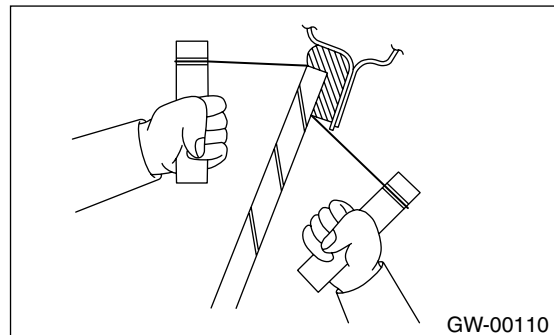

- 6) Pull the wire ends alternately to cut off the adhesive layer.

CAUTION:

- Do not tightly pull the piano wire against the windshield glass edge.
- Be careful not to damage interior and exterior parts.
- When removal is made with area close to instrument panel, place a protection plate over it. Pay particular attention to the removal.
- Do not cross piano wires. Otherwise they may be cut.

B: INSTALLATION

- 1) Clean external circumference of windshield glass with alcohol or white gasoline.
- 2) Remove adhesive layer on the body using cutter knife to obtain smooth face 2 mm (0.08 in) thick.

CAUTION:

Be careful not to damage the body and paint surface.

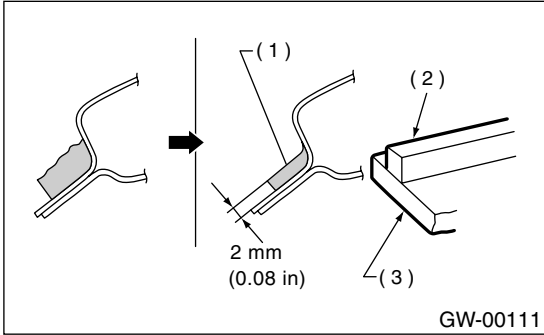

- (1) Adhesive
- (2) Dam rubber
- (3) Glass

- 3) Clean body with alcohol or white gasoline to remove thoroughly chips, dusts, and dirt from body face.
- 4) Place glass on body.
- 5) Adjust glass position to make uniform clearance between body and glass in four corners.
- 6) Place matching pins (A) and body on glass.

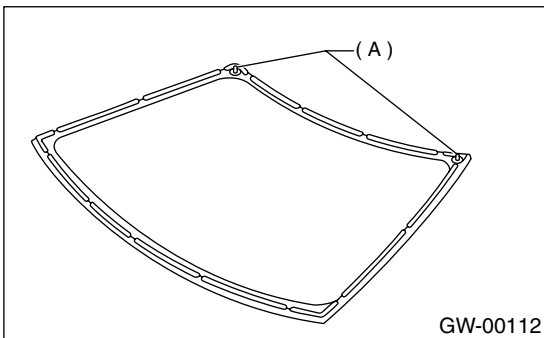

- 7) Remove glass from body.

- 8) Fit molding mark (B) to notch (A) of ceramic print.

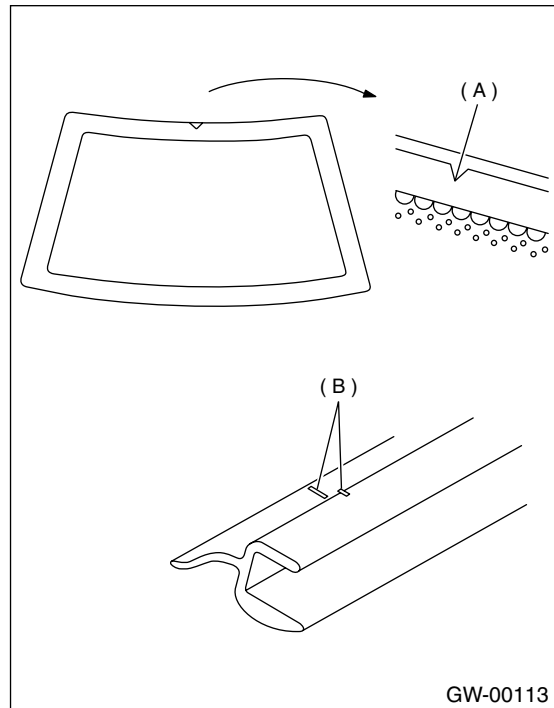

- 9) Apply primer to adhesive layer (A) of glass (B) using sponge.
- 10) Apply primer to adhesive layer (A) of body (C).

CAUTION:

- Primer once attached to the painted surface of the body and internal trim is hard to wipe off. Mask the circumference of such areas.
- Let primer dry for about ten minutes before installing the glass.
- Do not touch surface coated with primer.

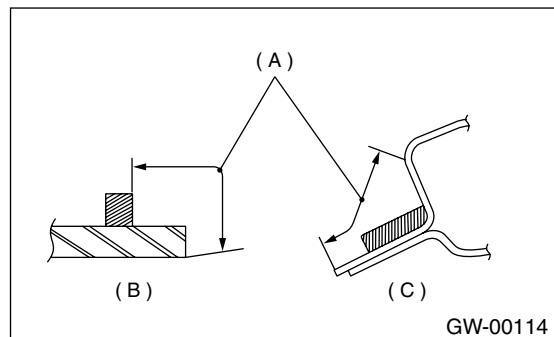

WINDSHIELD GLASS

GLASS/WINDOWS/MIRRORS

11) Cut off cartridge nozzle tip and set it in sealant gun as shown.

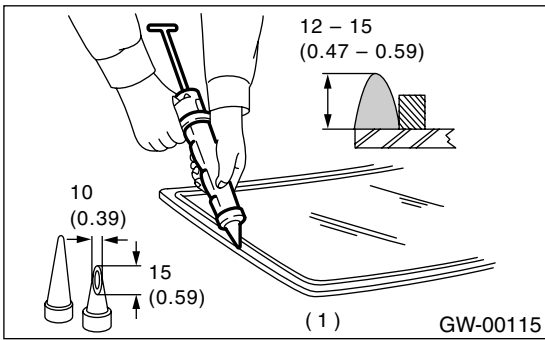

12) Apply adhesive to glass end surface as shown.
13) Fit matching pins using suction rubber cup to install windshield glass.

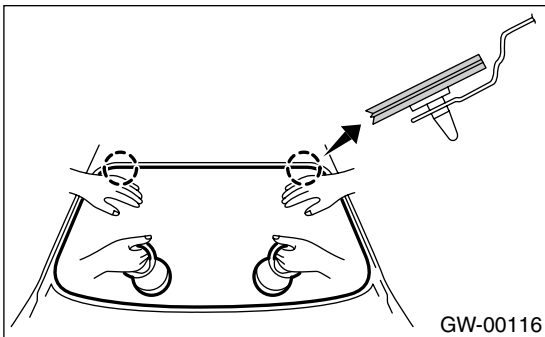

14) Lightly press windshield glass for tight fit.
15) Make adhesive surface flush using spatula.

CAUTION:

- When door is opened/closed after glass is bonded, always lower door glass and then open/close it carefully.
- Move vehicle slowly.

16) After completion of all work, allow vehicle to stand for about 24 hours.

NOTE:

For minimum drying time and time the vehicle must be left standing before driving after bonding, follow instructions or instruction manual from the adhesive manufacturer.

17) After curing of adhesive, pour water on external surface of vehicle to check that there are no water leaks.

CAUTION:

When a vehicle is returned to the user, tell him or her that the vehicle should not be subjected to heavy impact for at least three days.

18) Install cowl panel. <Ref. to EI-35, INSTALLATION, Cowl Panel.>

11. Rear Gate Glass

A: REMOVAL

- 1) Remove rear wiper motor. <Ref. to WW-15, REMOVAL, Rear Wiper Motor.>
- 2) Remove electrical connector from rear defogger terminal.
- 3) Remove glass in the same procedure as for windshield glass. <Ref. to GW-20, REMOVAL, Windshield Glass.>

B: INSTALLATION

- 1) Apply adhesive evenly to the glass attachment area.
- 2) Insert the glass clip pin into the rear gate hole, and after pushing on the area around the clip pin to secure it, push lightly all around the area to seal it.
- 3) About one hour after installation, conduct a leak test.

- 4) After completion of all work, allow vehicle to stand for about 24 hours.

NOTE:

For minimum drying time and time the vehicle must be left standing before driving after bonding, follow instructions or instruction manual from the adhesive manufacturer.

CAUTION:

When a vehicle is returned to the user, tell him or her that the vehicle should not be subjected to heavy impact for at least three days.

- 5) Connect rear defogger terminals.
- 6) Install rear wiper. <Ref. to WW-15, INSTALLATION, Rear Wiper Motor.>

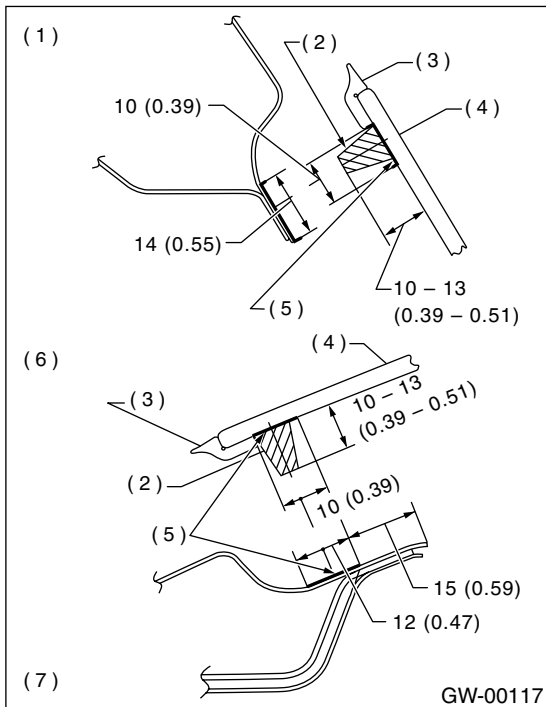

- (1) Upper side
- (2) Adhesive
- (3) Strip rubber
- (4) Glass
- (5) Primer
- (6) Left and right side
- (7) Unit: mm (in)

CAUTION:

- When door is opened/closed after glass is bonded, always lower door glass and then open/close it carefully.
- Move vehicle slowly.

REAR QUARTER GLASS

GLASS/WINDOWS/MIRRORS

12. Rear Quarter Glass

A: REMOVAL

1. SEDAN

Remove glass in the same procedure as for windshield glass. <Ref. to GW-20, REMOVAL, Windshield Glass.>

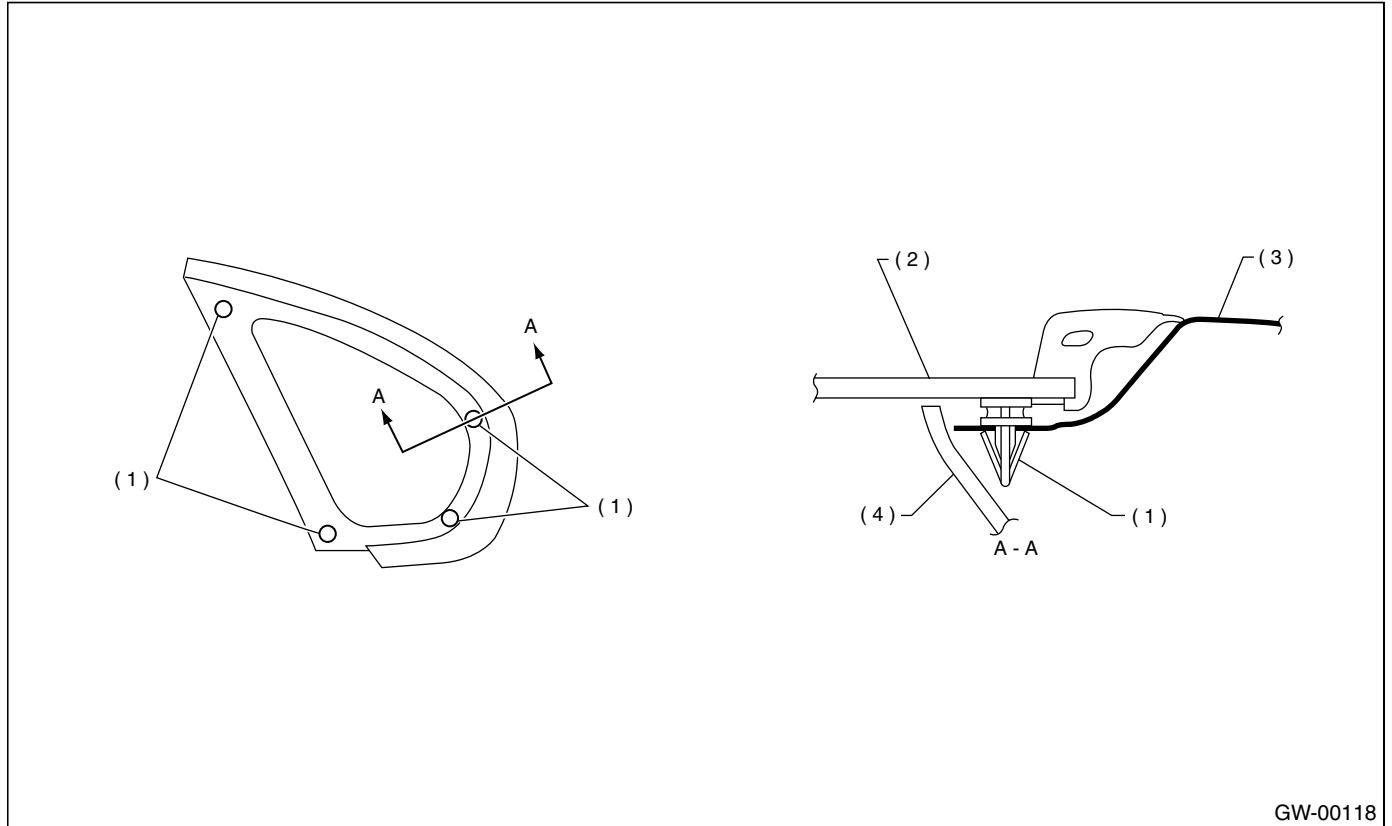

- (1) Matching pin
- (2) Rear quarter glass

- (3) Body panel
- (4) Trim panel

2. WAGON

Remove glass in the same procedure as for windshield glass. <Ref. to GW-20, REMOVAL, Windshield Glass.>

B: INSTALLATION

1) Cut off nozzle tip as shown in the figure.

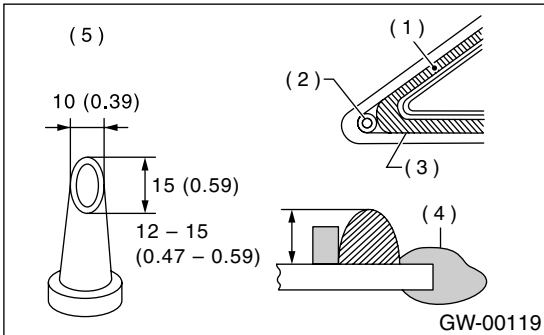

- (1) Dam rubber
- (2) Matching pin
- (3) Adhesive
- (4) Molding
- (5) Unit: mm (in)

2) Install glass in the same procedure as for windshield glass. <Ref. to GW-21, INSTALLATION, Windshield Glass.>

CAUTION:

- When door is opened/closed after glass is bonded, always lower door glass and then open/close it carefully.
- Move vehicle slowly.

3) After completion of all work, allow vehicle to stand for about 24 hours.

NOTE:

For minimum drying time and time the vehicle must be left standing before driving after bonding, follow instructions or instruction manual from the adhesive manufacturer.

4) After curing of adhesive, pour water on external surface of vehicle to check that there are no water leaks.

CAUTION:

When a vehicle is returned to the user, tell him or her that the vehicle should not be subjected to heavy impact for at least three days.

REAR WINDOW GLASS

GLASS/WINDOWS/MIRRORS

13.Rear Window Glass

A: REMOVAL

- 1) Disconnect electrical connectors from rear defogger terminals.
- 2) Remove glass in the same procedure as for windshield glass. <Ref. to GW-20, REMOVAL, Windshield Glass.>

B: INSTALLATION

- 1) Bond dam rubber and matching pin.

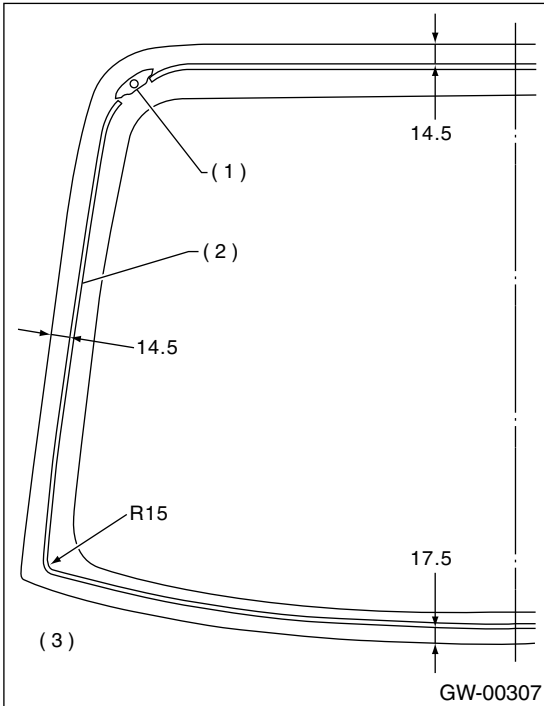

- (1) Matching pin
- (2) Dam rubber
- (3) Unit: mm (in)

- 2) Install glass in the same procedure as for windshield glass. <Ref. to GW-21, INSTALLATION, Windshield Glass.>

- 3) Connect rear defogger terminals.

CAUTION:

- When door is opened/closed after glass is bonded, always lower door glass and then open/close door carefully.
- Move vehicle slowly.

- 4) After completion of all work, allow vehicle to stand for about 24 hours.

NOTE:

For minimum drying time and time the vehicle must be left standing before driving after bonding, follow instructions or instruction manual from the adhesive manufacturer.

- 5) After curing of adhesive, pour water on external surface of vehicle to check that there are no water leaks.

CAUTION:

When a vehicle is returned to the user, tell him or her that the vehicle should not be subjected to heavy impact for at least three days.

14. Roof Window Glass

A: REMOVAL

<Ref. to SR-7, REMOVAL, Sunroof Lid.>

B: INSTALLATION

<Ref. to SR-7, INSTALLATION, Sunroof Lid.>

C: ADJUSTMENT

<Ref. to SR-8, ADJUSTMENT, Sunroof Lid.>

INNER REARVIEW MIRROR

GLASS/WINDOWS/MIRRORS

15.Inner Rearview Mirror

A: REMOVAL

Loosen TORX screw (A) and remove the inner rearview mirror.

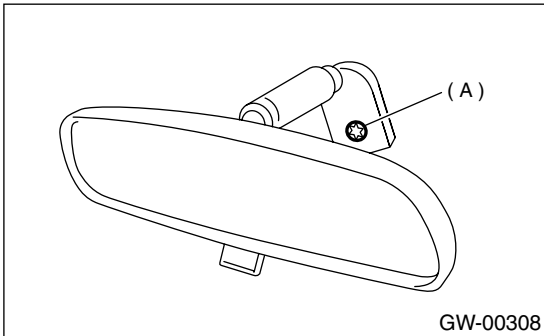

(1) TORX screw

CAUTION:

Be careful not to damage the mirror surface.

B: INSTALLATION

Install in the reverse order of removal.

C: INSPECTION

Do not let mirror be damaged.

16. Power Window Control Switch

A: REMOVAL

1. MAIN SWITCH

1) Remove two hooks (A) of switch panel to remove power window main switch.

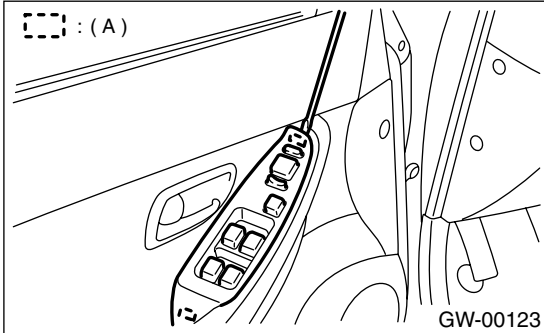

2) Disconnect electrical connectors from power window main switch and mirror switch.

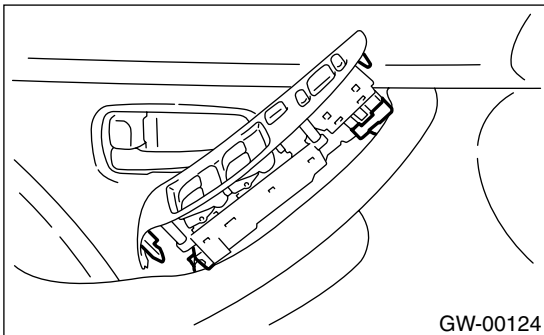

2. SUB-SWITCH

Remove two hooks (A) of switch panel to remove power window sub-switch and disconnect electrical connector.

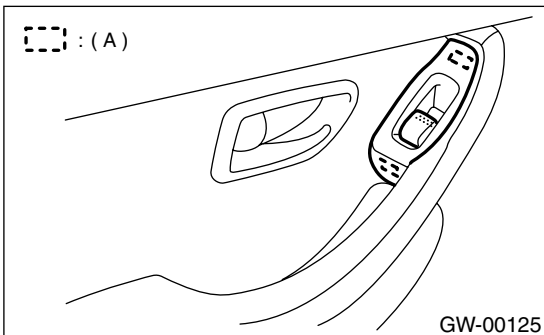

B: INSTALLATION

1. MAIN SWITCH

Install in the reverse order of removal.

2. SUB-SWITCH

Install in the reverse order of removal.

POWER WINDOW CONTROL SWITCH

GLASS/WINDOWS/MIRRORS

C: INSPECTION

1. MAIN SWITCH

Measure switch resistance.

Driver's switch:

Switch position	Terminal No.	Standard
UP	3 and 9, 7 and 1	Less than 1 Ω
OFF	3 and 7 and 1	Less than 1 Ω
DOWN	7 and 9, 3 and 1	Less than 1 Ω
AUTO DOWN	7 and 9, 3 and 1	Less than 1 Ω

Front passenger's switch:

Switch position	Terminal No.	Standard
UP	9 and 5, 1 and 4	Less than 1 Ω
OFF	1 and 5 and 4	Less than 1 Ω
DOWN	9 and 4, 1 and 5	Less than 1 Ω

Rear left switch:

Switch position	Terminal No.	Standard
UP	9 and 13, 1 and 8	Less than 1 Ω
OFF	1 and 13 and 8	Less than 1 Ω
DOWN	9 and 8, 1 and 13	Less than 1 Ω

Rear right switch:

Switch position	Terminal No.	Standard
UP	9 and 16, 1 and 14	Less than 1 Ω
OFF	1 and 16 and 14	Less than 1 Ω
DOWN	9 and 14, 1 and 16	Less than 1 Ω

If defective, replace the main switch.

2. SUB-SWITCH

Measure switch resistance.

Front passenger's door switch and rear door switch:

Switch position	Terminal No.	Standard
UP	5 and 1, 6 and 2	Less than 1 Ω
OFF	4 and 1, 6 and 2	Less than 1 Ω
DOWN	5 and 2, 4 and 1	Less than 1 Ω

If defective, replace the sub-switch.

REAR WINDOW DEFOGGER SWITCH

GLASS/WINDOWS/MIRRORS

17.Rear Window Defogger Switch

A: REMOVAL

<Ref. to AC-31, REMOVAL, Control Unit.>

B: INSTALLATION

<Ref. to AC-31, INSTALLATION, Control Unit.>

C: INSPECTION

Check continuity between connectors at the back of heater control unit.

1. AUTO A/C

Switch position	Terminal No.	Standard
OFF	—	More than 1 MΩ
ON	(i48) 13 and (i49) 12	Less than 1 Ω

2. MANUAL A/C

Switch position	Terminal No.	Standard
OFF	—	More than 1 MΩ
OFF	(i17) 14 and (i17) 10	Less than 1 Ω

REAR WINDOW DEFOGGER

GLASS/WINDOWS/MIRRORS

18.Rear Window Defogger

A: INSPECTION

CAUTION:

When wiping stain on glass off with cloth, use a dry and soft cloth and move it in the direction of the heat wire extension to avoid damage to the heat wire.

- 1) Turn ignition switch to ON.
- 2) Turn defogger switch to ON.
- 3) Wrap tips of tester pins with aluminum foil to avoid damage to heat wire.

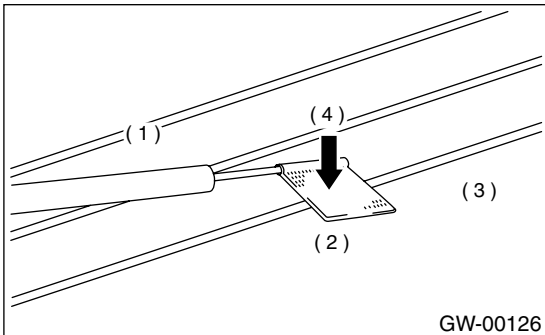

- (1) Tester probe
- (2) Tin foil
- (3) Heat wire
- (4) PRESS

4) Measure voltage at wire center (A) with DC voltmeter.

Standard voltage:

Approx. 6 volts

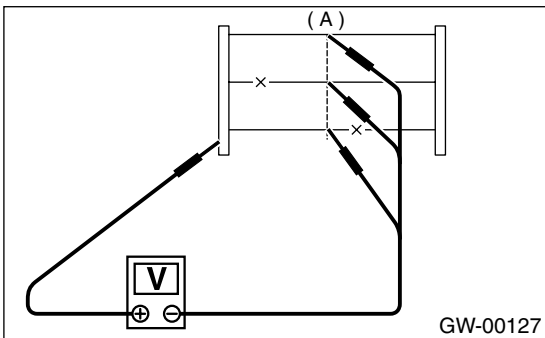

Voltage	Criteria
Approx. 6 V	OK
Approx. 12 V or 0 V	Broken

NOTE:

- If the measured value is 12 volts, heat wire is open between wire center and positive (+) end.
- If zero volt, heat wire is open between wire center and ground.

5) Apply positive lead of voltmeter to positive terminal of voltmeter, and then move negative lead along the wire up to the negative terminal end. If voltage changes from zero to several volts during movement of lead, heat wire is open at the voltage change point.

B: REPAIR

- 1) Clean broken portion with alcohol or white gasoline.
- 2) Mask both side of wire with thin film.
- 3) Apply conductive silver composition (DUPONT No. 4817) to broken portion.

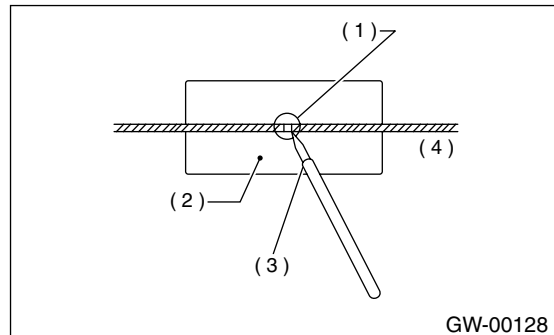

- (1) Broken portion
- (2) Masking thin film
- (3) Conductive silver composition
- (4) Broken wire

4) After repair, check wire.

19. Outer Mirror Assembly

A: REMOVAL

- 1) Remove door trim. <Ref. to EI-40, REMOVAL, Front Door Trim.>
- 2) Pull off sealing cover to disconnect mirror harness connector.

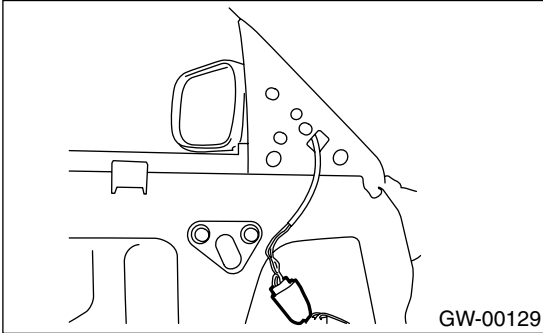

- 3) Remove screws to remove mirror assembly.

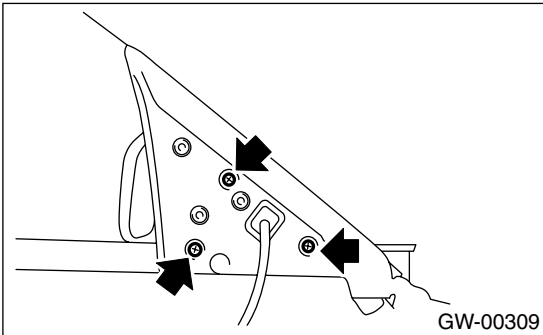

B: INSTALLATION

Install in the reverse order of removal.

C: INSPECTION

Check to ensure that rearview mirror moves properly when battery voltage is applied to terminals.

Switch position	Terminal No.
OFF	—
UP	1 (+) and 3 (-)
DOWN	3 (+) and 1 (-)
LEFT	2 (+) and 3 (-)
RIGHT	3 (+) and 2 (-)

If defective, replace the mirror.

20. Outer Mirror

A: REPLACEMENT

- 1) Remove the door mirror assembly. <Ref. to GW-33, REMOVAL, Outer Mirror Assembly.>
- 2) Warm the area around the mirror holder (A) with a hair drier until the edges of the mirror holder become soft (about 2 or 3 minutes with a 1,000 W drier.)
- 3) Use a flat-bladed screwdriver without sharp edges to lift the mirror out of the mirror holder (A). (Also remove the connector from the back of mirrors with heaters.)

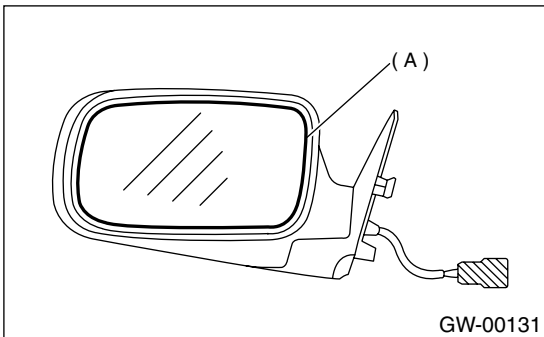

- 4) Warm the area around the mirror holder (A) with a hair drier until the edges of the mirror holder (A) become soft (about 2 or 3 minutes with a 1,000 W drier.)
- 5) Remove the backing of the new two-sided tape, and push the mirror in to install it.

CAUTION:

Unless the mirror holder is warmed sufficiently, the mirror holder edges may be damaged or the mirror cracked.

21. Remote Control Mirror Switch

B: INSTALLATION

Install in the reverse order of removal.

A: REMOVAL

1) Remove power window main switch panel.

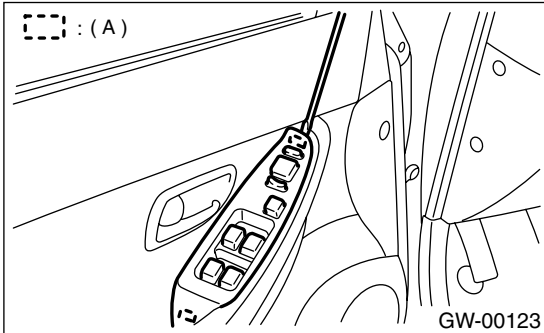

2) Remove four hook (A) to remove remote control mirror switch.

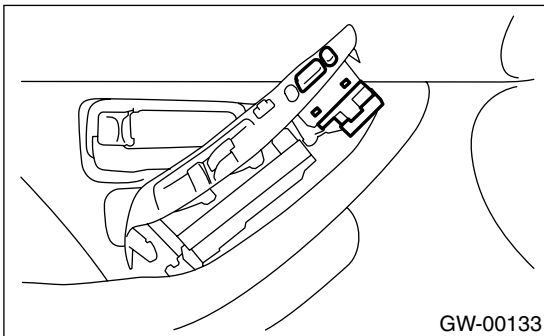

C: INSPECTION

Move rearview mirror switch to each position and check continuity between terminals.

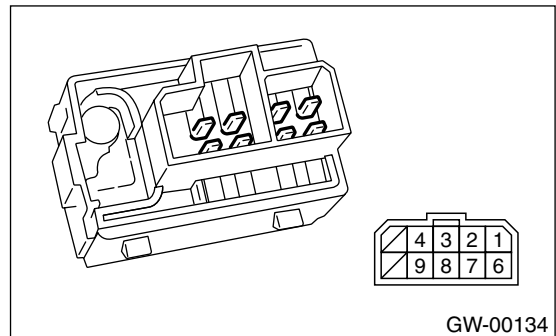

Change over switch left position:

Switch position	Terminal No.	Standard
OFF	—	More than 1 MΩ
UP	7 and 4, 2 and 1	Less than 1 Ω
DOWN	7 and 2, 4 and 1	Less than 1 Ω
LEFT	9 and 4, 2 and 1	Less than 1 Ω
RIGHT	9 and 2, 4 and 1	Less than 1 Ω

Change over switch right position:

Switch position	Terminal No.	Standard
OFF	—	More than 1 MΩ
UP	6 and 4, 2 and 1	Less than 1 Ω
DOWN	6 and 2, 4 and 1	Less than 1 Ω
LEFT	8 and 4, 2 and 1	Less than 1 Ω
RIGHT	8 and 2, 4 and 1	Less than 1 Ω

If defective, replace the switch.

22. Wiper Deicer

A: INSPECTION

Refer to INSPECTION under Rear Window Defogger. <Ref. to GW-32, INSPECTION, Rear Window Defogger.>

B: REPAIR

Refer to REPAIR under Rear Window Defogger. <Ref. to GW-32, REPAIR, Rear Window Defogger.>

23.Wiper Deicer Switch

A: REMOVAL

Remove driver side switch panel, and then remove wiper deicer switch.

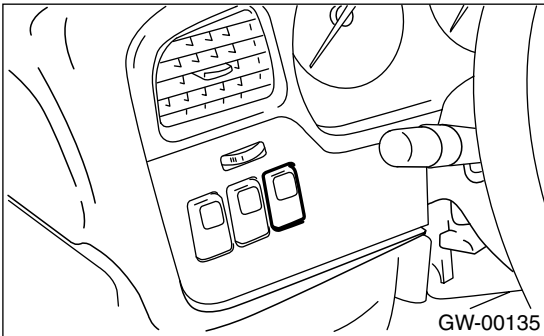

B: INSTALLATION

Install in the reverse order of removal.

C: INSPECTION

Move wiper deicer switch to each position and check continuity between terminals.

Switch position	Terminal No.	Standard
OFF	—	More than 1 MΩ
ON	3 and 5	Less than 1 Ω

If defective, replace the switch.

WIPER DEICER SWITCH

GLASS/WINDOWS/MIRRORS

MEMO: