

CRUISE CONTROL SYSTEM



	Page
1. General Description	2
2. Actuator.....	5
3. Cruise Control Module	6
4. Cruise Control Main Switch.....	7
5. Cruise Control Command Switch	8
6. Stop and Brake Switch.....	9
7. Clutch Switch	10
8. Inhibitor Switch.....	11

GENERAL DESCRIPTION

CRUISE CONTROL SYSTEM

1. General Description

A: COMPONENT

1. MODEL WITH ELECTRONIC CONTROL THROTTLE

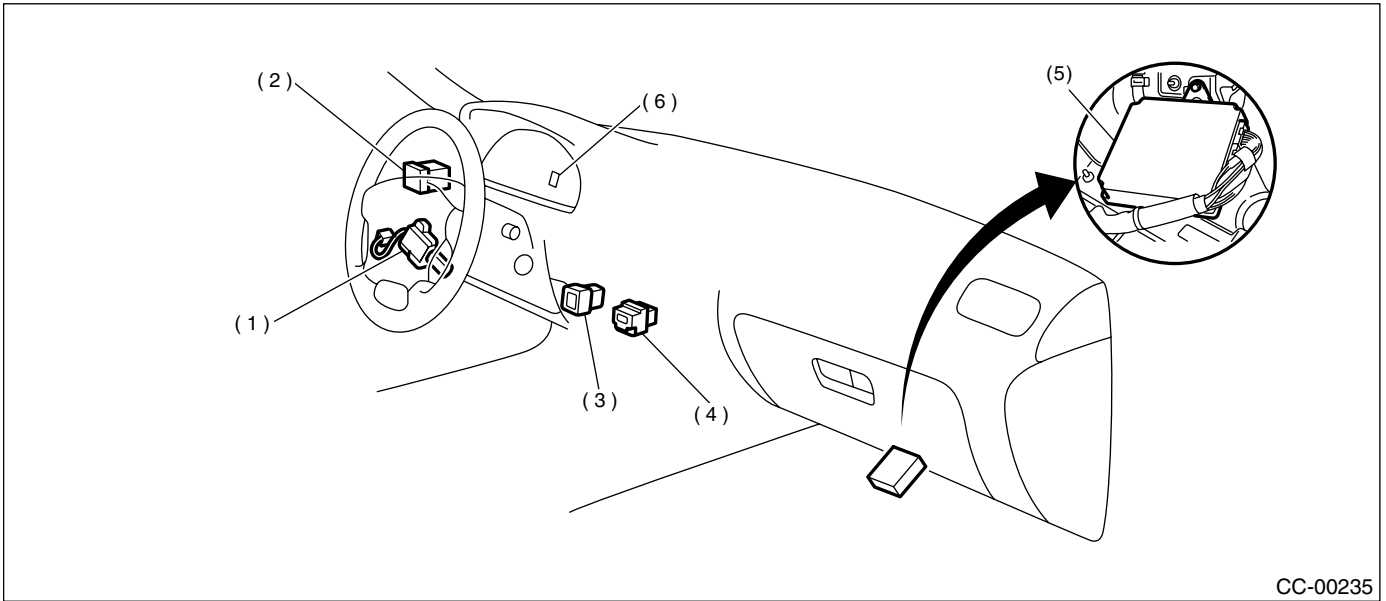

CC-00235

- (1) Cruise control command switch
- (2) Cruise control main switch

- (3) Clutch switch (MT)
- (4) Stop and brake switch

- (5) Engine control module
- (6) Cruise set indicator light

2. MODEL WITHOUT ELECTRONIC CONTROL THROTTLE

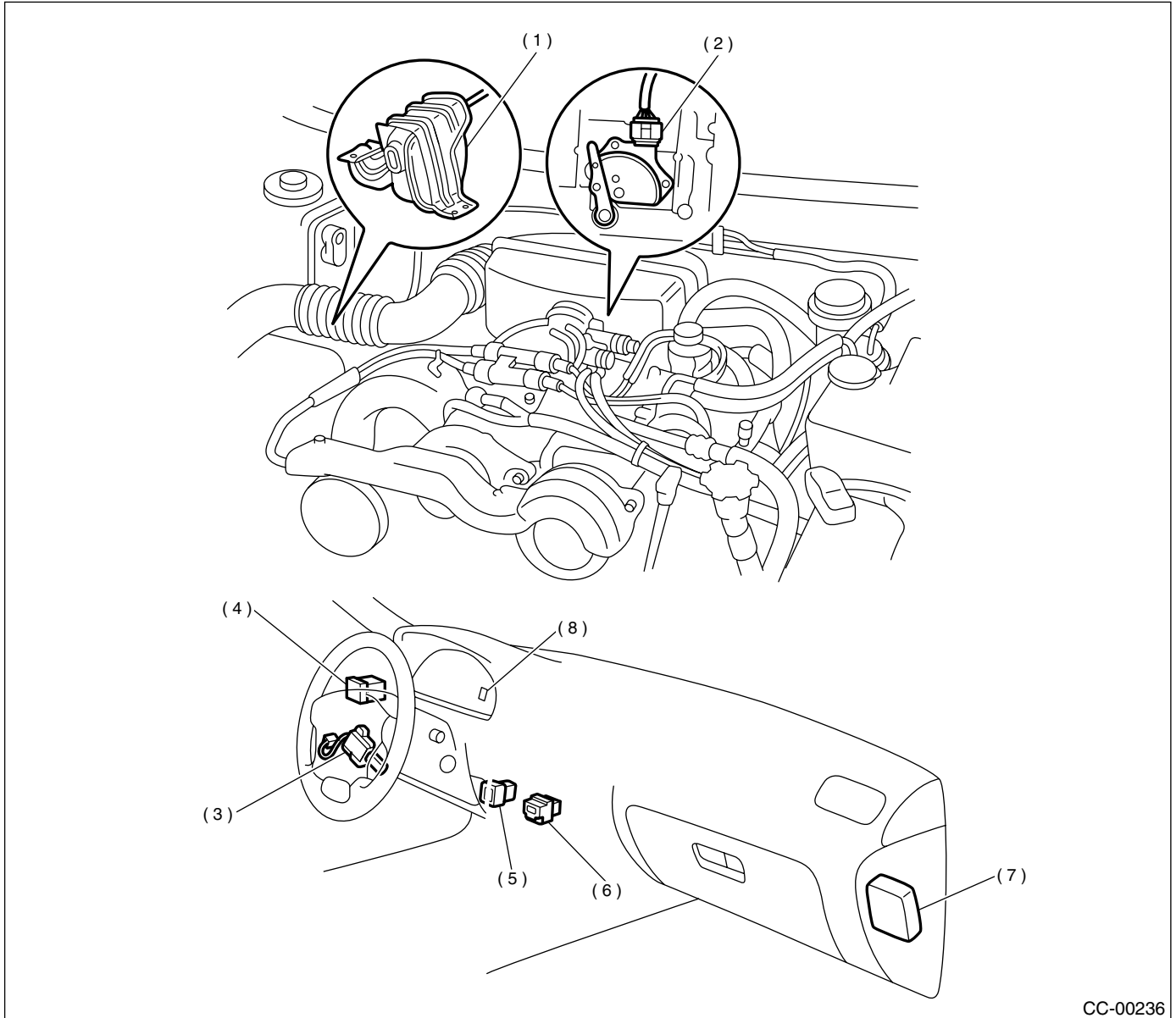

- | | | |
|-----------------------------------|--------------------------------|--------------------------------|
| (1) Actuator | (4) Cruise control main switch | (7) Cruise control module |
| (2) Inhibitor switch (AT) | (5) Clutch switch (MT) | (8) Cruise set indicator light |
| (3) Cruise control command switch | (6) Stop and brake switch | |

GENERAL DESCRIPTION

CRUISE CONTROL SYSTEM

B: CAUTION

- Before disassembling or reassembling parts, always disconnect the battery ground cable. When repairing the radio, control module and other parts with memory functions, make note of the memory before disconnecting the battery ground cable. All memory will be erased.
- Reassemble parts in the reverse order of disassembly unless otherwise indicated.
- Adjust parts to specifications specified in this manual.
- Connect connectors and hoses securely during reassembly.
- After reassembly, ensure functional parts operate properly.

C: PREPARATION TOOL

TOOL NAME	REMARKS
Circuit tester	Used for measuring resistance and voltage.

2. Actuator

A: REMOVAL

CAUTION:

- Be careful not to apply excessive load to the wire cable when adjusting and/or installing; otherwise, the actuator may be deformed or damaged.
- Do not bend cable sharply with a radius less than 100 mm (3.94 in); otherwise, cable may bend permanently, resulting in poor performance.
- When installing cable, be careful not to sharply bend or pinch the inner cable; otherwise, the cable may break.

- 1) Disconnect ground cable from battery.
- 2) Remove clip bands from cruise control cable.
- 3) Loosen nut which secures cruise control cable end to throttle cam and then remove cable from throttle cam.

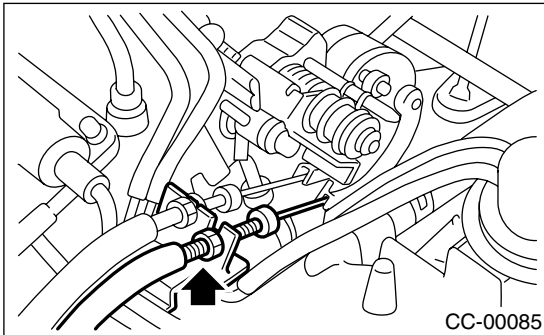

- 4) Remove actuator attaching bolts.
- 5) Remove actuator while disconnecting connector.

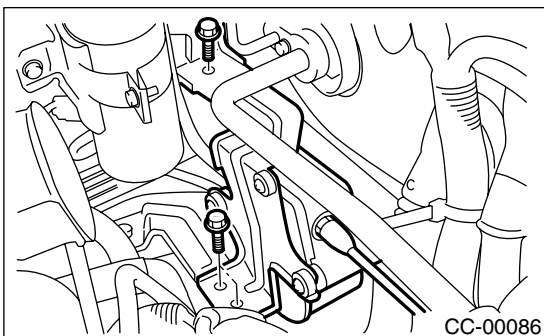

B: INSTALLATION

Install in the reverse order of removal.

Tightening torque:

Actuator

7.4 N·m (0.75 kgf·m, 5.4 ft·lb)

Cable end nut

12 N·m (1,2 kgf·m, 8.7 ft·lb)

NOTE:

(A): Must be adjusted when cable end outer is fixed in place, so that gap between throttle cam and lever is 0 — 1 mm (0 — 0.04 in), or inner cable deflection (D) is 1 — 8 mm (0.039 — 0.315 in) with specified range of throttle cable play.

(Must be attached while throttle cam is being pulled by wire cable.)

(B): Must be coated evenly on cam end inner connection.

(C): Cover must be inserted securely, until tip of cable touches cover stopper.

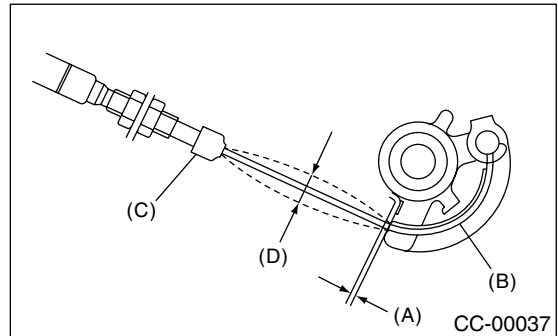

C: INSPECTION

Measure cruise control actuator resistance.

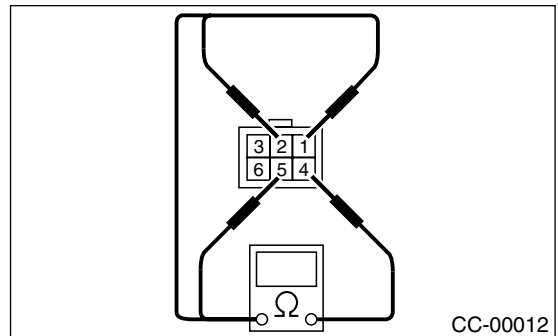

Terminal No.	Standard
4 and 1	Approx. 5Ω
4 and 2	Approx. 5Ω
4 and 5	Approx. 5Ω
3 and 6	Approx. 39Ω

If NG, replace cruise control actuator.

3. Cruise Control Module

A: NOTE

1. MODEL WITH ELECTRONIC CONTROL THROTTLE

Cruise control system is controlled by Engine Control Module (ECM).

B: REMOVAL

1. MODEL WITHOUT ELECTRONIC CONTROL THROTTLE

- 1) Disconnect ground cable from battery.
- 2) Remove glove box. <Ref. to EI-42, REMOVAL, Glove Box.>
- 3) Remove nut, then remove cruise control module (A) and the other electrical control module (B) while disconnecting connector.

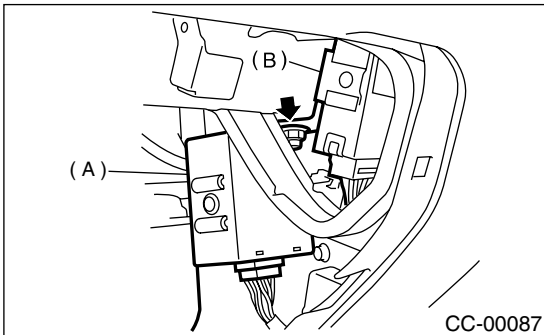

- 4) Disconnect cruise control module and the other electrical control module.

2. MODEL WITH ELECTRONIC CONTROL THROTTLE

<Ref. to FU(H4DOTC)-43, REMOVAL, Engine Control Module (ECM).> or <Ref. to FU(H4SO U5)-49, REMOVAL, Engine Control Module.>

C: INSTALLATION

1. MODEL WITHOUT ELECTRONIC CONTROL THROTTLE

Install is in the reverse order of removal.

2. MODEL WITH ELECTRONIC CONTROL THROTTLE

<Ref. to FU(H4DOTC)-43, INSTALLATION, Engine Control Module (ECM).> or <Ref. to FU(H4SO U5)-49, INSTALLATION, Engine Control Module.>

4. Cruise Control Main Switch

A: REMOVAL

- 1) Disconnect ground cable from battery.
- 2) Remove hook (B) and then remove switch panel (A) while disconnecting connector.

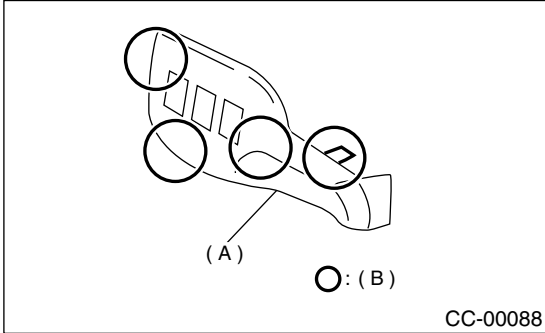

- 3) Remove main switch by pushing it outward.

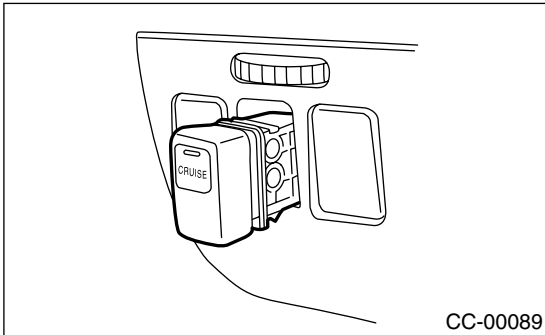

B: INSTALLATION

Install is in the reverse order of removal.

C: INSPECTION

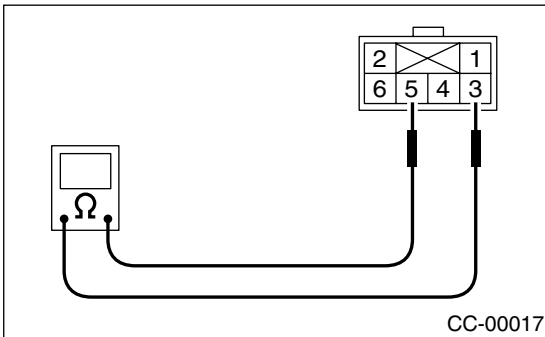

Switch position	Terminal No.	Standard
OFF (Released)	3 and 5	More than 1 MΩ
ON (Pushed)	3 and 5	Less than 1 Ω

If NG, replace cruise control main switch.

CRUISE CONTROL COMMAND SWITCH

CRUISE CONTROL SYSTEM

5. Cruise Control Command Switch

A: REMOVAL

WARNING:

Before servicing, be sure to read the notes in the AB section for proper handling of the driver's airbag module. <Ref. to AB-3, CAUTION, GENERAL DESCRIPTION.>

- 1) Set front wheels in straight ahead position.
- 2) Turn ignition switch OFF.
- 3) Disconnect ground cable from battery and wait for at least 20 seconds before starting work.
- 4) Using TORX® BIT T30 (Tamper resistant type), loosen two TORX® bolts which secure driver's airbag module.

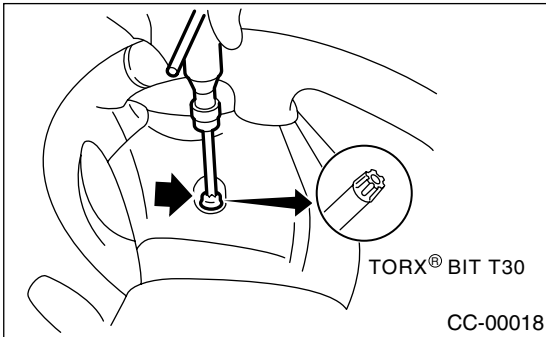

- 5) Disconnect airbag module connector on back of airbag module.
- 6) Remove horn switch from steering wheel as shown.

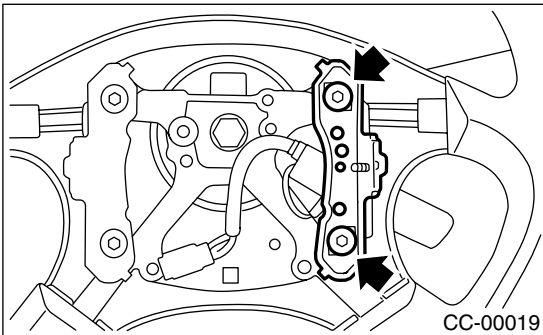

- 7) Disconnect horn and cruise control command switch connector, then remove cruise control command switch.

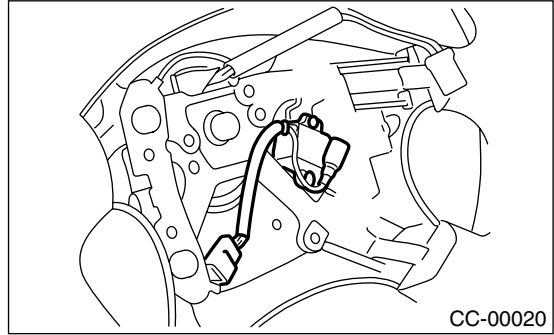

B: INSTALLATION

Install is in the reverse order of removal.

C: INSPECTION

Measure cruise control command switch resistance.

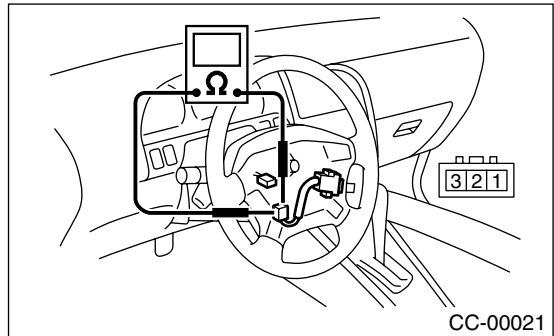

Check continuity between cruise control command switch terminals.

Switch	Position	Terminal No.	Standard
CANCEL	ON	1 (+) and 2 (-)	Less than 1 Ω
	ON	1 (+) and 3 (-)	Less than 1 Ω
SET/ COAST	OFF	1 and 2	More than 1 M Ω
	ON	1 and 2	Less than 1 Ω
RESUME/ ACCEL	OFF	1 and 3	More than 1 M Ω
	ON	1 and 3	Less than 1 Ω

If NG, replace cruise control command switch.

6. Stop and Brake Switch

A: REMOVAL

- 1) Disconnect ground cable from battery.
- 2) Disconnect connector from stop and brake switch, and then remove the switch. <Ref. to BR-42, REMOVAL, Stop Light Switch.>

B: INSTALLATION

Install in the reverse order of removal.

C: INSPECTION

Measure the brake switch (A) and stop light switch (B) resistance.

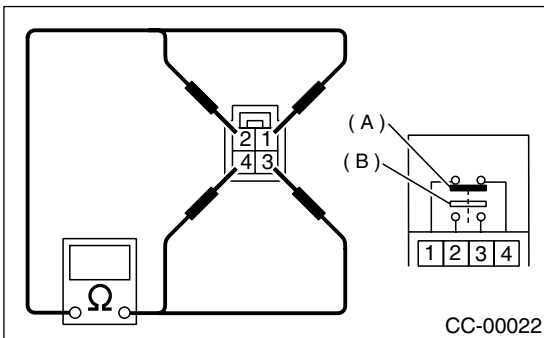

Switch	Pedal	Terminal No.	Standard
Brake	Released	1 and 4	Less than 1 Ω
	Depressed	1 and 4	More than 1 MΩ
Stop light	Released	2 and 3	More than 1 MΩ
	Depressed	2 and 3	Less than 1 Ω

If NG, replace stop and brake switch.

7. Clutch Switch

A: REMOVAL

- 1) Disconnect ground cable from battery.
- 2) Disconnect the connector from the clutch switch, and then remove the switch. <Ref. to CL-28, REMOVAL, Clutch Pedal.>

B: INSTALLATION

Install in the reverse order of removal.

C: INSPECTION

Measure clutch switch resistance.

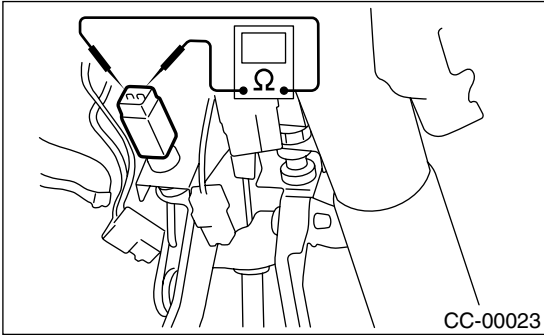

Switch	Pedal	Terminal No.	Standard
Clutch	Released	1 and 2	Less than 1 Ω
	Depressed	1 and 2	More than 1 M Ω

If NG, replace the clutch switch.

8. Inhibitor Switch

A: REMOVAL

- 1) Disconnect ground cable from battery.
- 2) Disconnect connector from inhibitor switch, and then remove the switch. <Ref. to 4AT-52, REMOVAL, Inhibitor Switch.>

B: INSTALLATION

Installation is in the reverse order of removal.

C: INSPECTION

Measure inhibitor switch resistance.

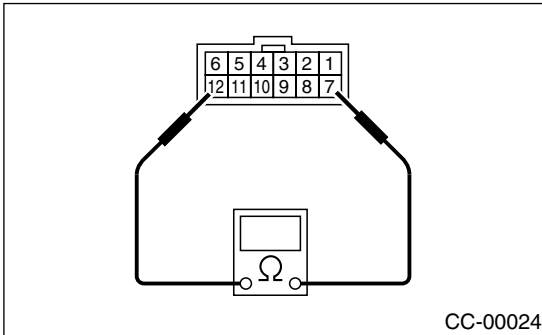

Selector lever position	Terminal No.	Standard
P	7 and 12	Less than 1 Ω
N		Less than 1 Ω
Except P and N		More than 1 MΩ

If NG, replace inhibitor switch.

INHIBITOR SWITCH

CRUISE CONTROL SYSTEM

MEMO: