

WIPER AND WASHER SYSTEMS



	Page
1. General Description	2
2. Wiper and Washer System	6
3. Combination Switch (Wiper).....	7
4. Wiper Blade.....	9
5. Washer Tank and Motor.....	10
6. Front Wiper Arm.....	11
7. Front Wiper Motor and Link.....	12
8. Front Washer Nozzle	13
9. Rear Wiper Arm	14
10. Rear Wiper Motor.....	15
11. Rear Washer Nozzle	16
12. Wiper Control Relay	17

GENERAL DESCRIPTION

WIPER AND WASHER SYSTEMS

1. General Description

A: SPECIFICATIONS

Front wiper motor	Input	12 V — 72 W or less
Rear wiper motor	Input	12 V — 42 W or less
Front washer motor	Pump type	Centrifugal
	Input	12 V — 36 W or less
Rear washer motor	Pump type	Centrifugal
	Input	12 V — 36 W or less

B: COMPONENT

1. FRONT WIPER

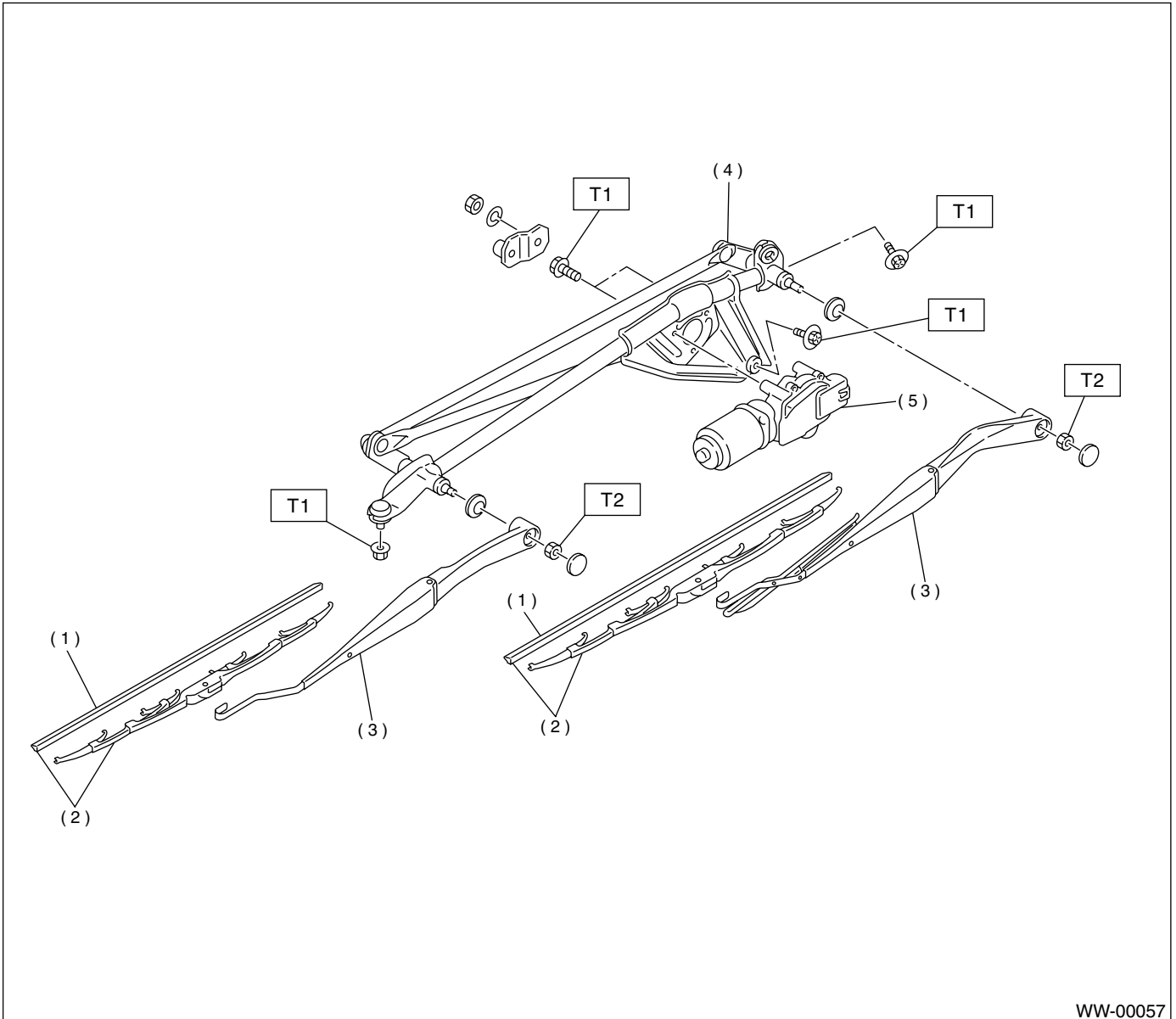

WW-00057

- (1) Wiper rubber
- (2) Wiper blade ASSY
- (3) Wiper arm

- (4) Wiper link
- (5) Wiper motor

Tightening torque: N-m (kgf-m, ft-lb)

T1: 6.0 (0.61, 4.4)

T2: 20 (2.0, 14.5)

GENERAL DESCRIPTION

WIPER AND WASHER SYSTEMS

2. REAR WIPER

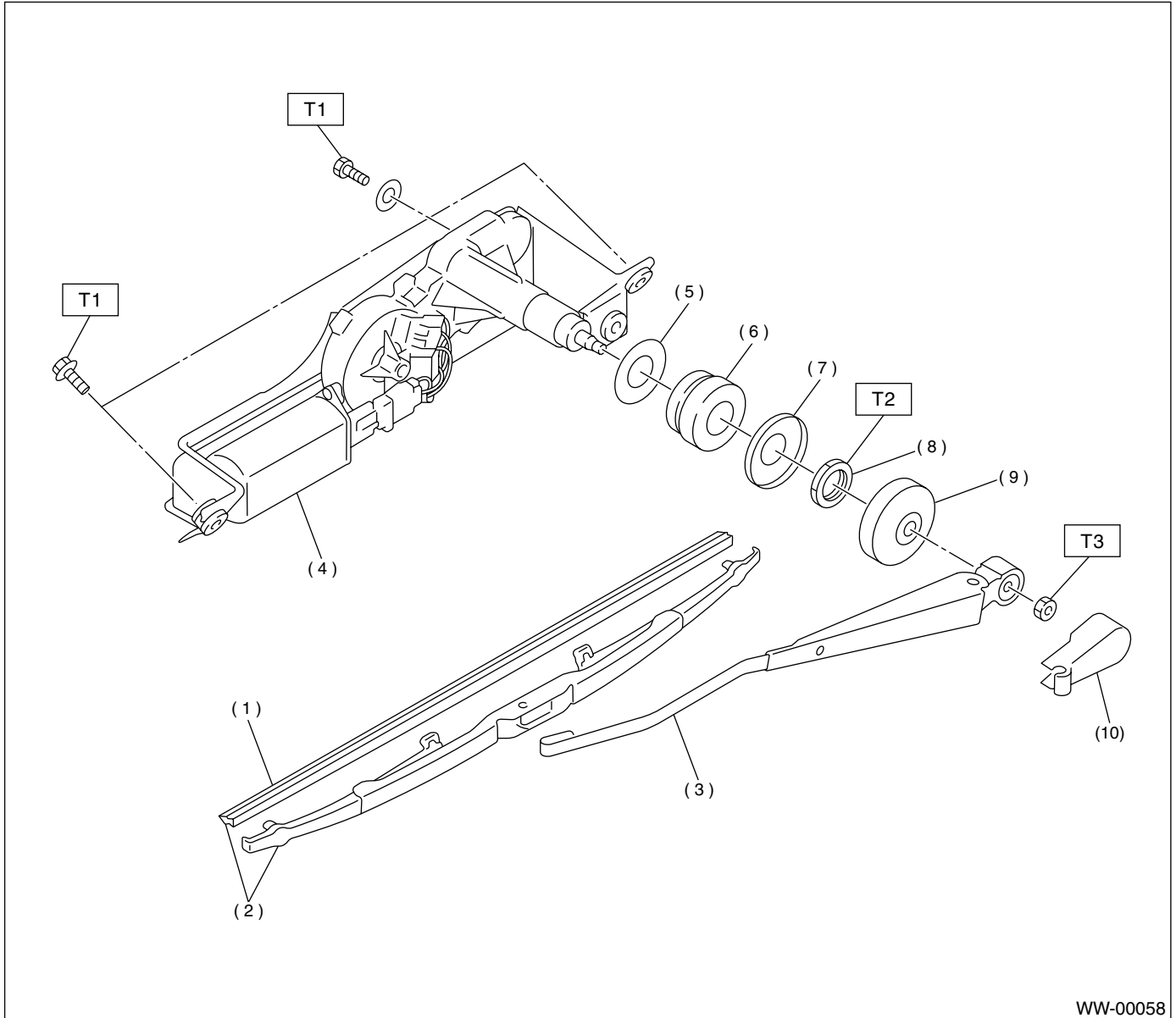

- | | |
|----------------------|----------------------|
| (1) Wiper rubber | (6) Cushion |
| (2) Wiper blade ASSY | (7) Spacer B |
| (3) Wiper arm | (8) Nut |
| (4) Wiper motor | (9) Cap |
| (5) Spacer A | (10) Wiper arm cover |

Tightening torque: N·m (kgf-m, ft-lb)

T1: 5.9 (0.6, 4.3)

T2: 7.4 (0.75, 5.4)

T3: 7.8 (0.8, 5.8)

GENERAL DESCRIPTION

WIPER AND WASHER SYSTEMS

3. WASHER TANK

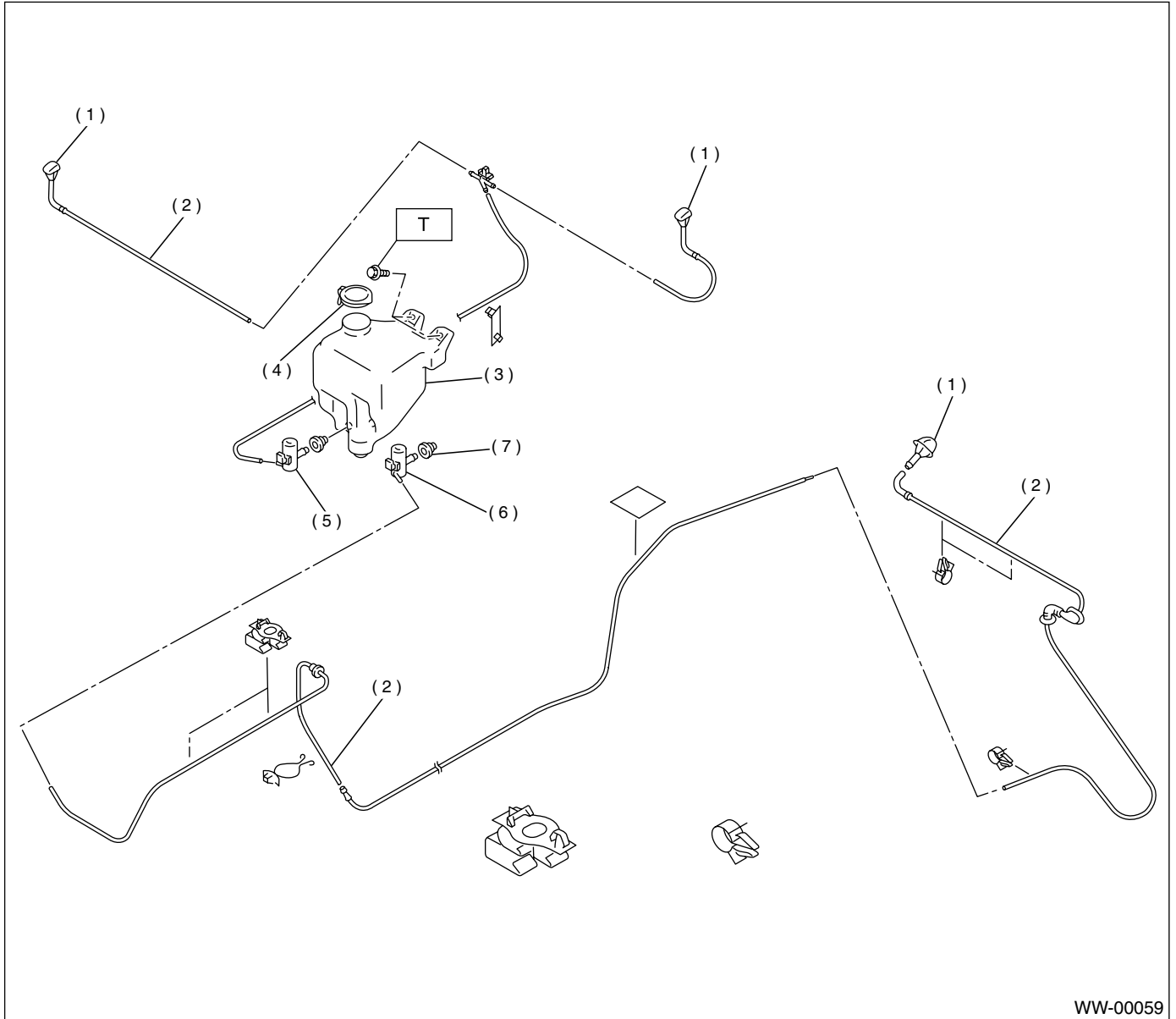

- (1) Washer nozzle
- (2) Washer hose
- (3) Washer tank
- (4) Washer tank cap

- (5) Front washer motor
- (6) Rear washer motor
- (7) Grommet

Tightening torque: N·m (kgf-m, ft-lb)
T: 5.9 (0.6, 4.3)

C: CAUTION

- Reconnect connectors and hoses securely. After reconnecting, confirm that each function operates normally.
- Be careful that wire harnesses of airbag system pass near electrical parts and switches.
- Wire harnesses and connectors of all airbag system are yellow color. Do not use a tester on these circuits.
- Care must be taken when installing the piping hose so that no bending, jamming, etc. are caused.
- If even a little oil or grease such as silicon oil gets in the tank and washer passages, an oil film easily forms on the glass, causing the wiper to chatter and judder. Therefore, be careful not to let this happen.

WIPER AND WASHER SYSTEM

WIPER AND WASHER SYSTEMS

2. Wiper and Washer System

A: SCHEMATIC

1. WIPER AND WASHER (FRONT)

<Ref. to WI-296, Wiper and Washer System (Front).>

2. WIPER AND WASHER (REAR)

<Ref. to WI-297, Wiper and Washer System (Rear).>

B: INSPECTION

Symptom	Repair order
Wiper and washers do not operate.	(1) Wiper fuse (F/B No. 14, 15) (2) Combination switch (3) Wiper motor (4) Wiring harness
Wipers do not operate in LO or HI.	(1) Combination switch (2) Wiper motor (3) Wiring harness
Wipers do not operate in INT.	(1) Combination switch (2) Wiper motor (3) Wiring harness
Washer motor does not operate.	(1) Washer switch (2) Washer motor (3) Wiring harness
Wipers do not operate when washer switch is ON.	(1) Washer motor (2) Wiring harness
Washer fluid spray does not spurt normally.	(1) Washer motor (2) Washer hose and nozzle

COMBINATION SWITCH (WIPER)

WIPER AND WASHER SYSTEMS

3. Combination Switch (Wiper)

A: REMOVAL

1) Remove screw to remove a steering column cover.

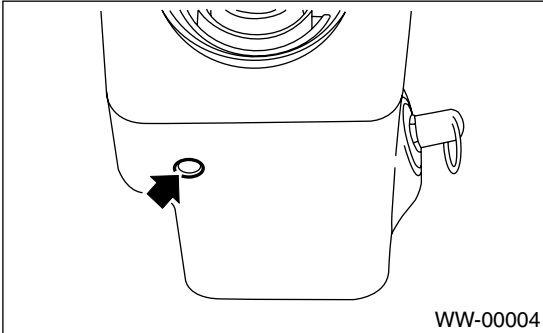

2) Disconnect harness connectors from combination switches.

3) Remove screw to remove combination switch.

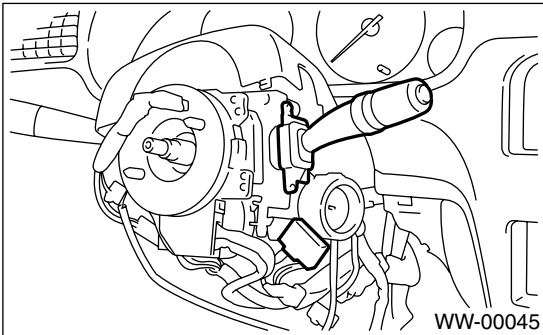

B: INSTALLATION

Install in the reverse order of removal.

C: INSPECTION

• Inspect the continuity between each connector terminal.

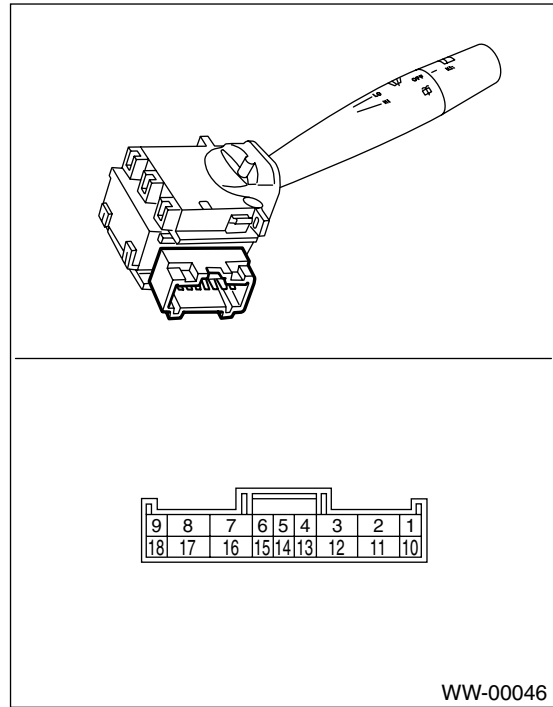

	Switch position	Terminal No.	Standard
FRONT	OFF	7 and 16 7 and 17 8 and 17 2 and 11	More than 1 Ω
	INT	7 and 16	Less than 1 Ω
	LO	7 and 17	Less than 1 Ω
	HI	8 and 17	Less than 1 Ω
REAR	Washer ON	2 and 10 10 and 12 2 and 12	Less than 1 Ω
	OFF	2 and 10 10 and 12 2 and 12	More than 1 MΩ
	ON	2 and 10	Less than 1 Ω
	Washer ON	2 and 10 10 and 12 2 and 12	Less than 1 Ω

If continuity is not as specified, replace the switch.

COMBINATION SWITCH (WIPER)

WIPER AND WASHER SYSTEMS

- Intermittent operation inspection

1) Turn the wiper switch to INT.

2) Adjust the intermittent control switch to MAX.

3) Apply battery voltage to switch terminals 17 and 2, and inspect the voltage of terminals 7 and 2. (Measure the voltage from after the second time the wiper stops.)

(A)	(B)
(C)	
(D)	
(E)	

WW-00053

(A) Switch position

(B) Voltage

(C) MIN.

(D) MAX.

(E) Non-variable

(F) 12 V

(G) 0 V

(H) Approx. 2 sec.

(I) 16 ± 6 sec.

(J) 3 ± 1 sec.

If operation is not as specified, replace the switch.

4. Wiper Blade

A: REMOVAL

While pushing locking clip (A) up, pull out blade from arm to arrow direction.

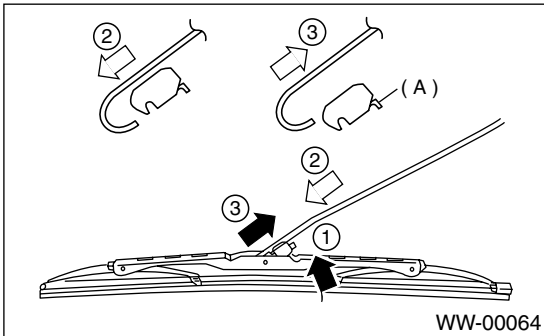

B: INSTALLATION

- 1) Install in the reverse order of removal.
- 2) Confirm that clip was locked securely.

C: DISASSEMBLY

Pull on side (A) of the wiper rubber stopper and remove the rubber from the blade assembly.

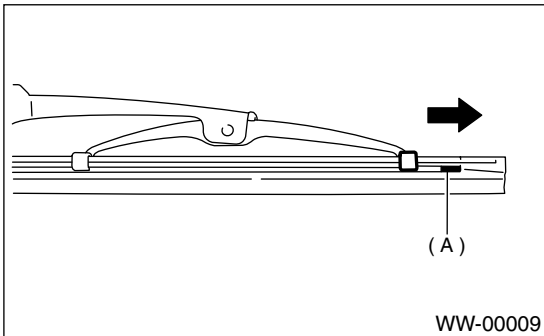

D: ASSEMBLY

- 1) Insert the wiper rubber onto the blade so that the stopper is in the position shown (at the bottom of the wiper arm).

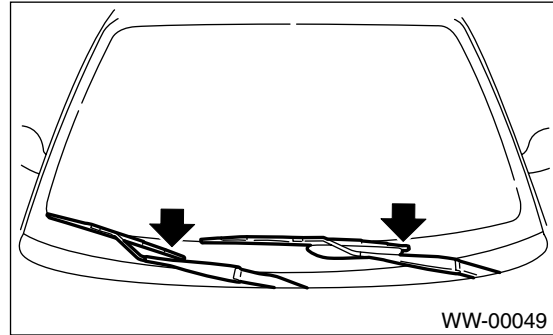

- 2) Make sure the wiper rubber is securely fastened to the pull stopper (A).

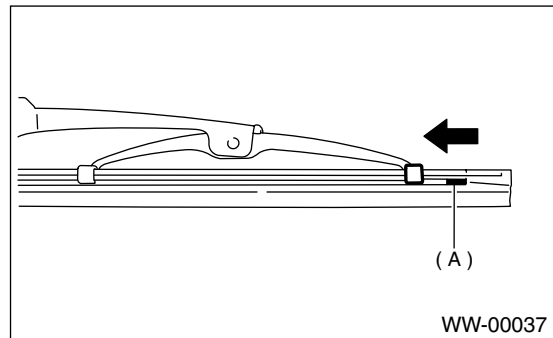

E: INSPECTION

- 1) When the wiper does not perform well, inspect the following:
 - Make sure the movable part of the blade assembly moves smoothly.
 - Make sure the wiper rubber is not deformed or damaged.
- 2) Replace with a new part if damage is found.

WASHER TANK AND MOTOR

WIPER AND WASHER SYSTEMS

5. Washer Tank and Motor

A: REMOVAL

- 1) Open front hood.
- 2) Remove the 2 bolts, hose and connector and then remove the tank.

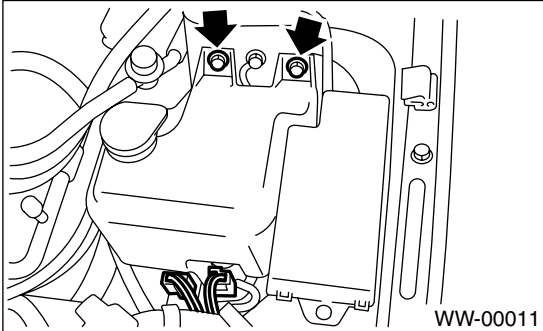

B: INSTALLATION

Install in the reverse order of removal.

Tightening torque:

5.9 N·m (0.6 kgf·m, 4.3 ft·lb)

C: DISASSEMBLY

Remove washer motor from tank.

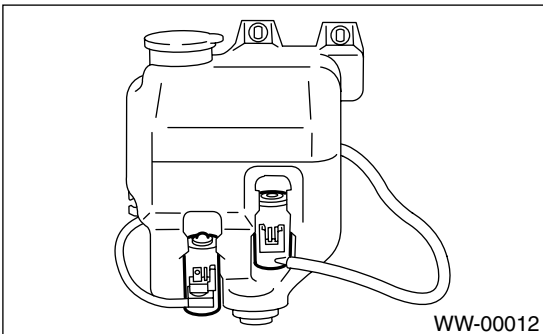

D: ASSEMBLY

- 1) Assemble in the reverse order of disassembly.
- 2) Confirm that water does not leak from installation area of motor.

E: INSPECTION

Apply battery voltage to the connector terminal of the washer motor and make sure the motor operates.

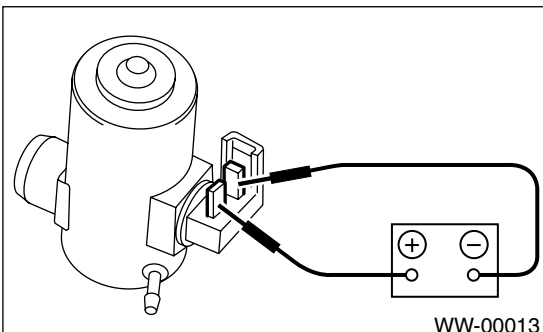

6. Front Wiper Arm

A: REMOVAL

- 1) Open front hood.
- 2) Remove cap.
- 3) Remove nut to remove arm.

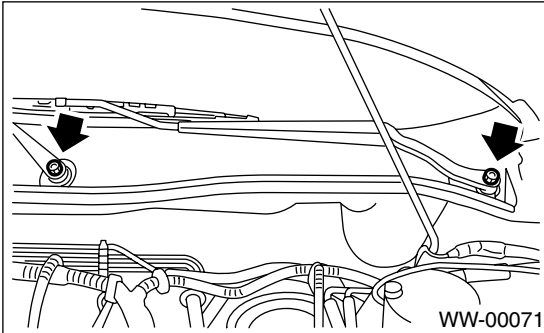

B: INSTALLATION

- 1) Install in the reverse order of removal.
- 2) Operate wiper once.
- 3) Align wiper blade to ceramic print point mark (A) of front window pane.

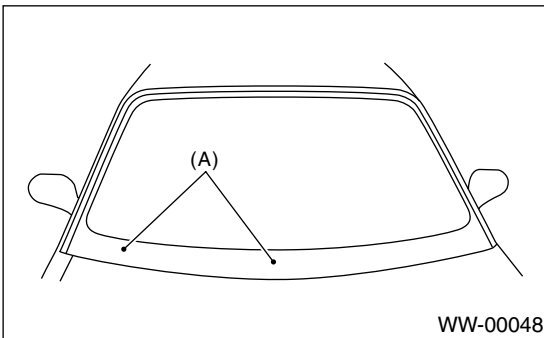

Tightening torque:

Refer to COMPONENT in General Description. <Ref. to WW-2, FRONT WIPER, COMPONENT, General Description.>

C: ADJUSTMENT

Operate wiper once. Align wiper blade to ceramic print point mark (A) of front window pane.

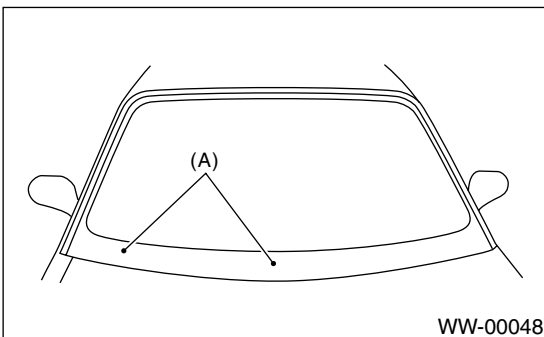

FRONT WIPER MOTOR AND LINK

WIPER AND WASHER SYSTEMS

7. Front Wiper Motor and Link

A: REMOVAL

- 1) Disconnect ground cable from battery.
- 2) Remove cowl panel. <Ref. to EI-35, REMOVAL, Cowl Panel.>
- 3) Disconnect connector of motor.
- 4) Remove bolts and nuts to remove wiper link.

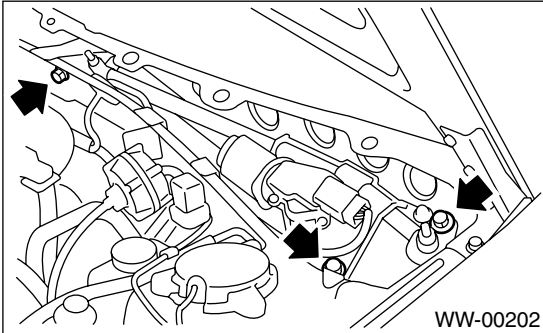

- 5) Remove bolts and nuts to remove motor.

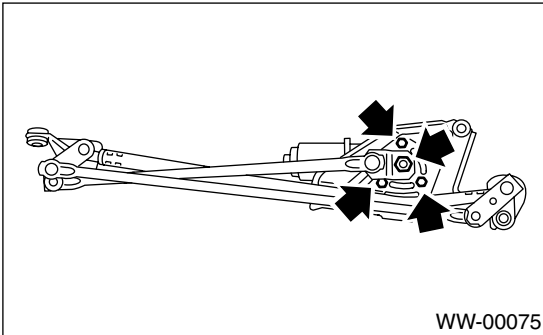

B: INSTALLATION

Install in the reverse order of removal.

Tightening torque:

Refer to **COMPONENT** in *General Description*. <Ref. to WW-2, FRONT WIPER, COMPONENT, General Description.>

C: INSPECTION

- 1) When battery is connected to terminal of connectors, confirm that motor operates at low speed.

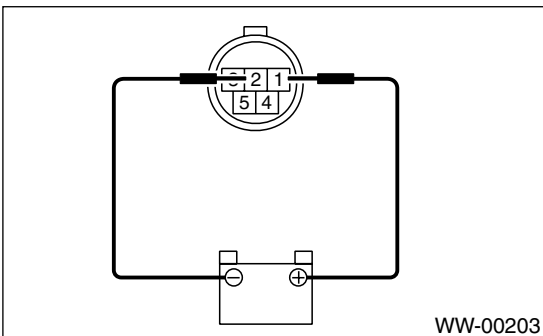

- 2) When battery is connected to terminal of connectors, confirm that motor operates at high speed.

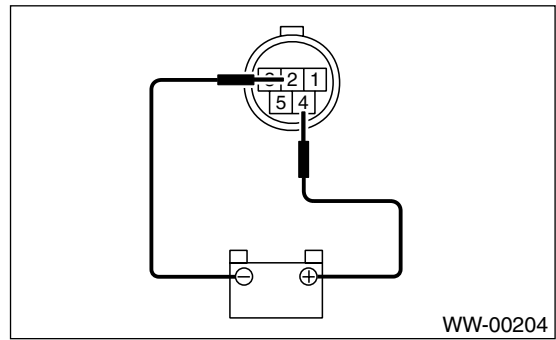

- 3) Connect battery to terminals of connector, and remove terminal connection with motor rotated at low speed, and stop wiper motor through operation.

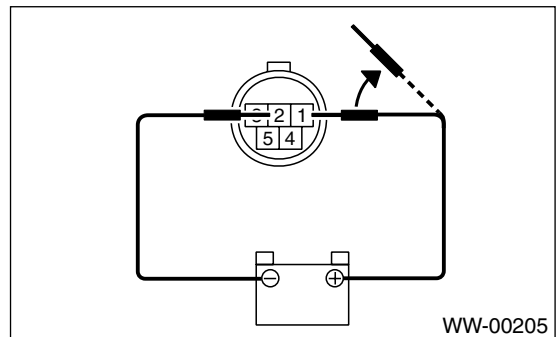

- 4) Connect battery and confirm that motor stops at automatic stop position after motor operates at low speed again.

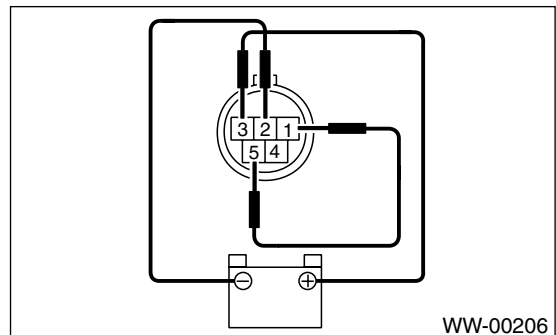

8. Front Washer Nozzle

A: REMOVAL

- 1) Remove the washer hose from the washer nozzle.
- 2) Open the clips on the underside of the front hood with a thin screwdriver or other tool, and remove the washer nozzle.

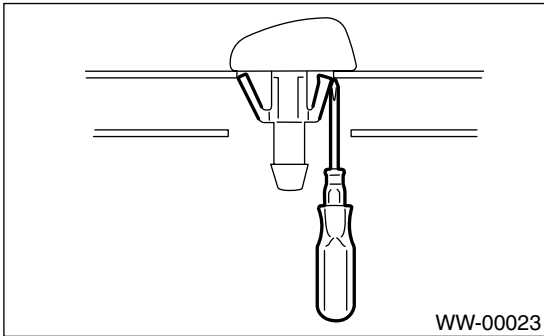

B: INSTALLATION

- 1) Install in the reverse order of removal.
- 2) Adjust the position of the washer liquid sprayer. <Ref. to WW-13, ADJUSTMENT, Front Washer Nozzle.>

C: INSPECTION

- Make sure the nozzle and hose are not clogged.
- Make sure the hose is not bent.

D: ADJUSTMENT

- 1) Turn wiper switch to OFF position.
- 2) When vehicle stops, adjust washer injection position as shown in the figure.

Injection position:

A: 300 mm (11.81 in)

B: 100 mm (3.94 in)

C: 200 mm (7.87 in)

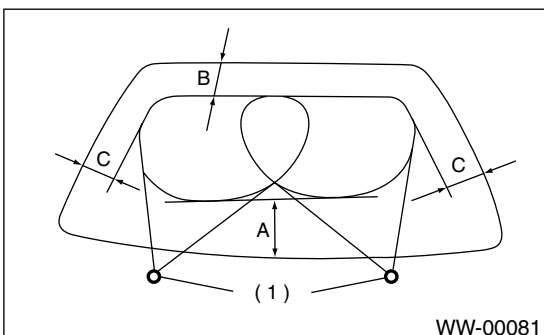

(1) Nozzle

9. Rear Wiper Arm

A: REMOVAL

- 1) Raise wiper arm cover (A).
- 2) Remove nut to remove wiper arm.

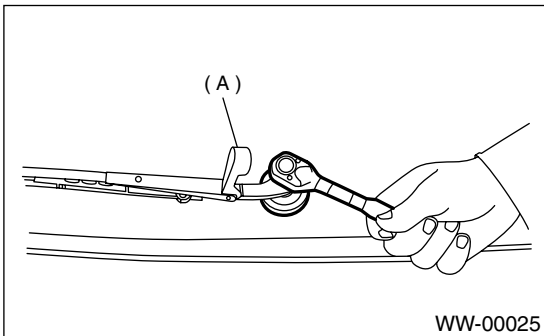

B: INSTALLATION

- 1) Install in the reverse order of removal.
- 2) Operate rear wiper once.
- 3) Align blade to rear defogger heat wire (A).

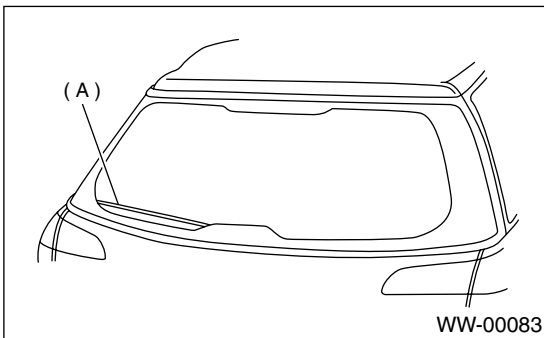

Tightening torque:

Refer to COMPONENT in General Description. <Ref. to WW-2, FRONT WIPER, COMPONENT, GENERAL DESCRIPTION.>

C: ADJUSTMENT

- 1) Operate rear wiper once.
- 2) Align blade to rear defogger heat wire (A).

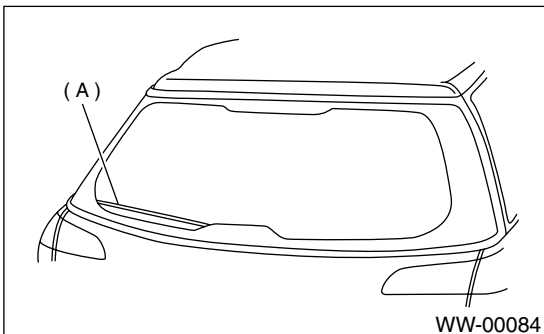

10. Rear Wiper Motor

A: REMOVAL

- 1) Disconnect ground cable from battery.
- 2) Remove rear wiper arm.
- 3) Remove cap (A), nut (B), and spacer (C) from rear wiper shaft.

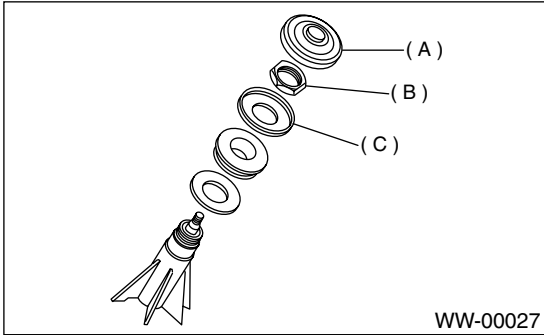

- 4) Remove rear gate lower trim. <Ref. to EI-57, REMOVAL, Rear Gate Trim.>
- 5) Unclip clip of harness and disconnect connector of wiper motor.
- 6) Remove bolts to remove wiper motor assembly (A).

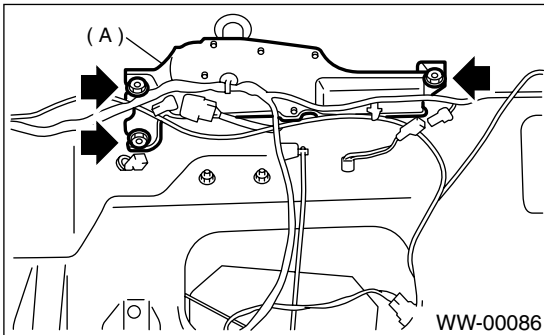

B: INSTALLATION

- 1) Install in the reverse order of removal.
- 2) Install rear wiper cushion with the arrow mark facing up, as shown in the figure.

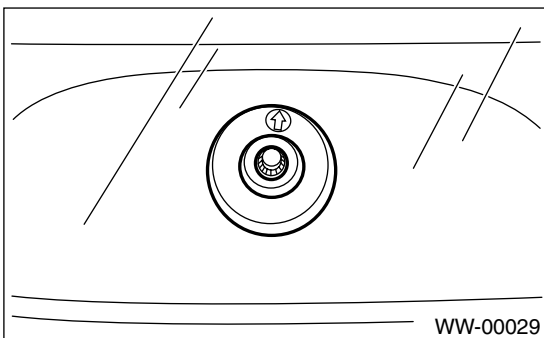

Tightening torque:

Refer to **COMPONENT** in *General Description*. <Ref. to WW-2, **FRONT WIPER, COMPONENT, General Description**.>

C: INSPECTION

- 1) Connect battery to wiper motor connector and confirm that wiper motor operates.

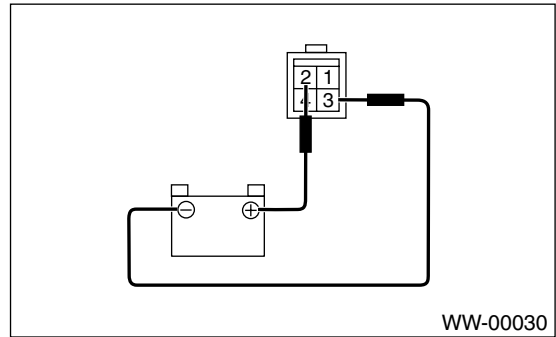

- 2) Connect battery to terminal of connector and remove terminal connections with motor rotated, and stop wiper motor through operation.

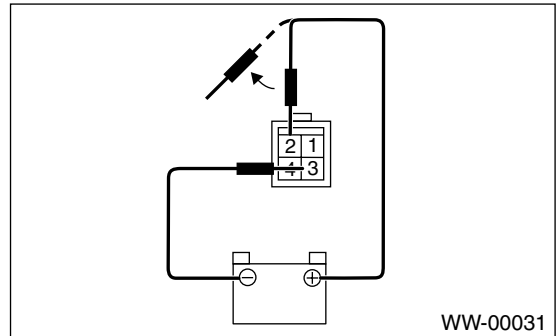

- 3) Connect battery and confirm that motor stops at automatic stop position after motor operates at low speed again.

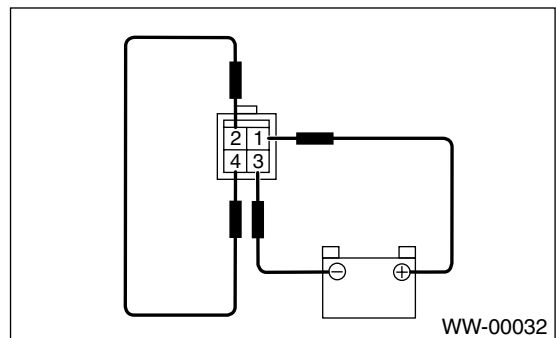

11.Rear Washer Nozzle

A: REMOVAL

- 1) Remove the high-mount stop light. <Ref. to LI-27, REMOVAL, High-mounted Stop Light.>
- 2) Remove the washer hose from the washer nozzle.
- 3) Open the clips on the underside of the rear gate with a thin screwdriver or other tool, and remove the washer nozzle.

B: INSTALLATION

- 1) Install in the reverse order of removal.
- 2) Adjust the position of the washer liquid sprayer. <Ref. to WW-16, ADJUSTMENT, Rear Washer Nozzle.>

C: INSPECTION

- Make sure the nozzle and hose are not clogged.
- Make sure the hose is not bent.

D: ADJUSTMENT

- 1) Turn wiper switch to OFF position.
- 2) When vehicle stops, adjust washer injection position as shown in the figure.

Injection position:

A: 60 mm (2.36 in)

B: 42°

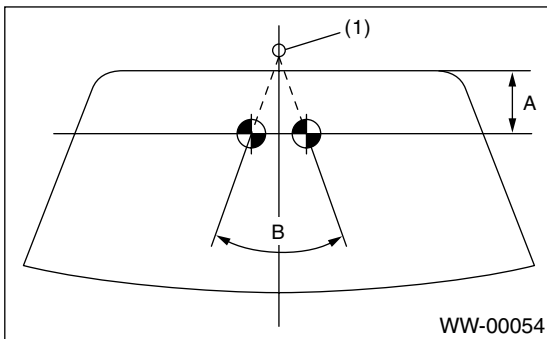

(1) Nozzle

12. Wiper Control Relay

A: REMOVAL

1. WAGON

- 1) Remove right quarter lower trim. <Ref. to EI-52, REMOVAL, Rear Quarter Trim.>
- 2) Remove quarter pocket.
- 3) Remove nut to remove wiper control relay.

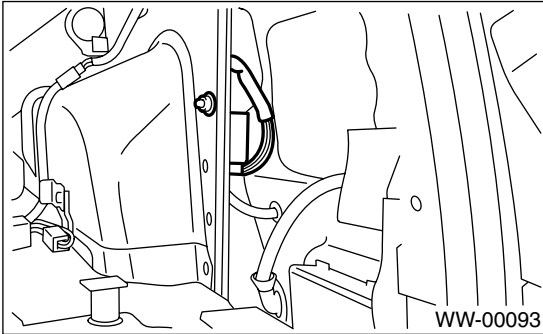

B: INSTALLATION

1. WAGON

Install in the reverse order of removal.

C: INSPECTION

1. WAGON

- 1) Apply battery voltage to the rear terminals 8 and 2, and then inspect the voltage of 6 and 2. (Measure the voltage from after the second time the wiper stops.)

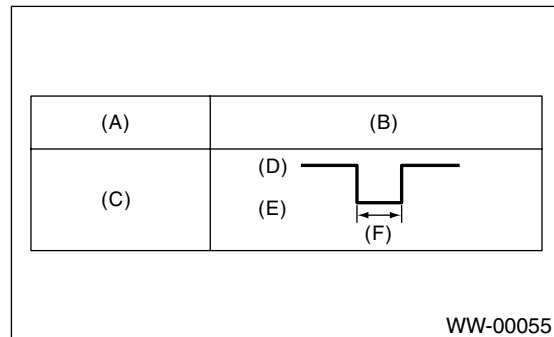
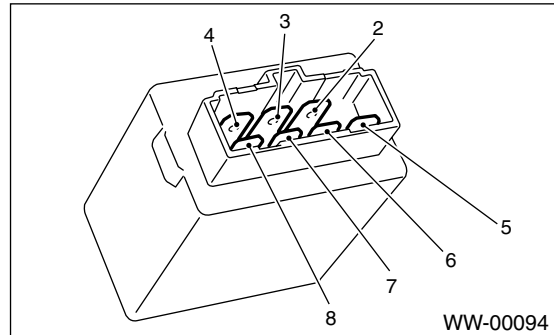

- (A) Switch position
- (B) Voltage
- (C) ON
- (D) 12 V
- (E) 0 V
- (F) 9 ± 2 sec.

If operation is not as specified, replace the switch.

WIPER CONTROL RELAY

WIPER AND WASHER SYSTEMS

MEMO: