

# COMMUNICATION SYSTEM

# COM

---

	<b>Page</b>
1. General Description .....	2
2. Horn System .....	3
3. Horn .....	4
4. Horn Switch.....	5



# GENERAL DESCRIPTION

COMMUNICATION SYSTEM

---

## 1. General Description

### A: CAUTION

- Before disassembling or reassembling parts, always disconnect the battery ground cable. When replacing radio, control module, and other parts provided with memory functions, record memory contents before disconnecting the battery ground cable. Otherwise, the memory will be erased.
- Reassemble in reverse order of disassembly, unless otherwise indicated.
- Adjust parts to the given specifications.
- Connect the connectors and hoses securely during reassembly.
- After reassembly, make sure functional parts operate smoothly.

### B: PREPARATION TOOL

#### 1. GENERAL TOOLS

TOOL NAME	REMARKS
Circuit Tester	Used for measuring resistance and voltage.

## 2. Horn System

### A: SCHEMATIC

#### 1. HORN

<Ref. to WI-209, SCHEMATIC, Horn System.>

### B: INSPECTION

#### 1. HORN RELAY

Measure horn relay resistance between terminals (indicated in table below) while connecting terminal No. 4 to battery positive terminal and terminal No. 3 to battery ground terminal.

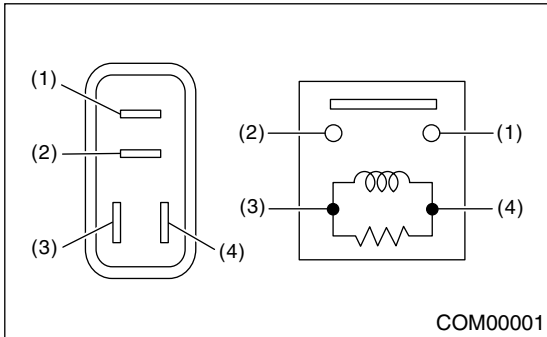

Current	Terminal No.	Standard
Flow	1 and 2	Less than 1 Ω
No flow		More than 1 MΩ

### 3. Horn

#### A: REMOVAL

- 1) Disconnect ground cable from battery.
- 2) Remove horn bracket mounting bolt (A).
- 3) Disconnect harness connector and remove horn assembly (B).

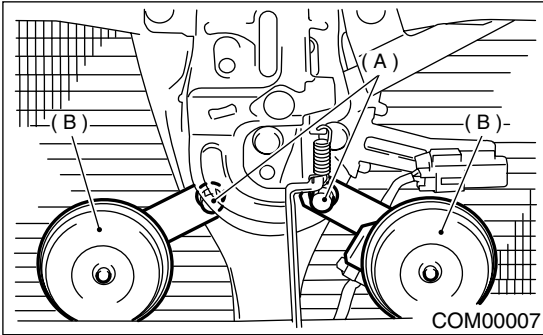

#### B: INSTALLATION

Install in the reverse order of removal.

#### C: INSPECTION

With 12 V direct current supply between horn terminal and case ground, check that the horn sounds properly.

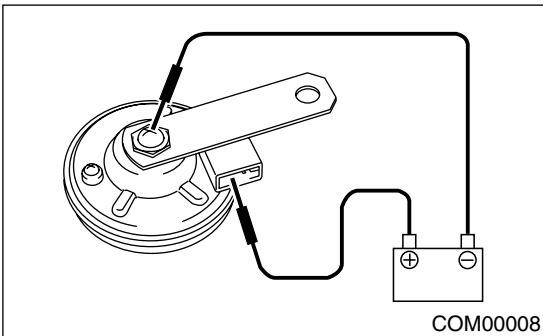

## 4. Horn Switch

### A: REMOVAL

**WARNING:**

Before servicing, be sure to read the notes in the AB section for proper handling of the driver airbag module. <Ref. to AB-3, CAUTION, General Description.>

- 1) Disconnect negative cable from battery.
- 2) Remove the driver's airbag module. <Ref. to AB-13, Driver's Airbag Module.>
- 3) Remove horn switch from steering wheel.

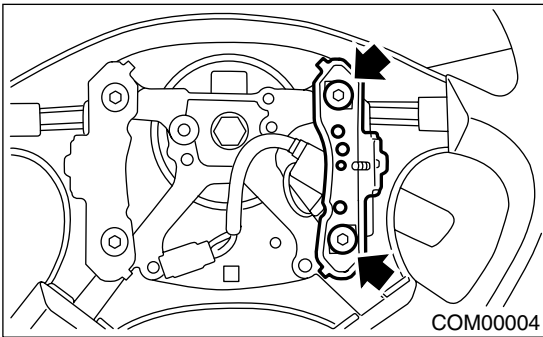

### B: INSTALLATION

Install in the reverse order of removal.

### C: INSPECTION

Measure horn switch resistance.

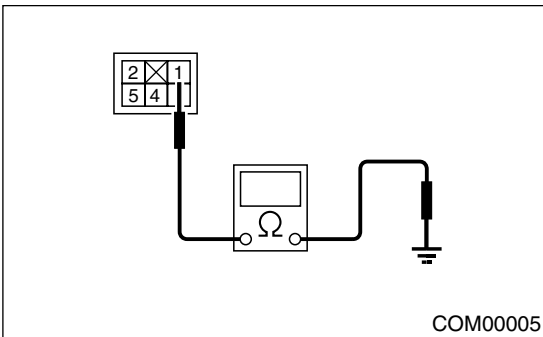

Switch position	Terminal No.	Standard
When horn switch is pushed.	1 and Body ground	Less than 1 Ω
When horn switch is not pushed.		More than 1 MΩ

# HORN SWITCH

COMMUNICATION SYSTEM

---

**MEMO:**