

### 1. Precaution

#### A: CAUTION

Please clearly understand and adhere to the following general precautions. They must be strictly followed to avoid minor or serious injury to the person doing the work or people in the area.

#### 1. ABS

Handle the ABS as a total system. Do not disassemble or attempt to repair parts which are not instructed in this manual. Follow the directions in this manual when performing maintenance on the ABS/SCM&H/U. When parts other than those specified are disassembled, it is possible that the ABS system will not operate when needed or cause it to operate incorrectly and result in injury.

#### 2. VEHICLE DYNAMICS CONTROL (VDC)

Handle the VDC as a total system. Do not disassemble or attempt to repair individual parts. Doing so could prevent the VDC system from operating when needed or cause it to operate incorrectly and result in injury.

#### 3. BRAKE FLUID

If brake fluid gets in your eyes or on your skin, do the following:

- Wash eyes and seek immediate medical attention.
- Wash your skin with soap and then rinse thoroughly with water.

#### 4. RADIATOR FAN

The radiator fan may rotate without warning, even when the engine is not ON. Do not place your hand, cloth, tools or other items near the fan at any time.

#### 5. ROAD TEST

Always conduct road tests in accordance with traffic rules and regulations to avoid bodily injury and interrupting traffic.

#### 6. AIRBAG

To prevent bodily injury from unexpected deployment of airbags and unnecessary maintenance, follow the instructions in this manual when performing maintenance on or near the airbag components, around front of the vehicle (radiator panel, front wheel apron, front side frame, front bumper, front hood, front fender), around side of the vehicle (front door, rear door, center pillar, rear fender, side sill, rear wheel apron), and on or near the airbag wiring harnesses.

To prevent unexpected deployment, turn the ignition switch to OFF and disconnect the ground cable from battery, then wait at least 20 seconds before starting work.

#### 7. AIRBAG AND SEAT BELT PRETENSIONER DISPOSAL

To prevent bodily injury from unexpected airbag deployment, do not dispose the airbag modules and seat belt pretensioner in the same way as other waste. Follow all government regulations concerning disposal of refuse.

#### 8. AIRBAG MODULE

Adhere to the following when handling and storing the airbag module to prevent bodily injury from unexpected deployment:

- Do not hold the harnesses or connectors to carry the module.
- Do not face the bag in the direction that it opens towards yourself or other people.
- Do not face the bag in the direction that it opens towards the floor or walls.

#### 9. AIRBAG SPECIAL TOOL

To prevent unexpected deployment, only use special tools.

#### 10. WINDOW

Always wear safety glasses when working around any glass to prevent glass fragments from damaging your eyes.

#### 11. WINDOW ADHESIVE

Always use the recommended or equivalent adhesive when attaching glass to prevent it from coming falling, resulting in accidents and injury.

#### 12. OIL

When handling oil, carefully observe the following to prevent unexpected accidents.

- Prepare container and waste cloths when performing work which oil could possibly spill. If oil spills, wipe it off immediately to prevent from penetrating into floor or flowing outside, for environmental protection.
- Follow all government regulations concerning disposal of refuse when disposing.

#### 13. FUEL

When handling and storing fuel, carefully observe the following to prevent unexpected accidents.

- Be careful of fires.
- Prepare a container and cloth to prevent scattering of fuels when performing work where fuels can be spilled. If the fuel spills, wipe it off immediately to prevent it from penetrating the floor or flowing out, to protect the environment.
- Follow all government and local regulations concerning disposal of refuse when disposing.

## 14. ENGINE COOLANT

When handling engine coolant, adhere to the following to prevent from unexpected accident.

- Never remove the radiator cap because of the danger of engine coolant blowing out when the engine coolant is hot.
- Prepare a container and cloth to prevent spraying of engine coolant when performing work in which engine coolant can be spilled. If the fuel spills, wipe it off immediately to prevent from penetrating into floor or flowing out for environmental protection.
- Follow all government and local regulations concerning disposal of refuse when disposing.

## 15. AIR CONDITIONER REFRIGERANT

In order to prevent from global warming, avoid releasing air conditioner refrigerant into the atmosphere. Using a refrigerant recovery system, discharge and reuse it.

## 16. HOSE REMOVAL/INSTALLATION PROCEDURES

### 1. Hose Removal/Installation Pre-Procedures

- Be careful to inspect hoses so as not to use damaged or deformed hoses. Using such hoses could cause leakage or loss of oil, with leaked oil splashing on exhaust pipes or other hot parts, resulting in smoke or fire.
- Always remove hoses when performing work. Not removing the hoses and moving parts out of the way when performing procedures may damage the inside of hoses and cause other negative affects.

### 2. Hose Removal/Installation Procedures and Inspection

#### • Remove hoses according to the following instructions.

- If using the hose remover (general tool), do not use the sharp-pointed hose remover (hose plucker) as it may damage pipe surfaces or hoses.

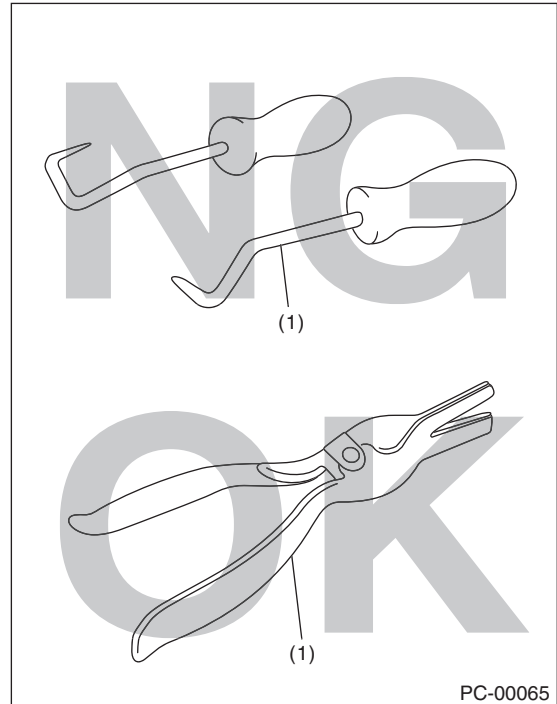

(1) Hose remover

- When using pliers to make hose removal easier, always be sure to use a cloth to protect the hose, slightly rotate the hose, and then pull straight out by hand.

# Precaution

## PRECAUTION

- **Inspect the following points in continuous use, and replace any hoses that are damaged or defective with new parts.**

- Replace any hoses that are riding over the stay or spool with new parts.

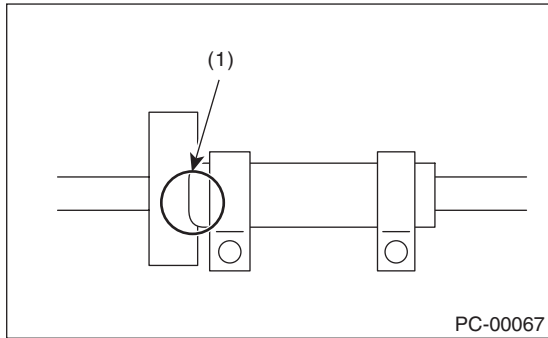

(1) Hose riding over a stay

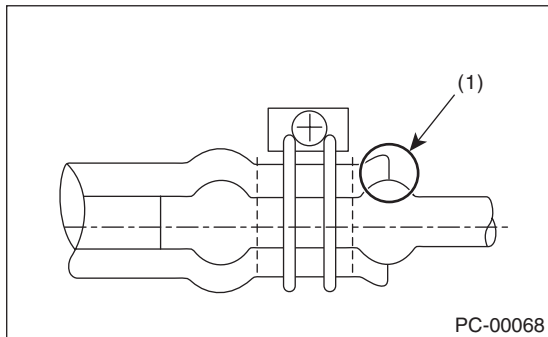

(1) Hose riding over a spool

- Check the inner and outer surfaces of the hose for damage, cracks, breakage, hardening/softening/swelling of rubber, internal peeling, and that there are no deformations caused by infiltration/adhesion of foreign matter, and no twisted hoses. Replace any defective hoses with new parts.

- **Install hoses according to the following instructions.**

- Carefully check the installation positions.
- Do not use any lubricants.
- Securely insert until the specified positions (until contacting spool).

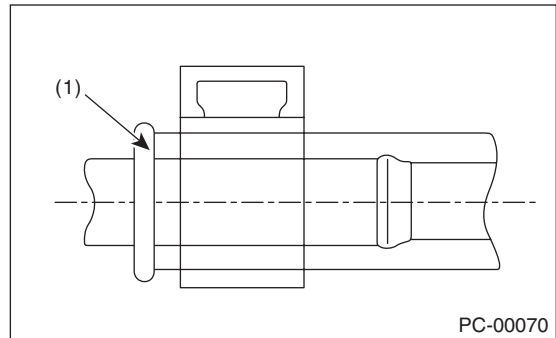
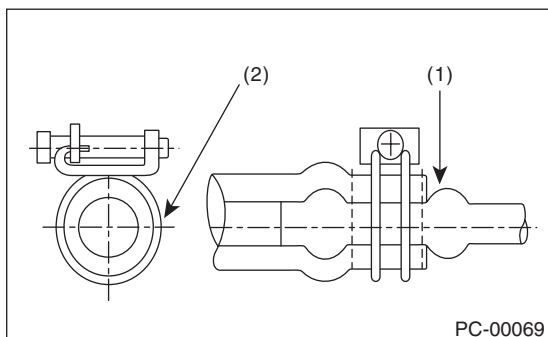

- (1) Contacting the spool. (Do not excessively insert the hose to prevent the hose from becoming wrinkled up.)
- (2) Apply an equal clamping force all around the hose periphery.

- Check that the position and orientation of hose clamps, and the hose layout are correct. (Check that the position and orientation are matching, they are not excessively short/long, there are no differences with before performing the procedures, and that there is clearance between hoses and surrounding parts.)
- After installing, check that there are no disconnection of hoses or leakage from hoses. (Check that hoses are securely fixed by the clamps.)
- **Inspect the hose clips and clamps according to the following points, and replace any parts that are damaged or defective with new parts.**
  - Check for deformations, rust, damage, and adhering of foreign matter.
  - For clips, check that the spring functions and has clamping force.
  - For clamps, check that the screw can clinch, the clamp has not become oval shaped, and the screw is not damaged.
- **Inspect the pipes according to the following points, and replace any parts that are damaged or defective with new parts.**

Check that the pipes do not have any damage, rust, peeling (including peeling plating), foreign matter adhering, twisting, crushing, bending, or cracks.
- **Replace the following parts with new parts if the hoses have been removed or their installation positions have been changed.**

ATF cooler hose, engine oil cooler hose, MT oil cooler hose, power steering suction hose, and power steering return hose.

# NOTE

***NT***

---

	<b>Page</b>
1. Note .....	2

