

Pre-delivery Inspection

PRE-DELIVERY INSPECTION

1. Pre-delivery Inspection

A: GENERAL DESCRIPTION

The purposes of the pre-delivery inspection (PDI) are as follows.

- Remove the additional parts used for ensuring the vehicle quality during transportation and restore the vehicle to its normal condition.
- Check the vehicle before delivery is in normal condition.
- Check the vehicle or parts for any damage occurred during transportation or storage.
- Check the vehicle after repair is in normal condition.
- Make sure to provide a complete vehicle to customer.

For above reasons, all SUBARU dealers (dealerships) must carry out the PDIs before delivery of vehicle.

Refer to this manual unless otherwise specified.

B: PRE-DELIVERY INSPECTION (PDI) PROCEDURE

STATIC CHECKS JUST AFTER VEHICLE RECEIPT

PROCEDURE	Check point
1. Appearance check	<ol style="list-style-type: none"> 1. If the vehicle is covered with protective coating, visually check the vehicle body for damage and dents. If the protective coating has been removed, visually check the body painted area for damage or stains in detail. 2. Visually check the glass and light lenses for any damage, cracks or excessive gaps between body sheet metal. 3. Visually check the plated parts for any damage.
2. Tire check	<ol style="list-style-type: none"> 1. Check the tires for damage, defective, and dents on wheels. 2. Check the tire air pressure.
3. Fuse installation	If the vehicle is about to be delivered to customer, attach a back-up fuse.
4. Air conditioner harness connection	If the vehicle is about to be delivered to the customer, connect the air conditioner harness.
5. Lock/unlock and open/close operation checks of doors	<ol style="list-style-type: none"> 1. Using the key, check the trunk lid can be locked or unlocked normally. 2. Open and close all doors to check that there are no defective. 3. Operate the power door lock switch to check that the door (rear gate) is locked and unlocked normally.
6. Operation check of child safety lock system	Check the child safety lock system operates normally.
7. Open/close operation checks of trunk lid	<ol style="list-style-type: none"> 1. Operate the trunk lock release lever to check that the trunk lid opens normally. 2. Check that main and sub keys can lock/unlock the release lever, and that valet key can not lock/unlock the release lever. 3. Open and close the trunk lid to see that there are no abnormal conditions.
8. Operation check of trunk lid release lever	Operate the trunk lid release lever to check that the trunk lock is unlocked normally.
9. Check the rear gate for lock/unlock and open/close operations	<ol style="list-style-type: none"> 1. Check if the rear gate can be unlocked normally through the emergency hole. 2. Open and close the rear gate to see that there are no abnormal conditions.
10. Operation check of fuel lid opener lock release lever	Operate the fuel lid opener to check that the fuel lid is unlocked normally.
11. Accessory check	<p>Check that the following accessories are provided.</p> <ul style="list-style-type: none"> • Owner's manual • Warranty booklet • Maintenance note • Spare key • Jack • Tool set • Spare tire
12. Operation check of front hood lock release system	Operate the front hood lock release lever to check that the front hood is unlocked normally.
13. Battery	Check the battery terminals for any abnormal conditions such as rust and trace of battery fluid leaks.
14. Brake fluid	Check that the fluid level is normal.
15. Engine oil	Check that the oil level is normal.
16. Transmission gear oil	Check that the transmission gear oil level is normal.
17. AT front differential oil	Check that the AT front differential oil level is normal.
18. Engine coolant	Check that the engine coolant level is normal.
19. Clutch fluid	Check that the clutch fluid level is normal.
20. Window washer fluid	Check that the window washer fluid level is normal.
21. Front hood latch check	Check that the hood is closed and latched securely.
22. Keyless entry system	Check that the keyless entry system operates normally.
23. Alarm system	Check that the alarm system operates normally.

Pre-delivery Inspection

PRE-DELIVERY INSPECTION

PROCEDURE	Check point
24. Seat	<ol style="list-style-type: none"> 1. Check the seat surfaces for stains or dirt. 2. Check the seat installation conditions and functionality. 3. Check that the occupant detection system for passenger's seat operates normally.
25. Seat belt	<ol style="list-style-type: none"> 1. Check the seat belt installation conditions and functionality. 2. Check that the seat belt warning system operates normally.

CHECKS WITH ENGINE RUNNING

PROCEDURE	Check point
26. Test mode connector	Test mode connector
27. Immobilizer system	<ol style="list-style-type: none"> 1. Check that the engine starts with all keys that are equipped on vehicle. 2. 60 seconds after turning ignition switch from ON to ACC or OFF, or immediately after removing the key, check that the security indicator light blinking.
28. Starting condition	Start the engine and check that the engine starts smoothly.
29. Exhaust system	Check that the exhaust noise is normal and no leaks are found.
30. Indicator and warning lights	Check that all the indicator and warning lights are gone out.
31. Clock	Check that the clock operates normally.
32. Audio	Check the radio, CD player for normal operation.
33. Navigation system	<ol style="list-style-type: none"> 1. Check all display functions for normal operation. 2. Check the map disc (DVD) are provided on vehicle. 3. Check that the navigation system operates normally.
34. Front accessory power supply socket	Check that the front accessory power socket operates normally.
35. Lighting system	Check that the lighting system operates normally.
36. Wiper deicer	Check that the wiper deicer operates normally.
37. Illumination control	Check that the illumination control operates normally.
38. Window washer	Check that the window washer system operates normally.
39. Wiper	Check that the wiper system operates normally.
40. Power window operation check	Check that the power window operations normally.
41. Sunroof	Check that the sunroof operates normally.
42. Door mirror	Check that the remote control mirror operates normally.

DYNAMIC TEST WITH THE VEHICLE RUNNING

PROCEDURE	Check point
43. Brake test	Check the foot brake for normal operations.
44. Parking brake	Check the parking brake for normal operations.
45. AT shift control	Check that the AT shift patterns are correct.
46. Heater and ventilation	Check that the heater and ventilation system operates normally.
47. Air conditioner	Check that the air conditioner operates normally.
48. Cruise control	Check that the cruise control system operates normally.

CHECKS AFTER DYNAMIC TEST

PROCEDURE	Check point
49. ATF level	Check that the ATF level is correct.
50. Power steering fluid level	Check that the power steering fluid level is normal.
51. Fluid leak check	Check for fluid/oil leaks.
52. Water leak test	Spray the vehicle with water and check for water leaks.
53. Appearance check 2	<ol style="list-style-type: none"> 1. Remove the protective coating (if equipped). 2. Check the body paints for damage and stain. 3. Check the plated parts for damage and rust.

1. APPEARANCE CHECK

- If the vehicle is covered with protective coating, visually check the vehicle body for damage and dents.
- When the protective coating is removed, visually check the body paints for damage or stains in detail and repair as necessary.
- Visually check the windshield glass, door glasses and light lenses for any damage, cracks or excessive gaps to the body sheet metal and repair as necessary.
- Visually check the plated parts, such as the grilles and door knobs, for damage or loss of gloss and replace the parts as necessary.

2. TIRE CHECK

- Check the tires for damage, defective, and dents on wheels.
- Check and adjust the tire size, spare tire and tire air pressure described on the tire air pressure label (driver's side).

3. FUSE INSTALLATION

Fuses for the back-up circuit have been removed to prevent battery discharge. If the vehicle is about to be delivered to the customer, attach a 20 A fuse (A) as shown in the figure.

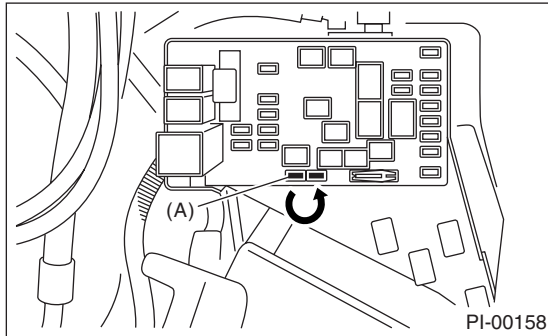

4. AIR CONDITIONER HARNESS CONNECTION

Disconnect the air conditioner harness immediately after vehicle delivery to protect the air conditioner compressor. Connect the harness as shown in the figure. (Except for 3.0 L model)

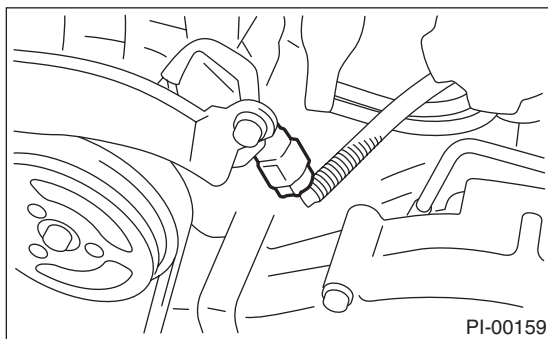

5. CHECK THE DOORS FOR LOCK/UNLOCK AND OPEN/CLOSE OPERATIONS

1) Using the key, lock and unlock the door several times to check for normal operation. Open and close the door several times for smooth movement.

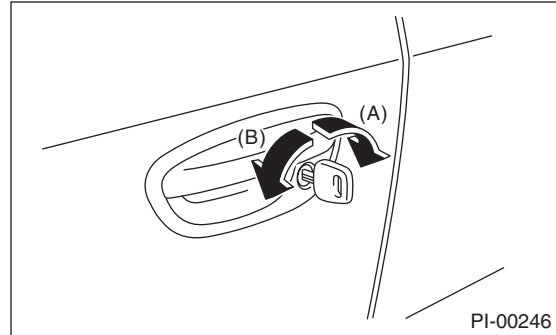

- (A) Unlock
- (B) Lock

2) Completely close the driver's door, and then check the smooth movement with operating door lock knob from lock to unlock several times. Set the door lock knob (A) to lock position. Then pull the inner remote (B) to ensure that doors will not open. For other doors, place the door lock knob (A) to lock position and then pull the inner remote (B) to ensure that doors will not open.

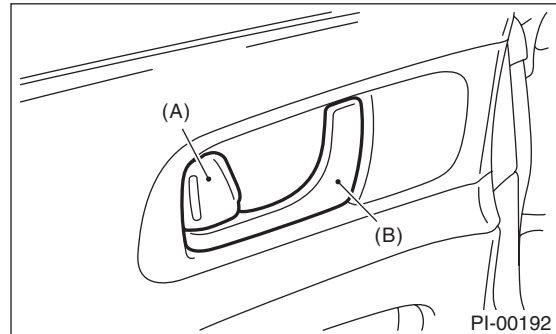

- (A) Door lock knob
- (B) Inner remote

3) Close all the doors, and then press the lock on power door lock switch at driver's side. Check that all doors including rear gate are locked.

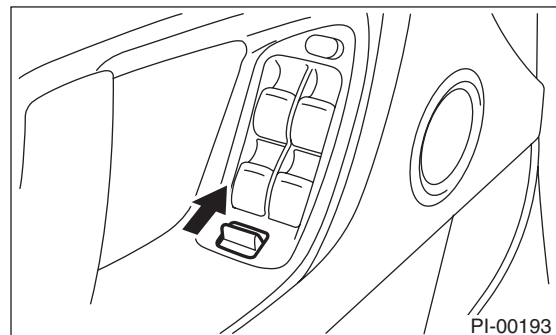

Pre-delivery Inspection

PRE-DELIVERY INSPECTION

4) Press the driver's side power door lock switch to unlock side. Check that all doors including rear gate are unlocked.

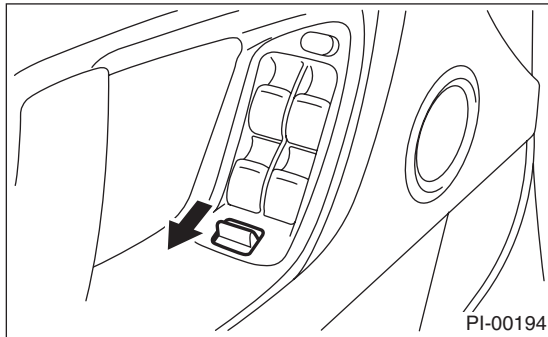

5) Check that the power door lock switch on the passenger's side also locks and unlocks.

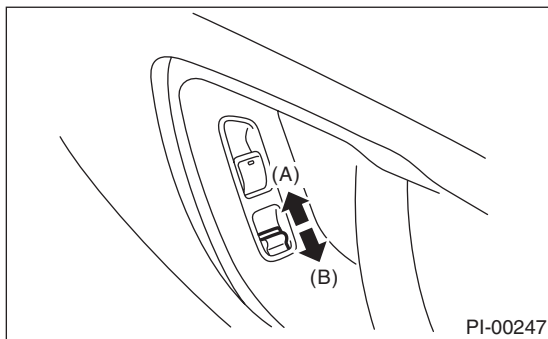

- (A) Lock
- (B) Unlock

6) Insert the key to ignition switch, and open the driver's side door. Press lock on power door lock. Check that the door is not locked.

6. CHECK THE OPERATION OF CHILD SAFETY LOCK SYSTEM

- 1) Set the child safety lock on both rear doors to the lock position.
- 2) Close the rear doors completely.
- 3) Check that the lock levers of the rear doors are in the unlock position. Then, pull inner remote of rear doors to ensure that the doors will not open.

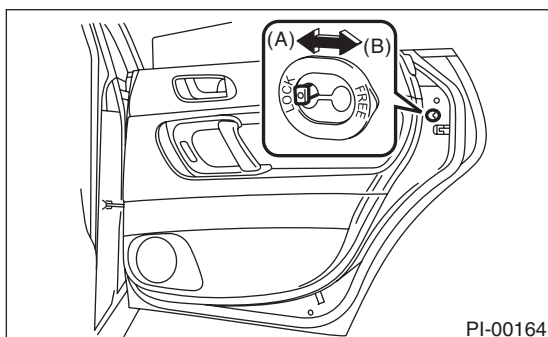

- (A) Lock
- (B) Unlock

4) Pull the outer handles to ensure that doors will open.

7. OPEN/CLOSE OPERATION CHECKS OF TRUNK LID

- 1) Operate the trunk lock release lever to check that the trunk lid opens normally.
- 2) Open and close the trunk lid several times for smooth movement.
- 3) Lock the trunk lock release lever using main key or sub key.

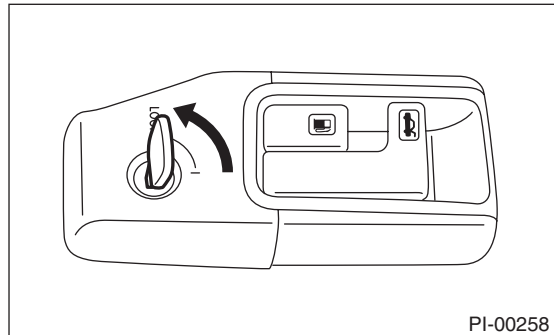

- 4) Check that the trunk lock release lever does not operate.
- 5) Check if the trunk lock release lever is not locked and unlocked using valet key.

8. OPERATION CHECK OF TRUNK LID RELEASE HANDLE

1) Use a flat tip screwdriver. Slide the screwdriver blade from the slit aperture of the lock assembly fully to the end until you hear a click. This places the latch in the locked position.

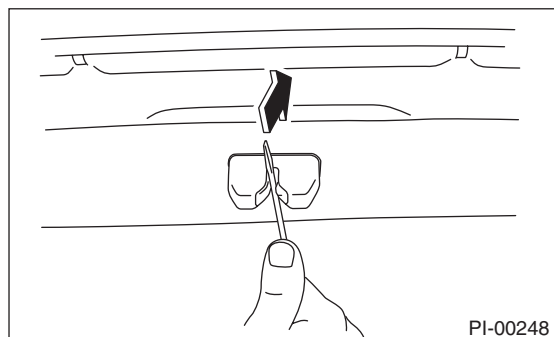

2) Move the release handle from outside the vehicle in the direction of the arrow to check if the latch is released.

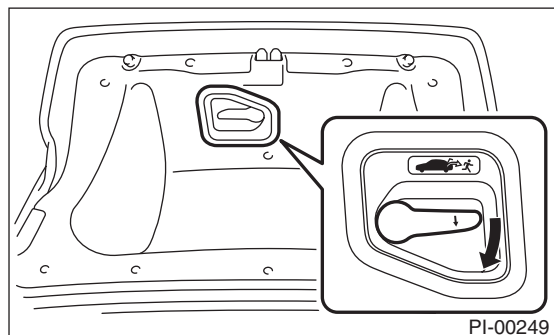

9. CHECK THE REAR GATE FOR LOCK/ UNLOCK AND OPEN/CLOSE OPERATIONS

- 1) Open and close the rear gate several times for smooth movement.
- 2) Operate the rear gate lever to check that the rear gate is locked and unlocked normally.

(1) Remove the cover inside the rear gate.

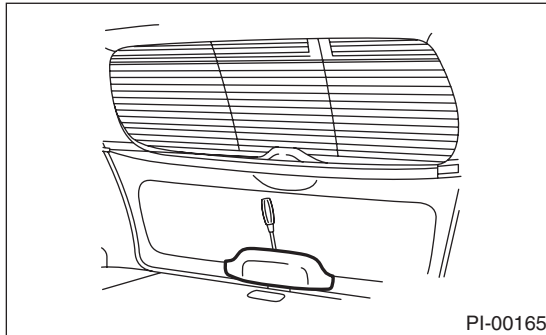

(2) Operate the lever to check that the rear gate is locked and unlocked normally.

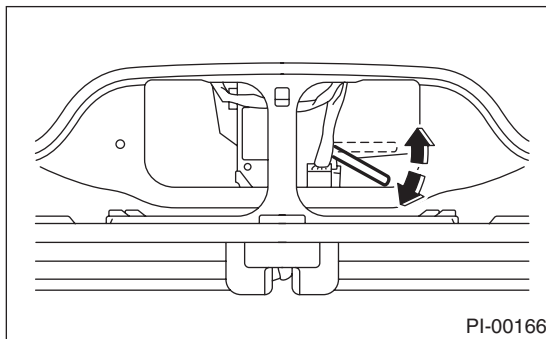

10. OPERATION CHECK OF FUEL LID OPENER LOCK RELEASE LEVER

Operate the fuel lid opener to check that the fuel lid is unlocked normally. Check that the filler cap is securely closed.

11. ACCESSORY CHECK

Check that the following accessories are provided.

- Owner's manual
- Warranty booklet
- Maintenance note
- Spare key
- Jack
- Tool set
- Spare tire

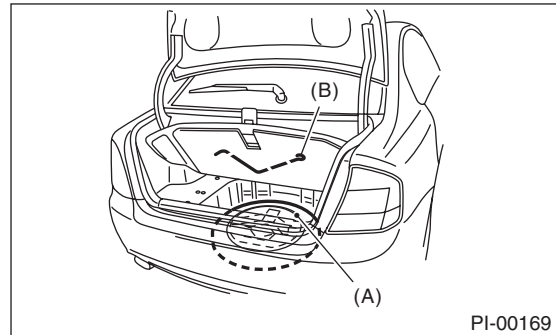
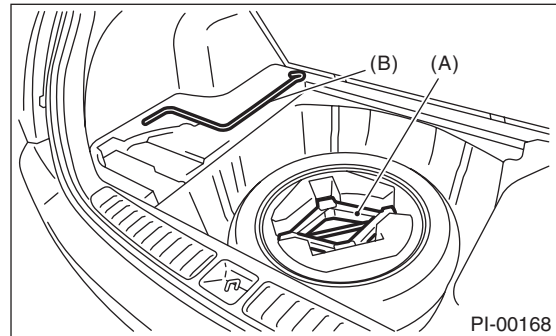

- (A) Jack
(B) Jack handle

12. OPERATION CHECK OF FRONT HOOD LOCK RELEASE SYSTEM

Operate the front hood lock release lever (A) to check that the front hood is unlocked normally.

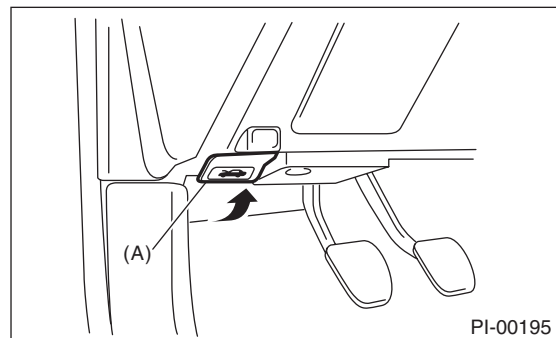

Pre-delivery Inspection

PRE-DELIVERY INSPECTION

Operate the lever (B) and check that the front hood is opened normally. Support the front hood with hood stay.

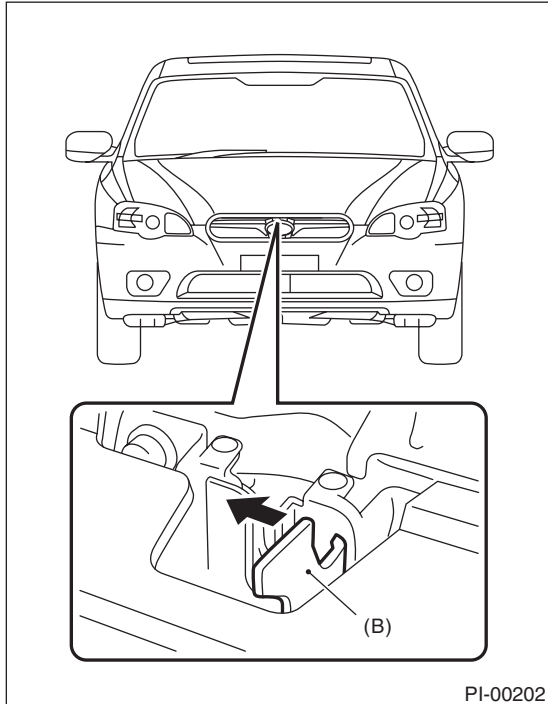

13.BATTERY

Check the battery terminals to make sure that there are no rust or corruptions due to fluid leaks.

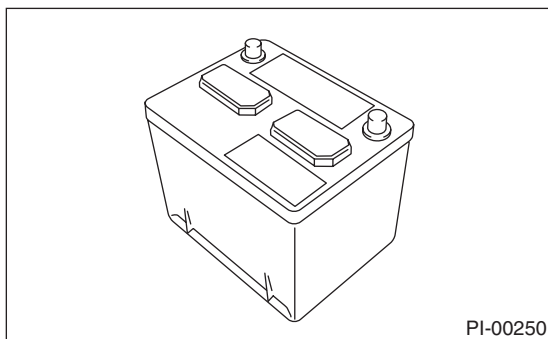

14.BRAKE FLUID

Check that the brake fluid level is normal. If the amount is insufficient, carry out a brake line test to identify brake fluid leaks and check the brake operation. After that, refill the brake fluid tank with the specified type of fluid.

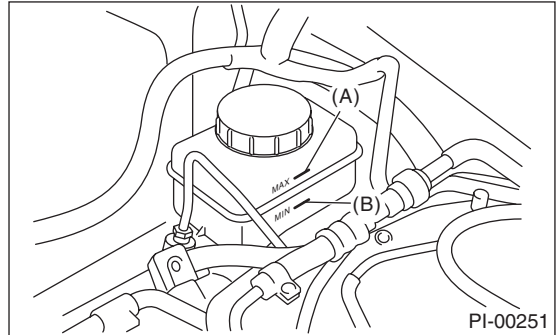

- (A) MAX. level
- (B) MIN. level

15.ENGINE OIL

Check the engine oil amount. If the amount of oil is insufficient, check that no leaks are found. Then, add the necessary amount of the specified engine oil.

- Except for 3.0 L model

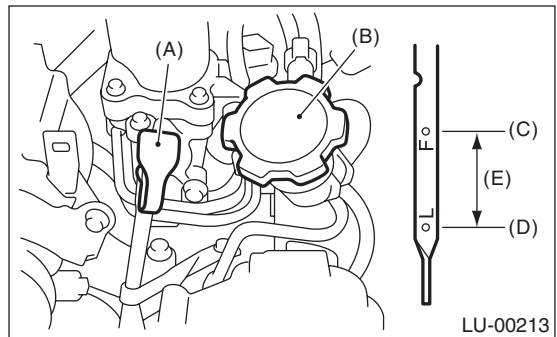

- (A) Oil level gauge
- (B) Engine oil filler cap
- (C) Upper level
- (D) Lower level
- (E) Approx. 1.0 ℓ (1.1 US qt, 0.9 Imp qt)

- 3.0 L model

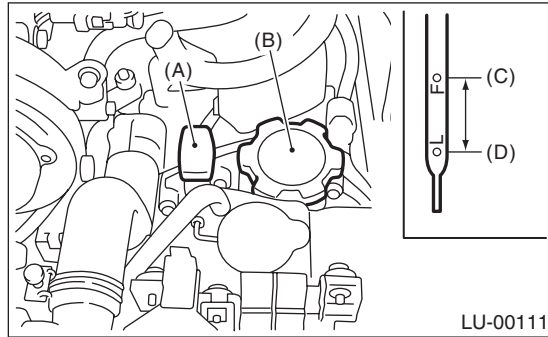

- (A) Oil level gauge
- (B) Engine oil filler cap
- (C) Upper level
- (D) Lower level

16. TRANSMISSION GEAR OIL

Check that the transmission gear oil level is normal. If the amount of fluid is insufficient, check that no leaks are found. Then add the necessary amount of the specified transmission gear oil.

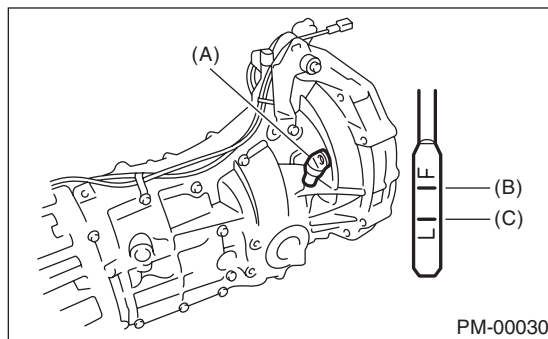

- (A) Oil level gauge
- (B) Upper level
- (C) Lower level

17. AT FRONT DIFFERENTIAL OIL

Check that the AT front differential oil level is normal. If the amount of oil is insufficient, check that no leaks are found. Then, add the necessary amount of the specified AT front differential oil.

- 4AT model

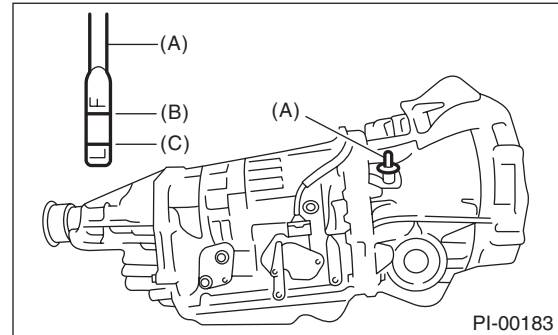

- (A) Oil level gauge
- (B) Upper level
- (C) Lower level

- 5AT model

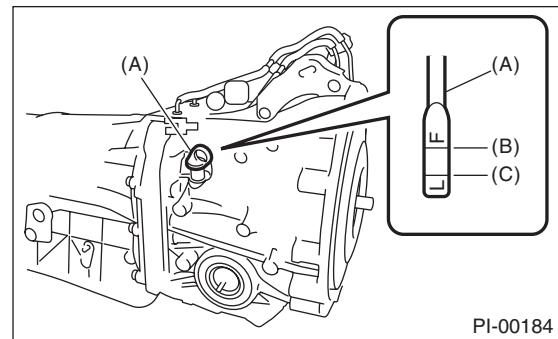

- (A) Oil level gauge
- (B) Upper level
- (C) Lower level

18. ENGINE COOLANT

Check that the engine coolant level on the reservoir tank is normal. If the amount of engine coolant is insufficient, check that no leaks are found. Then, add the necessary amount of coolant with the specified concentration.

Pre-delivery Inspection

PRE-DELIVERY INSPECTION

19. CLUTCH FLUID

Check that the clutch fluid level is normal. If the amount of fluid is insufficient, check that no leaks are found. Then, add the necessary amount of specified fluid.

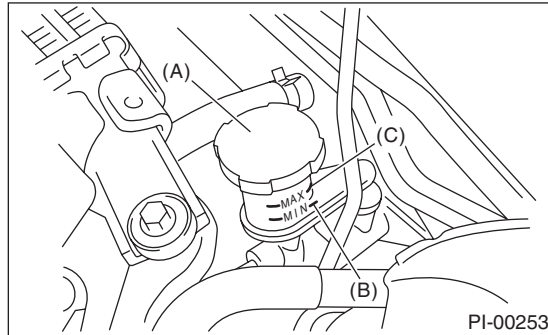

- (A) Reservoir tank
- (B) MIN. level
- (C) MAX. level

20. WINDOW WASHER FLUID

Check that the window washer fluid level is normal. If the amount is insufficient, check that no leaks are found. Then, add the necessary amount of washer fluid.

21. FRONT HOOD LATCH CHECK

Retract the front hood stay and close the front hood. Check that the front hood is securely latched.

22. KEYLESS ENTRY SYSTEM

NOTE:

The following inspections show the initial settings. When the settings are different from the initial settings, use Subaru Select Monitor to check the details of each setting for inspections. <Ref. to LAN(diag)-27, OPERATION, Read Current Data.>

- 1) Fully open all the door windows.
- 2) Remove the key from the ignition switch and close all the doors including rear gate.
- 3) Press the rear gate and trunk open button for more than one second.
 - Check if the trunk is opened and the hazard light blinks twice and the buzzer sounds twice. (Sedan model)
 - Check if the rear gate is unlocked and the hazard light blinks twice and the buzzer sounds twice. (Wagon model)

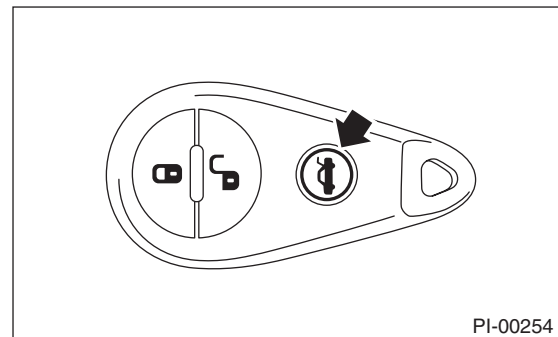

- 4) Press the "LOCK" button on the keyless transmitter with one of the doors (including the rear gate and trunk) opened. Check if all the doors are locked, hazard light blinks five times and the buzzer sounds five times and warning shows one of the doors (including the rear gate and trunk) open.
- 5) Close all the doors including rear gate and trunk. Press the "LOCK" button momentarily on the keyless transmitter. Check that all the doors (including rear gate and trunk) are locked, hazard light blinks once and buzzer sounds once.

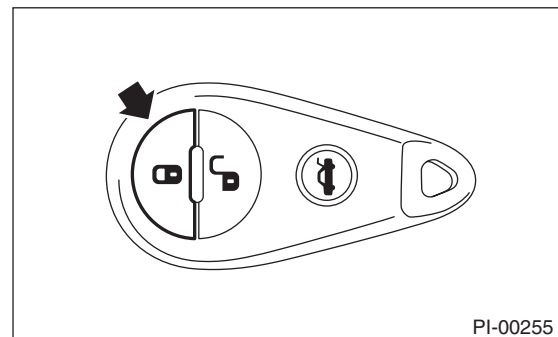

6) Press the “UNLOCK” button momentarily on the keyless transmitter. Check that the driver’s door is unlocked and hazard light blinks twice and the buzzer sounds twice.

And press the “UNLOCK” button momentarily again in 5 seconds. Check that all the doors including rear gate are unlocked.

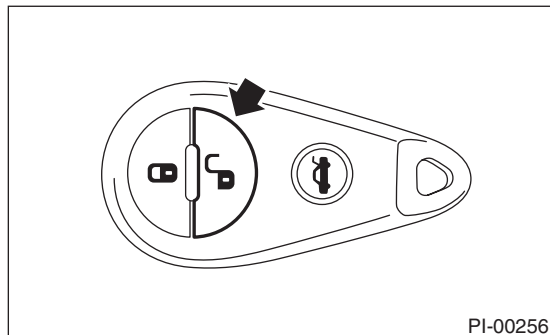

7) Within a distance of 10 m (33 ft) from a vehicle, press keyless transmitter’s “LOCK” button three times within 5 seconds. Check that the horn honks once and that the hazard light blinks three times.

8) Move the power door lock switch to the lock position with one of doors (including the rear gate) opened. Next, close all the doors including rear gate. Check if all the doors are locked and buzzer sounds once and the hazard light flashes once.

9) Check buzzer operation

The buzzer rings when the doors are locked or unlocked. The buzzer can be turned off if desired. Turn the buzzer off or on with following procedure.

- (1) Close all the doors including rear gate, then remove the key from ignition key lock.
- (2) Press the power door lock switch to unlock and hold it until the operation is finished.
- (3) Insert the key into ignition key lock, and insert and remove the key in ignition key lock 5 times in 10 seconds.
- (4) When finished step (3), open and close the driver’s door once within 10 seconds.

NOTE:

When opening and closing of the door is not available within 10 seconds, hazard light blinks once and the change over operation is cancelled. Retry from the step (1).

- (5) Hazard light blinks 3 times and the buzzer sound turns ON or OFF.

10) Press the “Panic” button on the backside of the keyless transmitter. Check if the alarm condition happens (horn sounds continuously, hazard light blinks, security indicator comes on). Check whether this condition lasts until any button on the keyless transmitter is pressed or lasts for 30 seconds.

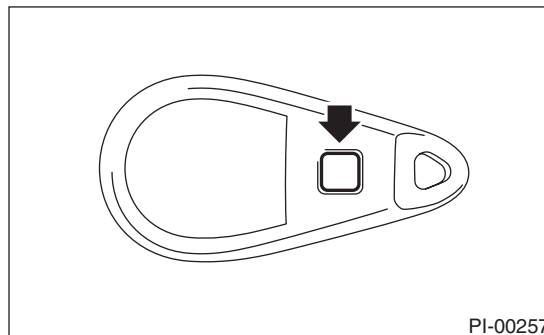

23.ALARM SYSTEM

NOTE:

The following inspections show the initial settings. When the settings are different from the initial settings, use Subaru Select Monitor to check the details of each setting for inspections. <Ref. to LAN(diag)-28, OPERATION, Function Setting (Customize).>

- 1) Fully open all the door windows.
- 2) Remove the key from the ignition switch and close all the doors including rear gate.
- 3) Press the “LOCK” button momentarily on the keyless transmitter. All doors are locked, and buzzer sound once, hazard blinks once, security indicator light blinks fast (five times per two seconds) for 30 seconds and goes slower (twice per two seconds), then the alarm system is in set condition.

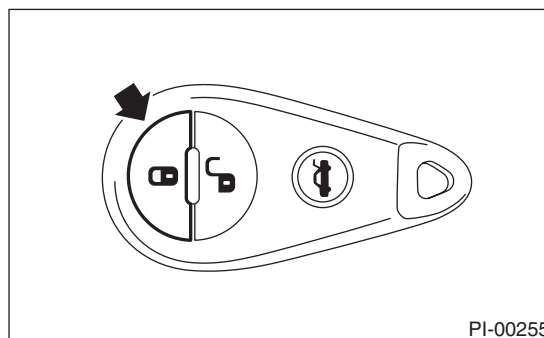

Pre-delivery Inspection

PRE-DELIVERY INSPECTION

4) Press the “UNLOCK” button momentarily on the keyless transmitter. When the door of the driver’s seat is unlocked, the buzzer sounds twice, the hazard light flashes twice, the room light turns on and the security indicator light flashes once in three seconds, and the alarm system enters the release mode.

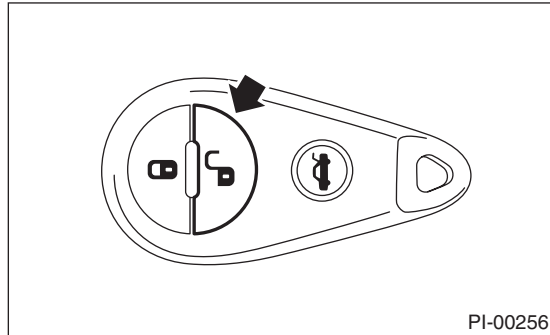

5) Close all the doors including rear gate. Press the “LOCK” button momentarily on the keyless transmitter. When all the doors are locked, buzzer sounds once, hazard blinks once and the alarm system is in set condition in 30 seconds.

6) Unlock a door using the inner lock knob and open the door while the security system is in the set mode. Check if the alarm condition happens (horn sounds continuously, hazard light blinks, security indicator comes on). Check if this condition lasts for a maximum of three minutes or until the “UNLOCK” button of the keyless transmitter is pressed.

NOTE:

The alarm condition will cease in 30 seconds once the door is closed.

7) When none of above is applicable, check the troubleshooting of security system.

24. SEATS

- 1) Check the seat surfaces for stains or dirt.
- 2) Check that each seat provides full functionality in sliding and reclining. Check all available functions of the rear seat such as a trunk-through center armrest.
- 3) Check the passenger’s seat occupant detection system.

(1) Turn the ignition switch to ON.

(2) Check that the ON and OFF of passenger’s airbag indicator light come on simultaneously for about 6 seconds and go off for 2 seconds, and then only OFF comes on again.

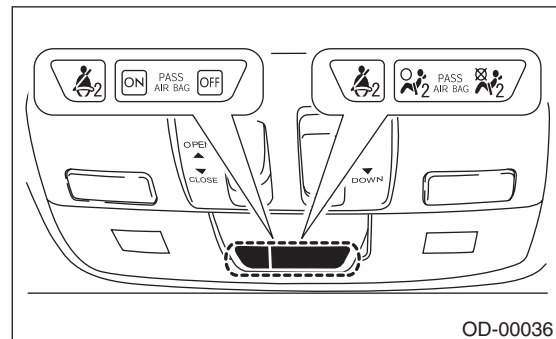

(3) With a person weighing approximately 70 kg (155 lb) or more sitting in the passenger’s seat, check whether the passenger’s airbag indicator light illuminates or not.

(4) Empty the passenger seat, then check whether the passenger side airbag indicator light turns off.

25. SEAT BELT

- 1) Check installation condition of seat belt.
- 2) Pull out the seat belt and then release it. Check that the belt retracts smoothly.
- 3) Check seat belt warning system
 - (1) Turn the ignition switch to ON without fastening driver’s and passenger’s seat belts.
 - (2) Check if the seat belt warning lights of driver’s and passenger’s side blink for about six seconds and the buzzer beeps intermittently.
 - (3) Then, check that the seat belt warning light comes on → blink → buzzer beeps in about 15 seconds cycles. (If the passengers seat is empty, seat belt warning light for passengers side does not operate.)

26. TEST MODE CONNECTOR

Turn the ignition switch to ON and check that the malfunction indicator light starts blinking. If the light blinks, return the ignition key to LOCK. Pull out the test mode connector from the back of glove box lower cover, and disconnect the test mode connector. Then, turn the ignition key to ON again. If the malfunction indicator light blinks at that time in spite of the disconnected test mode connector, carry out an engine diagnosis.

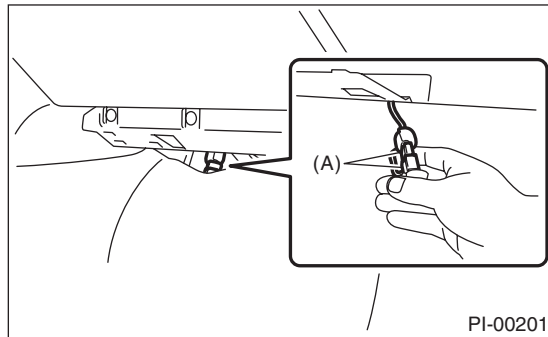

(A) Test mode connector (green)

27. IMMOBILIZER SYSTEM

- 1) Check that the engine starts with all keys that are equipped on vehicle.
- 2) 60 seconds after turning ignition switch from ON to ACC or OFF, or immediately after removing the key, check that the security indicator light blinking.

NOTE:

If malfunctions occur, refer to "IMMOBILIZER (DIAGNOSIS)".

28. STARTING CONDITION

Start the engine and check that the engine starts smoothly. If the battery voltage is low, recharge or replace the battery. If any noises are observed, immediately stop the engine and check and repair the abnormal components.

29. EXHAUST SYSTEM

Listen to the exhaust noise to see if no noises are observed. Check for exhaust leaks.

30. INDICATOR AND WARNING LIGHTS

Check that all the indicator and warning lights are off.

31. CLOCK

Check the clock for normal operations and enough accuracy.

32. AUDIO

Check the radio for full functionality and normal noise level. Check the CD unit operations.

33. NAVIGATION SYSTEM

- 1) Check all display functions for normal operation.
- 2) Check the map disc (DVD) are provided on vehicle.
- 3) Check that the navigation system operates normally.

34. FRONT ACCESSORY POWER SUPPLY SOCKET

- 1) Check the operation of the front accessory power socket.
- 2) Check operation of the accessory power socket in console box.

35. LIGHTING SYSTEM

- 1) Check the headlight operations.
- 2) Check the stop light operation.
- 3) Check other lights for normal operations.

36. WIPER DEICER

Check that the wiper deicer operates normally.

37. ILLUMINATION CONTROL

Check that the illumination control operates normally.

Pre-delivery Inspection

PRE-DELIVERY INSPECTION

38. WINDOW WASHER

Check that the window washer system injects washer fluid to the specified area of the windshield shown in the figure.

Front injection position:

A: 250 mm (9.84 in)

B: 535 mm (21.1 in)

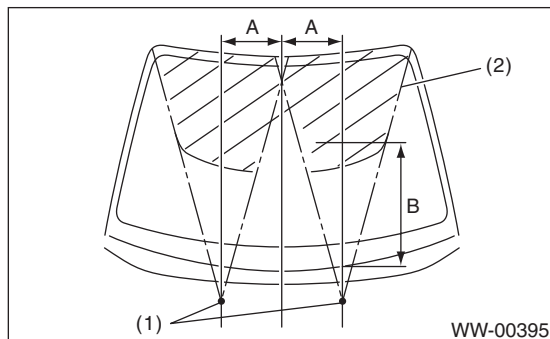

(1) Nozzle

(2) Spray area (shaded area)

Rear injection position:

WAGON MODEL

A: 70 mm (2.8 in)

B: 70°

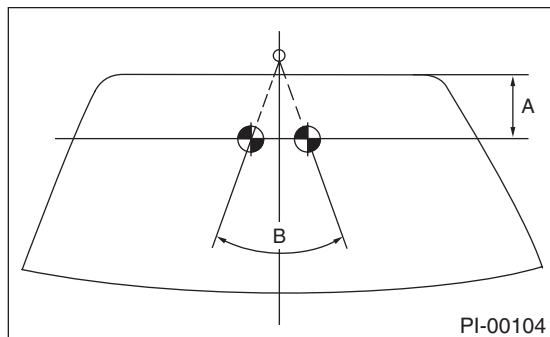

39. WIPER

Check the front and rear wipers for normal operations.

40. POWER WINDOW OPERATION CHECK

Operate the power window switches one by one to check that each of the power windows goes up and down without noises.

41. SUNROOF

Check that the sunroof operates normally.

42. DOOR MIRROR

Check that the remote control mirror operates normally.

43. BRAKE TEST

Check the foot brake for normal operations.

44. PARKING BRAKE

Check the parking brake for normal operations. When pulling the parking brake lever with force of 200 N (20.4 kgf, 45.0 lb), check that the lever stroke of parking brake lever is 5 to 6 notches.

45. AT SHIFT CONTROL

- 1) Turn the ignition switch to ON.
- 2) While brake pedal is not depressed, check if the select lever does not move from "P" range.
- 3) While brake pedal is depressed, check if the select lever moves from "P" range.
- 4) Set the select lever to other than "P" range.
- 5) When the ignition switch is turned to OFF, check if the ignition key switch cannot be removed.
- 6) Set the AT selector lever to each gear position and check the shifting while driving the vehicle.

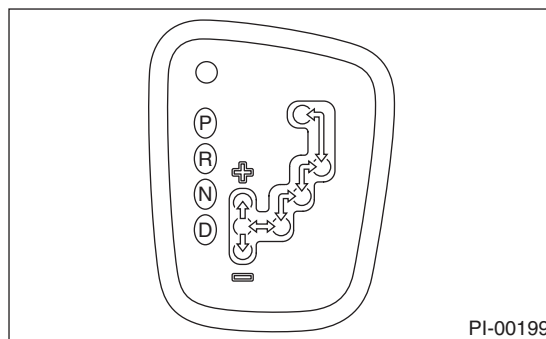

• 4AT

Selector Position	Gear position			
	1st	2nd	3rd	4th
D	OK	OK	OK	OK
SPORT shift	OK	OK	OK	OK

• 5AT

Selector Position	Gear position				
	1st	2nd	3rd	4th	5th
D	OK	OK	OK	OK	OK
SPORT shift	OK	OK	OK	OK	OK

46. HEATER AND VENTILATION

Operate the heater and ventilation system to check for normal airflow outlet control, air inlet control, airflow capacity and heating performance.

47. AIR CONDITIONER

Operate the air conditioner. Check that the A/C compressor operates normally and enough cooling is provided.

48. CRUISE CONTROL

Operate the cruise control system. Check that the system is activated and deactivated correctly.

49. ATF LEVEL

After selecting all positions (P, R, N, D), set the select lever in “P” range. Idle the engine for 1-2 minutes, and measure the ATF level. If the amount is insufficient, check that no leaks are found. Then, add the necessary amount of the specified ATF.

- 4AT

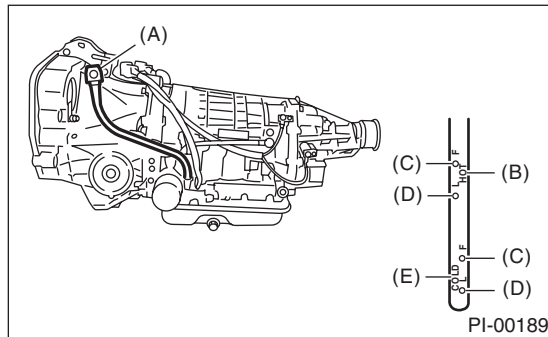

- (A) Level gauge
- (B) ATF level range at “HOT” [70 — 80°C (158 — 176°F)]
- (C) Upper level
- (D) Lower level
- (E) ATF level range at “COLD” [20 — 30°C (68 — 86°F)]

- 5AT

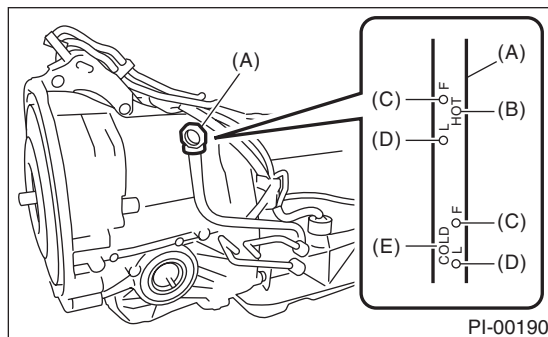

- (A) Level gauge
- (B) ATF level range at “HOT” [70 — 80°C (158 — 176°F)]
- (C) Upper level
- (D) Lower level
- (E) ATF level range at “COLD” [20 — 30°C (68 — 86°F)]

50. POWER STEERING FLUID LEVEL

Check that the power steering fluid level is normal. If the amount is insufficient, check that no leaks are found. Then add the necessary amount of the specified power steering fluid.

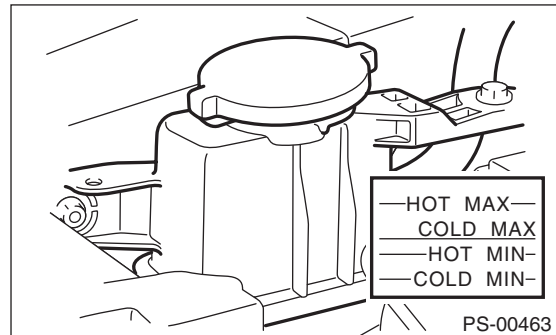

51. FLUID LEAK CHECK

Check entire areas of the vehicle for any trace of coolant/oil/fluid leaks.

52. WATER LEAK TEST

Spray the vehicle with water using a hose and check that no water enters the passenger compartment.

- Before performing the water leakage test, remove anything that may obstruct the operation or which must be kept dry.
- Close all the windows and doors securely. Close the hood and trunk lid before starting the test.
- Spray the vehicle with water using a hose. The rate of water spray must be approx. 20 — 25 ℓ (5.3 — 6.6 US gal, 4.4 — 5.5 Imp gal) per minute.

When spraying water on areas adjacent to the floor and wheel house, increase the pressure. When spraying water on areas other than the floor and wheel house, decrease the pressure. But the force of water must be made strong occasionally by pressing the end of the hose.

NOTE:

Be sure to keep the hose at least 10 cm (3.9 in) away from vehicle.

Check the following areas.

- Front window and body framework mating portion
- Door mating portions
- Glass mating portions
- Rear quarter window mating portions
- Rear window and body framework mating portion
- Around roof drips

If any dampness in the compartments is discovered after the water has been applied, carefully check all the areas that may have possibly contributed to the leak.

Pre-delivery Inspection

PRE-DELIVERY INSPECTION

53. APPEARANCE CHECK 2

1) When vehicle body is covered with protective film, peel it off.

NOTE:

- Use of steam facilitates peeling off the wrap guard.
- For a vehicle left for a long time or at low temperature, sprinkle some water heated to 50 — 60°C (122 — 140°F) over the vehicle to raise its surface temperature before peeling off the wrap guard. Do not use the water heated to over 60°C (140°F).
- If the adhesive remains exist on the coated surface, soak a flannel rag, etc. with a small amount of coating wax or solvent such as oil benzene and IPA, put the soaked cloth on the remains lightly, and then wipe them off with a flannel rag etc.
- Keep solvent from touching the resin or rubber parts. Do not use coating wax or solvent while the component surface temperature is high due to hot weather etc.
- If the coated surface is swollen out due to seams or moisture, expose the vehicle to the sunlight for a few hours or heat the seam and swollen portions using a dryer etc.
- Dispose of the peeled wrap guard as burnable industrial garbage.

2) Check the whole vehicle body for flaking paint, damage by transportation, corrosion, dirt, cracks or blisters.

NOTE:

- It is better to determine an inspection pattern in order to avoid missing an area, since the total inspection area is wide.
- Do not repair the body paint unless absolutely necessary. Also, if the vehicle is in need of repair to remove scratches or corroded paint, the repair area must be limited to the minimum. Re-painting and spray painting must be avoided as possible.

3) Check each window glass for scratches carefully. Slight damage may be removed by polishing with cerium oxide. (Fill a cup half with cerium oxide, and add warm water to it. Then agitate the content until it turns to wax. Apply this wax to a soft cloth, and polish the glass with it.)

4) Check each portion of the vehicle body and underside components for the formation of rust. If rust is discovered, remove it with sandpaper of #80 to #180 and treat the surface with rust preventive. After this treatment is completed, flush the portion thoroughly, and prepare the surface for repair painting.

5) Check each portion of body and all of the plated parts for deformation or distortion. Also, check each light lens for cracks.

6) Peel the protective tape, vinyl wrapping and identification seal attached to the following places.

- Seats
- Door trim
- Floor carpet
- Side sill
- Front hood lock release lever
- Edge rear
- Rear wiper
- Sedan rear combination light (Trunk lid opening portion)
- Roof rail
- Door mirror

PERIODIC MAINTENANCE SERVICES

PM

	Page
1. General Description	2
2. Schedule	3
3. Engine Oil	9
4. Engine Oil Filter	11
5. Spark Plug	13
6. V-belt	14
7. Timing Belt	17
8. Fuel Line	20
9. Air Cleaner Element	21
10. Cooling System	22
11. Engine Coolant	24
12. Clutch System	26
13. Transmission Gear Oil	27
14. Automatic Transmission Fluid	28
15. Front & Rear Differential Gear Oil	30
16. Brake Line	32
17. Brake Fluid	34
18. Disc Brake Pad and Disc	35
19. Parking Brake	36
20. Suspension	37
21. Wheel Bearing	39
22. Axle Boots & Joints	40
23. Tire Rotation	41
24. Steering System (Power Steering)	42
25. Supplemental Restraint System	45