

## 16. Brake Line

### A: INSPECTION

#### 1. BRAKE LINE

- 1) Check for scratches, swelling, corrosion, traces of fluid leakage on the brake hoses or pipe joints.
- 2) Check the possibility of adjacent parts interfering with brake pipes/hoses during driving, and loose connections/clamps.
- 3) Check any trace of fluid leakage, scratches, etc. on master cylinder, wheel cylinder and pressure control valve.

**NOTE:**

- When the brake fluid level in the reservoir tank is lower than specified limit, the brake warning light on the combination meter will come on.
- Visually check the brake hose for damage. (Use a mirror where it is difficult to see)

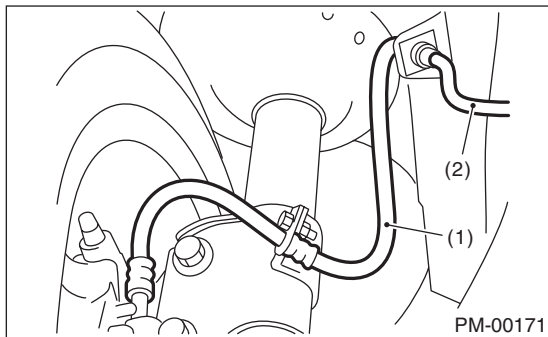

- (1) Front brake hose
- (2) Front brake pipe

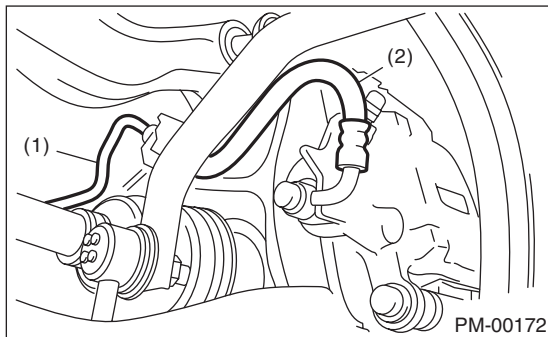

- (1) Rear brake pipe
- (2) Rear brake hose

#### 2. SERVICE BRAKE

- 1) Check the free play of brake pedal with pulling up the force of less than 10 N (1 kgf, 2 lb).

**Brake pedal free play (Pulling up direction of pedal)**

**0.5 — 2.0 mm (0.02 — 0.08 in)**

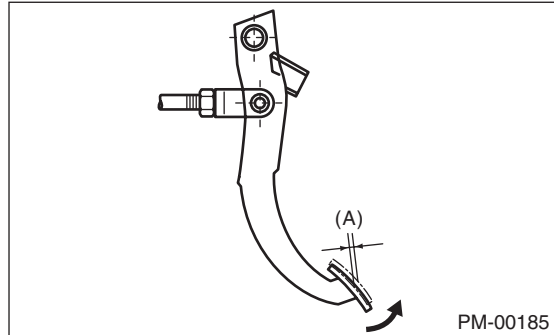

(A) Pedal free play

- 2) If the free play is out of specifications above, adjust the brake pedal as follows.

- (1) Make sure the engine is off. (No vacuum is applied to brake booster.)
- (2) There should be play between brake booster clevis and pin at brake pedal installing portion. [Pulling up the brake pedal pad with a force of less than 10 N (1 kgf, 2 lb) to a stroke of 0.5 to 2.0 mm (0.02 to 0.08 in).]
- (3) If there is no free play between clevis pin and clevis, turn brake switch adjusting nut until the clearance between stopper and screw of brake switch becomes 0.3 mm (0.012 in).

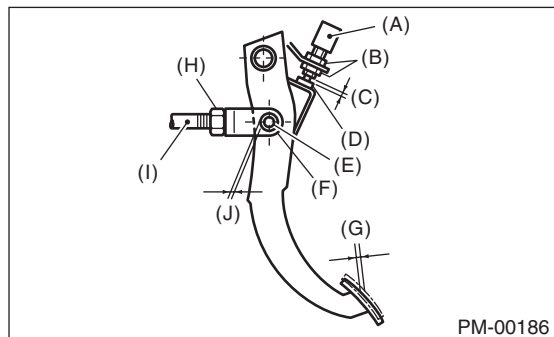

- (A) Brake switch
- (B) Adjusting nut
- (C) 0.3 mm (0.012 in)
- (D) Stopper
- (E) Clevis pin
- (F) Clevis
- (G) Pedal free play
- (H) Lock nut
- (I) Brake booster operating rod
- (J) Play at pin

### 3) Check the pedal stroke.

While the engine is idling, depress the brake pedal with a 490 N (50 kgf, 110 lb) load and measure the distance between the brake pedal and steering wheel. With the brake pedal released, measure the distance between pedal and steering wheel again. The difference between the two measured values must be less than specified value. If the measured value is more than specification, there is possibility of entering air in hydraulic unit.

#### **Brake pedal stroke A:**

**95 mm (3.7 in)/ 490 N (50 kgf, 110 lb) or less**

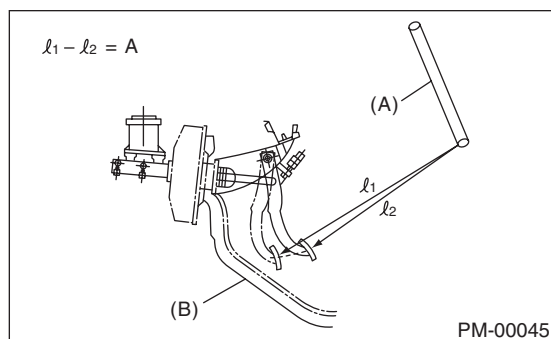

- (A) Steering wheel
- (B) Toe board

4) Check to see if air is in the hydraulic brake line by the feel of pedal operation. If air appears to exist in the line, bleed it from the system.

5) Check for even operation of all brakes, using a brake tester or by driving the vehicle for a short distance on a straight road.

### 3. BRAKE SERVO SYSTEM

1) With the engine off, depress the brake pedal several times applying the same pedal force. Make sure the travel distance should not change.

2) With the brake pedal depressed, start the engine. Make sure the pedal should move slightly toward the floor.

3) With the brake pedal depressed, stop the engine and keep the pedal depressed for 30 seconds. Make sure the pedal height should not change.

4) A check valve is incorporated into the brake booster nipple part. Disconnect the vacuum hose to inspect function of check valve.

Make sure air flows from the booster end to engine end but does not flow in the opposite direction in the check valve.

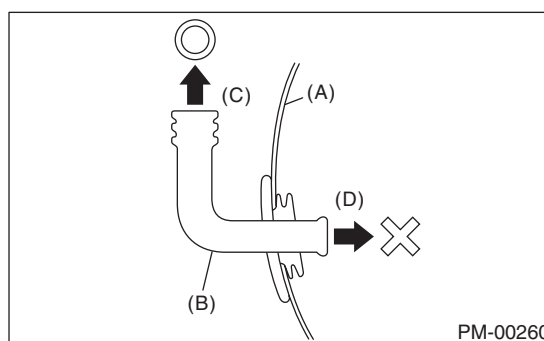

- (A) Brake booster
- (B) Check valve
- (C) Engine side
- (D) Brake booster side

5) Check the vacuum hose for cracks or other damage.

#### NOTE:

When installing the vacuum hose on the engine and brake booster, do not use soapy water or lubricating oil on their connections.

6) Check the vacuum hose to make sure it is tightly secured.