

# Brake Fluid

## PERIODIC MAINTENANCE SERVICES

### 17. Brake Fluid

#### A: REPLACEMENT

- 1) Either jack-up the vehicle and place a rigid rack under it, or lift-up the vehicle.
- 2) Remove all the wheels.
- 3) Drain the brake fluid from master cylinder.
- 4) Refill the reservoir tank with recommended brake fluid.

#### **Recommended brake fluid:**

**Refer to "RM" section. <Ref. to RM-3, FLUID, RECOMMENDED MATERIALS, Recommended Materials.>**

#### NOTE:

- Avoid mixing different brands of brake fluid to prevent degrading the quality of fluid.
- Be careful not to allow dirt or dust to get into the reservoir tank.

Bleeding sequence (1)→(2)→(3)→(4)

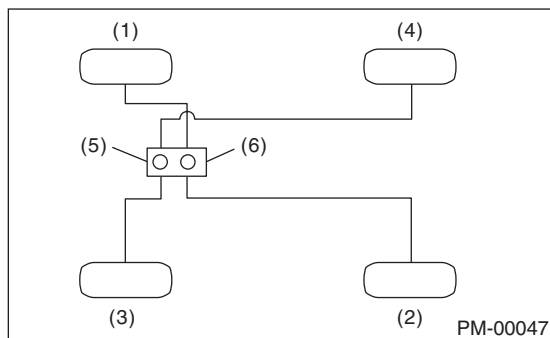

- (1) Front RH
- (2) Rear LH
- (3) Front LH
- (4) Rear RH
- (5) Secondary
- (6) Primary

- 5) Install one end of a vinyl tube onto the air bleeder and insert the other end of the tube into a container to collect the brake fluid.

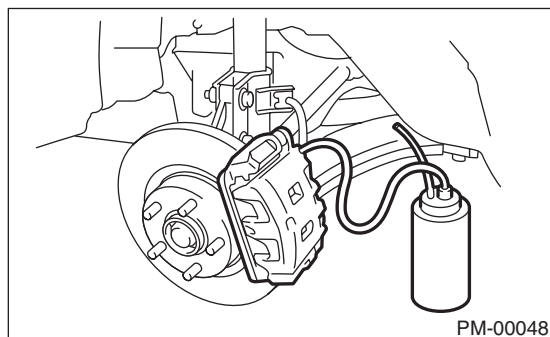

#### NOTE:

- Cover the bleeder with cloth, when loosening it, to prevent brake fluid from being splashed over surrounding parts.
  - During the bleeding operation, keep the brake reservoir tank filled with brake fluid to eliminate entry of air.
  - Operate the brake pedal slowly.
  - For convenience and safety, two people should do the work.
  - The amount of brake fluid required is approx. 500 m<sup>l</sup> (16.9 US fl oz, 17.6 Imp fl oz) for total brake system.
- 6) Instruct your co-worker to depress the brake pedal slowly two or three times and then hold it depressed.
  - 7) Loosen the bleeder screw approximately 1/4 turn until a small amount of brake fluid drains into the container, and then quickly tighten the screw.
  - 8) Repeat steps 6) and 7) until there are no air bubbles in drained brake fluid and new fluid flows through vinyl tube.

#### NOTE:

Add brake fluid as necessary while performing the air bleed operation, in order to prevent the tank from running short of brake fluid.

- 9) After completing the bleeding operation, hold the brake pedal depressed and tighten the screw and install bleeder cap.

#### **Tightening torque:**

**8 N·m (0.8 kgf-m, 5.8 ft-lb)**

- 10) Bleed air from each wheel cylinder by following steps from 5) to 9).
- 11) Depress the brake pedal with a force of approx. 294 N (30 kgf, 66 lb) and hold it there for approx. 20 seconds. At this time check the pedal to see if it makes any unusual movement. Visually inspect the bleeder screws and brake pipe joints to confirm there is no fluid leakage.
- 12) Install the wheels, and drive the vehicle for a short distance between 2 to 3 km (1 to 2 miles) to confirm brakes are operating properly.