

18. Disc Brake Pad and Disc

A: INSPECTION

- 1) Jack-up the vehicle and support with rigid racks. Then remove the wheels.
- 2) Visually check the pad thickness through inspection hole of disc brake assembly. Replace the pad if necessary.

NOTE:

When replacing a pad, always replace the pads for both the left and right wheels at the same time. Also replace the pad clips if they are twisted or worn.

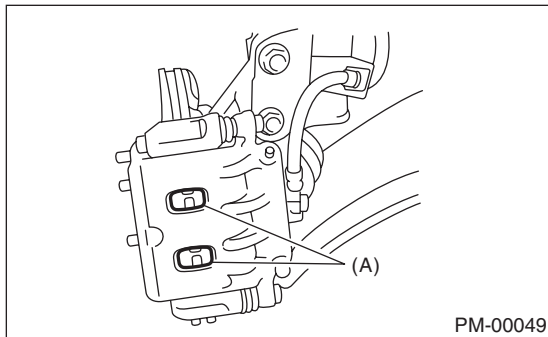

(A) Inspection hole

• Front

Pad thickness		mm (in)
Standard	16-inch	11 (0.43)
	17-inch	11 (0.43)
Wear limit	16-inch	1.5 (0.059)
	17-inch	1.5 (0.059)

• Rear

Pad thickness		mm (in)
Standard	Solid disc type	9 (0.35)
	Ventilated disc type	9 (0.35)
Wear limit	Solid disc type	1.5 (0.059)
	Ventilated disc type	1.5 (0.059)

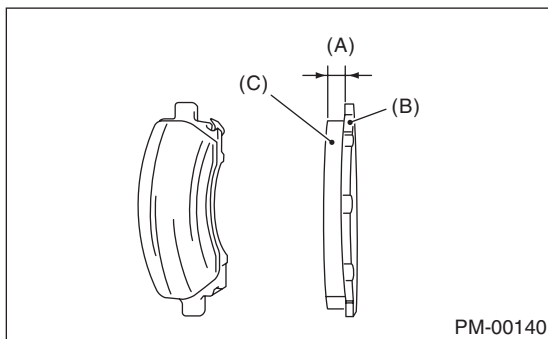

- (A) Pad thickness
- (B) Back metal
- (C) Lining

- 3) Check the disc rotor, and correct or replace if it is damaged or worn.

• Front

Disc rotor thickness		mm (in)
Standard	16-inch	24 (0.94)
	17-inch	30 (1.18)
Wear limit	16-inch	22 (0.87)
	17-inch	28 (1.10)

• Rear

Disc rotor thickness		mm (in)
Standard	Solid disc type	10 (0.39)
	Ventilated disc type	18 (0.71)
Wear limit	Solid disc type	8.5 (0.34)
	Ventilated disc type	16 (0.63)

- 4) Remove the caliper body. <Ref. to BR-17, Front Disc Brake Assembly.> <Ref. to BR-24, Rear Disc Brake Assembly.>

- 5) Tighten the wheel nuts to secure disk rotor.

- 6) Set a dial gauge at a point less than 10 mm (0.39 in) from outer periphery of the rotor, and then measure the disk rotor runout.

Disc rotor runout limit:

Front: 0.05 mm (0.002 in)

Rear: 0.05 mm (0.002 in)

