

6. Radiator

A: REMOVAL

- 1) Set the vehicle on a lift.
- 2) Disconnect the ground cable from battery.

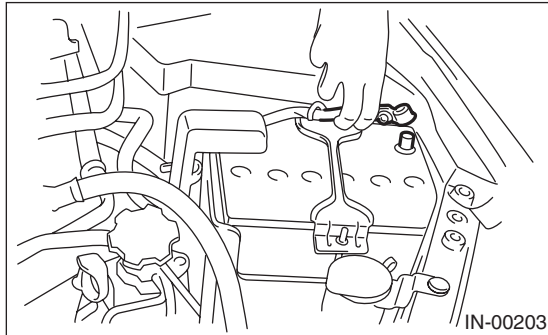

- 3) Lift-up the vehicle.
- 4) Remove the under cover.
- 5) Drain engine coolant completely.
<Ref. to CO(H4SO)-12, DRAINING OF ENGINE COOLANT, REPLACEMENT, Engine Coolant.>
- 6) Remove the radiator under cover.
- 7) Disconnect the radiator main fan motor connector (A) and sub fan motor connector (B).

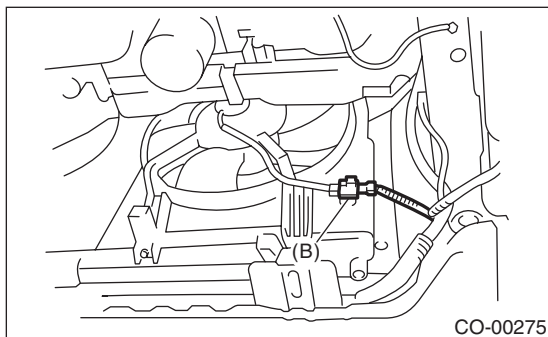
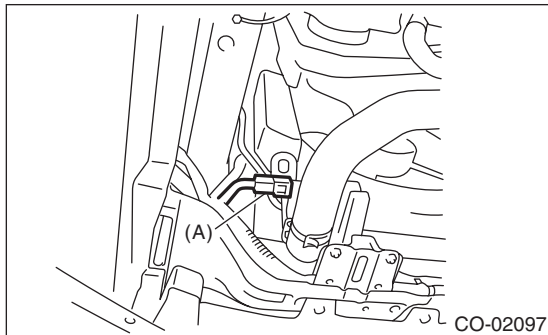

- 8) Disconnect the radiator outlet hose from thermostat cover.

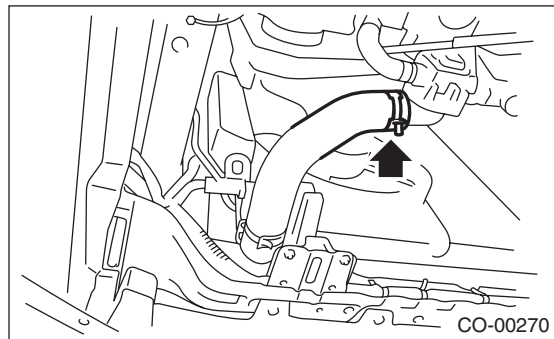

- 9) Disconnect the ATF cooler hoses from ATF pipes. (AT model)
Plug the ATF pipe to prevent ATF from leaking.

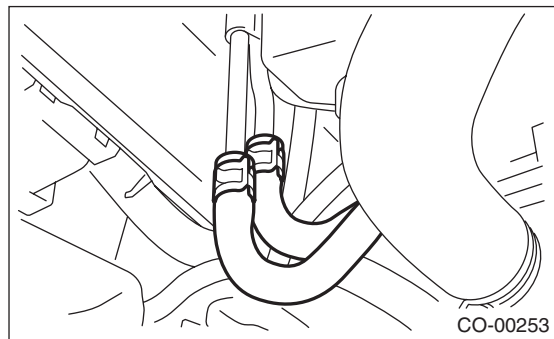

- 10) Lower the vehicle.
- 11) Disconnect the over flow hose.
- 12) Remove the reservoir tank. <Ref. to CO(H4SO)-27, REMOVAL, Reservoir Tank.>
- 13) Remove the hood stay holder.

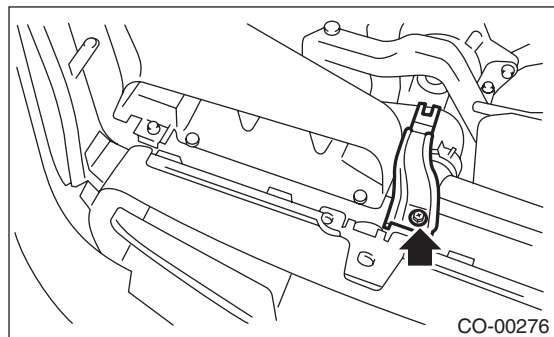

- 14) Remove the air intake duct. <Ref. to IN(H4SO)-8, REMOVAL, Air Intake Duct.>

Radiator

COOLING

- 15) Disconnect the radiator inlet hoses from the engine.

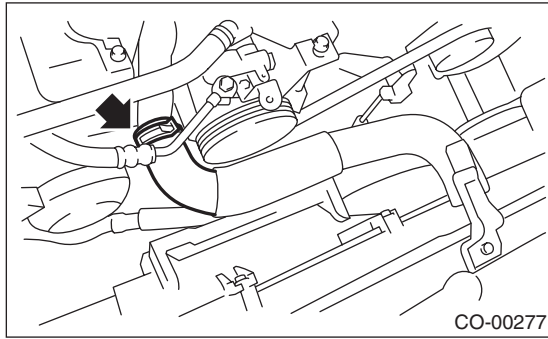

- 16) Remove the radiator upper brackets.

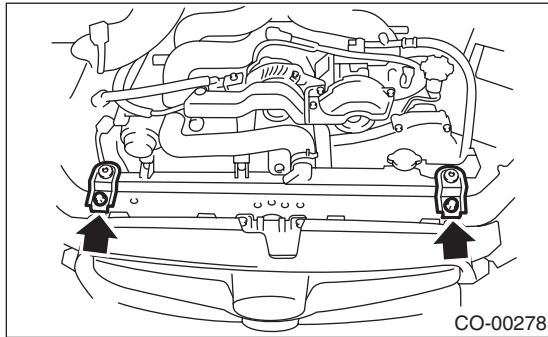

- 17) Lift the radiator up and away from vehicle.

B: INSTALLATION

- 1) Attach the radiator lower cushion to the hole on the radiator lower bracket.

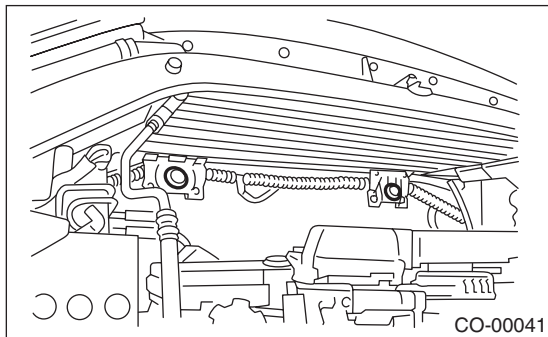

- 2) Install the radiator to vehicle.

NOTE:

Make pins on the lower side of radiator be fitted into the radiator lower cushions on body side.

- 3) Install the radiator upper brackets and tighten the bolts.

Tightening torque:

12 N·m (1.2 kgf·m, 8.9 ft·lb)

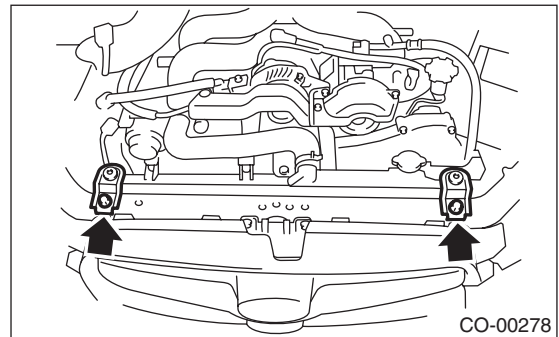

- 4) Connect the radiator inlet hose.

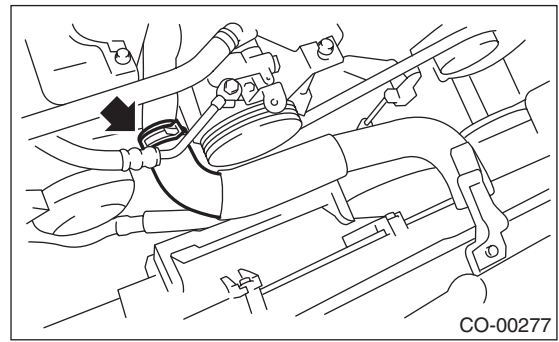

- 5) Install the air intake duct. <Ref. to IN(H4SO)-8, INSTALLATION, Air Intake Duct.>

- 6) Install the hood stay holder.

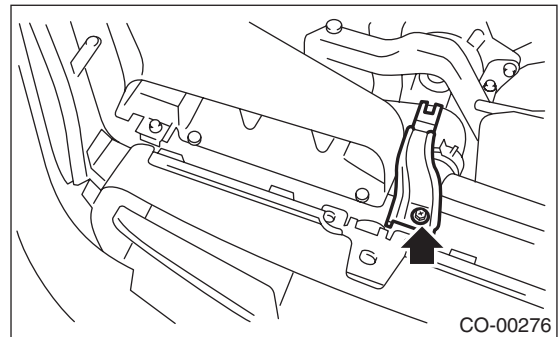

- 7) Install the reservoir tank. <Ref. to CO(H4SO)-27, INSTALLATION, Reservoir Tank.>

- 8) Connect the over flow hose.

- 9) Lift-up the vehicle.

10) Connect the ATF cooler hoses. (AT model)

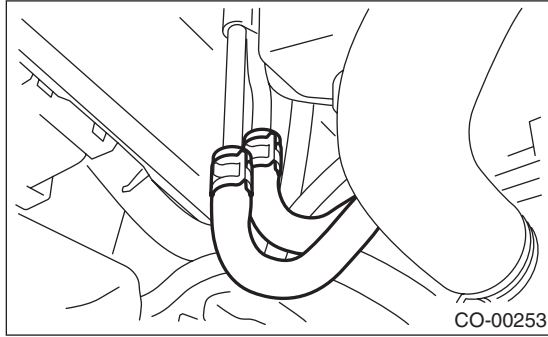

11) Connect the radiator outlet hose.

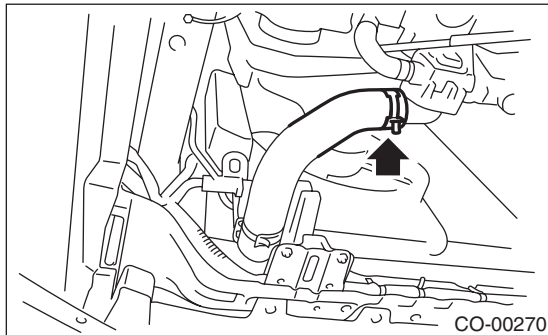

12) Connect the radiator main fan motor connector (A) and sub fan motor connector (B).

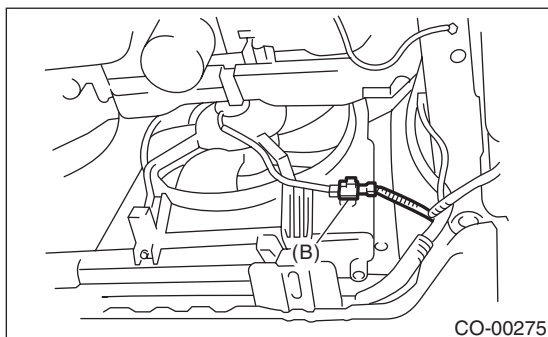
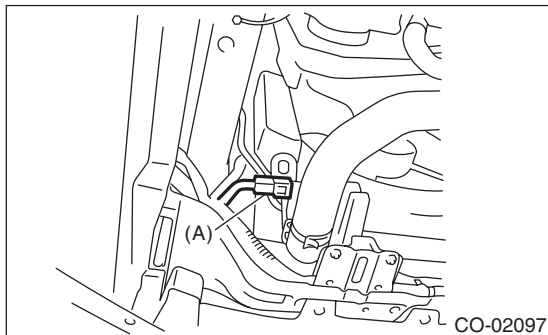

13) Install the radiator under cover.

14) Install the under cover.

15) Lower the vehicle.

16) Connect the battery ground cable to the battery.

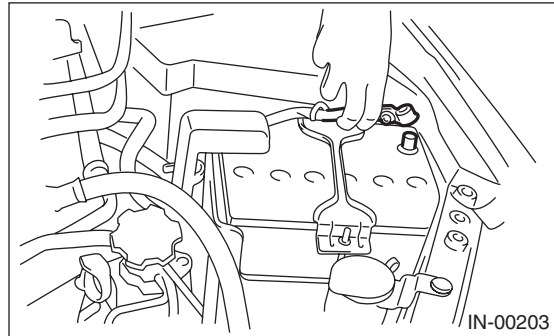

17) Fill engine coolant. <Ref. to CO(H4SO)-12, FILLING OF ENGINE COOLANT, REPLACEMENT, Engine Coolant.>

18) Check the ATF level. <Ref. to 4AT-26, INSPECTION, Automatic Transmission Fluid.>

C: INSPECTION

1) Remove the radiator cap, fill the radiator with engine coolant, and then install the tester to the installation position of cap.

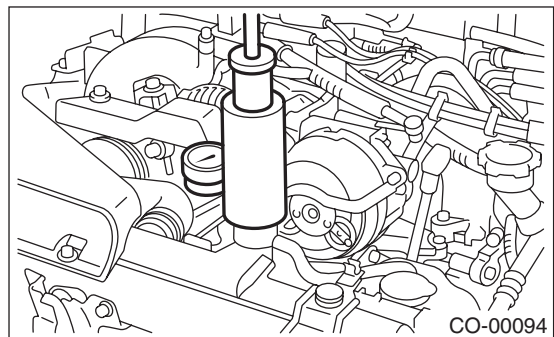

2) In the following cases, apply a pressure of 157 kPa (1.6 kg/cm², 23 psi) to the radiator.

- There is coolant leaking from the radiator or its vicinity.
- There is coolant leaking from the hoses or connections.

CAUTION:

- Engine should be turned off.
- Wipe engine coolant from check points in advance.
- Be careful of engine coolant from spurting out when removing the tester.
- Be careful not to deform the filler neck of radiator when installing and removing the tester.