

# Purge Control Solenoid Valve

EMISSION CONTROL (AUX. EMISSION CONTROL DEVICES)

## 5. Purge Control Solenoid Valve

### A: REMOVAL

1) Disconnect the ground cable from the battery.

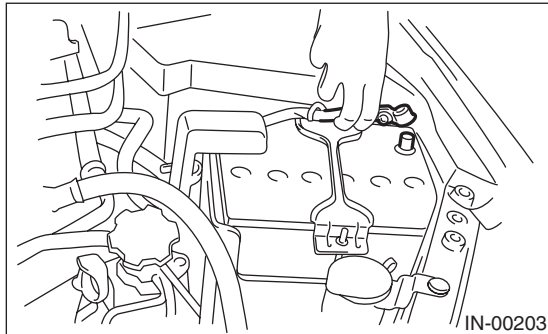

2) Disconnect the connector and evaporation hose of the purge control solenoid valve, then remove the purge control solenoid valve.

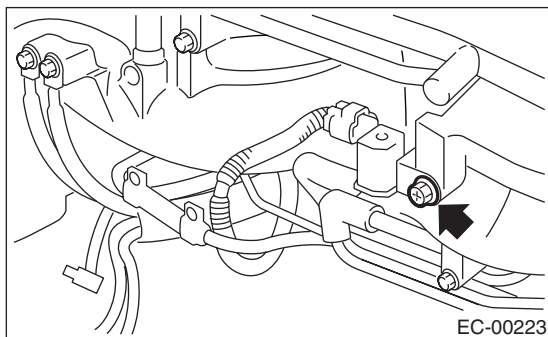

### B: INSTALLATION

Install in the reverse order of removal.

**Tightening torque (Purge control solenoid valve attachment bolt):**

**19 N·m (1.9 kgf·m, 14 ft·lb)**

NOTE:

Connect the evaporation hose as shown in the figure.

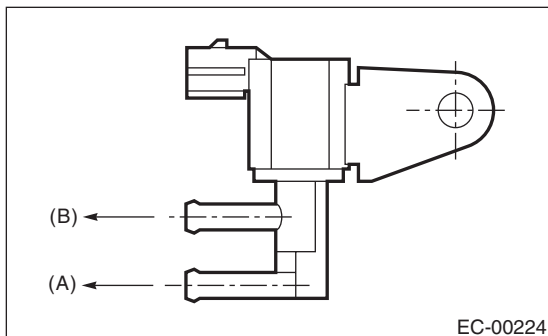

- (A) To fuel pipe (intake manifold)
- (B) To fuel pipe (evaporation line)

### C: INSPECTION

Make sure the hoses are not cracked or loose.