

3. Ignition Coil and Ignitor Assembly

A: REMOVAL

1) Disconnect the ground cable from the battery.

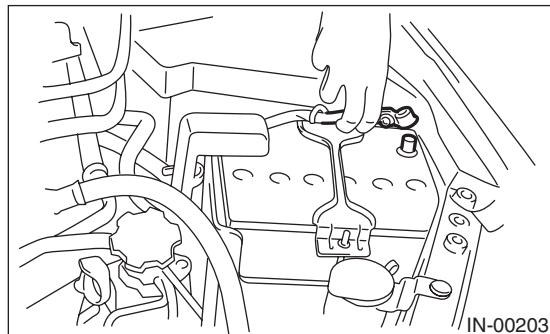

2) Disconnect the spark plug cords from the ignition coil and ignitor assembly.

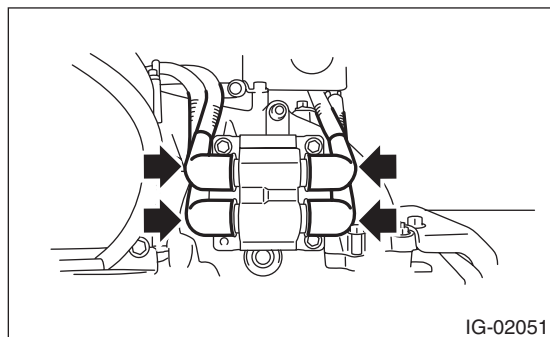

3) Disconnect the connector from the ignition coil and ignitor assembly.

4) Remove the bolt which secures the ignition coil and ignitor assembly to the intake manifold.

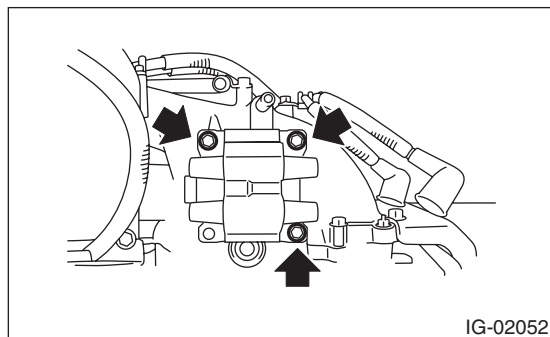

B: INSTALLATION

Install in the reverse order of removal.

Tightening torque:

8 N·m (0.82 kgf·m, 5.9 ft·lb)

CAUTION:

Connect the spark plug cords to the correct positions. Failure to do so will damage the unit.

C: INSPECTION

Check the following items using a tester. Replace if defective.

Secondary coil resistance

CAUTION:

- If the resistance is extremely low, it indicates the presence of a short-circuit.
- Ignitor is integrated with the coil. Therefore the resistance of primary side coil cannot be measured.

Specified resistance:

[Secondary side]

Between (A) and (B)

11.2 kΩ±15%

Between (C) and (D)

11.2 kΩ±15%

