

17.Crank Sprocket

A: REMOVAL

- 1) Remove the V-belts. <Ref. to ME(H4SO)-36, REMOVAL, V-belt.>
- 2) Remove the crank pulley. <Ref. to ME(H4SO)-38, REMOVAL, Crank Pulley.>
- 3) Remove the timing belt cover. <Ref. to ME(H4SO)-39, REMOVAL, Timing Belt Cover.>
- 4) Remove the timing belt. <Ref. to ME(H4SO)-40, REMOVAL, Timing Belt.>
- 5) Remove the crank sprocket.

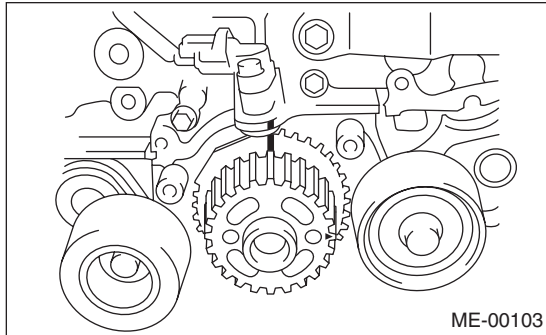

B: INSTALLATION

- 1) Install the crank sprocket.

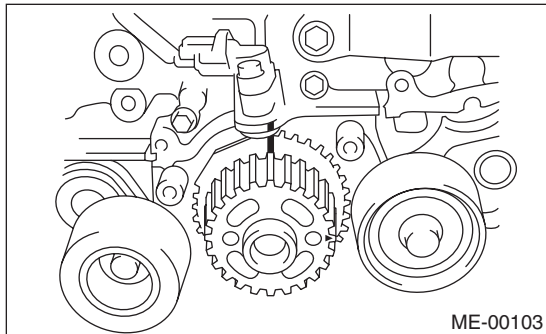

- 2) Install the timing belt. <Ref. to ME(H4SO)-41, INSTALLATION, Timing Belt.>
- 3) Install the timing belt cover. <Ref. to ME(H4SO)-39, INSTALLATION, Timing Belt Cover.>
- 4) Install the crank pulley. <Ref. to ME(H4SO)-38, INSTALLATION, Crank Pulley.>
- 5) Install the V-belts. <Ref. to ME(H4SO)-36, INSTALLATION, V-belt.>

C: INSPECTION

- 1) Check the crank sprocket teeth for abnormal wear and scratches.
- 2) Make sure there is no free play between crank sprocket and key.
- 3) Check the crank sprocket protrusion used for sensor for damage and contamination of foreign matter.